

THE HARDY CATALYTIC

**INSTALLATION AND
OPERATING INSTRUCTIONS**

for

**THE HARDY
OUTSIDE WOOD
BURNING FURNACE**

Model - H8/3

HARDY MANUFACTURING CO., INC.
ROUTE 4, BOX 156
PHILADELPHIA, MISSISSIPPI 39350
PHONE: (601) 656-5866 or (601) 656-6948
FAX: (601) 656-4559

THE HARDY CATALYTIC

OPERATING INSTRUCTIONS
AND INSTALLATION

FOR
THE HARDY
OUTSIDE WOOD
BURNING FURNACE

Model - H83

HARDY MANUFACTURING CO., INC.
ROUTE 4, BOX 158
PHILADELPHIA, MISSISSIPPI 39350
PHONE: (601) 856-8888 or (801) 856-6948
FAX: (601) 856-1559

INTRODUCTION

Thank you for purchasing the CATALYTIC all stainless steel Hardy Outside Wood Burning Furnace. It represents the result of many years of Hardy experience and the input of Hardy customers in the production of a top quality furnace. With the purchase of this Hardy Furnace, you can now appreciate the high degree of craftsmanship and reliability that have made The Hardy the leader in the Outside Woodburning Furnace field. This manual will provide you with a good basic understanding of the installation and operation of this furnace.

THIS MANUAL INCLUDES IMPORTANT SAFETY INFORMATION.

Your new furnace should have the following:

- (1) Owners Manual complete with Installation and Hook-Up Instructions
- (2) Warranty & Return Warranty Card
- (3) A tube of silicon (located in the firebox for shipping)
- (4) One section of smoke stack and condenser tank stack both with trim (located in firebox for shipping)
- (5) Three cast iron grates (located in firebox)
- (6) Two I-beams (located in firebox)
- (7) Shovel (located in the firebox for shipping)
- (8) Stainless steel panel and insulation that will be located between the firebox door & ash door after installation of the furnace.
- (9) 3 Catalytic combustor housing, with catalytic combustors
- (10) Flame buster / secondary air tubes (located in firebox for shipping)
- (11) Cleaning kit including : gloves, blow dryer, wirebrush, and creosote scraper

Should your furnace not have any of these items or if you have any questions regarding the operation or maintenance of your furnace, please consult your local Hardy Dealer.

Again, thank you for purchasing a Hardy Furnace.

Sincerely,

Frank L. Moore
President

Hardy Manufacturing Company Incorporated

(Model H8)

Please fill in the following information

Hardy Model _____

Serial Number _____

Date of Purchase _____

Date of Installation _____

Dealer Purchased from _____

Dealer Address _____

Dealer Phone Number _____

Please keep this manual with all other important papers. The information in this manual is necessary for the installation, operation and proper use of this unit. If you should ever have a problem or question please refer to this manual or have it available when you call your Hardy Dealer or Hardy Manufacturing Company Incorporated.

HARDY MANUFACTURING CO., INC.
ROUTE 4, BOX 156
PHILADELPHIA, MISSISSIPPI 39350
PHONE: (601) 656-5866 or (601) 656-6948
FAX: (601) 656-4559

(Model H8)

SAFETY PRECAUTIONS WARNING

Do not operate this equipment for other than its intended purpose nor other than in accordance with the instructions contained in this manual and all other instructions accompanying the unit.

For units covered by this instruction book, it is important to observe safety precautions to protect yourself from possible injury. Among the many considerations, you are advised to:

- * Observe all safety stickers on the unit
- * This unit must be wired by a qualified electrician in accordance with the National Electrical Code.
- * Never use any type of petroleum product, petroleum based product, charcoal starter, lighter fluid, or any other flammable accelerant to start your unit.
- * Always open the ash door (bottom) before you open the firebox door.
- * Never leave the doors open, always latch the doors securely.
- * Always use proper care when installing, operating and maintaining the unit.
- * Do not modify the unit.
- * Do not substitute repairs which can be provided by your dealer, distributor, or Manufacturing Company.

Failure to heed this warning or any additional warnings on the unit may result in an accident causing personal injury.

THE HARDY OUTSIDE WOODBURNING FURNACE

How does The Hardy CATALYTIC heat my home?

The Hardy Catalytic Wood Furnace is designed to burn wood clean and efficiently. An aquastat on the back of the furnace controls the automatic damper and blower for primary and secondary combustion. The heat is transferred to water that surrounds the firebox and the secondary burn chamber. 16 gauge 304 stainless steel is used in the firebox and secondary burn chamber for its superb heat exchange characteristics. Excellent heat exchange is necessary to prevent useful heat from escaping up the smoke stack. The furnace is non-pressurized for safety considerations. The pump that comes standard with the furnace circulates hot water underground to your existing home heating system. If you have a forced air system, the water is circulated through a hot water coil and your existing central unit will force air across the coil and through your duct system. If you have hot water baseboard, the water is circulated through existing baseboard or any existing hydronic heating system that operates at 180° F or less.

How does THE HARDY CATALYTIC heat water for household use?

A plate heat exchanger is installed in the hot water circulator line. When you open a hot water faucet inside your home, the cold water passes through the other side of the heat exchanger and the water going into your hot water heater is preheated. The only energy required is for maintaining the hot water temperature. The plate heat exchangers can be used for pools, dairies and other domestic hot water needs.

How do the Thermostat and Aquastat Controls work?

The only visible addition to the heating system inside your home is the thermostat which is located near the existing thermostat. Two thermostats are needed so that if the outside wood furnace is not in operation, your existing unit will automatically take over to maintain your household temperature. The wall thermostat which regulates the home heat from the outside furnace performs two functions; when it senses your need for heat according to your temperature setting, it turns the water pump on to circulate the hot water through the hot water coil and also turns the blower on inside your central unit to force air across the hot coil. This forces hot air into your central duct system. The outside furnace has a hot water aquastat which senses the water temperature of the unit. If the water is not as hot as the aquastat setting, then the combustion air intake for primary and secondary combustion is automatically opened and remains open until such temperature is attained.

Where should an Outside Wood Burning Furnace be located?

The outside unit should be located at least 10 feet from your home so that all fire danger is removed from your home. The unit may be installed as much as 100 ft. away and still heat your house. If the unit is located more than 100 feet away, you may experience unnecessary heat loss in the buried water pipes. Locate the outside wood furnace where it will be convenient for refueling and wood storage. All water and power lines are installed underground between the house and the outside wood furnace.

TABLE OF CONTENTS

SECTION I: General Information

| | |
|--|---|
| 1-1 Specifications | 1 |
| 1-2 Furnace Component Parts (Model H8) | 2 |

SECTION II: Installation Of Furnace

| | |
|---|-------|
| 2-1 Location of Furnace | 3-4 |
| 2-2 Hull Removal | 5 |
| 2-3 Set-Up of Grates | 6 |
| 2-4 Set-Up of Catalytic Combustors | 7 |
| 2-5 Location of Plumbing and Electrical Lines | 8 |
| 2-6 Connection of Power to Furnace | 9 |
| 2-7 Wiring Diagram | 10 |
| 2-8 Plumbing Instructions | 11 |
| 2-9 Filling the Furnace with Water | 12-13 |

SECTION III: Connection to Central Heating/AC System

| | |
|---|-------|
| 3-1 Connection to Central Unit with existing Blower Relay | 14-16 |
| 3-2 Connection to Central Unit without existing Blower Relay | 17-19 |
| 3-3 Location of Heating Coil | 20-21 |

SECTION IV: Connection to Hydronic Heating Systems (Baseboard)

| | |
|--|-------|
| 4-1 Connection to Hydronic System with new 24 Volt Transformer | 22-23 |
| 4-2 Connection to Hydronic System with existing 24 Volt Transformer | 24-25 |
| 4-3 Typical Diagram for Plumbing Hydronic System | 26 |

SECTION V: Plumbing for Domestic Water

| | |
|--|----|
| 5-1 Plate Heat Exchanger for Domestic Hot Water located at Hot Water Heater | 27 |
| 5-2 Automatic Water Fill | 28 |

SECTION VI: Furnace Operation

6-1 Firing the Furnace 29
6-2 Water Temperature 29
6-3 Wood Usage 29
6-4 Moisture in the Firebox 29
6-5 Improper Burning 30
6-6 Ash Removal 31
6-7 Operating Instructions Summary 31

SECTION VII: SERVICE INFORMATION

7-1 Water Circulation System 32
7-2 Temperature Control System 33-34
7-3 Preseason Heater Maintenance 35
7-4 Trouble Shooting Guide 36-38

SECTION VIII: Repair Parts 39

SECTION I

GENERAL INFORMATION

1 - 1 Specifications

Type of fuel - Wood

For outdoor use only

Electrical Rating 115 VAC/ 60 HZ / 1P
MFS-15 AMP, MCA-15 AMP

Clearance to Combustibles

Top, Rear, Sides - 18"

Chimney Connector - 18"

Front - 48"

Flooring - Non Combustible

Water Capacity

H8 - Holds 85 Gallons of Water

FURNACE DIMENSIONS

| <u>Description</u> | <u>Wide</u> | <u>Depth</u> | <u>Height</u> | <u>WEIGHT</u> |
|--------------------|-------------|--------------|---------------|---------------|
| H8 - 150,000 BTU | 30" | 52 1/2" | 59 1/2" | 750 lbs. |

FIREBOX SIZES

| <u>Description</u> | <u>Wide</u> | <u>Depth</u> | <u>Height</u> |
|--------------------|-------------|--------------|------------------------|
| H8 - 150,000 BTU | 24" | 32" | 36" plus 8" for Grates |

Section I 1 - 2 Furnace Component Parts (Model H8)

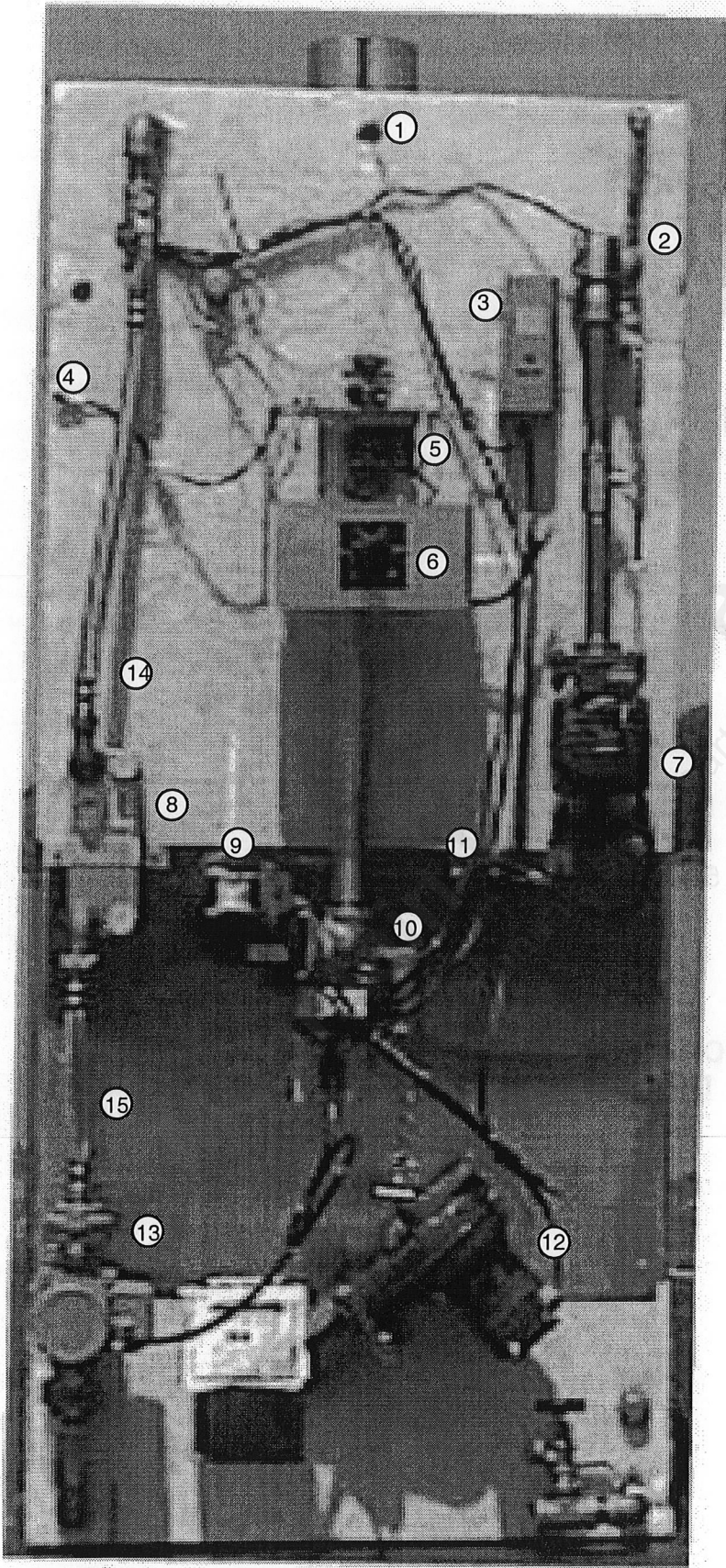

| LEGEND | PART # | DESCRIPTION |
|--------|----------|-------------------------|
| 1 | H1100.27 | LOW WATER SWITCH |
| 2 | H1100.00 | ELECTRIC WATER SOLENOID |
| 3 | H2000.16 | DAYTON THERMOSTAT |
| 4 | H1100.30 | LOW WATER LIGHT |
| 5 | H2620.00 | GEAR MOTOR |
| 6 | H2617.00 | TEMPERATURE CONTROLLER |
| 7 | H501.00 | TACO 009 PUMP |
| 8 | H300.02 | PLATE HEAT EXCHANGER |
| 9 | H2002.68 | SECONDARY AIR BLOWER |
| 10 | H2001.00 | DAMPER SOLENOID |
| 11 | H2000.52 | RELAY |
| 12 | H2002.16 | 100 CFM BLOWER/LID |
| 13 | H507.00 | TACO 007 PUMP |
| 14 | H700.12 | 3/4" X 18" FLEX LINE |
| 15 | H700.05 | 3/4" X 10" FLEX LINE |

SECTION II

INSTALLATION OF FURNACE

Section II 2 - 1 Location of Furnace

The Hardy furnace is designed to set outside the building to be heated. The unit must be located a minimum of 10 feet from the building. The unit should be installed upon a concrete pad. There are two typical options that we recommend.

Option 1 has the unit installed on a concrete pad with the rear of the water tank flush with the end of the pad. We recommend the pad to be 48" wide and 48" long minimum. If you add extra length it will allow ample concrete in front of the Furnace for loading wood and removing ashes. The space between the rear of the unit and the outside cover will allow a 4 inch water tight pipe or other means to insulate the plumbing and electrical lines to run directly into the ground. The outside cover can be removed by lifting it off the water tank on all four corners. This will allow you easy access for the connection of the plumbing and electrical lines.

Please see the illustration below for details.

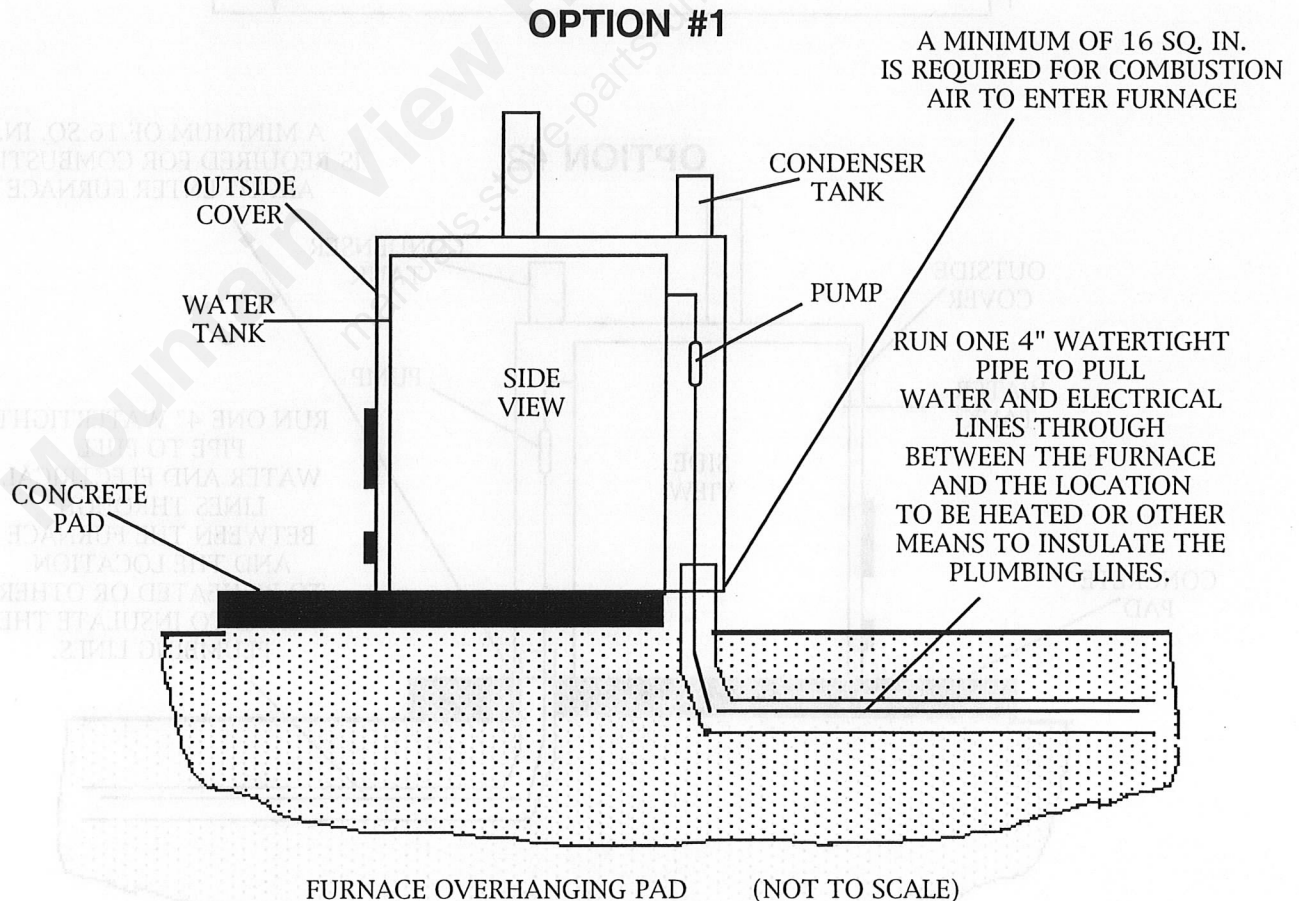

Section II 2 - 1 Location of Furnace (continued)

Option 2 illustrates the unit installed on a concrete slab with a cut out in the slab for the plumbing and electrical connects to run through. We recommend this pad to be 48" wide by 60" long minimum. If you add extra length it will allow ample concrete in front of the Furnace for loading wood and removing ashes. The 4 inch watertight pipe or other means to insulate plumbing that runs underground exits through this cut out to allow connections to the unit. The unit sits on the slab with the rear of the water tank flush or even with the front side of the cutout. The outside cover of the furnace can be removed by lifting it from the water tank on all four corners. This will allow you easy access for the plumbing and electrical connections.

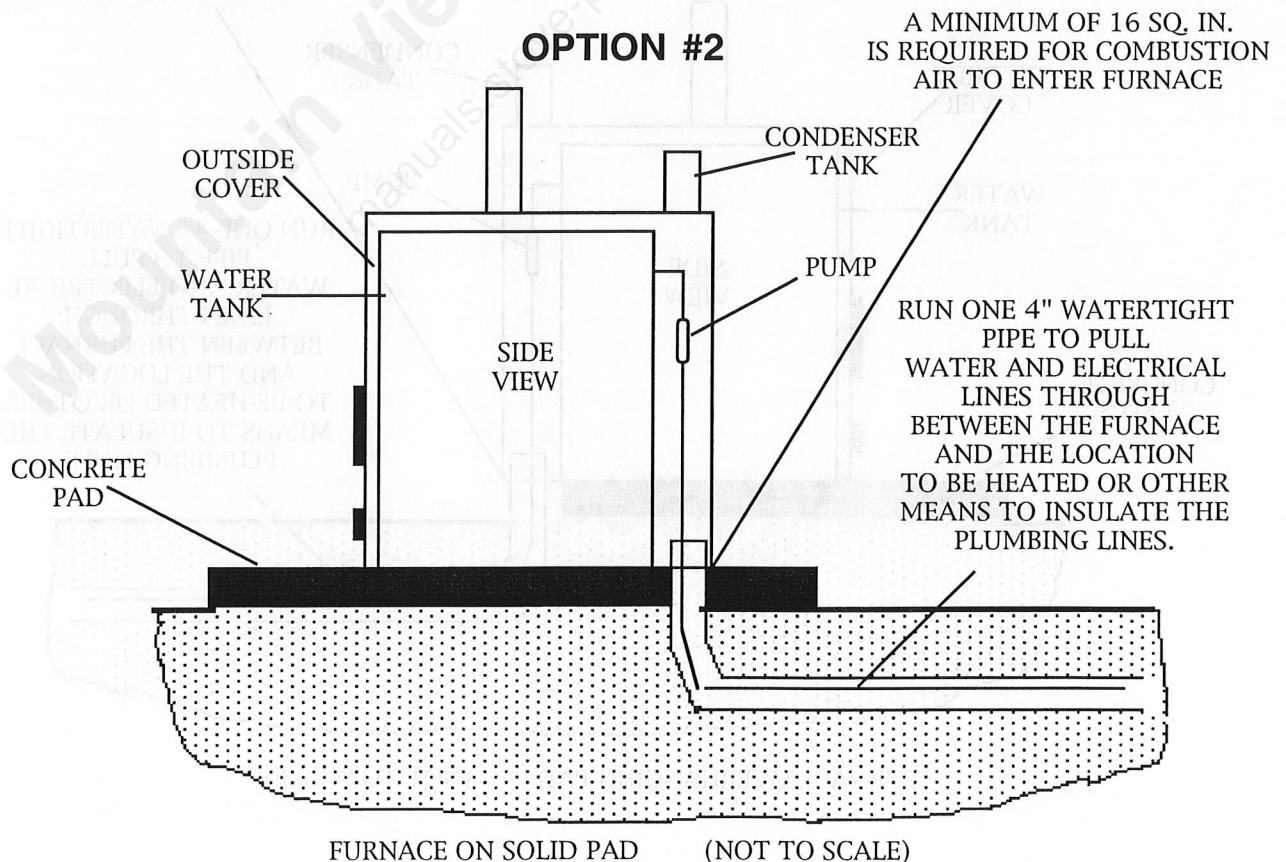
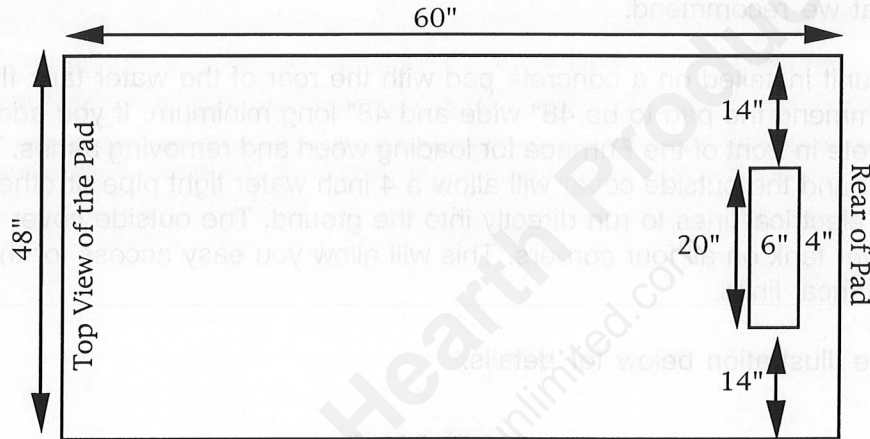

Section II 2 - 2 Hull Removal

After placing your new Hardy Furnace upon the concrete pad, you are ready to continue the installation process. There are two methods to gain access to the rear of the furnace to make plumbing and electrical connections.

The first and easiest method is to remove the screw holding the back door panel in place. The door is easily removed by lifting up on the handle, sliding the door up and taking it out. With the back door removed, using a 5/16" wrench, remove the 8 metal screws that are located below the back door. There are four on each side that hold the panel in place. After the screws are removed, the panel should come out easily and allow access to the bottom of the unit to make plumbing and electrical connections.

The second method is the removal of the entire cover. With the back door and the rectangular piece of stainless and insulation between the fire box and ash door removed, the outside cover can be lifted up and off as seen in the picture. To replace the cover simply repeat these steps in reverse order.



REAR

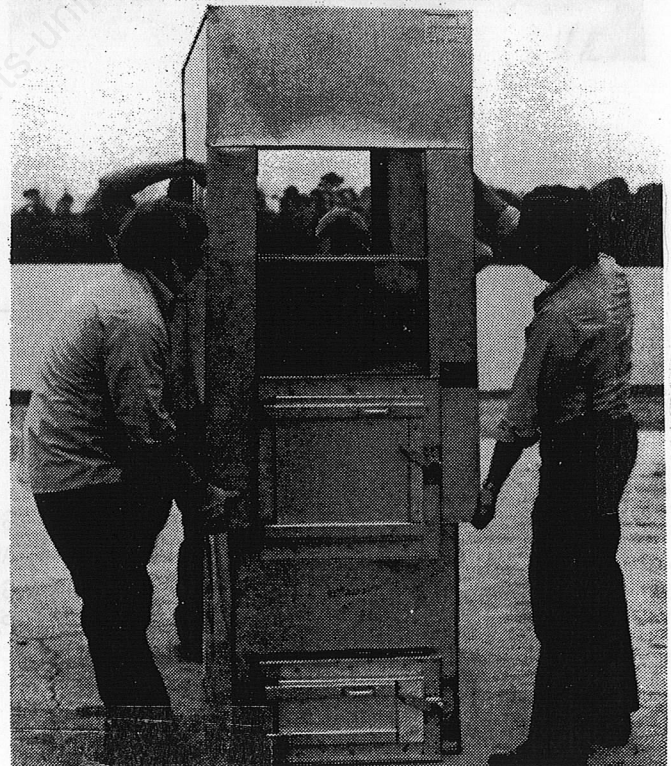

FRONT

Section II 2 - 3 Set-Up of Grates

First open the firebox door and remove everything from inside of the furnace except the two I-beams and three grates. Stand the two I-beams up on end and over against the tabs as shown in the picture below. The grates can now be placed on the I-beams in line and end to end. The picture below shows the proper way for grates to be installed. Also install the side angle smoke passage frames, place the frames on top of the grates and lean to the side, place top spacer bracket into the top of the angle frames. This frame will provide a passage for the smoke to proceed to the catalytic combustors.

These grates are designed to be turned over if they warp.

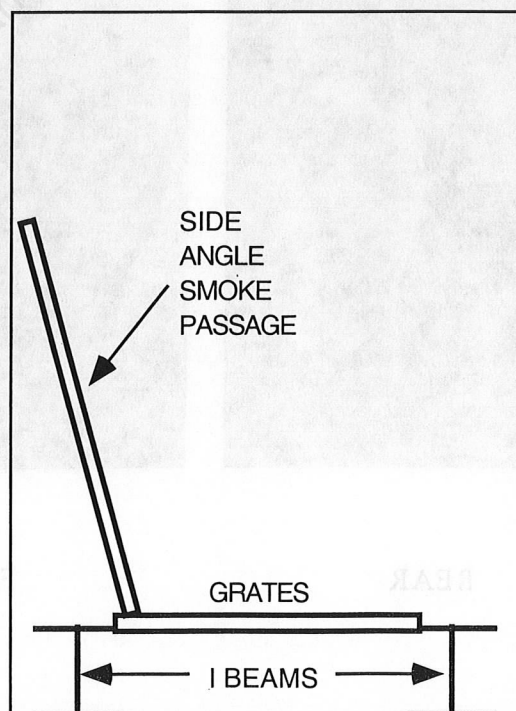
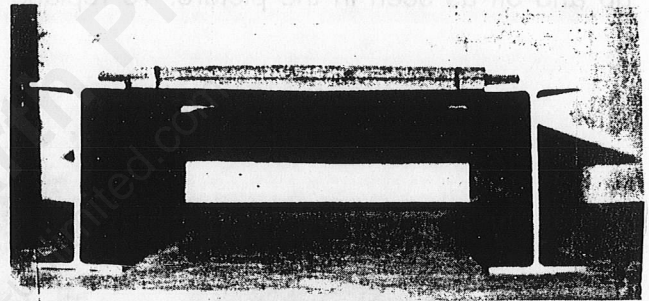
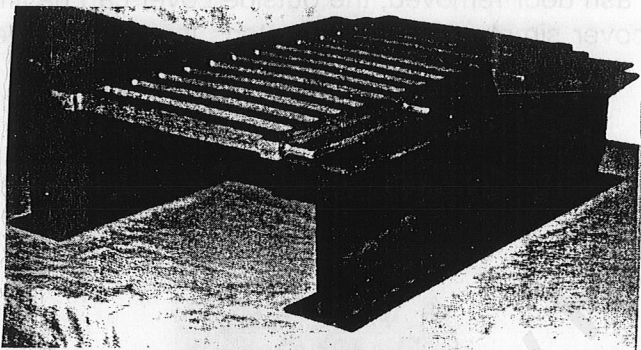

Section II 2 -4 Set-Up of Catalytic Combustors and Controls

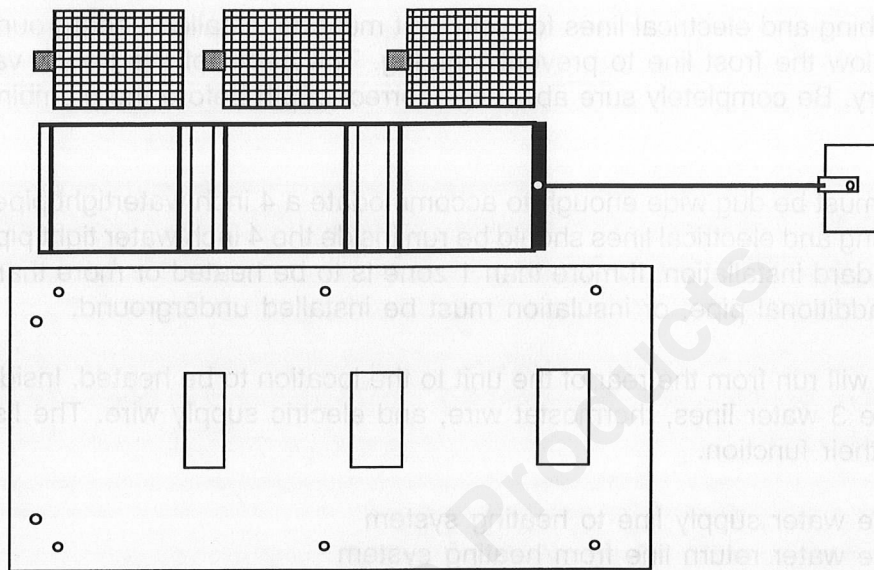

Setup Of Catalytic Combustors:

Inside the furnace you will find a combustor slide tray, and three combustor housing units. Place the combustor slide tray into the upper chamber with the flanged end toward the back of the furnace the flange should be facing up. Inside the upper chamber there is a 1/4" rod bent up on the end. Hook the slide tray onto the bent rod and align the slide tray between the two pins that are in the bottom of the upper chamber. Insert the three combustor housing units into the slide tray, with the 1" x 1" square handle holder toward the front of the furnace. Inside the furnace there is a piece of stainless steel 10 1/2" x 24", this piece is to be placed on top of the combustor housing units to direct the hot gases away from the stack outlet allowing the gases to spread through the recovery chamber before exiting the furnace.

Flame Buster Plate:

Inside the fire box there is a 1" pipe nipple through the back wall of the fire box, this is the secondary air tube. A wing shaped stainless steel flame buster located in the fire box will need to be placed on top of the secondary air tube and connected to the eye bolts in the front of the fire box. This flame buster should be cleaned off regularly by bumping the flame buster with your combustor handle. The flame buster plate can be removed for inspection and thorough cleaning when necessary.

Installation of Temperature Sensors:

There is a temperature sensor probe connected to the temperature controller on the back of the furnace. This probe must be installed into the smoke stack of the furnace. Lift the hull off the furnace, feed the probe through the top insulation beside the condenser tank, run the probe wire above the insulation to the smoke stack where you will find a hole drilled through the collar. There is a short section of smoke stack with a hole drilled that will match the hole in the collar, place this stack into the main furnace stack and align probe holes. Insert the temperature probe into the predrilled holes leaving 1" of the probe outside the stack

Section II 2 - 5 Location of Plumbing and Electrical Lines

The plumbing and electrical lines for your unit must be installed underground. The water lines must be buried below the frost line to prevent freezing. The depth of the trench varies to different regions of the country. Be completely sure about the correct depth before the plumbing lines are installed underground.

A trench must be dug wide enough to accommodate a 4 inch watertight pipe or other insulation means. All plumbing and electrical lines should be run inside the 4 inch water tight pipe or other insulation means for a standard installation. If more than 1 zone is to be heated or more than 1 location is to be heated then an additional pipe, or insulation must be installed underground.

This pipe will run from the rear of the unit to the location to be heated. Inside the 4 inch watertight pipe will be the 3 water lines, thermostat wire, and electric supply wire. The listing below describes each line and their function.

1. One water supply line to heating system
2. One water return line from heating system
(All of these must be at least 3/4" pipe and may require 1" because of longer distances on some hydronic applications)
3. One cold water supply line
4. One hot water supply to hot water heater
5. One 3 conductor thermostat wire
6. One #12/2 W/G UF underground Romex wire

If more than one location is to be heated, a second 4 inch watertight pipe or other insulation means will need to be installed underground for the water lines and thermostat wires of the second location.

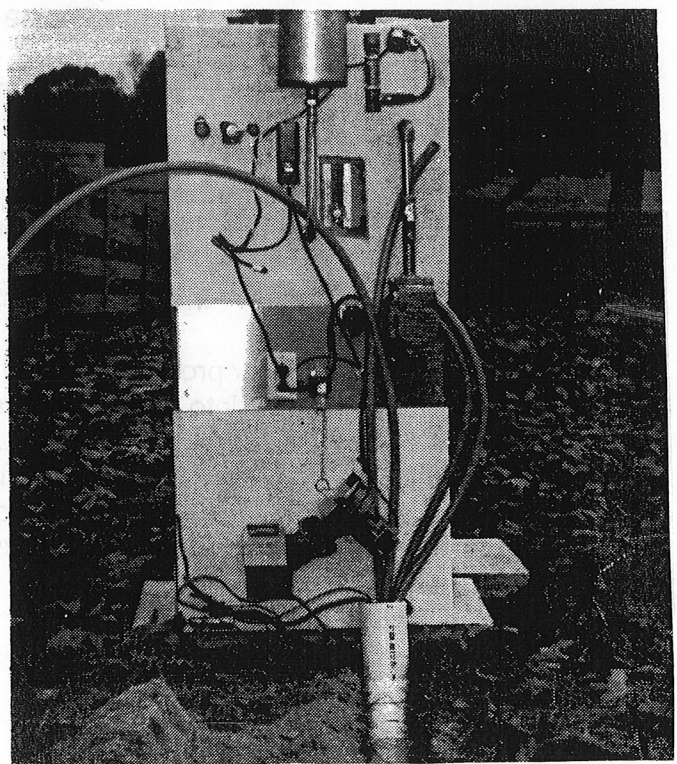

Section II 2 - 6 Connection of Power to Furnace

**This unit must be wired by a qualified electrician
in accordance with the National Electrical Code.**

1. The #12/2 W/G UF wire is run from the electrical system in the house through the 4" watertight pipe or other insulation means to the furnace.
2. This wire will connect to the Ground Fault Circuit Interrupter (GFCI) on the back of the furnace.
3. Install a Romex connector in the bottom of the electrical makeup box, and insert Romex wire through this connector.
4. Connect the black wire to the brass screw on the line side of the GFCI receptacle.
5. Connect the white wire to the silver screw on the line side of the GFCI receptacle.
6. Connect the bare copper wire to the green screw on the GFCI receptacle.
7. After the wiring is complete check the receptacle with a circuit tester to determine if the polarity is correct, and to make sure the ground is connected. Press the test button on the GFCI receptacle the reset button should pop out indicating the interrupter is operating correctly. Push the reset button back in to restore the GFCI receptacle to normal operation. This test should be done monthly to insure safe operation of the furnace.
8. If moisture is allowed into Ground Fault Circuit Interrupter box, it will have a tendency to trip unwarranted. Measures should be taken to keep the box dry.

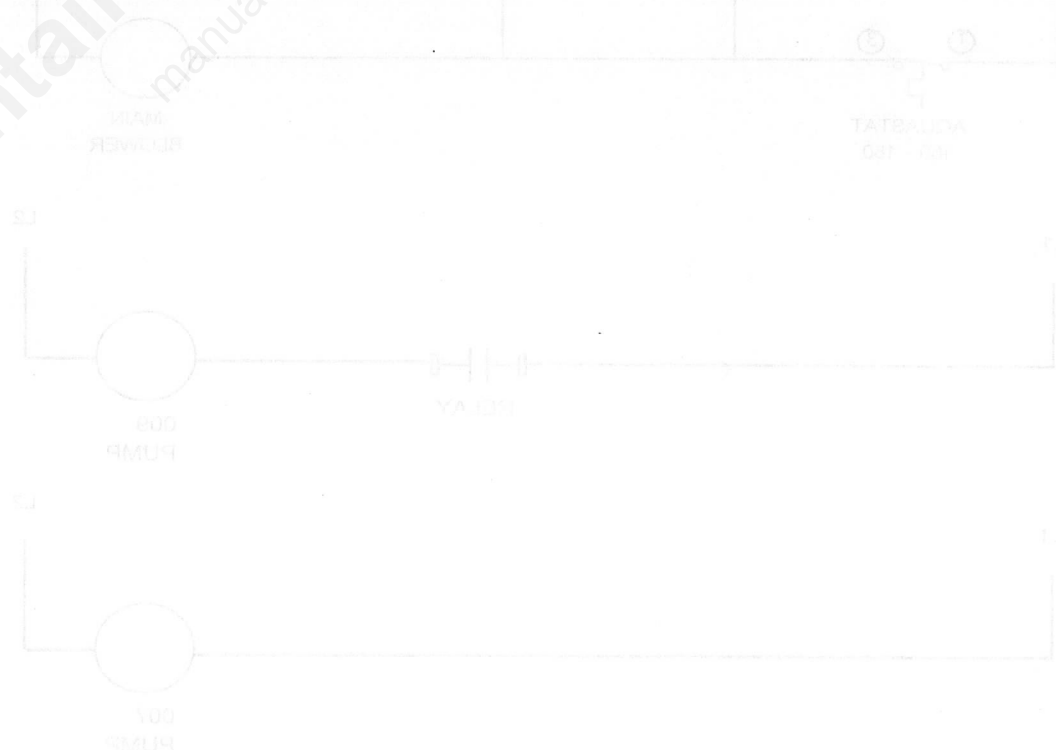

Section II 2 - 7 Wiring Diagrams

This equipment must be installed in accordance with the National Electrical Code.

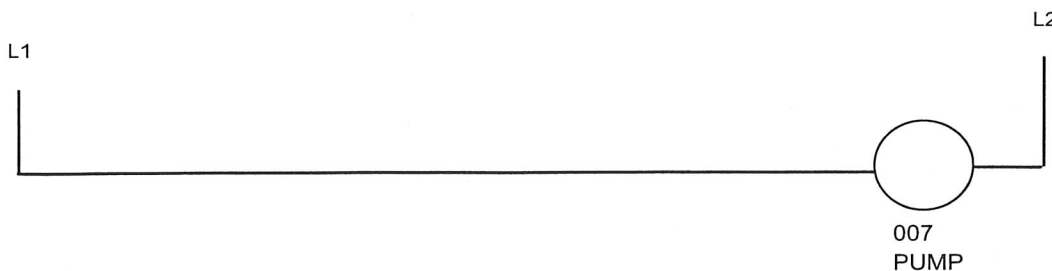
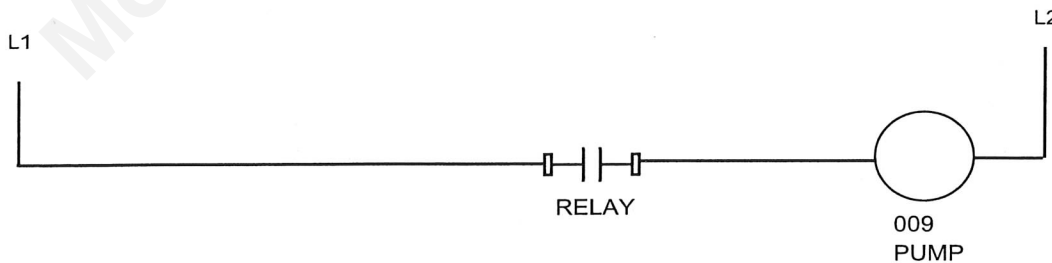
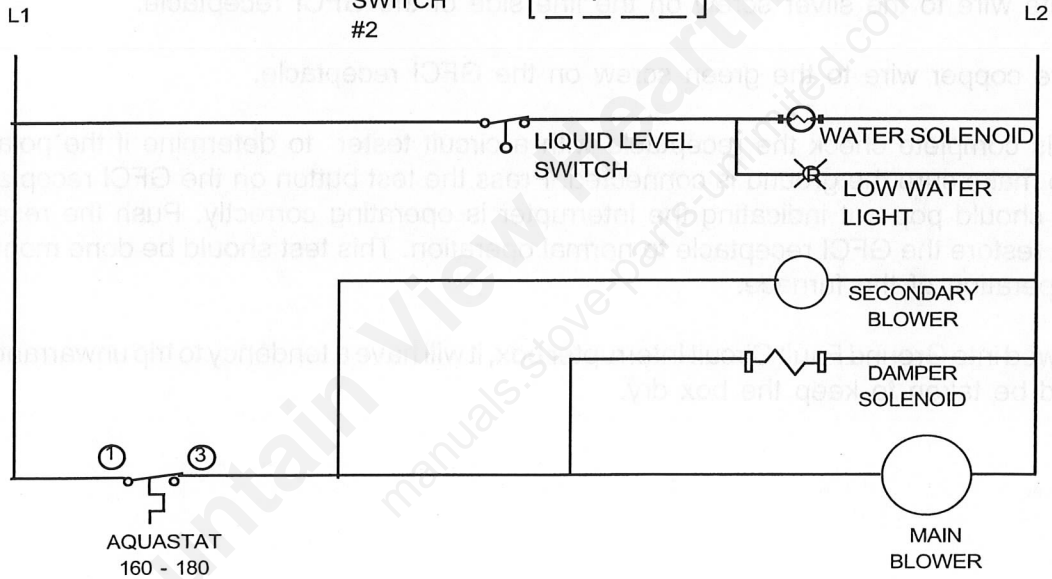
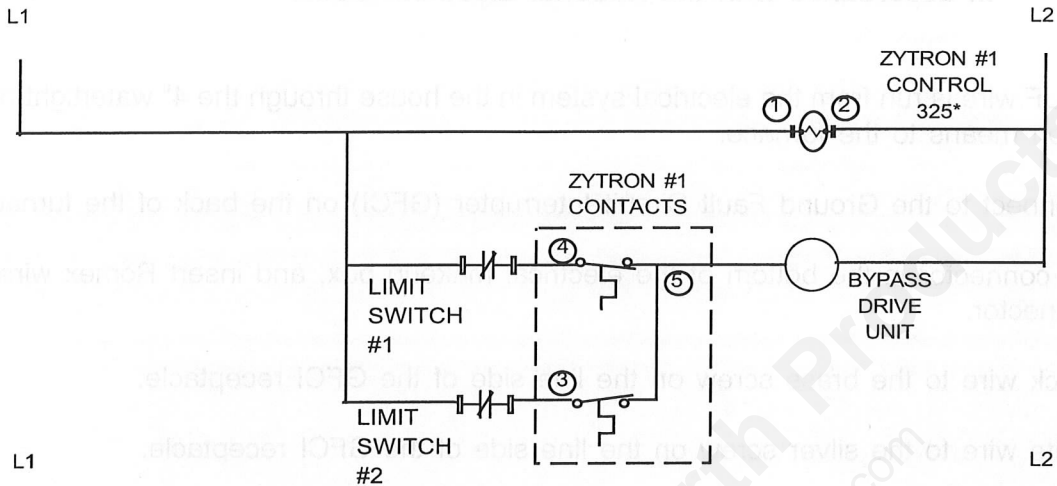

Section II 2 -8 Plumbing Instructions

Connection to Heating System

1. The pipe that will supply the heating system is connected to the under side of the pump. This pump is located on the right hand side of the furnace (noted by #3 in diagram).
2. The pipe that will carry the return water from the heating system is connected to the 3/4" brass tee located at the bottom left hand corner of the furnace (noted by # 4 in diagram).

Water Pipes must be designed for hot water service (ex. copper, cpvc, or qestpex.) Pipes should be installed in a 4" watertight pipe or some other type of insulating means to prevent heat loss from furnace to heating system. Use only copper, brass, or stainless steel fittings. Do not use galvanized or black iron.

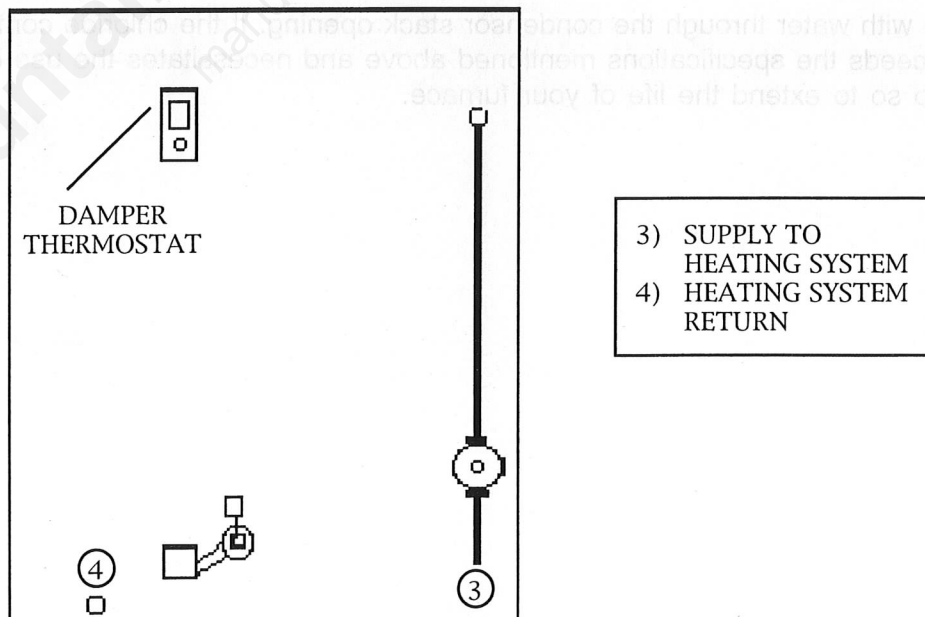

Section II 2 - 9 Filling the Furnace with Water

When you are ready to replace the cover, the hull can slide down over the furnace. Be careful to make sure that the condenser tank and smoke stack opening come through the outside cover.

The space between the smoke stack opening and outside cover will need a bead of silicon applied to fill in any openings. The condenser tank stack will also need to be sealed in this manner. The application of silicon to these openings is illustrated by the diagram on the next page.

Inside of the firebox should be rectangular pieces of insulation and stainless steel. The insulation fits between the firebox and ash doors. The stainless steel slides between the two doors to protect the insulation.

After these steps you can install the smoke stack which is the one - three foot section of pipe. The trim should be slid down the smokestack until it sits upon the outside cover.

The condenser stack must also be installed in the condenser stack opening. The trim must also sit snugly upon the outside cover.

DO NOT SEAL THE CONDENSER TANK TO THE CONDENSER TANK LID. THIS IS THE WATER TANK VENT AND MUST NOT BE SEALED.

There are certain parts of the country that have high enough levels of chloride in the water to be harmful to stainless steel tanks. Even though the USDA allows up to 250 parts per million of chloride (salt) in the water as acceptable for drinking, experience has shown that chloride levels as low as 45 parts per million will eventually cause stress corrosion cracking in stainless steel tanks when the water is heated. It is therefore recommended that the customer use rain water or bottled water with a chloride content of less than 15 parts per million or test the water supply for chloride to assure that the water supply does not exceed this criteria.

Fill your furnace with water through the condensor stack opening. If the chloride content of your local water supply exceeds the specifications mentioned above and necessitates the use of bottled or rain water, please do so to extend the life of your furnace.

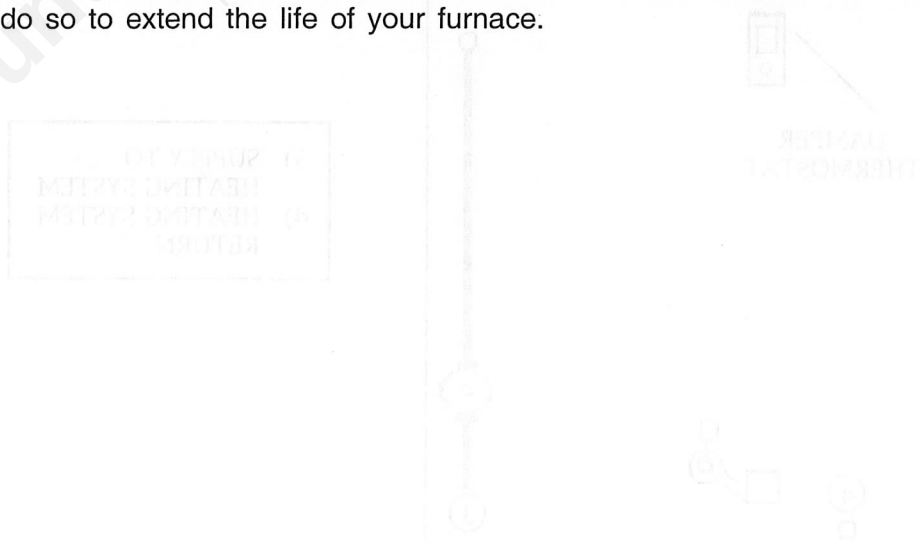

Section II 2 - 9 Filling the Furnace with Water (continued)

THE FURNACE MUST BE FILLED WITH WATER BEFORE STARTING A FIRE.

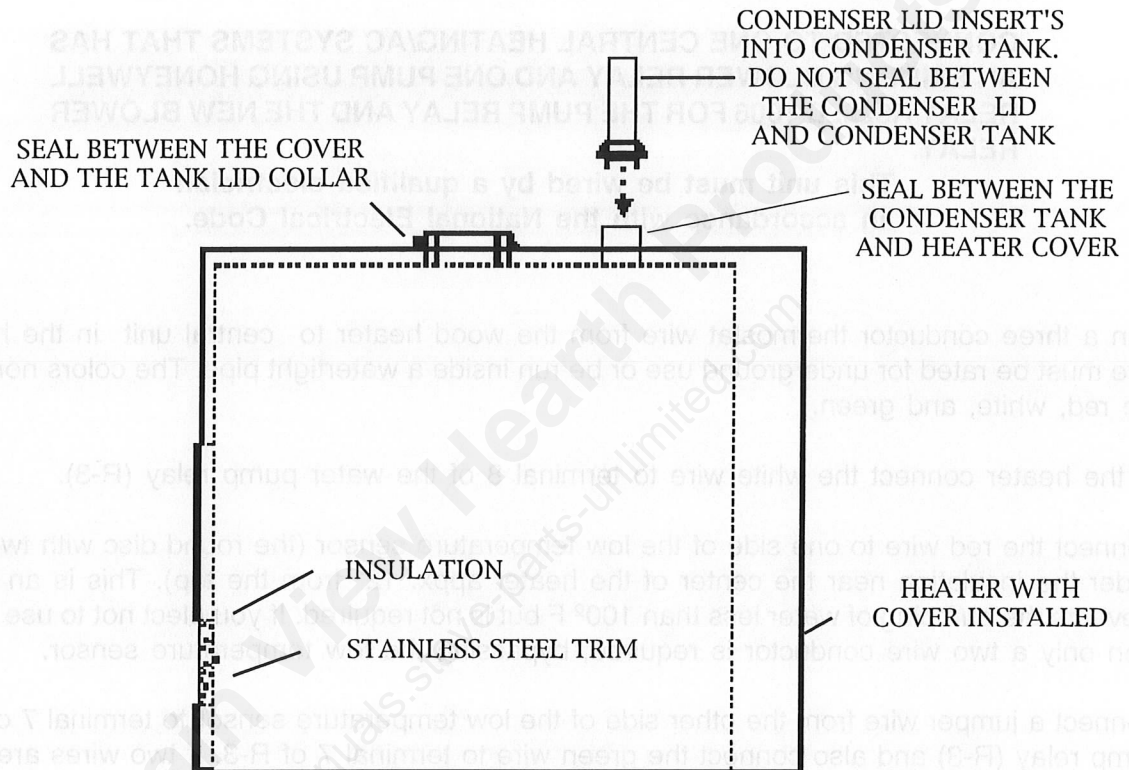

SECTION III

CONNECTION TO CENTRAL HEATING/AC SYSTEM

3 - 1 Connection to Central Unit with existing Blower Relay

CONNECTED TO ONE CENTRAL HEATING/AC SYSTEMS THAT HAS AN EXISTING BLOWER RELAY AND ONE PUMP USING HONEYWELL RELAY R8222D 1006 FOR THE PUMP RELAY AND THE NEW BLOWER RELAY.

This unit must be wired by a qualified electrician in accordance with the National Electrical Code.

1. Run a three conductor thermostat wire from the wood heater to central unit in the house. This wire must be rated for underground use or be run inside a watertight pipe. The colors normally used are red, white, and green.
2. At the heater connect the white wire to terminal 8 of the water pump relay (R-3).
3. Connect the red wire to one side of the low temperature sensor (the round disc with two terminals under the insulation near the center of the heater appx. 12" from the top). This is an option that prevents the pumping of water less than 100° F but is not required. If you elect not to use this option, then only a two wire conductor is required, bypassing the low temperature sensor.
4. Connect a jumper wire from the other side of the low temperature sensor to terminal 7 of the water pump relay (R-3) and also connect the green wire to terminal 7 of R-3. If two wires are used then one is connected to terminal 7 and the other to terminal 8.
5. Inside the house:
 - a. Install the new wood heating thermostat near the existing thermostat;
 1. Remove the cover on the new home heat thermostat to mount it to the wall. There is a round dial visible with an adjustable pointer. This is the heat anticipator. The dial also has a series of numbers. The pointer must be set to the highest number on the dial. On the Honeywell model #(t 822-1016), the pointer is turned counter clockwise as far as it can go.
6. Run a two conductor thermostat wire from the new thermostat to the central unit:
 - a. The colors normally used are red and white.

NOTE: If you are not familiar with the control circuit of your central unit, do not continue beyond this point. Call a heating and air conditioning serviceman to complete the wiring. Improper wiring can cause excessive electrical usage or cause your blower motor to overheat and burn out.

Section III 3 - 1 Connection to Central Unit with existing Blower Relay (continued)

7. Locate the existing 24 volt transformer:
 - A. One 24 volt line (hot) should run from the transformer to the existing thermostat;
 1. Cut this wire and connect the wire going to the existing thermostat to terminal 2 of R-2 (new blower relay).
 2. Connect the wire running from the 24 volt transformer to terminal 1 of R-2 and also connect the red wire of the two conductor thermostat wire to terminal 1 of R-2.
 3. Connect the white wire of the two conductor thermostat wire to the red wire of the three conductor thermostat wire.
8. Locate the other 24 volt line (common) coming from the transformer:
 - A. Splice a white jumper wire to this wire.
 - B. Connect the other end of the white jumper wire to terminal 8 of R-2.
 - C. Also connect the white wire of the three conductor thermostat to terminal 8 of R-2.
 - D. Connect the green wire of the three conductor thermostat wire to terminal 7 of R-2.
 - E. Also connect a jumper wire from terminal 7 of R-2 to terminal 6 of R-2.
9. Locate the existing central unit blower relay (R-1):
 - A. Locate the wire running from the existing thermostat to the blower relay coil; Disconnect this wire from the existing blower relay coil and connect it to terminal 5 of the new blower relay R-2.
 - B. Connect a jumper wire from the existing blower relay coil (the point that you just disconnected) to terminal 4 of relay R-2.
10. If all connections are made properly and the water in the wood heater is hot, the unit should be ready for operation. NOTE: This is a general diagram. You may have to make various changes according to how your unit is wired.

- A. Insure that the compressor on a heat pump or A/C unit does not run when the wood system is running.
- B. Insure that the gas burner, oil burner, or electric elements do not come on when the wood system is running.
- C. Insure that only one speed of the blower motor can be energized at one time. If more than one speed is energized at the same time, the blower motor will burn out.
- D. Insure that the Volt Amp rating of the existing 24 volt transformer is not exceeded when the relays in the wood heating system are energized.

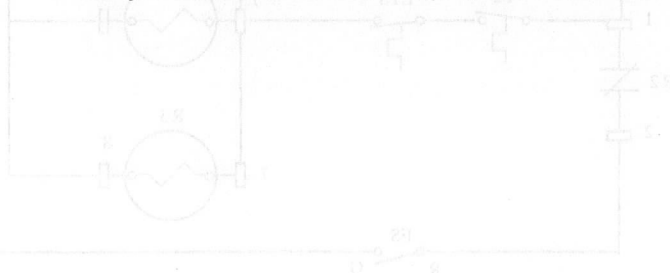

Section III 3 - 1 Connection to Central Unit with existing Blower Relay (continued)

CONNECTION DIAGRAM

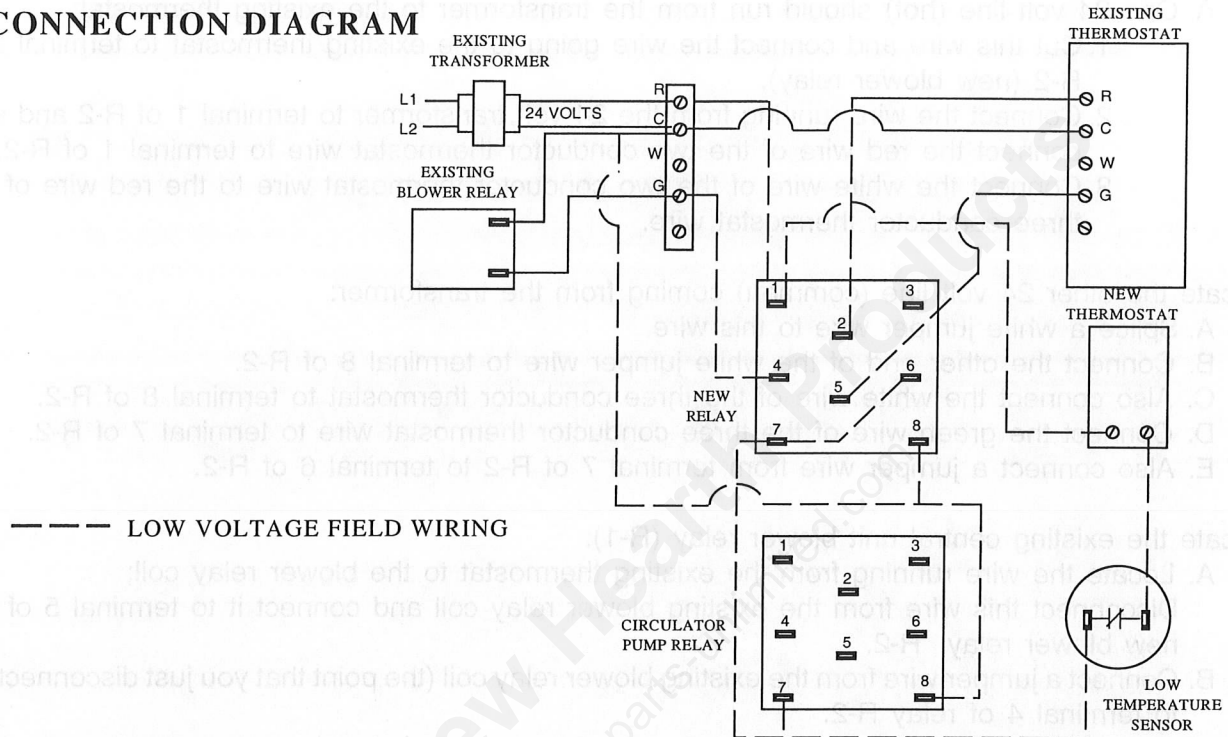

SCHEMATIC DIAGRAM

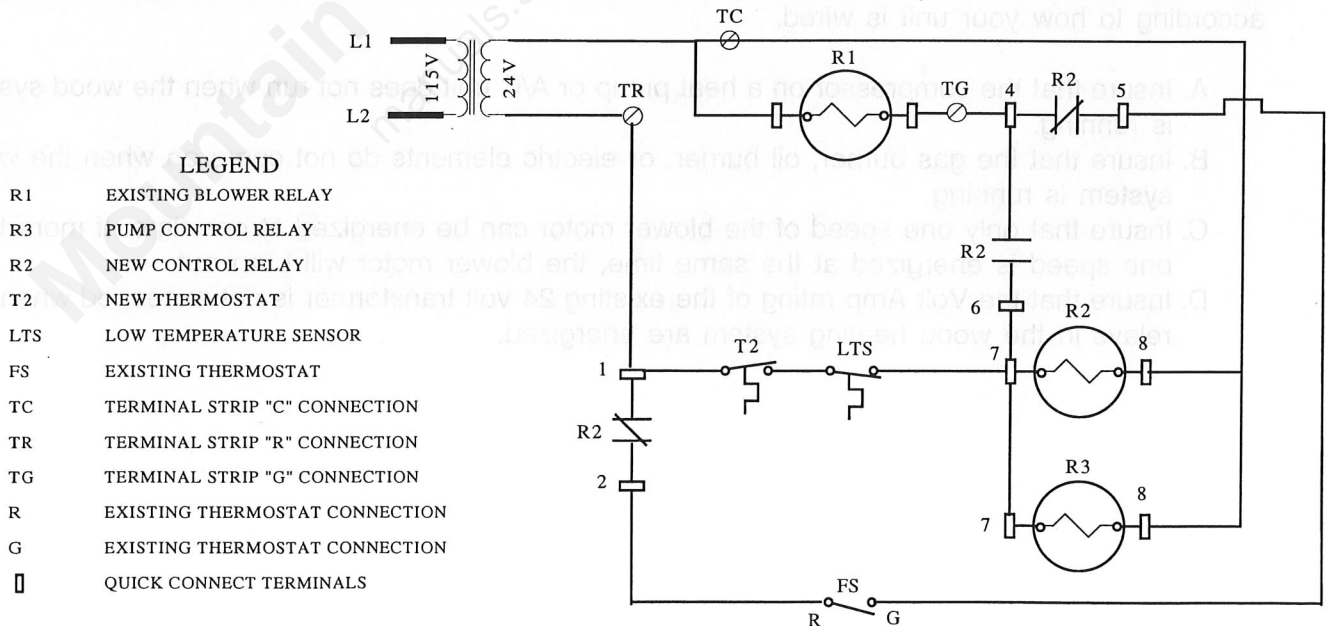

**Section III 3 - 2 Connection to Central Unit
without existing Blower Relay**

**CONNECTED TO ONE CENTRAL HEATING/AC SYSTEMS
(THAT DOES NOT HAVE AN EXISTING BLOWER RELAY)
AND ONE PUMP USING HONEYWELL RELAY
R822D 1006 FOR THE PUMP RELAY
AND THE NEW BLOWER RELAY.**

**This unit must be wired by a qualified electrician
in accordance with the National Electrical Code**

1. Run a three conductor thermostat wire from the wood heater to central unit in the house. This wire must be rated for underground use or be run inside a watertight pipe. The colors normally used are red, white, and green.
2. At the heater connect the white wire to terminal 8 of the water pump relay (R-3).
3. Connect the red wire to one side of the low temperature sensor (the round disc with two terminals under the insulation near the center of the heater appx. 12" from the top). This is an option that prevents the pumping of water less than 100°F but is not required. If you elect not to use this option, then only a two wire conductor is required, bypassing the low temperature sensor.
4. Connect a jumper wire from the other side of the low temperature sensor to terminal 7 of the water pump relay (R-3) and also connect the green wire to terminal 7 of R-3. If two wires are used, then one is connected to terminal 7 and the other to terminal 8.
5. Inside the house:
 - A. Install the new wood heating thermostat near the existing thermostat;
 1. Remove the cover on the new home heat thermostat to mount it to the wall. There is a round dial visible with an adjustable pointer. This is the heat anticipator. The dial also has a series of numbers. The pointer must be set to the highest number on the dial. On the Honeywell model #(t 822-1016), the pointer is turned counter clockwise as far as it can go.
6. Run a two conductor thermostat wire from the new thermostat to the central unit:
 - A. The colors normally used are red and white.

NOTE: If you are not familiar with the control circuit of your central unit, do not continue beyond this point. Call a heating and air conditioning serviceman to complete the wiring. Improper wiring can cause excessive electrical usage or cause your blower motor to overheat and burn out.
7. Locate the existing 24 volt transformer:
 - A. One 24 volt line (hot) should run from the transformer to the existing thermostat;
 1. Cut this wire and connect the wire going to the existing thermostat to terminal 2 of R-2 (new blower relay).
 2. Connect the wire running from the 24 volt transformer to terminal 1 of R-2 and also connect the red wire of the two conductor thermostat wire to terminal 1 of R-2.
 3. Connect the white wire of the two conductor thermostat wire to the red wire of the three conductor thermostat wire.

Section III 3 - 2 Connection to Central Unit without existing Blower Relay (continued)

8. Locate the other 24 volt line (common) running from the transformer:
 - A: Splice a white jumper wire to this wire.
 - B: Connect the other end of the white jumper wire to terminal 8 of R-2
 - C: Also connect the white wire of the three conductor thermostat to terminal 8 of R-2.
 - D: Connect the green wire of the three conductor thermostat wire to terminal 7 of R-2.

9. Locate the temperature sensor that is normally used to turn on the blower when using the existing gas, oil, or electric system.
 - A. Connect a jumper wire from one side of the existing sensor to terminal 4 of the new blower motor relay (R-2).
 - B. Connect a jumper wire from the other side of the existing sensor to terminal 6 of the new blower motor relay (R-2).

10. Be sure to use 115 volt wiring for these jumpers. Do not use thermostat wire. If all connections are made properly and the water in the wood heater is hot, the unit should be ready for operation. Note: This is a general diagram. You may have to make various changes according to how your unit is wired.
 - A. Insure that the compressor on a heat pump or A/C unit does not run when the wood system is running.
 - B. Insure that the gas burner, oil burner, or electric elements do not come on when the wood system is running.
 - C. Insure that only one speed of the blower motor can be energized at one time. Additional speeds must be locked out or disconnected. If more than one speed is energized at the same time, the blower motor will burn out.
 - D. Insure that the Volt Amp rating of the existing 24 volt transformer is not exceeded when the relays in the wood heating system are energized.

**Section III 3 - 2 Connection to Central Unit
without existing Blower Relay (continued)**

CONNECTION DIAGRAM

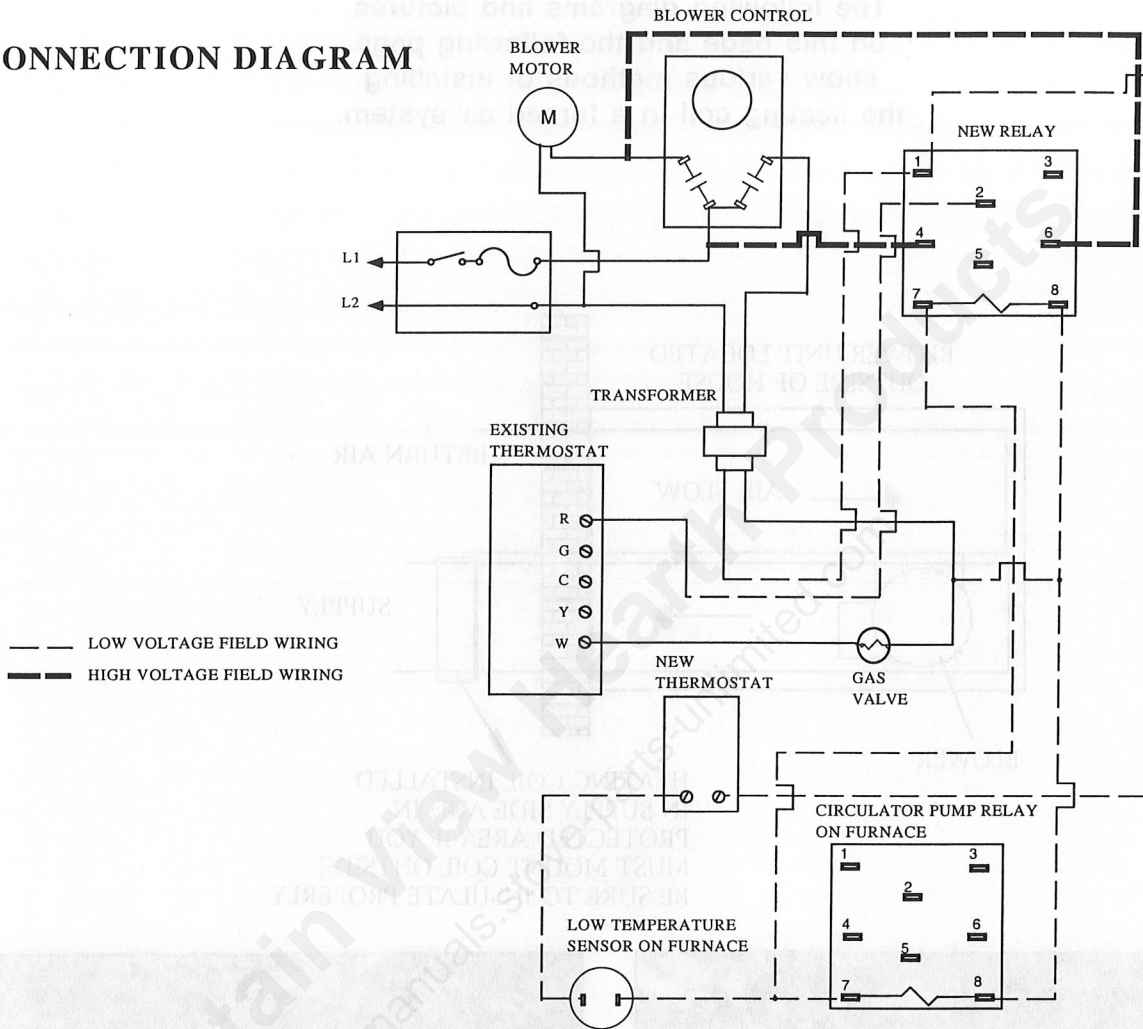

SCHEMATIC DIAGRAM

- LEGEND**
- R3 PUMP CONTROL RELAY
 - R2 NEW CONTROL RELAY
 - T1 EXISTING THERMOSTAT
 - T2 NEW THERMOSTAT
 - M BLOWER MOTOR
 - GV GAS VALVE
 - LTS LOW TEMPERATURE SENSOR
 - FS BLOWER CONTROL
 - QUICK CONNECT TERMINALS

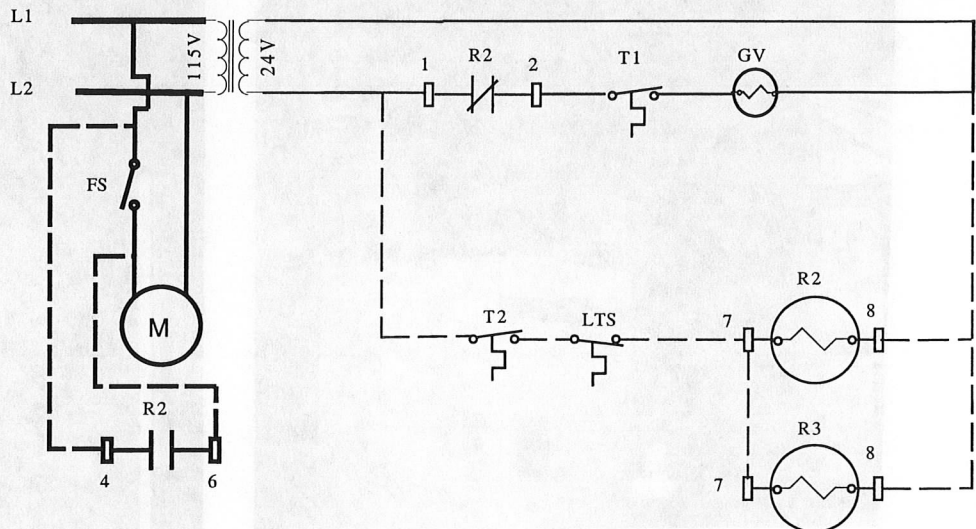

Section III 3 - 3 Location of Heating Coil

The following diagrams and pictures on this page and the following page show various methods of installing the heating coil in a forced air system.

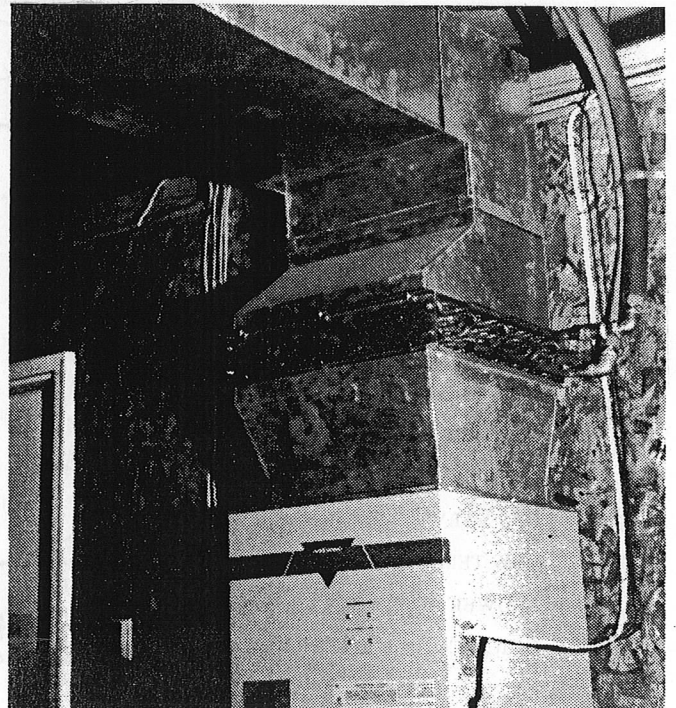
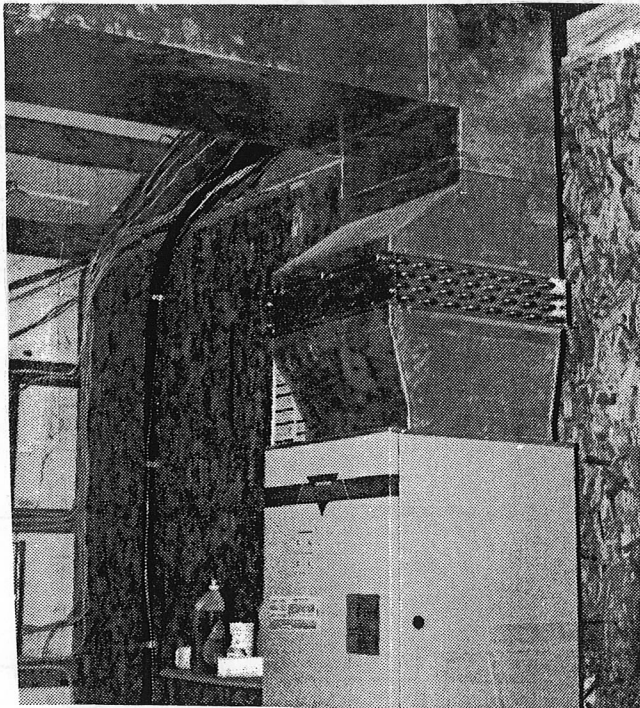
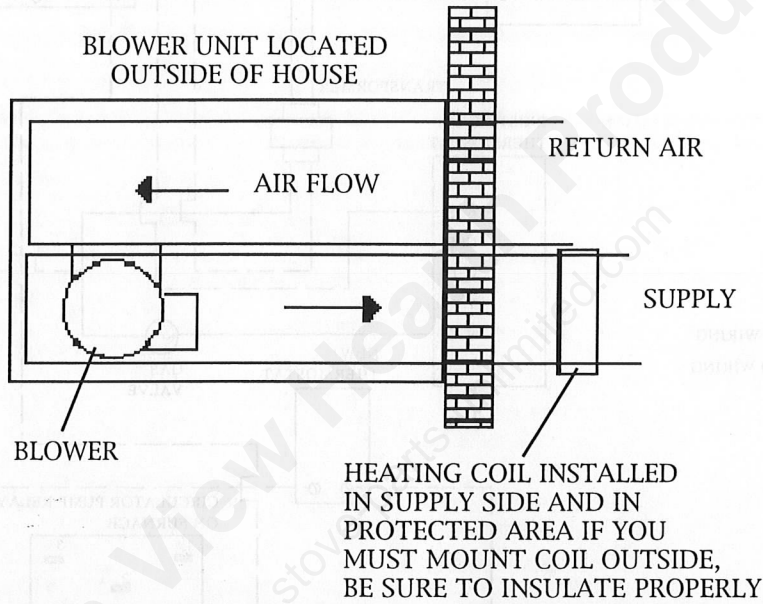

Section III 3 - 3 Location of Heating Coil (continued)

- | | |
|----|--------------------------|
| 3) | SUPPLY TO HEATING SYSTEM |
| 4) | HEATING SYSTEM RETURN |

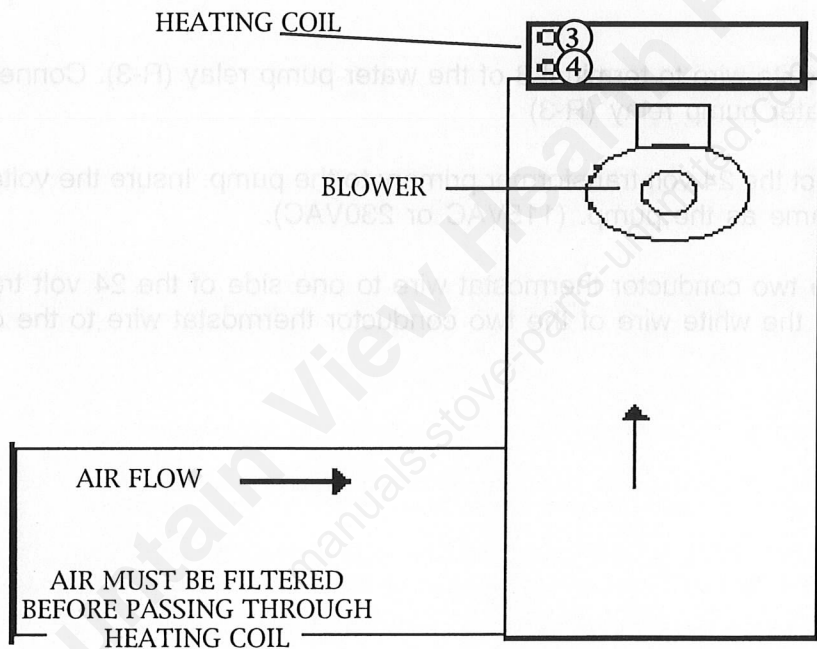

HEATING COIL (DO NOT PLACE CONNECTIONS POINTING UP OR YOU WILL HAVE POTENTIAL AIR LOCK PROBLEMS)

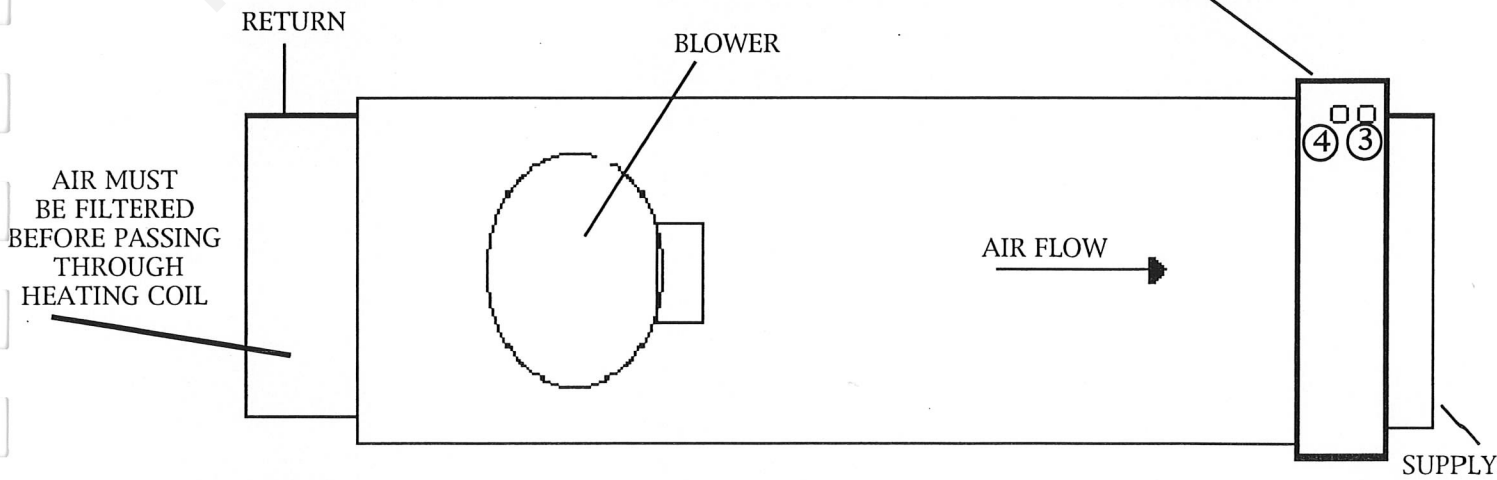

SECTION IV

CONNECTION TO HYDRONIC HEATING SYSTEMS (BASEBOARD)

4 - 1 Connection to Hydronic System with New 24 Volt Transformer

**ONE PUMP ON THE WOOD HEATER
USING HONEYWELL RELAY R8222D.**

**This unit must be wired by a qualified electrician in
accordance with the National Electrical Code.**

1. Run a two conductor thermostat wire from the wood heater to the existing heating system in the house. This wire must be rated for underground use or be run inside a pvc pipe. The colors normally used are red and white.
2. At the heater, connect the white wire to terminal 8 of the water pump relay (R-3). Connect the red wire to terminal 7 of the water pump relay (R-3)
3. At the existing pump, connect the 24 volt transformer primary to the pump. Insure the voltage rating of the transformer is the same as the pump. (115VAC or 230VAC).
4. Connect the red wire of the two conductor thermostat wire to one side of the 24 volt transformer (low voltage side). Connect the white wire of the two conductor thermostat wire to the other side of the 24 volt transformer.

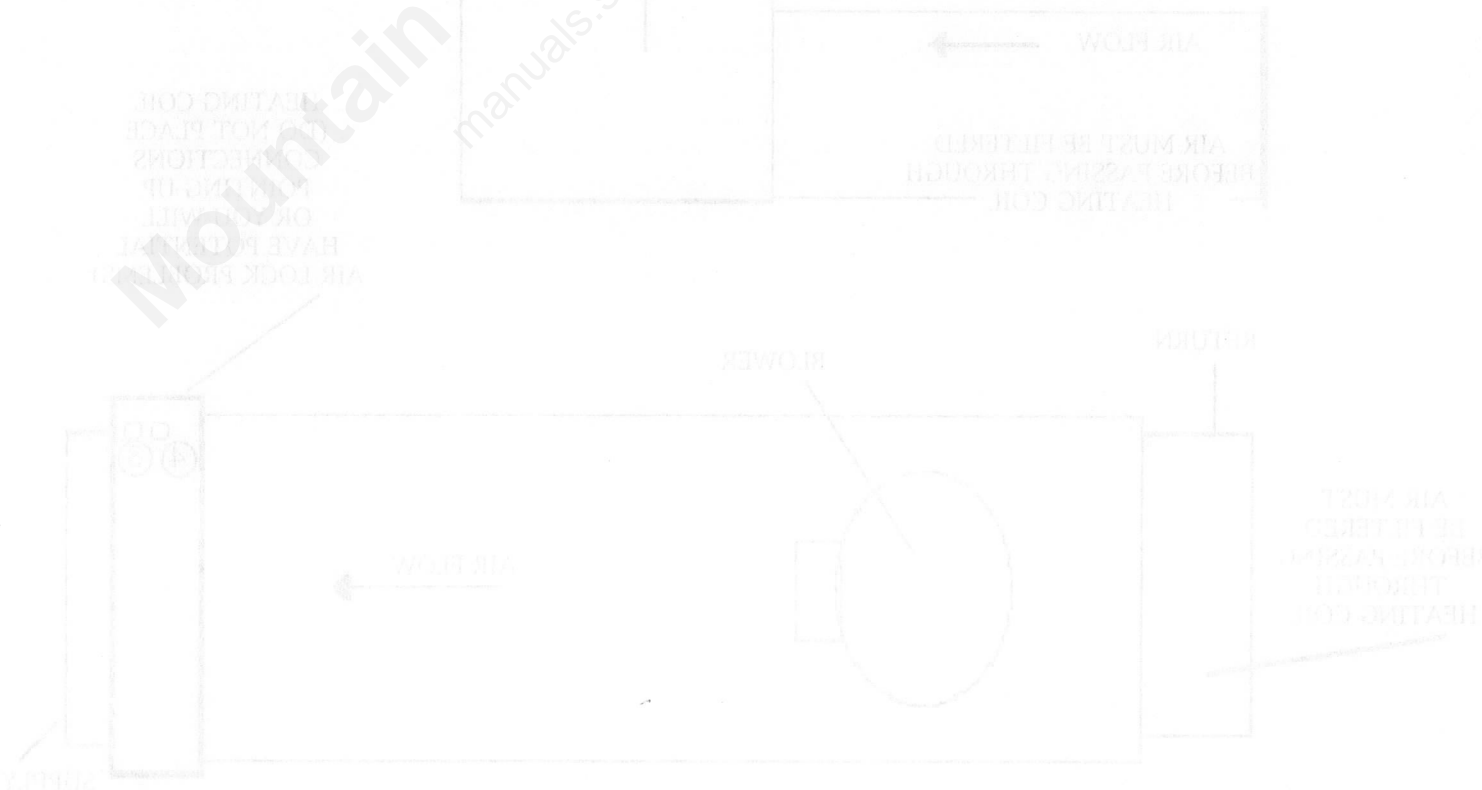

Section IV 4 - 1 Connection to Hydronic System with New 24 Volt Transformer (continued)

CONNECTION DIAGRAM

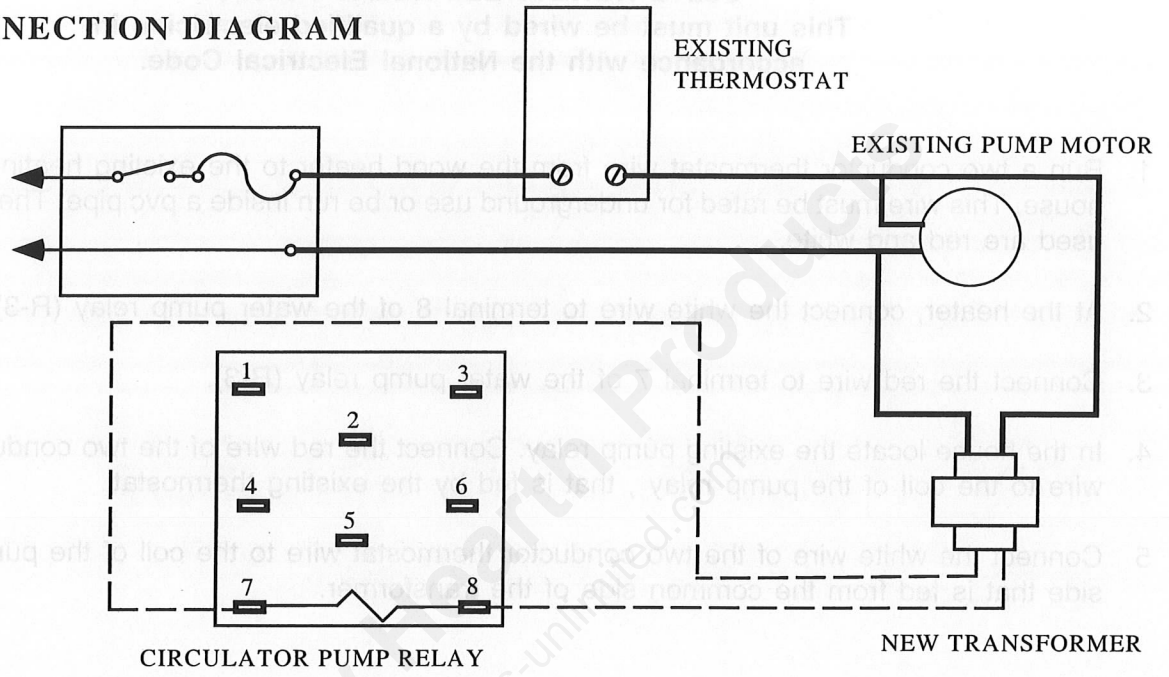

SCHEMATIC DIAGRAM

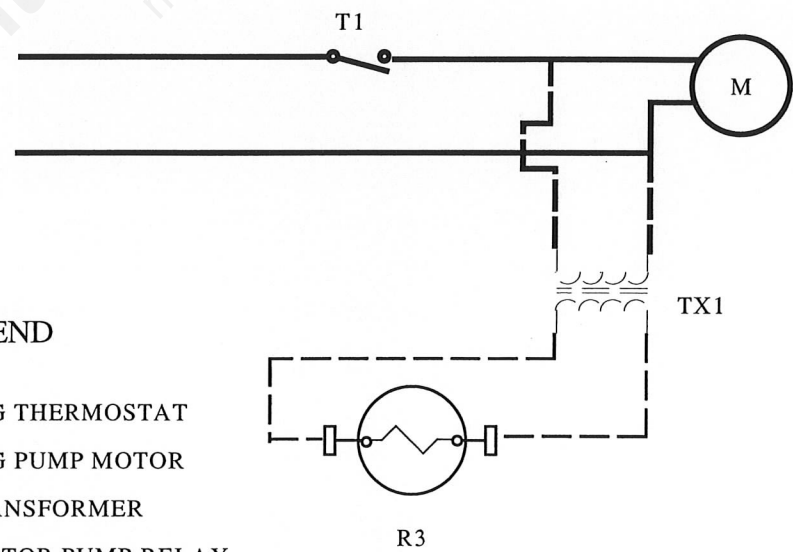

LEGEND

- T1 EXISTING THERMOSTAT
- PM EXISTING PUMP MOTOR
- TX1 NEW TRANSFORMER
- R3 CIRCULATOR PUMP RELAY ON FURNACE

**Section IV 4 - 2 Connection to Hydronic System
with Existing 24 Volt Transformer**

**ONE PUMP ON THE WOOD HEATER
USING HONEYWELL RELAY R8222D.**

**This unit must be wired by a qualified electrician in
accordance with the National Electrical Code.**

1. Run a two conductor thermostat wire from the wood heater to the existing heating system in the house. This wire must be rated for underground use or be run inside a pvc pipe. The colors normally used are red and white.
2. At the heater, connect the white wire to terminal 8 of the water pump relay (R-3).
3. Connect the red wire to terminal 7 of the water pump relay (R-3).
4. In the house locate the existing pump relay. Connect the red wire of the two conductor thermostat wire to the coil of the pump relay , that is fed by the existing thermostat.
5. Connect the white wire of the two conductor thermostat wire to the coil of the pump relay on the side that is fed from the common side of the transformer.



Section IV 4 - 2 Connection to Hydronic System with Existing 24 Volt Transformer (continued)

CONNECTION DIAGRAM

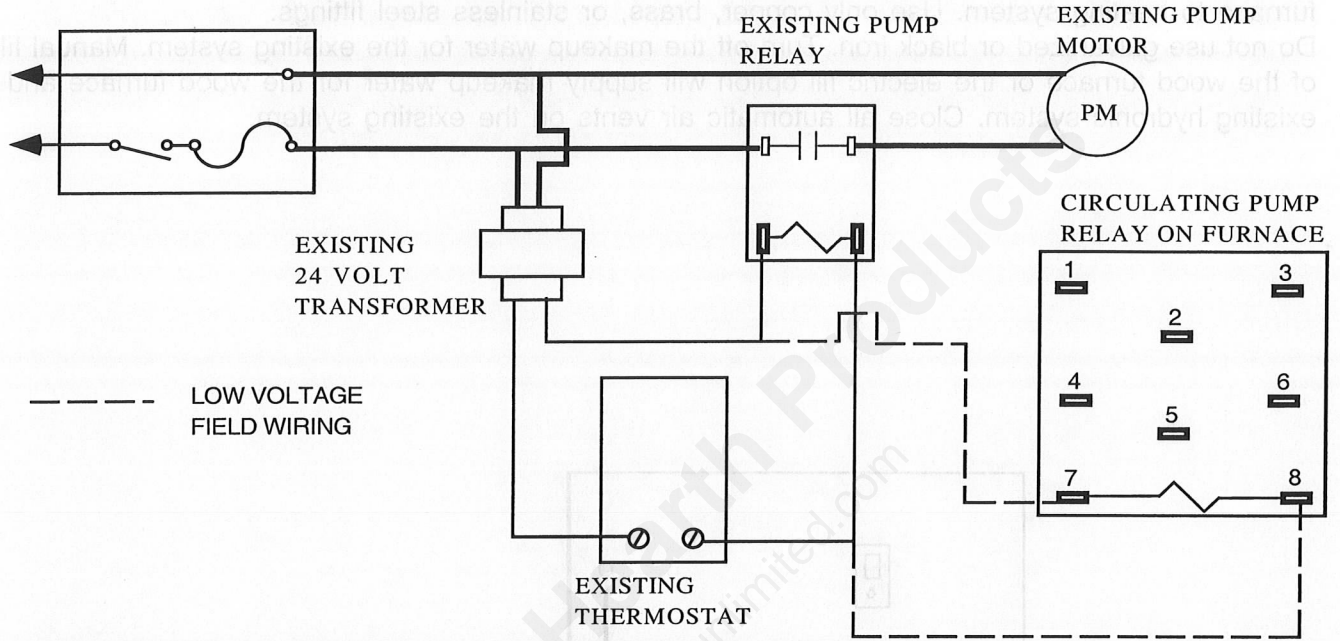

SCHEMATIC DIAGRAM

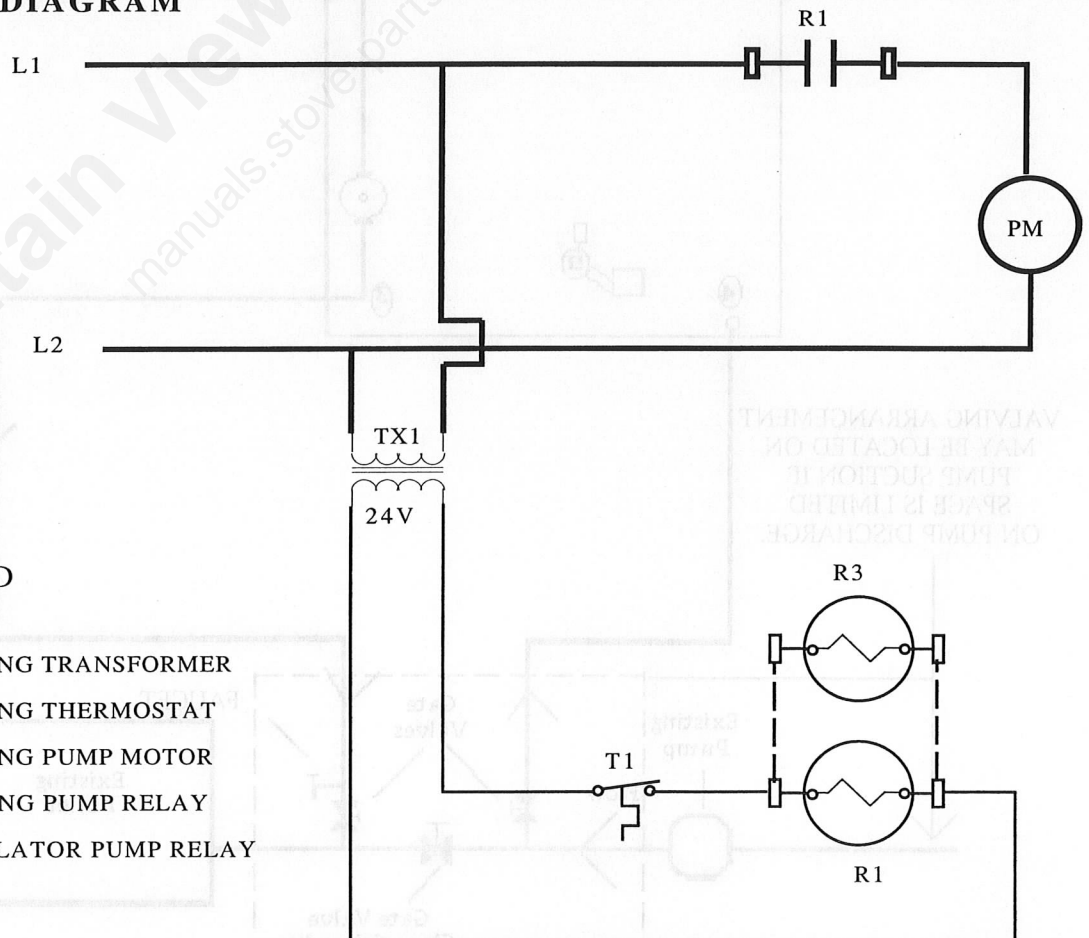

LEGEND

- TX1 EXISTING TRANSFORMER
- T1 EXISTING THERMOSTAT
- PM EXISTING PUMP MOTOR
- R1 EXISTING PUMP RELAY
- R3 CIRCULATOR PUMP RELAY

Section IV 4 - 3 Typical Diagram for Plumbing Hydronic System

Water Pipes must be designed for hot water service (ex. copper, cpvc, or polybutylene.) Pipes should be installed in a 4" watertight pipe or some other type of insulating means to prevent heat loss from furnace to heating system. Use only copper, brass, or stainless steel fittings. Do not use galvanized or black iron. Turn off the makeup water for the existing system. Manual filling of the wood furnace or the electric fill option will supply makeup water for the wood furnace and the existing hydronic system. Close all automatic air vents on the existing system.

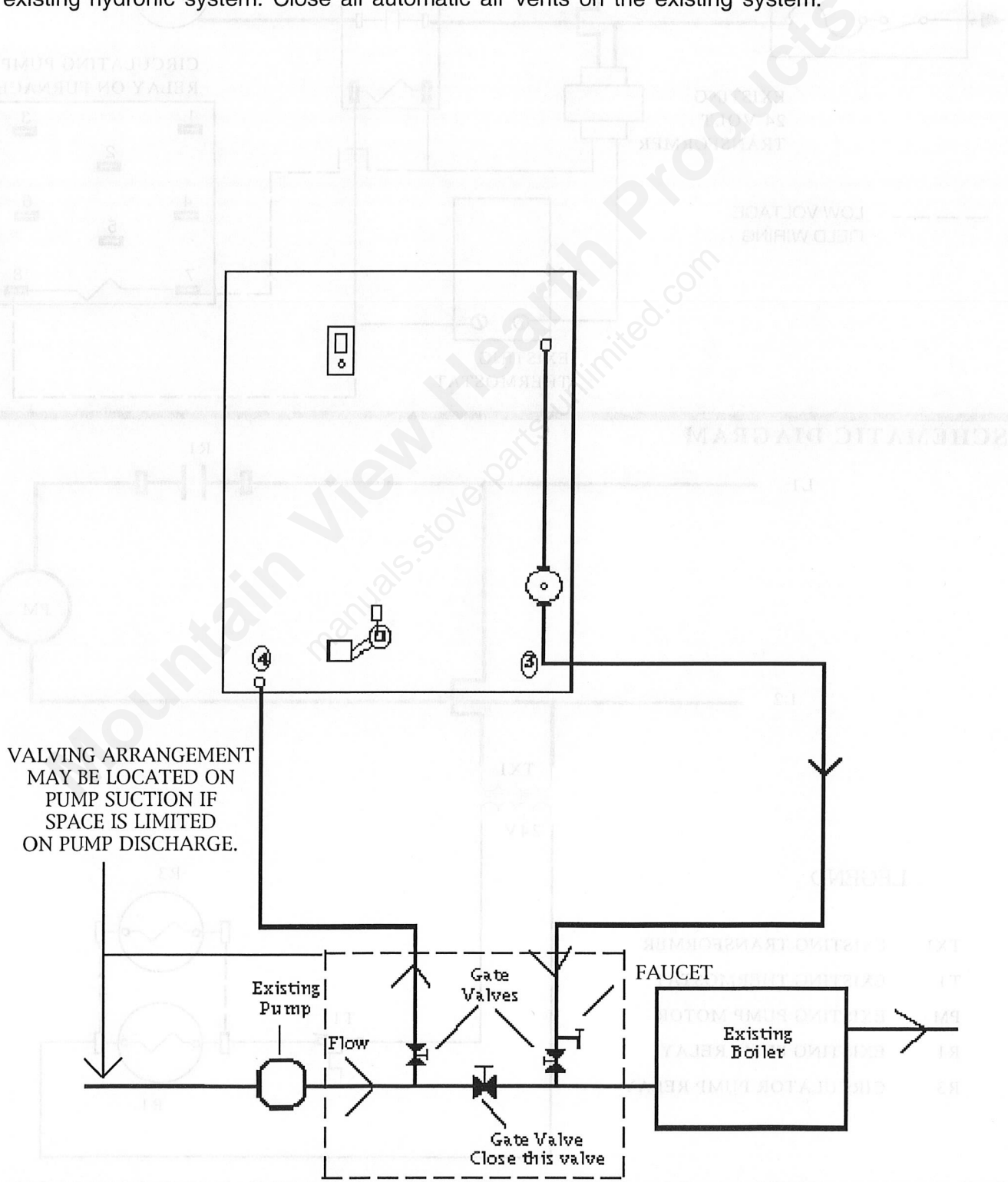

SECTION V

PLUMBING FOR DOMESTIC WATER

Section V 5 - 1 - Plate Heat Exchanger for Domestic Hot Water located on rear of Furnace

The Hardy Cat comes standard with a 007 Taco pump and a plate heat exchanger mounted on the furnace. The pump is mounted on a bottom fitting and pumping up through a plate exchanger located just above the pump. This pump is wired to run continuously .

The domestic water hooks up on the opposite side of the plate heat exchanger. The direction of domestic water flow is reversed from that of the furnace water flow. The cold water supply will go into the top port and the hot water back to the home hot water heater will connect to the bottom port.

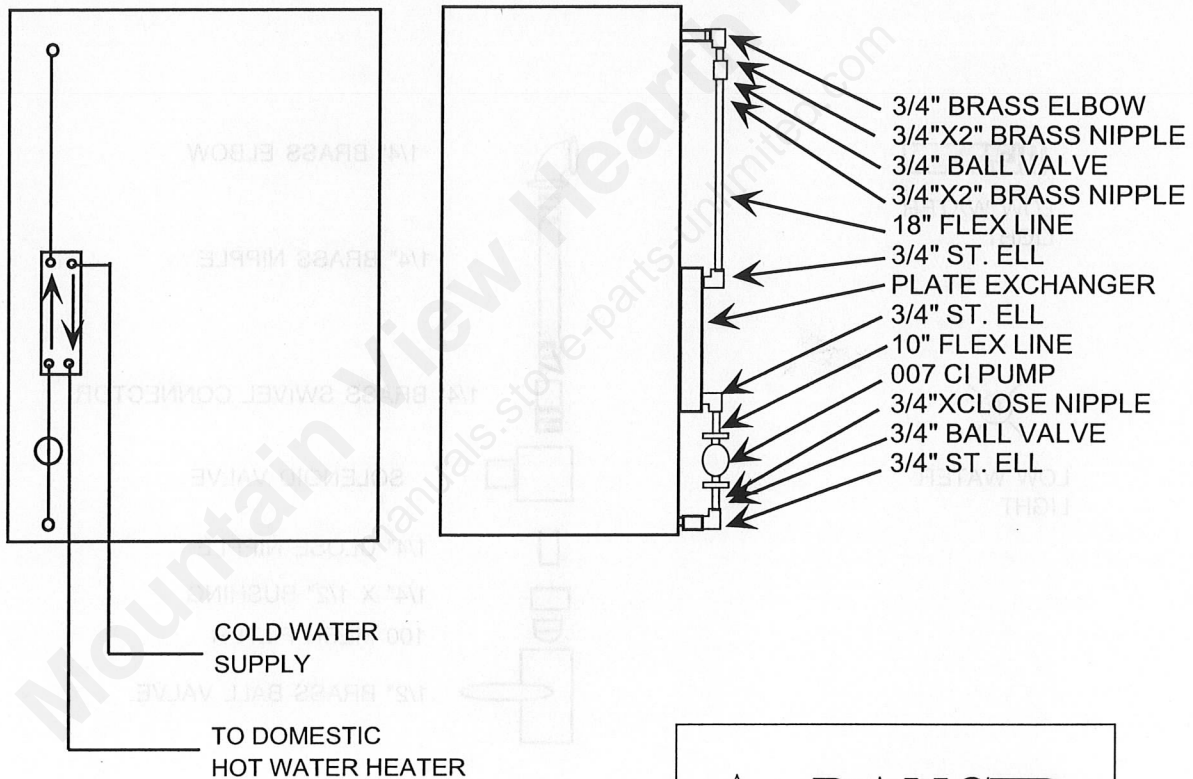

DANGER

WATER TEMPERATURE
OVER 125° CAN CAUSE
SEVERE BURNS INSTANTLY

Section V 5 - 3 Automatic Water Fill

Automatic water fill comes standard an electric water solenoid valve, a low water switch, and various fittings required is installed on the rear of the furnace. It will also require a cold water supply line run to the furnace.

The low water switch is mounted in a 1/2" coupling in the back of the furnace below the condenser tank and operates the electric water valve to allow domestic water to fill the furnace.

The electric water valve is mounted on a 1/4" nipple in the upper right corner on the rear of the furnace.

This will leave a 3/4" hookup. When hooking up your domestic water supply make sure a cutoff valve is installed and flexible connections to remove the screen for annual cleaning. See picture below.

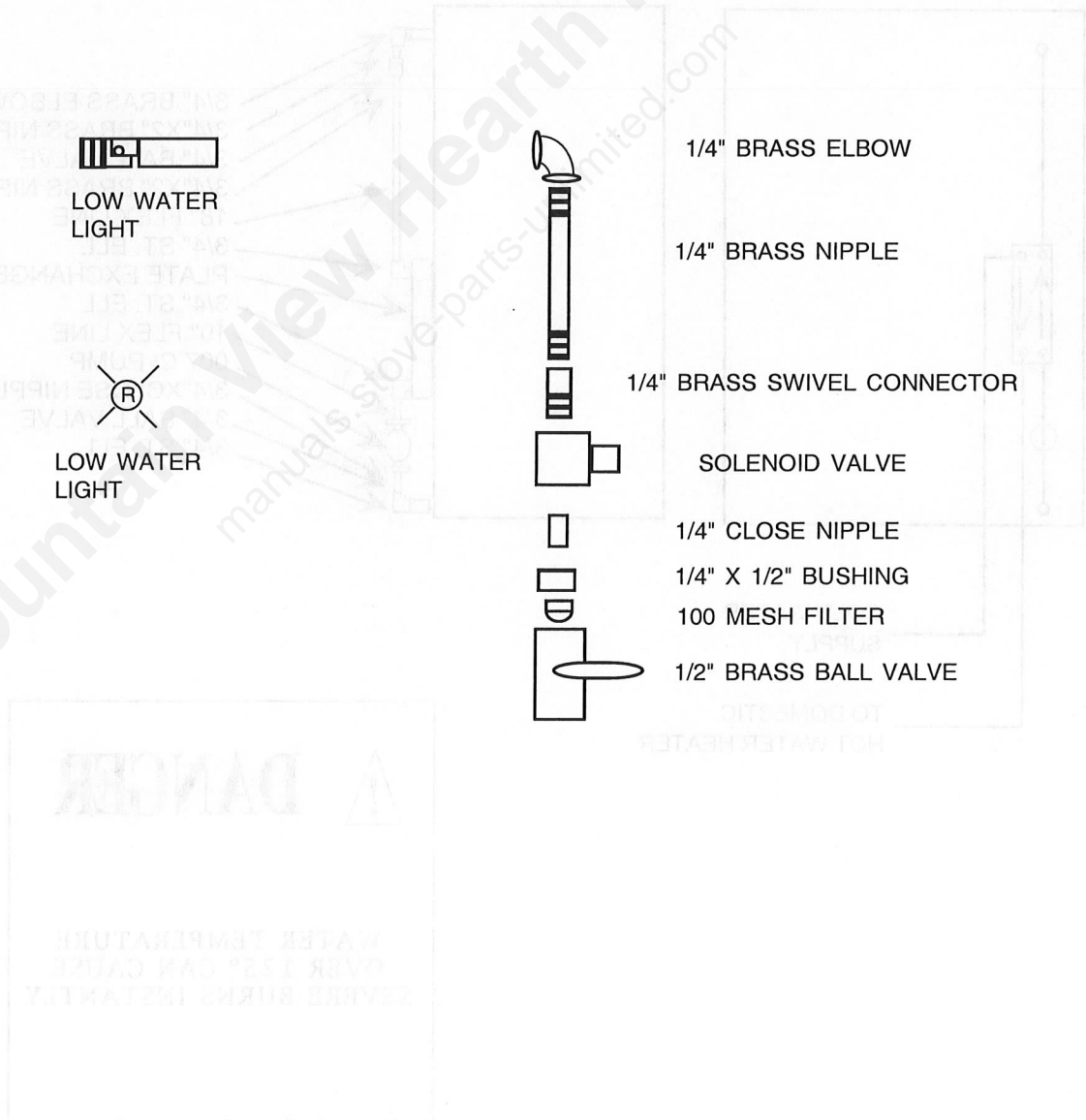

SECTION VI

FURNACE OPERATION

6 - 1 Firing the Furnace

Start the fire as you would in any other wood heater. Do not use petroleum products to start a fire. After you get an initial fire started, always stack the wood in the fire box straight. Do not cross the wood because this can cause the fire to go out. Any time you add wood, fill the fire box completely full. The heater will burn only as much wood as is needed to keep the water hot.

CAUTION: ALWAYS OPEN THE BOTTOM DOOR BEFORE YOU OPEN THE TOP DOOR.

6 - 2 Water Temperature

This furnace has one thermostat. The Dayton thermostat, P/N H2000.16 turns on the draft system, opens the damper lid, turns on the main blower, and turns on the secondary air blower. It operates with a 20 * differential, set at the factory 160* - 180*.

6 - 3 Wood Usage

Never leave the doors open unattended because it will cause excessive wood consumption and could possibly damage the furnace. If the furnace is burning more wood than usual, check the seal around the front doors. If the seal is bad it will need replacing. Call your local Hardy Dealer to request rope and silicon for the particular door.

The fire in the furnace must be out to seal the door. With the door still mounted on the furnace, scrape the old silicone out of the groove. Run a small bead of silicone in the groove of the door. Start installing the rope at the top edge of the wide groove (next to the hinges) running down the hinge side and continue around the door. Run the rope past the starting point to the bottom of the hinge side of the door. The hinge side of the door will have two layers of gasket, press the rope gasket into the groove so that both layers are even.

6 - 4 Moisture in the Firebox

On a new heater or the first time you start a fire each year, you will probably think you have a leak in the firebox. The firebox walls will sweat and water will run down the sides. This can also happen if the water temperature drops below 100° F in the winter. This drop in temperature can be caused by improper burning due to stopped up grates.

If you see moisture in the firebox, wait three days before you get alarmed. If it continues, check to see if you are burning green wood. Green wood will create a lot of moisture in the firebox, even to the extent that water can get as high as an inch or two in the ash pan. Green wood will stop up the catalytic combustors more often and require extra maintenance. If you still think you have a leak in your heater, remove all wood and ashes from the heater. Let it set a couple of days with the doors closed. Then open the ash door. If you have a leak, water will run out of the firebox.

Section VI 6 - 5 Improper Burning

If the heater is not burning properly, remove all of the ashes and wood from the heater. Check to see if the grates are stopped up. Check the air intake at the back of the heater to insure it is clear of ashes. Lift the damper lid to check for ashes. Check to see if the forced air blower is running. **CAUTION :** When servicing the catalytic combustors high temperatures can cause serious burns. You must wear protective equipment. Remove the two combustor housing units from the furnace with the 3/4" square tubing handle provided. Insert the 3/4" tubing into the 1" square opening on each of the combustor housing units and lift up out of the slide tray. Be carefull not to drop the combustor units, as they are fragile. blow any ash out of the combustors with a hair blower set on high heat. Also remove the slide tray from the furnace and clean the entire chamber out. Use a wire brush to dislodge any build up from the top, sides, and bottom of the heat recovery chamber.

6 - 5 Water Temperature

This furnace has one thermostat. The thermostat is located on the front of the furnace. The thermostat is set at the factory at 150° differential. The damper lid turns on the main blower and turns on the secondary air blower. It operates with a 20

6 - 3 Wood Usage

Never leave the door open unattended. Excessive wood consumption and could possibly damage the furnace. If the furnace is burning wood that is not seasoned, check the seal around the front door. If the seal is bad it will need replacing. Call your local Hardy Dealer to request rope and silicon for the particular door.

The fire in the furnace must be out to seal the door. The door is mounted on the furnace, so the old silicone out of the groove. Run a small bead of silicone in the groove of the door. Start installing the rope at the top edge of the wide groove (next to the hinges) running down the hinge side and continue around the door. Run the rope past the starting point to the bottom of the wide side of the door. The hinge side of the door will have two layers of gasket, press the rope into the groove so that both layers are even.

6 - 4 Moisture in the Firebox

On a new heater or the first time you start a fire each year, you will probably think you have a leak in the firebox. The firebox walls will sweat and water will run down the sides. This can happen if the water temperature drops below 100° F in the winter. This drop in temperature can be caused by improper burning due to stopped up grates.

If you see moisture in the firebox, wait three days before you get alarmed. If it continues, check to see if you are burning green wood. Green wood will create a lot of moisture in the firebox, even to the extent that water can get as high as an inch or two in the air part. Green wood will stop up the catalytic combustors over time and require extra maintenance. If you still think you have a leak in your heater, remove all wood and ashes from the heater. Let it sit a couple of days with the door closed. Then open the door. If you have a leak, water will run out of the firebox.

6 - 6 Ash Removal

Ashes must be removed before they build up to the level of the grates. Failure to keep the ash bin cleaned out will result in warped grates. The buildup of ashes in the firebox should be checked at least once a week. Allow the fire to burn down until the grates can be seen. This insures that all of the grates are clear. Failure to do this will cause your heating system to stop working and the grates to warp. If the grates warp slightly, they can be turned over and allowed to straighten out. The drawing shown below shows how the grates should look when you allow the fire to burn down.

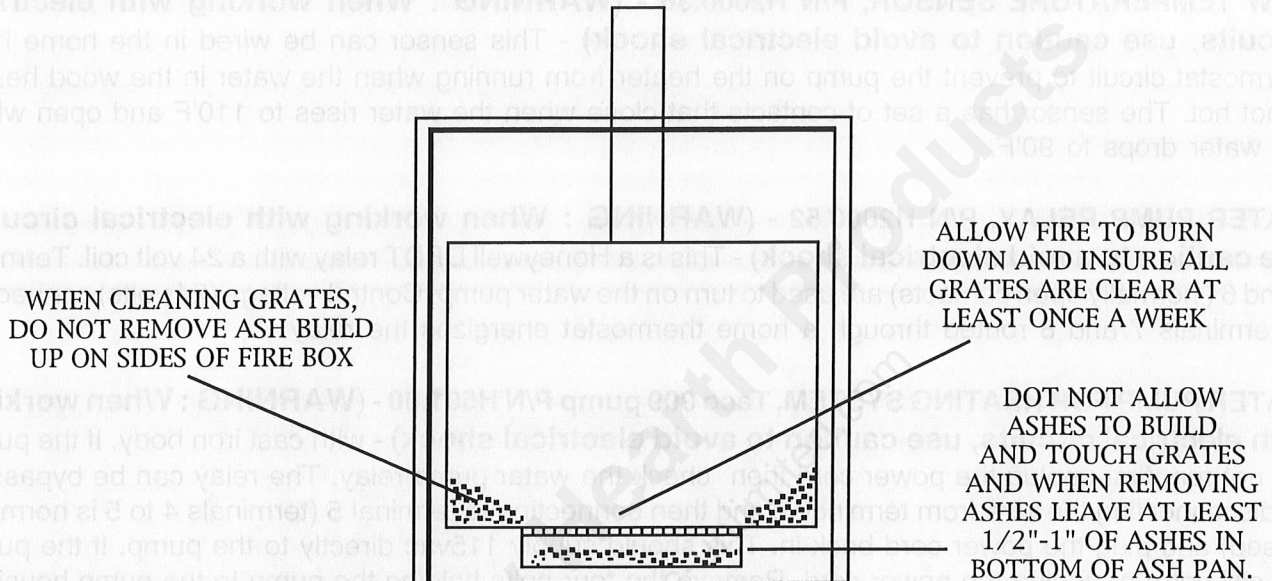

6 - 7 Operating Instructions Summary

1. READ AND UNDERSTAND WRITTEN OWNERS MANUAL
2. FURNACE MUST BE PROPERLY FILLED WITH WATER
3. WARNING - DO NOT USE PETROLEUM PRODUCTS TO START FIRE
4. USE ONLY DRY SEASONED WOOD - USE OF OTHER COMBUSTIBLE PRODUCTS CAN DECREASE LIFE OF CATALYTIC COMBUSTORS
5. FOR PROPER COMBUSTION - AIR MUST FLOW FREELY
 - A. COMBUSTION BLOWER MUST BE CLEAN & FLAP SEALED
 - B. AIR PASSAGE TO BELOW GRATES MUST BE CLEAR
 - C. ASHES MUST NOT BE BUILT UP ABOVE GRATES
 - D. FLAME BUSTER MUST BE CLEAN
 - E. ALL DOORS MUST BE SEALED AND CLOSED
 - F. CATALYTIC COMBUSTORS & CHAMBER MUST BE CLEAN
 - G. SMOKE STACK MUST BE CLEAR
6. WEEKLY MAINTENANCE
 - A. CHECK WATER LEVEL
 - B. CHECK COMBUSTION AIR PASSAGES
 - C. CLEAN FLAME BUSTER BY BRUSHING BOTH SIDES
7. MAINTENANCE AS REQUIRED
 - A. IF FURNACE SMOKES MORE THAN NORMAL, CLEANING OF FLAME BUSTER OR COMBUSTORS IS REQUIRED
 - B. IF SMOKE OR CREOSOTE IS SEEN IN REAR OF FURNACE A COMPLETE CLEANING IS REQUIRED
8. ALLOWING DIRECT FLAME CONTACT ON THE COMBUSTORS WILL DAMAGE THE INTEGRITY OF THE COMBUSTORS
9. OPERATING FURNACE DURING NON-HEATING SEASON IS NOT ADVISED. LOW LOAD CONDITIONS CAUSE THE STOP UP OF COMBUSTORS AND REQUIRE MORE MAINTENANCE

SECTION VII

SERVICE INFORMATION

7 - 1 Water Circulation System

LOW TEMPERATURE SENSOR, P/N H2000.36 - (WARNING : When working with electrical circuits, use caution to avoid electrical shock) - This sensor can be wired in the home heat thermostat circuit to prevent the pump on the heater from running when the water in the wood heater is not hot. The sensor has a set of contacts that close when the water rises to 110°F and open when the water drops to 90°F.

WATER PUMP RELAY, P/N H2000.52 - (WARNING : When working with electrical circuits, use caution to avoid electrical shock) - This is a Honeywell DPDT relay with a 24 volt coil. Terminal 4 and 6 (normally open contacts) are used to turn on the water pump. Control voltage (24 volts) connected at terminals 7 and 8 routed through a home thermostat energizes the relay.

WATER PUMP FOR HEATING SYSTEM, Taco 009 pump P/N H501.00 - (WARNING : When working with electrical circuits, use caution to avoid electrical shock) - with cast iron body. If the pump will not run, first unplug the power cord then check the water pump relay. The relay can be bypassed by disconnecting the wire from terminal 6 and then connecting to terminal 5 (terminals 4 to 5 is normally closed) and plug the power cord back in. This should supply 115vac directly to the pump. If the pump will still not run, unplug the power cord. Remove the four bolts holding the pump to the pump housing. Remove the cartridge from the pump. Spin the impeller by hand to see if the cartridge is locked up. If the impeller will not spin, replace the cartridge. If the impeller will spin, it may have been temporarily stuck (reassemble and try again) or the problem is the electrical winding or capacitor. Use an ohm meter to check the winding and capacitor. If the capacitor is defective, replace it. If the electrical winding is defective, replace the complete pump.

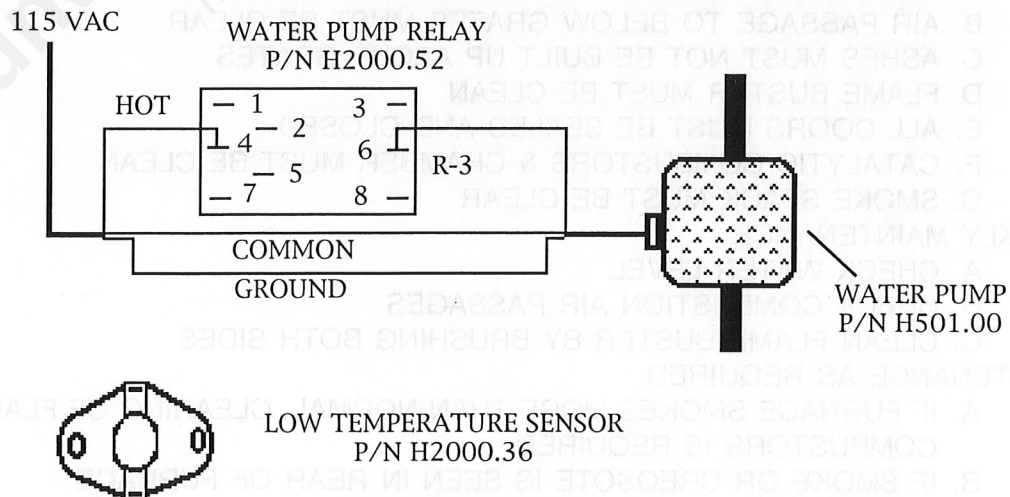

Section VII 7 - 2 Temperature Control System

CATALYTIC COMBUSTOR BYPASS CONTROLS - (WARNING : When working with electrical circuits, use caution to avoid electrical shock) - There is a Zytron temperature controller that senses the smoke stack temperature and moves the catalytic combustors to either operating position or bypass position. When flue gas temperature is high enough for catalyst to work(350°F. - 500°F.) the controllers will move the combustors to the operating position, if flue temperatures drops below catalyst operating temperatures the controllers will move the combustors to the bypass position.

SECONDARY AIR BLOWER, P/N H2002.68 - (WARNING : When working with electrical circuits, use caution to avoid electrical shock) - This blower supplies air to the catalytic combustors so that the smoke will have enough oxygen to react with the catalyst and burn. This motor is lubricated at the factory and requires no further lubrication. It may require cleaning if the vanes of the blower wheel become coated or clogged.

DAMPER THERMOSTAT, P/N H2000. 16 - (WARNING : When working with electrical circuits, use caution to avoid electrical shock) - This furnace has one thermostat. The dayton thermostat, P/N H2000.16 turns on the draft system, opens the damper lid, turns on the main blower, and turns on the secondary air blower. It operates with a 20 * differential, set at the factory 160* - 180*.

DAMPER SOLENOID, P/N H2001.00 - (WARNING : When working with electrical circuits, use caution to avoid electrical shock) - This solenoid lifts the cover off the intake to the forced air draft blower. The solenoid is controlled by the damper thermostat. It should lift the cover when the forced air blower comes on and drop the cover when the blower goes off. If the solenoid does not drop the cover when the blower goes off, the solenoid should be replaced. The forced air draft intake cover must be in place when the blower is not running or the heater will overheat and cause excessive wood usage.

FORCED AIR DRAFT BLOWER, P/N H2002.12 - (WARNING : When working with electrical circuits, use caution to avoid electrical shock) - This blower supplies air to the fire box when the damper thermostat calls for heat. When the blower is not running, all air flow through the blower must be closed off. If the blower wheel or the intake to the blower is clogged, the blower will not deliver the proper amount of air to the fire. The blower can be disassembled and cleaned. Be sure to seal the blower motor back to the blower housing if the blower is disassembled. The motor should be oiled at the beginning of each heating season. When the heater is not in use, the power cord for the blower should be unplugged.

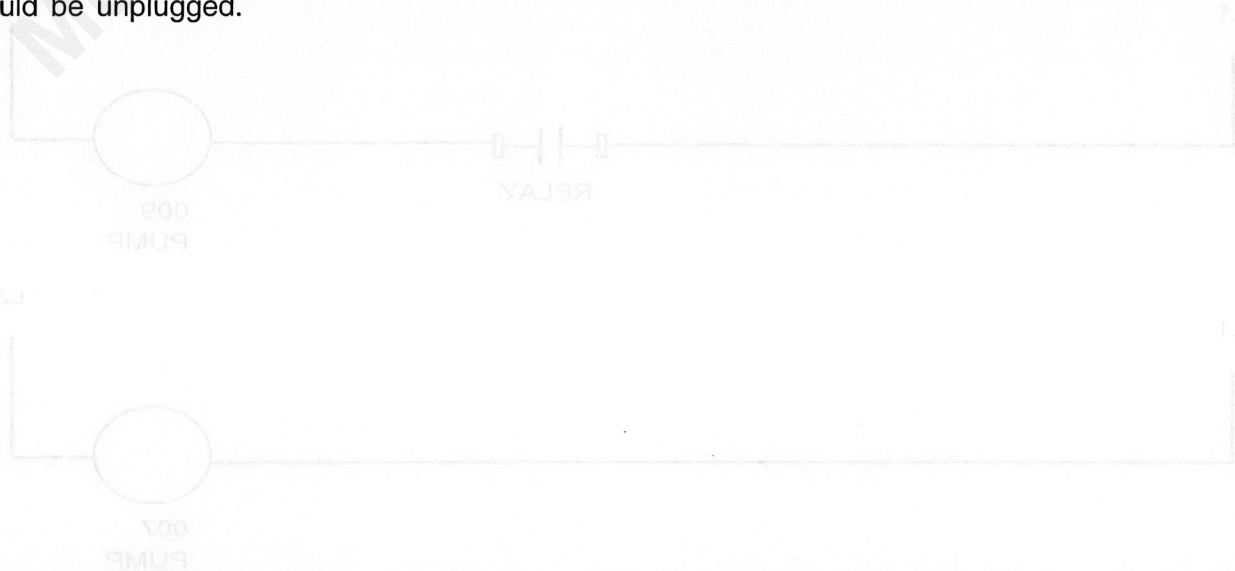

Section VII 7 - 2 Temperature Control System (continued)

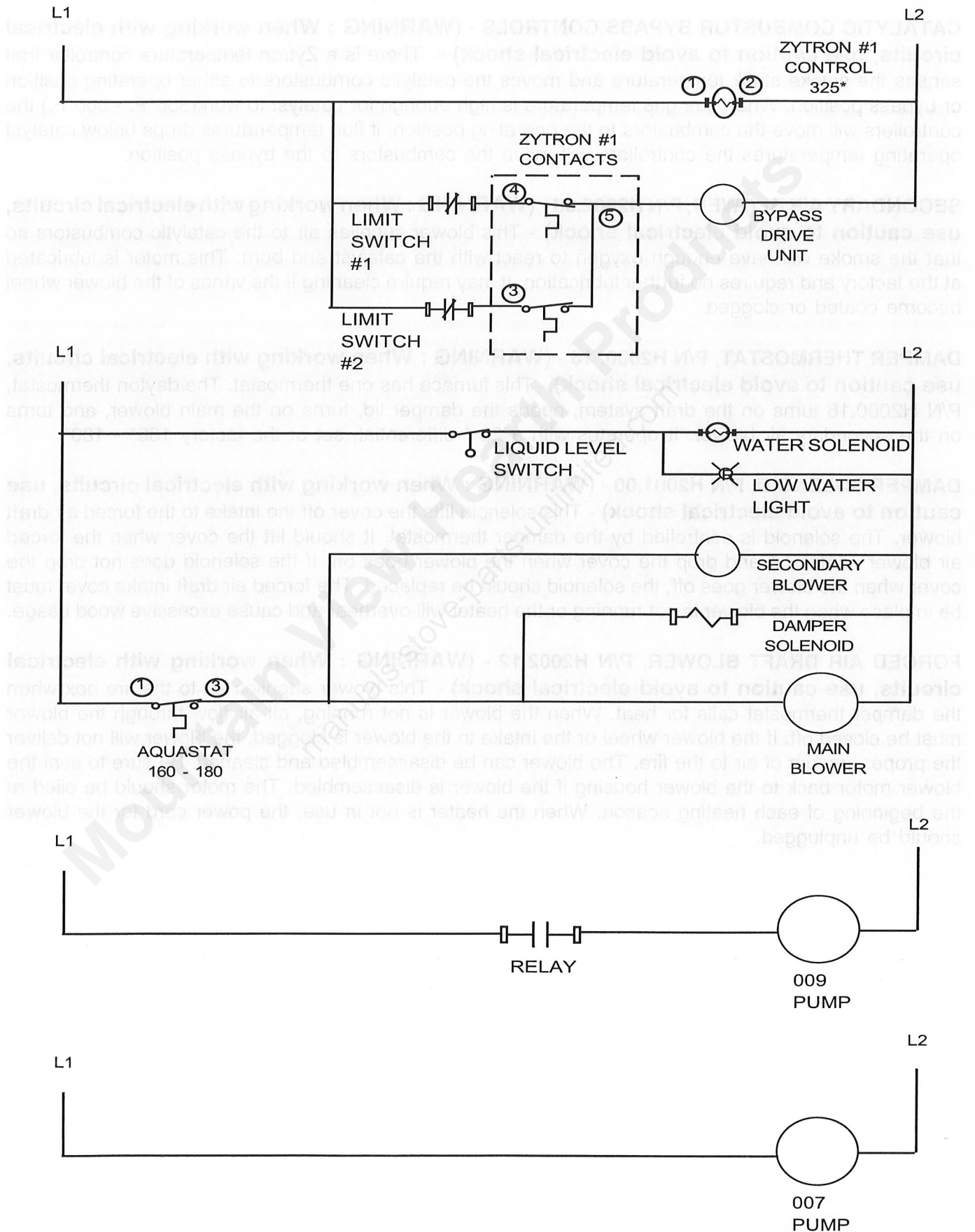

Section VII 7 - 3 Preseason Heater Maintenance

**Each year before the heating season begins,
you should check your furnace to insure
that everything is ready for the heating season.**

1. DAMPER AND DRAFT SYSTEM - When you plugged in the power cord, the damper solenoid should have opened the draft lid on the draft blower. The forced air draft blower should also have come on. If both of these components are working correctly, unplug the power cord. Open the clean out lid beside the draft blower and check for any build up of ash, tar, or any other material that could restrict the amount of combustion air entering the furnace. Check the seal on the clean out lid to assure a good air tight seal is still established. Lift the damper lid on the draft blower and inspect the blower wheel for any build up of lint, dust, creosote, or any other substance that could effect the performance of the draft blower. Spray the damper lid hinge, and the damper solenoid plunger with WD-40, or its equivalent. Oil the draft blower motor with electric motor oil, or 10 weight non detergent motor oil. Do not use WD-40, or machine oil. Check the grates inside the furnace to see if there is any ash build up or if the grates are warped. If a grate does warp, lift that grate up and turn it over. Also at this time check the smoke stack for blockage.

2. WATER PUMP - Unplug the power cord going to the water pump. Close the valve above the water pump and the return water valve at the bottom of the furnace. Remove the pump motor from the pump housing by removing the four bolts in the pump housing. Remove the impeller cartridge assembly from the pump housing. Check the impeller to determine if it is free by spinning the impeller in the cartridge. Check the pump housing for rust or any other build up that could impede the flow of water. Reassemble the water pump, making sure the "O" ring in the cartridge is seated right. Once the pump is reinstalled, open the water valve above the pump and the return valve.

3. CATALYTIC BYPASS SYSTEM - This system should be checked out by a qualified electrician or your local Hardy dealer. The temperature controllers and sensor probes need to be tested for proper operation.

4. CATALYTIC COMBUSTORS - Normal cleaning of the catalytic combustors with the blow dryer will usually be all that is needed. If it becomes necessary for more cleaning than the blow dryer can do, then the combustors can be removed from the combustor housing and washed with plain warm water. The ceramic unit is fragile - so it should be handled with extreme care. To remove the combustors, you will have to cut the gasket material from around the combustor, this will have to be replaced when reinstalling the combustors into the housing. Take the combustors out of the housing and place in warm to hot water, not boiling, for 20 minutes. Then allow the combustors to cool at room temperature and rinse under medium pressure under a faucet. Allow the combustors to dry thoroughly before reinstalling.

Section VII 7 - 4 Trouble Shooting Guide

| COMPLAINT | AREA OF TROUBLE | POSSIBLE CAUSES | CORRECTIVE ACTION |
|--|--------------------|--|--|
| <p>NO HEAT</p> <p>Main power supply and ground fault interrupter receptical "OK"</p> <p>Water Temperature is "HOT"</p> | Pump Performance. | Unplug pump and by-pass pump relay by tying relay wires #4 and #6 together. Plug pump back in. | |
| | Pump does not run. | <ol style="list-style-type: none"> 1. Defective pump cartridge. 2. Defective pump capacitor. 3. Defective pump motor winding. | <ol style="list-style-type: none"> 1. Unplug pump. Remove pump. Pull cartridge from pump and spin impeller by hand. If impeller will not spin, replace cartridge. 2. Use ohmmeter. When the meter is connected to the capacitor, the needle should jump towards "0" ohms and slowly drift back to infinity. Replace if defective. 3. Disconnect the wires connected to the motor terminals to test the motor independent of electrical connections. Check for ground and continuity with ohmmeter. The insulator of the windings should show no breakage. If it does, replace pump. |
| | Pump does run. | <ol style="list-style-type: none"> 1. Defective 24 volt transformer 2. Defective wall thermostat (furnace) 3. Defective low temperature sensor 4. Defective pump relay | <ol style="list-style-type: none"> 1. Located at existing central unit. If 115/120 volts is being supplied to primary side, check for 24 volts on secondary. If 24 volts not present, replace transformer. 2. Inside house. Remove cover. Check wiring for 24 volts. Level the mounting base. Blow dust from sensing bimetal. Adjust heat anticipator. See owners manual connection instructions. 3. Remove wires on sensor and connect to each other to by-pass. If pump runs, replace low temperature sensor. 4. Check relay terminals #7 & #8 for 24 volts reading. If 24 volts is present, use ohmmeter to check contacts. Connect ohmmeter to terminals #4 & #6. If no reading, replace pump relay. If no 24 volts is present, check for continuity of wall thermostat wires. |

Section VII 7 - 4 Trouble Shooting Guide (continued)

| COMPLAINT | AREA OF TROUBLE | POSSIBLE CAUSES | CORRECTIVE ACTION |
|--|--|---|---|
| <p>NO HEAT</p> <p>Main power supply and ground fault interrupter receptical "OK"</p> <p>Water Temperature is "COLD"</p> | Aquastat. | 1. Defective Aquastat | 1. Place a jumper wire across aquastat terminals. If damper solenoid and damper blower operates, replace the aquastat. |
| | Damper Solenoid. (furnace combustion) | 1. Defective damper solenoid | 1. When by-passing aquastat, if solenoid does not lift the cover off the intake to the forced air draft blower, replace solenoid. |
| | Forced Air Draft Blower Motor. (firebox) | Defective blower motor 1. Defective electrical wiring. 2. Air passage stoppage. 3. Blower wheel clogged. | 1. Make sure connectors are secure. 2. Clear air passages in clean-out and damper blower outlet. 3. Clear blower wheel of any lint, ashes or creasote buildup. |
| | Secondary Air Blower Motor. (catalytic) | Defective blower motor 1. Defective electrical wiring. 2. Air passage stoppage. 3. Blower wheel clogged. | 1. Make sure all connections are secure. 2. Remove 1" pipe cap on pipe connected to damper blower and check for clogging. 3. Clear blower wheel of any lint, ashes or creasote buildup. |
| | Ash Bin. | 1. Ash buildup in bin. | 1. Clear ash bin of ash buildup on grates. Ash bin should be cleaned out each week. Ash buildup on grates can cause grates to warp. If grates warp they can be turned over and allowed to straighten. |
| | Flame Buster in top of firebox. | 1. Fly ash buildup. | 1. Clean top and bottom of flame buster. This should be done at least once a week by tapping bottom or brushing. |
| | Catalytic Combustors and Housing. | 1. Fly ash buildup. | 1. See owners manual for proper cleaning procedure. |
| | Heater Stack. | 1. Ash buildup. | 1. Clear heater stack of ash and creasote buildup. |
| | | | |

Section VII 7 - 4 Trouble Shooting Guide (continued)

| COMPLAINT | AREA OF TROUBLE | POSSIBLE CAUSES | CORRECTIVE ACTION |
|---|-----------------------------------|---|---|
| EXCESSIVE WOOD USAGE | Fire Box | <ol style="list-style-type: none"> 1. Doors open. 2. Defective door seals. 3. Damper lid not closing properly 4. T&P Valve leaking. | <ol style="list-style-type: none"> 1. Close all doors and make sure they are securely fastened. 2. If the seal is bad it will need replacing. Call your local Hardy Dealer to request rope and silicone for the particular door. See Owners Manual, (furnace operation section) for replacing door seals. 3. Remove any obstructions causing lid not to close properly. 4. If leaking, replace. |
| IMPROPER BURNING Remove all the ashes and wood | Grates | <ol style="list-style-type: none"> 1. Grates stopped up. | <ol style="list-style-type: none"> 1. Clear grates of ash buildup. If grates are warped, turn them over. |
| | Air Intake | <ol style="list-style-type: none"> 1. Air intake stopped up. | <ol style="list-style-type: none"> 1. Clean air intake at back of heater of possible ash buildup. |
| | Damper Chamber | <ol style="list-style-type: none"> 1. Damper chamber stopped up. | <ol style="list-style-type: none"> 1. Lift damper lid and check for ash buildup. |
| | Forced Air Blower | <ol style="list-style-type: none"> 1. Forced air blower not running. | <ol style="list-style-type: none"> 1. If not running, see <u>NO HEAT</u> section in this guide. |
| | Proper Fuel. | <ol style="list-style-type: none"> 1. Burning green wood. | <ol style="list-style-type: none"> 1. Green wood will create moisture in the firebox and will decrease life of the catalytic combustors. |
| | Flame Buster in top of firebox. | <ol style="list-style-type: none"> 1. Fly ash buildup. | <ol style="list-style-type: none"> 1. Clean top and bottom of flame buster. This should be done at least once a week. See manual for proper cleaning procedure. |
| | Catalytic Combustors and Housing. | <ol style="list-style-type: none"> 1. Fly ash buildup. | <ol style="list-style-type: none"> 1. See owners manual for proper cleaning procedure. |
| | Smoke Stack | <ol style="list-style-type: none"> 1. Smoke stack stopped up. | <ol style="list-style-type: none"> 1. Remove smoke stack and check for creosote buildup. |
| MOISTURE IN FIREBOX | Firebox | <ol style="list-style-type: none"> 1. Yearly startup. 2. Green wood. | <ol style="list-style-type: none"> 1. The firebox walls will sweat and water will run down the sides. This should clear up in three days. 2. Green wood will create moisture in firebox and will decrease life of catalytic combustors. |

Section VIII

Repair Parts

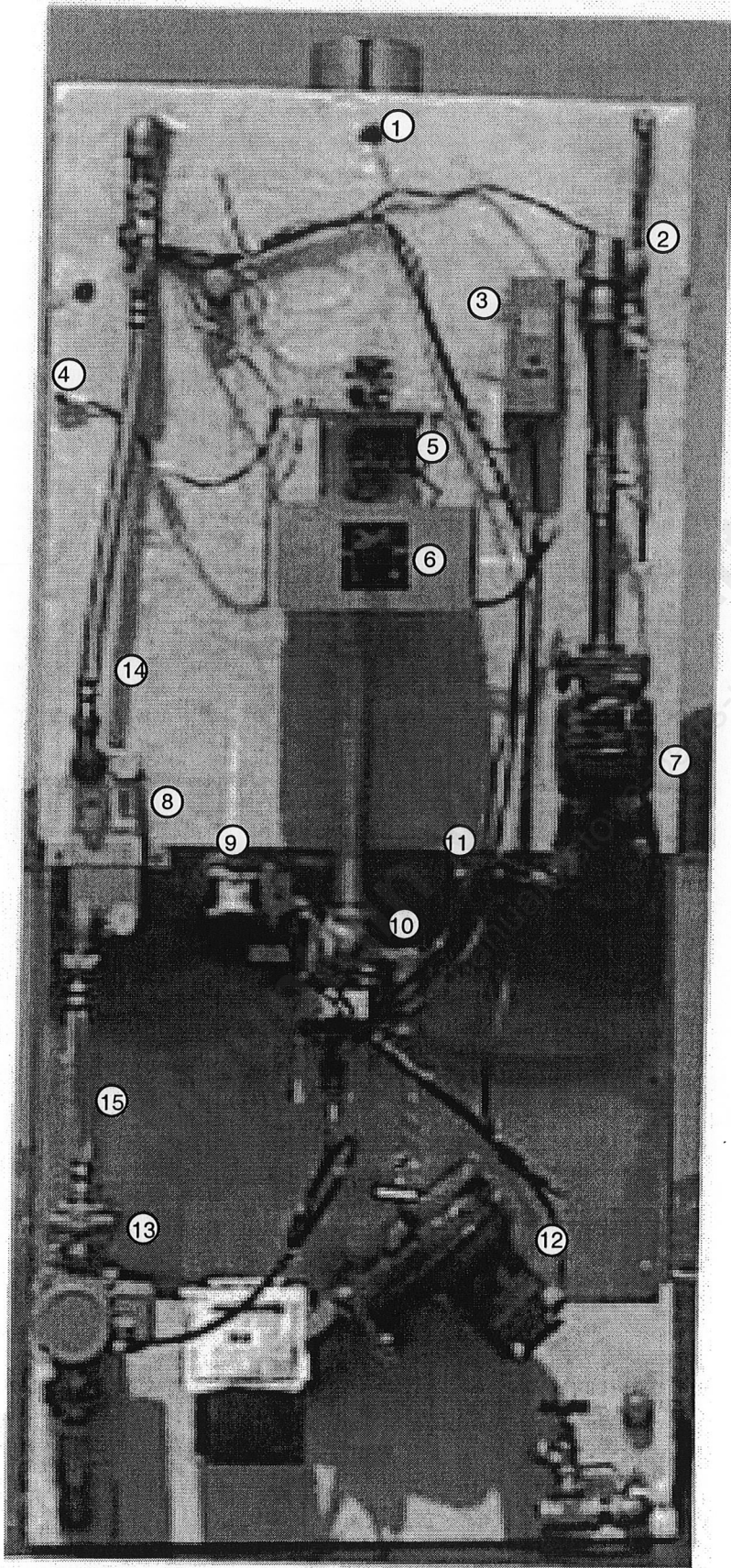

| LEGEND | PART # | DESCRIPTION |
|--------|----------|-------------------------|
| 1 | H1100.27 | LOW WATER SWITCH |
| 2 | H1100.00 | ELECTRIC WATER SOLENOID |
| 3 | H2000.16 | DAYTON THERMOSTAT |
| 4 | H1100.30 | LOW WATER LIGHT |
| 5 | H2620.00 | GEAR MOTOR |
| 6 | H2617.00 | TEMPERATURE CONTROL |
| 7 | H501.00 | TACO 009 PUMP |
| 8 | H300.02 | PLATE HEAT EXCHANGER |
| 9 | H2002.68 | SECONDARY AIR BLOWER |
| 10 | H2001.00 | DAMPER SOLENOID |
| 11 | H2000.52 | RELAY |
| 12 | H2002.16 | 100 CFM BLOWER/LID |
| 13 | H507.00 | TACO 007 PUMP |
| 14 | H700.12 | 3/4" X 18" FLEX LINE |
| 15 | H700.05 | 3/4" X 10" FLEX LINE |

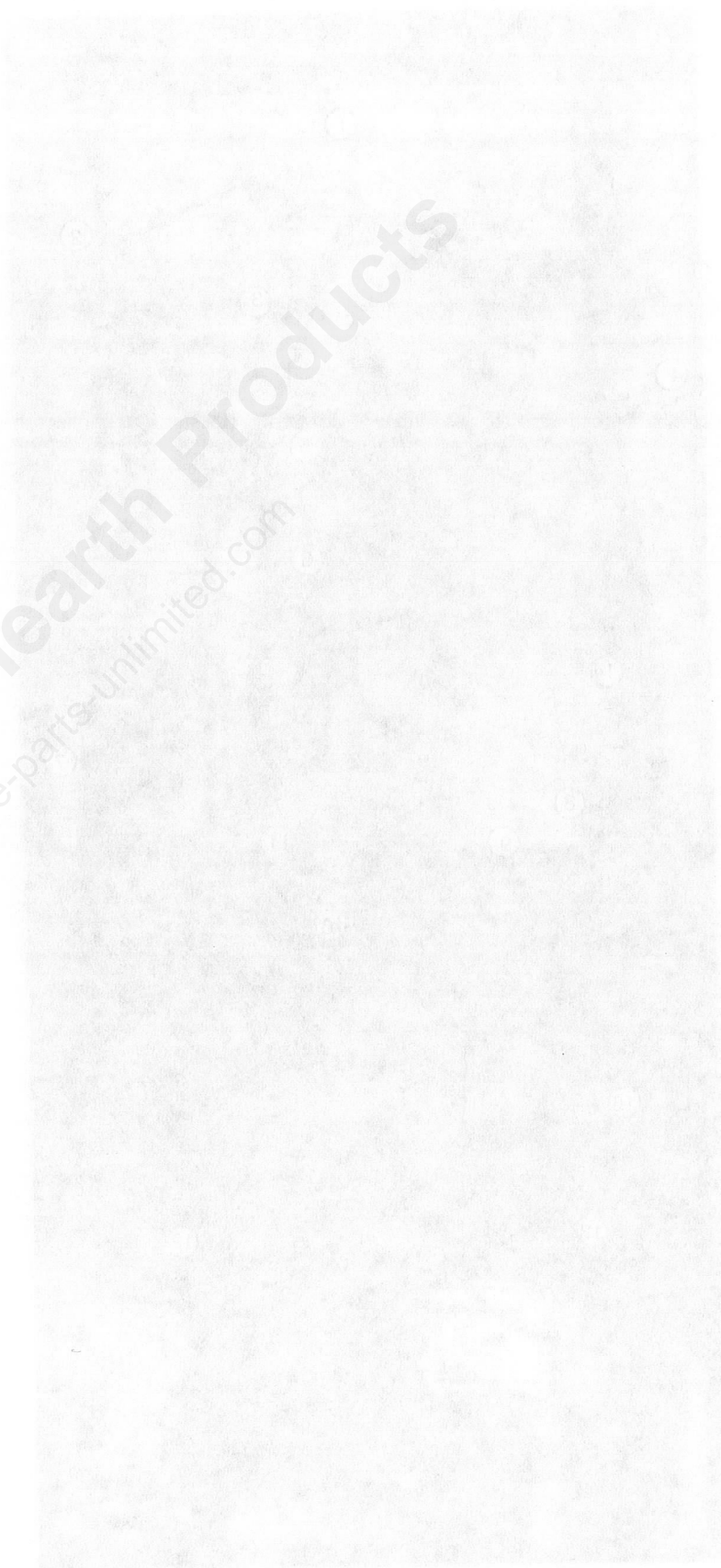

| DESCRIPTION | PART # | LEGEND |
|------------------------|----------|--------|
| LOW WATER SWITCH | H1100.57 | 1 |
| ELECTRIC WATER BOILER | H1100.00 | 2 |
| DAYTON THERMOSTAT | H200.18 | 3 |
| LOW WATER LIGHT | H1100.30 | 4 |
| GEAR MOTOR | F2820.00 | 5 |
| TEMPERATURE CONTROLLER | H301.00 | 6 |
| TACO 008 PUMP | H601.00 | 7 |
| PLATE HEAT EXCHANGER | H500.05 | 8 |
| SECONDARY AIR BLOWER | H300.08 | 9 |
| DAMPER BOILER | H201.00 | 10 |
| PLATE | H200.82 | 11 |
| 100 CFM BLOWER | H100.18 | 12 |
| TACO 007 PUMP | H501.00 | 13 |
| 2" X 18' PEX LINE | H300.15 | 14 |
| 2" X 10' PEX LINE | H200.08 | 15 |

Mountain View Hearth Products
 manuals.stove-parts-unlimited.com