



Shelburne

(Model 8371)

Woodstove

OWNER'S MANUAL

INSTALLATION & OPERATING INSTRUCTIONS



We recommend that our products be installed and serviced by professionals who are certified in the U.S. by NFI (National Fireplace Institute).

www.nficertified.org

Warnock Hersey



PLEASE READ THIS ENTIRE OWNER'S MANUAL BEFORE YOU INSTALL AND USE YOUR NEW Shelburne WOOD STOVE.

If this room heater is not properly installed, a house fire may result. To reduce the risk of fire, follow the installation instructions. Failure to follow these instructions may result in property damage, bodily injury, or even death.

SAVE THESE INSTRUCTIONS FOR FUTURE REFERENCE!

🔥 CONTACT LOCAL AUTHORITIES HAVING JURISDICTION (BUILDING DEPARTMENT or FIRE OFFICIALS) ABOUT PERMITS REQUIRED, RESTRICTIONS, AND INSTALLATION INSPECTION IN YOUR AREA.

Shelburne Model 8371
Manual: 6400-40469
R: 3 - 8/9/11

Intentionally Blank

Mountain View Hearth Products
manuals.stove-parts-unlimited.com

Table of Contents

| | |
|---|-----------|
| INTRODUCTION | 4 |
| SAFETY & GOOD PRACTICES | 5 |
| CODES | 5 |
| PERIODIC CHECKLIST | 6 |
| EMERGENCY PROCEDURES..... | 6 |
| HEARTHSTONE’S THERMO-CERAMIC BAFFLE SYSTEM | 6 |
| SPECIFICATIONS | 7 |
| INSTALLATION | 8 |
| UNPACKING..... | 8 |
| INSTALLING YOUR STOVE | 8 |
| NFPA 211 PROTECTED SURFACES..... | 8 |
| HEARTH REQUIREMENTS AND FLOOR PROTECTION..... | 8 |
| OUTSIDE AIR SUPPLY..... | 9 |
| CLEARANCES TO COMBUSTIBLES | 10 |
| FREESTANDING MINIMUM CLEARANCES..... | 12 |
| CLEARANCES FROM STOVEPIPE | 12 |
| VENTING | 13 |
| COMPONENTS OF A VENTING SYSTEM..... | 13 |
| INSTALLING A VENTING SYSTEM | 13 |
| CONNECTING YOUR WOOD STOVE | 14 |
| REVERSING THE FLUE COLLAR | 14 |
| MOBILE HOME INSTALLATIONS | 17 |
| OPERATION | 18 |
| CONTROLS AND FEATURES..... | 18 |
| CHOOSING FIREWOOD..... | 19 |
| BUILDING A FIRE..... | 20 |
| BREAKING IN YOUR WOOD STOVE..... | 20 |
| BUILDING A BREAK IN FIRE..... | 20 |
| NORMAL OPERATION..... | 21 |
| BUILDING A FIRE FOR EVERYDAY USE | 21 |
| BURN RATE..... | 21 |
| OVER-FIRE CAUTION..... | 21 |
| REMOVAL AND DISPOSAL OF ASHES | 22 |
| MAINTENANCE | 23 |
| MONITORING STOVE TEMPERATURES | 23 |
| CREOSOTE FORMATION & REMOVAL..... | 23 |
| GASKETS | 23 |
| GLASS..... | 23 |
| CAST IRON..... | 24 |
| TROUBLESHOOTING | 25 |
| TROUBLESHOOTING GUIDE | 26 |
| REPLACEMENT PARTS & OPTIONAL ACCESSORIES | 27 |
| SAFETY & RATING LABEL | 28 |

Introduction

Congratulations! You have just invested in a most unique wood burning stove – the Shelburne wood burning stove from Hearthstone Quality Home Heating Products Inc®. The Shelburne Model 8371 is one of the cleanest burning EPA certified, non-catalytic wood burning stoves. At 2.0 cubic feet firebox capacity and a low 2 grams per hour particulate emission rate you can be proud to join the Hearthstone family with our Premier Wood Burning Stove. The generous depth allows for loading of cord wood up to 19 inches long!

Your purchase ensures years of clean, comfortable heat with minimal maintenance. You will receive the benefits of the most advanced technology in wood burning without the cost and maintenance requirements of a catalytic stove. The Shelburne blends modern technology with the unique beauty of cast iron. We trust that you will appreciate the quality of our handcrafted product.

Please read this manual in its entirety. Its purpose is to familiarize you with your stove's safe installation, proper break-in, operation and maintenance. It contains information that will be useful to you now and in years to come, so keep it handy and refer to it as needed.

Use these instructions as well as national, state, and local building codes to install your stove. Ensure you maintain the designated stovepipe and stove clearances to walls, ceilings, hearth, and other combustible surfaces. This will help reduce the risk of fire. Failure to follow these instructions can result in property damage, bodily injury, and even death.

Locate your stove in a safe, convenient, open area; away from traffic flow, doors, and hallways; and near a chimney and chimney connector. Review the proper clearance measurements from combustible surfaces. You can safely reduce required clearances in most cases with a special connector pipe and special wall coverings as specified by this manual, the NFPA 211 codes, and your local authorities having jurisdiction.

As a general rule, keep furniture, drapes, curtains, wood, paper, and other combustibles at least 36 inches (92 cm) away from the stove. Never install the stove in a location where gasoline, kerosene, charcoal lighter fluid or other flammable liquids are used or stored.

The walls of a Hearthstone stove produce an even, radiant heat. Locate the stove centrally in your living area to allow the heat to travel naturally to distant

rooms. Do not locate your stove in an uninsulated basement. The amount of radiant energy required to heat concrete basement walls is so great that most of the usable heat is absorbed by them and lost.

SAFETY NOTICE: A HOUSE FIRE MAY RESULT IF THIS STOVE IS NOT INSTALLED PROPERLY. FOR YOUR SAFETY, CAREFULLY FOLLOW THE INSTALLATION DIRECTIONS. CONTACT LOCAL BUILDING OR FIRE OFFICIALS ABOUT RESTRICTIONS AND INSTALLATION INSPECTION IN YOUR AREA.

The performance of your stove depends on many variables. Since all installations are unique, the general information and operating procedures presented here can only serve as useful guidelines rather than hard and fast rules. Should you have any questions, do not hesitate to contact your dealer for additional information.

Validate your warranty - return your warranty registration card to Hearthstone within 30 days of purchase. Once returning your warranty card has validated your warranty, contact your dealer for any necessary warranty service.

This stove is manufactured and warranted by:

Hearthstone Quality Home Heating Products Inc®
317 Stafford Ave.
Morrisville, VT. 05661
www.Hearthstonestoves.com
inquiry@Hearthstonestoves.com



Safety & Good Practices

Read and understand this Owner's Manual thoroughly before installing and using this stove.

CODES

When you install your Shelburne wood stove, it is imperative that you adhere to all local codes, which can be obtained from either of the following two national sources:

American National Standards Institute, Inc.
(ANSI)
1430 Broadway
New York, NY 10018
www.ansi.org

National Fire Protection Association, Inc. (NFPA)
Battery March Park
Quincy, MA 02269
www.nfpa.org

If you are installing your Shelburne in a mobile home, follow the guidelines described in the Manufactured Home Construction and Safety Standard, Title 24 CFR, Part 3280 (United States).

Ensure you install your stove:

- 🔥 According to the manufacturer's recommendations.
- 🔥 In accordance with all applicable codes.
- 🔥 With the proper sized chimney.

When using your stove:

- 🔥 Warn children and others unfamiliar with woodstoves of the danger of touching hot, radiating surfaces of your stove. For your additional safety, obtain hearth and stove guards through your local dealer.
- 🔥 Follow recommended break-in procedure as outlined in this manual.
- 🔥 Burn natural wood only. Higher efficiencies and lower emissions result when burning air-dried, seasoned wood, as compared to green or freshly cut wood.
- 🔥 Use caution when loading firewood into a hot stove.
- 🔥 Keep the front door closed at all times except when loading wood.
- 🔥 Keep the ash pan tray fully inserted and the ash grate closed.
- 🔥 Inspect the stovepipe, chimney connector and chimney frequently, as recommended.
- 🔥 Be sure the removable ash lip is in place - as it was certified for operation - while using the

stove. If the ash lip is not installed properly, the hearth may exceed safe temperatures.

Follow these safety precautions:

- 🔥 **Never** modify this stove in any way, especially the primary air control system.
- 🔥 **Never** burn kiln dried wood, painted or treated wood, solvents, trash, plywood, colored or glossy paper, artificial logs, cardboard, coal, garbage or driftwood. *Especially, do not burn coal in this stove.*
- 🔥 **Never** Use gasoline type fuel, kerosene, charcoal lighter fluid, or other liquid fuels or solid fire starters to start or invigorate the fire. These fuels can possibly generate carbon monoxide, which can sap the supply of oxygen. Keep all such materials away from the stove.
- 🔥 **Never** use the stove if the ash pan is loose, not present, or if the ash grate is open.
- 🔥 **Never** use a wood grate or other device to elevate the fire.
- 🔥 **Do Not** allow logs to rest against or otherwise come in contact with the glass when the door is closed.
- 🔥 **Do Not** slam the door or use it to force wood in to the stove.
- 🔥 **Never** over-fire your stove. (See page 21)
- 🔥 **Never** put articles of clothing or candles on a hot stove.
- 🔥 **Do Not** connect the stove to a flue that is serving another appliance. (See page 13)

Other safety guidelines:

- 🔥 As a general rule, keep all combustible items such as furniture, drapes, clothing, and other items, at least 36" (0.92 m) from the stove (See page 10)
- 🔥 Install a smoke detector.
- 🔥 Keep a fire extinguisher handy. We recommend the type rated "A B C."
- 🔥 Dispose of ashes properly. (See page 22)
- 🔥 Keep children and pets away from the stove; they could be burned by touching a hot stove.
- 🔥 Clean your stove and vent system as needed. (See page 23)
- 🔥 Outside combustion air may be required if:
 1. This solid-fuel-fired appliance does not draw steadily, smoke rollout occurs, fuel burns poorly, or back-drafts occur whether or not there is combustion present.
 2. Existing fuel-fired equipment in the house, such as fireplaces or other heating

appliances, smell, do not operate properly, suffer smoke roll-out when opened, or back-draft whether or not there is combustion present.

3. Opening a window slightly on a calm (windless) day alleviates any of the above symptoms.
4. The house is equipped with a well-sealed vapor barrier and tight fitting windows and/or has any powered devices that exhaust house air.
5. There is excessive condensation on windows in the winter.
6. A ventilation system is installed in the house.

If these or other indications suggest that infiltration air is inadequate, additional combustion air should be provided from the outdoors. Outside combustion air can be provided to the appliance by using the optional outside air kit 93-53700.

PERIODIC CHECKLIST

Perform each of these tasks at the specified intervals.

Weekly:

- 🔥 Empty ashes from the firebox and ash pan, sooner if the firebox or the ash pan begins to fill up.

Monthly:

- 🔥 Visually inspect chimney connector and chimney for creosote; clean accordingly.

Bi-monthly:

- 🔥 A visual inspection of the chimney connector and chimney for creosote is recommended depending upon your use of the stove. (Refer to page 23 – Creosote Formation and Need For Removal)
- 🔥 Check door seals using the "dollar bill test." - When the fire is out and the stove is cool, shut the door on a dollar bill. If the bill pulls out without any resistance, then your stove's door isn't sealed properly. To tighten the seal, change the door gasket. (Refer to page 23 – Gaskets)

Seasonally:

- 🔥 Dismantle the chimney connector and clean it thoroughly. Replace any pieces that show signs of rust or deterioration.
- 🔥 Inspect and, if necessary, clean your chimney.

- 🔥 Thoroughly clean out the inside of the stove.
- 🔥 Inspect all door gasket material and replace if worn, frayed, cracked or extremely hard.

EMERGENCY PROCEDURES

If you have a stovepipe (connector) or chimney fire, follow these instructions:

1. If the fire is too threatening, leave the area and call the fire department immediately! If not, perform the next three steps.
2. Close the primary air control.
3. Close the stovepipe damper (if present).
4. Keep the stove front, side and ash doors closed!

🔥 **WARNING: DO NOT ATTEMPT TO PUT OUT A STOVEPIPE OR CHIMNEY FIRE BY THROWING WATER ONTO THE STOVE, STOVEPIPE, OR CHIMNEY. THE EXTREMELY HIGH TEMPERATURE ASSOCIATED WITH SUCH FIRES CAN CAUSE INSTANTANEOUS STEAM AND SERIOUS BODILY HARM.**

Once the chimney fire has expired, leave the primary air control closed and let the fire in the stove die out completely. The stove should not be fired again until the stove, stovepipe, and chimney are all thoroughly inspected for any sign of damage. You must correct any damage before using your stove again.

HEARTHSTONE'S THERMO-CERAMIC Baffle SYSTEM

To enhance the combustion efficiency and reduce the emissions of the fire in your stove Hearthstone has developed an advanced THERMO-CERAMIC baffle system. This system uses a lightweight, durable ceramic material above the burner tubes to maintain the high temperatures in the secondary combustion area and maintain the low emission – high efficiency combustion you desire. This material will not corrode, rust, dissolve or lose its strength, however it is vulnerable to puncture or cracking due to rough handling.

🔥 **PLEASE EXERCISE CARE WHEN LOADING WOOD OR CLEANING YOUR STOVE, NOT TO DAMAGE THE Thermo-Ceramic Baffle**

Located directly above the burner tubes in the firebox, this white, gray, or brown sheet of material will break if wood or cleaning brushes impact it. Be careful when loading and cleaning your stove to not break this material. If this piece is fractured or a hole is punctured, it will cause the stove to function improperly. You must replace the board through a qualified Hearthstone dealer.

Specifications

Maximum Output: 50,000 BTUs per hour of cordwood (based on independent laboratory test results)

Size of Heated Area: Up to 1,800 square feet.

Firebox Capacity: 2.0 cubic feet (.071 cubic meters) or 50 pounds of wood*

*The amount and weight of wood contained per cubic foot of firebox volume can vary from 15 to 36 lbs. per cubic foot depending on type of wood, moisture content, packing density and other factors. As a constant for comparison and test purposes, we are assuming 20 lbs. of seasoned hardwood per cubic foot of firebox volume.

Max Log Length: 19" (48.3 cm) front door

Height: 30-1/2" (73.7 cm)

Width: 26-1/2" (67.3 cm)

Depth: 19" (48.3 cm)

Front Door Size: 19-3/4" wide x 11-3/4" high (501 x 298 mm)

Stovepipe Size: 6" (152 mm) diameter

Metal Chimney: 6" (152 mm) inside diameter

Masonry Chimney: 8" x 8" (203 x 203 mm) (square flue)

Flue Exit: Vertical, or Rear Exit

Optional Equipment: Outside Air Kit, Convection Blower, Rear Heat Shield

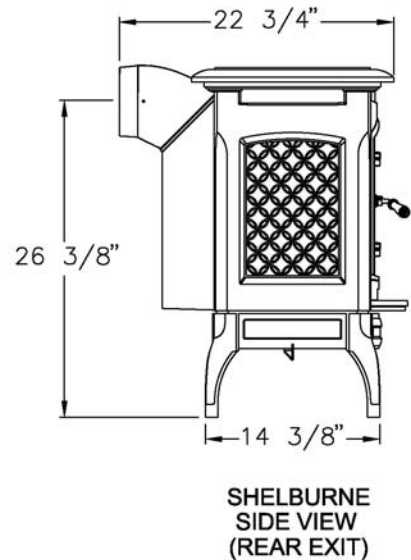
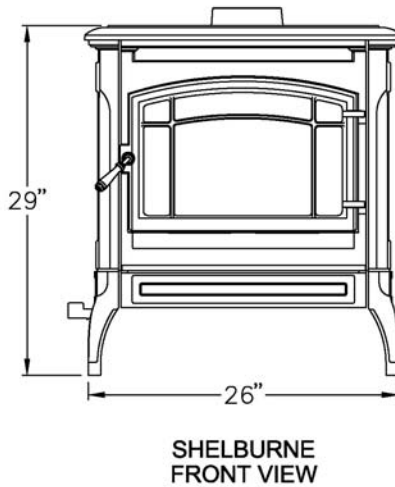
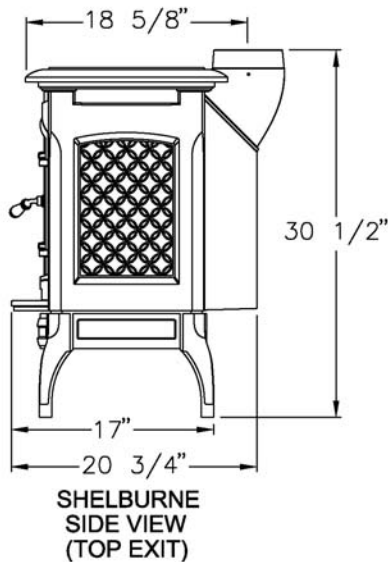
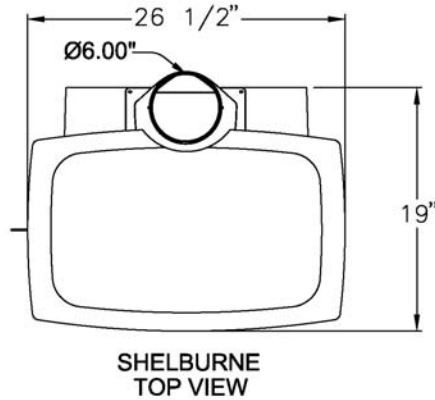

Figure 1 – 8371 Dimensions

Installation

UNPACKING

Hearthstone packages your Shelburne stove with the greatest care so that it ships safely. However, damage can still occur during transit and handling. When you receive your stove, unpack it carefully and inspect all parts for damage. Also, ensure that all parts are included. If any parts are damaged or missing, please contact your dealer immediately.

INSTALLING YOUR STOVE

Read this chapter to obtain a sound understanding of how to properly install your stove. Use this section to plan how to locate your stove in your particular installation. Consider both the clearances of the stovepipe (chimney connector) and the stove itself to the surrounding combustibles.

Choose an appropriate install location to ensure that the stove will have enough clearance to any surrounding combustible materials. These combustibles can include walls, floor, ceiling, fireplace mantles, and chimney coverings. You must carefully consider the clearances to all of these combustibles before you actually connect your stove. When considering these clearances, also note the floor the stove will rest on. Depending on your floor material, you can either install your stove on it as it is, or you must use a floor protector.

If you use a close clearance connector pipe, it must be tested to UL standards and listed. Check the listing for your pipe for actual clearances. The diagrams in this manual represent typical installations, but are specific to the Simpson Dura-Vent DVL brand. Clearances cannot be reduced without the use of close clearance connector pipe and/or by protecting the surfaces per National Fire Protection Agency (NFPA) 211 standards.

NFPA 211 PROTECTED SURFACES

You can reduce the clearances to combustibles by using any NFPA approved wall protection system. Please refer to NFPA 211 for specifications and complete details. You can obtain this information directly from NFPA.

National Fire Protection Agency

Batterymarch Park
Quincy, MA 02269
1-800-344-3555 or 1-617-770-3000
www.nfpa.org

HEARTH REQUIREMENTS AND FLOOR PROTECTION

Install your stove on one of the following:

- ✎ A floor protector with an R-value of 0.8 or more purchased from your dealer. A floor protector is any noncombustible surface laid on the combustible floor underneath the stove that extends 16 inches (US) and 18 inches (CA) beyond the fuel door opening, and 8 inches (203 mm) beyond each edge of the fuel loading opening (US) or from the body of the stove (CA), and 8 inches to the rear. See figure 2 on page 9.

For horizontal chimney connector installations, the floor protection must be installed beneath the connector and 2" beyond each side. To determine the R-value a purchased floor protector, do one of the following:

- ✎ If the R-value is given, use that value.
- ✎ If a K-factor is given with a required thickness (T) in inches, use this formula: $R\text{-value} = 1/K \times T$
- ✎ If a C-factor is given, use the formula: $R\text{-value} = 1/C$

To determine the R-value of an alternate floor protector (the do it yourself kind):

- ✎ Use either the K-factor or the C-factor formula explained above to convert material specifications not expressed as R-values.
- ✎ For multiple layers of floor protectors, simply add the R-values of each layer to determine the overall R-value of the layers.

If the overall R-value of your setup is greater than the R-value required for the floor protector, and you meet or exceed the minimum required dimensions, then your setup is acceptable.

Floor protector requirements, measurements, and dimensions listed and shown are specified by ULC 627 and ULC 1482, or upon results from independent lab safety testing if more stringent.

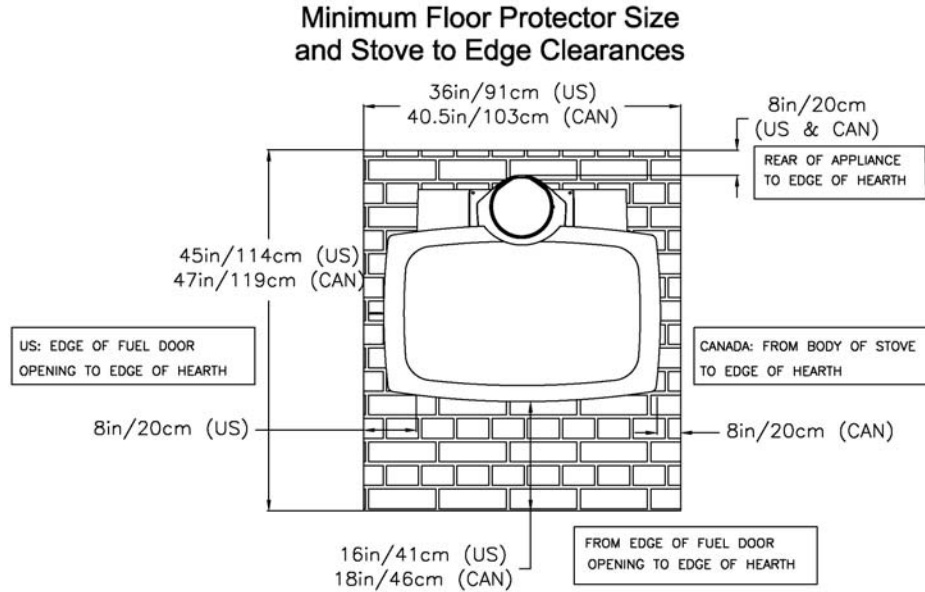

Figure 2 – 8371 Hearth Pad Dimensions

OUTSIDE AIR SUPPLY

An outside air source may be connected directly to this stove using an optional outside air kit (Hearthstone part #93-53700). The advantage of providing outside air directly to the stove is that the air used by the stove for combustion is taken from outside of the residence rather than from within the room where the stove is located. With outside air supplied directly to the stove, drafts within the room and air infiltration within the building are reduced. Use of the outside air kit may also improve stove performance in a particularly airtight house.

The outside air kit for this stove allows for the direct connection of the stove's air intake to a minimum 3" (76 mm) diameter duct (supplied by others) which leads to the outside of the house. When considering placement of the duct from the outside of the house to the hearth, keep in mind the need to avoid structural members of the house. The termination of the duct on the outside wall of the house should be located in such a manner so as to preclude the possibility of obstruction by snow, leaves or other material and should be screened against animals and insects.

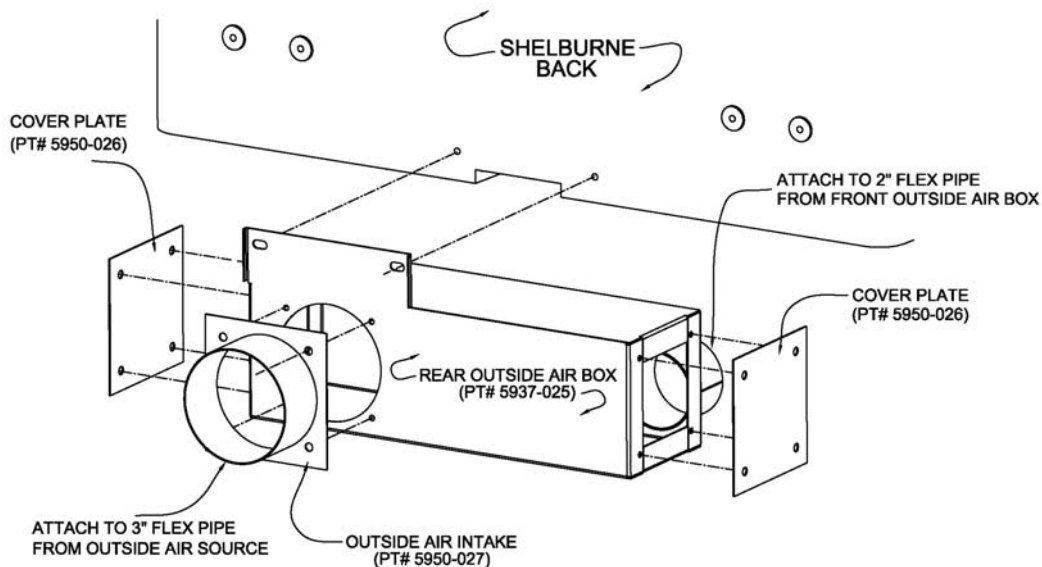
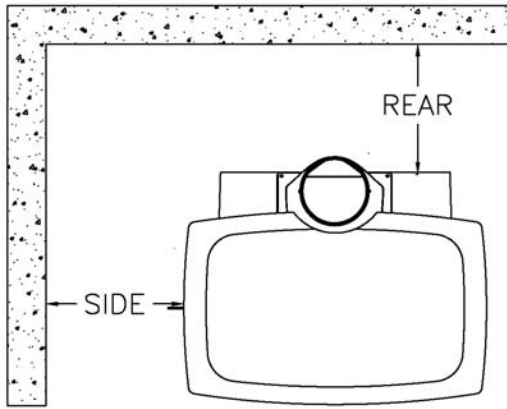

Figure 3 – Outside Air Adaptor Kit PN 93-53700

CLEARANCES TO COMBUSTIBLES

Please use this section to plan the layout for your stove. Consider clearance of *pipe* to combustibles and stove to combustibles. More specifics on installation follow.

You must follow minimum clearances for the Shelburne stove to combustibles such as walls and ceilings. You may reduce the general clearances if installing the stove near *Protected Surfaces* (see "CLEARANCES TO NFPA 211 PROTECTED SURFACES" in the following tables and diagrams).



PARALLEL

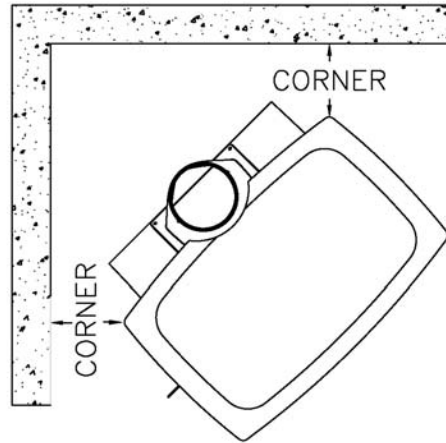

CORNER

Figure 4 – Freestanding Clearances

ALCOVE CLEARANCE TO COMBUSTIBLES

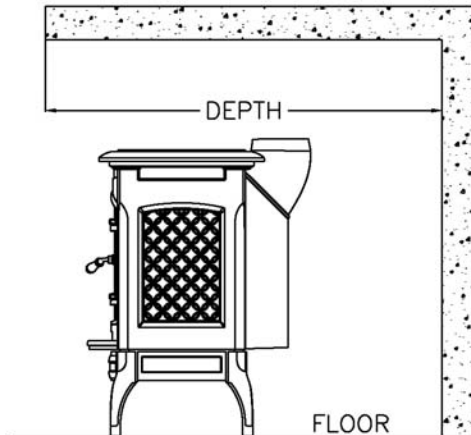

SIDE VIEW

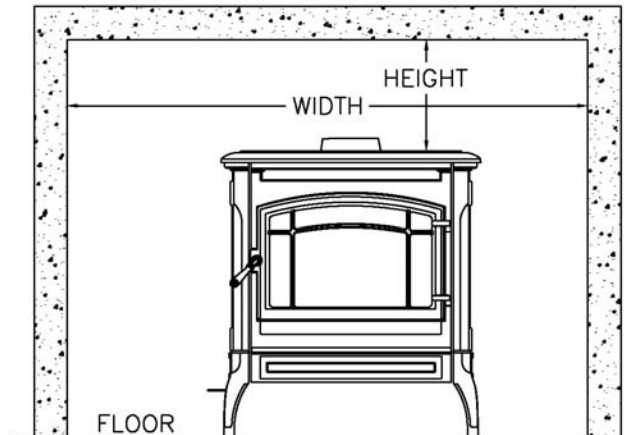

FRONT VIEW

Figure 5 – Alcove Installation Clearances

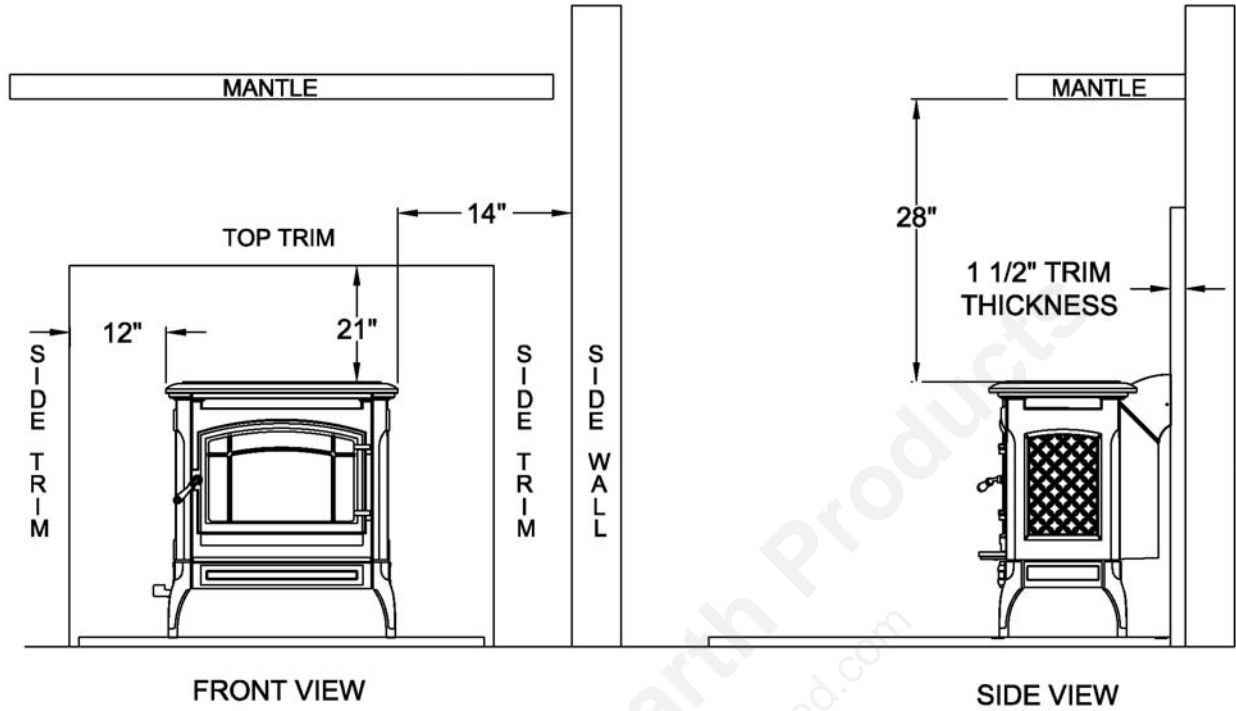

CLEARANCES APPLY WITH STOVE IN FIREPLACE ALSO

Figure 6 – Fireplace Installation Clearances

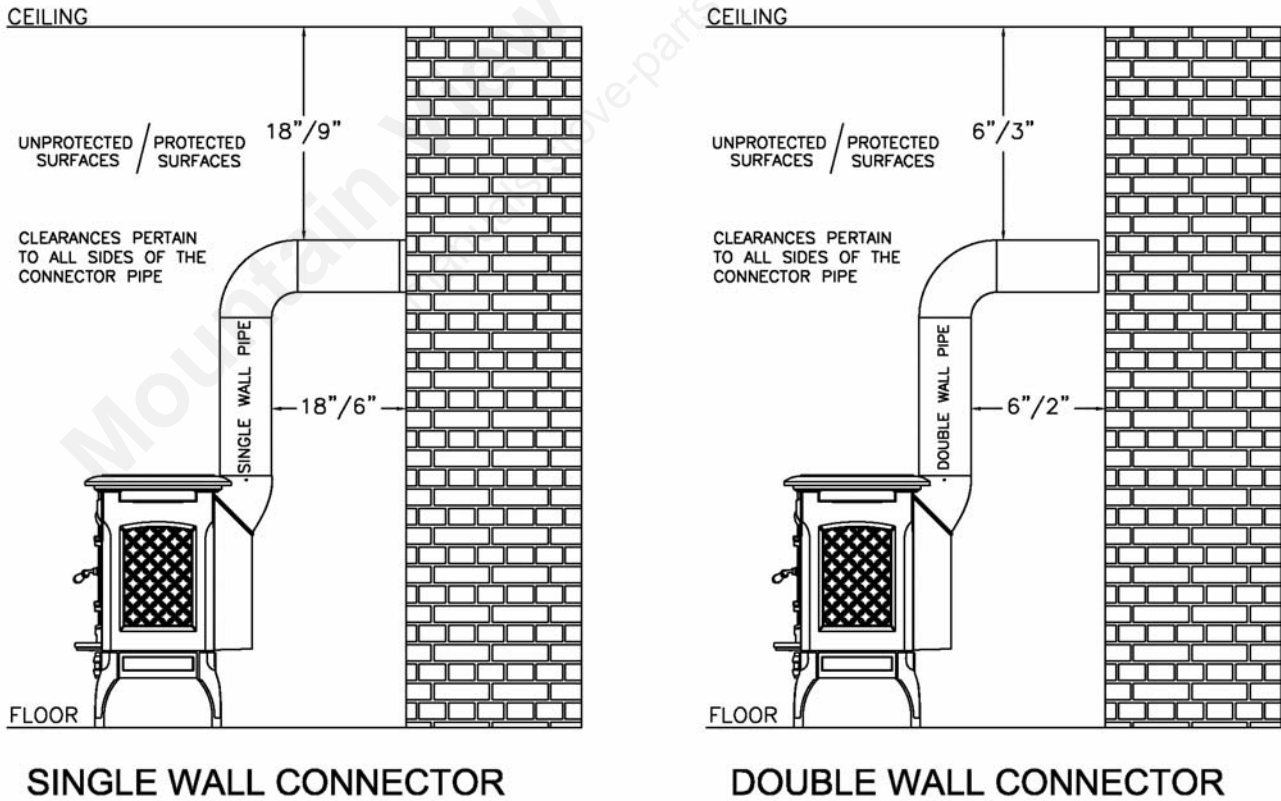

Figure 7 – Connector Clearances

FREESTANDING MINIMUM CLEARANCES

To Combustibles (from closest point of stove)

| Installation type | Unprotected Surfaces | | | Protected Surfaces (NFPA 211) | | |
|--|----------------------|--------------------|--------------------|-------------------------------|--------------------|-------------------|
| | Parallel | | Corner | Parallel | | Corner |
| | Side | Rear | | Side | Rear | |
| No stove heat shields & Single wall connector | 18 in. (460 mm) | 24 in. (610-mm) | 13 in. (330-mm) | 6 in. (150-mm) | 12 in. (305-mm) | 5 in. (130-mm) |
| Rear heat shield & Single wall connector | 21 in. (535 mm) | 18 in. (460-mm) | 13 in. (330-mm) | 6 in. (150-mm) | 9 in. (230-mm) | 3 in. (75-mm) |
| Rear heat shield & Double wall connector | 21 in. (535 mm) | 12 in. (305-mm) | 6 in. (150-mm) | 6 in. (150-mm) | 3 in. (75-mm) | 3 in. (75-mm) |

Allowable Alcove Dimensions

| Unprotected Surfaces | | | Protected Surfaces (NFPA 211) | | |
|----------------------|---------------------|---|-------------------------------|--------------------|---|
| Min. Width | Max. Depth | Min. Height (stove to ceiling above.) | Min. Width | Max. Depth | Min. Height (stove to ceiling above.) |
| 69 in. (1750-mm) | 42 in. (1065-mm) | 36 in. (915-mm) | 39 in. (990-mm) | 34-in. (865-mm) | 18 in. (460-mm) |

CLEARANCES FROM STOVEPIPE

Minimum Clearance to Combustibles (from Chimney Connector)

| Connector type | Unprotected Surfaces (vert.) | Protected Surfaces (NFPA 211) (vert.) |
|-----------------------------------|-------------------------------|--|
| No heat shields | 18-in. 460-mm | 6-in. 150-mm |
| Double wall connector | 6-in. 150-mm | 2-in. 50-mm |
| Connector type | Unprotected Surfaces (horiz.) | Protected Surfaces (NFPA 211) (horiz.) |
| Single wall connector pipe | 18-in. 460-mm | 9-in. 230-mm |
| Double wall connector pipe | 6-in. 150-mm | 3-in. 75-mm |

- 🔥 Single wall connector is 24 MSG or 25 MSG blued steel stovepipe.
- 🔥 Double wall connector (close clearance pipe) which must be used with a listed factory-built "Type HT" chimney and may also be used with a masonry chimney to reduce clearances, is available from several manufacturers, your dealer can help you choose. Some air insulated connector pipe models available are Simpson Dura Vent DVL and Metalbestos DS. Security, GSW and Ameritec also have acceptable close clearance connector pipe.
- 🔥 When used in a mobile home, a spark arrester is required. (See page 17)
- 🔥 Chimney connector shall not pass through floor or ceiling, nor any attic or roof space, closet or

similar concealed space. Where passage through a wall or partition of combustible construction is desired, the installation shall conform to NFPA 211 or CAN/CSA - B365.

- 🔥 It is very important to follow minimum clearances for chimney connectors to combustibles such as walls and ceilings when installing the stove near non-combustible surfaces. Typical chimney connector clearances are outlined below. The single wall clearances are generic; the Double wall clearances are for Simpson Dura Vent DVL, **CHECK THE SPECIFICATIONS FROM THE MANUFACTURER OF YOUR CONNECTOR.**

Venting

COMPONENTS OF A VENTING SYSTEM

🔥 **WARNING: DO NOT CONNECT THIS UNIT TO A CHIMNEY FLUE SERVING ANOTHER APPLIANCE**

The complete venting system consists of several components: chimney connector, wall thimble, wall pass-through, chimney, and liner. It is *absolutely necessary* that you install all of these components within the clearances to combustibles discussed earlier to install your stove safely.

To protect against the possibility of a house fire, you *must properly install and constantly maintain the venting system*. Upon inspection, immediately replace rusted, cracked, or broken components.

- 🔥 The *chimney connector* is the stovepipe from the woodstove to the chimney. The chimney connector stovepipe must be 6" (152 mm) diameter, 24 MSG or 25 MSG blued steel connector pipe. *Do not use aluminum or galvanized steel pipe* - they cannot withstand the extreme temperatures of a wood fire.
- 🔥 A *thimble* is a manufactured (or site-constructed) device installed in combustible walls through which the chimney connector passes to the chimney. It keeps the walls from igniting. You must use a wall thimble when installing a chimney connector through a combustible wall to the chimney.
- 🔥 A *wall pass-through* (or chimney support package) also keeps the walls from igniting. You must use one when connecting through a wall or ceiling to a prefabricated chimney.
- 🔥 Only install this stove to a *lined masonry chimney* or an approved high temperature *prefabricated residential* type building heating appliance chimney. *Do not* connect this stove to a chimney serving another appliance; you will compromise the safe operation of both the wood stove and the connected appliance.
- 🔥 **WARNING: DO NOT CONNECT THIS APPLIANCE TO ANY AIR DISTRIBUTION DUCT OR SYSTEM.**
- 🔥 A *liner* is the UL 1777 or ULC S635 (for factory built fireplace or masonry) chimney.

You must connect your stove to a chimney comparable to those recommended in this manual. *Do not use stovepipe as a chimney*. Use stovepipe for freestanding installations only to connect the stove to a proper chimney.

INSTALLING A VENTING SYSTEM

Stovepipe sections must be attached to the stove and to each other with the crimped end toward the stove. If creosote builds up, this allows the creosote to run into the stove and not the outside of the stovepipe and onto the stove.

Secure all joints, including attaching the stovepipe to the stove's flue collar, with three sheet metal screws. Install #10 x 1/2" (3 mm x 13 mm) sheet metal screws into the holes pre-drilled in the flue collar. Leaving off the screws can cause joints to separate from the vibrations that result during a creosote chimney fire.

You can simplify connecting stovepipe by using additional accessories such as telescoping pipes, slip-connectors or clean-out tees. These accessories ease the inspection of your chimney, as well as allow you to easily dismantle the stovepipe (without moving the stove) when you periodically inspect the stovepipe connection and chimney.

Install the stove as close as practical to the chimney, while maintaining all proper clearances. Install stovepipe that is as short and as straight as possible. Horizontal runs of stovepipe should always rise away from the stove a minimum of 1/4" per foot (21mm/m).

Long runs of stovepipe to increase heat dispersal are not recommended. Using longer lengths of stovepipe or more connecting elbows than necessary increase the chances of draft resistance and the accumulation of creosote buildup.

In general, you do not need to install a stovepipe damper with the Shelburne. Some installations, however, could benefit from a stovepipe damper, such as a tall chimney which can create a higher than normal draft. In such cases, a damper can help regulate the draft. The Shelburne requires a draft between 0.06" wc and 0.1" wc. For drafts above 0.1" wc, install a stovepipe damper.

Remember, the NFPA has recommended, minimum clearances for chimney connectors to combustibles such as walls and ceilings. Once the stove is installed at safe distances from these combustible surfaces, it is important to maintain these connector clearances for the remainder of the installation.

CONNECTING YOUR WOOD STOVE

You can install your Shelburne to a prefabricated metal chimney or a masonry chimney.

Connecting to a Prefabricated Metal Chimney

When connecting the Shelburne to a prefabricated metal chimney, you must follow, precisely, the manufacturer's installation instructions. Use only Type HT (2100 deg. F), prefabricated metal chimneys listed per UL 103 or ULC S629 standards.

🔥 WARNING: DO NOT CONNECT THE STOVE TO A CHIMNEY FLUE SERVING ANOTHER APPLIANCE.

Ensure the size of the chimney's flue is appropriate for the Shelburne. The Shelburne requires a 6" (152 mm) inside diameter flue for new installations. A 6" diameter flue provides adequate draft and performance. You can use an 8" (203 mm) diameter existing flue with a reducer. An oversized flue contributes to creosote accumulation. (In this case, bigger is NOT better.)

When purchasing a prefabricated chimney to install with your stove, ensure to also purchase from the same manufacturer the wall pass-through (or ceiling support package), "T" section package, fire-stops (when needed), insulation shield, roof flashing, chimney cap, and any other needed accessories. Follow the manufacturer's instructions when installing the chimney and accessories. In addition, be sure to maintain all manufacturers' recommendations for the proper clearances to the chimney.

Reversing the flue collar

In order to reverse the flue collar to vent the stove straight out the back, simply use a 7/16" wrench, or socket. Locate and remove the four bolts that mount the flue collar in place. Once all four bolts are removed, pull the collar away from the stove; inspect the gasket to ensure it is in place, and in working order. Rotate the collar 90 degrees, and replace the four bolts.

There are basically only two ways to install a prefabricated metal chimney:

- 🔥 An *interior* installation where the chimney passes inside the residence through the ceiling and roof.
- 🔥 An *exterior* installation where the chimney passes through the wall behind the stove then up the outside of the residence.

Whenever possible, choose an interior chimney. An interior chimney heats up more quickly and retains

its heat; thus promotes a better draft and discourages the formation of creosote. An exterior chimney does not benefit from the warmth of being surrounded by the building, so it typically operates at lower flue temperatures than an interior chimney. An exterior chimney's draft is not as strong and may experience increased creosote accumulation.

Connection to a Masonry Chimney

Consider two primary elements when connecting your stove to a masonry chimney: the chimney itself and the thimble where the stovepipe connects to the chimney. Use only Code approved masonry chimneys with a flue liner.

Before connecting to a masonry chimney, hire a professional to examine the chimney for cracks, loose mortar, and other signs of deterioration or blockage. If the chimney needs repairs, complete them before installing and using your stove. Do not install your stove until the chimney is safe for use.

Ensure the chimney's cleanout is complete and working properly. To avoid a loss of draft, the cleanout must close off completely. If the chimney is allowed to cool, your stove will perform poorly and creosote will build up in the chimney.

Ensure the size of the chimney's flue is appropriate for this stove, and that it is not too large. Use a masonry chimney with a 6" (152mm) diameter, or an 8" x 8" (203 mm x 203 mm) tile size for best results. An oversized flue will contribute to the accumulation of creosote.

Use the following checklist to ensure that your masonry chimney meets these minimum requirements:

Chimney wall construction:

- 🔥 Brick or modular block at least 4" (102 mm) thick.
- 🔥 A rubble or stone wall at least 12" (305 mm) thick.

Flue liner:

- 🔥 Minimum thickness of 5/8" (16 mm).
- 🔥 Installed with refractory mortar.
- 🔥 At least 1" (25 mm) air space.
- 🔥 An equivalent flue liner must be a listed chimney liner system meeting type HT requirements or other approved material.

Interior chimney requirements:

- 🔥 At least 2" (51 mm) clearance to combustible structure

- 🔥 Fire stops must be installed at the spaces where the chimney passes through floors and/or ceiling.
- 🔥 Insulation must be 2" (51 mm) from the chimney.

Exterior chimney requirements:

- 🔥 At least 1" (25 mm) clearance to combustible structure.

Chimney height requirements: (See Illustration)

- 🔥 At least 3 feet (0.9 m) higher than the highest part of the roof opening through which it passes.
- 🔥 At least 2 feet (0.6 m) higher than any part of the roof within 10 feet (3 m) measured horizontally from the top of the chimney.

This stove requires a minimum chimney height of 13 feet (4 m). The maximum allowable chimney height is 30 feet (9m).

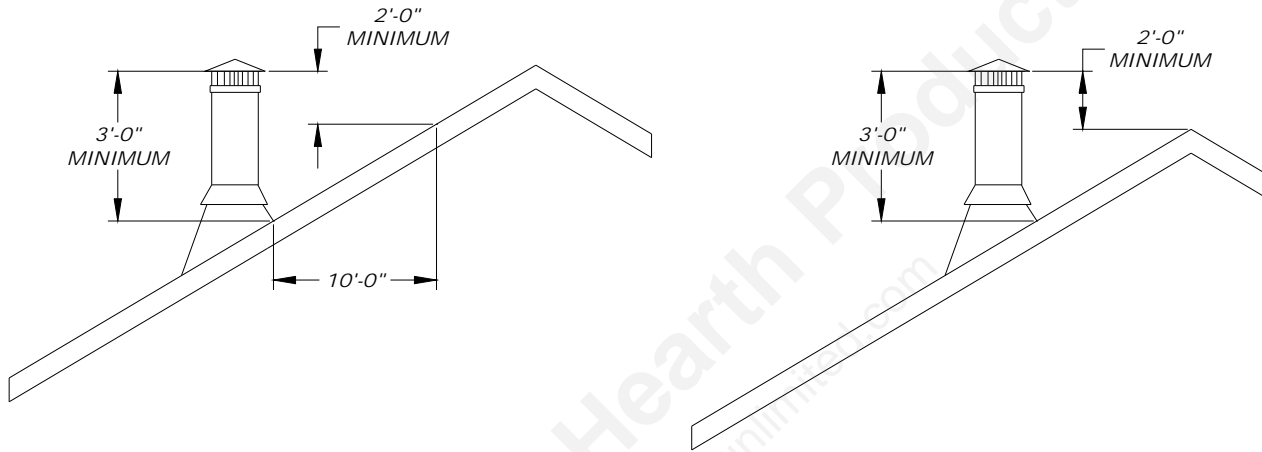
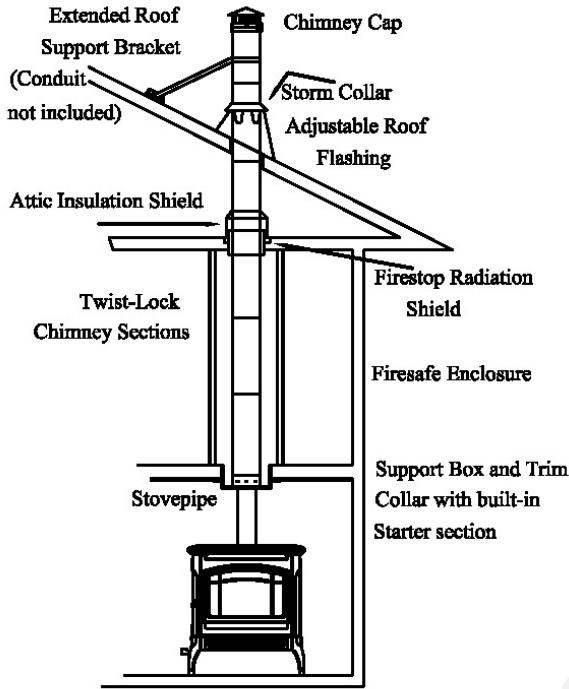
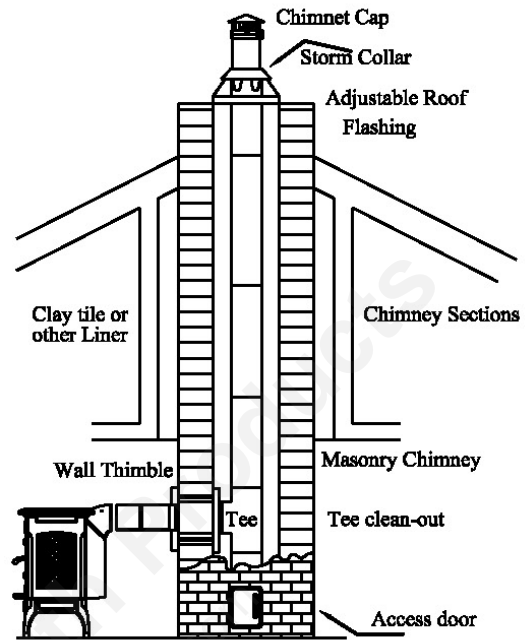

Figure 8 – Chimney Height Requirements



Two story house installation with attic.



Chimney pipe through Clay tile or other Lined Masonry Chimney

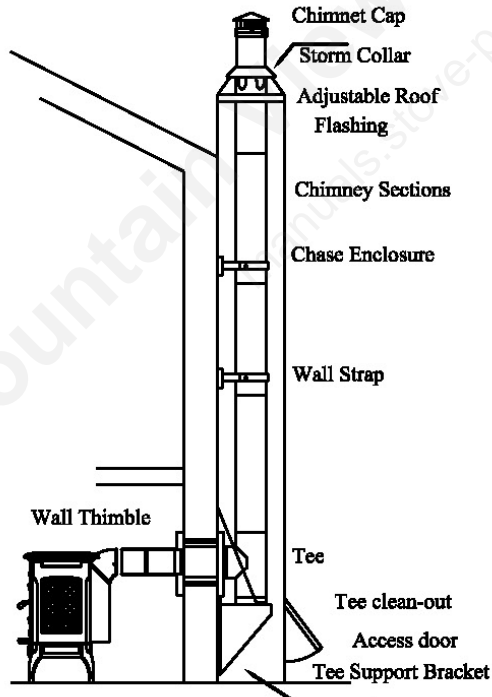

Chimney through outer wall with enclosed chase. Chimney is supported by Tee Support Bracket.

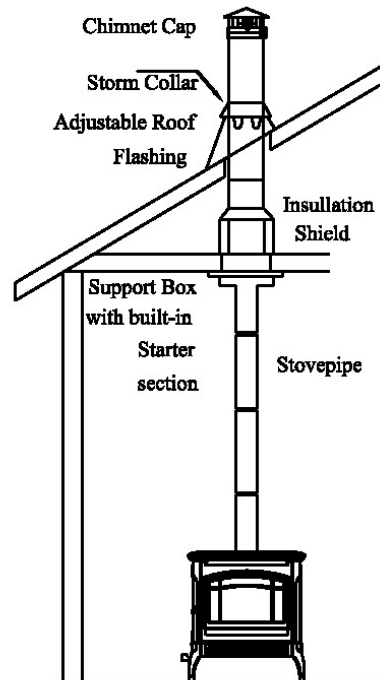

One story house installation with attic. Chimney is supported by Ceiling.

Figure 9 – Acceptable Chimney Configurations

MOBILE HOME INSTALLATIONS

Follow these special requirements for installing your stove in a mobile home.

- 🔥 Install the stove in accordance with 24 CFR, Part 3280 (HUD)
- 🔥 Permanently attach the stove to your mobile home's floor. Use the 3/8" holes in the base of each leg to bolt down the stove.
- 🔥 Install one of the following Dura-Vent Mobile Home Chimney & Connector Kits:

6DP-MH 6" Diameter S/N 9096N

7DP-MH 7" Diameter S/N 9196N

8DP-MH 8" Diameter S/N 9296N

Each kit includes:

Stainless spark arrester cap, storm collar,

Adjustable vented flashing – 0/12 – 6/12,
Two 24" Dura/Plus* chimney pipes, 24" support box with built-in starter section and trim.

- 🔥 (UL or ULC approved equipment is acceptable)
- 🔥 **WARNING: REMOVE THE CHIMNEY WHEN TRANSPORTING MOBILE HOME.**
- 🔥 **WARNING: DO NOT INSTALL IN A SLEEPING ROOM**
- 🔥 **CAUTION: MAINTAIN THE STRUCTURAL INTEGRITY OF THE MOBILE HOME WALLS, FLOOR, CEILING, AND ROOF WHILE YOUR STOVE IS INSTALLED AND IN USE.**

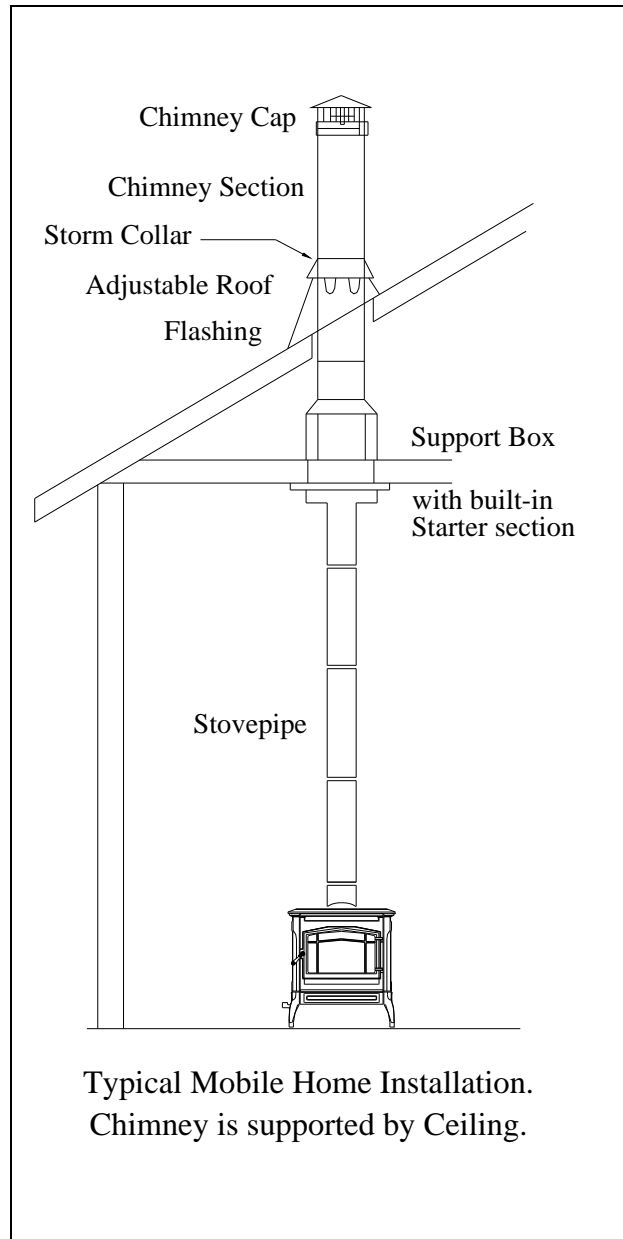

Figure 10

Operation

When your Shelburne is set in place, connected, and assembled, you are ready to light a fire. Hearthstone tests each woodstove before we ship, so you should be able to easily light your first fire. You may, however, have to make a few small adjustments to compensate for other factors particular to your installation.

🔥 **WARNING: HOT WHILE IN OPERATION. KEEP CHILDREN, CLOTHING AND FURNITURE AWAY. CONTACT MAY CAUSE SKIN BURNS.**

🔥 **WARNING! ENSURE YOU CLEAR AWAY ANY UNBURNED COALS OR DEBRIS BEHIND THE FUEL-LOADING DOOR BEFORE CLOSING IT. FAILURE TO DO SO MAY RESULT IN A CRACKED OR BROKEN GLASS. IF YOU HAVE A CRACK OR BREAK IN YOUR GLASS, PLEASE CONTACT YOUR DEALER IMMEDIATELY FOR REPLACEMENT.**

Please read this entire chapter before lighting your first fire. It explains the controls and features of your wood stove, how to choose firewood, and how to break-in your stove and use it on a daily basis.

CONTROLS AND FEATURES

Become familiar with the location and operation of your stove's controls and features and learn how to use them before lighting any fires. For your own safety, do not modify these features in any way.

FRONT DOOR HANDLE: The front door allows you to load wood into your stove. To open the door, lift the handle to the 10 o'clock position and pull the door. To latch the door lower the handle to the 7

o'clock position. Pull on the door to make sure it is properly latched.

PRIMARY AIR CONTROL: This feature is located on the lower left side of the stove. The primary air control allows you to regulate the amount of air entering the firebox. Generally speaking, the more air allowed into the firebox, the faster and hotter the rate of burn; conversely, less air creates a slower burn. Pull the lever toward the front of the stove to open the primary air control; push the lever toward the rear of the stove to close the primary air control.

ASH PAN: The ash pan is located under the ash lip behind the ash door. Open the ash door by pulling it towards you, then let it rotate downward to remove the ash pan. The ash pan collects the ash from a fire and allows you to conveniently remove the ash from your woodstove.

Open the ash grate and sift the ashes across the grate into the ash pan. Remove the ash pan by grabbing the handle and sliding it out smoothly and carefully. After you have disposed of the ashes, push the ash pan all the way into the stove tightly and close the ash door. If the ash door does not close completely, the ash pan is not properly inserted.

🔥 **DO NOT OPERATE THE STOVE UNLESS THE ASH PAN IS TIGHTLY INSERTED INTO THE STOVE. THIS COULD CAUSE OVER-FIRING AND DAMAGE THE STOVE.**

Remove ashes when the stove is cold. If the ash door or pan is warm, use protective fireplace gloves. Exercise extreme caution when handling, storing or disposing of ashes.

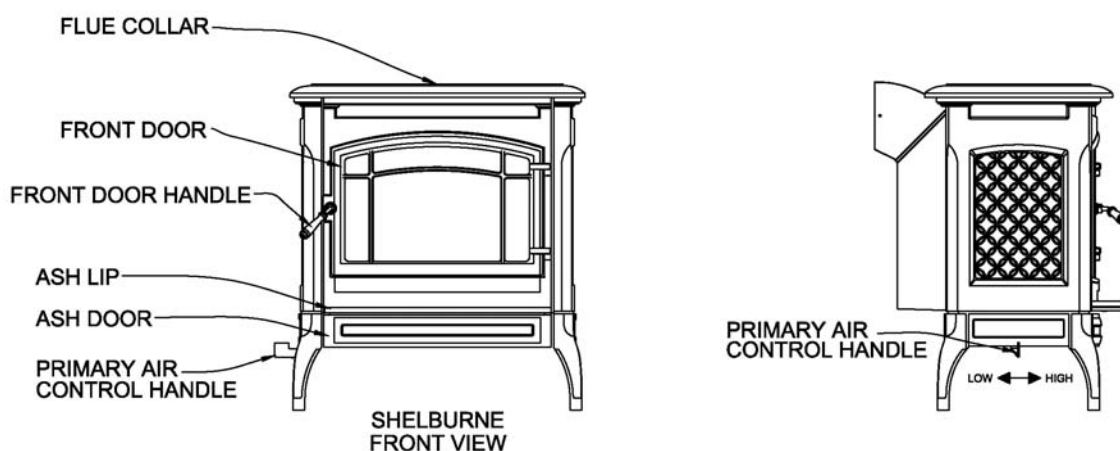

Figure 11 – Features and Controls

CHOOSING FIREWOOD

Your Shelburne Wood Heater is designed to only burn natural firewood - also known as cordwood.

CAUTION: DO NOT USE CHEMICALS OR FLAMMABLE FLUIDS SUCH AS GASOLINE, NAPHTHA, KEROSENE, CHARCOAL LIGHTER FLUID OR ENGINE OIL TO START A FIRE. DO NOT USE CHARCOAL, PELLETS, COAL, ARTIFICIAL LOGS OR ANY OTHER MATERIALS AS FUEL; THEY ARE NOT SAFE. DO NOT BURN GARBAGE.

The quality of your firewood directly affects heat output, duration of burn and performance of your stove. Softwoods generally burn hotter and faster, while hardwoods burn longer and produce better coals. Density and moisture content are two critical factors to consider when purchasing wood for your stove.

The following is a list of some wood species and their relative BTU (British Thermal Unit) content. The higher the BTU content, the longer the burn. Firewood with higher BTUs is generally ideal for a wood stove.

| Wood Heat Value: Sorted By Btu Content | | |
|---|-----------------|-------------------|
| Common Name | Lb/ cord | MBTU/ cord |
| High | | |
| Osage Orange (Hedge) | 4,728 | 32.9 |
| Hickory, Shagbark | 4,327 | 27.7 |
| Hop Hornbeam (Ironwood) | 4,267 | 27.3 |
| Beech, Blue (Ironwood) | 3,890 | 26.8 |
| Birch, Black | 3,890 | 26.8 |
| Locust, Black | 3,890 | 26.8 |
| Hickory, Bitternut | 3,832 | 26.7 |
| Locust, Honey | 3,832 | 26.7 |
| Apple | 4,100 | 26.5 |
| Mulberry | 3,712 | 25.8 |
| Oak, White | 4,012 | 25.7 |
| Medium High | | |
| Beech, European | 3,757 | 24 |
| Maple, Sugar | 3,757 | 24 |
| Oak, Red | 3,757 | 24 |
| Ash, White | 3,689 | 23.6 |
| Birch, Yellow | 3,689 | 23.6 |

| Medium | | |
|--------------------------------|-------|------|
| Juniper, Rocky Mtn | 3,150 | 21.8 |
| Elm, Red | 3,112 | 21.6 |
| Coffeetree, Kentucky | 3,112 | 21.6 |
| Hackberry | 3,247 | 20.8 |
| Tamarack | 3,247 | 20.8 |
| Birch, Gray | 3,179 | 20.3 |
| Birch, White (Paper) | 3,179 | 20.3 |
| Walnut, Black | 3,192 | 20.2 |
| Cherry | 3,120 | 20 |
| Ash, Green | 2,880 | 19.9 |
| Cherry, Black | 2,880 | 19.9 |
| Elm, American | 3,052 | 19.5 |
| Elm, White | 3,052 | 19.5 |
| Sycamore | 2,808 | 19.5 |
| Ash, Black | 2,992 | 19.1 |
| Maple, Red | 2,924 | 18.7 |
| Fir, Douglas | 2,900 | 18.1 |
| Medium Low | | |
| Boxelder | 2,797 | 17.9 |
| Alder, Red | 2,710 | 17.2 |
| Pine, Jack | 2,669 | 17.1 |
| Pine, Norway (Red Pine) | 2,669 | 17.1 |
| Pine, Pitch | 2,669 | 17.1 |
| Catalpa | 2,360 | 16.4 |
| Hemlock | 2,482 | 15.9 |
| Spruce, Black | 2,482 | 15.9 |
| Pine, Ponderosa | 2,380 | 15.2 |
| Low | | |
| Aspen, American | 2,290 | 14.7 |
| Butternut (Walnut, White) | 2,100 | 14.5 |
| Spruce | 2,100 | 14.5 |
| Willow | 2,100 | 14.5 |
| Fir, Balsam | 2,236 | 14.3 |
| Pine, White (Eastern, Western) | 2,236 | 14.3 |
| Fir, Concolor (White) | 2,104 | 14.1 |
| Basswood (Linden) | 2,108 | 13.8 |
| Buckeye, Ohio | 1,984 | 13.8 |
| Cottonwood | 2,108 | 13.5 |
| Cedar, White | 1,913 | 12.2 |

Wood moisture content plays a key role in the performance of your stove. Wood freshly cut from a living tree (green wood) contains a great deal of moisture. As you might expect, green wood burns poorly. You must season green wood before using it in your woodstove. To season green wood properly, split, stack, and allow it to air dry for a period of one year. Green wood may provide less than 2000 Btu per pound, whereas dry wood can provide up to 7000 Btu per pound.

Stack firewood on pallets or blocks to keep it off the ground; cover only the top of the stack. Plastic or tarps that cover the sides of the woodpile trap moisture and prevent the wood from drying. As for stacking, an old Vermonter said, "The spaces between the logs should be large enough for a mouse to get through, but not for the cat that's chasing it."

CAUTION: DO NOT STORE FIREWOOD WITHIN THE STOVE'S SPECIFIED CLEARANCES TO COMBUSTIBLE MATERIALS.

BUILDING A FIRE

Once you understand the controls of your wood stove and have chosen the appropriate firewood, you are ready to start a fire.

WARNING: NEVER USE GASOLINE, LANTERN FUEL, KEROSENE, CHARCOAL LIGHTER FLUID, OR SIMILAR LIQUIDS TO START OR 'FRESHEN UP' A FIRE IN THIS HEATER. KEEP ALL SUCH LIQUIDS WELL AWAY FROM THE HEATER WHILE IT IS IN USE.

CAUTION: STARTING A FIRE IN A COLD STOVE CAN CAUSE SIGNIFICANT CONDENSATION TO BRIEFLY FORM INSIDE THE FIREBOX AND FLUE. THIS LIQUID CAN LEAK FROM THE STOVE AND STAIN OR DAMAGE YOUR HEARTH IF NOT IMMEDIATELY REMOVED.

BREAKING IN YOUR WOOD STOVE

It is imperative that your stove is "broken in" slowly with at least one break-in fire. Cast iron must be "seasoned"; over-firing a new stove may cause castings to crack or may damage other stove parts. Also, any furnace cement must be cured slowly to ensure adequate sealing and bonding.

The firebrick in your firebox is intended to prevent thermal stress. Do not remove firebricks; replace them if cracked or missing.

When you light your first fires, the wood stove will emit some smoke and fumes. This is normal "off-gassing" of the paints and oils used when

manufacturing the wood stove. If you find it necessary, open a few windows to vent your room. The smoke and fumes will usually subside after 10 to 20 minutes of operation. The odor and smoke will end once the stove is "cured".

The first fires may produce other odors from impurities that exist in the area immediately surrounding the stove. Some of these impurities come from cleaning solvents, paint solvents, cigarettes, candle smoke, pet hair, dust, adhesives, a new carpet and textiles, etc. These odors will dissipate over time. You can alleviate these odors by opening a few windows or otherwise creating additional ventilation around your stove. If any odor persists, contact your dealer or an authorized service technician.

BUILDING A BREAK IN FIRE

1. Open the door and ensure the ash grate is in the closed position. Place five or six double sheets of tightly twisted newspaper in the center of the firebox. Arrange kindling in a crisscross pattern over the newspaper. Kindling should be approximately ten pieces, 1/2" (13 mm) in diameter and 10" to 18" (254 mm to 457 mm) long.
2. Fully open the primary air control by pulling the lever to the front of the stove.
3. Light the paper under the kindling. Leave the door slightly ajar momentarily until the kindling has started to burn and draft begins to pull.
4. Close the door and allow the fire to burn. Keep the door closed and ash pan tightly inserted while the stove is in use.
5. CAREFULLY MONITOR YOUR STOVE to maintain a steady, low-heat fire. Your break-in fire should make the stove warm but **not hot to the touch**. At most, add a few small chunks of wood to the fire to reach safe break-in temperatures.
6. Once the stove is warm but **not hot to the touch** close the primary air control and allow the fire to die out completely.
7. Let the stove return to room temperature.

Your patience will be rewarded by a properly seasoned stove.

NOTE: Creosote may build up quickly with the cool flue gas temperatures present during the break-in procedure. We recommend a visual inspection (and cleaning if necessary) of your stovepipe and chimney once the break-in procedure is completed.

NORMAL OPERATION

If your stove is not used continuously or has not been used in quite some time, follow the break-in procedure at least once to minimize the stress of a hot fire on a cold stove before proceeding with normal operation. We recommend one break-in fire at the start of each heating season. Prior to loading the stove, ensure the ash grate is closed and the ash pan is pushed fully into the stove. If the ash grate is open or the pan is loose, the stove will over-fire and be damaged.

BUILDING A FIRE FOR EVERYDAY USE

1. Open the door and place five or six double sheets of tightly twisted newspaper in the center of the firebox. Arrange kindling in a crisscross pattern over the newspaper. Kindling should be approximately ten pieces, 1/2" (13 mm) in diameter and 10" to 18" (254 to 457 mm) long.
2. Fully open the primary air control by pulling the lever toward the front of the stove.
3. Light the paper under the kindling. Leave the door slightly ajar momentarily until the kindling has started to burn and draft begins to pull.
4. Close the door and allow the fire to burn.
5. Once the kindling is burning, open the door and add logs, small at first, to build the fire up. Make sure to keep the logs away from the glass in front in order for the air-wash system to work properly. Otherwise, keep the door and ash drawer closed while the stove is in use.
6. Once the fire is burning well, use the primary air control to regulate the desired rate of burn. Pulling the lever toward the front of the stove opens the PRIMARY AIR CONTROL for a high rate of burn or pushing it toward the rear of the stove for a low rate of burn.

 **Note:** When opening the door to reload or rearrange logs, it is advisable to open the door just a crack, pause for a moment, then open the door completely. This procedure will allow the firebox to clear of smoke before the door is opened fully. Also, reloading on a bed of hot, red coals reduces smoking time (emissions) and will bring fresh fuel up to a high temperature rapidly.

BURN RATE

HIGH BURN: Center top surface temperature 500° to a maximum of 600°F. Fully load the firebox with wood on a bed of hot coals or on an actively flaming

fire and fully open the primary air control. A high burn rate is recommended once or twice a day to fully heat the stovepipe and chimney, which will help minimize creosote accumulation.

MEDIUM BURN: Center top surface temperature 350° - 500°F. Set the primary air control to a mid-range setting appropriate for the heating needs of the area being heated. A medium burn rate should be the typical setting and is preferable if the stove is to be left unattended.

LOW BURN: Center top surface temperature less than 350°F. Close the primary air control for a low burn rate. A low burn rate over extended periods of time is not advisable as it may promote the accumulation of creosote. The venting system should be inspected frequently if low burn rates are maintained consistently.

OVER-FIRE CAUTION

Over-firing means the stove is operating at temperatures above the high burn recommended temperatures outlined in the *BURN RATE* section. Carefully avoid over-firing since it will cause damage to the stove. Symptoms of over-firing include blistered enamel, warped parts, short burn times, a roaring sound in the stove or stovepipe, and discoloration of the stovepipe.

Over-firing can be caused by excessive draft, inappropriate fuel, and operator error. Correct an over-fire situation as follows:

EXCESSIVE DRAFT: Contact your dealer to have a draft reading taken. Any draft in excess of 0.1 wc requires a damper in the stovepipe. Some installations may require more than one damper.

INAPPROPRIATE FUEL: Do not burn coal, kiln dried lumber, wax logs or anything other than natural cordwood.

OPERATOR ERROR: Ensure all the gaskets are in good condition. Replace worn out or compressed gaskets. Do not burn the stove with the front door opened or the ash pan not fully inserted.

Monitoring the temperature is the best way to determine that the stove is over-firing. If you suspect that your stove is over-firing, contact your dealer immediately. Damage done by over-firing is not covered by your warranty. Results of over-firing can include: warped or burned out internal parts, cracked stones, discolored or warped external parts, and damaged enamel.

 **NOTE: ANY SYMPTOMS OF OVER-FIRING WILL VOID YOUR WARRANTY!!**

REMOVAL AND DISPOSAL OF ASHES

Ashes should be removed only when the stove is cold. Use protective fireplace gloves when the pan is warm. Exercise extreme caution when handling, storing or disposing of ashes.

To remove ashes from the firebox, sift the ashes across the opened ash grate using a poker or other suitable implement. Remove the ashes by pulling the handle on the ash pan and sliding it carefully out. Dump the ashes as described below. Re-insert the ash pan by pushing it in all the way. Ensure that the ash pan is pushed firmly into place to seat the gasket. Alternately, the ashes can be removed with a shovel through the front door.

Dump ashes from the ash drawer into a metal container with a tight fitting lid. Do not place any

other items or trash into the metal container. Replace the container's lid and allow the ashes to cool. Do not place the ash disposal container on a combustible surface or vinyl flooring, as the container will be **hot!**

Pending disposal, place the closed ash container on a noncombustible floor or on the ground, well away from all combustible materials. Retain ashes in the closed container until all cinders have thoroughly cooled.

 **NEVER** Place ashes in wooden or plastic containers, or in paper or plastic bags, no matter how long the fire has been out. Coals within a bed of ashes can remain hot for several days once removed from the firebox.

Maintenance

MONITORING STOVE TEMPERATURES

Monitor the stove temperatures with a stove thermometer (available from your dealer) placed on the top center of the stove. The thermometer could read as high as 600°F (427°C) on high burn and 300-400°F (149°-204°C) on low burn.

Do not over-fire the stove. (refer to page 21).

🔥 NOTE: ANY SYMPTOMS OF OVER-FIRING WILL VOID YOUR WARRANTY!

CREOSOTE FORMATION & REMOVAL

Wood burned slowly at low temperatures produces tar and other organic vapors, which combine with expelled moisture to form creosote. These creosote vapors condense in the relatively cool chimney flue of a slow-burning fire. As a result, creosote residue accumulates on the flue lining. When ignited, this creosote makes an extremely hot fire, which may damage the chimney or even destroy the house. When burning wood, inspect the chimney connector and chimney at least once every two months during the heating season to determine if there is a creosote buildup.

If such a creosote build-up occurs, inspect the stovepipe connector and chimney more often, at least monthly during the heating season to monitor the accumulation. Whenever a creosote residue greater than 1/4" (6 mm) accumulates, remove it to reduce the risk of a chimney fire.

Prevention

Burn the stove with the primary air control fully open for 35 - 45 minutes daily to burn out creosote deposits from within the stove and the venting system.

After reloading with wood, burn the stove with the primary air control fully open for 15 to 20 minutes. This manner of operation ensures early engagement of the secondary combustion system that minimizes creosote buildup in the chimney.

If your glass always remains dirty, your operating temperatures are consistently too low or your wood is wet; therefore, there is a higher risk of creosote buildup.

Inspect the venting system at the stove connection *and* at the chimney top. Cooler surfaces tend to build creosote deposits faster, so it is important to check the chimney at the top (where it is coolest) as well as from the bottom near the stove.

Cleaning

Remove accumulated creosote with a cleaning brush specifically designed for the type of chimney in use. We recommend you use a certified chimney sweep to perform this service. Contact your dealer for the name of a certified chimney sweep in your area (your dealer may be a certified sweep!).

We also recommended that before each heating season you have the entire system professionally inspected, cleaned and repaired, if necessary.

GASKETS

Replace gasket material every two to three seasons, depending on stove use, or whenever it becomes deteriorated or loose. If the front or ash door seals leak, new gaskets will ensure a tight seal and improved stove performance.

We recommend you only use Hearthstone replacement gaskets when you need to replace your door or other gaskets. Contact your dealer for gasket kit # 93-58700 that includes instructions, and all the gaskets needed for your stove.

To replace door gaskets, first remove the old gaskets. Clean all gasket channels with a wire brush or other suitable tool. Sparingly apply gasket cement to the door channels and push the new gasket into place without stretching the gasket material. Too much glue will saturate the gasket – this will harden the gasket, and reduce its performance. Shut the door immediately to fully press the gasket into place and assure a positive seal.

Do not use gasket glue on the glass gasket as the liquid glue could run onto the glass.

Gasket kit # 93-58700 contains the following items:

8' (244 cm) Length, 1/4" (6.4 mm) Adhesive Backed, Black Rope

9' (275 cm) Length, 3/8" (9.5 mm) Diameter, Medium Density, Adhesive Backed, Black Rope

6 each, Gasket Pads for the Glass Clips

Gasket Glue

GLASS

Do not operate the stove with a broken door glass. Do not abuse the front door by striking or slamming.

When necessary, clean the glass with low alkaline content commercial stove glass cleaners, which are available from your local dealer. Never attempt to clean the glass while the fire is burning or the glass is hot. Following the instructions provided with the cleaner will remove most deposits. To clean heavier deposits, open the door and lift it straight up and off the stove with the hinge pins remaining in the door (take care to save hinge pins and any spacer washers for reuse). Lay the door face down on a workbench or table. Apply the cleaner to the glass and allow it to soak for a few minutes. Laying the door flat will allow the cleaner to penetrate rather than run off the surface of the glass. Wipe the cleaner off with a soft cloth.

 **Important:** scratching or etching the glass will weaken the integrity of the glass. Do not use a razor blade, steel wool, or any other abrasive material to clean the glass. Use low alkaline content cleaners only.

The front door glass is a high temperature ceramic, shock-resistant glass, made specifically for use in woodstoves. Do not use any replacement glass other than the ceramic glass manufactured and supplied for use in this woodstove. Replacement glass is available through your local dealer.

 **Replace the door glass immediately if broken. Contact your local dealer for replacement glass kit (PN: 93-58705), which is accompanied with instructions and everything needed for the repair. If you replace the glass yourself, wear work gloves and safety glasses.**

The procedure for glass replacement is as follows:

1. Remove the door by lifting it straight up off the hinges with the hinge pins remaining in the door.
2. Place the door face down on a flat, smooth surface.
3. Apply penetrating oil to the screws in the glass retention clips. Let soak, and then remove the glass clips from the door.
4. Carefully lift the damaged glass from the door and discard.
5. Remove the old rope gasket, and ensure the channel is clean.
6. Place the new adhesive backed rope gasket evenly into the channel.
7. Place the glass provided in the replacement kit onto the door.
8. Re-install the glass clips with the new pads provided in the kit.
9. Re-install the door.

CAST IRON

Exterior cast iron parts are either painted with black, high-temperature stove paint or porcelainized with an enamel finish in various colors.

Use black, high-temperature stove paint (satin black by Stovebright) to touch up and maintain the original appearance of painted cast iron. Use a damp sponge to wipe clean. Dry the cast iron thoroughly to prevent rusting.

Clean enamel castings with a standard glass cleaner. With time and use, a very fine, subtle network of crazed lines may appear seemingly beneath the surface of the enamel. Crazing is a natural predictable process and does not represent a flaw.

Troubleshooting

Virtually all woodstove operators experience basic common problems at one time or another. Most are correctable and generally require only a minor adjustment of the stove, installation, or operating technique. In cases where weather conditions dramatically affect stove performance, the problems are typically temporary and solve themselves once the weather changes.

If you question whether or not your stove is producing adequate heat, the best way to troubleshoot the problem is to monitor the temperature of the stack (single wall connector pipe). A stack temperature of at least 400 degrees F (200 degree C) indicates the stove is heating sufficiently. A 350 to 600 degree F center top surface temperature confirms your Shelburne is supplying sufficient heat to the room. Keep in mind that your house itself will regulate room/house temperatures. How well the walls, floors and ceilings are insulated, the number and size of glass windows, the tightness of outside doors, and the construction or style of your house (vaulted ceilings or other open spaces which collect large percentages of heat) all are determining factors of room temperature.

Your stove's performance is also dependant on its installation. One common cause of poor performance is an oversized chimney flue. Oversized chimney flues result in decreased pressure, which prevents the smoke from rising out the chimney. Oversized flues are also more difficult to heat effectively, especially when burning a high efficiency stove. Cool flue temperatures inhibit the establishment of a strong draft (and encourage the accumulation of creosote). The lack of a strong draft will cause the fire to die down and may even force the smoke to pour into the room.

If your chimney is the proper size and a strong draft is not easily established, there is the possibility of the chimney being too cold. Again, hot chimneys promote a stronger draft.

Other draft guidelines are as follows:

AN "AIRTIGHT" HOUSE: If your home is super-insulated or especially well sealed, the (infiltration)

air supply to the interior of the house may be inadequate. This phenomenon of air starvation within the building can be exacerbated if exhaust fans, such as clothes dryers, bathroom fans or cook-stove exhaust fans, are in operation within the home. Outfitting your stove with the optional outside air supply adaptor connected to an air duct which leads to the outside of the building should correct this problem.

TALL TREES OR BUILDINGS: These obstructions, when located in proximity to the top of the chimney can cause chronic or occasional downdrafts. When selecting a site for a new chimney, take care to consider the placement of other objects in the vicinity of the proposed chimney location.

WIND VELOCITY: Generally, the stronger and steadier a wind, the stronger (better) the draft. However, "gusty" wind conditions may cause erratic downdrafts.

BAROMETRIC PRESSURE: Chimney drafts are typically sluggish on balmy, wet or muggy days. This is a weather-related phenomenon, which generally is self-correcting as the weather changes.

BRISKNESS OF FIRE: The hotter the fire in your stove, the hotter your chimney and, therefore, the stronger the draft.

BREAKS IN THE VENTING SYSTEM: An unsealed clean-out door at the bottom of the chimney, leaky stovepipe joints, a poor stovepipe-to-thimble connection, or a leaky chimney may cause inadequate draft.

SEASONAL FACTORS: Early fall and late spring are generally difficult seasons in which to establish proper drafts. The colder the outside air (relative to room temperatures), the stronger the draft.

Operating the Stove

There are days when a draft is not easily established. As outlined above, seasonal factors or a cold chimney may be the cause. Try starting the fire by using small kindling and fuel to obtain a quick, hot fire. Tend the fire frequently with small fuel until the chimney is hot and the draft is well established.

TROUBLESHOOTING GUIDE

| PROBLEM | POSSIBLE CAUSE | SOLUTIONS |
|--------------------------------|--|---|
| STOVE SMOKES | <p>Operating Technique</p> <p>Cold Chimney Blocked Chimney</p> <p>Oversized Chimney Undersized Chimney Chimney Too Short Air Infiltration Into The Chimney More Than One Appliance Connected to the Flue</p> | <p>Fully open the primary air control one minute before opening doors.</p> <p>Preheat the chimney when first starting a fire.</p> <p>Examine the chimney and stovepipe for blockage or creosote accumulations.</p> <p>Reline the chimney to the appropriate diameter</p> <p>Install a draft inducer or replace the chimney.</p> <p>Lengthen the chimney.</p> <p>Seal chimney connections and openings in clean-out doors.</p> <p>Disconnect all other appliances and seal openings.</p> |
| BACK-PUFFING OR GAS EXPLOSIONS | <p>Operating Technique</p> <p>Extra Low Burn Rate Chimney Down-draft Excessive Ash Build-up</p> | <p>Fully open the primary air control one minute before opening the door and keep it fully open for a few minutes after reloading.</p> <p>Burn the stove at a higher burn rate.</p> <p>Install a chimney cap.</p> <p>Empty ash pan more frequently.</p> |
| UNCONTROLLED OR SHORT BURN | <p>Unsealed or Open Door</p> <p>Excessive Draft</p> <p>Deteriorated Cement Seals</p> <p>Extra Long Chimney Oversized Chimney High Winds or Hilltop Location: Excessive Draft</p> | <p>Close the door tightly or replace the gaskets.</p> <p>Check the installation. Operate at LOW BURN. Install stovepipe damper.</p> <p>Reseal the stove with furnace cement.</p> <p>Shorten the chimney. Install stovepipe damper.</p> <p>Reline the chimney to the proper diameter.</p> <p>Install a chimney cap.</p> <p>Draft in excess of 0.1 wc should be corrected with a stovepipe damper</p> |
| INSUFFICIENT HEAT | <p>Poor Quality or Green Wood Low Burn Rate Air Insulated Chimney</p> <p>Cold Exterior Chimney Leaky Stovepipe or Chimney Too Much Heat Loss From House</p> | <p>Use only air-dried wood, preferably dried <u>at least</u> one year.</p> <p>Operate the stove at a higher burn rate.</p> <p>Replace with a pre-fabricated insulated chimney system or a properly sized masonry chimney.</p> <p>Reline or insulate the chimney.</p> <p>Check the installation.</p> <p>Caulk windows, seal openings in home.</p> |
| BLISTERING OF ENAMEL CASTING | <p>Operating Technique</p> <p>Excessive Draft</p> | <p>Do not over-fire the stove. Monitor stove temperatures. Use seasoned wood only.</p> <p>Check the DRAFT. (See page 10) A damper may be required. Operate the stove at a LOW BURN range.</p> |

Replacement Parts & Optional Accessories

| PART NUMBER: | DESCRIPTION: | PART NUMBER: | DESCRIPTION: |
|------------------------------------|-------------------------------|-----------------------------|--------------------------------|
| CASTINGS | | MISCELLANEOUS | |
| 2310-584 | FLUE COLLAR ADAPTOR (Matte) | 93-58705 | GLASS ASSEMBLY |
| 2310-700 | BOTTOM (Matte) | 3060-425 | FIRE BRICK 4-1/4" x 8-1/2" |
| 2310-710 | ASH GRATE | 3060-426 | FIRE BRICK 4-1/2" x 9" |
| 2310-725 | REAR PANEL (Matte) | 3060-430 | FIRE BRICK 4" x 9" |
| 2310-731 | LEFT SIDE (Matte) | 93-58700 | GASKET KIT |
| 2310-736 | RIGHT SIDE (Matte) | 90-71100 | DOOR HANDLE KIT |
| 2310-746 | FRONT (Matte) | 93-73701 | FRONT DOOR LATCH KIT |
| 2310-715 | ASH DOOR (Matte) | 3120-370 | BOARD: LOWER CERAMIC |
| 2310-720 | ASH LIP (Matte) | 3120-371 | BOARD: UPPER CERAMIC |
| 2310-755 | TOP CASTING (Matte) | | |
| 2310-760 | FLUE COLLAR (Matte) | | |
| 2310-750 | FRONT DOOR (Matte) | | |
| 2310-740 | PRIMARY AIR PLENUM | | |
| 2310-742 | SECONDARY AIR RISER | | |
| 2310-754 | SECONDARY AIR PLENUM – TOP | | |
| 2310-752 | SECONDARY AIR PLENUM – BOTTOM | | |
| STEEL SET | | OPTIONAL ACCESSORIES | |
| 5370-031 | PRIMARY AIR CONTROL | 90-57000 | BLOWER ASSEMBLY |
| 5370-040 | PRIMARY AIR CONTROL HANDLE | 93-53700 | OUTSIDE AIR ADAPTER KIT |
| 5370-012 | BOX: ASH PAN | 93-68700 | REAR HEATSHIELD KIT |
| 5370-052 | ASH DOOR BRACKET, LEFT | | |
| 5370-062 | ASH DOOR BRACKET, RIGHT | | |
| 5370-065 | RETAINER, REAR FIREBRICK | | |
| 5370-066 | RETAINER, SIDE FIREBRICK | | |
| 5370-068 | CLIP, GLASS | | |
| 5370-070 | FRONT DOOR STRIKER PLATE | | |
| 5370-112 | THROAT BAFFLE, SS | | |
| 5570-030 | CABLE: LABEL, 1/16" X 12" | | |
| 5370-005 | HEATSHIELD, BOTTOM | | |
| 5370-022 | PAN: ASH | | |
| 5370-091 | PIPE: AIR, SECONDARY #1 | | |
| 5370-092 | PIPE: AIR, SECONDARY #2 | | |
| 5370-093 | PIPE: AIR, SECONDARY #3 | | |
| 5370-100 | SUPPORT: BAFFLE | | |
| 5370-110 | HEATSHIELD: TOP, SS | | |
| | | | |
| | | | |
| | | | |
| Specify color if finish is enamel. | | | 8371 – 4/18 SAP Summarized BOM |

WARRANTY REGISTRATION

The Original Purchaser can complete their warranty registration on our website at www.hearthstonestoves.com, or send a completed and signed Warranty Registration Form, which is enclosed in the Stove Information packet, to the following address:

Hearthstone Quality Home Heating Products, Inc.
Warranty Department
317 Stafford Avenue
Morrisville, VT 05661
inquiry@hearthstonestoves.com

👉 **NOTE: SENDING IN THE SIGNED WARRANTY REGISTRATION FORM IS *NOT REQUIRED* AS A CONDITION OF WARRANTY COVERAGE OR HEARTHSTONE'S PERFORMANCE.**

Mountain View Hearth Products
manuals.stove-parts-unlimited.com