

Owner's Manual

Care and Operation

Pour demander un exemplaire en français de ce Manuel du propriétaire, visitez www.heatnglo.com/translations.

INSTALLER: Leave this manual with party responsible for use and operation.

OWNER: Retain this manual for future reference.

NOTICE: DO NOT discard this manual!

HEAT & GLO™

Model(s):
NORTHSTAR-BK
NORTHSTAR-GT
NORTHSTAR-NT

Tested and Listed by  Portland Oregon USA
C US
OMNI-Test Laboratories, Inc.

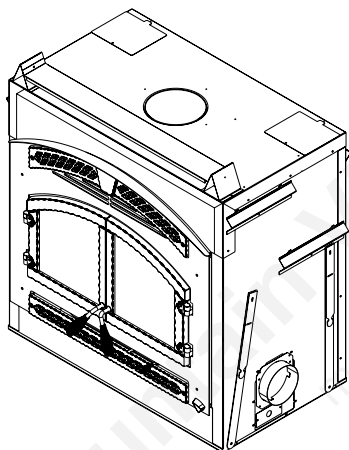

**EPA CERTIFIED WOODBURNING
FIREPLACE**

⚠ WARNING: If the information in these instructions is not followed exactly, a fire or explosion may result causing property damage, personal injury, or death.

- **DO NOT** store or use gasoline or other flammable vapors and liquids in the vicinity of this or any other appliance.
- **DO NOT** overfire. Overfiring will void your warranty.
- Comply with all minimum clearances to combustibles as specified. Failure to comply may cause house fire.

⚠ WARNING



HOT SURFACES!

Glass and other surfaces are hot during operation AND cool down.

Hot glass will cause burns.

- **DO NOT** touch glass until it is cooled
 - **NEVER** allow children to touch glass
 - Keep children away
 - **CAREFULLY SUPERVISE** children in same room as fireplace.
 - Alert children and adults to hazards of high temperatures.
- High temperatures may ignite clothing or other flammable materials.**
- Keep clothing, furniture, draperies and other flammable materials away.

myhht
FACTORY
training

Installation and service of this appliance should be performed by qualified personnel. Hearth & Home Technologies recommends HHT Factory Trained or NFI certified professionals.



⚠ WARNING



Fire Risk.

For use with solid wood fuel only.
Other fuels may overfire and generate poisonous gases (i.e. carbon monoxide).

Safety Alert Key:

- **DANGER!** Indicates a hazardous situation which, if not avoided will result in death or serious injury.
- **WARNING!** Indicates a hazardous situation which, if not avoided could result in death or serious injury.
- **CAUTION!** Indicates a hazardous situation which, if not avoided, could result in minor or moderate injury.
- **NOTICE:** Indicates practices which may cause damage to the fireplace or to property.

Table of Contents

1 Welcome		4 Maintenance and Service	
A. Congratulations	3	A. Maintenance Tasks-Homeowners	16
B. LIMITED LIFETIME WARRANTY	4	1. Chimney Inspection	16
2 Product Specific Information		2. Creosote (Chimney) Cleaning	17
▶ A. Fireplace Certification	6	3. Care and Cleaning of Plated Surfaces	18
B. BTU & Efficiency Specifications	6	4. Glass Doors	18
C. Mobile Home Approved	6	5. Glass Cleaning	18
D. Glass Specifications	6	6. Door Gasket	18
3 Important Safety and Operating Information		7. Ash Removal	18
A. Fireplace Safety	7	8. Baffle and Blanket	18
1. Clear Space	7	9. Firebrick	18
2. Firebrick	8	B. Replacement Maintenance	19
3. Baffle and Blanket	8	1. Glass Replacement	19
4. Over-Firing Your Fireplace	8	2. Tighten or Adjust Door Latch	19
5. Chimney Fire	8	3. Firebrick Replacement	20
B. General Operating Parts	9	4. Baffle Removal and Installation	21
1. Automatic Combustion Control (ACC)	10	5. Fan Replacement	21
2. ACC Override	10	6. Timer Assembly Replacement	22
3. Outside Air	11	7. Timer Removal & Replacement	24
4. Glass Doors	12	5 Troubleshooting	
5. Convection Fan Operation	12	A. FAQs	26
C. Fuel	12	B. Troubleshooting Table	28
1. Hardwood vs. Softwood	12	6 Reference Materials	
2. Moisture content	13	▶ A. Service Parts	29
3. Seasoning	13	C. Contact Information	36
4. Storing Wood	13		
5. Burning Process	14		
6. Dirty Glass	14		
7. Creosote Formation	14		
8. Opacity	14		
D. First Fire	14		
E. Lighting Instructions	15		
F. Heat Management	15		

1 Welcome

Read this manual before installing or operating this fireplace.
Please retain this owner's manual for future references.

A. Congratulations

Congratulations on selecting a Heat & Glo wood burning fireplace. The Heat & Glo fireplace you have selected is designed to provide the utmost in safety, reliability, and efficiency.

As the owner of a new fireplace, you'll want to read and carefully follow all of the instructions contained in this Owner's Manual. Pay special attention to all Cautions and Warnings.

This Owner's Manual should be retained for future reference. We suggest that you keep it with your other important documents and product manuals.

Your new Heat & Glo wood burning fireplace will give you years of durable use and trouble-free enjoyment. Welcome to the Heat & Glo family of fireplace products!

Heat & Glo is a registered trademark of Hearth & Home Technologies.

Local Dealer Information

DEALER: Fill in your name, address, phone and email information here and fireplace information below.

Dealer Name: _____
 Address: _____

 Phone: _____
 Email: _____

Fireplace Information:

Brand: _____ Model Name: _____
 Serial Number: _____ Date Installed: _____

Listing Label Information/Location

The model information regarding your specific fireplace can be found on the rating plate usually located in the control area of the fireplace.

UL 127-1996, ULC-6619-M87

HEAT & GLO
 No one builds a better fire
A brand of Hearth & Home Technologies
 7871 - 219th Street West, Lakeville, MN 55444
 www.heatandglo.com

Model:
NORTH STAR
EPA CERTIFIED FIREPLACE

Serial No / Numéro De Série
009

LISTED FIREPLACE, SOLID FUEL TYPE, ALSO SUITABLE FOR MANUFACTURED HOME INSTALLATION. (UM) 84 HUD. "For Use with Solid Wood Fuel Only."
 Install and use only in accordance with manufacturer's installation, venting and operating instructions. Any area incorporating warm or cold air ducts shall be enclosed in accordance with the manufacturer's installation instructions.
 Contact Your Local Building Or Fire Officials Or Authority Having Jurisdiction About Restrictions, Installation Inspection And Permits Required In Your Area.
WARNING - For Manufactured Homes: Do not install in a sleeping room. An outside combustion air inlet must be provided and unrestricted while unit is in use. The structural integrity of the manufactured home floor, ceiling and walls must be maintained. The fireplace needs to be properly grounded to the frame of the manufactured home.
 Components required for installation: HTI SLSeries Pipe, Termination Cap, Hearth Extension and required accessory Chimney Air Kit Part CAK4A.
 Do not connect this unit to a chimney serving another appliance.
DANGER: Risk of electrical shock. Disconnect power supply before servicing.
 Electrical Rating: 115 VAC <3.0 AMPS 60 Hz
 Do not use grate or elevate fire. Build wood fire directly on firebrick.
 Do not overfire. If heater or chimney connector glows, you are overfiring.
 Do not use a fireplace insert or other products not specified for use with this product.
WARNING - THIS FIREPLACE HAS NOT BEEN TESTED WITH AN UNVENTED GAS LOG SET OR ANY LOG SET. TO REDUCE RISK OF FIRE OR INJURY, DO NOT INSTALL AN UNVENTED GAS LOG SET OR ANY LOG SET INTO FIREPLACE.
 Must provide a source of air to prevent air starvation from combustion which could result of high levels of carbon monoxide.
 Replace glass only with 5mm ceramic available from your dealer.
 Optional Fire Screen, Part SCR-433, may be used ONLY in USA

Minimum Clearances To Combustible Material
 Chimney sections at any level require a 2 inches (51mm) minimum air space clearance between the framing and chimney section.

WITHIN ENCLOSURE AREA

Appliance to backwall	1" (25mm)
Appliance to sidewall	1" (25mm)
Duct boots to framing	0" (0mm)
Top standoffs to header	0" (0mm)*

EXPOSED SURFACES

Faceplate to sidewall	16" (406mm)
Remote outlet air grills to ceiling	12" (305mm)

MANTEL

Mantel from base of fireplace	60" (1524mm)
Maximum mantel depth	12" (305mm)

FLOOR PROTECTION

Combustible flooring 20 inches (508mm) in front of and 8 inches (203mm) to either side of the fuel opening must be insulated with non-combustible floor protection with a minimum thickness of 1 inch (25mm) and ("K" value = 0.43, minimum R value 2.06).
 In Canada: The hearth extension must be installed according to the installation instructions.

This wood heater needs periodic inspection and repair for proper operation. Consult owner's manual for further information. It is against federal regulations to operate this wood heater in a manner inconsistent with the operating instructions in the owner's manual.

Mfg by: **HEARTH & HOME** Technologies

2015 2016 2017 2018 2019 2020 Jan Feb Mar Apr May June July Aug Sept Oct. Nov. Dec.

DO NOT REMOVE THIS LABEL Made in U.S.A. of US and Imported parts

U.S. ENVIRONMENTAL PROTECTION AGENCY - Certified to comply with 2015 particulate emission standards. Not approved for sale after May 15, 2020.
 This wood heater was found to have an average emissions rate of 3.3g/hr using method 5H.

480-1100M

Serial Number

Model Number

B. LIMITED LIFETIME WARRANTY

Hearth & Home Technologies LIMITED LIFETIME WARRANTY

Hearth & Home Technologies, on behalf of its hearth brands (“HHT”), extends the following warranty for HHT gas, wood, pellet, coal and electric hearth appliances that are purchased from an HHT authorized dealer.

WARRANTY COVERAGE:

HHT warrants to the original owner of the HHT appliance at the site of installation, and to any transferee taking ownership of the appliance at the site of installation within two years following the date of original purchase, that the HHT appliance will be free from defects in materials and workmanship at the time of manufacture. After installation, if covered components manufactured by HHT are found to be defective in materials or workmanship during the applicable warranty period, HHT will, at its option, repair or replace the covered components. HHT, at its own discretion, may fully discharge all of its obligations under such warranties by replacing the product itself or refunding the verified purchase price of the product itself. The maximum amount recoverable under this warranty is limited to the purchase price of the product. This warranty is subject to conditions, exclusions and limitations as described below.

WARRANTY PERIOD:

Warranty coverage begins on the date of original purchase. In the case of new home construction, warranty coverage begins on the date of first occupancy of the dwelling or six months after the sale of the product by an independent, authorized HHT dealer/ distributor, whichever occurs earlier. The warranty shall commence no later than 24 months following the date of product shipment from HHT, regardless of the installation or occupancy date. The warranty period for parts and labor for covered components is produced in the following table.

The term “Limited Lifetime” in the table below is defined as: 20 years from the beginning date of warranty coverage for gas appliances, and 10 years from the beginning date of warranty coverage for wood, pellet, and coal appliances. These time periods reflect the minimum expected useful lives of the designated components under normal operating conditions.

Warranty Period		HHT Manufactured Appliances and Venting							Components Covered
Parts	Labor	Gas	Wood	Pellet	EPA Wood	Coal	Electric	Venting	
1 Year		X	X	X	X	X	X	X	All parts and material except as covered by Conditions, Exclusions, and Limitations listed
2 years				X	X	X			Igniters, electronic components, and glass
		X	X	X	X	X			Factory-installed blowers
			X						Molded refractory panels
3 years		X							Ignition Modules
				X					Firepots and burnpots
5 years	1 year			X	X				Castings and baffles
7 years	3 years		X	X	X				Manifold tubes, HHT chimney and termination
10 years	1 year	X							Burners, logs and refractory
Limited Lifetime	3 years	X	X	X	X	X			Firebox and heat exchanger
90 Days		X	X	X	X	X	X	X	All replacement parts beyond warranty period

See conditions, exclusions, and limitations on next page.

WARRANTY CONDITIONS:

- This warranty only covers HHT appliances that are purchased through an HHT authorized dealer or distributor. A list of HHT authorized dealers is available on the HHT branded websites.
- This warranty is only valid while the HHT appliance remains at the site of original installation.
- This warranty is only valid in the country in which the HHT authorized dealer or distributor that sold the appliance resides.
- Contact your installing dealer for warranty service. If the installing dealer is unable to provide necessary parts, contact the nearest HHT authorized dealer or supplier. Additional service fees may apply if you are seeking warranty service from a dealer other than the dealer from whom you originally purchased the product.
- Check with your dealer in advance for any costs to you when arranging a warranty call. Travel and shipping charges for parts are not covered by this warranty.

WARRANTY EXCLUSIONS:

This warranty does not cover the following:

- Changes in surface finishes as a result of normal use. As a heating appliance, some changes in color of interior and exterior surface finishes may occur. This is not a flaw and is not covered under warranty.
- Damage to printed, plated, or enameled surfaces caused by fingerprints, accidents, misuse, scratches, melted items, or other external sources and residues left on the plated surfaces from the use of abrasive cleaners or polishes.
- Repair or replacement of parts that are subject to normal wear and tear during the warranty period. These parts include: paint, wood, pellet and coal gaskets, firebricks, grates, flame guides, batteries and the discoloration of glass.
- Minor expansion, contraction, or movement of certain parts causing noise. These conditions are normal and complaints related to this noise are not covered by this warranty.
- Damages resulting from: (1) failure to install, operate, or maintain the appliance in accordance with the installation instructions, operating instructions, and listing agent identification label furnished with the appliance; (2) failure to install the appliance in accordance with local building codes; (3) shipping or improper handling; (4) improper operation, abuse, misuse, continued operation with damaged, corroded or failed components, accident, or improperly/incorrectly performed repairs; (5) environmental conditions, inadequate ventilation, negative pressure, or drafting caused by tightly sealed constructions, insufficient make-up air supply, or handling devices such as exhaust fans or forced air furnaces or other such causes; (6) use of fuels other than those specified in the operating instructions; (7) installation or use of components not supplied with the appliance or any other components not expressly authorized and approved by HHT; (8) modification of the appliance not expressly authorized and approved by HHT in writing; and/or (9) interruptions or fluctuations of electrical power supply to the appliance.
- Non-HHT venting components, hearth components or other accessories used in conjunction with the appliance.
- Any part of a pre-existing fireplace system in which an insert or a decorative gas appliance is installed.
- HHT's obligation under this warranty does not extend to the appliance's capability to heat the desired space. Information is provided to assist the consumer and the dealer in selecting the proper appliance for the application. Consideration must be given to appliance location and configuration, environmental conditions, insulation and air tightness of the structure.

This warranty is void if:

- The appliance has been over-fired or operated in atmospheres contaminated by chlorine, fluorine, or other damaging chemicals. Over-firing can be identified by, but not limited to, warped plates or tubes, rust colored cast iron, bubbling, cracking and discoloration of steel or enamel finishes.
- The appliance is subjected to prolonged periods of dampness or condensation.
- There is any damage to the appliance or other components due to water or weather damage which is the result of, but not limited to, improper chimney or venting installation.

LIMITATIONS OF LIABILITY:

- The owner's exclusive remedy and HHT's sole obligation under this warranty, under any other warranty, express or implied, or in contract, tort or otherwise, shall be limited to replacement, repair, or refund, as specified above. In no event will HHT be liable for any incidental or consequential damages caused by defects in the appliance. Some states do not allow exclusions or limitation of incidental or consequential damages, so these limitations may not apply to you. This warranty gives you specific rights; you may also have other rights, which vary from state to state. EXCEPT TO THE EXTENT PROVIDED BY LAW, HHT MAKES NO EXPRESS WARRANTIES OTHER THAN THE WARRANTY SPECIFIED HEREIN. THE DURATION OF ANY IMPLIED WARRANTY IS LIMITED TO DURATION OF THE EXPRESSED WARRANTY SPECIFIED ABOVE.

2 Product Specific Information

A. Appliance Certification

Model:	NorthStar
Laboratory:	OMNI Test Laboratories, Inc.
Report No:	061-S-50-2
Type:	Wood Fireplace
Standard:	UL 127-2011 and ULC-S610-M87 (A1998) and (UM) 84-HUD, Manufactured Home Approved

Warning! Risk of Fire!

For use with solid wood fuel only.

Other fuels may overfire and generate poisonous gases (i.e. carbon monoxide).

B. BTU & Efficiency Specifications

EPA Certification #:	569
EPA Certified Emissions:	3.3 grams per hour
*LHV Tested Efficiency:	77.2 %
**HHV Tested Efficiency:	71.5%
***EPA BTU Output:	11,300 to 51,200 / hr.
****Peak BTU/Hour Output:	74,900
Vent Size:	6 inches
Firebox Size:	2.7 cubic feet
Recommended Log Length:	22 inches
Fuel	Seasoned Cord Wood
* * Weighted average LHV (Low Heating Value) efficiency using Douglas Fir dimensional lumber and data collected during EPA emission test. LHV assumes the moisture is already in a vapor state so there is no loss in energy to vaporize.	
****Weighted average HHV (High Heating Value) efficiency using Douglas Fir dimensional lumber and data collected during EPA emission test. HHV includes the energy required to vaporize the water in the fuel.	
***A range of BTU outputs based on EPA Default Efficiency and the burn rates from the low and high EPA tests, using Douglas Fir dimensional lumber.	
****A peak BTU out of the appliance calculated using the maximum first hour burn rate from the High EPA Test and the BTU content of cordwood (8600) times the efficiency.	

The Heat & Glo Northstar meets the 2015 US Environmental Protection Agency's crib wood emission limits for wood heaters sold after May 15, 2015.

This wood heater needs periodic inspection and repair for proper operation. It is against federal regulations to operate this wood heater in a manner inconsistent with operating instructions in this manual.

C. Mobile Home Approved

- This appliance is approved for mobile home installations when not installed in a sleeping room and when an outside combustion air inlet is provided.
- The structural integrity of the mobile home floor, ceiling, and walls must be maintained.
- The appliance must be properly grounded to the frame of the mobile home with #8 copper ground wire.
- Outside Air Kit must be installed in a mobile home installation.

D. Glass Specifications

This fireplace is equipped with 5mm ceramic glass. Replace glass only with 5mm ceramic glass. Please contact your dealer for replacement glass.

3 Important Safety and Operating Information

A. Fireplace Safety

Most problems are caused by improper installation and operation of the fireplace. To provide reasonable fire safety, the following should be given serious consideration:

- The fire should be supervised whenever the fireplace is in use.
- An annual inspection should be performed on the fireplace system.
- Install at least one smoke detector on each floor of your home to ensure your safety.
- Install a conveniently located Class A fire extinguisher near the fireplace.
- Devise a practiced evacuation plan, consisting of at least two escape routes.
- Devise a plan to deal with a chimney fire:
 - Close all openings into the stove.
 - Evacuate.
 - Notify the fire department.

WARNING! Risk of Fire! *Hearth & Home Technologies disclaims any responsibility for, and the warranty and agency listing will be voided by the following actions.*

DO NOT:

- operate damaged fireplace
- modify fireplace
- overfire
- install any gas log set
- install any component not approved by *Hearth & Home Technologies*
- install parts or components not Listed or approved
- operate the fireplace without fully assembling all components

Improper installation, adjustment, alteration, service or maintenance can cause injury or property damage.

1. Clear Space

Combustible materials must not be stored on the hearth extension. Room furnishings such as drapes, curtains, chairs or other combustibles must be at least 4 ft (1219 mm) from the open front of the fireplace.

Combustible materials are materials made of or surfaced with any of the following materials:

- Wood
- Plant fibers
- Plywood/OSB
- Any material that can ignite and burn, flame proofed or not, plastered or un-plastered.
- Compressed paper
- Plastic
- Drywall

Non-combustible materials are materials which will not ignite and burn, composed of any combination of the following:

- Steel
- Brick
- Concrete
- Glass
- Iron
- Tile
- Slate
- Plasters

WARNING! Risk of Fire! *Keep combustible materials, gasoline and other flammable vapors and liquids clear of the fireplace.*

DO NOT:

- store flammable materials close to the fireplace
- use gasoline, lantern fuel, kerosene, charcoal lighter fluid or similar liquids to start or "freshen up" a fire in this fireplace.

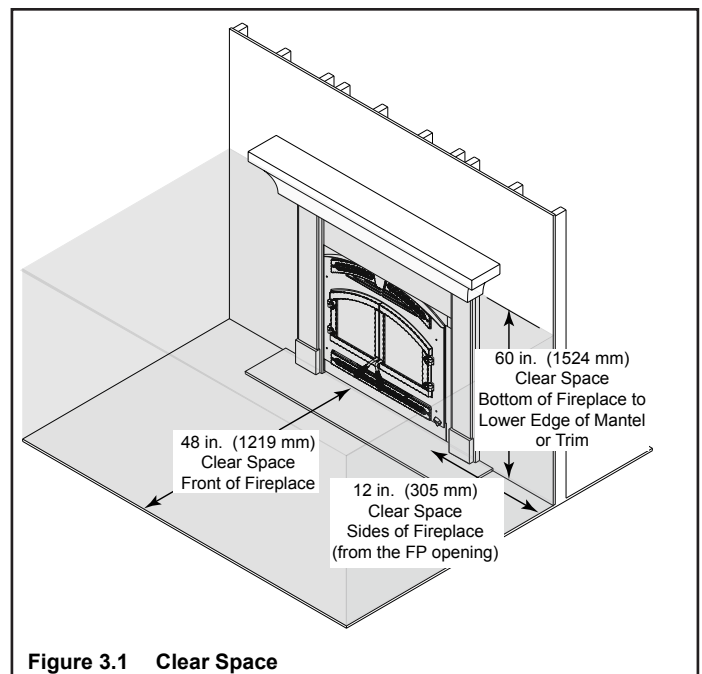

2. Firebrick

Your fireplace is lined with high quality firebrick, which has exceptional insulating properties.

Do not operate the fireplace without bricks. Make sure bricks are installed as shown in Section 5.

Do not use a grate; simply build a fire on the firebox floor.

3. Baffle and Blanket

Ensure correct baffle and baffle protection channel placement; replace baffle components if damaged or missing. (Please refer to Section 5.)

NOTICE: Firebox damage due to improper baffle placement is not covered by warranty. Operate the wood burning fireplace with the baffle in the correct position only. Not doing so could result in:

- reduced efficiency
- overheating the chimney
- overheating the rear of the firebox
- poor performance

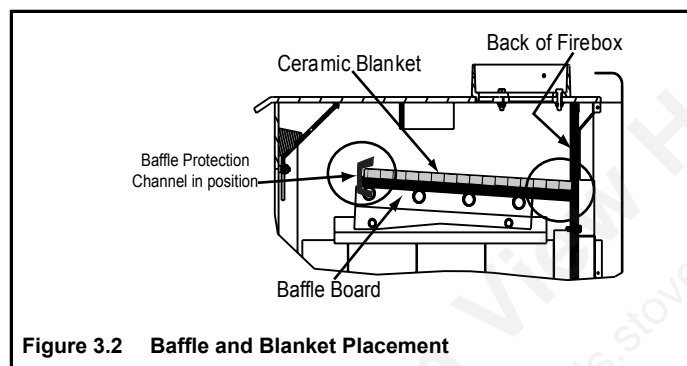

Figure 3.2 Baffle and Blanket Placement

4. Over-Firing Your Fireplace

WARNING! Risk of Fire! Do not over-fire.

Over-firing may ignite creosote or will damage the fireplace and chimney.

To prevent over-firing your fireplace. DO NOT:

- use flammable liquids
- overload with wood
- burn trash or large amounts of scrap lumber
- permit too much air to the fire

Symptoms of over-firing may include one or more of the following:

- chimney connector or fireplace glowing
- roaring, rumbling noises
- loud cracking or banging sounds
- metal warping
- chimney fire

What to do if your stove is over-firing:

- Immediately close the door and air controls to reduce air supply to the fire.
- If you suspect a chimney fire, call the fire department and evacuate your house.
- Contact your local chimney professional and have your stove and stove pipe inspected for any damage.
- Do not use your stove until the chimney professional informs you it is safe to do so.
- Hearth & Home Technologies WILL NOT warranty stoves that exhibit evidence of over-firing. Evidence of over-firing includes, but is not limited to:
 - warped air tube
 - deteriorated refractory brick retainers
 - deteriorated baffle and other interior components

5. Chimney Fire

In the event of a chimney fire

- Have the chimney and adjacent structure inspected by qualified professionals. Hearth & Home Technologies recommends that NFI or CSIA certified professionals, or technicians under the direction of certified professionals, conduct a minimum of an **NFPA 211 Level 2** inspection of the chimney.
- Replace components of the chimney and fireplace as specified by the professionals.
- Ensure all joints are properly engaged and the chimney is properly secured.

WARNING! Risk of Fire! A chimney fire can permanently damage your chimney system. Failure to replace damaged components and make proper repairs can cause a structure fire.

WARNING



HOT SURFACES!

Glass and other surfaces are hot during operation AND cool down.

Hot glass will cause burns.

- **DO NOT** touch glass until it is cooled
- NEVER allow children to touch glass
- Keep children away
- CAREFULLY SUPERVISE children in same room as fireplace.
- Alert children and adults to hazards of high temperatures.

High temperatures may ignite clothing or other flammable materials.

- Keep clothing, furniture, draperies and other flammable materials away.

B. General Operating Parts

WARNING! DO NOT operate fireplace before reading and understanding operating instructions. Failure to operate fireplace according to operating instructions could cause fire or injury.

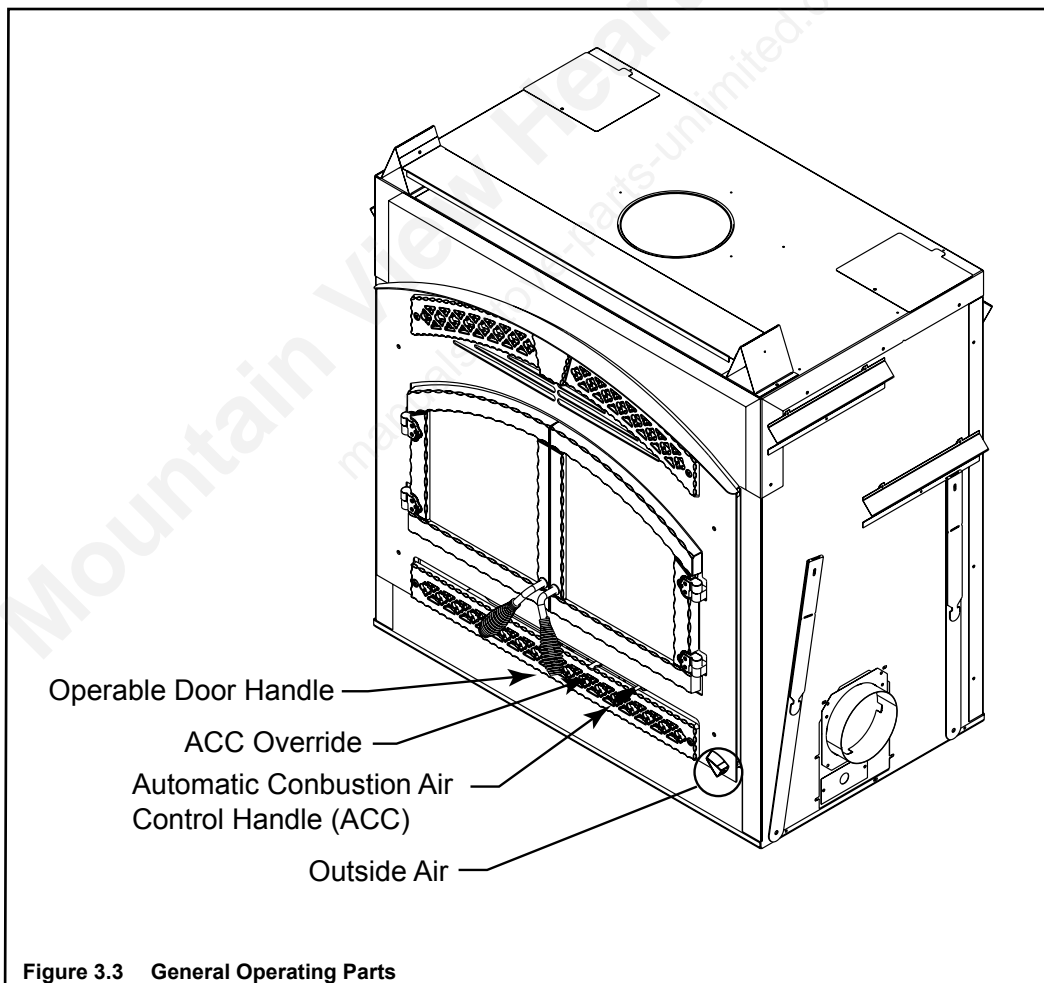

Figure 3.3 General Operating Parts

1. Automatic Combustion Control (ACC)

The automatic combustion control system allows you to set the fireplace to high (slide the combustion air control all the way to the right), start the fire, and then move the combustion air control to the desired burn level. The fire will automatically go to that level once it is fully established. This allows for less interaction with the fire by the homeowner and more efficient use of fuel while maintaining the desired heat output.

After the fireplace becomes hot, you may prefer to not activate the ACC when reloading fuel. If you do not slide the combustion air control all the way to the right, the ACC will not be activated.

NOTICE: To establish your settings, always begin with the air control all the way to the left to STOP and then move it to the right for your desired setting.

IMPORTANT! As you move the combustion air control to the RIGHT, you will feel resistance about three-fourths of the way. You must move past that resistance approximately 3/4 in. (19mm) to fully engage the automatic combustion control (ACC) system.

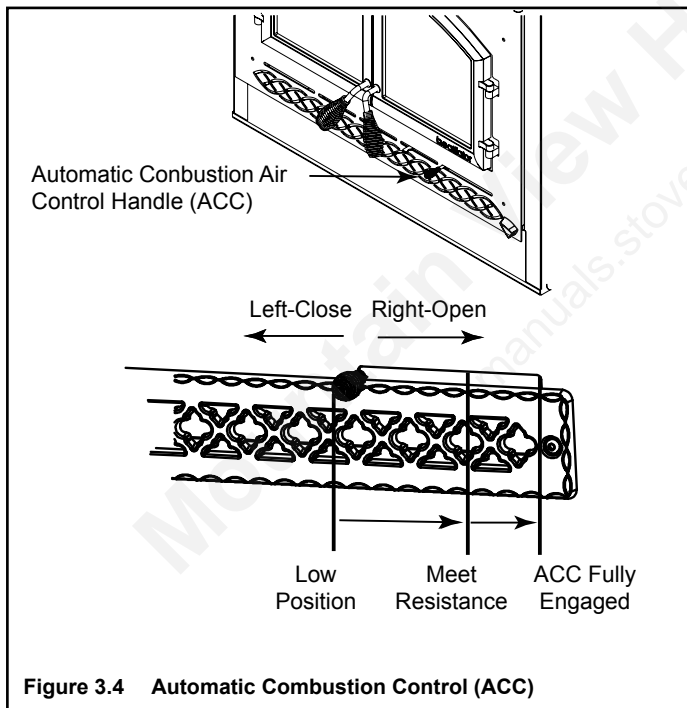

2. ACC Override

The lever located to the left of the combustion air control is the ACC OVERRIDE and may be used to override the setting of the automatic combustion air control. If the ACC has been activated and burn rate needs to be slowed, move the lever to the LEFT and position combustion air control at the preferred setting. To close the air supply for an over-fire situation or to slow the burn rate down immediately, slide the lever to the LEFT and also slide the combustion air control all the way to the left.

NOTICE: If reloading a bright, hot coal bed for longer (low) burn time, setting the ACC may not be required. Burn dry, well seasoned wood.

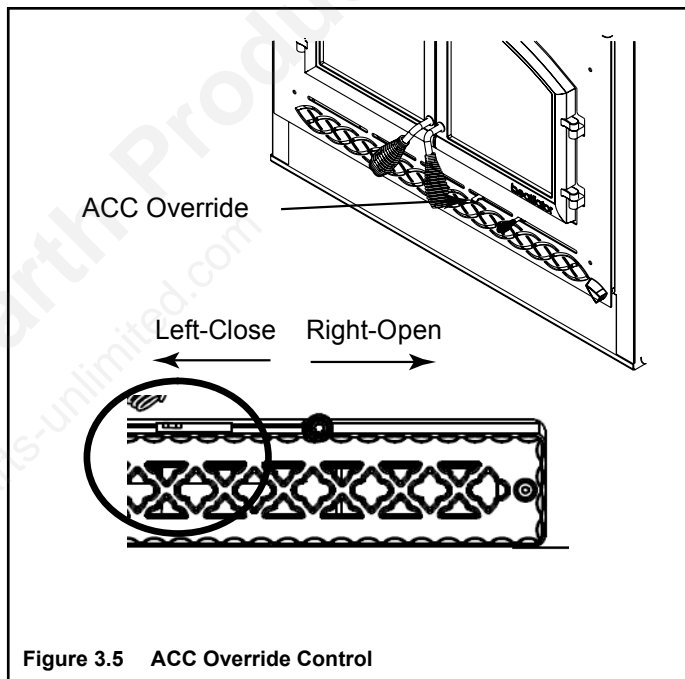

3. Outside Air

NOTICE: Use of outside air is required.

A source of air (oxygen) is required in order for combustion to take place.

Turning the outside air handle clockwise closes the outside air inlet; turning counterclockwise will open it. This may be closed only when the fireplace is not in use to prevent cold air infiltration.

CAUTION! Outside air control handle may be warm. Adjust before lighting fire.

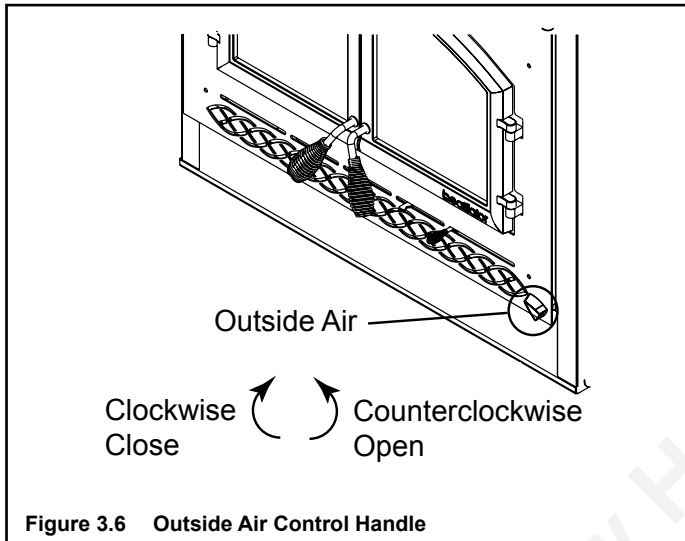

4. Glass Doors

This fireplace has been tested and is intended for use with doors as supplied with this fireplace.

WARNING! Risk of Fire and Smoke! Fireplace should be operated only with doors fully open or doors fully closed. If doors are left partly open, gas and flame may be drawn out of the fireplace opening.

A firescreen (MESH-HHT) must be used to control sparks if the homeowner chooses to operate the fireplace with the doors open.

WARNING! Fire Risk!

- Use firescreen when burning fireplace with doors open.
- Do not use firescreen or glass doors to hold burning material in fireplace.

Firescreen controls sparks.

Glass may break or burning material may roll out.

Only the screen specifically tested and listed for use with this fireplace model should be used.

WARNING! RISK OF Fire! Do NOT install and or use any component not approved by Hearth & Home Technologies.

Always wear gloves when installing or removing the screen as the screen may become extremely hot while in use.

5. Convection Fan Operation

The fireplace is equipped with a temperature-sensitive snap disc that will turn the convection fan on and off automatically, depending on the temperature of the fireplace.

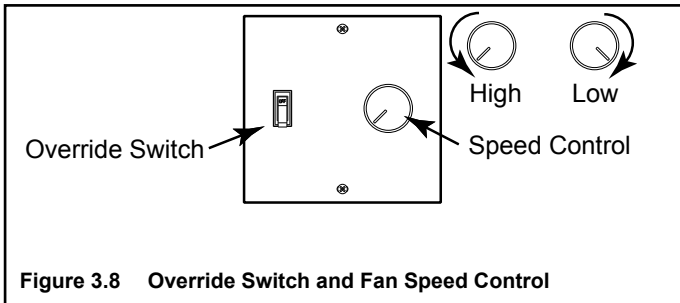

Figure 3.8 Override Switch and Fan Speed Control

An override switch and fan speed control have been installed on the wall in close proximity to the fireplace.

The speed of the fan can be regulated by the speed control knob.

If the fan is not coming on at the desired time, flip the override switch to manual and operate the fan as described below:

- **Initial (cold) Startup**

Leave fan off until your fireplace is hot and a good coal bed is established, approximately 30 minutes after fuel is lit.

- **High Burn Setting**

The fan may be left on throughout the burn.

- **Medium or Medium High Burn Setting**

The fan should be left off until a good burn is established, then turned on medium or high rate.

- **Low Burn Setting**

The fan tends to cool off the fireplace. Leave fan off until the burn is well established; then, if you wish, turn the fan on at a low rate.

C. Fuel

WARNING! For use with solid wood fuel only.

Other fuels may overfire and generate poisonous gases (i.e. carbon monoxide).

DO NOT BURN:

- Garbage
 - Lawn clippings or yard waste
 - Materials containing rubber, including tires
 - Materials containing plastic
 - Waste petroleum products, paints or paint thinners, or asphalt products
 - Materials containing asbestos
 - Construction or demolition debris
 - Railroad ties or pressure-treated wood
 - Manure or animal remains
 - Salt water driftwood or other previously salt water saturated materials
 - Unseasoned wood
 - Paper products, cardboard, plywood, or particleboard.
- The prohibition against burning these materials does not prohibit the use of fire starters made from paper, cardboard, saw dust, wax and similar substances for the purpose of starting a fire in an affected wood heater.
- Burning these materials may result in release of toxic fumes or render the heater ineffective and cause smoke.

1. Hardwood vs. Softwood

Your fireplace's performance depends on the quality of the firewood you use. One species of wood varies very little to the other in terms of energy content. All seasoned wood contains about 8,000 BTU's per pound. Hardwoods have a greater density than softwoods; a piece of hardwood will contain about 60% more BTU's than an equal size piece of softwood. A cord of seasoned oak (hardwood) would contain about 60% more potential energy than a cord of seasoned pine (softwood).

Most softwoods are coniferous. These are trees with needle-like leaves that stay green all year and carry their seeds exposed in a cone. Examples of coniferous trees are Douglas fir, pine, spruce and cedar. Softwoods, being more porous, require less time to dry, burn faster and are easier to ignite than hardwoods. Hardwoods are deciduous trees, broadleaf trees that lose their leaves in the fall. Their seeds are usually found within a protective pod or enclosure. Some examples of deciduous trees are oak, maple, apple, and birch. However, it should be noted that there are some

deciduous trees that are definitely not considered hardwoods such as poplar, aspen and alder. Hardwoods require more time to season, burn slower and are usually harder to ignite than softwoods. Obviously, you will use the type of wood that is most readily available in your area. However, if at all possible the best arrangement is to have a mix of softwood and hardwood. This way you can use the softwood for starting the fire, giving off quick heat to bring the fireplace up to operating temperature. Add the hardwood for slow, even heat and longer burn time.

WARNING! Risk of Fire!

- **DO NOT** burn wet or green wood.
- Wet, unseasoned wood can cause accumulation of creosote.

Soft woods	Hard woods
• Douglas Fir	• Oak
• Pine	• Maple
• Spruce	• Apple
• Cedar	• Birch
• Poplar	
• Aspen	
• Alder	

2. Moisture content

The majority of the problems fireplace owners experience are caused by trying to burn wet, unseasoned wood. Freshly cut wood can be as much water as it is wood, having a moisture content of around 50%. Imagine a wooden bucket that weighs about 8 pounds. Fill it with a gallon of water, put it in the firebox and try to burn it. This sounds ridiculous but that is exactly what you are doing if you burn unseasoned wood. Dead wood lying on the forest floor should be considered wet, and requires full seasoning time. Standing dead wood can be considered to be about two-thirds seasoned, if cut at the dry time of the year.

Burning wet, unseasoned wood will produce less heat output because it requires energy in the form of heat to evaporate the water trapped inside. This is wasted energy that should be used for heating your home. This moisture evaporates in the form of steam which has a cooling effect in your firebox and chimney system. When combined with tar and other organic vapors from burning wood it will form creosote which condenses in the relatively cool firebox and chimney.

Even dry wood contains at least 15% moisture by weight, and should be burned hot enough to keep the chimney hot for as long as it takes to dry the wood out - about one hour. To tell if wood is dry enough to burn, check the ends of the logs. If there are cracks radiating in all directions from the center, it is dry. If your wood sizzles in the fire, even though the surface is dry, it may not be fully cured.

3. Seasoning

Seasoned firewood is nothing more than wood that is cut to size, split and air dried to a moisture content of around 20%. The time it takes to season wood varies from around nine months for soft woods to as long as eighteen months for hardwoods. The key to seasoning wood is to be sure it has been split, exposing the wet interior and increasing the surface area of each piece. A tree that was cut down a year ago and not split is likely to have almost as high a moisture content now as it did when it was cut.

To season wood:

- Cut logs to size
- Split to 6 in. (152 mm) or less
- Air dry to a moisture content of around 20%
 - Soft wood - about nine months
 - Hard wood - about eighteen months

NOTICE: Seasoning time may vary depending on drying conditions.

4. Storing Wood

Splitting wood before it is stored reduces drying time. The following guideline will ensure properly seasoned wood:

- Stack the wood to allow air to circulate freely around and through the woodpile.
- Elevate the woodpile off the ground to allow air circulation underneath.
- The smaller the pieces, the faster the drying process. Any piece over 6 in. (152 mm) in diameter should be split.
- Wood should be stacked so that both ends of each piece are exposed to air, since more drying occurs through the cut ends than the sides. This is true even with wood that has been split.
- Store wood under cover, such as in a shed, or covered with a tarp, plastic, tar paper, sheets of scrap plywood, etc., as uncovered wood can absorb water from rain or snow, delaying the seasoning process. Avoid covering the sides and ends completely. Doing so may trap moisture from the ground and impede air circulation.

5. Burning Process

Fire requires fuel, air and heat. If heat is robbed from the fireplace during the drying stage, the new load of wood has reduced the chances for a good clean burn. Always burn dry, seasoned firewood.

- **Kindling or 1st stage:**

In this stage, the wood is heated to a temperature high enough to evaporate the moisture which is present in all wood. The wood will reach the boiling point of water (212°F) and will not get any hotter until the water is evaporated. This process takes heat from coals and tends to cool the fireplace.

- **2nd stage:**

The secondary stage is when the wood gives off flammable gases which burn above the fuel with bright flames. It is very important that the flames be maintained and not allowed to go out. This will ensure the cleanest possible fire. You should close down the air to control the point where you can still maintain some flame. If the flames tend to go out, more air is necessary.

- **Final stage:**

The final stage of burning is the charcoal stage. This occurs when the flammable gases have been mostly burned and only charcoal remains. This is a naturally clean portion of the burn. The coals burn with hot blue flames.

It is very important to reload your fireplace while enough lively hot coals remain in order to rekindle the next load of wood.

6. Dirty Glass

A portion of the combustion air entering the firebox is deflected down over the inside of the door glass. This air flow “washes” the glass, helping to keep smoke from adhering to its surface. When operated at a low burn rate, less air will be flowing over the glass and the smoky, relatively cool condition of a low fire will cause the glass to become coated. Operating the fireplace with the burn rate air control and start-up air control all the way open for 15-20 minutes should remove the built up coating.

7. Creosote Formation

When wood is burned slowly, it produces tar and other organic vapors which combine with expelled moisture to form creosote. The creosote vapors condense in the relatively cool chimney flue of a newly-started or a slow-burning fire. As a result, creosote residue accumulates on the flue lining.

When ignited, creosote creates an extremely hot fire which may damage the chimney or even destroy the house.

The chimney shall be inspected at least annually before lighting, or once every two months during heating season.

When creosote has accumulated it shall be removed to reduce the risk of a chimney fire.

8. Opacity

Opacity indicates how cleanly your fireplace is burning. Opacity is measured in percent; 100% opacity is when an object is totally obscured by the smoke column from a chimney, and 0% opacity means that no smoke column can be seen. Periodically check the opacity and burn your fireplace as nearly smoke-free as possible (goal of 0% opacity).

D. First Fire

Before lighting your first fire in the fireplace, make certain that:

- the baffle and ceramic blanket are correctly positioned, resting against the rear support
- firebrick are in place
- all labels have been removed
- all plated surfaces have been cleaned

NOTICE: Oils can cause permanent markings on plating if not removed before the first fire.

NOTICE: The first three or four fires should be of moderate size to allow the oils and binders to be burned from the fireplace and the refractory and paint to cure. You may notice an industrial odor the first few fires. This is considered normal.

E. Lighting Instructions

To start a fire, light easily-ignitable tinder or paper, which will ignite the fast burning kindling, which in turn will ignite the slow-burning firewood.

- Open outside air by turning the knob counter clockwise.
- Fully open the combustion air control by moving the Automatic Combustion Air Control (ACC) handle completely to the right.
- Place several wads of crushed paper on the firebox floor. Heating the flue with a burning, rolled up newspaper before adding kindling keeps smoke spillage to a minimum.
- Lay small dry sticks of kindling on top of the paper.
- Make sure that no matches or other combustibles are in the immediate area of the fireplace. Be sure the room is adequately ventilated and the flue unobstructed.
- Light the paper in the fireplace. **NEVER light or rekindle fireplace with kerosene, gasoline, or charcoal lighter fluid; the results can be fatal.**
- Once the kindling is burning quickly, add several full-length logs 3 in. (76 mm) or 4 in. (102 mm) in diameter. Be careful not to smother the fire. Stack the pieces of wood carefully; near enough to keep each other hot, but far enough away from each other to allow adequate air flow between them.
- Adjust the combustion air control; the more you close down the ACC handle, (sliding left) the lower and slower the fire will eventually burn. The more you open the air control, (sliding right) the more heat will be produced and the faster the wood will burn.
- Refueling: Move the ACC to the right, allow an influx of air to liven the coalbed. The door should be opened slowly to prevent ash and smoke spillage into the room. Break up any large chunks and distribute the coals so new wood is laid evenly on hot coals. Add desired amount of fuel, close the door.

NOTICE: Fireplace should be run full open for a minimum of 30 minutes a day during heating season to keep air passages clean.

WARNING! Risk of Fire! Keep combustible materials, gasoline and other flammable vapors and liquids clear of the fireplace.

DO NOT:

- store flammable materials close to the fireplace
- use gasoline, lantern fuel, kerosene, charcoal lighter fluid or similar liquids to start or “freshen up” a fire in this fireplace.

Keep all flammable liquids well away from the fireplace while it is in use. Combustible materials may ignite.

F. Heat Management

For maximum operating efficiency with the lowest emissions, follow these operating procedures:

- Regardless of desired heat output, when loading the fireplace, burn your fireplace with the combustion air control wide open (fully to the right) for a minimum of 5 to 15 minutes (refer to Figure 4.1).
- Regulate burn rate (heat output) by using the combustion air control.
- Heat output settings: Follow the burn rate instructions listed Table 4.1.

Table 4.1

Burn Rate	BTU / Hr	*Combustion Air Control
Low	Below 10,000	Slide LEFT to Stop
Medium	10,000 - 15,000	Stop to 1/8 in. - 1/2 in. open
Medium High	15,000 - 30,000	Stop to 1/2 in. - 1-1/2 in. open
High	Maximum Heat	All the way to RIGHT

*These are approximate settings, and will vary with type of wood or chimney draft.

This wood heater has a manufacturer-set minimum low burn rate that must not be altered. It is against federal regulations to alter this setting or otherwise operate this wood heater in a manner inconsistent with operating instructions in this manual.

4 Maintenance and Service

WARNING! Hot Surfaces!

Glass and other surfaces are hot during operation AND cool down. **DO NOT** clean fireplace until it is cooled.

Task	Frequency	To be completed by
1. Chimney Inspection	As needed	Homeowner or Chimney Sweep
2. Chimney Cleaning	As needed	Chimney Sweep
3. Plated Surfaces Cleaning	As needed	Homeowner
4. Glass Doors	Seasonally	
5. Glass Cleaning	As needed	
6. Door Gasket	Seasonally	
7. Ash Removal	As needed	
8. Baffle/Blanket/Channel Protector	Seasonally	
9. Firebrick	Seasonally	

A. Maintenance Tasks-Homeowners

Installation and repair should be done by a qualified service technician only. The fireplace should be inspected before use and at least annually by a professional service person.

The following tasks may be performed annually by the homeowner. If you are uncomfortable performing any of the listed tasks, please call your dealer for a service appointment.

1. Chimney Inspection

Frequency: As necessary; at least annually before lighting fireplace, or once every two months during heating season.

By: Homeowner/Chimney Sweep

- Confirm that termination cap remains clear and unobstructed.
- Inspect for blockages such as bird nests, leaves, etc.
- Inspect for corrosion or separation.
- Inspect for creosote and remove as needed, at least every two months during the heating season.
- Inspect the system at the fireplace connection and at the chimney top.

In the event of a chimney fire, Hearth & Home Technologies recommends replacement of the chimney and inspection of the adjacent structure to the provisions of NFPA Level III inspection criteria.

WARNING! Risk of Asphyxiation and Fire! Annual inspection by qualified technician recommended.

Check:

- condition of doors, surrounds and fronts
- condition of glass and glass assembly
- obstructions of combustion and ventilation air
- obstructions of termination cap

Clean:

- glass
- air passageways, grilles

2. Creosote (Chimney) Cleaning

Frequency: As needed; at least annually before lighting, or once every two months during heating season. When creosote has accumulated it shall be removed to reduce the risk of a chimney fire.

By: Chimney Sweep

Tools Needed: Brush, allen wrench, Phillips screw-driver

- When wood is burned slowly, it produces tar and other organic vapors, which combine with expelled moisture to form creosote. The creosote vapors condense in the relatively cool chimney flue of a slow-burnign fire. As a result, creosote residue accumulates on the flue lining. When ignited, this creosote makes an extremely hot fire.
- Remove all ash from the firebox and extinguish all hot embers before disposal. Allow the fireplace to cool completely.
- Remove baffle and ceramic blanket from fireplace before cleaning chimney (refer to Section 5.C.3 Baffle Removal and Installation).
- Close the door tightly.
- Remove the top of the termination cap as shown in Figure 4.1 to clean the cap and chimney.
- The creosote or soot should be removed from the chimney with a brush specifically designed for the size of chimney in use.
- Reinstall termination cap.
- Clean out fallen debris from the firebox.
- Replace baffle and ceramic blanket.

WARNING! Risk of Fire! Ignited creosote is extremely HOT. Prevent creosote buildup.

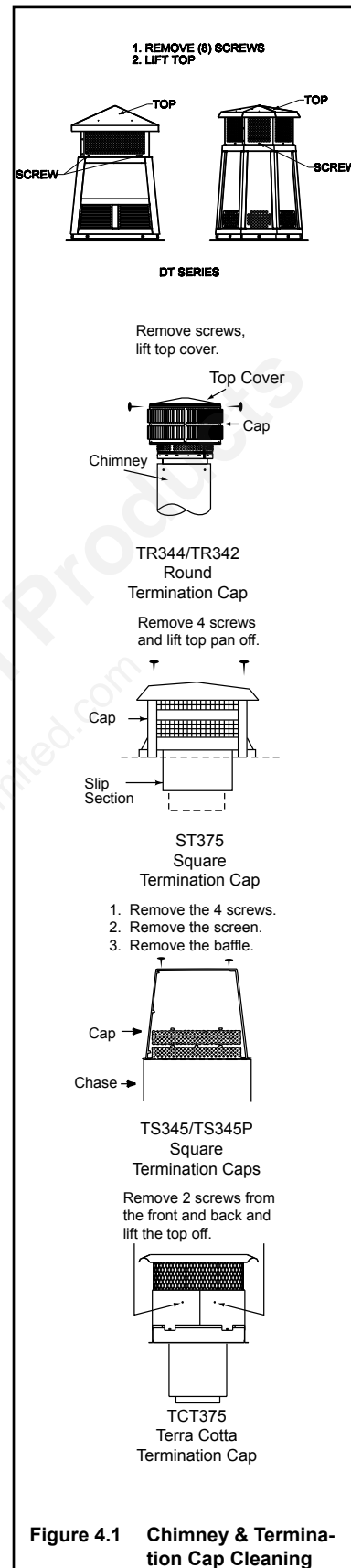

3. Care and Cleaning of Plated Surfaces

Frequency: Initially and as needed

By: Homeowner

Tools Needed: Vinegar or glass cleaner, soft towel

CAUTION! Do not use a polish with abrasives. It will scratch plated surfaces.

- Use a glass cleaner or vinegar and towel to remove the oils.
- Oils can cause permanent markings on plating if not removed.
- After plating is cured, oils will not affect the finish.

4. Glass Doors

Frequency: As necessary

By: Homeowner

- Inspect glass panels for cracks. Replace if this condition is present.
- Inspect glass gasket. Confirm glass does not move around in glass frame.

5. Glass Cleaning

Frequency: As necessary

By: Homeowner

Tools Needed: Vinegar or glass cleaner, soft towel

- Clean glass with a non-abrasive glass cleaner. Use a damp cloth dipped in wood ashes or a commercially available oven cleaner. Remove any oven cleaner residue with a glass cleaner or soap and water.

6. Door Gasket

Frequency: Seasonally

By: Homeowner

- Open door, place half a dollar bill inside and close the door.
- Attempt to pull the bill out.
- If the bill gives good resistance or is not removable, the gasket is adjusted correctly. If the bill is easily removed, the gasket needs adjustment or replacement to create an even seal all around door.

It may be necessary to adjust or tighten the door latch.

7. Ash Removal

Frequency: As necessary

By: Homeowner

Tools Needed: Covered metal container, metal shovel, fireplace broom

WARNING! Risk of Fire! DO NOT remove ashes until the fire is out and the fireplace is cold.

- Ashes should be placed in metal container with tight fitting lid.
- The closed container of ashes should be placed on a noncombustible floor or on the ground, well away from all combustible materials, pending final disposal.
- If the ashes are disposed of by burial in soil or otherwise locally dispersed, they should be retained in the closed container until all cinders have thoroughly cooled.

8. Baffle and Blanket

Frequency: As necessary

By: Homeowner

Tools Needed:

- Ensure correct baffle and baffle protection channel placement; replace baffle components if damaged or missing.
- The ceramic blanket and baffle board **MUST** be in contact with the back of the firebox and even with each other in the front. The baffle protection channel **MUST** be in position. Refer to Section 3.A.3.

9. Firebrick

Frequency:

By:

Tools Needed:

- Inspect condition of brick. Replace if crumbly or otherwise deteriorated, or if cracks exceed 1/4 in. (6 mm).

B. Replacement Maintenance

1. Glass Replacement

- Ensure that the fire is out and the fireplace is cool to the touch.
- Protect a table or counter top with padding or towels.
- Remove door with broken glass from the fireplace by lifting door up and off of the hinges.
- Lay door face down on table or counter making sure handle and handle attachment knob hang over the edge of the table top so door lays flat on the soft surface.
- Remove screws from the top and bottom glass frames (five on each door) using a #2 Phillips Head screwdriver. Set frames aside and retain screws.
HINT: Soak screws in penetrating oil for easy removal.
- Remove the glass and discard.
- Position the new glass with edges evenly overlapping the opening in the front door.
- Replace the glass frames.
- Start screws to secure glass frames to door, keeping them loose for adjusting the glass. Then continue to tighten each screw alternately, a few turns at a time, until the glass panel is tightened snugly. **DO NOT OVERTIGHTEN OR CROSS THREAD SCREWS.**
- Replace the door on the fireplace.
- After the first burn, recheck the tightness of the screws.

NOTICE: Remove all labels from glass before lighting the first fire in your fireplace.

2. Tighten or Adjust Door Latch

Remove the lock nut holding latch cam and four spacing washers on the right hand door as shown in Figure 5.2. Move 1-3 spacing washers to the opposite side of cam. Reinstall the cam and tighten locknut. At least one spacing washer and the black washer must be left in place.

OR

Replace the gasket material. Wear or damage to the gasket material can cause air leakage into the firebox resulting in overfiring and loss of efficiency.

A replacement gasket is available from your dealer.

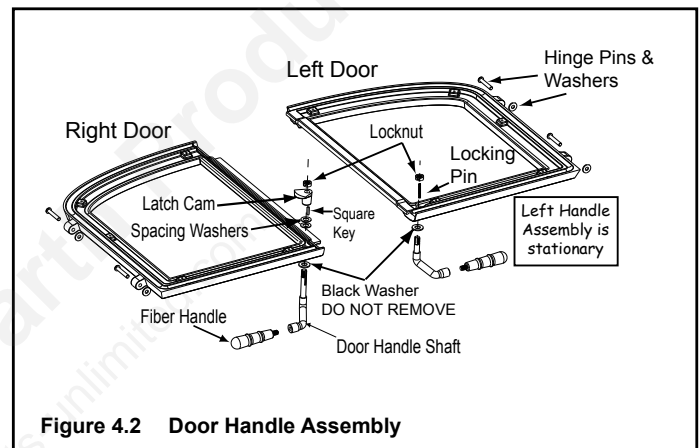

3 Firebrick Replacement

The firebox of your fireplace is lined with high quality firebrick, which has exceptional insulating properties. There is no need to use a grate; simply build a fire on the firebox floor. Do not operate the fireplace without bricks.

IMPORTANT: The bricks are very similar in size. Be certain you have the proper brick in the correct location. Measure the brick size for accuracy.

After the coals are completely cooled, remove all old firebrick and ash from unit and vacuum out firebox.

- Remove new brick set from box and lay out to diagram shown in Figure 4.3.
- Lay bottom bricks in unit.
- Install rear bricks on the top of the bottom bricks. Slide top of bricks under clip on back of firebox wall and push bottom of brick back.
- Install side bricks. Slide top of brick under clips on side of firebox and push the bottom of the brick until it is flush with the side of the unit.

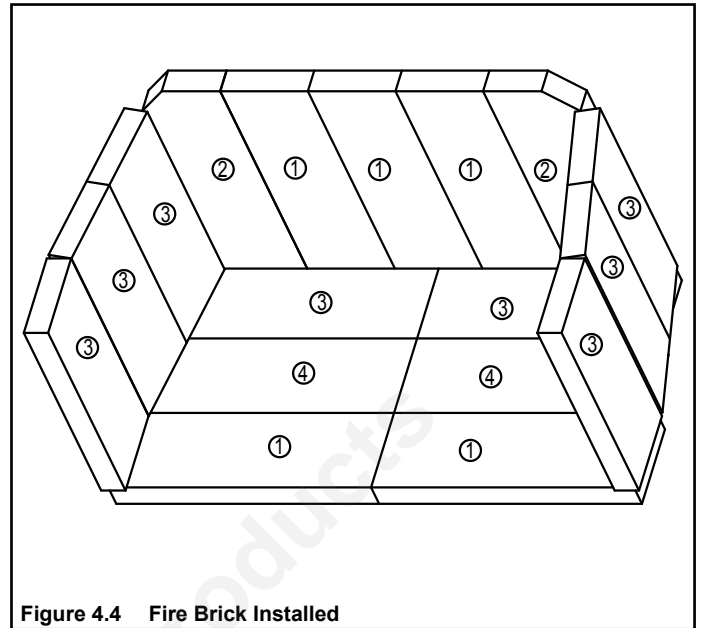

Figure 4.4 Fire Brick Installed

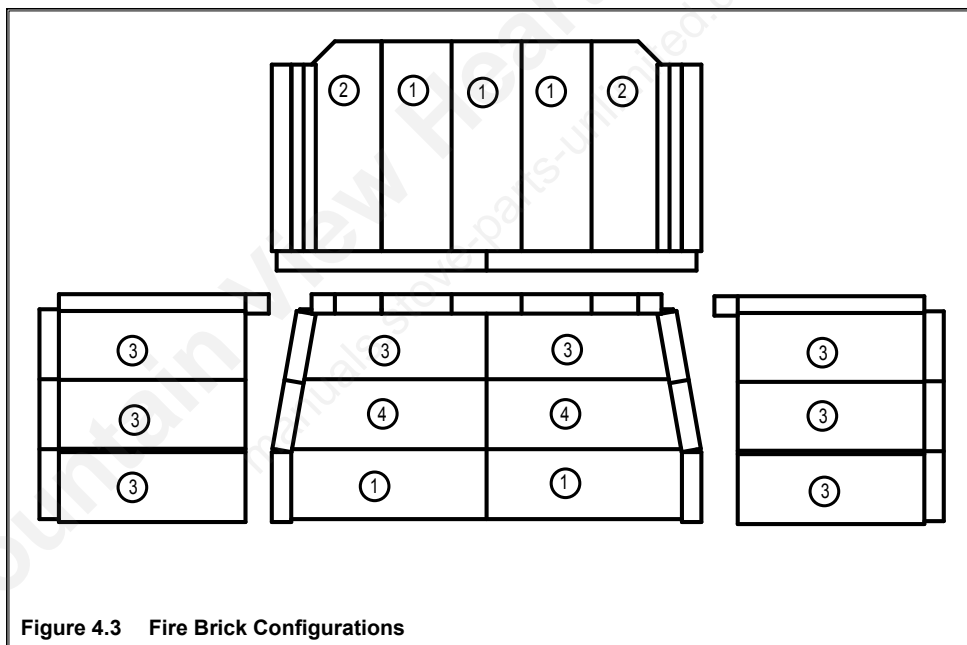
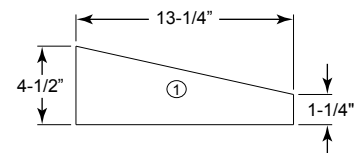

Figure 4.3 Fire Brick Configurations

#	Brick Size	Qty. in Set
1	13-1/4" x 4-1/2" x 1-1/4"	5
2	13-1/2" x 4-1/2" x 1-1/4" w/ 1-1/2 chamfer	2
3	12" x 4-1/2" x 1-1/4"	8
4	12-1/2" x 4-1/2" x 1-1/4"	2



4. Baffle Removal and Installation

WARNING! Hot Surfaces!

Glass and other surfaces are hot during operation AND cool down. **DO NOT** clean fireplace until it is cooled.

- Remove all ash from firebox and place into a metal container.
- Remove the baffle protection channel by turning it down and pulling it out of the firebox. See Figure 4.5.



Figure 4.5 Removing Baffle Protection Channel

- Remove ceramic blanket from above the baffle.
- With a 3/16 in. Allen wrench, remove the front manifold tube retainer bolt on the air channel under the end of the front tube. See Figure 4.6.



Figure 4.6 Removing Manifold Tube

NOTICE: Soak the bolt with penetrating oil for at least 15 minutes before trying to remove it.

- To remove manifold tube, slide the tube to one side until one end is out of its hole. Then, while lifting that end of the fiber board baffle, pull tube up over the air channel and out of hole at the other end. It is only necessary to remove the first tube in order to remove the baffle.
- Slide fiber board baffle forward to front of fireplace and straight out through door. See Figure 4.7.
- To install the fiber board baffle, repeat the 2nd through 4th steps in reverse. Be sure the fiber board baffle and ceramic blanket are pushed back fully and the blanket is down and flat.

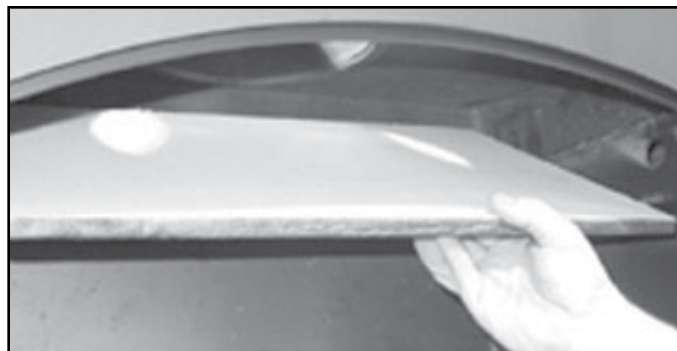

Figure 4.7 Removing Baffle (shown without ceramic blanket)

5. Fan Replacement

CAUTION! Risk of Shock! Disconnect power by turning off circuit breaker before servicing.

CAUTION! Risk of Shock!

- **DO NOT** remove grounding prong from plug.
- Plug directly into properly grounded three-prong receptacle.
- Route cord away from fireplace.
- **DO NOT** route cord under or in front of fireplace.

The Fireplace comes equipped with two fans, installed at the factory with electric access on the right side of fireplace (as you face it).

- Fan Replacement Instructions
 - Remove both doors, outside air knob, black knob and fascia. Place fascia on protected surface.
 - Remove the six center bricks from the bottom of the fireplace.
 - Remove the two screws from the access panel in the firebox floor. See Figure 4.8. Pry up panel with screwdriver and remove panel.

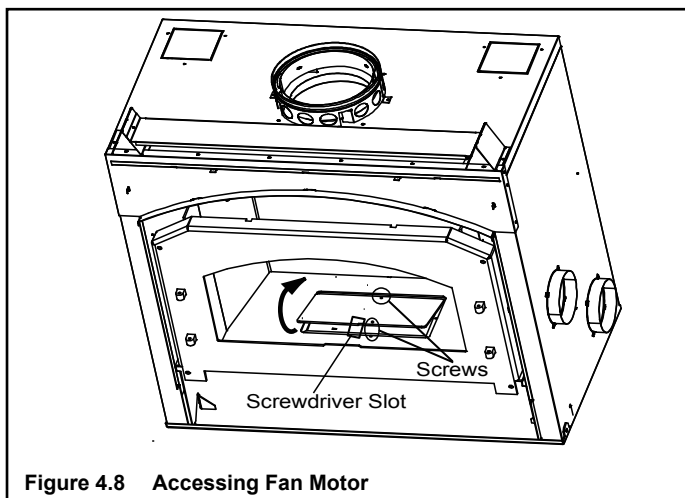

Figure 4.8 Accessing Fan Motor

- Removing the fan
 - Unplug the wire harness.
 - Lift fan from locating pins and remove (Figure 4.9). Repeat for second fan if necessary.
 - Connect new fan wires to wire harness.
 - Before installing the fan, make sure the grommets are tightly in place. Insert the right fan and place over the two locating pins. Repeat for other fan. Figure 4.10
 - Re-install bottom panel or firebox access panel in reverse order as described above.
 - Replace the brick that was removed.
 - Re-install the fascia and both knobs.
 - Re-install both doors and hinge pins.
 - Reconnect the power.

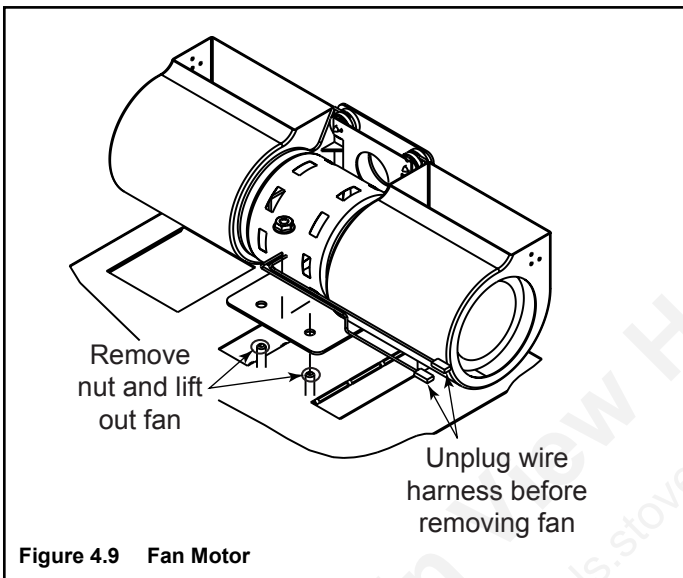

Figure 4.9 Fan Motor

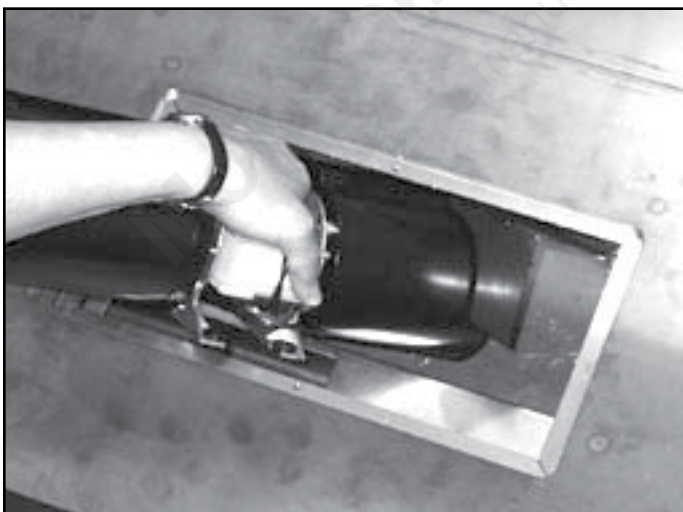

Figure 4.10 Installing Fans

6. Timer Assembly Replacement

CAUTION! Risk of Shock! Disconnect power by turning off circuit breaker BEFORE servicing.

- Remove both doors, outside air knobs, fascia, and brick.
- Remove two Phillips head screws and pry open access door in the bottom of the fireplace with a flat head screwdriver. See Figure 4.11.

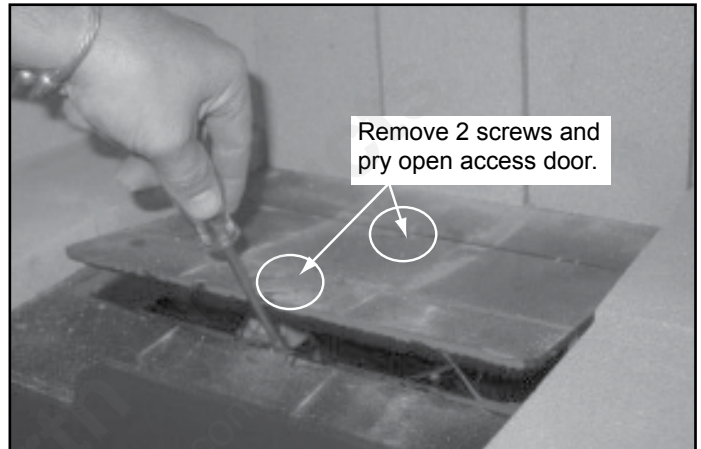

Figure 4.11 Open Access Door

- Remove two screws and take off access cover shown in Figure 4.12.

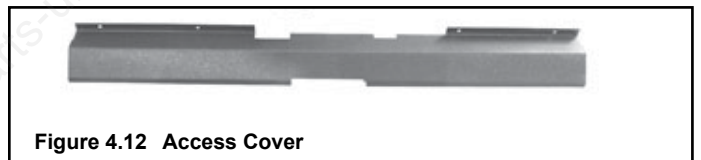

Figure 4.12 Access Cover

NOTICE: The timer assembly included in this kit comes with the air chamber cover attached (Figure 4.13).

- You will need to disconnect air chamber cover from timer assembly before installing in the fireplace. Set screws aside for later use. See Figure 4.14 .

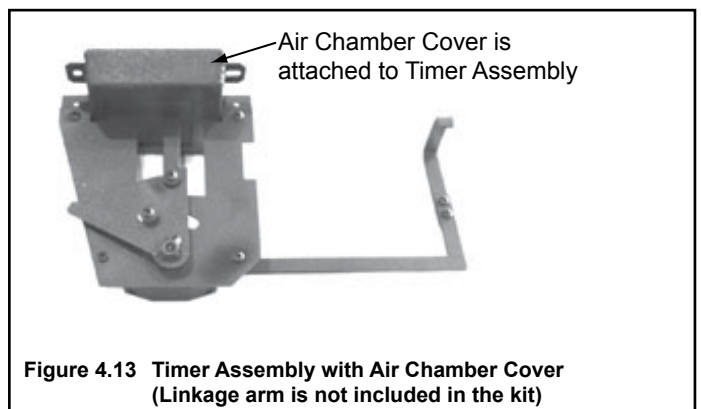

Figure 4.13 Timer Assembly with Air Chamber Cover (Linkage arm is not included in the kit)

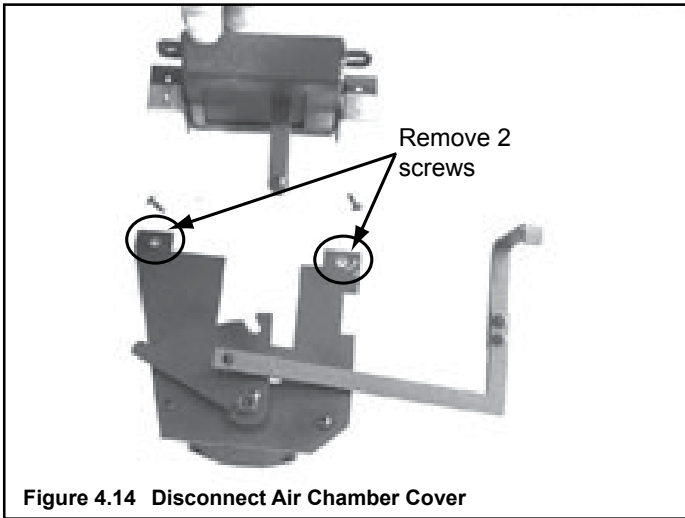

Figure 4.14 Disconnect Air Chamber Cover

- Remove two screws from timer linkage upper arm. Be careful NOT TO DROP arm in bottom of fireplace. See Figure 4.15

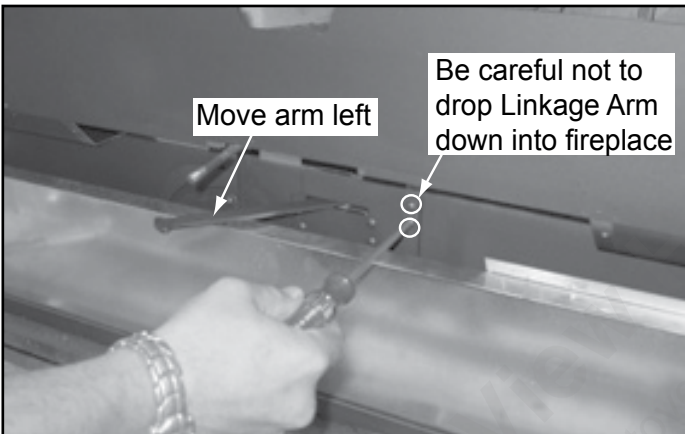

Figure 4.15 Remove Upper Arm

- Remove two screws from timer mounting plate (Figure 4.16). Place your hand into the access door (Figure 4.17) in the floor of the fireplace. Let the timer assembly and plate drop down and rotate it up through the access door. You will be looking at the back side of the assembly. See Figure 4.18.

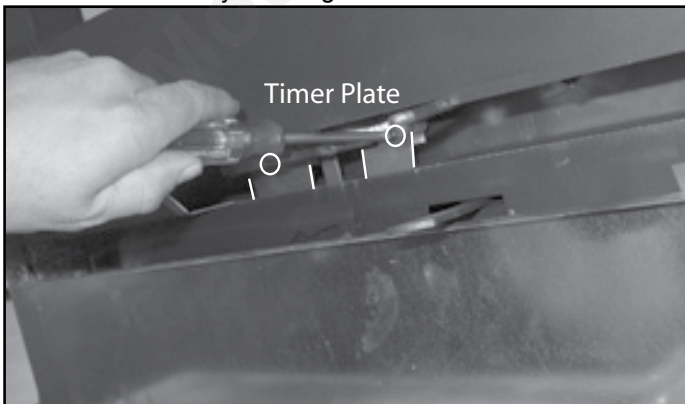

Figure 4.16 Remove Screws from Timer Mounting Plate

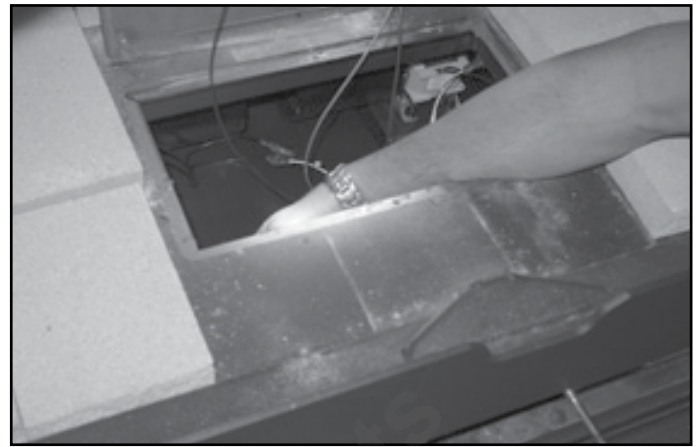

Figure 4.17 Hand in Access Door

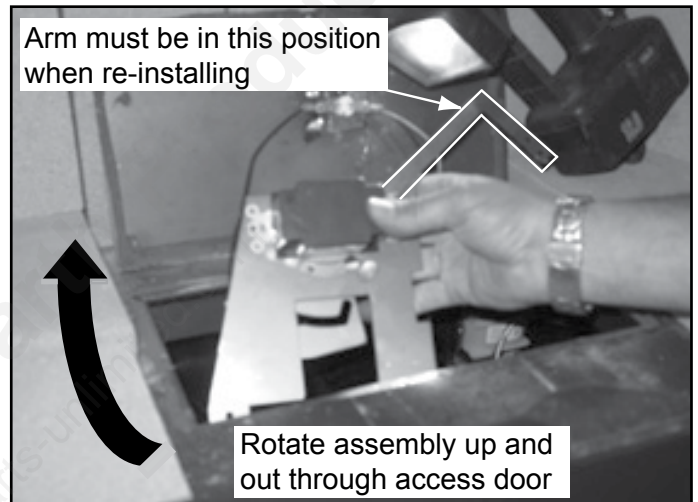

Figure 4.18 Removing Timer Assembly

- Remove old air chamber cover. Place the cover under the bottom of the firebox. Using a 7/16 wrench attach the two 1/4-20 bolts as shown in Figure 4.19.
- If installing a new timer, skip to 4.B.7 Timer Removal & Replacement, install timer, return to here.
- Insert the new timer assembly into the access door with the back side towards you. Please note the correct position of the linkage lower arm in Figure 4.18.

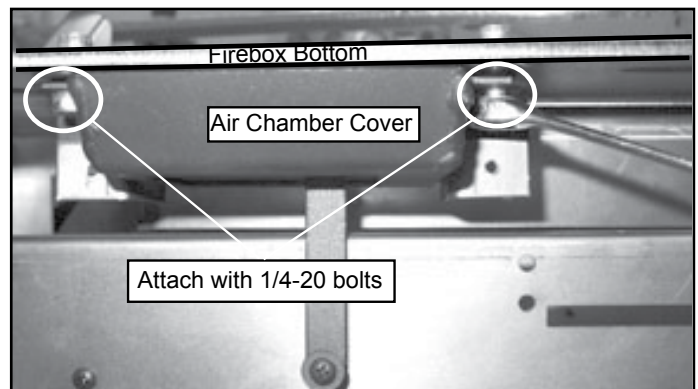

Figure 4.19 Install Control Box

- After re-installing the timer assembly through the firebox access door, re-attach the timer assembly to the air chamber cover using a Phillips head screw driver. See Figure 4.19.
- Attach the linkage upper arm to the lower linkage arm.

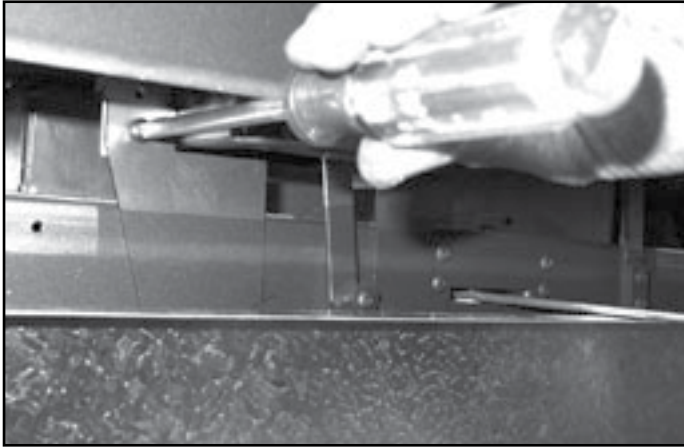

Figure 4.20 Timer Box Installed

- Install new timer using same two screws. It is very important that the D cut side of the timer shaft is facing the opposite side of the linkage timer arm. See Figure 4.22.

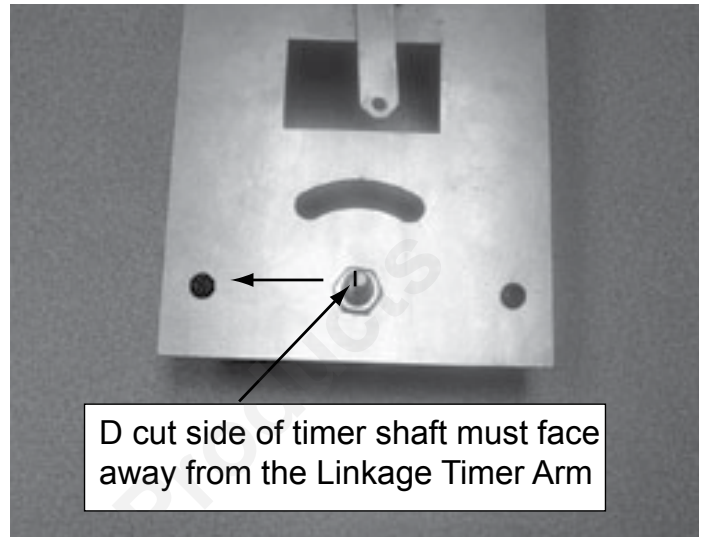

Figure 4.22 D Cut on Shaft

7. Timer Removal & Replacement

- Loosen set screw on timer, remove two screws and remove timer. See Figure 4.21.

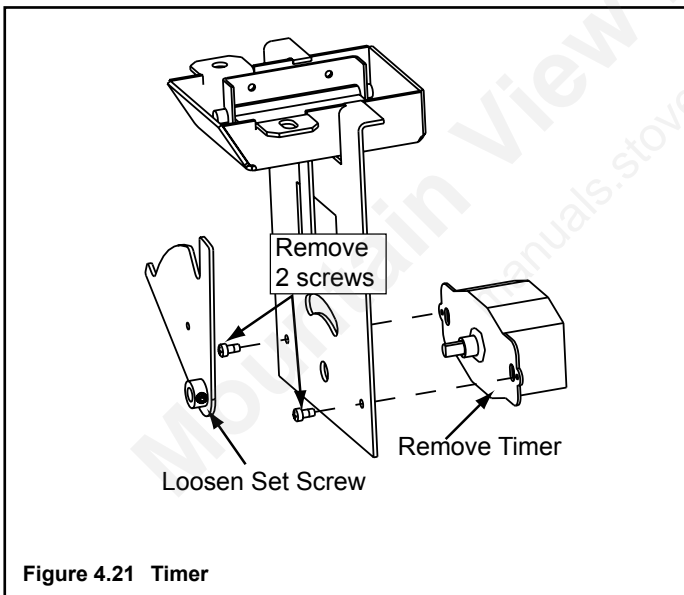

Figure 4.21 Timer

- Place linkage control arm over timer shaft and tighten set screw, Figure 4.23.

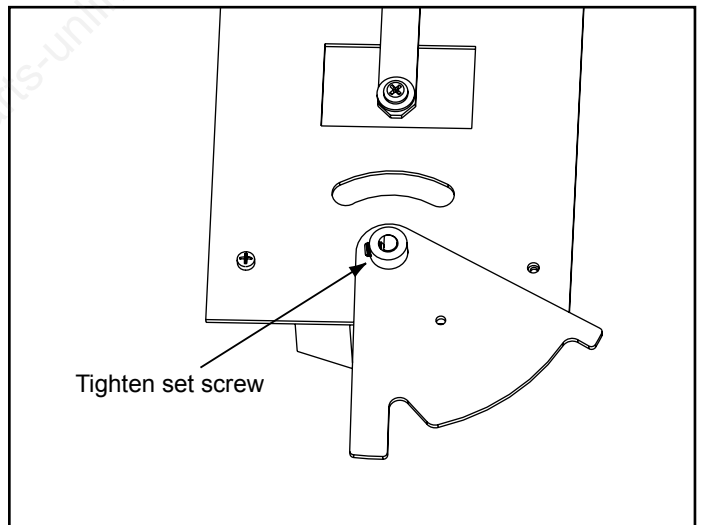
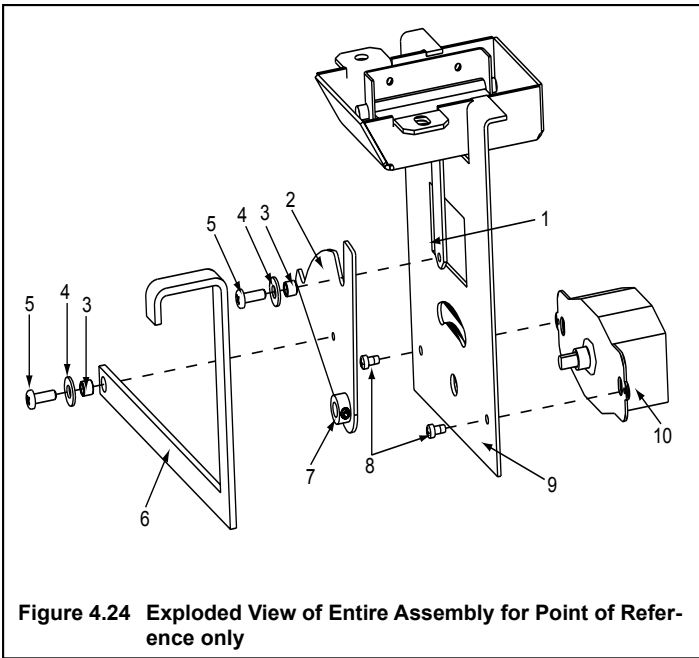

Figure 4.23 Linkage Control Arm Installed

- Rotate linkage control arm into final position and re-attach to mounting plate. Note that the D cut is now facing the linkage timer arm. Re-attach the linkage timer arm, Figure 4.23.
- Return to Timer Assembly Replacement, Section 4.B.6.



Item	Description	Qty
1	Door Linkage	1
2	Linkage Control Arm	1
3	Bushing	2
4	Washer SAE #10	2
5	Screw 8-32 x 1/2 PH PHL TC	2
6	Linkage Timer Arm	1
7	Attachment Nut & Set Screw	1
8	Screw 6-32 x 1/4 PH PHL TC	2
9	Mounting Bracket	1
10	Timer, Mechanical, 12 hours	1

5 Troubleshooting

A. FAQs

Hearth & Home Technologies assumes no responsibility for the improper performance of the fireplace system caused by inadequate draft due to environmental conditions, down drafts, tight sealing construction of the structure, or mechanical exhausting devices which will create a negative air pressure within the structure where the fireplace is located.

If smoke spillage occurs from a fireplace opening when the door is open, there is either a leakage in the flue, a blockage in the flue, or some condition is affecting draft. Understanding and differentiating the conditions which can cause each of these kinds of spillage problems is essential to their solution.

- **Flue Leakage**
Check for improperly connected flue joints or a damaged flue joint in the chimney system. Such leakage would reduce draft (air would be drawn in through the leaks rather than through the fireplace). The result might be difficult start-up and smoky fires that might spill if other adverse draft conditions accompany this problem.
- **Flue Blockage**
The damper should be open.
Check for objects that may have fallen down the chimney.

Flue draft is measured as negative pressure in the chimney. The amount of negative pressure determines how strong the draft is. The draft is important because it draws the combustion air into the fireplace and pulls the smoke out of the chimney.

There are three basic criteria essential in establishing and maintaining flue draft:

- availability of combustion air
- heat generated from the fire
- diameter and height of the flue system

These three factors work together as a system to create the flue draft. Increasing or decreasing any one of them will affect the other two and thus change the amount of draft in the entire system.

If the fire is hard to start and smoke spills out of the fireplace, or you find it difficult to establish and maintain a moderately high burn rate, then the flue draft is too low and corrective measures must be taken.

Be sure you have air available for combustion and that your firewood is dry and well seasoned. Build your fires properly and according to the instructions given in op-

erating instructions, "Starting a Fire". Be sure your flue system is installed correctly and that it is the proper diameter and height. Check for the following:

- All chimney sections are properly installed.
- The chimney is clean and free of creosote or soot buildup.
- Make sure overhanging trees and branches are cut back within ten feet of the top of the chimney and the chimney is free of debris from animals.
- Ensure the chimney cap is clean and free of any buildup of soot or creosote if cap is equipped with a spark arrestor screen.
- Be sure the ceramic blanket (above the baffle) and the baffle are in their proper positions
- The wood being used is dry and well seasoned.

If you still suspect you have a low draft problem it may be necessary to increase the volume of air in your flue system. Since the diameter of your flue system is matched with the size of the flue collar and should not be changed, then the height of the system must be increased. Add chimney sections one at a time until the draft improves.

In some cases, regardless of what you do, it can still be difficult to establish the proper flue draft. This is especially evident when using an exterior factory-built chimney or exterior masonry chimney. Try holding a burning rolled up newspaper as close to the flue outlet as possible for a few minutes, then light the paper under the kindling. The heat generated from the burning rolled up newspaper should help get the draft established.

Still other factors can affect how well your flue system performs. Neighboring structures, high winds, tall trees, even hillsides can affect air currents around the chimney. Well designed chimney caps are available that can help. Your fireplace dealer is the local expert in your area. He can usually make suggestions or discover problems that can be easily corrected allowing your fireplace to operate correctly as it has been designed, providing safe and economical heat for your home.

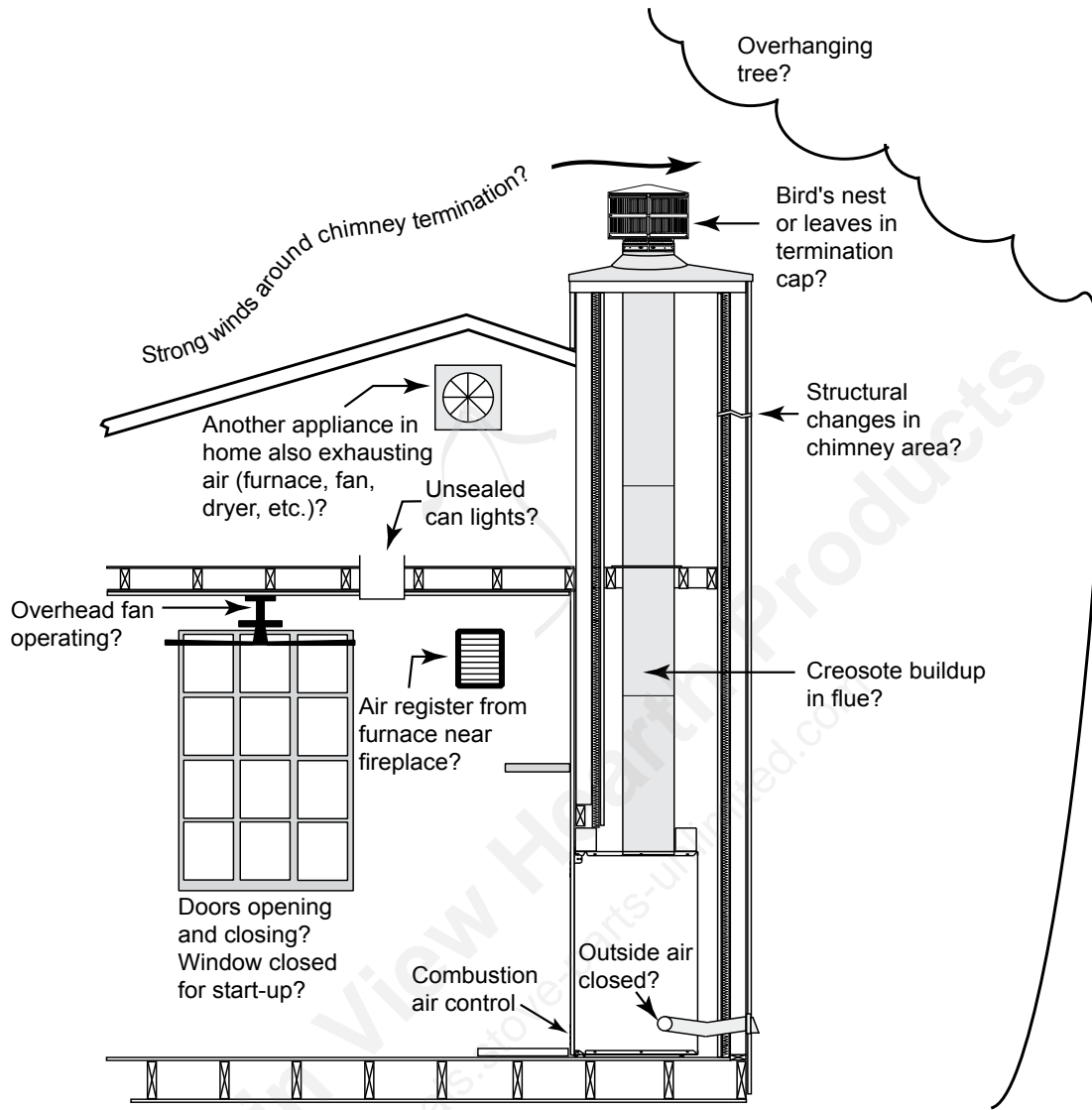

Figure 5.1 Factory-built Fireplaces: Troubleshooting

B. Troubleshooting Table

Fire is difficult to start	• Refer to section 4.C. Lighting Instructions
	• Open air controls
	• Establish draft: Hold a lighted, rolled up newspaper under the front of the baffle
	• Place DRY kindling over wadded up newspaper; leave air spaces between pieces of wood
	• Light the paper, allow kindling to ignite and progress to a lively burn
	• Slowly add progressively larger pieces of dry wood until the fire is well established
Smoke in the house at startup	• Check and clean chimney if needed
	• Open air controls
	• Establish draft
	• Do not use exhaust fans during startup
	• Do not close doors until the fire is well-established
Smoke in the house during operation	• Check and clean chimney if needed
	• Check door rope for seal
	• Open air controls (ACC)
Smoke in the house during refueling	• Open air controls (ACC) to establish a lively coal bed
	• Open doors SLOWLY
	• Add progressively larger wood to establish a hot fire
Fuel burns too fast	• ACC not working properly
	• Wood too dry, mix in less seasoned wood after the fire is established
	• User larger diameter wood
	• Check baffle/ceramic blanket for proper placement (Section 3.A.3)
	• Close down ACC (refer to section 4.D. Heat Management)
Glass doesn't stay clean	• Establish a good, hot fire
	• Use well-seasoned wood
Not enough or no heat	• Move combustion air control to fully open position
	• Fan is not on
	• Insufficient fuel for fire/heat required
Fan doesn't come on	• No power
	• Fireplace is not hot enough to activate snap disc
	• Snap disc may be faulty

6 Reference Materials

► A. Service Parts

HEAT & GLO™

No one builds a better fire

Service Parts

Woodburning Fireplace

NORTHSTAR

Beginning Manufacturing Date: Mar 2002

Ending Manufacturing Date: Active

Northstar-BK, Black (Feb 2003-Active), Northstar-NT, Nickel (July 2004- Active)
Northstar-GD, Gold (May 2003 -Apr 2004), Northstar-GT, Gold Trim (July 2004-Sept 2007)

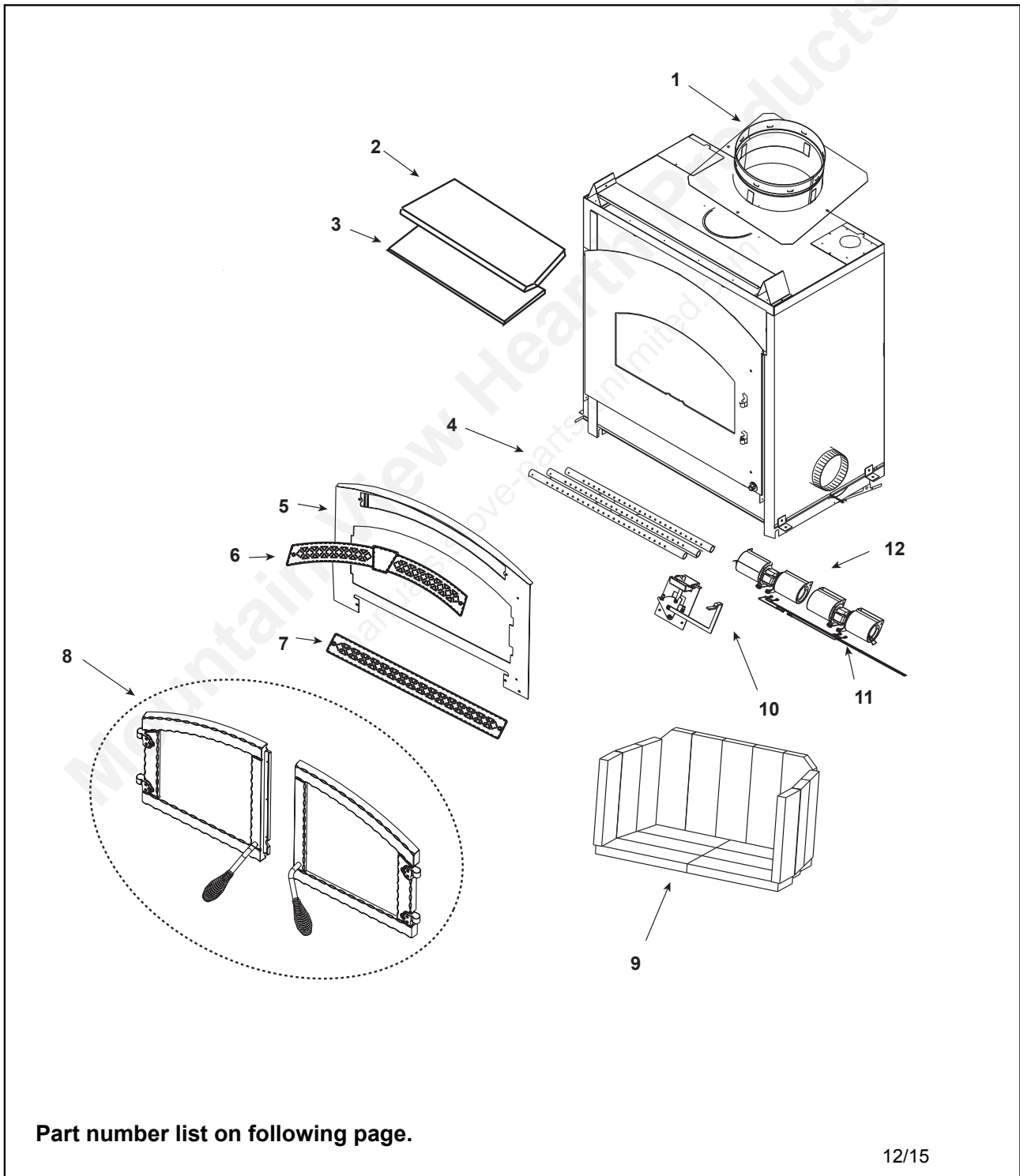

No one builds a better fire

Beginning Manufacturing Date: Mar 2002

Ending Manufacturing Date: Active

IMPORTANT: THIS IS DATED INFORMATION. Parts must be ordered from a dealer or distributor. **Hearth and Home Technologies does not sell directly to consumers.** Provide model number and serial number when requesting service parts from your dealer or distributor.

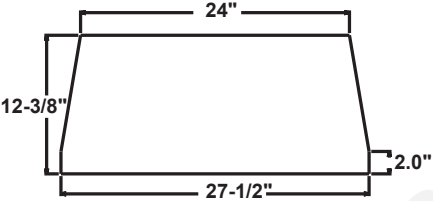
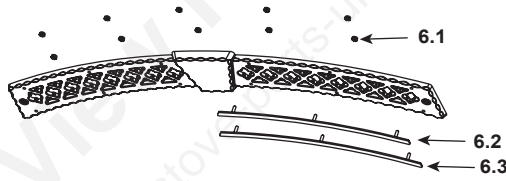
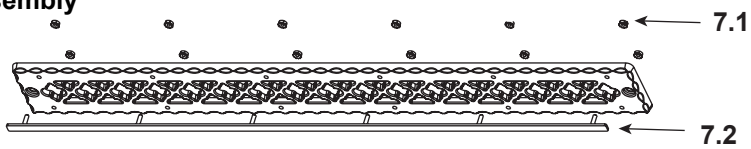

Stocked at Depot

ITEM	DESCRIPTION	COMMENTS	PART NUMBER	
1	Starter Plate Assembly		SL1	
	8 in Starter Section		22069B	Y
#2 Ceramic Blanket 				
2	Ceramic Blanket		480-0760	
3	Baffle, Fiberboard		SRV480-0510	Y
4	Manifold Tubes	Set of 3	TUBES-480	Y
	Manifold Clip Screws	Pkg of 4	832-0661	Y
5	Fascia, Plate only	Black Only	FASCIA-NS	
	Screw, 1/4-20 x 1.25 Button Head, Black Oxide	Pkg of 8	4021-816/8	
#6 Top Louver Assembly 				
6	Louver Top	Black, No Trim	SRV480-7100	
		Gold	482-5320	
		Nickel	480-5380	
6.1	Nut, 8-32, Keps	Pkg of 40	226-0060/40	Y
6.2	Louver Trim, Upper	Gold	480-1710	
		Nickel	480-1830	
6.3	Louver Trim, Lower	Gold	480-1720	
		Nickel	480-1840	
#7 Bottom Louver Assembly 				
7	Louver Bottom	Black, No Trim	SRV480-7090	
		Gold	450-5310	
		Nickel	480-5370	
7.1	Nut, 8-32, Keps	Pkg of 40	226-0060/40	Y
7.2	Louver Trim, Bottom	Gold	480-1700	
		Nickel	480-1820	

Additional service part numbers on following page.

No one builds a better fire

Beginning Manufacturing Date: Mar 2002
Ending Manufacturing Date: Active

#8 Door Assembly

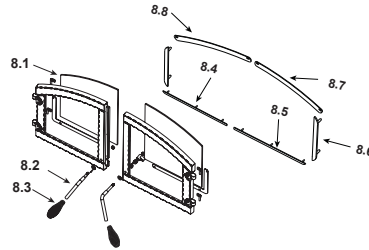

IMPORTANT: THIS IS DATED INFORMATION. Parts must be ordered from a dealer or distributor. **Hearth and Home Technologies does not sell directly to consumers.** Provide model number and serial number when requesting service parts from your dealer or distributor.



Stocked at Depot

ITEM	DESCRIPTION	COMMENTS	PART NUMBER	
8	Door Assembly, Black, (A whole neew door must be ordered to change the color of the trim	Pre 0071533828	480-5010	
		Post 0071533828	SRV480-5460	
	Door Assembly, Nickel, (A whole neew door must be ordered to change the color of the trim	Pre 0071533825	480-5330	
		Post 0071533825	SRV480-5480	
	Door Assembly, Gold, (A whole neew door must be ordered to change the color of the trim	Pre 0071533825	480-5270	
		Post 0071533825	N/A	
	Door Gasketing, 1/2 in.		SRV433DRGASKET	Y
	Gasket, Lytherm, 1/2 x 1/8, 4.	4.17 Ft	834-2590	
	Door Hinges, Right Hand	Pkg of 4	480-2110/4	Y
	Door Hinges, Left hand	Pkg of 4	480-2120/4	Y
	Screw, 8 x 32 x 3/8	Pkg of 40	225-0500/40	Y
	Washer, 3/8 SAE,	3 ea	832-0990	Y
8.1	Glass Assembly	Qty 2 req	480-5430	Y
	Glass Gasketing, 1/4 in	10 Ft	834-1460	Y
	Glass Frame Bottom		480-1450	
	Glass Frame Top		480-1440	
8.2	Handle Assembly		HANDLES-480	
	Includes 2 door handles, securing bracket, lock nut, latch cam key and cam latch			
	Cam Latch		32084	
	Cam Latch Key, 5/8 in		430-1151	
	Door Handle	Left	SRV480-0530	
		Right	SRV480-0520	
8.3	Spring Handle, 1/2" Gold	Pkg of 2	832-0620	Y
	Spring Handle, 1/2" Nickel	Pkg of 1	250-8330	Y
8.4	Door Trim Bottom, Left (Only use for damaged as a replacement for damaged parts)	No longer available	480-1680	
		Nickel	480-1800	
8.5	Door Trim Bottom, Right (Only use for damaged as a replacement for damaged parts)	No longer available	480-1670	
		Nickel	480-1790	
8.6	Door Trim Top, Left (Only use for damaged as a replacement for damaged parts)	No longer available	480-1660	
		Nickel	480-1780	
8.7	Door Trim Top, Right (Only use for damaged as a replacement for damaged parts)	No longer available	480-1650	
		Nickel	480-1770	
8.8	Door Trim Top, Side (Only use for damaged as a replacement for damaged parts)	No longer available	480-1690	
		Nickel	480-1810	

No one builds a better fire

Beginning Manufacturing Date: Mar 2002
Ending Manufacturing Date: Active

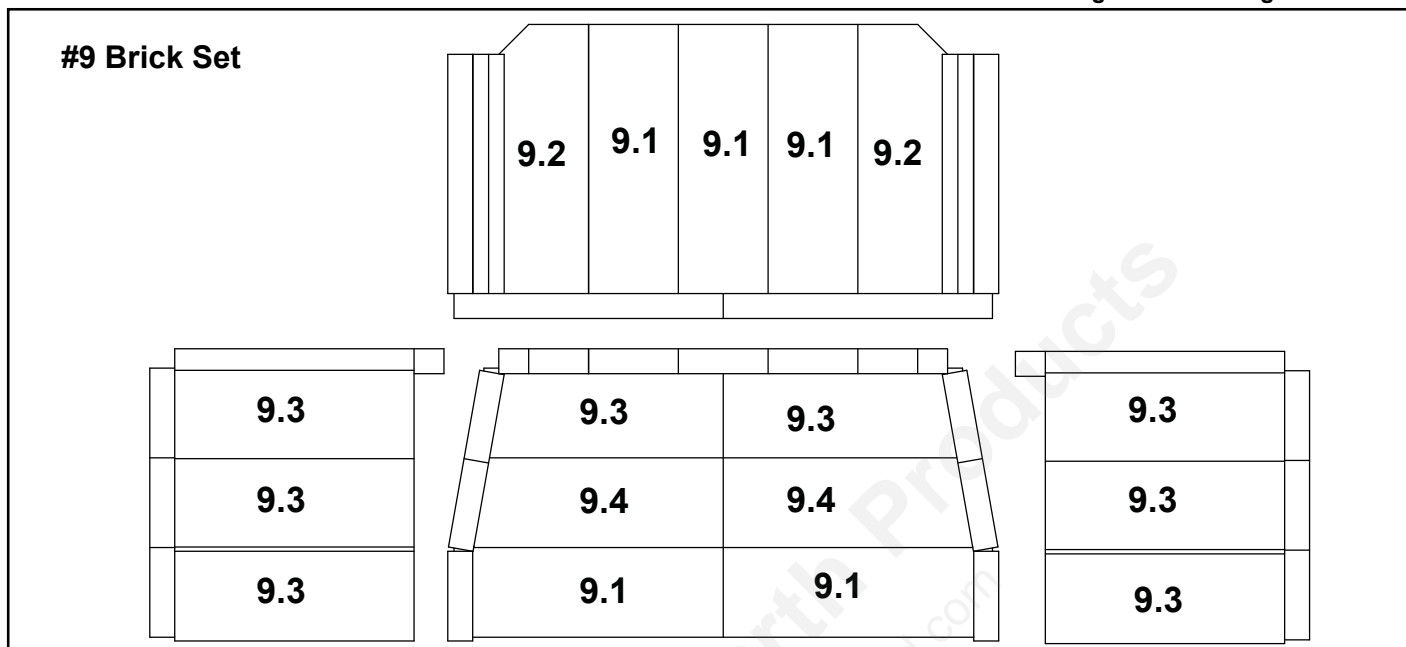

IMPORTANT: THIS IS DATED INFORMATION. Parts must be ordered from a dealer or distributor. **Hearth and Home Technologies does not sell directly to consumers.** Provide model number and serial number when requesting service parts from your dealer or distributor.



Stocked at Depot

ITEM	DESCRIPTION	COMMENTS	PART NUMBER	
9	Brick Set		BRICK-480	
9.1	Brick, 13-1/4" x 4-1/2" x 1-1/4"	Qty 5 req	SRV7000-306	
9.2	Brick, 13-1/2" x 4-1/2" x 1-1/4", With 1-1/2" Chamfer	Qty 2 req	480-2270	
9.3	Brick, 12" x 4-1/2" x 1-1/4"	Qty 8 req	480-2280	
9.4	Brick 12-1/2" x 4-1/2" x 1-1/4"	Qty 2 req	480-2290	
10	Timer Assembly		SRV480-5150	Y
	Gasket, Timer		480-1240	
	Timer		SRV480-1940	Y
	Screw, 8-32 x 1/2" (Assembly includes qty. of 2)	Pkg of 25	220-0030/25	Y
	Washer (Assembly includes qty. of 2)	Pkg of 25	227-0080/25	Y
11	Wiring Harness		SRV480-0990	Y
12	Blower Assembly w/Bracket	Pre 0091535936	812-4900	Y
		Post 0091535936	SRV433-5890	Y

Protection Channel

Side view

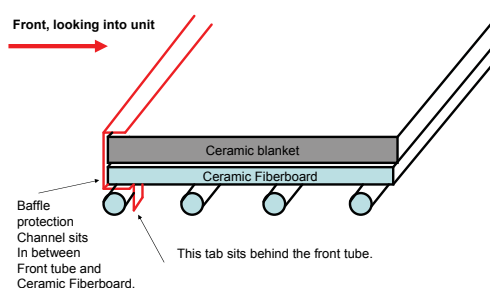

13	Baffle Protection Panel		480-2100	
----	-------------------------	--	----------	--

Additional service part numbers on following page.

No one builds a better fire

Beginning Manufacturing Date: Mar 2002
Ending Manufacturing Date: Active

IMPORTANT: THIS IS DATED INFORMATION. Parts must be ordered from a dealer or distributor. **Hearth and Home Technologies does not sell directly to consumers.** Provide model number and serial number when requesting service parts from your dealer or distributor.



**Stocked
at Depot**

ITEM	DESCRIPTION	COMMENTS	PART NUMBER	
	Access Assembly		433-6270	
	Chimney Air Kit		CAK4A	
	Face Board Assembly, Non-combustible board		480-5440	Y
	Facia Template		HHT-Template	
	Fan Speed Control		SRV7000-143	Y
	Fire Screen		MESH-HHT	Y
	Header Shield		480-1130	
	Hearth Strip		18320	
	Knob Black , Outside Air		7000-246	Y
	Latch Magnet		229-0631	
	Light Switch		480-1260	
	Light Switch Cover Plate		480-1270	
	Lintel Bar		LINTELBAR-HHT	
	Manual Bag Assembly, Includes owner's manual, 1 spring handle-1/4 in, fan switches & cover plate, warranty card and touch-up paint.	Black or Gold (No Handles)	SRV480-1140	
		Nickel (Includes Handles)	SRV480-1950	
	Outer Can cover Plate		480-1300	
	Outside Air Hood 6"		4059-051	
	Outside Air Shield		33271	Y
	Slider Control Assembly		480-5410	
	Snap Disc Bracket		410-2521	
	Snap Disc, F220-160F		SRV480-1730	Y
	Snap Disc, F180F-150, (for use with Uninsulated Chases)		SRV4021-827	
	Spring Handle, 1/2 in, Black	Pkg of 1	SRV7000-613	Y
	Spring Handle, 1/4 in, Black	Pkg of 1	SRV7000-614	Y
	Spring Handle, 1/4 in, Gold	Pkg of 1	832-0630	Y
	Spring Handle, 1/4 in, Nickel	Pkg of 1	250-8340	Y
	Stand Off, Top		480-1040	
	Touch Up Paint	Black	812-0910	
	Unit Collar		659-125	
	Adhesive, Hi Temp		7000-298	
Fastener Packs				
	AVK Repair Kit 1/4-20		RIVNUT-REPAIR	Y
	Screw, 1/4-20 x 5/8	Pkg of 24	220-0440/24	Y
	Screw, HWH MS 1/4-20 x 3/4	Pkg of 25	220-0080/25	Y
	Screw, PH 8-32 x 1/2	Pkg of 25	220-0030/25	Y
	Washer, 1/4 SAE	Pkg of 24	28758/24	Y

This page intentionally left blank.

Mountain View Hearth Products
manuals.stove-parts-unlimited.com

This page intentionally left blank.

Mountain View Hearth Products
manuals.stove-parts-unlimited.com

C. Contact Information





No one builds a better fire

Heat & Glo, a brand of Hearth & Home Technologies
1915 West Saunders Street
Mount Pleasant, Iowa 52641

Please contact your Heat & Glo dealer with any questions or concerns.

For the number of your nearest Heat & Glo dealer, please visit www.heatnglo.com.

- NOTES -

CAUTION		
	DO NOT DISCARD THIS MANUAL	
<ul style="list-style-type: none">• Important operating and maintenance instructions included.	<ul style="list-style-type: none">• Read, understand and follow these instructions for safe installation and operation.	<ul style="list-style-type: none">• Leave this manual with party responsible for use and operation.

This product may be covered by one or more of the following patents: (United States) 5613487, 5647340, 5890485, 5941237, 6006743, 6019099, 6053165, 6145502, 6374822, 6484712, 6601579, 6769426, 6863064, 7077122, 7098269, 7258116, 7470729, 8147240 or other U.S. and foreign patents pending.

2000-945C