

Models:
WS-150
WS-250

Installers Guide



This manual contains instructions for:
• Installation • Operation • Maintenance

- PLEASE READ ALL OF THE OWNERS MANUAL AND SAFETY NOTES -

IMPORTANT SAFETY NOTES:

1. When installing your stove, particular attention should be paid to fire protection. If this unit is not properly installed, a house fire may result. For your safety, follow the installation instructions and contact local building or fire officials about restrictions and installation inspection requirements in your area.
2. Never use gasoline or similar liquids to start a fire in this unit. Keep all such liquids well away from stove.
3. During operation, if any part of the stove starts to glow, the stove is in an overfired condition. Close the air controls completely until the glowing has stopped. OVERFIRING VOIDS WARRANTY.
4. Cool ashes should be disposed of carefully, using a metal container.
5. Do not burn wet or green wood. Store wood in dry location.
6. Do not burn garbage, treated wood, or wood with salt (driftwood, etc.). Burning materials other than wood (including charcoal) under adverse conditions may generate carbon monoxide in the home, resulting in illness or possible death.
7. Do not permit creosote or soot to accumulate excessively in the chimney or inside the firebox.
8. Check your chimney system thoroughly when installing into an existing metal or masonry chimney. Seek professional advice if in doubt about its condition.
9. Do not connect this unit to a chimney flue already serving another appliance.
10. Comply with all minimum clearances to combustibles as shown in this manual for this appliance.
11. Build fire on brick firebox floor. Do not use grates, andirons or other methods to support fuel.
12. HOT WHILE IN OPERATION. Keep children, pets, clothing and furniture away. Contact can cause skin burns.
13. Do not connect to any air distribution duct or system.
14. RISK OF FIRE! Do not operate with stove door open.
15. For further information refer to NFPA 211 (U.S.) or CAN/CSA-B365 (Canada).
16. **WARNING:** WHEN ASSEMBLING APPLIANCE, USE ONLY HEAT-N-GLO PRODUCTS MANUFACTURED COMPONENTS. USE OF ANY OTHER COMPONENTS WILL VOID YOUR WARRANTY AND COULD PRESENT A SERIOUS SAFETY HAZARD.
17. **WARNING:** DO NOT OPERATE YOUR WS-150 or WS-250 STOVE BEFORE FULLY ASSEMBLING ALL COMPONENTS.

FOR FUTURE REFERENCE

ATTACH YOUR SALES RECEIPT HERE

- NOTES -

Serial No.:

Date Purchased:

Dealership Where Purchased:

Dealer Phone No.:

Mountain View Hearth Products
manuals.stove-parts-unlimited.com

TABLE OF CONTENTS

DIMENSIONS	4
CLEARANCES TO COMBUSTIBLES	6
SAFETY LISTING	7
INSTALLATION MATERIALS NEEDED	7
VENTING SYSTEM	7
CHIMNEY CONNECTOR	8
CHIMNEY HEIGHT/DRAFT	8
CONNECTION TO A MASONRY CHIMNEY	8
INSTALLATION USING MASONRY OR BRICK CHIMNEY	11
CONNECTION TO A METAL PREFABRICATED CHIMNEY	13
DOOR INSTALLATION	14
MOBILE HOME INSTALLATION	15
LEG KIT INSTALLATION	15
OUTSIDE AIR KIT	16
OPTIONAL BLOWER	17
ASH REMOVAL SYSTEM	18
OPERATING INSTRUCTIONS	19
Burning process	19
Primary and secondary air systems	19
Wood selection and storage	20
Overfiring	20
Building a fire	20
Burning guidelines	21
MAINTENANCE	22
Creosote	22
Care and cleaning of glass	22
Chimney cleaning	22
Ash removal	22
Firebrick	22
GLASS REPLACEMENT	23
DOOR HANDLE ASSEMBLY	23
BAFFLE REMOVAL AND INSTALLATION	24
BRICK INSTALLATION	25
ACCESSORIES AND SERVICE PARTS	26
WARRANTY	27

DIMENSIONS OF MODELS WS-150 AND WS-250 WITH PEDESTAL

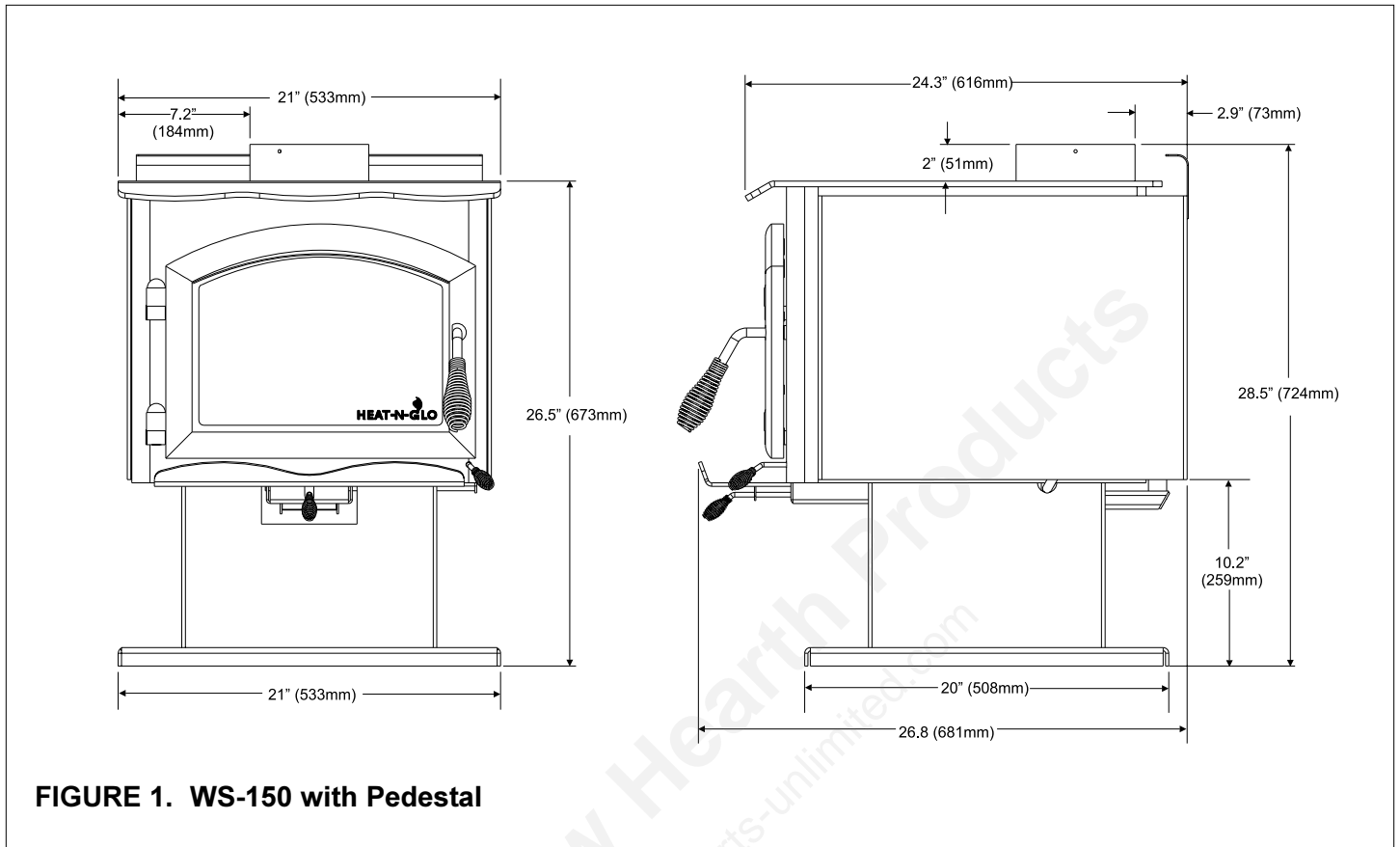

FIGURE 1. WS-150 with Pedestal

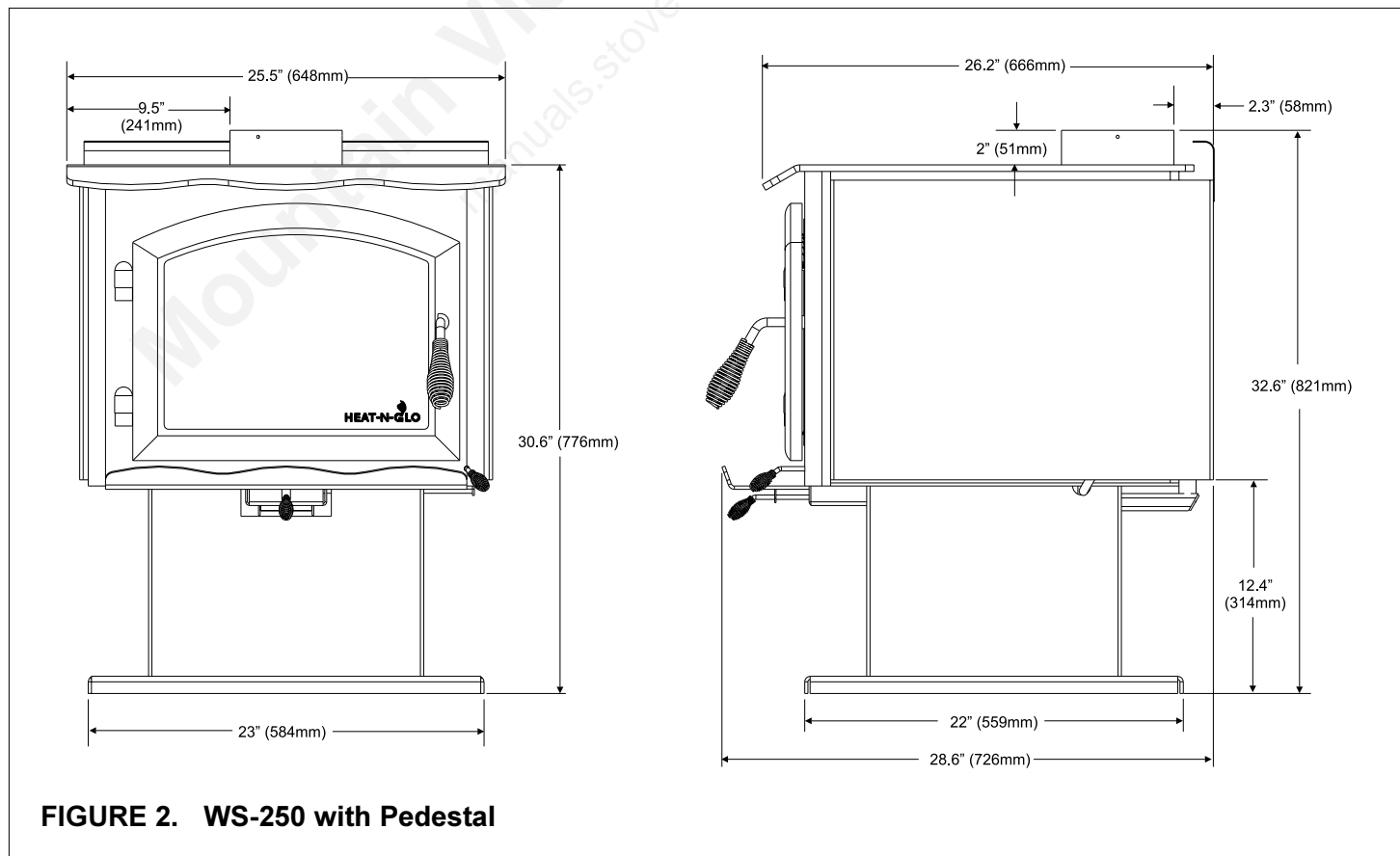
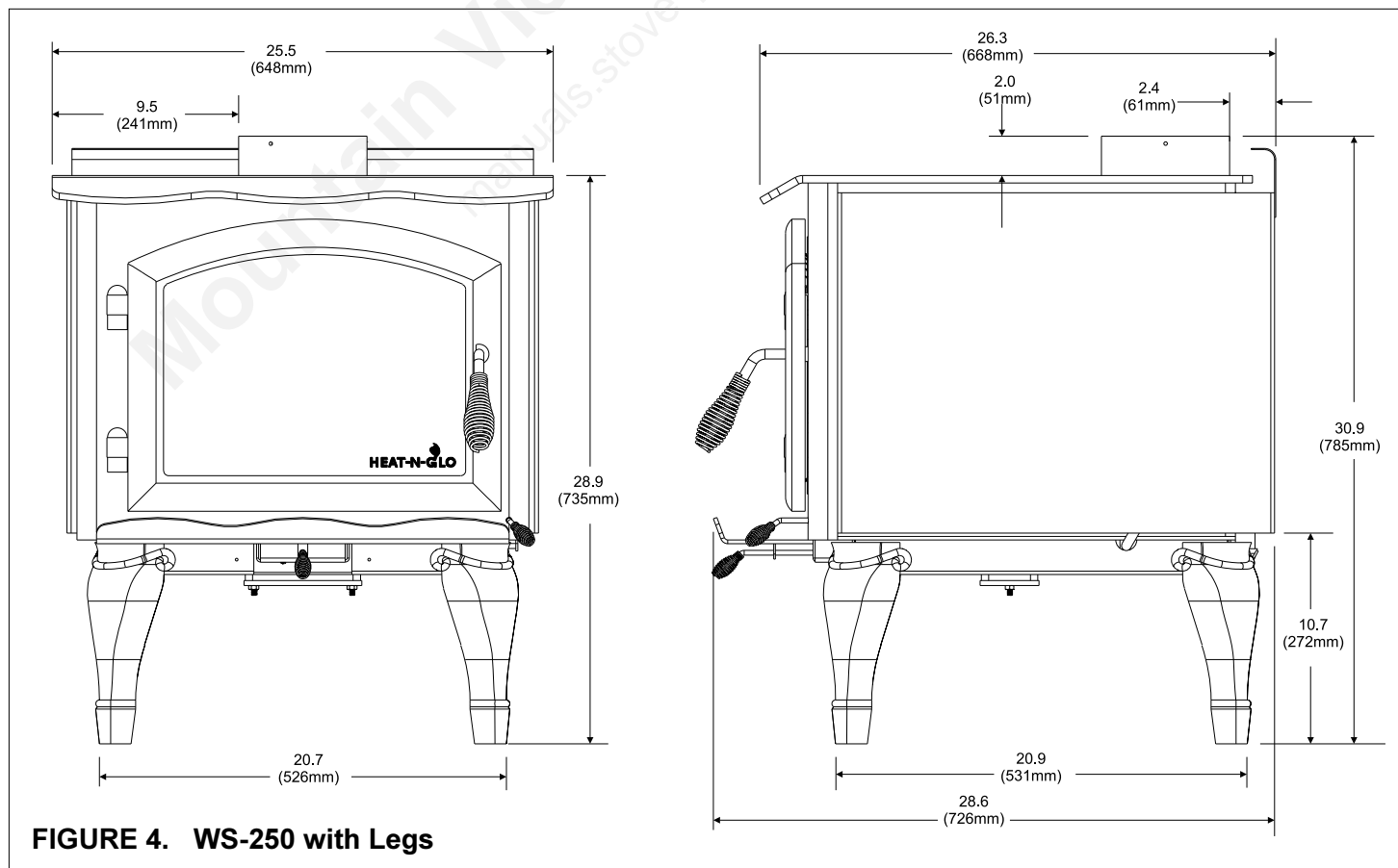
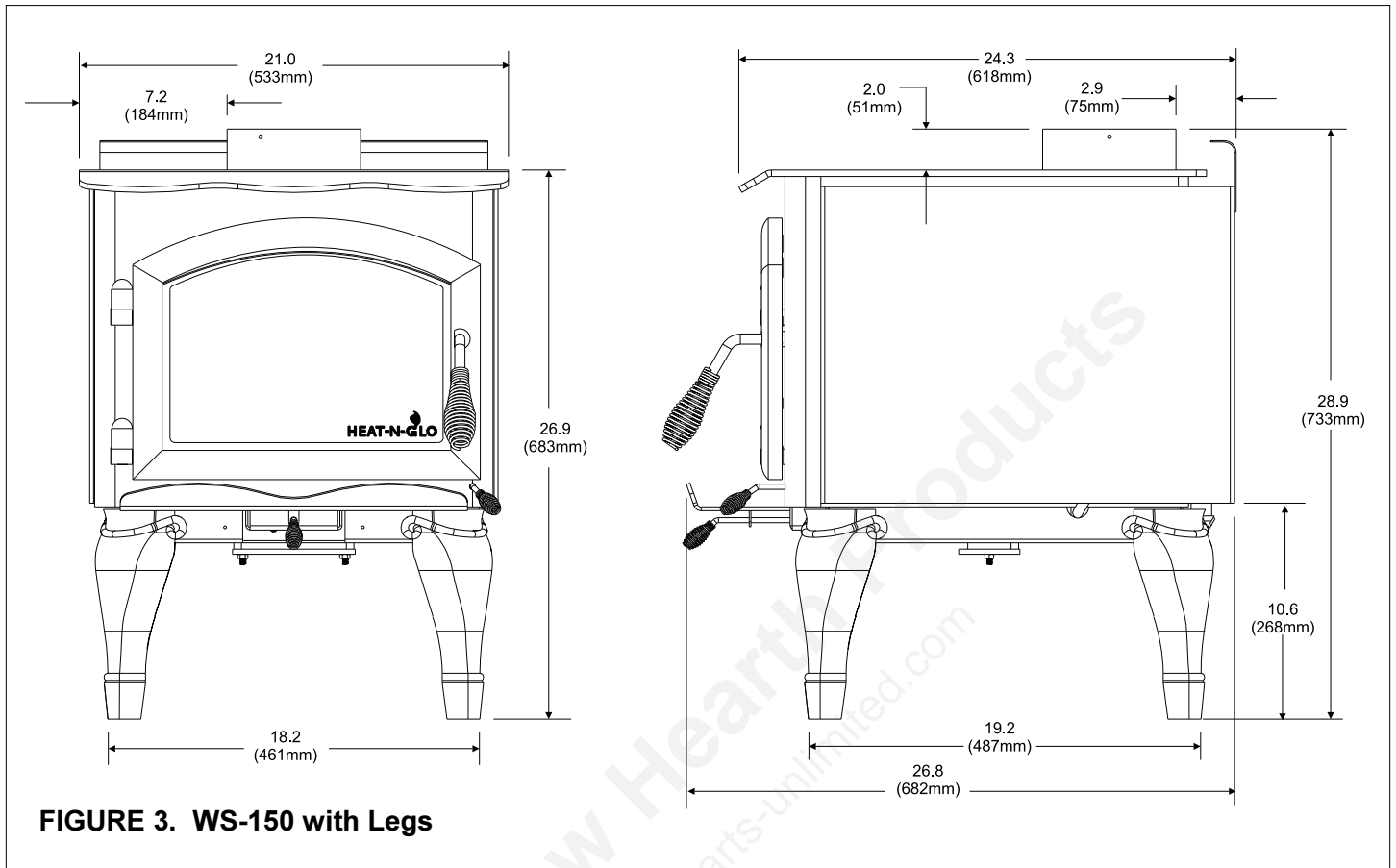

FIGURE 2. WS-250 with Pedestal

DIMENSIONS OF MODELS WS-150 AND WS-250 WITH LEGS



CLEARANCES TO COMBUSTIBLES

Floor protector must be 3/8" (10mm) thick minimum noncombustible material or equivalent, extending beneath heater and to the front/sides/rear as indicated in the "Floor Protection" (See Figure 5).

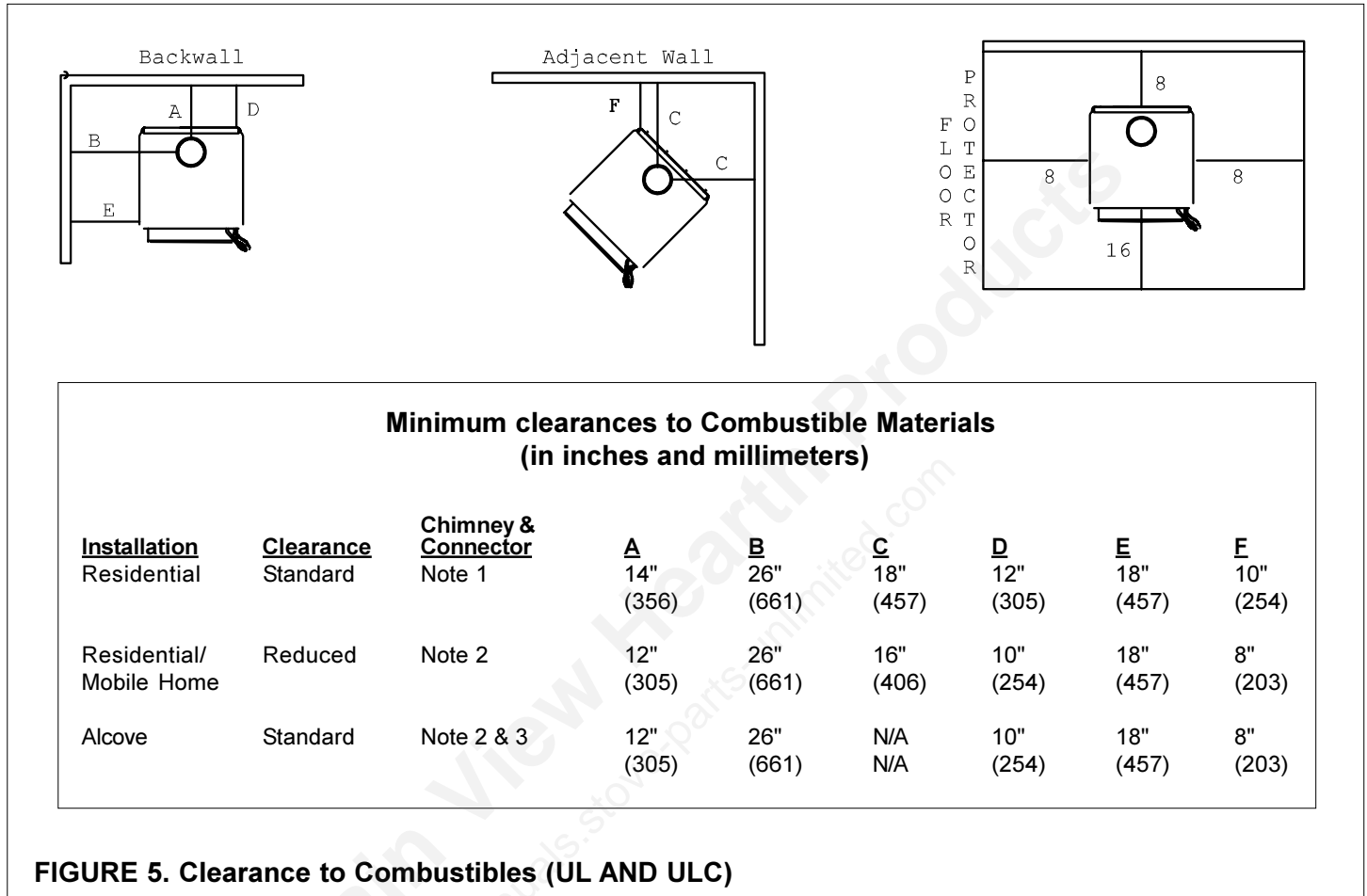

FIGURE 5. Clearance to Combustibles (UL AND ULC)

Note 1: 6" (152mm) diameter single wall, minimum 24 MSG black or blued steel connector pipe with a listed factory-built type HT chimney suitable for use with solid fuels or a masonry chimney.

Note 2: 6" (152mm) diameter double wall air cooled connector pipe with listed factory-built type HT chimney or a masonry chimney. (Mobile home venting system must be equipped with a rain cap and spark arrestor.) For installations with a preexisting class A chimney system, a listed stainless steel chimney liner should be installed, or the existing chimney examined by a chimney sweep for acceptable further use.

Note 3: Alcove specifications: Maximum depth of alcove shall be no more than 48" (1219mm). For additional alcove information and clearances, refer to clearances to combustibles above.

NOTE: Unit is approved for use with listed double wall air-insulated chimney connector or elbows.

When locating your stove consider safety, convenience, traffic flow, and the fact that the stove will need a chimney and chimney connector.

NFPA 211: Use a noncombustible material with 1" (25mm) ventilated air space to reduce clearances. However, this is not to exceed 50% of WS-150's (or WS-250's) specified clearances.

NOTE: Must follow NFPA 211 spacing and materials to qualify. It is also subject to local jurisdiction.

AVOID FIRE: Maintain the designated clearances to combustibles. Insulation must not touch the chimney. You must maintain the designated air space clearance around the chimney. This space around a chimney is necessary to allow natural heat removal from the area. Insulation in this space will cause a heat buildup, which may ignite wood framing.

SAFETY LISTING

The WS-150 AND WS-250 are approved for mobile home installations with outside combustion air in the U.S. (See page 14 for further details). For residential installations in Canada without an outside combustion air kit, a source of fresh air into the room must be provided.

INSTALLATION MATERIALS NEEDED FOR YOUR SAFETY

CHIMNEY CONNECTOR (also known as flue pipe or stove pipe): The chimney connector joins the stove to the chimney (see page 11). It should be 6" (152mm) minimum diameter 24 MSG black or blued steel, or an approved air-insulated double wall venting pipe.

THIMBLE: A manufactured or site-constructed device installed in combustible walls through which the chimney connector passes to the chimney (see pages 11-12). It is intended to keep the walls from igniting.

CHIMNEY SYSTEMS

- A. APPROVED MASONRY (see specifications on pages 12-13) with at least 5/8" (16mm) fire clay lining joined with refractory cement or other listed system suitable for use with wood stoves.
- B. PREFABRICATED 6" (152mm) listed high temperature (UL 103HT or ULC 629M) chimney. Components required by manufacturers for installation such as the chimney support base, firestop (as appropriate), attic insulation shield, insulated tee, etc., are necessary to assure a safe chimney installation. Use only components manufactured for the chimney. Chimney installation should meet NFPA 211 standards.

FIRE SAFETY: To provide reasonable fire safety, the following should be given serious consideration:

1. Install at least one smoke detector on each floor of your home to ensure your safety. They should be located away from the heating appliance and close to the sleeping areas. Follow the smoke

detector manufacturer's placement and installation instructions, and be sure to maintain regularly.

2. A conveniently located Class A fire extinguisher to contend with small fires resulting from burning embers.
3. A practiced evacuation plan, consisting of at least two escape routes.
4. A plan to deal with a chimney fire as follows: In the event of a chimney fire:
 - A. Notify fire department
 - B. Prepare occupants for immediate evacuation.
 - C. Close all openings into the stove.
 - D. While awaiting fire department, watch for ignition of adjacent combustibles from overheated stove pipe, hot embers or sparks from the chimney.

VENTING SYSTEM

The venting system consists of a chimney connector and a chimney. These get extremely hot during use. In the event of a creosote fire, temperatures inside the chimney may exceed 2000°F (1100°C). To protect against the possibility of a house fire, the chimney connector and chimney must be properly installed and maintained. An approved thimble must be used when a connection is made through a combustible wall to a chimney. A chimney support package must be used when a connection is made through the ceiling to a prefabricated chimney. These accessories are absolutely necessary to provide safe clearances to combustible wall and ceiling material. Follow venting manufacturer's clearances when installing venting system.

This stove may be connected to a lined masonry chimney or a listed high temperature prefabricated approved metal chimney. Do not connect it to a chimney serving another appliance. To do so will affect the safe operation of both appliances.

CHIMNEY CONNECTOR

The chimney connector must be 6" (152mm) diameter with a minimum thickness of 24 gauge. Do not use aluminum or galvanized steel. They cannot properly withstand the extreme temperatures of a wood fire. Do not use chimney connector pipe as a chimney. You must connect your stove to a chimney comparable to those illustrated in this manual.

Chimney connector sections must be attached to the stove and to each other with the crimped end toward the stove (see Figure 6). This allows creosote to run into the stove and not onto the outside of the pipe. Attach the chimney connector to the flue collar with three sheet metal screws. All joints should also be secured with three sheet metal screws. Otherwise, in the event of a creosote fire, the connector may vibrate apart.

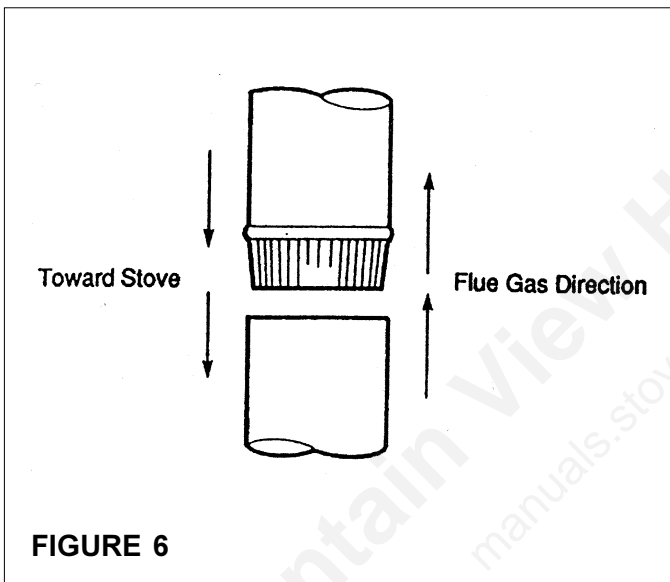

FIGURE 6

For proper operation, the chimney connector should be as short as possible. Horizontal lengths of chimney connector should have a minimum upward slope from the stove of at least $\frac{1}{4}$ " per foot.

CHIMNEY HEIGHT/DRAFT

To insure that the stove burns properly, the chimney draft (static pressure) should be approximately 0.1" water column (W.C.) during a high burn and .04" W.C. during a low burn, measured 6" (152mm) above the top of the stove after one hour of operation at each burn setting.

NOTE: These are guidelines only, and may vary somewhat for individual installations.

This stove was designed for and tested on a 6" (152mm) chimney, 12'-14' (3.66-4.27m) high,

measured from the top of the stove. The further your stack height or diameter varies from this configuration, the probability of performance problems increases. In addition, exterior conditions such as roof line, surrounding trees, prevailing winds and nearby hills can influence stove performance.

CONNECTION TO A MASONRY CHIMNEY

1. CHIMNEY:

Should the stove be connected to a masonry chimney, the chimney should be examined for cracks, loose mortar, or other signs of deterioration and blockage. The stove should not be installed until it is determined that the chimney is safe for use. Since an oversized flue contributes to the accumulation of creosote, the size of the flue should be checked to determine that it is not too large for the stove. The chimney should also be checked to insure it meets the minimum standards of the National Fire Protection Association (NFPA) Standard 211. Following is a list of the more critical minimum requirements for a properly constructed chimney.

The masonry wall of the chimney, if brick or modular block, must be a minimum of 4" (102mm) thick. A mountain or rubble stone wall must be at least 12" (305mm) thick.

The chimney must have a fire clay flue liner (or equivalent) with a minimum thickness of $\frac{5}{8}$ " (16mm) and must be installed with refractory mortar. There must be at least $\frac{1}{2}$ " (13mm) air space between the flue liner and the chimney wall (see Figure 7). An equivalent liner must be a listed chimney liner system or other approved material.

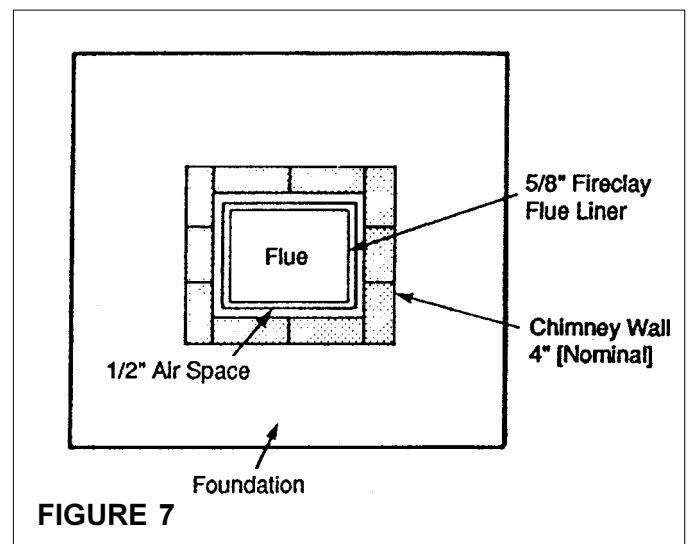
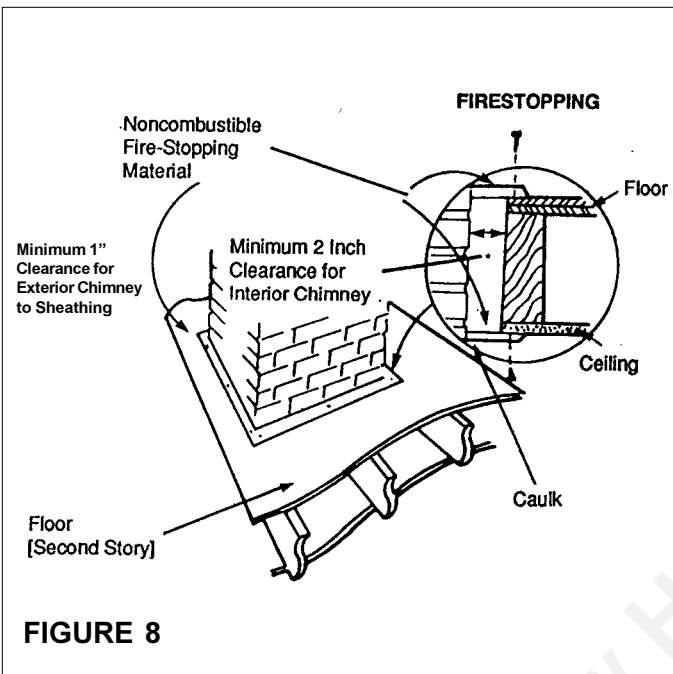
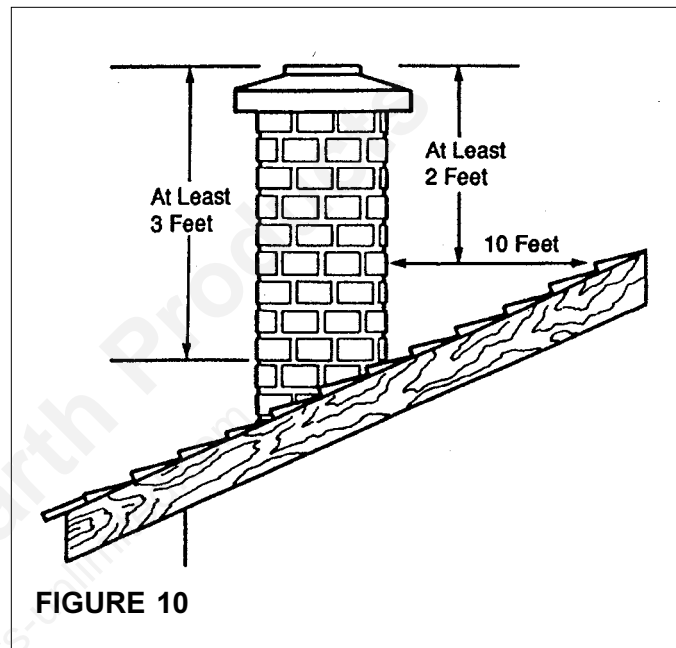

FIGURE 7

A chimney inside the house must have at least 2" (50mm) of clearance to the combustible structure. A chimney outside the house must have at least 1" (25mm) clearance to the combustible structure. Firestops must be installed in the spaces where the chimney passes through floors and/or ceiling (Figure 8).



A chimney must be the required height above the roof or other obstruction for safety and proper draft operation. The chimney must be a minimum of 3' (914mm) higher than the highest point where it passes through the roof, and at least 2' (610mm) higher than the highest part of the roof or structure that is within 10' (3048mm) of the chimney, measured horizontally (Figure 10).



Remember that insulation must not contact the chimney. There must be air space around the chimney. Insulation must be 2" (50mm) or more from the chimney (Figure 9).

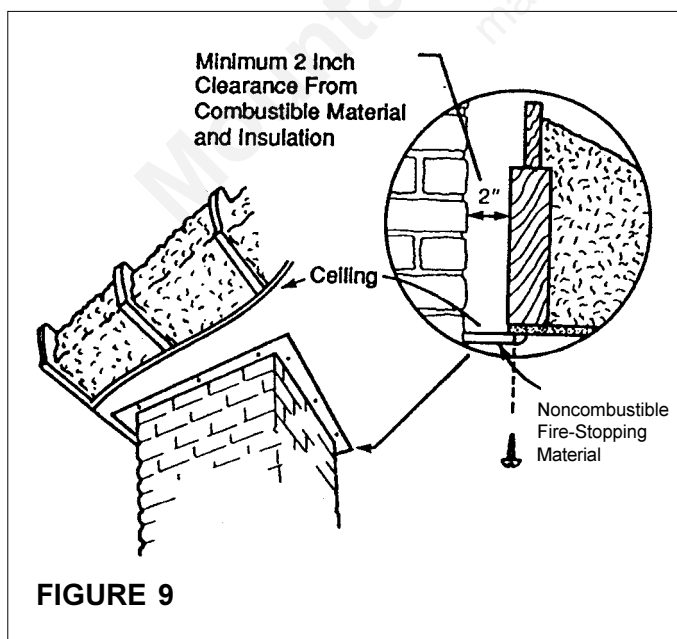

2. THIMBLE:

An approved thimble must be used when the connection from the stove is made through a combustible wall to a masonry chimney. There are several methods you can use for connection through a combustible wall, two of which are illustrated in this manual. For additional methods, consult local building authorities or use the standards set forth in NFPA 211.

Also, listed prefabricated metal thimbles are available for use with wood stoves. The manufacturer's installation for the thimbles must be strictly followed to assure the safety of the system. Be sure to maintain the designated clearances to combustible materials.

A. BRICK CHIMNEY THIMBLE ASSEMBLY:

Construction of the brick thimble assembly requires 12" (305mm) of brick around a fire clay liner. Be sure the point of penetration allows an 18" (457mm) clearance from the connector to the ceiling. For a 6" (152mm) chimney connector, an opening of 30" (762mm) must be cut in the wall to maintain the required 12" (305mm) of brick separation from combustibles. It will be necessary to cut wall studs and install a header and sill frame to maintain proper dimensions and to hold the weight of the brick (Figure 11).

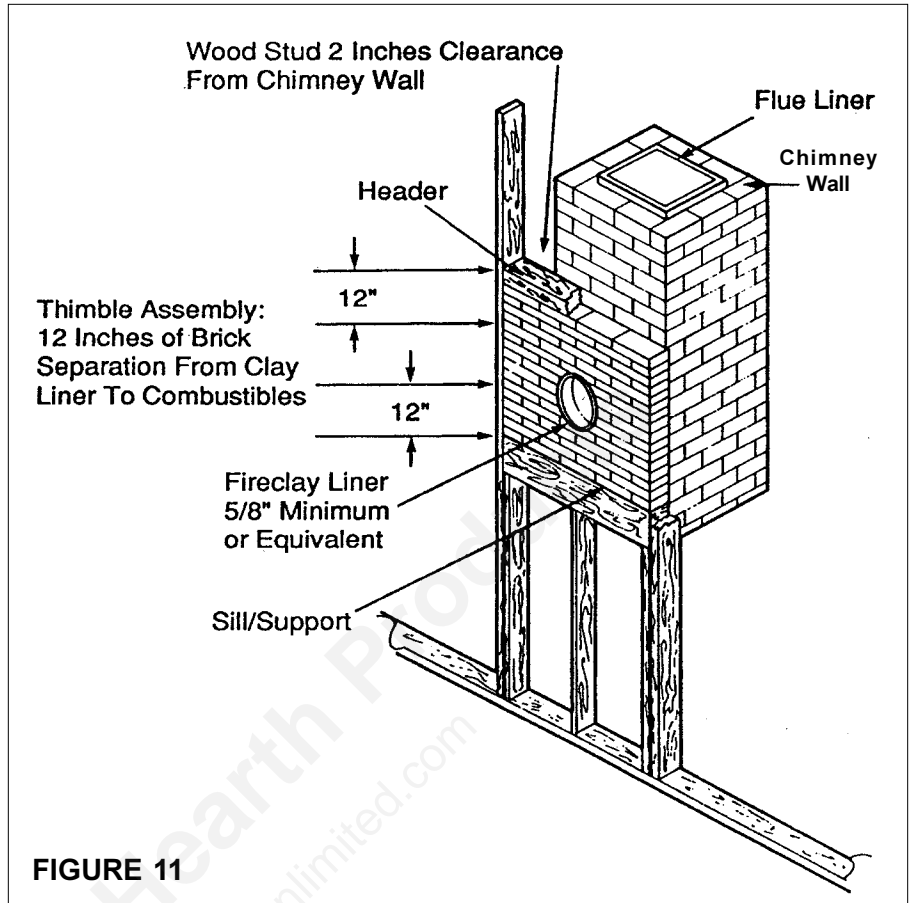

INSTALLATION USING MASONRY OR BRICK CHIMNEY

Minimum 3 1/2" (89mm) [4" (102mm) nominal] thick solid bricks are to be used. The fire clay liner (ASTM C35 or equivalent), 5/8" (16mm) wall thickness, must not penetrate into the chimney beyond the inner surface of the chimney flue liner and must be firmly cemented in place. If it is necessary to cut a hole in the chimney liner, use extreme care to keep it from shattering. Refractory mortar must be used at the junction with the chimney liner. After the assembly is complete, insert the chimney connector into the fire clay liner. Do not push it beyond the inside edge of the chimney liner, as this will affect the draw of the chimney.

B. 6" SOLID PACK CHIMNEY WITH METAL SUPPORTS AS A THIMBLE:

For the method of installation to a masonry chimney shown in Figures 13 and 14, it will be necessary to purchase a 6" (152mm) inside diameter, 12" (305mm) long section of prefabricated listed solid pack chimney to use as a thimble. Purchase a wall spacer, trim collar and wall band that are manufactured to fit the chimney section you purchase. Cut out a 14 1/2" (368mm) diameter opening in the wall. It may be necessary to cut wall studs and install a header and sill frame to maintain the wall support. The hole in the chimney must have at least a 6" (152mm) diameter fire clay liner or equivalent, secured with refractory mortar. If it is necessary to cut a hole in the chimney liner, use extreme care to keep it from shattering.

The safety features of this system are the 2" (50mm) air space between the chimney section and combustible wall and the 1" (25mm) air space around the chimney connector as it passes through the chimney section to the chimney. The location of the opening through the wall to the chimney must leave a minimum 18" (457mm) vertical clearance between the connector pipe and the ceiling, to prevent the ceiling from catching fire when using single wall pipe.

First, build the frame for the thimble, making sure that it is no smaller than 14 1/2" (368mm) diameter, which will maintain a 2" (50mm) air space around the chimney section. Attach the wall

spacer to the chimney side of the frame. Then insert the frame into the opening, toe-nailing it to the wall studs. Install the wall band in the framing to secure the chimney section in place. Insert a single section of chimney connector into the chimney through the wall band, being sure it does not protrude into the chimney beyond the edge of the chimney flue lining.

Apply high temperature furnace cement to the end of the chimney section and install it over the connector, through the wall band, and through the wall spacer. Tighten the wall band to hold the chimney section firmly in place and against the chimney. Install the trim collar on the outside of the opening.

Check to insure there is a 1" (25mm) air space between the connector and the chimney section. Also, during installation, always check to insure that a 2" (50mm) air space is being maintained to the wood framing. Do not fill this space with insulation. Insulation in this air space will cause a heat buildup which may ignite the wood framing.

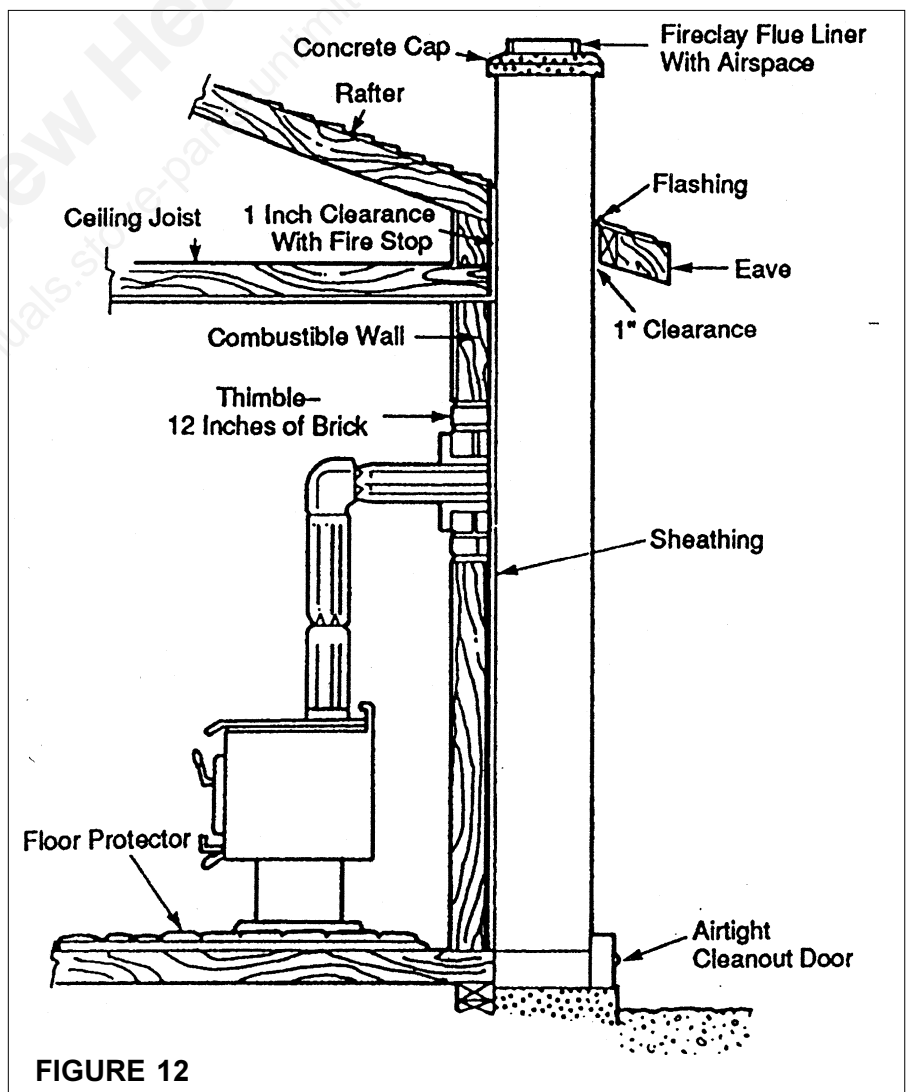
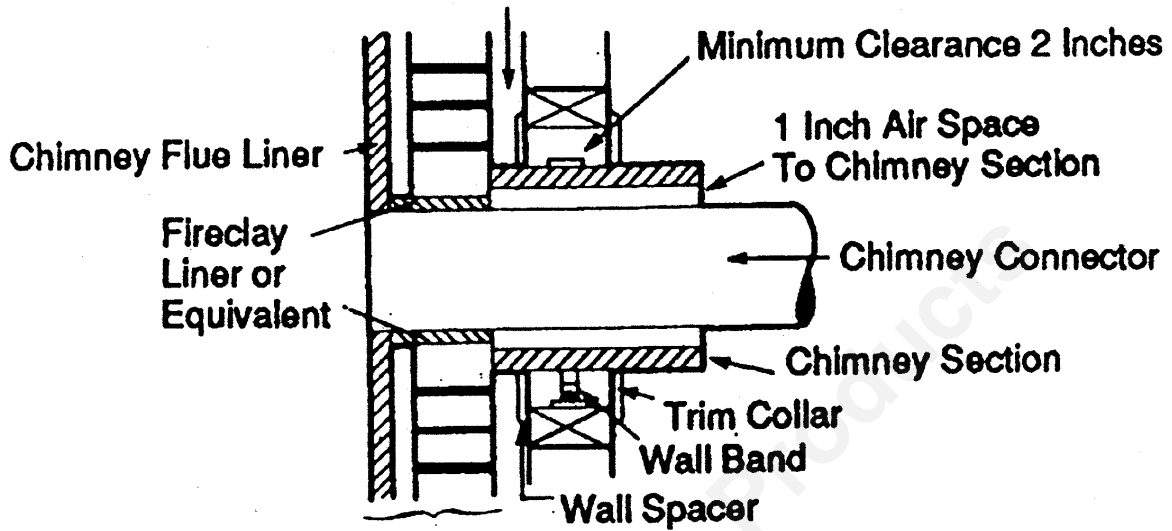

FIGURE 12

**Minimum Chimney Clearance
to Wall Spacer and
Combustibles 2 Inches**



**Masonry
Chimney Constructed
to NFPA 211**

FIGURE 13

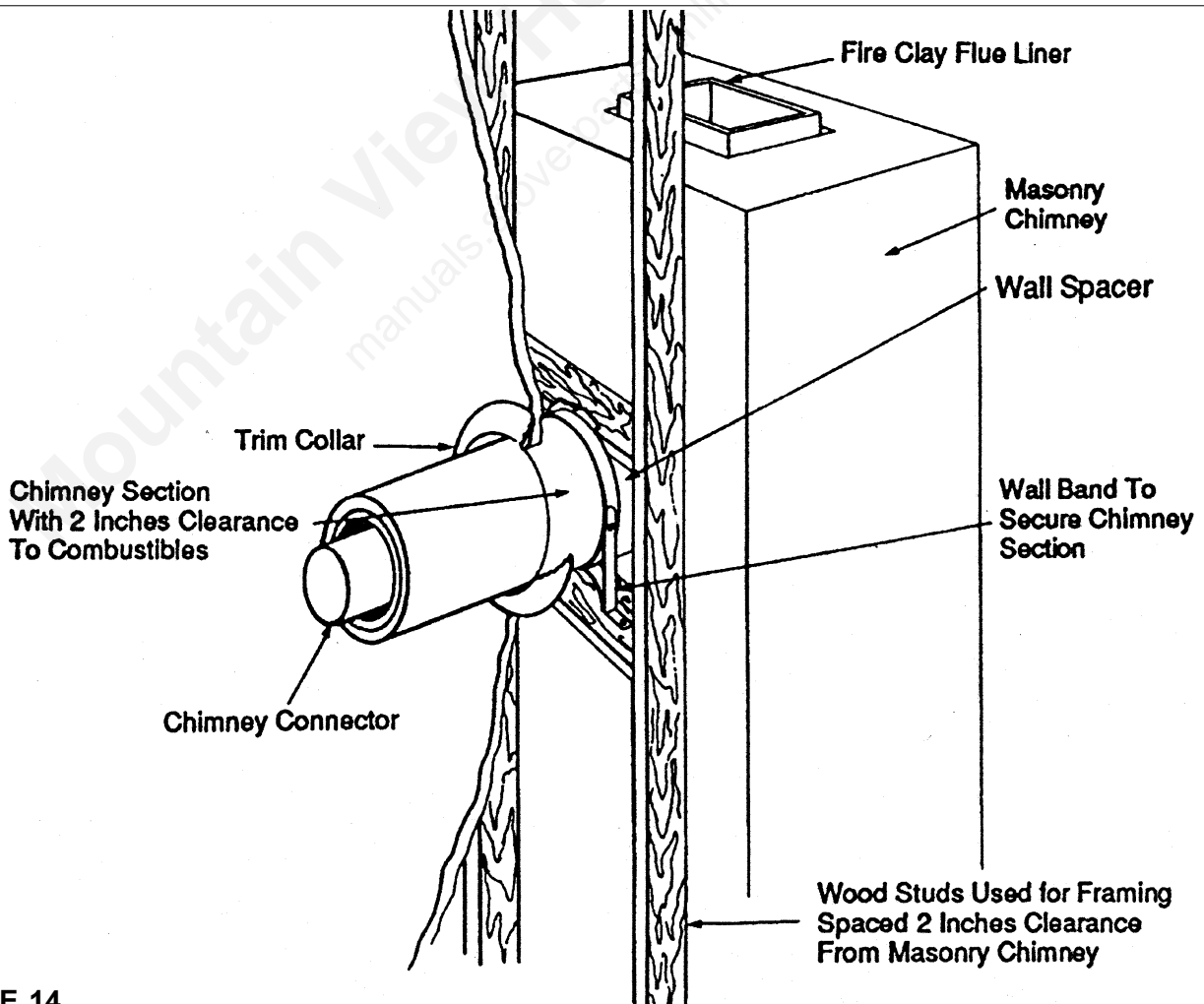

FIGURE 14

CONNECTION TO A METAL PREFABRICATED CHIMNEY

When a metal prefabricated chimney is used, the manufacturer's installation instructions must be followed precisely. You must also purchase (from the same manufacturer) and install the ceiling support package or wall pass-through and "T" section package, firestops (where needed), insulation shield, roof flashing, chimney cap, etc. Maintain the proper clearance to the structure as recommended by the manufacturer. This clearance is usually a minimum of 2" (50mm), although it may vary by manufacturer or for certain components.

There are basically two methods of metal chimney installation. One method is to install the chimney inside the residence through the ceiling and the roof (Figure 15). The other method is to install an exterior chimney that runs up the outside of the residence (Figure 16). This method of installation requires at a minimum a wall pass-through device, a wall support package, insulated "T" section and roof flashing. The components illustrated may not look exactly like the system you purchase, but they demonstrate the basic components you will need for a proper and safe installation.

The chimney must be the required height above the roof or other obstruction for safety and proper draft operation. The chimney must be a minimum of 3' (914mm) higher than the highest point where it passes through the roof, and at least 2' (610mm) higher than the highest part of the roof or structure that is within 10' (3048mm) of the chimney, measured horizontally (Figure 10).

REMEMBER: Follow the manufacturer's installation instructions and maintain the manufacturer's specified clearance distances.

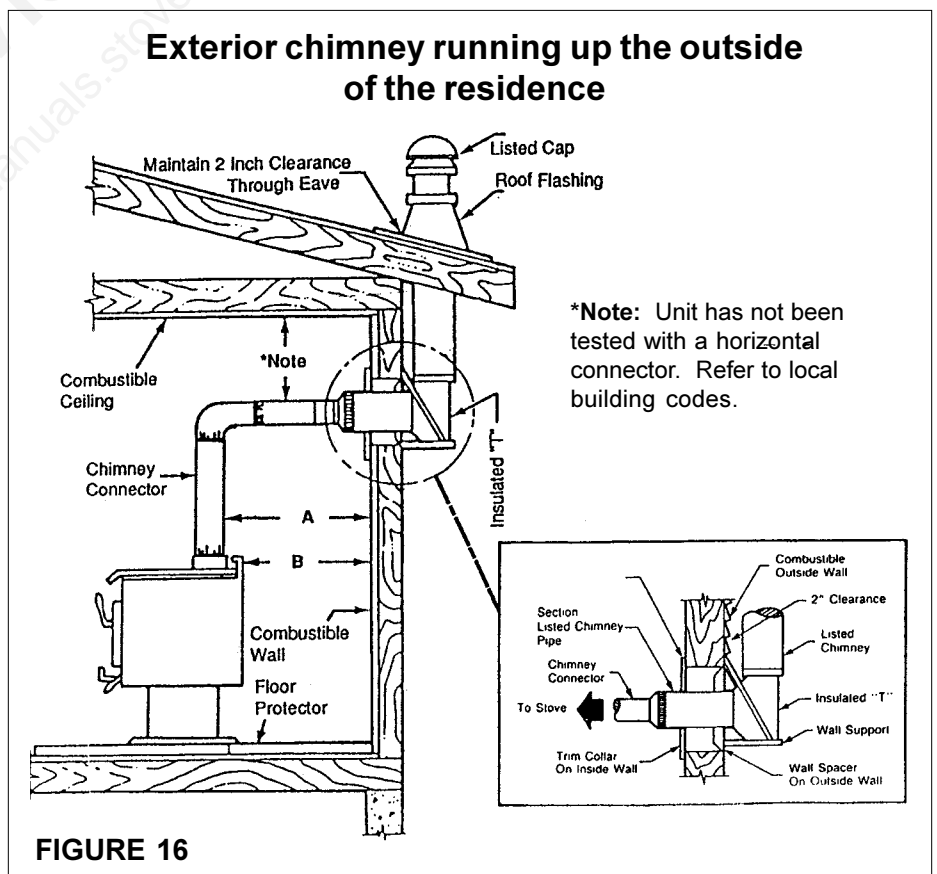
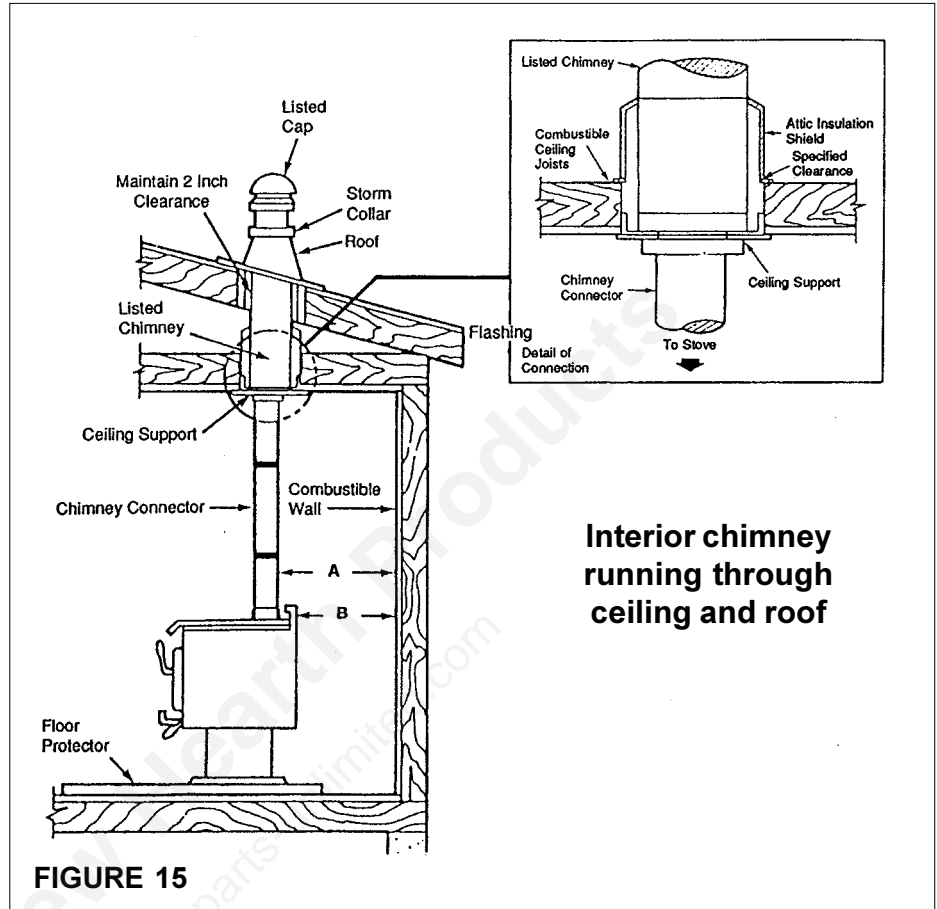

DOOR INSTALLATION

WARNING: Do not operate your stove before fully assembling all components. Burning your stove without a door will void your warranty, and could present a safety hazard.

1. Firmly hold door so that the hinges on the door line up with the hinges on the stove. The door hinges should be above the stove hinges and the handle should point away from the stove (see Figure 17).
2. Slide the hinge pins into hinges making sure the hinge pins go all the way through both the door and stove hinges.

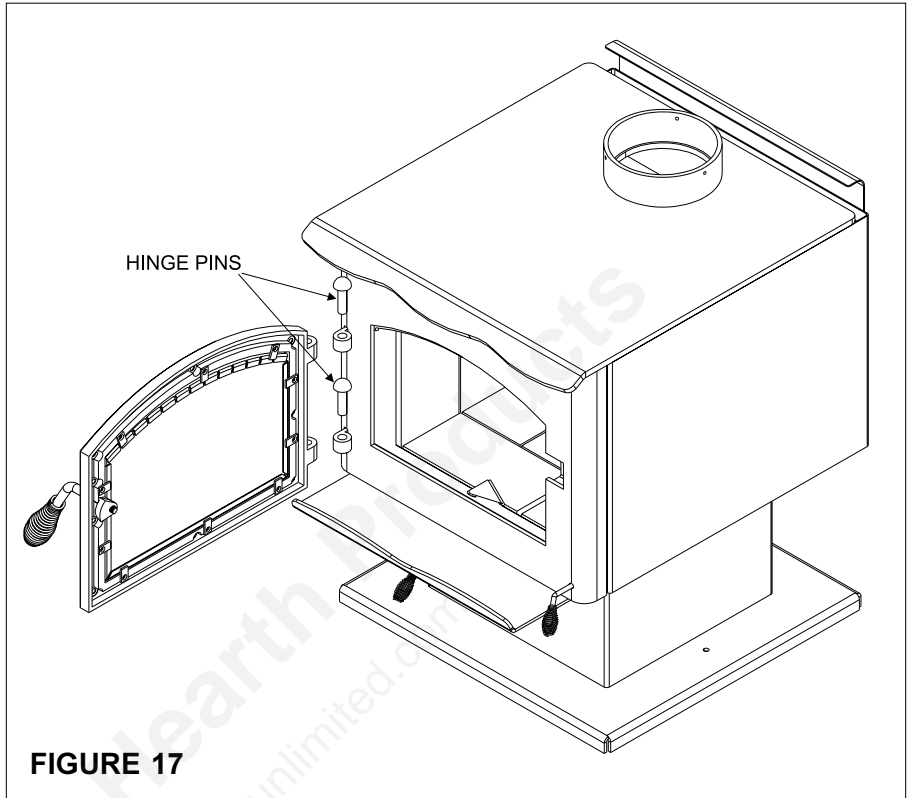

FIGURE 17

MOBILE HOME INSTALLATION

AN OUTSIDE AIR KIT IS REQUIRED FOR MOBILE HOME INSTALLATION.

You must use an outside air kit (see Outside Air Kit Installation) for installing in a mobile home. Use of alternative material will void warranty.

1. An outside air inlet must be provided for combustion and be unrestricted while unit is in use.
2. Unit must be secured to the mobile home structure by bolting pedestal through hearth pad and into floor.
3. Do not install unit in a sleeping room.
4. The structural integrity of the mobile home floor, walls, and ceiling/roof must be maintained (i.e., do not cut through floor joist, wall stud, ceiling truss, etc.).
5. Unit must be grounded with #8 copper grounding wire or equivalent and terminated at each end

6. with N.E.C. approved grounding device.
6. Refer to clearance to combustibles section (Figure 5) for listing to combustibles.
7. Seal all wall/floor inlets to prevent air or moisture penetration. Check periodically to insure the inlet is free of obstructions (e.g., snow or ice).
8. Burn wood only. Other types of fuels may generate poisonous gases (e.g., carbon monoxide).
9. If unit burns poorly while exhaust blower is on in home, increase combustion air.

NOTE: Offsets from the vertical, not exceeding 45°, are allowed per Section 905(a) of the Uniform Mechanical Code (UMC). Offsets greater than 45° are considered horizontal and are also allowed, providing the horizontal run does not exceed 75% of the vertical height of the vent. Construction, clearance and termination must be in compliance with the UMC Table 9C. This installation also complies with NFPA 211.

LEG KIT INSTALLATION

WARNING: Do not operate your stove before fully assembling all components. Burning your stove without a pedestal or leg kit attached will void your warranty, and could present a safety hazard.

1. Place protective pad or stove pallet on floor (see Figure 18).
2. Lay body of stove on its back on protective pad or pallet.
3. Slip washer onto bolts, then bolt legs onto adapter plate.
4. Carefully stand stove up and place in desired location.
5. Open door of stove and check to insure firebricks and koawool blanket are in their proper location.

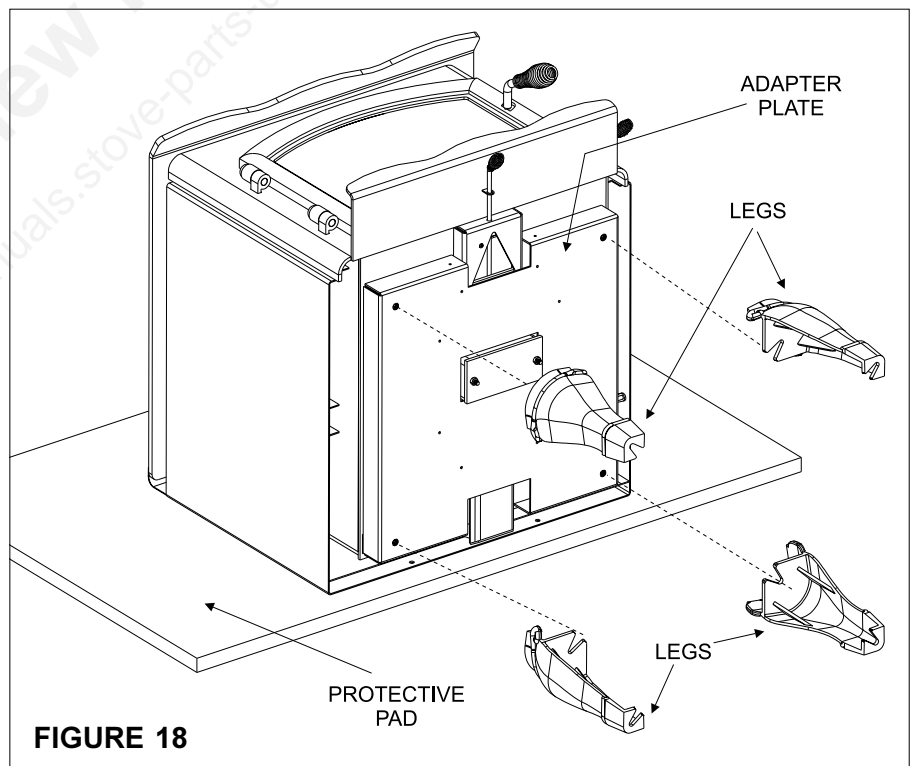

FIGURE 18

OUTSIDE AIR KIT INSTALLATION

FOR PEDESTAL MODELS

- (1) Front Cover
- (1) Rear Intake Cover
- (1) Rodent Screen
- (6) 8-32 x 1/2" screws

TOOLS AND PARTS NEEDED:

#2 Phillips Screw Driver, sufficient quantity of metalflex or rigid pipe for your connection purposes, silicone sealant.

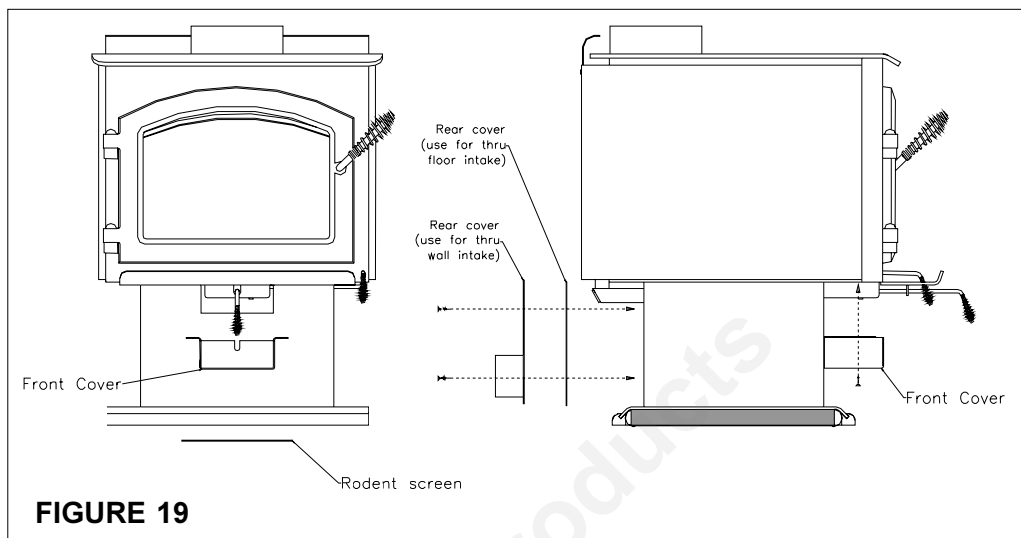

FIGURE 19

FLOOR INSTALLATION: (See Figure 19)

1. Cut a hole in the floor to accommodate outside air piping.
2. Run piping and install rodent screen to the outside end of piping.
3. Install rear cover and front cover with #8-32 screws.
4. Seal between the floor and pipe with silicone to prevent moisture penetration.
5. Slide stove into position.

WALL INSTALLATION: (See Figure 19)

1. Cut a hole in the outside wall to accommodate outside air piping.
2. Run piping and install rodent screen.
3. Install rear cover and front cover with #8-32 screws and attach piping.
4. Slide stove into position and adjust piping.
5. Seal between the wall and pipe with silicone to prevent moisture penetration.

FOR LEG MODELS

- (1) Front Cover
- (1) Rear Intake Cover
- (1) Rodent Screen
- (4) 8-32 x 1/2" screws

TOOLS AND PARTS NEEDED:

#2 Phillips Screw Driver, sufficient quantity of metalflex or rigid pipe for your connection purposes, silicone sealant.

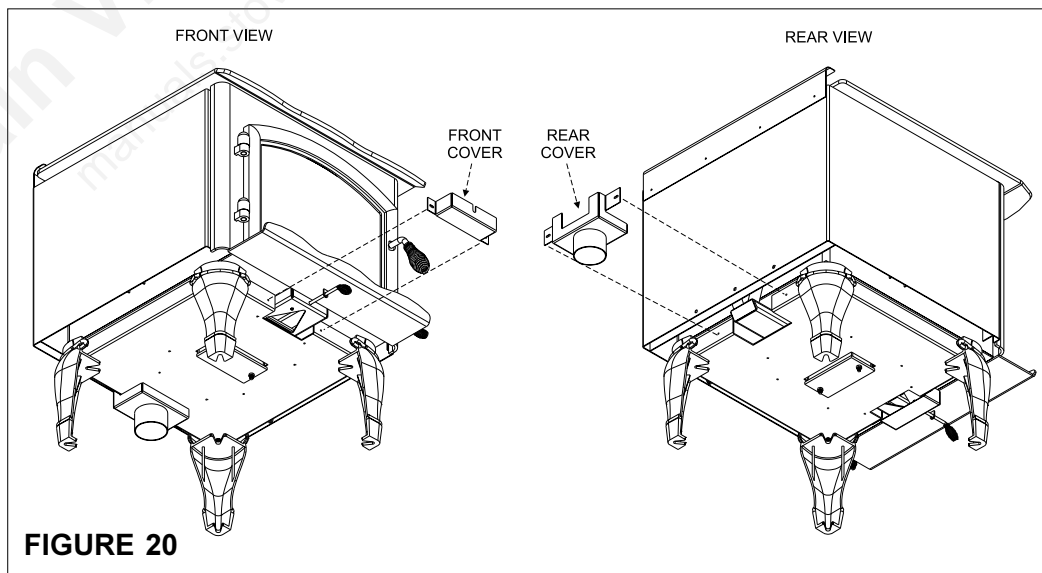

FIGURE 20

FLOOR OR WALL INSTALLATION:

(See Figure 20)

1. Cut a hole in the floor or wall to accommodate outside air piping.
2. Run piping and install rodent screen to the outside end of piping.
3. Install rear cover and front cover with #8-32 x 1/2" screws and attach piping.
4. Slide stove into position and adjust piping.
5. Seal between the floor and pipe, or wall and pipe with silicone to prevent moisture penetration.

INSTALLATION OF OPTIONAL BLOWER

Part #831-1700

The blower is shipped fully assembled and ready for installation.

1. Using three 1/4-20 bolts supplied, attach blower to lower rear of stove, as shown.
2. Plug blower cord into a grounded outlet. Do not remove ground prong from plug. Route power cord to avoid heat from the stove, or other damage.
3. Adjust the blower speed control to the desired speed.

BLOWER SWITCH ADJUSTMENTS

The blower speed control for this unit is adjusted at the factory, and should not require further adjustment. When the speed control is turned clockwise, it will click on to high speed. Turn the speed control clockwise to decrease the speed. At full clockwise, the blower should blow gently, but should not stop.

STEPS FOR ADJUSTING THE BLOWER SPEED CONTROL

1. With the unit plugged in, turn the speed control knob to slow (full clockwise).
2. With a small screwdriver, adjust the blower speed by turning the adjustment mechanism through the hole on the side of the speed control.
3. Adjust the speed so the blower runs slowly, but does not stop. Turn clockwise to slow the blower and counterclockwise to increase the speed.

BLOWER OPERATING INSTRUCTIONS

If your wood stove is equipped with an optional blower, you should follow these guidelines:

1. Initial (cold) start-up: Leave blower off until your stove is hot and a good coalbed is established. The blower may be turned on approximately 30 minutes after loading the stove with fuel.
2. High burn setting: The blower may be left on throughout the burn.

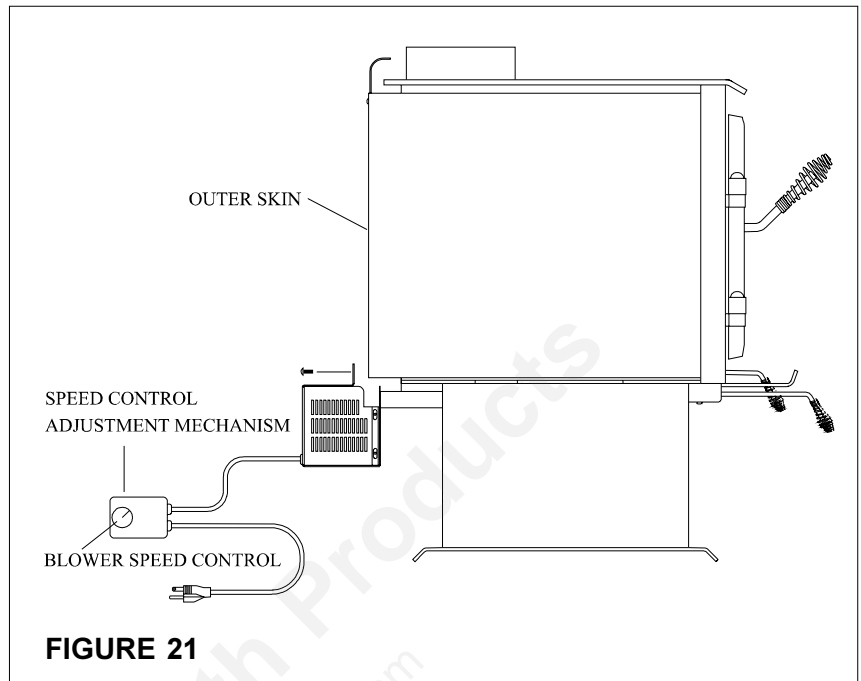

3. Medium burn setting: The blower should be left off until a good burn is established, then turned on at a medium or high rate.
4. Low burn setting: The blower tends to cool off the stove. If you are using wet wood or a very low burn setting, leave blower off until the burn is well established. Then, if you wish, turn the blower on at a lower rate. Too high a blower setting with a low burn rate may adversely affect emissions.
5. The blower is equipped with a speed control. The highest blower speed is obtained by turning the speed control on and then adjusting back towards off as far as possible without turning the blower off. For a low blower speed, turn the control knob clockwise as far as possible.

ASH REMOVAL SYSTEM INSTALLATION

1. Remove ash removal system top and bottom cover plates by loosening nuts under stove.
2. Discard both plates.
3. Place protective pad or stove pallet on floor.
4. Lay body of stove on its back on protective pad or pallet.
5. Line up holes in ash removal system with holes in adapter on bottom of stove (see Figure 22).
6. Screw ash removal system in place.
7. Carefully stand stove up and place in desired location.
8. Open door of stove and check to insure firebricks and kaowool blanket are in their proper locations.
9. Insert ash removal system grate into opening in firebox floor.

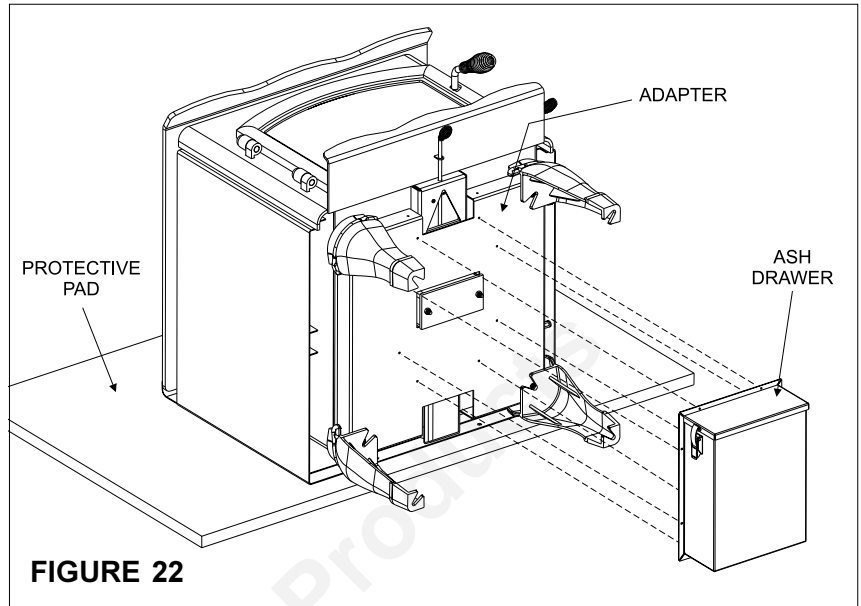

FIGURE 22

OPERATING AND CLEANING

CAUTION: DO NOT operate stove with ash removal system door open. Ensure that embers have cooled completely before removing ash.

1. When stove is cool, open front door and brush most of the ash into the center of the firebox. Remember to leave 1/4" to 1/2" (6-13mm) of ash on the firebox floor to act as a natural grate, allowing air to flow freely underneath wood .
2. Clean ash down through the ash removal system grate into the drawer below. If there are large pieces in the ashes, you can remove the grate before cleaning the ash into the drawer. Be sure to replace the grate before operating the stove.
3. Release latch on side of ash removal door (see Figure 23).
4. Pull out the ash drawer. Close ash removal door. (Closing this door avoids ash blowing into the room in the event of a downdraft.)
5. Empty ashes into metal container. Store container on non-combustible surface until ashes are cool enough to dispose.

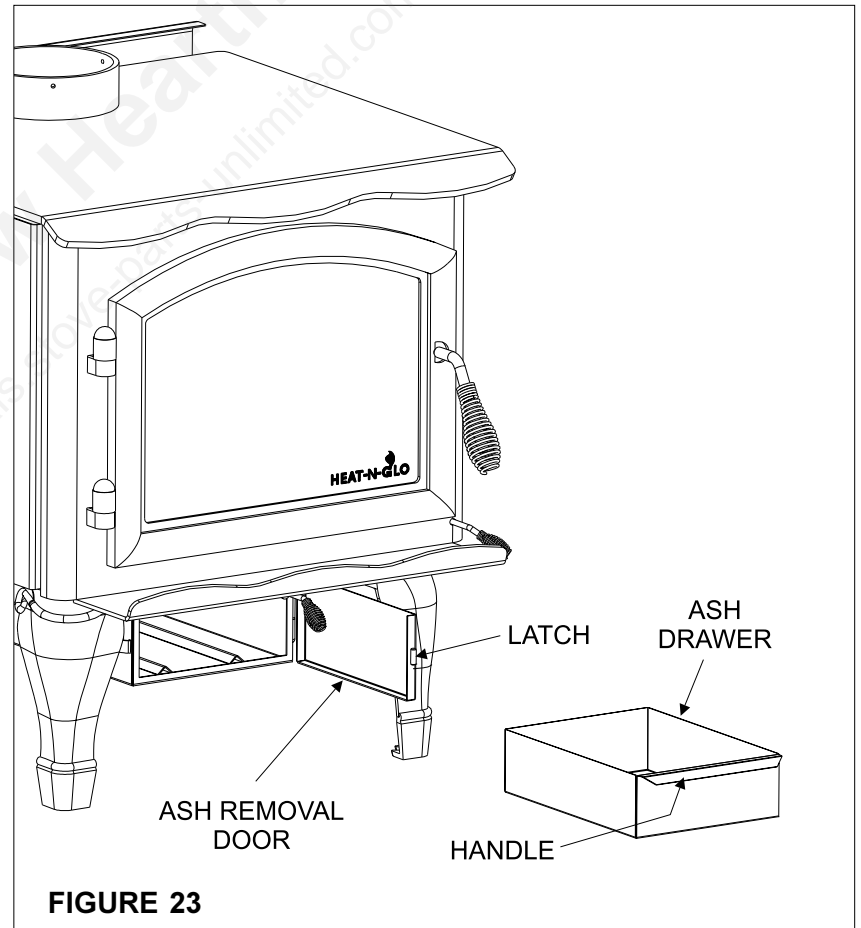

FIGURE 23

6. Open ash removal door and replace ash drawer, making sure handle faces forward.
7. Close ash removal door and fasten latch.

OPERATING INSTRUCTIONS

IMPORTANT - PLEASE READ BEFORE USING STOVE

BURNING PROCESS

In recent years there has been an increasing concern about the quality of our air. Much of the blame for poor air quality has been placed on the burning of wood for home heating. In order to improve the situation, we at Heat-N-Glo have developed cleaner burning wood stoves that surpass the stringent requirements for emissions established by our governing agencies.

Properly operated and maintained your WS-150 or WS-250 wood stove will obtain the peak efficiency and lowest emissions possible, resulting in better air quality for your community and more heat output per pound of wood. Improper operation and maintenance may cause any wood burning unit to release more particulate and adversely affect the environment.

It helps to know a little about the actual process of burning in order to understand how to operate the stove for best performance. The first stage of burning we will call the *kindling stage*. In this stage, the wood is heated to a temperature high enough to evaporate the moisture which is present in all wood. The wood will reach the boiling point of water (212°F) and will not get any hotter until the water is evaporated. This process takes heat from the coals and tends to cool the stove. Fire requires three things to burn: fuel, air and heat. So, if heat is robbed from the stove during the drying stage, the new load of wood has reduced the chances for a good clean burn. For this reason, it is always best to burn dry, seasoned firewood. When the wood isn't dry, you must open

the air controls and burn the stove at a high burn setting for a longer time to start it burning. The control on the right side of the stove is called the primary control; it is used mainly during the kindling stage of burning, or when burning the stove at a high burn setting. It should be closed (pulled outward) for lower burns.

The next stage of burning, the *secondary stage*, is the period when the wood gives off flammable gases which burn above the fuel with bright flames. During this stage of burning it is very important that the flames be maintained and not allowed to go out. This will insure the cleanest possible fire. If you are adjusting your stove for a low burn rate, you should close down the air to the point where you can still maintain some flame. If the flames tend to go out, the stove is set too low for your burning conditions. The air control in the center of the stove, beneath the ash catcher, is the one used to adjust the stove for lower burn rates. This is called the secondary control. Pulling either control towards you closes it, pushing it in opens it.

The final stage of burning is the *charcoal stage*. This occurs when the flammable gases have been mostly burned and only charcoal remains. This is a naturally clean portion of the burn. The coals burn with hot blue flames. It is very important to reload your stove while enough lively hot coals remain in order to provide the amount of heat needed to dry and rekindle the next load of wood. It is best to open the air controls for a short while before reloading. This livens up the coal bed. Open door slowly so that ash or smoke does not exit stove through opening. You should also break up any large chunks and distribute the coals so that the new wood is laid on hot coals.

Following these standards for operation and maintenance is a responsible action for the choice to heat your home with wood. In addition, you will also extend the life of your wood stove for many years of use and enjoyment.

PRIMARY AIR SYSTEM

The primary combustion air enters at the rear of the firebox through the primary air tubes. For **more** heat push control **in**, for **less** heat pull control **out**.

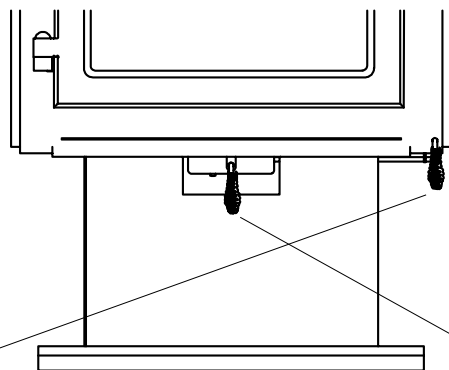

SECONDARY AIR SYSTEM

The secondary air enters at the upper front of the firebox, near the top of the glass door. This preheated air supplies the necessary fresh oxygen to mix with the unburned gases, helping to create secondary, tertiary and quaternary combustions. This air is regulated by the secondary control. For **more** secondary air push control **in**, for **less** secondary air pull control **out**.

Primary Control

Secondary Control

FIGURE 24

WOOD SELECTION AND STORAGE

Burn only dry seasoned wood! Dry and well-seasoned wood will not only minimize the chance of creosote formation, but will give you the most efficient heat output. Even dry wood contains at least 15% moisture by weight and should be burned hot enough to keep the chimney hot for as long as it takes to maintain particulate (smoke) burning. It is a waste of energy to burn unseasoned wood of any variety.

Dead wood lying on the forest floor should be considered wet, and requires full seasoning time. Standing dead wood can be considered to be about two-thirds seasoned. To tell if wood is dry enough to burn, check the ends of the logs. If there are cracks radiating in all directions from the center, it is dry. If your wood sizzles in the fire, even though the surface is dry, it may not be fully cured. Splitting wood before it is stored reduces drying time. Wood should be stacked so that both ends of each piece are exposed to air, since more

drying occurs through the cut ends than the sides. This is true even with wood that has been split. Store wood under cover, such as in a shed, or covered with a tarp, plastic, tar paper, sheets of scrap plywood, etc., as uncovered wood can absorb water from rain or snow, delaying the seasoning process.

OVERFIRING

Do not overfire. Using flammable liquids or too much wood, or burning trash in the stove may result in overfiring. If the chimney connector or stove glows red, or worse white, the stove is overfired. This condition may ignite creosote in the chimney, possibly causing a house fire. If any part of the insert starts to glow, you are in an overfire situation. If you overfire, immediately close the stove dampers and door, if open, to reduce the air supply to the fire. **OVERFIRING YOUR STOVE VOIDS THE WARRANTY.**

BUILDING A FIRE

NOTE: Remove all labels from glass front prior to lighting the first fire.

Before lighting your first fire in the stove, make certain that the baffle is correctly positioned. It should be resting on the rear baffle support so that the hole in the baffle lines up with the baffle locating pin (see baffle installation instructions). You will be able to visually check this alignment.

There are many ways to build a fire. The basic principle is to light easily-ignitable tinder or paper, which ignites the fast burning kindling, which in turn ignites the slow-burning firewood. Here is one method that works well:

1. Place several wads of crushed paper on the fire-box floor.
2. Lay small dry sticks of kindling on top of the paper.
3. Open primary and secondary controls fully.
4. Make sure that no matches or other combustibles are in the immediate area of the stove. Be sure the room is adequately ventilated and the flue unobstructed.
5. Light the paper in the stove. **NEVER** light or rekindle stove with kerosene, gasoline, or charcoal lighter fluid; the results can be fatal.

6. Once the kindling is burning quickly, add several full-length logs 3" (76mm) or 4" (102mm) in diameter. Be careful not to smother the fire. Stack the pieces of wood carefully: near enough to keep each other hot, but far enough away from each other to allow adequate air flow between them.
7. When ready to reload the stove, add more logs. Large logs burn slowly, holding a fire longer. Small logs burn fast and hot, giving quick heat.
8. Adjust the primary and secondary air controls; the more you close down the controls, the lower and slower the fire will burn. The more open the controls, the more heat will be produced.

As long as there are hot coals, repeating steps 7 and 8 will maintain a continuous fire throughout the season.

NOTE: The special high temperature paint that your stove is finished with will cure as your stove heats. You will notice an odor and perhaps see some vapor rise from the stove surface; this is normal. We recommend that you open a window until the odor dissipates and paint is cured.

NOTE: On a cold start-up, you may see a small amount of smoke coming from the underside of stove until chimney draft is established. This is normal, and will stop when the loading door is closed.

BURNING GUIDELINES

OPACITY: This is the measure of how cleanly your stove is burning. Opacity is measured in percent; 100% opacity is when an object is totally obscured by the smoke column from a chimney, and 0% opacity means that no smoke column can be seen. As you become familiar with your stove, you should periodically check the opacity of the smoke column emitted from your chimney. This will allow you to know how to burn your stove as nearly smoke-free as possible (aim for a goal of 0% opacity).

BURN RATES

HIGH: Open (push in) both controls fully. It is important to do this when reloading the stove. Failure to do this could result in excessive emissions (opacity).

MEDIUM: After a wood load has been burning on high for at least 15 minutes (longer for very large pieces or wet wood), close (pull out) the primary control (on the right side of the stove). Leave the secondary control (under the ash catcher) open (pushed in).

LOW: After a wood load has been burning on high for at least 15 minutes (longer for very large pieces or wet wood), close (pull out) the primary control. Then close down the secondary control, gradually making sure to maintain flames in the stove. It is very important to maintain flames in your stove during the first few hours of a low burn, to avoid excessive air pollution.

OPERATING TIPS

Here are a few tips on operating your stove to obtain maximum efficiency with lowest emissions:

1. Regardless of desired heat output, when loading stove, burn your stove with both air controls wide open for a minimum of 15 minutes.
2. Regulate burn rate (heat output) by using the secondary control (center, under ash catcher). The primary control (on the right) is mainly for initial start-up, reloading, or high burns.
3. Heat output settings: Following 15 minutes of burning with controls wide open (see #1 above):

<u>BTU/Hr.</u>	<u>Primary</u>	<u>Secondary</u>
Below 10,000	Closed after 5 min.	Pull to stop
10,000-15,000	Closed after 5 min.	¾" - 1" open
15,000-30,000	Closed after 5 min.	1" - 2½" open
Maximum heat	Full open	Full open

These are approximate settings, and will vary with type of wood or chimney draft.

4. Burn dry, well-seasoned wood (see Wood Selection and Storage).

MAINTENANCE

CREOSOTE

Formation and need for removal:

When wood is burned slowly, it produces tar and other organic vapors which combine with expelled moisture to form creosote. The creosote vapors condense in the relatively cool chimney flue of a newly-started or a slow-burning fire. As a result, creosote residue accumulates on the flue lining. When ignited, this creosote creates an extremely hot fire which may damage the chimney or even destroy the house. The chimney connector and chimney should be inspected at least twice monthly during the heating season to determine if a creosote buildup has occurred. If creosote has accumulated, it should be removed to reduce the risk of a chimney fire.

Inspection:

Inspect the system at the stove connection and at the chimney top. Cooler surfaces tend to build creosote deposits quicker, so it is important to check the chimney from the top as well as from the bottom.

Removal:

The creosote should be removed with a brush specifically designed for the type of chimney in use. A chimney sweep can perform this service. It is also recommended that before each heating season the entire system be professionally inspected, and cleaned and repaired if necessary.

CARE AND CLEANING OF GLASS

NOTE: Remove all labels from glass before lighting the first fire in the stove.

The stove is equipped with ceramic super heat-resistant glass, which can only be broken by impact or misuse. Do not slam stove door or impact the glass.

When closing door, make sure that logs do not protrude against the glass. Clean glass with a non-abrasive glass cleaner, such as Windex. Abrasive cleaners may scratch and cause glass to crack. Inspect glass regularly. If you find a crack or break, immediately put the fire out and return the door to your dealer for replacement of glass before further use. **NOTE:** Replace with ceramic glass only.

CHIMNEY CLEANING

Disconnect flue pipe from stove before cleaning chimney. Otherwise residue can pile up on top of the baffle, and the stove will not work properly.

ASH REMOVAL

Remove cold ashes (NEVER HOT) from the stove by shoveling them into a metal container with a tight-fitting lid. Spraying cold ashes with water before shoveling them out of the stove will help eliminate ash flying around the firebox and into the room. Always treat ashes as if they contain hot coals, and store the container on a noncombustible floor away from combustible material pending final disposal.

FIREBRICK

The firebox of the stove is lined with high quality firebrick, which has exceptional insulating properties. There is no need for using a grate; simply build a fire on the firebox floor of the stove.

GLASS REPLACEMENT

1. Remove door from stove and lay on a padded flat surface.
2. Remove glass tabs (See figure 25) and screws with a Phillips screwdriver (turn screws counter-clockwise).
3. Lift glass frame pieces and glass out of the door frame.
4. Lay new glass with fiberglass tape around it into the door frame, making sure the Heat-N-Glo logo reads correctly to the outside.
5. Place glass frame pieces over the fiberglass tape on the edges of the glass. Be sure glass is centered in the opening (i.e., same space top and bottom, left and right sides).

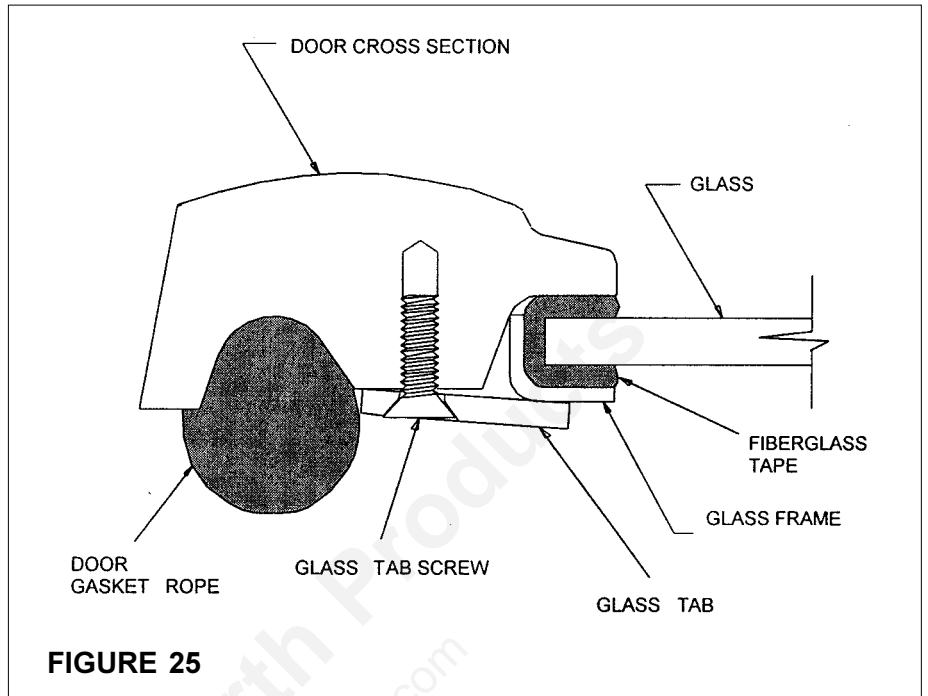

6. Reinstall screws and glass tabs tight enough to hold glass and frame in place. **DO NOT OVERTIGHTEN.**
7. Check again for centering of glass in door frame, and give all screws a final tightening.

DOOR HANDLE ASSEMBLY

NOTE: Spring handle not included in door handle assembly. When replacing door handle, either use old spring handle or order new spring handle separately (See Figure 26).

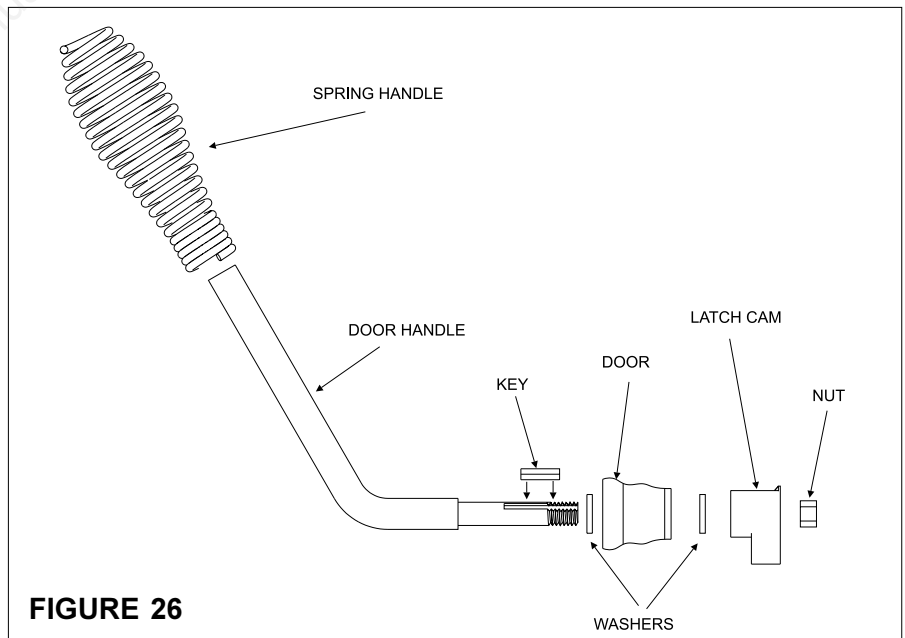

BAFFLE REMOVAL AND INSTALLATION

NOTE: The baffle in this stove is heavy. Moving the baffle around inside the stove takes strength and patience. Removing hardware exposed to combustion processes can be frustrating. If your reason for removing the baffle is simply to clean the chimney, you have alternatives which will save time and effort. Call a qualified chimney sweep or an authorized Heat-N-Glo dealer for details.

1. Remove all ash from the firebox, and extinguish all hot embers before disposal into a metal container.
2. Remove the kaowool blanket from above the baffle.
3. Remove the firebrick from the sides of the stove.
4. With a 3/16" allen wrench, remove the secondary combustion tube retainer bolts on the secondary air channel under the end of each tube. **NOTE:** Soak the bolts with penetrating oil for at least 15 minutes before trying to remove them.
5. To remove the secondary combustion tubes, slide the tube to one side until one end is out of its hole. Then, while lifting that end of the baffle plate, pull the tube up over the secondary air channel and out of the hole at the other end. **NOTE:** When replacing the secondary tubes, be sure the tube with the larger holes is placed in the front for the WS-250.
6. To remove the baffle plate, use both hands to lift it from the alignment pin at the center rear. Then tilt the baffle as you slide it to one side, until the other side clears the shelf.
7. Keep the baffle tilted as you lift it out the door.
8. To install the baffle, repeat steps 2 through 7 in reverse. Be sure that the hole in the baffle is on its alignment pin on the rear shelf.

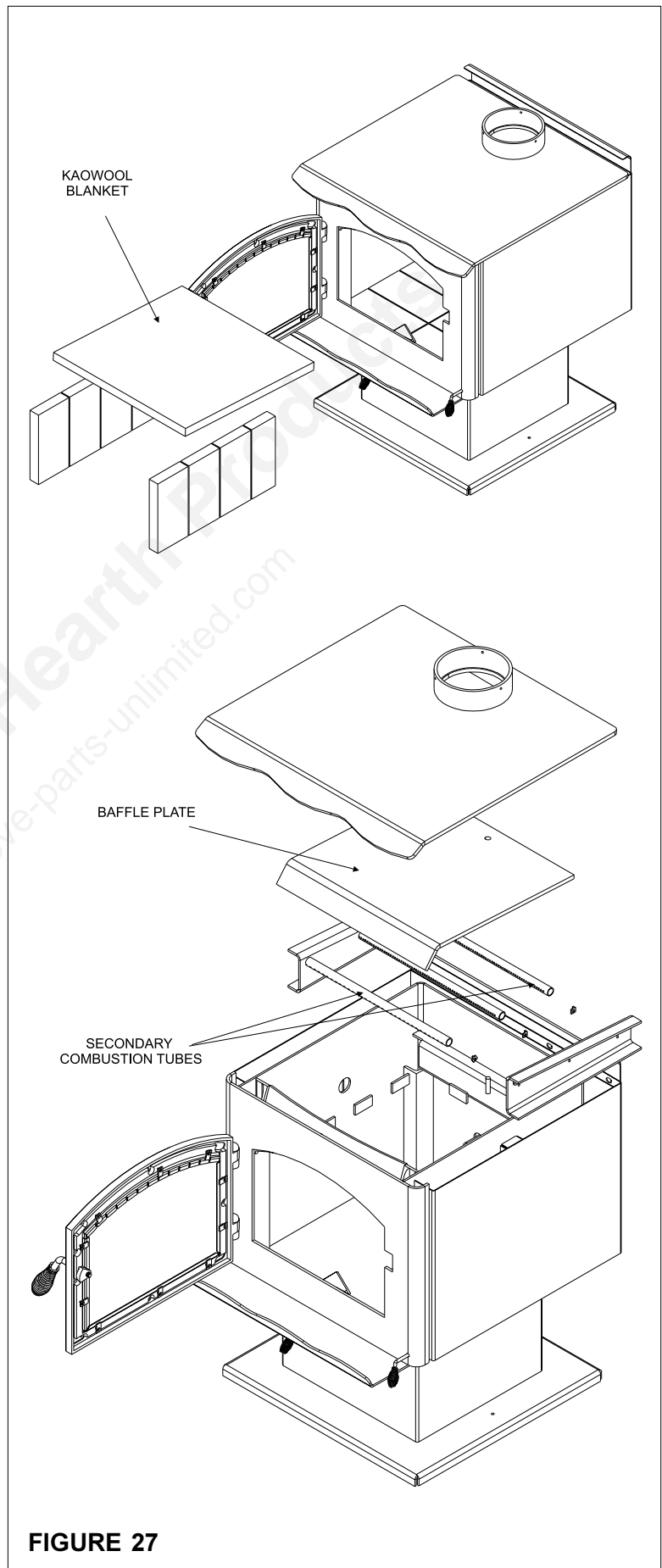

FIGURE 27

BRICK INSTALLATION

NOTE: See following page for service part numbers.

WS-150

BACK

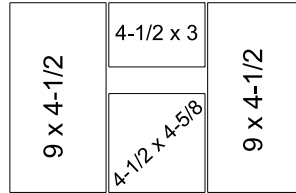

LEFT SIDE

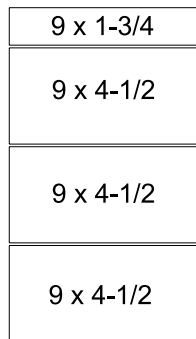

BOTTOM

(PEDESTAL VERSION)

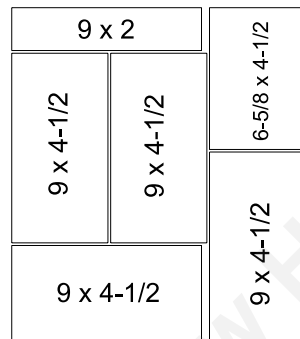

(LEG VERSION)

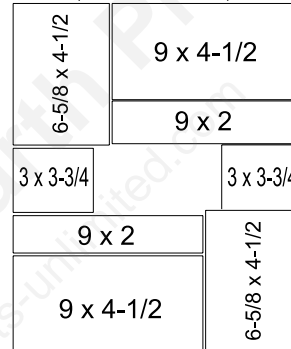

RIGHT SIDE

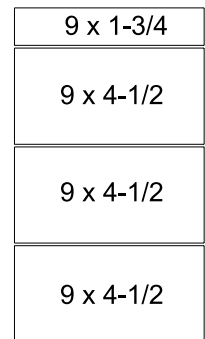

WS-250

BACK

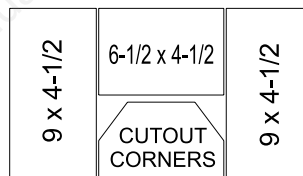

LEFT SIDE

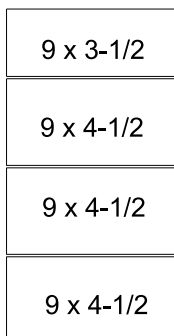

BOTTOM

(PEDESTAL VERSION)

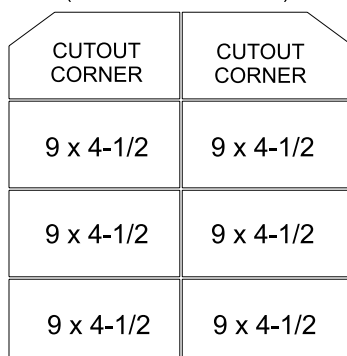

(LEG VERSION)

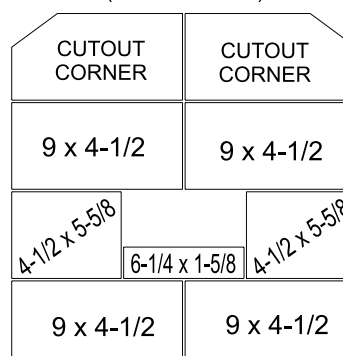

RIGHT SIDE

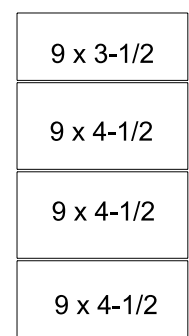

FIGURE 28

ACCESSORIES

Description	Part Number	Description	Part Number
Outside air kit, WS-150, rear	OSA-150R	WS-150 Black Door	WS150-BD
Outside air kit, WS-150, bottom	OSA-150B	WS-250 Black Door	WS250-BD
Outside air kit, WS-250, rear	OSA-250R	WS-150 Gold Door	WS150-GD
Outside air kit, leg models	OSA-WSL	WS-250 Gold Door	WS250-GD
Outside air kit, WS-250, bottom	OSA-250B	Gold Hinge Pins	WS-GHP
Blower	GFK160-WS	WS-150 Heat Diffuser	WS150-HE
Ash Removal System	WS-AD	Gold Grille for WS-150 Heat Diffuser	WS150-GG
Gold legs	WS-GL	WS-250 Heat Diffuser	WS250-HE
		Gold Grille for WS-250 Heat Diffuser	WS250-GG

SERVICE PARTS

Description	Part Number	Description	Part Number
Black Door, WS-150	SRV396-150	Firebrick, 4 1/2 x 5 5/8	SRV395-712
Black Door, WS-250	SRV395-150	Firebrick, 6 1/4 x 1 5/8	SRV395-713
Black Leg	SRV396-342	Firebrick, 6 5/8 x 4 1/2	SRV396-704
Door glass assembly, WS-150	GLA-WS150	Firebrick, 4 1/2 x 3	SRV396-705
Door glass assembly, WS-250	GLA-WS250	Firebrick, 4 1/2 x 4 5/8	SRV396-706
Door glass frame, WS-150	SRV396-144	Firebrick, 9 x 3 1/2	SRV395-707
Door glass frame, WS-250	SRV395-144	Firebrick, cutout corner	SRV395-708
Firebrick, 9 x 4 1/2	SRV396-701	Firebrick, 6 1/2 x 4 1/2	SRV395-709
Firebrick, 9 x 1 3/4	SRV396-702	Firebrick, cutout corners	SRV395-710
Firebrick, 9 x 2	SRV396-703	Spring handle, large	SRV396-301
Firebrick, 3 x 3 3/4	SRV396-711	Spring handle, small	SRV396-302

HEAT-N-GLO LIMITED LIFETIME WARRANTY

Heat-N-Glo, a division of Hearth Technologies Inc., warrants their wood heating appliances to the original purchaser for the lifetime of the appliance, to be free from defects in material and workmanship. This warranty gives you specific legal rights; you may have other rights which may vary from state to state.

This limited Lifetime Warranty covers items such as but not limited to combustion chambers, doors, gold plating, steel baffles, manifold tubes, ash removal systems, and glass damaged by thermal breakage.

All parts to be replaced must be returned to an authorized Heat-N-Glo dealer at purchaser's expense for inspection and approval by Heat-N-Glo prior to repair or replacement. No repair or replacement costs will be honored without approval of Heat-N-Glo.

This new WS-150 or WS-250 product must be installed by a competent, authorized service contractor. It must be installed and operated at all times in accordance with the Installation and Operating Instructions in this manual, as well as any applicable local and national codes. Any alteration, willful abuse, accident, or misuse of the product shall void this warranty.

Any installation, construction, transportation, or other related costs or expenses arising from defective part(s), repair, replacement, etc., will not be covered by this warranty, nor will Heat-N-Glo assume responsibility for them. Further, Heat-N-Glo will not be responsible for any incidental, indirect, or consequential damages, except as provided by law.

All electrical components such as but not limited to blowers, wiring, speed controls, and thermodisc switches are covered by Heat-N-Glo's one year warranty program.

Heat-N-Glo will not be responsible for any alteration to the unit which causes sooting that results in damage to the interior or exterior of the building in which this appliance is installed.

This warranty is void if the stove has been operated in atmospheres contaminated by chlorine, fluorine, or other damaging chemicals, the stove is subjected to prolonged periods of dampness or condensation, or there is any damage to the stove or other components due to water or weather damage which is the result of, but not limited to, improper chimney or venting installation.

This limited Lifetime Warranty does not extend to or include paint, door gasketing, glass gasketing, firebrick, kaowool or other ceramic insulating materials. It does not cover installation or operational-related problems such as overfiring, use of corrosive driftwood, downdrafts or spillage caused by environmental conditions, nearby trees, buildings, hilltops, mountains, inadequate venting or ventilation, excessive offsets, or negative air pressures caused by mechanical systems such as furnaces, fans, clothes dryers, etc.

This limited Lifetime Warranty does not apply to venting components, hearth components or other accessories used in conjunction with the installation of this product not manufactured by Heat-N-Glo.

This limited Lifetime Warranty is effective on all wood stoves sold after September 1, 1996, and supersedes any and all warranties currently in existence.

- IMPORTANT -

This warranty is not valid unless the warranty registration card has been properly completed in full and returned within 10 days from the date of purchase.