



Heatilator Inc.  
1915 W. Saunders Street  
Mt. Pleasant, IA 52641  
Division, HON INDUSTRIES

**This appliance has been retired.  
Service parts pages within have been removed.  
For replacement parts, please refer to the individual  
service parts list located on the brand websites.**

# CC36 CC36I CD36 INSTALLATION & OPERATING INSTRUCTIONS FOR RESIDENTIAL USE

## I. LISTINGS AND CODE APPROVALS

These fireplace systems have been tested in accordance with Underwriters Laboratories Inc. Standards, and have been LISTED by them for installation and operation as described in these Installation & Operating Instructions.

Fireplace Catalog Numbers CC36, CC36I and CD36 have been tested and LISTED for use with the Optional Components described in Section II of these Instructions. These Optional Components may be purchased separately and installed at a later date. However, installation of the Outside Air Kit and Junction Box Kit (CC36 and CC36I only) will require significant reconstruction, and should be installed at the time of initial installation.

Check with your local building code agency before you begin installation to ensure compliance with local codes, including the need for "permits" and follow-up inspections. If any problems are encountered regarding code approvals, or if you wish clarification of any of the instructions contained here, contact: Customer Relations Department, Heatilator Inc., 1915 W. Saunders Street, Mt. Pleasant, Iowa 52641. HEATILATOR® is a registered trademark of Heatilator Inc., Division, HON INDUSTRIES.

### WARNING

**THIS HEATILATOR FIREPLACE AND ITS COMPONENTS ARE DESIGNED TO BE INSTALLED AND OPERATED AS A SYSTEM. ANY ALTERATION TO OR SUBSTITUTION FOR ITEMS IN THIS SYSTEM UNLESS ALLOWED BY THESE INSTALLATION INSTRUCTIONS WILL VOID THE UNDERWRITERS LABORATORIES LISTING AND MAY VOID THE PRODUCT WARRANTY. IT MAY ALSO CREATE A HAZARDOUS INSTALLATION. READ THROUGH THESE INSTRUCTIONS THOROUGHLY BEFORE STARTING YOUR INSTALLATION AND FOLLOW THEM CAREFULLY THROUGHOUT YOUR PROJECT.**

## II. DESCRIPTION OF THE FIREPLACE SYSTEM

The HEATILATOR® fireplace system consists of the following:

1. Fireplace
2. Hearth Extension
3. Chimney System
4. Roof Termination
5. Integral Grate

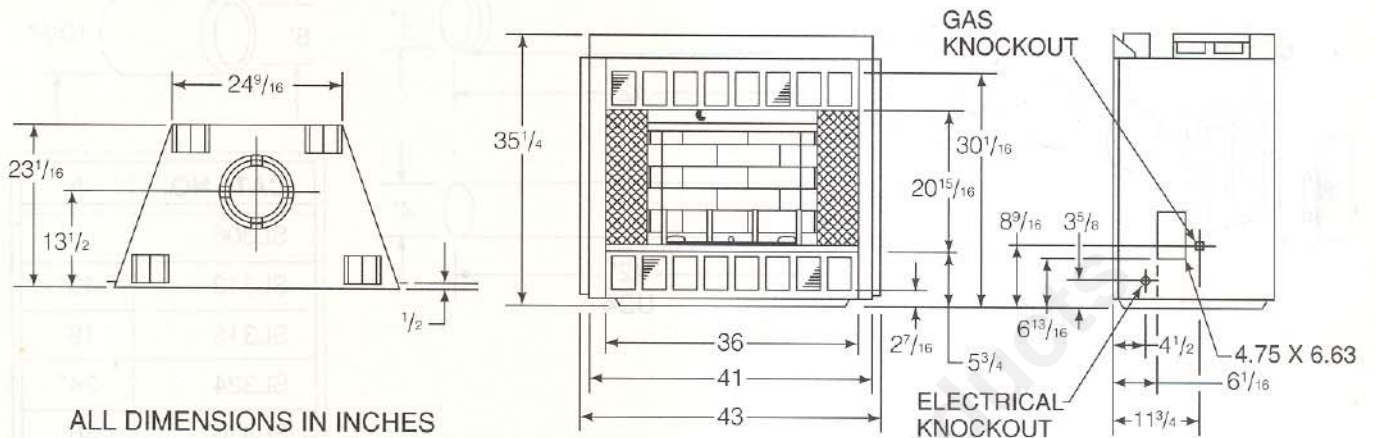
Optional components include:

1. Glass Doors
2. Outside Combustion Air System
3. Fan Kit (CC36 and CC36I only)

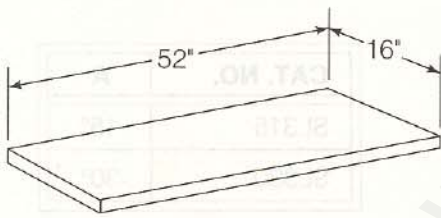
## THE FIREPLACE SYSTEM COMPONENTS

Catalog Number	Description
CC36	Fireplace
CC36I	Fireplace (Insulated Outer Shell)
CD36	Fireplace
HX3	Hearth Extension
GD36A	Glass Doors - Clear-View, Antique Solid Brass
GD36B	Glass Doors - Clear-View, Bright Solid Brass
GA36A	Glass Doors - Cabinet, Antique Solid Brass
GA36B	Glass Doors - Cabinet, Bright Solid Brass
C1136A	Classic Bifold Glass Doors - Brushed Brass Finish
C1136B	Classic Bifold Glass Doors - Polished Brass Finish
C1136C	Classic Bifold Glass Doors - Chrome Finish
C2136A	Classic Cabinet Glass Doors - Brushed Brass Finish
C2136B	Classic Cabinet Glass Doors - Polished Brass Finish
C2136C	Classic Cabinet Glass Doors - Chrome Finish
D1136B	Designer Series Bifold Glass Doors - Polished Brass Finish
D2136B	Designer Series Cabinet Glass Doors - Polished Brass Finish
GR36A00	Integral Grate (included with Fireplace)
FK1	Fan Kit (Raceway and Single Fan)
FK2	Fan Kit (Single Fan)
JK1	Junction Box Kit
AK14	Air Kit - Outside Air
ID4	Insulated Duct/Outside Air
UD4	Uninsulated Duct/Outside Air
SL306	Chimney Section - 6 inch long
SL312	Chimney Section - 12 inch long
SL318	Chimney Section - 18 inch long
SL324	Chimney Section - 24 inch long
SL336	Chimney Section - 36 inch long
SL348	Chimney Section - 48 inch long
SL3	Chimney Stabilizer
SL315	Chimney Offset/Return - 15°
SL330	Chimney Offset/Return - 30°
FS338	Firestop - Straight
FS339	Firestop - 15°
FS340	Firestop - 30°
JB877	Chimney Joint Band
CB876	Chimney Bracket
RF370	Roof Flashing - Flat to 6/12 Pitch
RF371	Roof Flashing - 6/12 to 12/12 Pitch
RT362	Telescoping Chimney Terminal Cap - Round
RT364	Chimney Terminal Cap - Round
RT364S	Chimney Terminal Cap, Stainless Steel - Round
RT382	Telescoping Chimney Terminal Cap - Round
RT384	Chimney Terminal Cap - Round
ST375	Chimney Terminal Cap - Square
ST376	Telescoping Chimney Terminal Cap - Square
ST8	Housing Top Chimney Terminal Cap
RB4	4' Simulated Red Brick Chimney Panels
TB4	4' Simulated Tan Brick Chimney Panels
RB6	6' Simulated Red Brick Chimney Panels
TB6	6' Simulated Tan Brick Chimney Panels
CT35	Chase Top

CC36, CC36I & CD36 FIREPLACES

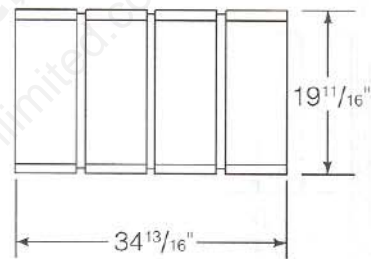


HEARTH EXTENSION



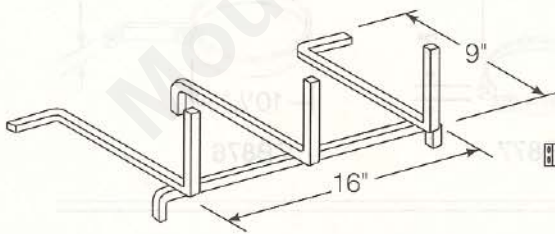
HX3

GLASS DOORS



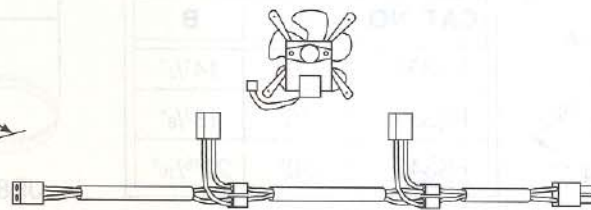
GD36A  
GD36B

INTEGRAL GRATE



GR36A00

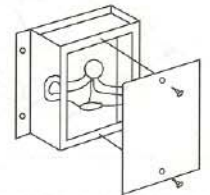
FAN KITS



FK1

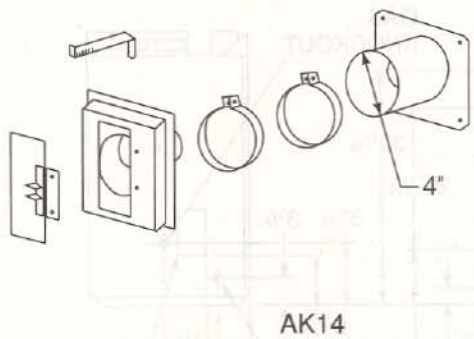
FK2

JUNCTION BOX KIT

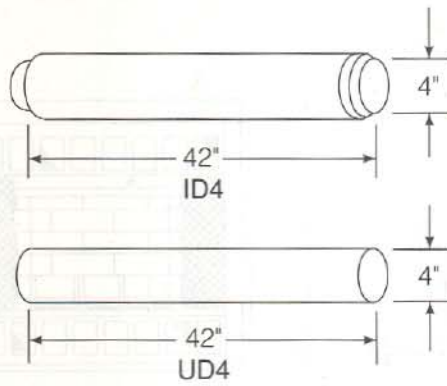


JK1

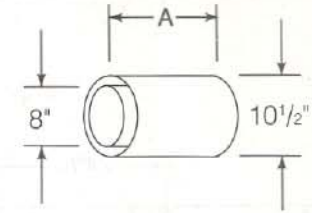
**AIR KIT**



AK14

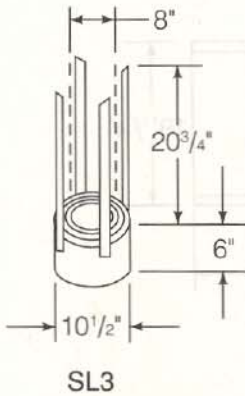


**CHIMNEY SECTIONS**



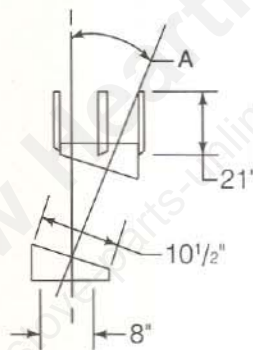
CAT. NO.	A
SL306	6"
SL312	12"
SL318	18"
SL324	24"
SL336	36"
SL348	48"

**CHIMNEY STABILIZER**



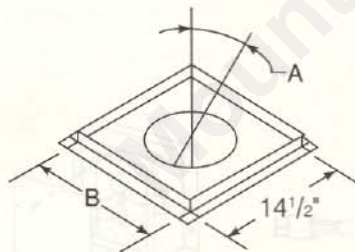
SL3

**OFFSETS/RETURNS**



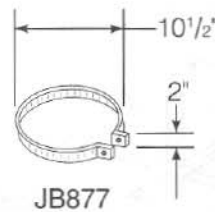
CAT. NO.	A
SL315	15°
SL330	30°

**FIRESTOP SPACERS**



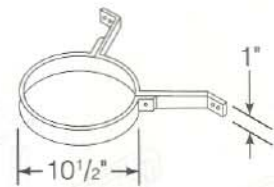
CAT. NO.	A	B
FS338	0°	14 1/2"
FS339	15°	18 3/8"
FS340	30°	22 15/16"

**JOINT BAND**



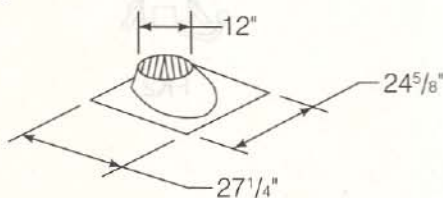
JB877

**CHIMNEY BRACKET**

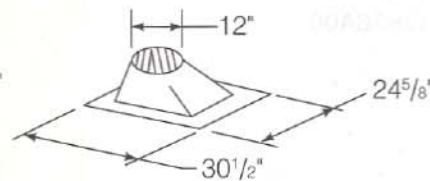


CB876

**ROOF FLASHINGS**

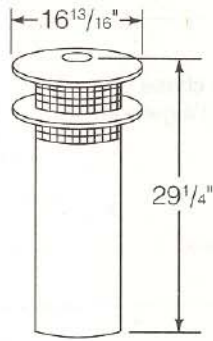


Flat to 6/12 Pitch  
RF370

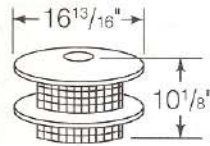


6/12 to 12/12 Pitch  
RF371

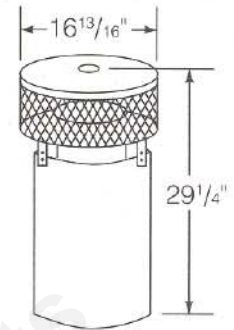
# CHIMNEY TERMINAL CAPS & TERMINATIONS



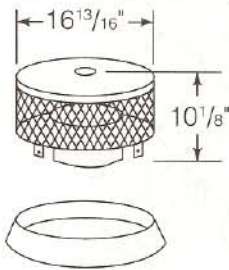
**RT362**  
ROUND TERMINAL CAP



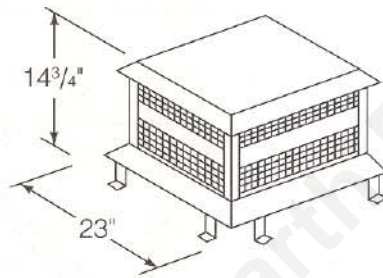
**RT364 & RT364S**  
ROUND TERMINAL CAP  
&  
STAINLESS STEEL ROUND  
TERMINAL CAP



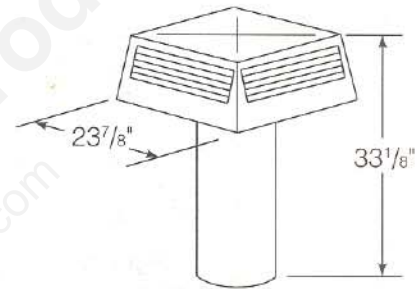
**RT382**  
ROUND TERMINAL CAP



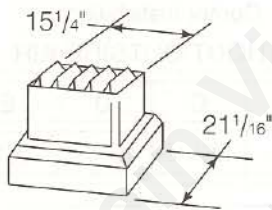
**RT384**  
ROUND TERMINAL CAP



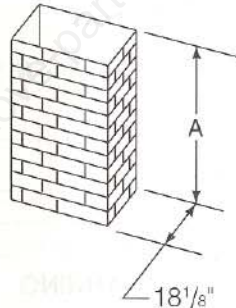
**ST375**  
SQUARE TERMINAL CAP



**ST376**  
SQUARE TERMINAL CAP



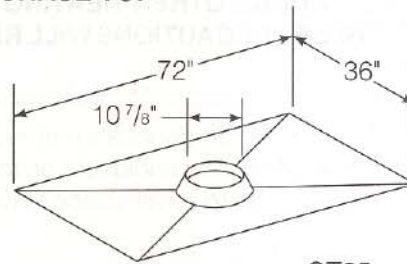
**ST8**  
HOUSING TOP



**SIMULATED BRICK TERMINATIONS**

CAT. NO.	A
RB4	45 3/4"
TB4	45 3/4"
RB6	69 3/4"
TB6	69 3/4"

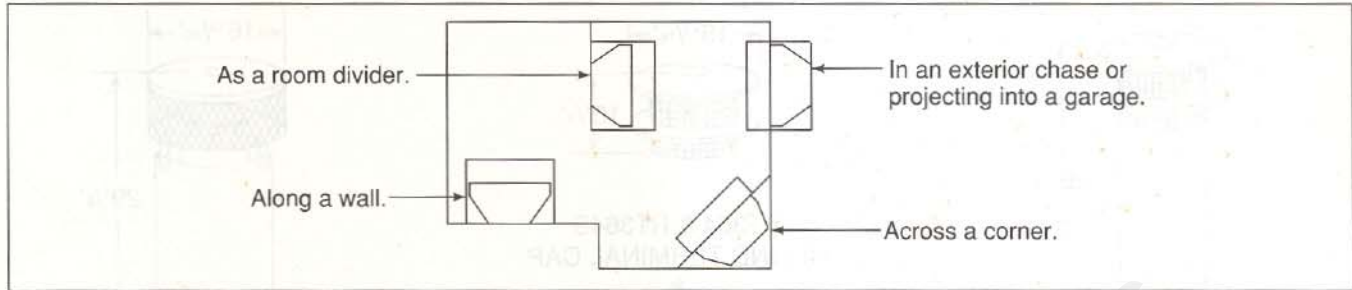
## CHASE TOP



**CT35**

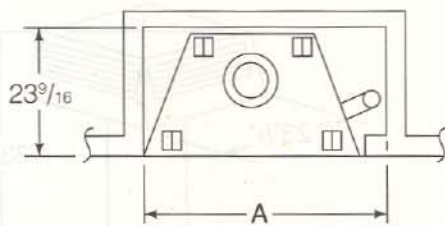
### III. FIREPLACE LOCATIONS, SPACE AND CONSTRUCTION REQUIREMENTS

The fireplace may be located as shown in Figure 1.



**Figure 1**  
Fireplace Locations

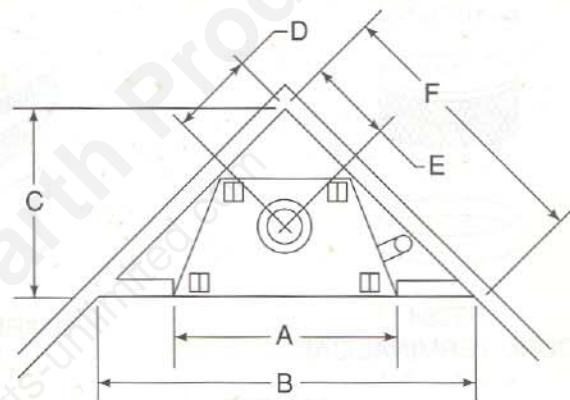
Figures 2 and 3 show installations assuming outside air ducts with allowance for making 90° bends. Less space is required when ducting goes directly outside without forming elbows.



**Figure 2**  
Installation along a wall  
or an exterior chase.

	A
WITHOUT OUTSIDE AIR	41 <sup>1</sup> / <sub>8</sub>
WITH OUTSIDE AIR	45 <sup>3</sup> / <sub>16</sub>

**ALL DIMENSIONS IN INCHES**



**Figure 3**

Corner Installation

WITH OR WITHOUT OUTSIDE AIR

A	B	C	D	E	F
41 <sup>1</sup> / <sub>8</sub>	72 <sup>1</sup> / <sub>8</sub>	36 <sup>1</sup> / <sub>16</sub>	15 <sup>15</sup> / <sub>16</sub>	15 <sup>15</sup> / <sub>16</sub>	51

#### WARNING

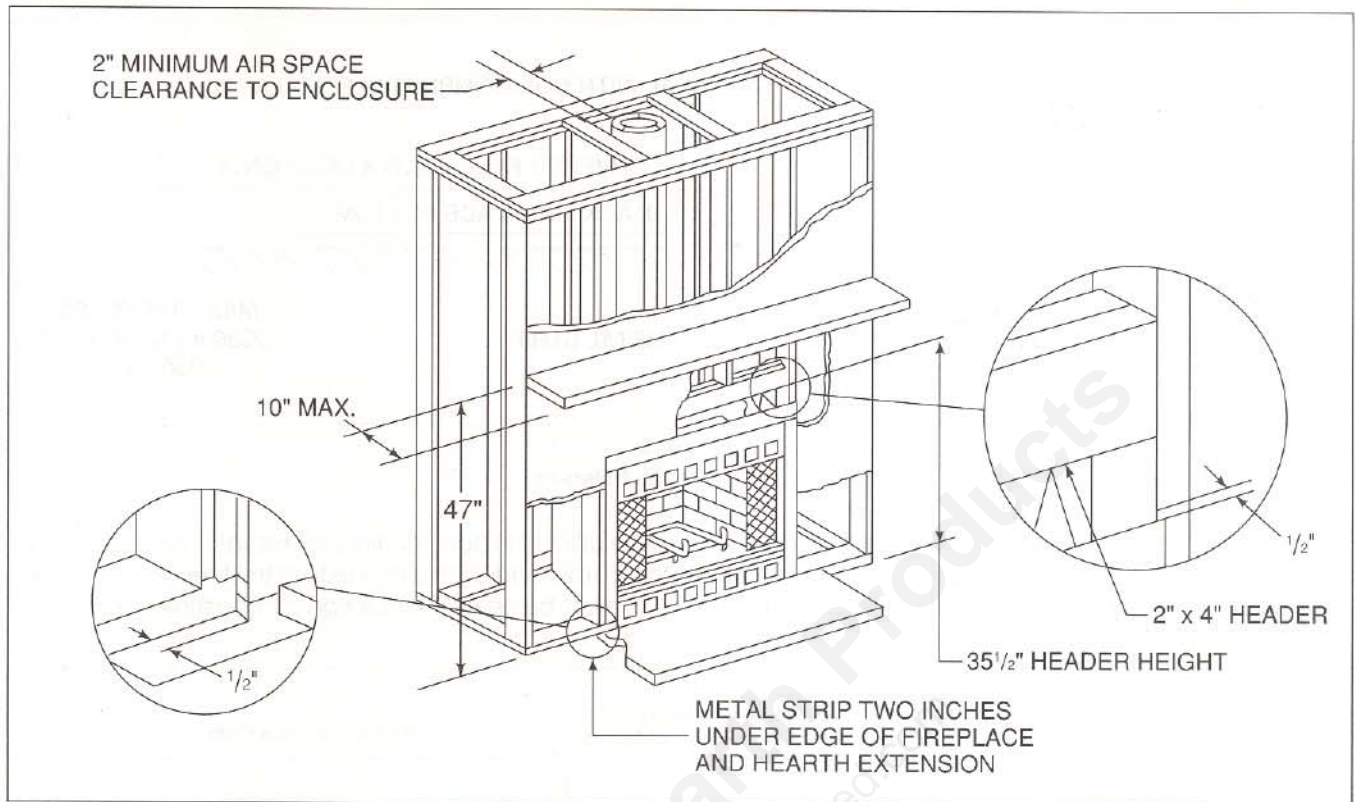
**WHEN LOCATING THE FIREPLACE IN A SPACE PROJECTING INTO A GARAGE, THE OUTSIDE AIR MUST NOT BE TAKEN FROM THE GARAGE SPACE. EXHAUST PRODUCTS OF GASOLINE ENGINES ARE HAZARDOUS.**

**DO NOT INSTALL OUTSIDE AIR DUCTS SUCH THAT THE AIR MAY BE DRAWN FROM ATTIC SPACES, BASEMENTS, OR ABOVE THE ROOFING WHERE OTHER HEATING APPLIANCES OR FANS AND CHIMNEYS EXHAUST OR UTILIZE AIR. THESE PRECAUTIONS WILL REDUCE THE POSSIBILITY FOR SMOKING OR FLOW REVERSAL.**

Figure 4 shows a typical framing of the fireplace, assuming combustible materials are used. All required clearances to combustibles around the fireplace must be adhered to. Any enclosure on top of the fireplace must be above the top standoffs. Chimney Sections at any level require a minimum air space of two inches to the enclosure, including any framing, for the total chimney height.

#### WARNING

**TO PREVENT CONTACT WITH SAGGING OR LOOSE INSULATION, THE FIREPLACE MUST NOT BE INSTALLED AGAINST VAPOR BARRIERS OR EXPOSED INSULATION. LOCALIZED OVERHEATING COULD OCCUR AND A FIRE COULD RESULT.**



**Figure 4**  
Framing the Fireplace

After completing the framing and after applying the facing material over the framing, a non-combustible sealant, one-half inch wide maximum, must be used to close off any gaps at the top and sides between the fireplace and facing, to prevent cold air leaks.

#### WARNING

**DO NOT APPLY FINISH MATERIALS OVER THE BOTTOM AIR INLET SLOTS NEAR THE GLASS DOOR OPENING ON THE FACE OF THESE FIREPLACES. THIS WILL BLOCK THE FLOW OF COOLING AIR AND MAY CAUSE DANGEROUSLY HIGH TEMPERATURES ON COMBUSTIBLE SURFACES OR ON THE FIREPLACE ITSELF.**

Non-combustible materials may be used to cover the black non-louvered fireplace front, but must not restrict the air flow to or from the front of the unit in any manner. The following is a description of materials specified in these Instructions:

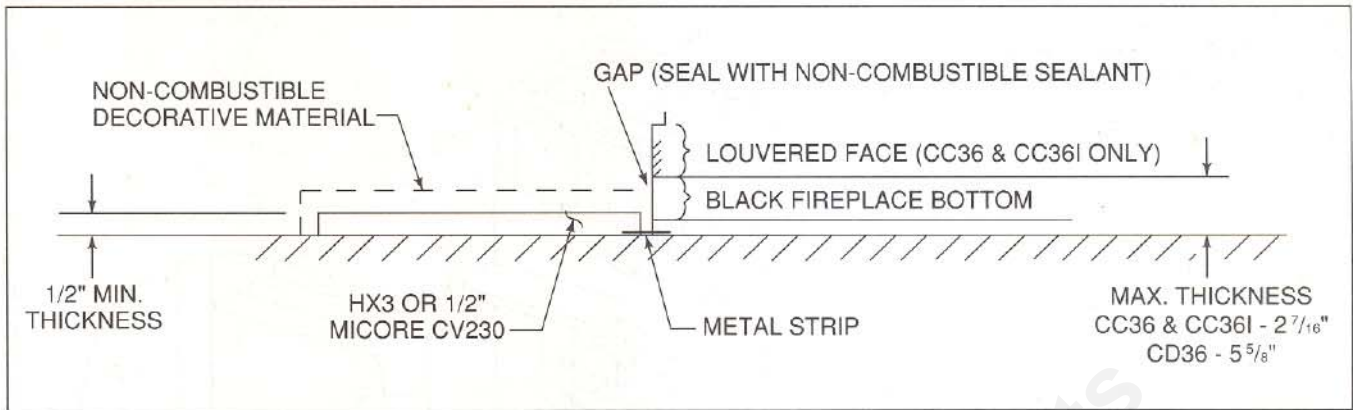
**Combustible Material.** Material made of or surfaced with wood, compressed paper, plant fibers, plastics, or other material that will ignite and burn, whether flameproofed or not, or whether plastered or unplastered.

**Non-combustible Material.** Material which will not ignite and burn, such materials consisting entirely of steel, iron, brick, tile, concrete, slate, asbestos, glass or plasters, or combination thereof.

**Non-combustible Sealant Material.** General Electric RTV103 (Black), or equivalent. Rutland, Inc. Fireplace Mortar #63, or equivalent.

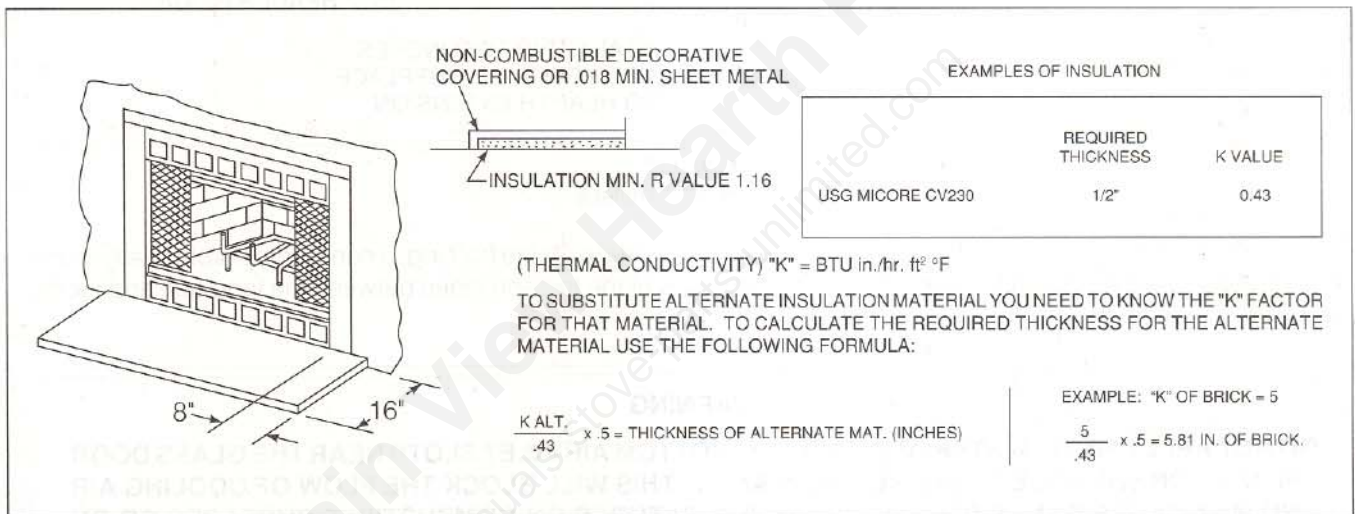
#### HEARTH EXTENSIONS

A Hearth Extension must be installed in front of the fireplace opening to protect the combustible floor in front of the fireplace. The Hearth Extension must not block the lower fireplace louvered face. See Figure 5. The Hearth Extension must have a minimum thickness of 1/2 inch and can have a maximum thickness of 2 7/16 inches for the CC36 and CC36I, and 5 5/8 inches for the CD36.



**Figure 5**  
Factory-Built Hearth Extension

Figure 6 provides alternate construction techniques that may be utilized in constructing the Hearth Extension. In all cases, the Hearth Extension must extend at least 16 inches to the front and 8" on either side of the fireplace opening. All gaps between the Hearth Extension and the fireplace front must be sealed with a non-combustible sealant.



**Figure 6**

**WARNING**

**HEARTH EXTENSIONS ARE TO BE INSTALLED ONLY AS ILLUSTRATED TO PREVENT HIGH TEMPERATURES FROM OCCURRING ON CONCEALED COMBUSTIBLE MATERIALS. METAL STRIPS PREVENT BURNING OR HOT PARTICLES FROM INADVERTENTLY FALLING DIRECTLY ON COMBUSTIBLE SURFACES IN THE EVENT THE BUILDING SHOULD SETTLE AND DISTURB THE ORIGINAL CONSTRUCTION.**

**SIDEWALLS/SURROUNDS**

Adjacent combustible side walls must be located a minimum of 18" from the fireplace opening. See Figure 7. If using a decorative surround of combustible material, it must be located within the shaded angle area defined in Figure 7. Short stub walls are also acceptable if they are contained in the shaded area.

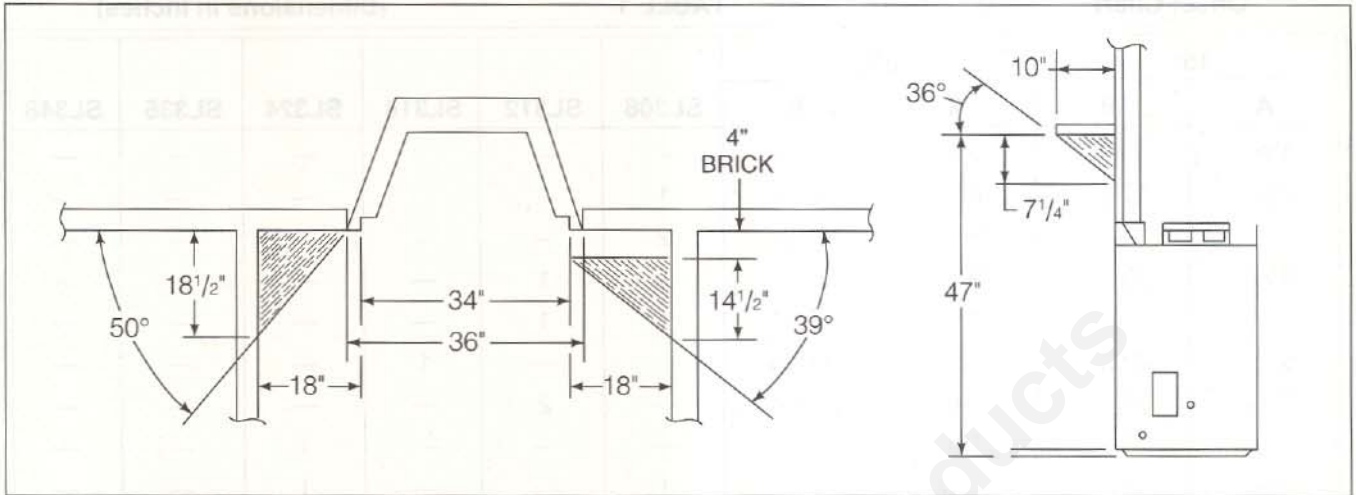


Figure 7

**MANTEL**

A mantel of combustible material may be installed no less than 47" above the platform or floor upon which the fireplace is located. The mantel may extend no more than 10" from the wall. Decorative combustible materials, such as a surround or mantel support brackets may be located within the shaded area defined in Figure 7. Mantels of depths less than 10" can be located at lower heights if the entire mantel is contained within the shaded area.

**IV. CHIMNEY REQUIREMENTS**

When planning your fireplace location, the chimney construction and necessary clearance must be considered. The fireplace system and chimney components have been tested to provide the following flexibility in construction.

Minimum straight height	12 ft.
Minimum height with Offset/Return	14 ft.
Maximum height	90 ft.
Maximum chimney length between an Offset/Return	8 ft.
Maximum distance between Chimney Stabilizers	35 ft.
Double Offset/Return minimum height	24 ft.
Maximum unsupported chimney length between Offset/Return	6 ft.
Maximum straight unsupported chimney height above firebox	25 ft.

**OFFSET INSTALLATIONS**

To clear any overhead obstructions, the chimney may be offset using a 15° Offset/Return, Catalog Number SL315, or 30° Offset/Return, Catalog Number SL330. Figure 8 and Table 1 enable selection of the appropriate chimney components when using Offsets and Returns.

1. Determine amount of offset required to extend the chimney through a wall or around an obstacle. See Figure 8, dimension "A".
2. Refer to Table 1 and find the "A" dimension closest to but not less than the amount of offset required in your installation.

**WARNING**

**DO NOT COMBINE OFFSETS TO CREATE AN OFFSET GREATER THAN 30° FROM VERTICAL. THIS MAY CREATE A FIRE HAZARD SINCE THE NATURAL DRAFT MAY BE RESTRICTED.**

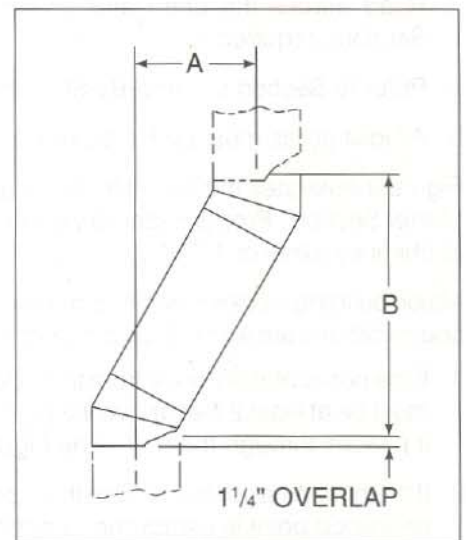


Figure 8  
Chimney Offset/Return

## Offset Chart

TABLE 1

(Dimensions in Inches)

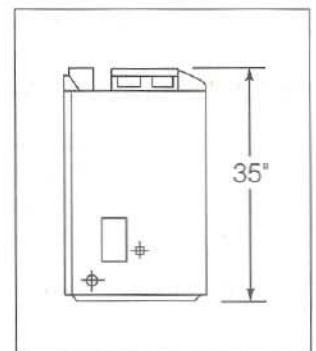
15°		30°		SL306	SL312	SL318	SL324	SL336	SL348
A	B	A	B						
1 <sup>5</sup> / <sub>8</sub>	13 <sup>3</sup> / <sub>8</sub>	3 <sup>7</sup> / <sub>8</sub>	14 <sup>7</sup> / <sub>16</sub>	—	—	—	—	—	—
2 <sup>7</sup> / <sub>8</sub>	17 <sup>3</sup> / <sub>4</sub>	6 <sup>1</sup> / <sub>4</sub>	18 <sup>9</sup> / <sub>16</sub>	1	—	—	—	—	—
—	—	8 <sup>5</sup> / <sub>8</sub>	22 <sup>11</sup> / <sub>16</sub>	2	—	—	—	—	—
4 <sup>7</sup> / <sub>16</sub>	23 <sup>9</sup> / <sub>16</sub>	9 <sup>1</sup> / <sub>4</sub>	23 <sup>3</sup> / <sub>4</sub>	—	1	—	—	—	—
—	—	11 <sup>5</sup> / <sub>8</sub>	27 <sup>7</sup> / <sub>8</sub>	1	1	—	—	—	—
6	29 <sup>3</sup> / <sub>8</sub>	12 <sup>1</sup> / <sub>4</sub>	28 <sup>15</sup> / <sub>16</sub>	—	—	1	—	—	—
7 <sup>3</sup> / <sub>16</sub>	34	14 <sup>5</sup> / <sub>8</sub>	33 <sup>1</sup> / <sub>16</sub>	—	2	—	—	—	—
—	—	15 <sup>1</sup> / <sub>4</sub>	34 <sup>1</sup> / <sub>8</sub>	—	—	—	1	—	—
—	—	17 <sup>5</sup> / <sub>8</sub>	38 <sup>1</sup> / <sub>4</sub>	1	—	—	1	—	—
—	—	20 <sup>5</sup> / <sub>8</sub>	43 <sup>7</sup> / <sub>16</sub>	—	—	2	—	—	—
10 <sup>5</sup> / <sub>8</sub>	46 <sup>3</sup> / <sub>4</sub>	21 <sup>1</sup> / <sub>4</sub>	44 <sup>9</sup> / <sub>16</sub>	—	—	—	—	1	—
11 <sup>7</sup> / <sub>8</sub>	51 <sup>3</sup> / <sub>8</sub>	23 <sup>5</sup> / <sub>8</sub>	48 <sup>11</sup> / <sub>16</sub>	1	—	—	—	1	—
—	—	26 <sup>5</sup> / <sub>8</sub>	53 <sup>13</sup> / <sub>16</sub>	—	—	—	2	—	—
13 <sup>3</sup> / <sub>4</sub>	58 <sup>3</sup> / <sub>8</sub>	27 <sup>1</sup> / <sub>4</sub>	55 <sup>3</sup> / <sub>4</sub>	—	—	—	—	—	1
15	62 <sup>15</sup> / <sub>16</sub>	29 <sup>5</sup> / <sub>8</sub>	59 <sup>1</sup> / <sub>16</sub>	1	—	—	—	—	1
16 <sup>1</sup> / <sub>2</sub>	68 <sup>3</sup> / <sub>4</sub>	32 <sup>5</sup> / <sub>8</sub>	64 <sup>1</sup> / <sub>4</sub>	—	1	—	—	—	1
18 <sup>1</sup> / <sub>16</sub>	74 <sup>9</sup> / <sub>16</sub>	35 <sup>5</sup> / <sub>8</sub>	69 <sup>7</sup> / <sub>16</sub>	—	—	1	—	—	1
—	—	38 <sup>5</sup> / <sub>8</sub>	74 <sup>5</sup> / <sub>8</sub>	—	—	—	1	—	1
—	—	41	78 <sup>3</sup> / <sub>4</sub>	1	—	—	1	—	1
22 <sup>3</sup> / <sub>4</sub>	91 <sup>7</sup> / <sub>8</sub>	44 <sup>5</sup> / <sub>8</sub>	85 <sup>1</sup> / <sub>16</sub>	—	—	—	—	1	1
24	96 <sup>1</sup> / <sub>2</sub>	47	89 <sup>1</sup> / <sub>8</sub>	1	—	—	—	1	1
25 <sup>7</sup> / <sub>8</sub>	103 <sup>1</sup> / <sub>2</sub>	50 <sup>5</sup> / <sub>8</sub>	95 <sup>7</sup> / <sub>16</sub>	—	—	—	—	—	2

- Find the "B" dimension in Table 1 and determine if it is compatible with your installation.
- Read across the chart and find the Catalog Number and number of Chimney Sections required.
- Refer to Section V., Step-By-Step Installation of the Fireplace System.
- All joist areas must be Firestopped.

Figure 9 illustrates the height from the bottom of the fireplace to the top of the Chimney Starter Section. Proper assembly of Air Cooled Chimney Sections results in an overlap at chimney joints of 1 1/4".

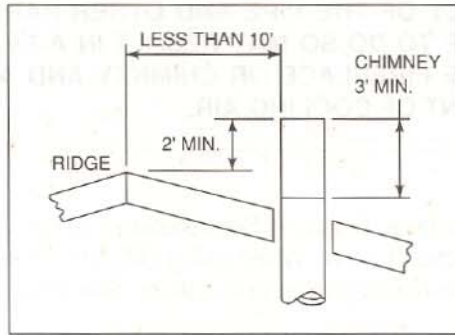
Major building codes specify a minimum chimney height above the roof top. These specifications are summarized in what is known as the "Ten Foot Rule". This rule states:

- If the horizontal distance from the side of the chimney to the peak of the roof is 10 feet or less, the top of the chimney must be at least 2 feet above the peak of the roof, but never less than 3 feet in height above the highest point where it passes through the roof. See Figure 10.
- If the horizontal distance from the side of the chimney to the peak of the roof is more than 10 feet, a chimney height reference point is established on the surface of the roof a distance of 10 feet from the side of the chimney in a horizontal plane. The top of the chimney must be at least 2 feet above this reference point, but never less than 3 feet in height above the highest point where it passes through the roof. See Figure 11.

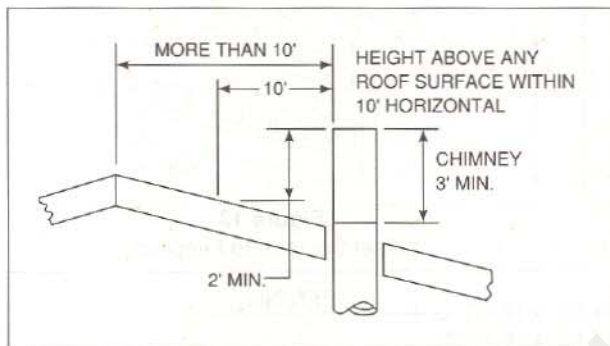


**Figure 9**  
Fireplace (Side View)

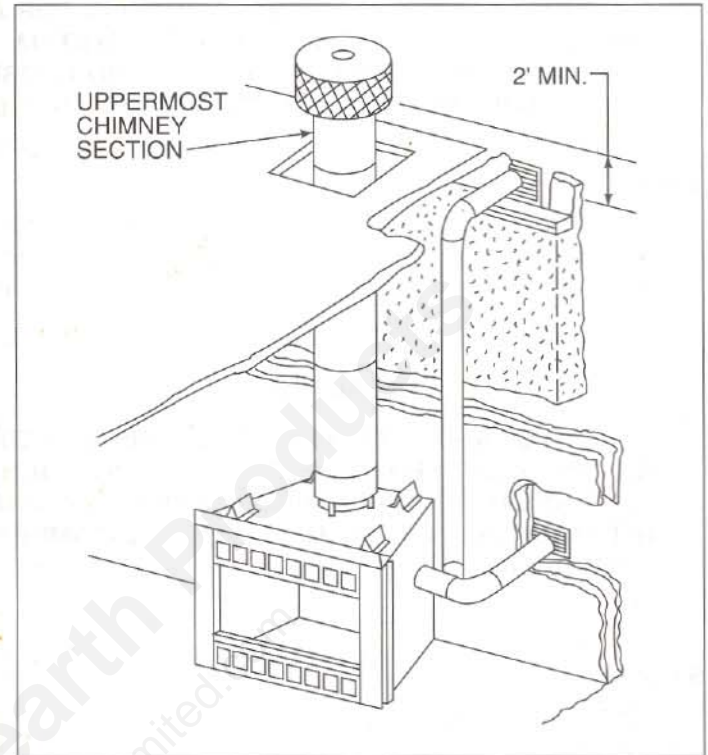
These chimney heights are necessary in the interest of safety and do not assure smoke-free operation. Trees, buildings, adjoining roof lines, adverse wind conditions, etc., may require a taller chimney should smoking occur.



**Figure 10**  
Chimney Height



**Figure 11**  
Chimney Height



**Figure 12**  
Outside Air Locations

If Outside Combustion Air is used, Figure 12 illustrates only two of many possible locations - a basement fireplace with a vertical outside air arrangement, and a horizontal, direct exit from the fireplace side.

**NOTE: A 2' minimum height difference must be maintained from the top of the uppermost Chimney Section to the Outside Combustion Air inlet.**

## V. STEP-BY-STEP INSTALLATION OF THE FIREPLACE SYSTEM

### WARNING

**BEFORE STARTING, DO THE FOLLOWING:**

- 1. WEAR GLOVES AND SAFETY GLASSES FOR PROTECTION.**
- 2. KEEP HAND TOOLS IN GOOD CONDITION. SHARPEN CUTTING EDGES AND MAKE SURE TOOL HANDLES ARE SECURE.**
- 3. ALWAYS MAINTAIN THE MINIMUM AIR SPACE REQUIRED TO THE ENCLOSURE TO PREVENT FIRE.**

#### STEP 1

Position the fireplace in the desired location and frame.

#### STEP 2

Slide the metal strip two inches under the front edge of the fireplace. See Figure 4. When the metal strip is not provided as a single piece, then the individual pieces must overlap each other by one inch.

#### STEP 3

Level the fireplace side-to-side and front-to-back. Shim with non-combustible material as necessary. Secure the fireplace by utilizing the nailing flanges located on either side of the fireplace.

### WARNING

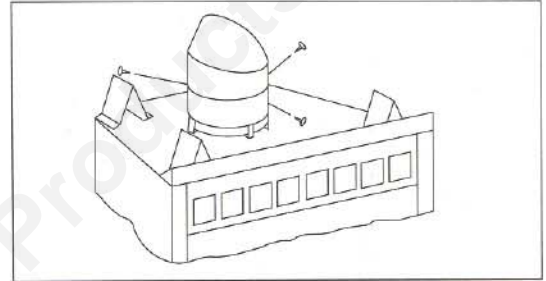
**CAREFULLY FOLLOW THE INSTRUCTIONS FOR ASSEMBLY OF THE PIPE AND OTHER PARTS NEEDED TO INSTALL THIS FIREPLACE SYSTEM. FAILURE TO DO SO MAY RESULT IN A FIRE, ESPECIALLY IF COMBUSTIBLES ARE TOO CLOSE TO THE FIREPLACE OR CHIMNEY AND AIR SPACES ARE BLOCKED PREVENTING THE FREE MOVEMENT OF COOLING AIR.**

#### STEP 4

Assemble either a straight Pipe Section or an Offset to the top of the fireplace. Chimney Sections are locked together by pushing downward until the section meets the stop bead on the section below. When using Offsets/Returns, the Offset and Return sections should be secured in place with screws to insure proper orientation. See Figure 13.

### CAUTION

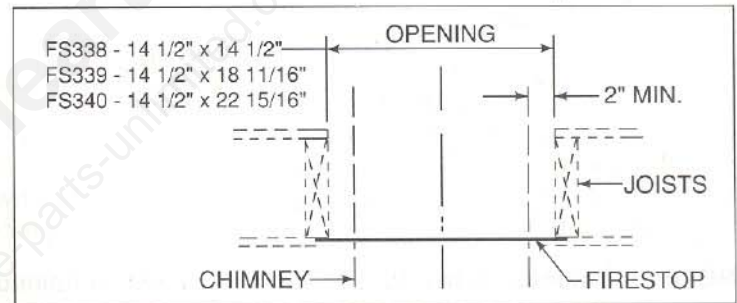
**INNER FLUE AND OUTER LINER SECTIONS CANNOT BE DISASSEMBLED ONCE LOCKED TOGETHER. PLAN AHEAD TO INSURE PROPER INSTALLATION HEIGHT IS ACHIEVED WITH THE SELECTED CHIMNEY COMPONENTS.**



**Figure 13**  
Offset Secured to Fireplace

#### STEP 5

Mark and cut out an opening in the ceiling for the particular Firestop Spacer being utilized (14 1/2" x 14 1/2" for an FS338, 14 1/2" x 18 11/16" for an FS339, or 14 1/2" x 22 15/16" for an FS340). Frame the opening with the same size lumber used in the ceiling joists. See Chapter 25 of the Uniform Building Code for general construction requirements when "Framing Around Openings".



#### STEP 6

Install the Firestop Spacer FS338 (Straight), FS339 or FS340 (15° or 30° Offset, if offset is located in the ceiling joist area). Nail the four sides of the Firestop to the joists using a minimum of (3) nails per side. These Firestop Spacers are designed to provide the minimum two inch air space around the chimney. In all situations, the Firestops are to be nailed to the ceiling joists from the bottom or fireplace side, EXCEPT, when the space above the ceiling is an attic space. In this situation, the Firestop must be nailed from the attic side to ensure against loose or later blow-in type insulation from falling into the required two inch air space around the chimney. Firestop Spacers must be used at all ceiling levels where the chimney penetrates a living space.

**NOTE: Nails must always be driven so the nail head is in shear (shank is perpendicular to the chimney load). This will prevent the nail from pulling loose.**

#### STEP 7

Continue assembling Chimney Sections up through the Firestop Spacers as needed. Check height and unsupported chimney length limitations described earlier.

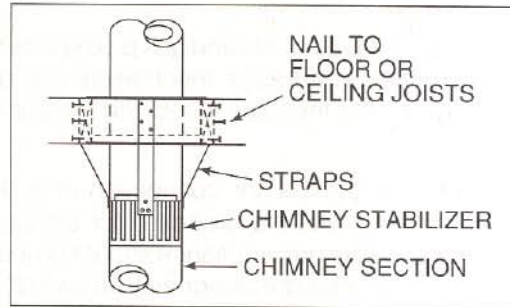
The maximum straight unsupported height is 25 feet above the firebox and 35 feet between Chimney Stabilizers (SL3).

#### STEP 8

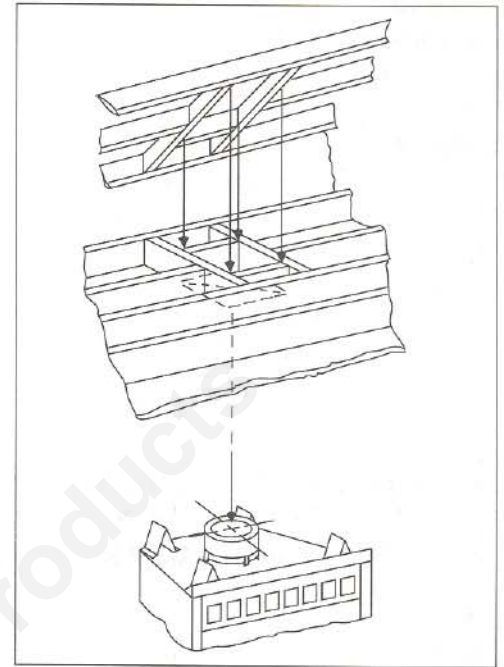
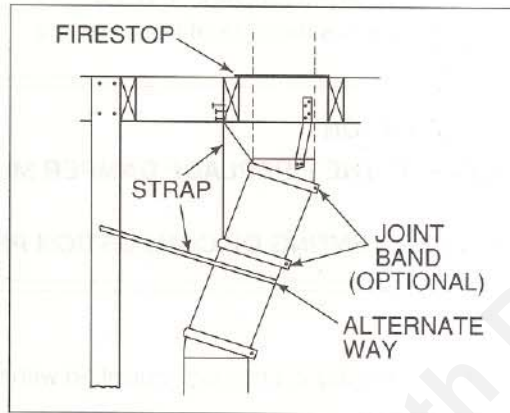
When Offsets/Returns are joined to straight Pipe Sections, they must be locked in position with the size 10 sheet metal screws provided, using the predrilled holes. Offsets/Returns and Chimney Stabilizers have straps for securing these parts to joists or rafters. Plumbers tape may be purchased locally and used in conjunction with Joint Bands to secure the chimney as an alternate method. Chimney Brackets may be used to stabilize the chimney. See Figures 14 & 15.

**NOTE: Be sure to provide intermediate support for the pipe during construction and check to be sure inadvertent loading has not dislodged the Pipe from the fireplace or at any chimney joint.**

**Figure 14**  
Chimney with Stabilizer



**Figure 15**  
Offset/Return Installation



**Figure 16**  
Ceiling and Attic Construction

**WARNING**

**WHEN CHIMNEY SECTIONS EXCEEDING 6 FEET IN LENGTH ARE INSTALLED BETWEEN AN OFFSET/RETURN, STRUCTURAL SUPPORT MUST BE PROVIDED TO REDUCE OFF-CENTER LOADING AND PREVENT CHIMNEY SECTIONS FROM SEPARATING AT THE CHIMNEY JOINTS.**

- STEP 9**  
Locate the point where the chimney will exit the roof by plumbing down to the center of the chimney. Drive a nail through the roof to mark the center. See Figure 16.
- STEP 10**  
Measure to either side of the nail and mark the 14 1/2" x 14 1/2" opening required. This 14 1/2" x 14 1/2" is measured on the horizontal; actual length may be larger depending on the pitch of the roof. Cut out and frame the opening. See Chapter 25 of the Uniform Building Code for Roof Framing details.
- STEP 11**  
Continue to add Chimney Sections through the roof opening, maintaining a minimum 2" air clearance.
- STEP 12**  
Install the Roof Flashing appropriate to the roof pitch and install one of these Terminal Caps: RT362 or RT382 (Telescoping-Round), RT364 or RT384 (Round), or RT364S (Stainless Steel-Round) following the Instructions shipped with these accessories. The Terminal Cap may also be a ST8 (Housing Top and Flashing) utilizing RB4, TB4, RB6 or TB6 Simulated Brick Panels and installed in accordance with the Instructions shipped with these accessories. For flat roof pitch installations, Terminal Caps ST375 (Square) or ST376 (Telescoping-Square) may be installed utilizing a Chase Top.

**WARNING**

**DETAIL INSTRUCTIONS FOR INSTALLATION OF THE ROOF FLASHING, STORM COLLAR AND TERMINAL CAP ARE FOUND PACKAGED WITH THESE PARTS. TO AVOID DANGER OF FIRE, ALL INSTRUCTIONS MUST BE STRICTLY FOLLOWED, INCLUDING THE PROVISION OF AIR SPACE CLEARANCE BETWEEN CHIMNEY SYSTEM AND COMBUSTIBLE ENCLOSURE. TO PROTECT AGAINST EFFECTS OF METAL CORROSION OF THE ABOVE PARTS, FIRST WASH THEM WITH A SOLVENT OR VINEGAR, RINSE WITH WATER, AND THEN PAINT WITH A RUST RESISTANT PAINT.**

**STEP 13**

Complete the fireplace enclosure, allowing space for outside air ducts and gas piping if desired. Care must be taken with any electrical wiring to avoid exposure to high temperatures or mechanical damage to wire insulation. A minimum clearance of 1/2" must be maintained between the fireplace sides and the combustible enclosure.

**STEP 14**

Knockouts are provided on both sides of the fireplace to allow for connection of a decorative gas appliance incorporating an automatic shutoff device and complying with the Standard for Decorative Gas Appliances for Installation in Vented Fireplaces, ANSI Z21.60. The decorative gas appliance should be installed in accordance with the National Fuel Code, ANSI Z223.1-1980. The side refractories are designed to allow 1/2" iron pipe to pass through. Use a non-combustible sealant to seal any opening between the gas pipe and refractory on the inside. Repack the insulation removed, to seal around the gas pipe where it exits the side of the fireplace.

**CAUTION**

- 1. WHEN USING THE DECORATIVE APPLIANCE, THE FIREPLACE DAMPER MUST BE SET IN THE FULLY OPEN POSITION.**
- 2. A FULLY OPEN DAMPER ENSURES PROPER VENTING OF COMBUSTION PRODUCTS.**

**STEP 15**

Install Outside Air if desired or required by local code, using the Instructions supplied with the AK14 Air Kit. The use of Outside Air is strongly recommended.

**STEP 16**

If a Fan Kit is desired (CC36 and CC36I only), first complete installation of the Junction Box Kit (JK1), referring to the separate JK1 Instructions packaged with the Junction Box Kit. Fan Kits FK1 and FK2 can only be installed after the JK1 Junction Box Kit has been installed. Follow the Instructions supplied with the Fan Kits for proper installation. It is recommended to install the JK1 Junction Box Kit during initial construction even if fans are not initially desired - this allows for adding a Fan Kit at a later date.

**WARNING**

**DISCONNECT POWER BEFORE STRIPPING OR JOINING ANY SUPPLY WIRES. ONLY PERSONS QUALIFIED FOR MAKING ELECTRICAL INSTALLATIONS (ELECTRICIANS) AS RECOGNIZED BY LOCAL OR NATIONAL GOVERNMENTAL BODIES SHOULD ATTEMPT TO MAKE THE INCOMING SUPPLY WIRE CONNECTIONS.**

**EDGES ARE SHARP. HAND PROTECTION IS RECOMMENDED. RECHECK ALL FASTENERS BEFORE LEAVING JOB.**

**NOTE: A Motor Speed Control Kit, Catalog Number BC10, is available for use with this Fan Kit. Refer to the Instructions packed with it for proper installation. If a speed control option is desired, it is recommended to use the BC10 Kit to insure proper function.**

**STEP 17**

Attach the firescreen to the fireplace side, utilizing the (2) hairpin clips from the enclosed fastener package. Use pliers to insert the clip through the last strand of screen wire and into the hole at midpoint of the fireplace side.

**STEP 18**

Install Glass Doors if desired, using the Instructions supplied with these optional accessories. Protect Glass Doors from breakage by temporarily removing them until all construction is complete.

**STEP 19**

Position the Hearth Extension over the metal protective strip which should project about two inches in front of the fireplace bottom front. See Figure 4. Seal the crack between the Hearth Extension and fireplace with a non-combustible sealant.

**STEP 20**

Apply the finish materials of your choice. Do not install combustible materials over the black face of the fireplace or air inlet openings. You may use non-combustible material over the black face of the fireplace. Refer to Figure 8 for combustible surround information.

**STEP 21**

This fireplace is equipped with a factory installed Integral Grate. In the event it becomes necessary to replace it, slide the Grate to one side. Then on the opposite side, loosen the screws of the bracket holding down the side stone. Slide the bracket up and move the side stone forward until the back bar of the Grate clears the hub. To install the new Grate, do the reverse of the above instructions for removal. Use only Catalog Number GR36A00 Integral Grate for replacement.

**STEP 22**

Prior to building your first fire in your fireplace, please read the "Operating Instructions" section that follows.

**WARNING**

**DO NOT PACK REQUIRED AIR SPACES WITH INSULATION OR OTHER MATERIALS. THIS PREVENTS THE NATURAL CONVECTION COOLING WHICH MUST TAKE PLACE. THE REQUIRED CLEARANCES ARE TO THE ENCLOSURE AND SHOULD NOT BE REDUCED BY THE ADDITION OF OTHER MATERIALS WHETHER OF NON-COMBUSTIBLE OR COMBUSTIBLE MATERIAL. COMBUSTIBLE MATERIALS AS WELL AS THE NON-COMBUSTIBLE MATERIALS USED IN THE FIREPLACE MAY HAVE THEIR USEFUL LIFE REDUCED.**

**VI. CONSTRUCTING THE CHASE**

The chase may be constructed for the fireplace and chimney or for the chimney only. A chase is an enclosure built around the system. It is most commonly constructed on an outside wall as shown below.

Three examples of chase applications are shown in Figure 17.

1. Fireplace and chimney enclosed in chase - exterior.
2. Chimney offset through exterior wall and enclosed in chase.
3. Chase constructed on roof.



**Figure 17**  
Chase Constructions

**MATERIALS FOR CHASE**

The chase is constructed much the same as the walls in your home. A variety of materials may be used including brick, stone, veneer brick, or standard siding materials.

In constructing the chase, several factors must be considered.

1. Maintain a 2" air space clearance around the chimney.
2. The Chase Top must be constructed of a non-combustible material.
3. The walls of the chase must be insulated to prevent heat leaking from the home around and through the fireplace.

**TO INSTALL TERMINAL CAP ON CHASE - ENCLOSED CHIMNEY**

1. Construct chase of desired materials maintaining a minimum 2" air space around the chimney.

### WARNING

**NEVER INSTALL A SINGLE WALL SLIP SECTION OR SMOKE-PIPE IN A CHASE STRUCTURE. THE HIGHER TEMPERATURE OF THIS SINGLE WALL PIPE MAY RADIATE SUFFICIENT HEAT TO COMBUSTIBLE CHASE CONSTRUCTION MATERIALS TO CAUSE A FIRE.**

2. Install the Chimney Sections up through the chase. When using a Round Terminal Cap (RT364, RT364S or RT384), the last section of Pipe must extend above the Chase Top to allow installation of the Storm Collar and Terminal Cap. For installations utilizing a Telescoping Round Terminal Cap (RT362 or RT382), Square Terminal Cap (ST375), or Telescoping Square Terminal Cap (ST376), the last Chimney Section must be below the top of the Chase Top, but not more than 18" below the Chase Top. For installations utilizing a Square Terminal Cap (ST375), the last Chimney Section must not be more than 4 3/4" below the base of the Chase Top. See Figure 18.
3. Attach the Chase Top (CT35) to the top of the Chase.
4. Install the Terminal Cap, using the Instructions packaged with it.

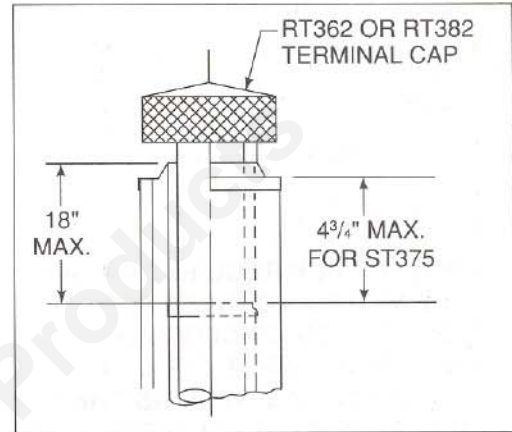


Figure 18

### WARNING

**DETAIL INSTRUCTIONS FOR INSTALLATION OF THE CHASE TOP, STORM COLLAR AND TERMINAL CAP ARE FOUND PACKAGED WITH THESE PARTS. TO AVOID DANGER OF FIRE, ALL INSTRUCTIONS MUST BE STRICTLY FOLLOWED, INCLUDING THE PROVISION OF AIR SPACE CLEARANCE BETWEEN CHIMNEY SYSTEM AND COMBUSTIBLE ENCLOSURE. TO PROTECT AGAINST EFFECTS OF METAL CORROSION OF PARTS SUCH AS CHASE TOP AND THOSE ABOVE CHASE TOP, FIRST WASH THEM WITH A SOLVENT OR VINEGAR, RINSE WITH WATER, AND THEN PAINT WITH A RUST RESISTANT PAINT.**

## OPERATING INSTRUCTIONS

### NOTICE

**SAVE AND PASS THESE OPERATING INSTRUCTIONS AND THE INSTALLATION INSTRUCTIONS TO SUBSEQUENT OWNERS. THE INFORMATION PROVIDED IS INTENDED TO NOTIFY AND WARN THEM ABOUT MAKING FUTURE UNSAFE MODIFICATIONS SUCH AS THE ADDITION OF SHELVES OR THE USE OF UNAUTHORIZED PARTS AND REPAIRS.**

### CAUTION

**EDGES ARE SHARP. HAND PROTECTION IS RECOMMENDED.**

Before starting a fire in your new or existing fireplace, use the following check list:

- A. FLUE DAMPER.** The flue damper is operated by moving the handle to the right, which should place the damper in the full open position. Verify by looking up from the inside of the firebox. Always operate this fireplace with the damper fully open. Please note, downdrafts, obstructions, damage or poor (wet) fuels can cause spillage.

## WARNING

**DO NOT OPERATE THE FIREPLACE WITH THE DAMPER RESTRICTED OR PARTIALLY CLOSED. THIS CAN RESULT IN SEVERE OVERTEMPERATURES AND POSSIBLE FIRE. THE FIREPLACE MUST BE OPERATED WITH THE DAMPER IN THE FULL OPEN POSITION.**

**B. CHIMNEY INSPECTION.** Visually inspect the chimney internally for obstructions and construction damage. Flue pipe joints and seams must be continuous and mechanically tight. In a used chimney, additional inspection is needed for the following:

“Creosote - Formation and Need for Removal.

When wood is burned slowly, it produces tar and other organic vapors, which combine with expelled moisture to form creosote. The creosote vapors condense in the relatively cool chimney flue of a slow-burning fire. As a result, creosote residue accumulates on the flue lining. When ignited, this creosote makes an extremely hot fire.

The chimney should be inspected at least twice a year during the heating season to determine if creosote build-up has occurred.

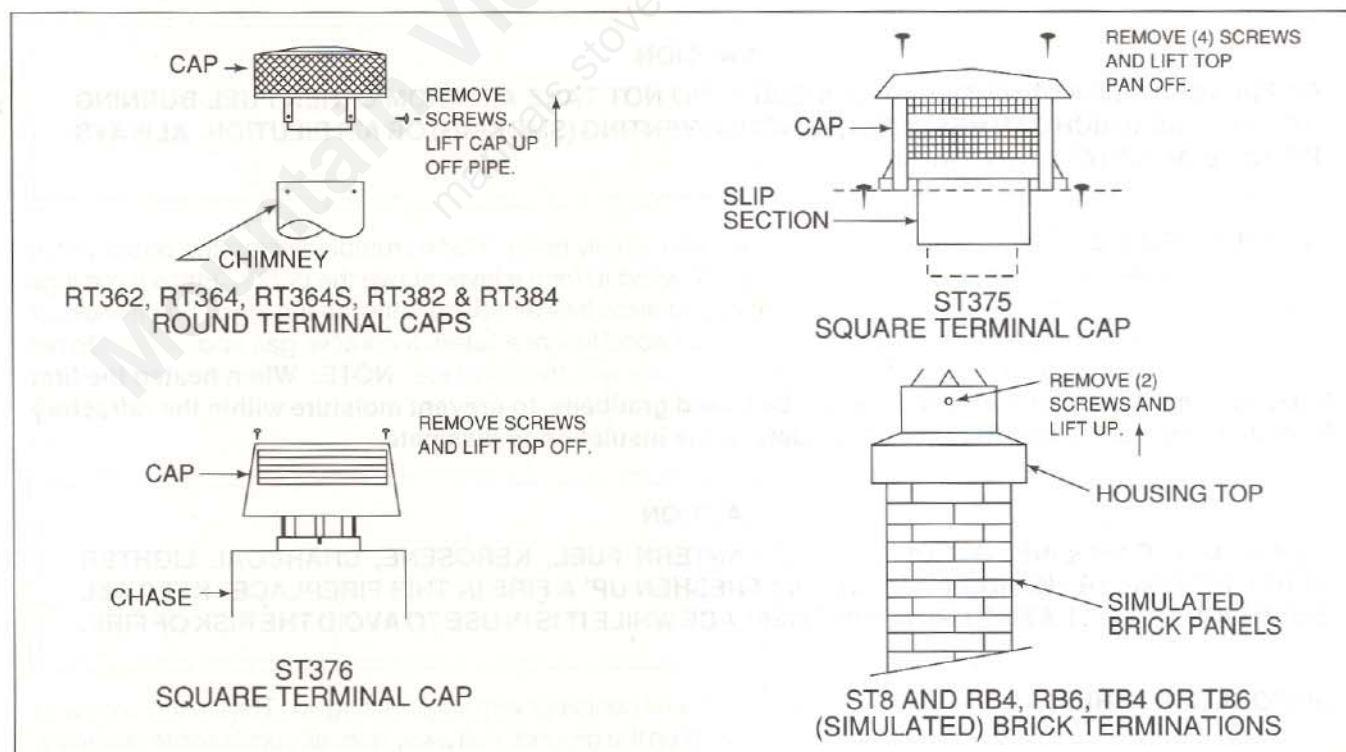
If creosote has accumulated, it should be removed to reduce the risk of a chimney fire.”

**C. CHIMNEY CLEANING.** If you do detect a build-up of creosote, contact a qualified chimney sweep or clean it yourself.

1. Open the damper.
2. Hang a damp sheet across the fireplace opening to stop dirt and soot from entering the room.
3. Remove the Terminal Cap or Housing Top. See Figure 19.
4. Clean with a stiff bristled brush attached to a pole,

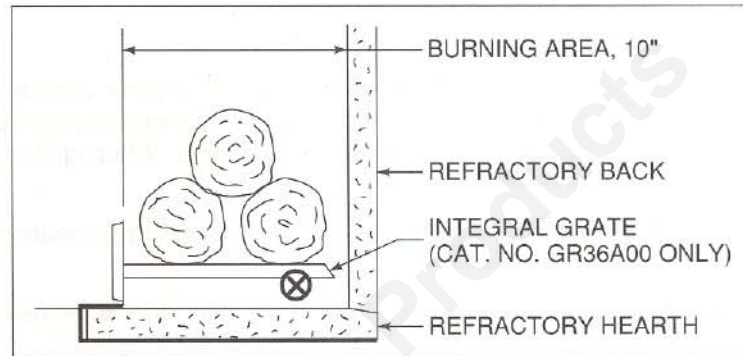
**OR**

- 4.A. Tie a rope to a burlap bag filled with straw and several small stones or sand. Work up and down the flue until clean.
5. Replace the Terminal Cap or Housing Top.



**Figure 19**  
Terminal Caps

- D. CLEAR SPACE NEAR FIREPLACE.** The Hearth Extension must extend at least 16 inches to the front and 8 inches on either side of the firebox opening. Combustible materials must not be stored in this area. Combustible walls perpendicular to the front of the fireplace must be at least 18 inches from the fireplace opening. Room furnishings such as drapes, curtains, chairs, or other combustibles must be at least 4 feet from the open front of the fireplace.
- E. GRATE.** The factory installed Integral Grate must be used to hold the logs from falling out of an open fireplace and to allow air to pass between the burning logs. It is important to keep the fire off the hearth and to allow the ashes to collect beneath the fire, thereby forming a layer of additional heat protection. See Figure 20. Use only Catalog Number GR36A00 Integral Grate for replacement.



**Figure 20**  
Section Through Fireplace

- F. FIRESCREEN.** A firescreen is always provided to control sparks. It must be closed whenever the fireplace is in use. Glass Doors or firescreens must not be used to hold burning material inside the fireplace as might occur when overfilling the fireplace with empty boxes or branches. Only those Glass Door units specifically tested and listed for use with the specific fireplace model should be used. Screens should be closed when the Glass Doors are closed.
- G. OUTSIDE AIR.** A damper allows individual control of the Outside Air inlets if your fireplace is equipped with this option. In a tightly sealed or well insulated home, replacement of combustion air is necessary to keep harmful gases from entering living spaces.

**CAUTION**

**FIREPLACE OPERATION DOES REQUIRE AIR. DO NOT TAKE AIR FROM OTHER FUEL BURNING APPLIANCES WHICH CAN RESULT IN IMPROPER VENTING (SMOKING) OR AIR DILUTION. ALWAYS PROVIDE ADEQUATE MAKE-UP AIR.**

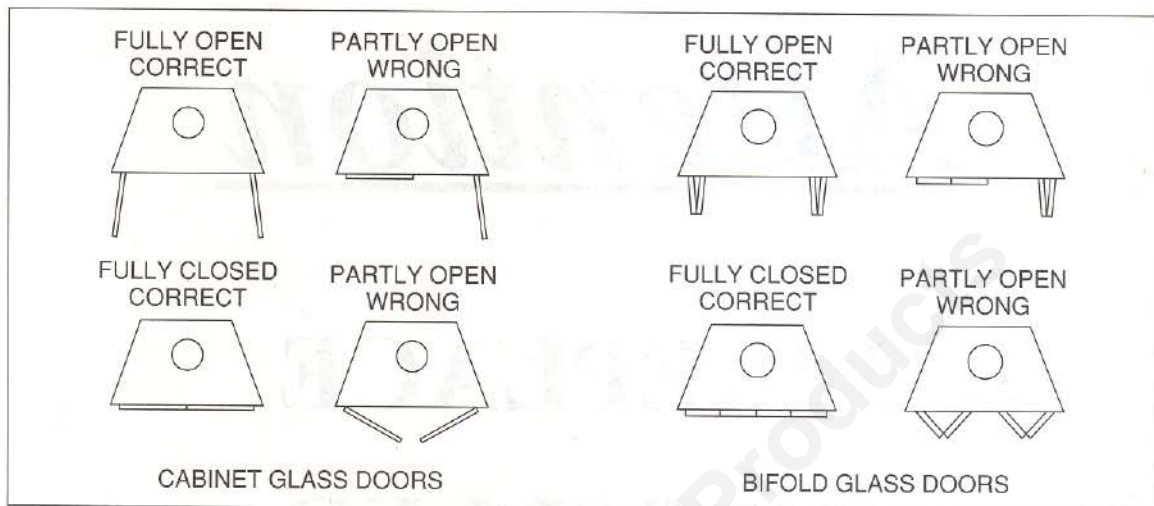
- H. SETTING THE FIRE.** Check the flue damper to be sure it is fully open. Place crumpled or twisted paper under the Grate. Loosely arrange kindling or small pieces of wood to form a layer above the paper. Place three logs in a rough pyramid as shown in Figure 20, being sure to allow free air space between the logs. Small sticks of wood may be used to separate the logs. Use only solid wood fuel or a listed decorative gas appliance. Do not use a fireplace insert or other products not specified for use with this fireplace. **NOTE: When heated the first time, the temperature of the fireplace must be raised gradually, to prevent moisture within the refractory from causing cracks, and to allow the binders in the insulation to dissipate.**

**CAUTION**

**NEVER USE GASOLINE, GASOLINE-TYPE LANTERN FUEL, KEROSENE, CHARCOAL LIGHTER FLUID, OR SIMILAR LIQUIDS TO START OR 'FRESHEN UP' A FIRE IN THIS FIREPLACE. KEEP ALL SUCH LIQUIDS WELL AWAY FROM THE FIREPLACE WHILE IT IS IN USE TO AVOID THE RISK OF FIRE.**

- I. DISPOSAL OF ASHES.** Ashes should be placed in a metal container with a tight-fitting lid. The closed container of ashes should be placed on a non-combustible floor or on the ground, well away from all combustible materials, pending final disposal. If the ashes are disposed of by burial in soil or otherwise locally dispersed, they should be retained in the closed container until all cinders have thoroughly cooled.

**J. GLASS DOORS.** Most efficient fireplace operation using Glass Doors is with the Doors open. When the fireplace is not in use, Glass Doors will prevent loss of room heat through the chimney. Only HEATILATOR® Glass Doors, Catalog Numbers GD36A, GD36B, GA36A, GA36B, C1136A, C1136B, C1136C, C2136A, C2136B, C2136C, D1136B and D2136B, may be used.



**Figure 21**  
Recommended Operating Positions of Doors

**WARNING**

**FIREPLACES EQUIPPED WITH DOORS SHOULD BE OPERATED ONLY WITH DOORS FULLY OPEN OR DOORS FULLY CLOSED. IF DOORS ARE LEFT PARTLY OPEN, GAS AND FLAME MAY BE DRAWN OUT OF THE FIREPLACE OPENING, CREATING RISKS OF BOTH FIRE AND SMOKE.**

**K. OPERATING YOUR FIREPLACE.**

**WARNING**

**CONTINUED OVERFIRING CAN PERMANENTLY DAMAGE YOUR FIREPLACE SYSTEM. EXAMPLES OF OVERFIRING ARE:**

- 1. QUANTITIES OF SCRAP LUMBER, PINE BRANCHES OR CARDBOARD BOXES WHICH EXCEED THE VOLUME OF THE "NORMAL LOG FIRE". THESE MATERIALS PRODUCE MANY SPARKS AND MUST NOT BE USED.**
- 2. THE "NORMAL LOG FIRE" IS THREE LOGS, EACH FOUR INCHES IN DIAMETER, WITH THE LENGTH NO GREATER THAN THE BACK WALL OF THE FIREPLACE. THE RATE OF FIRING MUST NOT EXCEED THESE THREE LOGS PER HOUR.**

**L. FAN KIT (CC36 AND CC36I ONLY).** HEATILATOR® FK1 and FK2 Heat Circulating Fans may be used with this fireplace. An external ON/OFF switch must be provided, or a Motor Speed Control BC10, may be used. Using these fans will increase efficiency and heat output.

**M. SAFETY - A FINAL WORD.** Fireplaces as well as other woodburning appliances have been used safely for many years. Our own experience is that most problems are caused by improper installation, fueling, and operating. All dimensions specified are minimum and increasing distances to combustibles decreases risk. Such common practices as surrounding the fireplace with loose fill insulation, and especially leaving the fire unattended, will increase the risk of fire. Additionally, an annual inspection of all fireplace systems should be performed as, like any appliance, minor repairs may be required to maintain the system in top operating condition.

# *Attention*

## **FIREPLACE INSTALLER**

***Please return these  
Operating & Installation  
Instructions to the  
Firebox  
for Consumer Use***

**heatilator®**  
*The first name in fireplaces*

Heatilator Inc.  
1915 W. Saunders Street  
Mt. Pleasant, IA 52641  
Division, HON INDUSTRIES  
319/385-9211 FAX 319/385-9225