

heatilator®

THE WOODBURNING SPECIALISTS

Heatilator Inc.
1915 W. Saunders Street
Mt. Pleasant, IA 52641
Division, HON INDUSTRIES

HF42A INSTALLATION & OPERATING INSTRUCTIONS FOR RESIDENTIAL USE

I. LISTINGS AND CODE APPROVALS

The HF42A fireplace system has been tested in accordance with Underwriters Laboratories Inc. Standards, and has been LISTED by them for installation and operation as described in these Instructions and in the Operating Instructions accompanying each fireplace.

Fireplace Catalog Number HF42A has been tested and LISTED for use with the Optional Components described in Section II of these Instructions. These Optional Components may be purchased separately and installed at a later date. However, installation of the Outside Air Kit and Fan Kit will require significant reconstruction, and should be installed at the time of initial installation.

Check with your local building code agency before you begin installation to ensure compliance with local codes, including the need for "permits" and follow-up inspections. If any problems are encountered regarding code approvals, or if you wish clarification of any of the instructions contained here, contact: Technical Services, Heatilator Inc., 1915 W. Saunders Street, Mt. Pleasant, Iowa 52641. HEATILATOR® is a registered trademark of Heatilator Inc., Division, HON INDUSTRIES.

WARNING

THIS HEATILATOR FIREPLACE AND ITS COMPONENTS ARE DESIGNED TO BE INSTALLED AND OPERATED AS A SYSTEM. ANY ALTERATION TO OR SUBSTITUTION FOR ITEMS IN THIS SYSTEM UNLESS ALLOWED BY THESE INSTALLATION INSTRUCTIONS WILL VOID THE UNDERWRITERS LABORATORIES LISTING AND MAY VOID THE PRODUCT WARRANTY. IT MAY ALSO CREATE A HAZARDOUS INSTALLATION. READ THROUGH THESE INSTRUCTIONS THOROUGHLY PRIOR TO STARTING YOUR INSTALLATION AND FOLLOW THEM CAREFULLY THROUGHOUT YOUR PROJECT.

II. DESCRIPTION OF THE FIREPLACE SYSTEM

The HEATILATOR® fireplace system consists of the following:

1. Fireplace
2. Hearth Extension
3. Chimney System
4. Roof Termination
5. Integral Grate

Optional components include:

1. Glass Doors
2. Outside Combustion Air System
3. Heat Circulating Fans

THE FIREPLACE SYSTEM COMPONENTS

The table below, together with the following pictures, show only those components which may be safely used with this fireplace.

Catalog Number		Description
HF42A HX42A GF42A GF42B GD42 GR42-2 FK25A BC10 AK42-A ID4 UD4		Fireplace Hearth Extension Glass Doors - Clear-View, Antique Solid Brass Glass Doors - Clear-View, Bright Solid Brass Glass Doors - Bifold, Antique Solid Brass Integral Grate (included with Fireplace) Fan Kit Motor Speed Control Kit Air Kit - Outside Air Insulated Duct/Outside Air Uninsulated Duct/Outside Air
Twist Lock	Snap Lock	
AC542 AC506 AC512 AC518 AC536 AC548 SZ5 OR531	SL542 SL506 SL512 SL518 SL536 SL548 SL5 SL531	Transition Section Chimney Section - 6 inch long Chimney Section - 12 inch long Chimney Section - 18 inch long Chimney Section - 36 inch long Chimney Section - 48 inch long Chimney Stabilizer Chimney Offset/Return - 30°
FS544 FS546 JB577 CB576 RF580 RF581 RT582 RT584 ST575 ST8 RB4 TB4 RB6 TB6 CT56		Firestop - Straight Firestop - 30° Chimney Joint Band Chimney Bracket Roof Flashing - Flat to 6/12 Pitch Roof Flashing - 6/12 to 12/12 Pitch Telescoping Chimney Terminal Cap - Round Chimney Terminal Cap - Round Chimney Terminal Cap - Square Housing Top Chimney Terminal Cap 4' Simulated Red Brick Chimney Panels 4' Simulated Tan Brick Chimney Panels 6' Simulated Red Brick Chimney Panels 6' Simulated Tan Brick Chimney Panels Chase Top

HF42A FIREPLACE

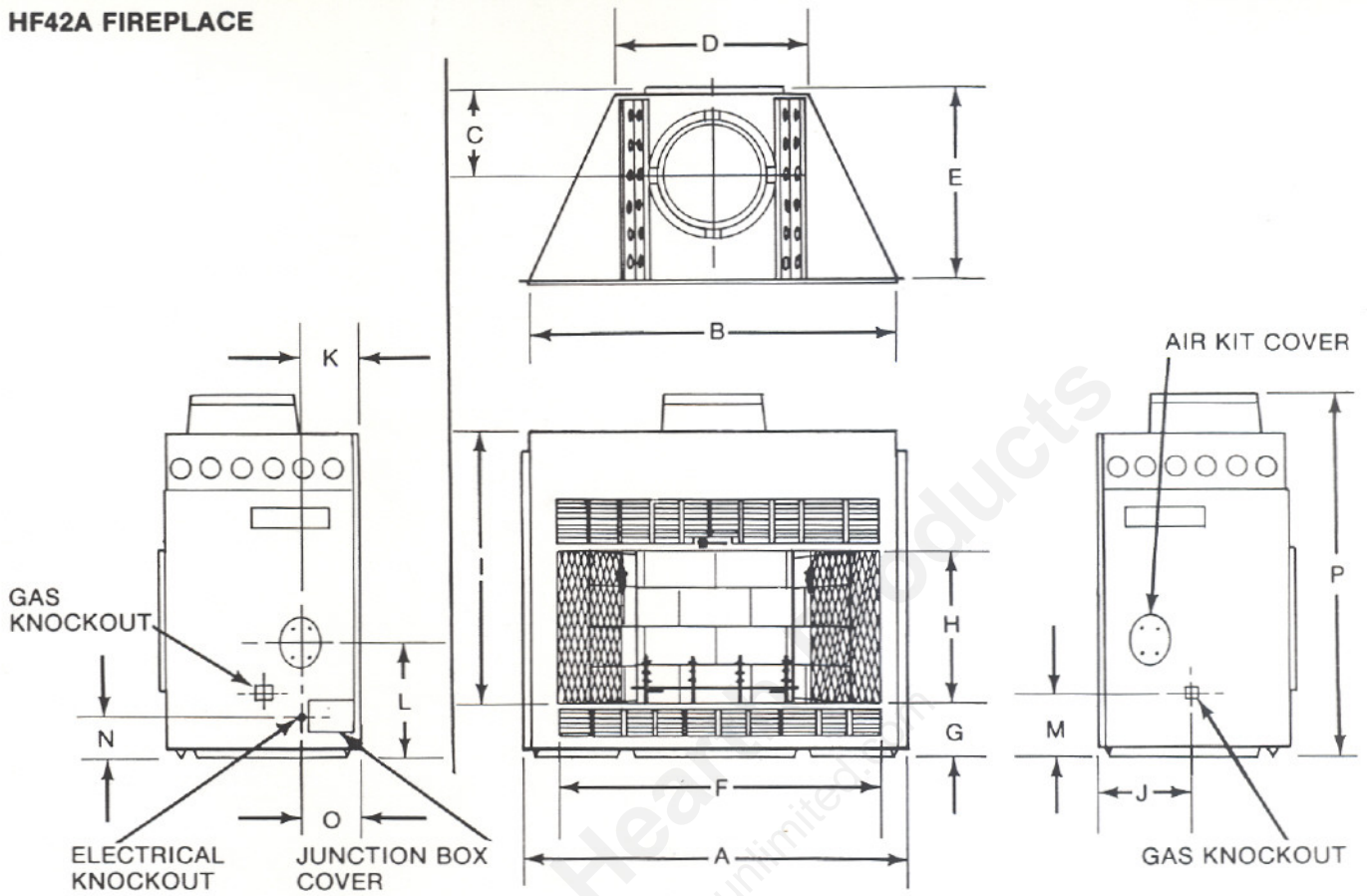

DIM.	A	B	C	D	E	F	G	H	I	J	K	L	M	N	O	P
INCHES	48 ¹ / ₃₂	46 ¹ / ₃₂	10 ¹ / ₂	24 ³ / ₈	24	42	6 ⁷ / ₃₂	19 ¹ / ₁₆	35 ⁵ / ₁₆	11 ²⁷ / ₃₂	7 ¹ / ₁₆	14 ¹ / ₃₂	7 ⁹ / ₃₂	4 ¹ / ₂	7 ¹ / ₄	45 ¹ / ₂

HEARTH EXTENSION

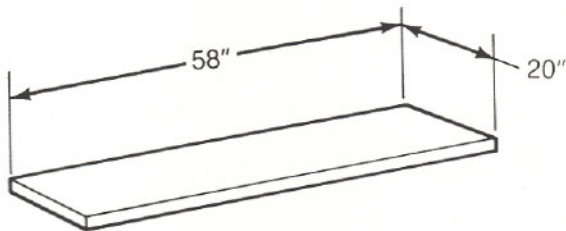

HX42A

GLASS DOORS

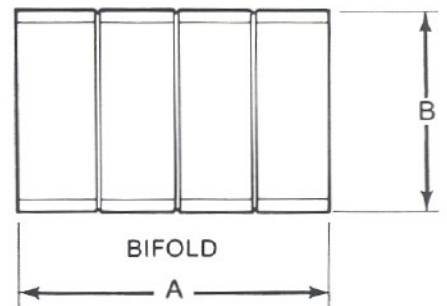

CAT. NO.	A	B
GF42A	40 ⁵ / ₁₆ "	18 ⁷ / ₁₆ "
GF42B	40 ¹ / ₁₆ "	18 ⁷ / ₁₆ "
GD42	41 ¹ / ₂ "	18 ¹ / ₂ "

INTEGRAL GRATE

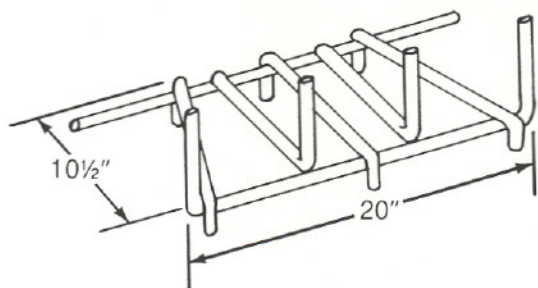

GR42-2

FAN KIT

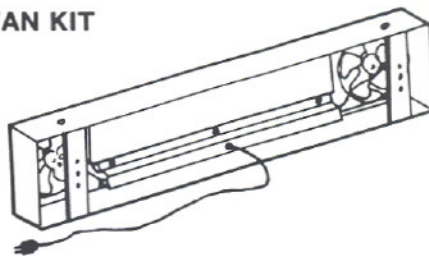

FK25A

AIR KIT

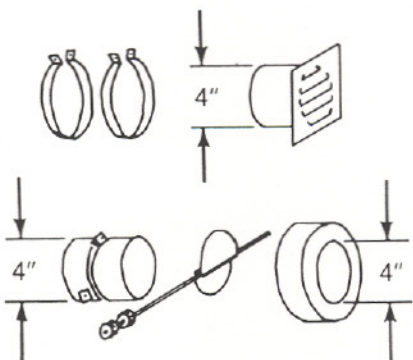

AK42-A

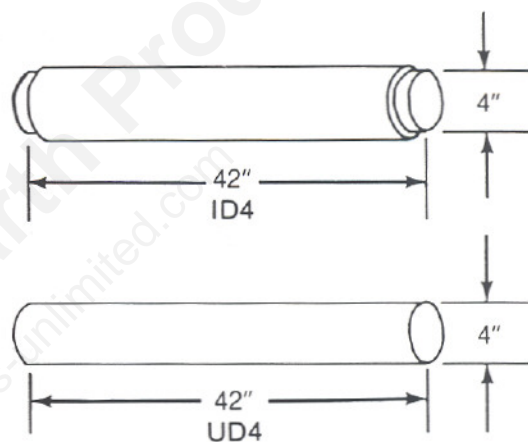

TRANSITION SECTION

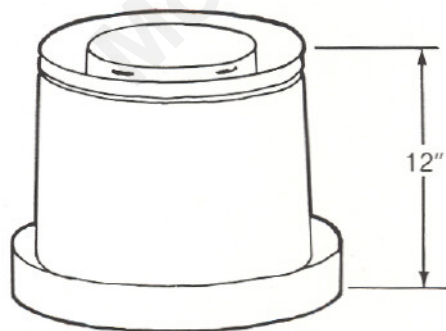

AC542
SL542

CHIMNEY SECTIONS

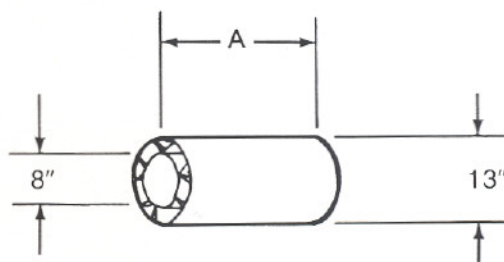

CAT. NO.	A
AC506 SL506	6"
AC512 SL512	12"
AC518 SL518	18"
AC536 SL536	36"
AC548 SL548	48"

CHIMNEY STABILIZER

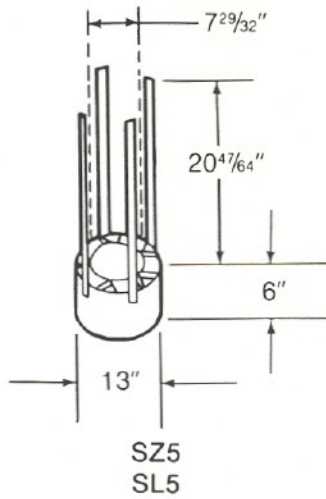

OFFSET/RETURN

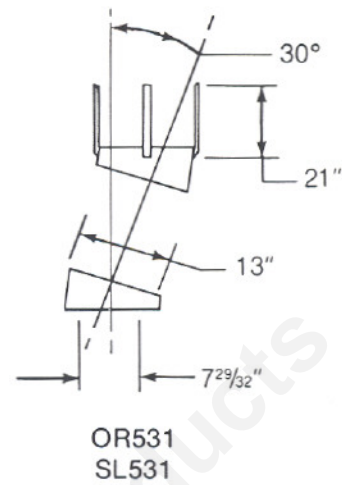

FIRESTOP SPACERS

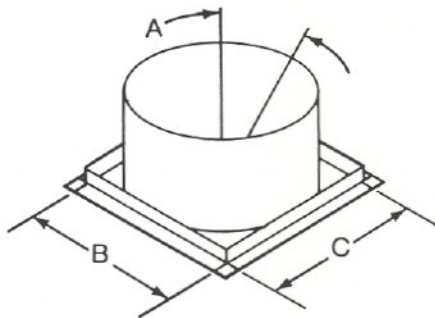

JOINT BAND

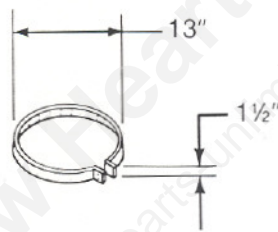

JB577

CHIMNEY BRACKET

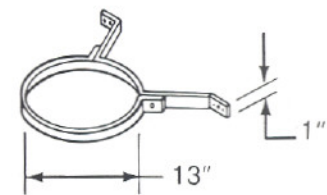

CB576

CAT. NO.	A	B	C
FS544	0°	17"	17"
FS546	30°	26"	17"

ROOF FLASHINGS

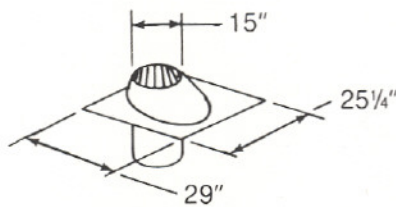

Flat to 6/12 Pitch
RF580

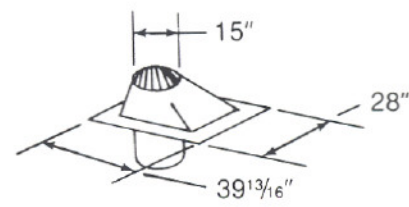

6/12 to 12/12 Pitch
RF581

CHIMNEY TERMINAL CAPS & TERMINATIONS

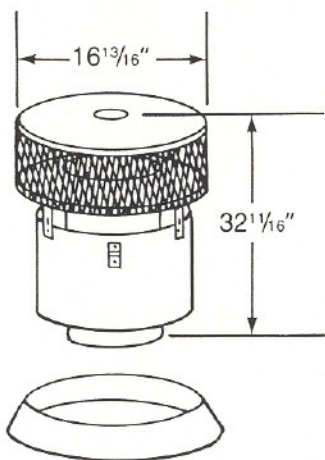

RT582
ROUND TERMINAL CAP

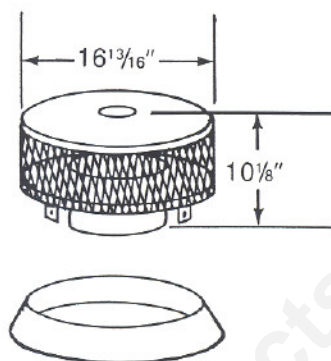

RT584
ROUND TERMINAL CAP

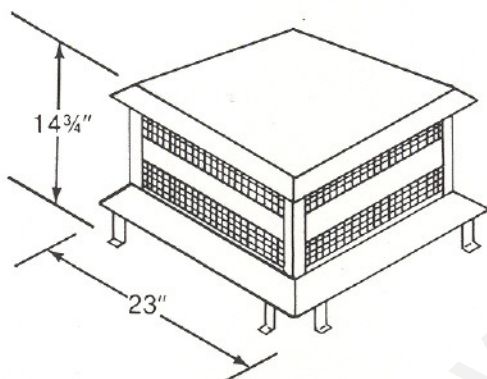

ST575
SQUARE TERMINAL CAP

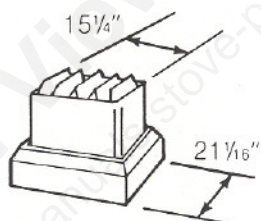

ST8
HOUSING TOP

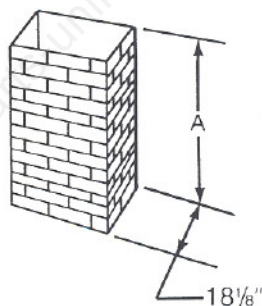

SIMULATED BRICK TERMINATIONS

CAT. NO.	A
RB4	45 3/4"
TB4	45 3/4"
RB6	69 3/4"
TB6	69 3/4"

CHASE TOP

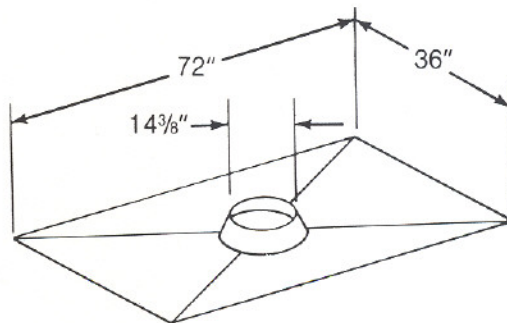

CT56

III. FIREPLACE LOCATIONS, SPACE AND CONSTRUCTION REQUIREMENTS

The fireplace may be located as shown in Figure 1.

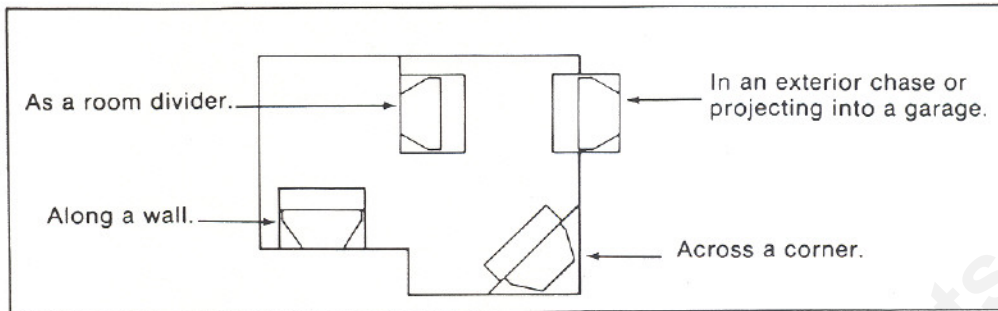

Figure 1
Fireplace Locations

Figures 2 and 3 show installations assuming outside air ducts with allowance for making 90° bends. Less space is required when ducting goes directly outside without forming elbows.

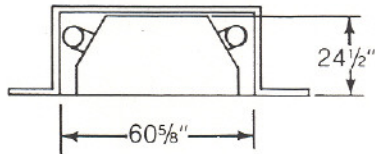

Figure 2
Installation along a wall or an exterior chase.

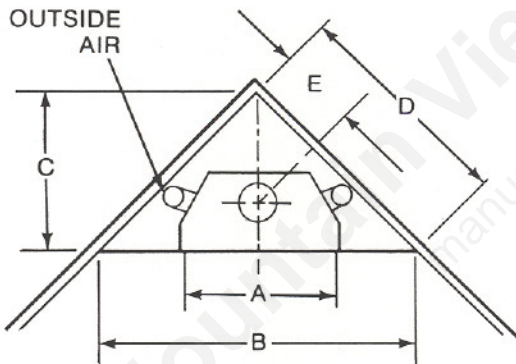

Figure 3
Corner Installation

WITH OUTSIDE AIR

CAT. NO.	A	B	C	D	E
HF42A	48 1/2"	74 7/8"	37 1/2"	53"	17"

WITHOUT OUTSIDE AIR

CAT. NO.	A	B	C	D	E
HF42A	48 1/2"	73 3/8"	36 3/8"	52 1/8"	16 1/2"

ALL DIMENSIONS IN INCHES

WARNING

WHEN LOCATING THE FIREPLACE IN A SPACE PROJECTING INTO A GARAGE, THE OUTSIDE AIR MUST NOT BE TAKEN FROM THE GARAGE SPACE. EXHAUST PRODUCTS OF GASOLINE ENGINES ARE HAZARDOUS.

DO NOT INSTALL OUTSIDE AIR DUCTS SUCH THAT THE AIR MAY BE DRAWN FROM ATTIC SPACES, BASEMENTS, OR ABOVE THE ROOFING WHERE OTHER HEATING APPLIANCES OR FANS AND CHIMNEYS EXHAUST OR UTILIZE AIR. THESE PRECAUTIONS WILL REDUCE THE POSSIBILITY FOR SMOKING OR FLOW REVERSAL.

Figure 4 shows a typical framing of the fireplace, assuming combustible materials are used. All required clearances to combustibles around the fireplace must be adhered to. Any enclosure on top of the fireplace must be above the top standoffs. Chimney Sections at any level require a minimum air space of two inches to the enclosure, including any framing, for the total chimney height.

WARNING

TO PREVENT CONTACT WITH SAGGING OR LOOSE INSULATION, THE FIREPLACE MUST NOT BE INSTALLED AGAINST VAPOR BARRIERS OR EXPOSED INSULATION. LOCALIZED OVERHEATING COULD OCCUR AND A FIRE COULD RESULT.

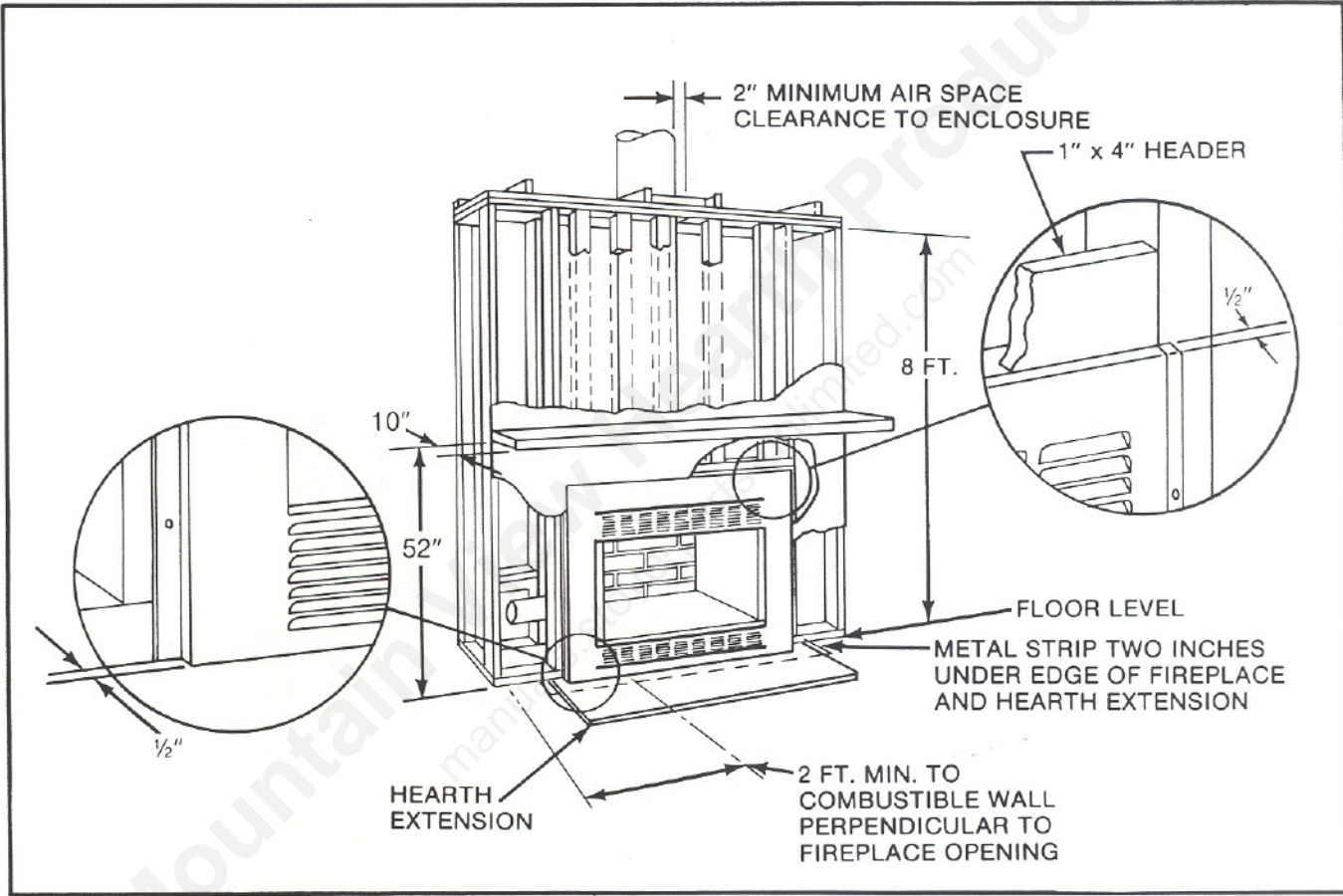

Figure 4
Framing the Fireplace

After completing the framing and after applying the facing material over the framing, a non-combustible sealant, one-half inch wide maximum, must be used to close off any gaps at the top and sides between the fireplace and facing, to prevent cold air leaks. A mantel of combustible material may be installed no less than 52 inches above the platform or floor upon which the fireplace is located. The mantel may extend no more than 10 inches from the wall.

Non-combustible materials may be used to cover the black non-louvered fireplace front, but must not restrict the air flow to or from the front of the unit in any manner. The following is a description of materials specified in these Instructions:

Combustible Material. Material made of or surfaced with wood, compressed paper, plant fibers, plastics, or other material that will ignite and burn, whether flameproofed or not, or whether plastered or unplastered.

Non-combustible Material. Material which will not ignite and burn, such materials consisting entirely of steel, iron, brick, tile, concrete, slate, asbestos, glass or plasters, or combination thereof.

Non-combustible Sealant Material. General Electric RTV103 (Black), or equivalent. Rutland, Inc. Fireplace Mortar #63, or equivalent.

WARNING

DO NOT APPLY FINISH MATERIALS OVER THE LOUVERED FACE OF THESE FIREPLACES. THIS WILL BLOCK THE FLOW OF COOLING AIR AND MAY CAUSE DANGEROUSLY HIGH TEMPERATURES ON COMBUSTIBLE SURFACES OR ON THE FIREPLACE ITSELF.

The use of factory-built Hearth Extensions is shown in Figure 5. These may be covered with a non-combustible decorative material with a maximum thickness of 1/4 inch. Seal gaps with non-combustible (sand-cement) grout.

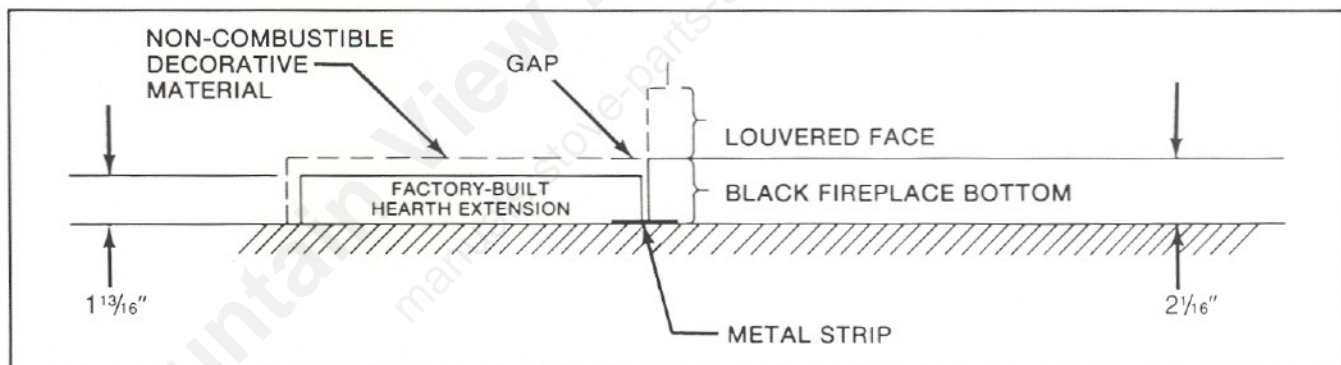

Figure 5
Factory-Built Hearth Extension

Field constructed Hearth Extensions may be used, but must be constructed in accordance with the following instructions. A typical construction is shown in Figure 6. In all cases of field construction, a minimum dimension of 20" to the front and extending 8" on either side of the fireplace opening must be used, and gaps must be sealed with non-combustible (sand-cement) grout.

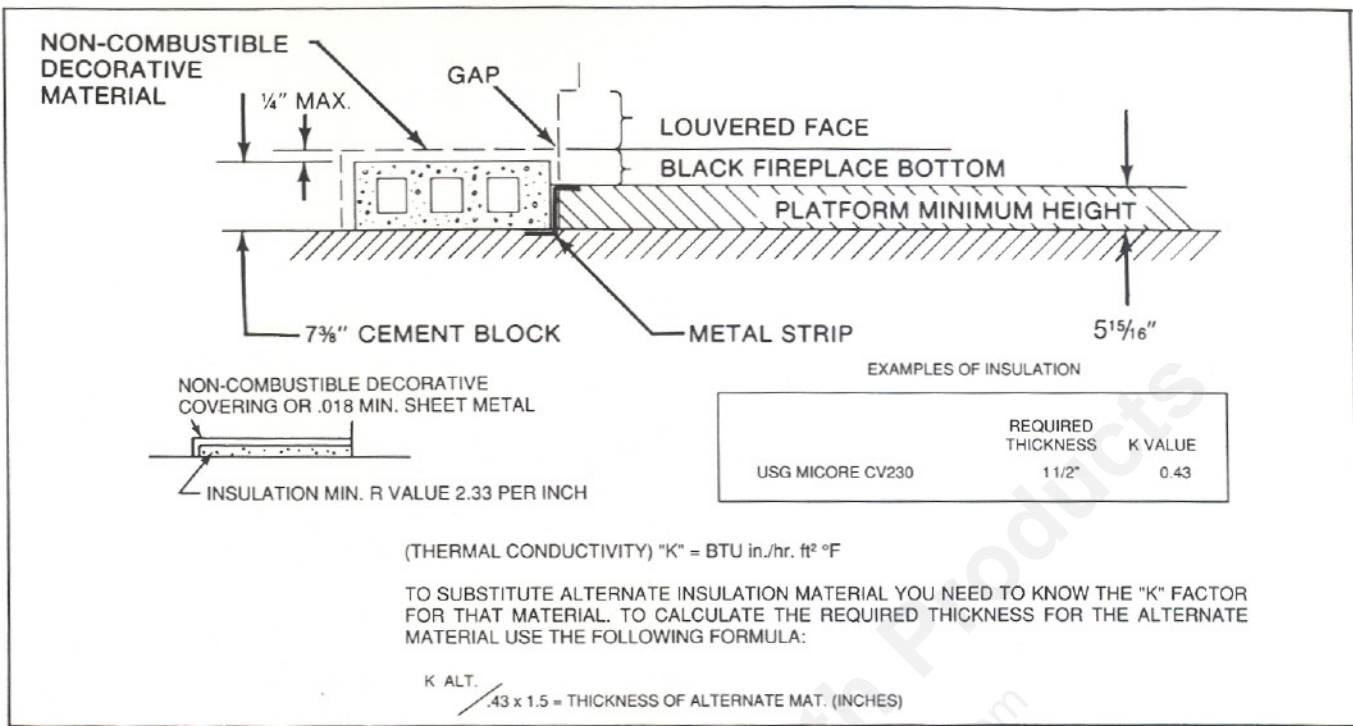

Figure 6
Field Constructed Hearth Extension

A second alternative to the cement block construction shown in Figure 6 is as follows:

1. One course common brick on edge - top layer.
2. 3/8" minimum millboard - middle.
3. Standard combustible construction - base.

Both Figure 6, and the above construction, require that the fireplace be raised on a platform. A metal strip must be used between the fireplace and the field constructed Hearth Extension. Depending on the construction, a special (└) shape may be needed. Each horizontal leg must be 2" wide and the length must be at least equal to the length of the Metal Strip provided with each fireplace. The fireplace must rest on a continuous, level surface.

WARNING

HEARTH EXTENSIONS ARE TO BE INSTALLED ONLY AS ILLUSTRATED TO PREVENT HIGH TEMPERATURES FROM OCCURRING ON CONCEALED COMBUSTIBLE MATERIALS. METAL STRIPS PREVENT BURNING OR HOT PARTICLES FROM INADVERTENTLY FALLING DIRECTLY ON COMBUSTIBLE SURFACES IN THE EVENT THE BUILDING SHOULD SETTLE AND DISTURB THE ORIGINAL CONSTRUCTION.

When planning your fireplace location, the chimney construction and necessary clearance must be considered. Figure 7 illustrates a typical one floor with attic space installation in which joists and rafters may require modification. The fireplace system and chimney components have been tested to provide the following flexibility in construction.

Minimum straight height	14 ft.
Minimum height with Offset/Return	17 ft.
Maximum height	90 ft.
Maximum chimney length between an Offset/Return	8 ft.
Maximum distance between Chimney Stabilizers	35 ft.
Double Offset/Return minimum height	24 ft.
Maximum unsupported chimney length between Offset/Return	6 ft.
Maximum straight unsupported chimney height above firebox	25 ft.

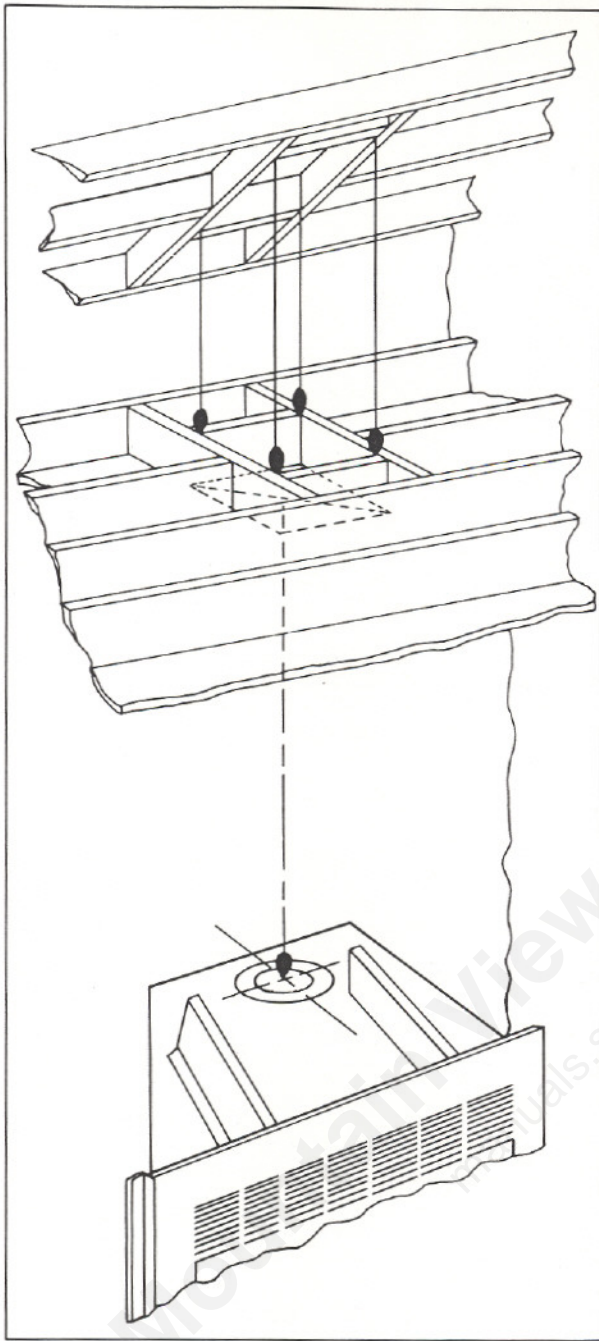

Figure 7
Ceiling and Attic Construction

Joint Bands must be used at every joint between an Offset and Return.

If Outside Combustion Air is used, Figure 8 illustrates only two of many possible locations - a basement fireplace with a maximum vertical height, and a direct exit from the fireplace side.

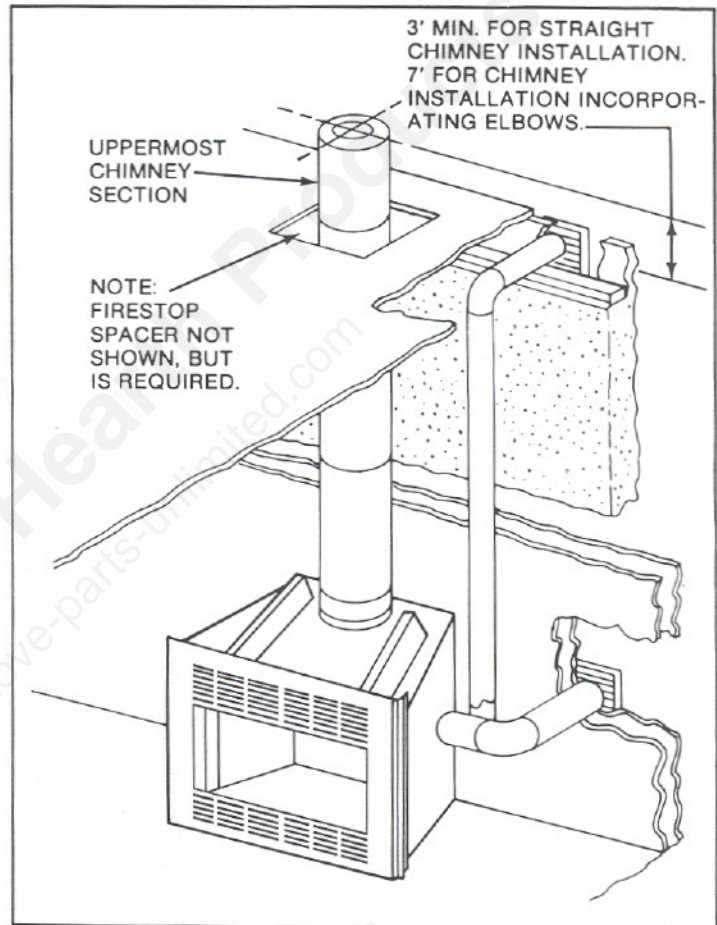

Figure 8
Outside Air Locations

NOTE: A 3' minimum height in a straight chimney installation (and 7' in an Elbow installation) must be maintained from the top of the uppermost Chimney Section to the Outside Combustion Air inlet.

Major building codes specify a minimum chimney height above the roof top. These specifications are summarized in what is known as the "Ten Foot Rule". This rule states:

1. If the horizontal distance from the side of the chimney to the peak of the roof is 10 feet or less, the top of the chimney must be at least 2 feet above the peak of the roof, but never less than 3 feet in height above the highest point where it passes through the roof. See Figure 9.

- If the horizontal distance from the side of the chimney to the peak of the roof is more than 10 feet, a chimney height reference point is established on the surface of the roof a distance of 10 feet from the side of the chimney in a horizontal plane. The top of the chimney must be at least 2 feet above this reference point, but never less than 3 feet in height above the highest point where it passes through the roof. See Figure 10.

These chimney heights are necessary in the interest of safety and do not assure smoke-free operation. Trees, buildings, adjoining roof lines, adverse wind conditions, etc., may require a taller chimney should smoking occur.

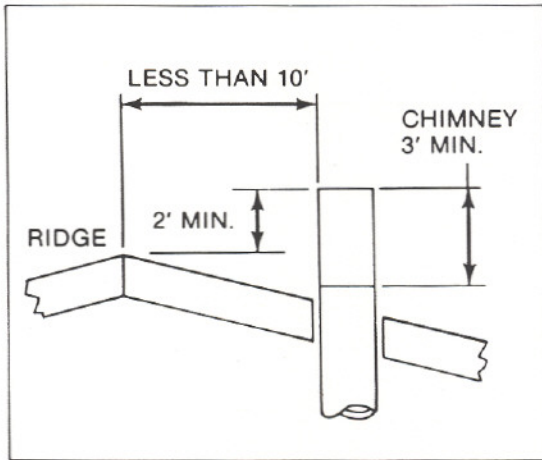

Figure 9
Chimney Height

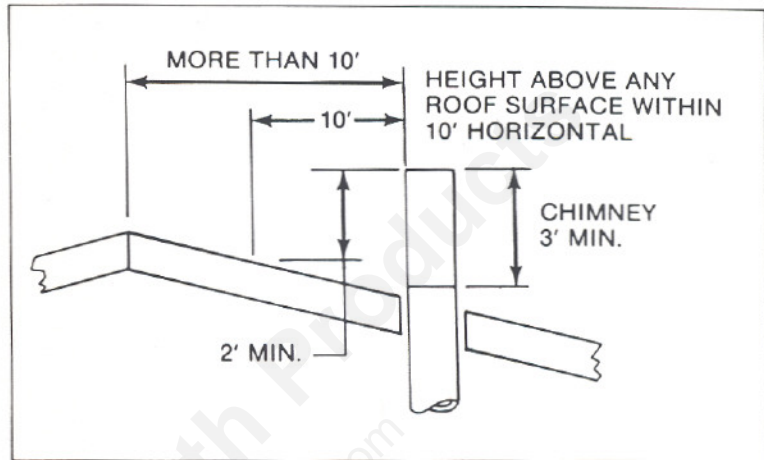

Figure 10
Chimney Height

SELECTING THE CHIMNEY COMPONENTS

Figure 11 illustrates the height from the bottom of the fireplace to the top of the Transition Section. Proper assembly of Air Cooled Chimney Sections results in an overlap at chimney joints of 1 1/4".

Figure 12 and Table 1 enable selection of the appropriate chimney components when using Offsets and Returns.

- Determine amount of offset required to extend the chimney through a wall or around an obstacle. See Figure 12, dimension "A".

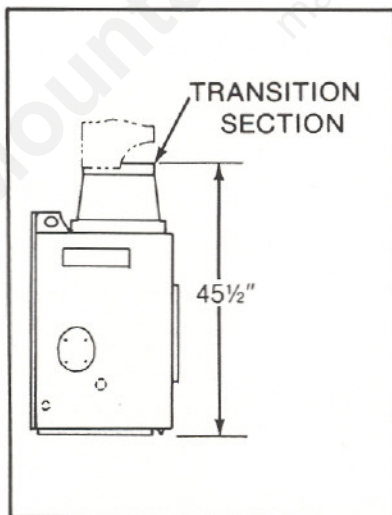

Figure 11
Fireplace (Side View)

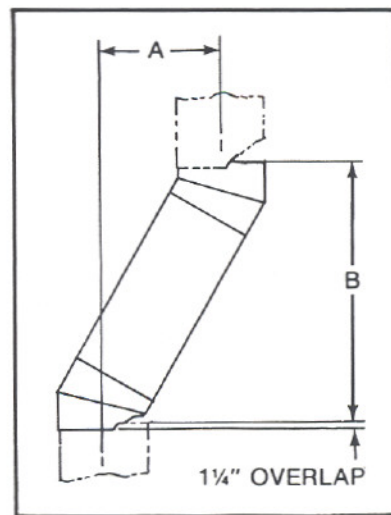

Figure 12
Chimney Offset/Return

2. Refer to the following 30° offset chart and find the "A" dimension closest to but not less than the amount of offset required in your installation.

WARNING

DO NOT COMBINE OFFSETS TO CREATE AN OFFSET GREATER THAN 30° FROM VERTICAL. THIS MAY CREATE A FIRE HAZARD SINCE THE NATURAL DRAFT MAY BE RESTRICTED.

3. Find the "B" dimension on the chart and determine if it is compatible with your installation.
4. Read across the chart and find the Catalog Number and number of Chimney Sections required. If using AC series - twist lock - the last column indicates the number of Joint Bands needed. SL series - snap lock - does not require the use of Joint Bands between an Offset and Return.
5. Refer to the Step-By-Step Installation Instructions following the chart.
6. All joist areas must be Firestopped.

TABLE 1
30° Offset Chart (Dimensions in Inches)

A	B	AC506 SL506	AC512 SL512	AC518 SL518	AC536 SL536	AC548 SL548	JB577*
3 $\frac{7}{8}$	14 $\frac{7}{16}$	—	—	—	—	—	1
6 $\frac{1}{4}$	18 $\frac{9}{16}$	1	—	—	—	—	2
9 $\frac{1}{4}$	23 $\frac{3}{4}$	—	1	—	—	—	2
12 $\frac{1}{4}$	28 $\frac{15}{16}$	—	—	1	—	—	2
14 $\frac{5}{8}$	33 $\frac{1}{16}$	—	2	—	—	—	3
17 $\frac{5}{8}$	38 $\frac{3}{4}$	—	1	1	—	—	3
21 $\frac{1}{4}$	44 $\frac{9}{16}$	—	—	—	1	—	2
23 $\frac{5}{8}$	48 $\frac{11}{16}$	1	—	—	1	—	3
27 $\frac{1}{4}$	55 $\frac{3}{4}$	—	—	—	—	1	2
29 $\frac{5}{8}$	59 $\frac{1}{16}$	1	—	—	—	1	3
32 $\frac{5}{8}$	64 $\frac{1}{4}$	—	1	—	—	1	3
35 $\frac{5}{8}$	69 $\frac{1}{16}$	—	—	1	—	1	3
38	73 $\frac{9}{16}$	—	2	—	—	1	4
41	78 $\frac{3}{4}$	—	1	1	—	1	4
44 $\frac{5}{8}$	85 $\frac{1}{16}$	—	—	—	1	1	3
47	89 $\frac{5}{8}$	1	—	—	1	1	4
50 $\frac{5}{8}$	95 $\frac{7}{16}$	—	—	—	—	2	3

*NOTE: Joint Bands, JB577, are not required for use with SL series - snap lock. AC series - twist lock - must use a Joint Band over each Chimney Section Joint between an Offset and Return.

IV. STEP-BY-STEP INSTALLATION OF THE FIREPLACE SYSTEM

WARNING

BEFORE STARTING, DO THE FOLLOWING:

1. WEAR GLOVES AND SAFETY GLASSES FOR PROTECTION.
2. KEEP HAND TOOLS IN GOOD CONDITION. SHARPEN CUTTING EDGES AND MAKE SURE TOOL HANDLES ARE SECURE.
3. ALWAYS MAINTAIN THE MINIMUM AIR SPACE REQUIRED TO THE ENCLOSURE TO PREVENT FIRE.

STEP 1

Position the fireplace and nail wood blocks along the sides to prevent the fireplace from shifting (blocks must be removed later).

STEP 2

Slide the metal strip two inches under the front edge of the fireplace. See Figure 4. When the metal strip is not provided as a single piece, then the individual pieces must overlap each other approximately one inch.

STEP 3

Level the fireplace side-to-side and front-to-back. Shim with non-combustible material as necessary. Secure the fireplace by utilizing the nailing flanges located on either side of the fireplace.

STEP 4

Two styles of Air Cooled Chimney are available for use with this fireplace, AC series - twist lock, or SL series - snap lock. Choose one of these and locate the appropriate Transition Section (AC542 or SL542) on the top of the fireplace and secure it using (4) #10x1/2 screws provided in the fastener package. As your installation requires, assemble either a straight Pipe Section or an Offset to the Transition Section. NOTE: When using AC series - twist lock, always secure all Offsets and Pipe Sections with the screws provided.

WARNING

FOLLOW THE INSTRUCTIONS FOR ASSEMBLY OF THE PIPE AND OTHER PARTS, WHICH ARE PACKED WITH EVERY PIPE SECTION AND ALL OTHER COMPONENTS NEEDED TO INSTALL THIS FIREPLACE SYSTEM. FAILURE TO DO SO MAY RESULT IN A FIRE, ESPECIALLY IF COMBUSTIBLES ARE TOO CLOSE TO THE FIREPLACE OR CHIMNEY AND AIR SPACES ARE BLOCKED PREVENTING THE FREE MOVEMENT OF COOLING AIR.

STEP 5

Mark and cut out an opening in the ceiling for the particular Firestop Spacer being utilized. Frame the opening with the same size lumber used in the ceiling joists. See Chapter 25 of the Uniform Building Code for general construction requirements when "Framing Around Openings".

STEP 6

Install the Firestop Spacer FS544 (Straight), or FS546 (30° Offset, if Offset is located in the ceiling joist area). These Firestop Spacers are designed to provide the minimum two inch air space around the chimney. In all situations, the Firestops are to be nailed to the ceiling joists from the bottom or fireplace side, EXCEPT, when the space above the ceiling is an attic space. In this situation, the Firestop must be nailed from the attic side to ensure against loose or later blow-in-type insulation from falling into the required two inch air space around the chimney. Firestop Spacers must be used at all ceiling levels where the chimney penetrates a living space.

□ STEP 7

Continue assembling Chimney Sections up through the Firestop Spacers as needed. Check height and unsupported chimney length limitations described earlier.

The maximum straight unsupported height is 25 feet above the firebox and 35 feet between Chimney Stabilizers.

□ STEP 8

When Offsets/Returns are joined to straight Pipe Sections, they must be locked in position with the size 10 sheet metal screws provided, using the predrilled holes. Offsets/Returns and Chimney Stabilizers have straps for securing these parts to joists or rafters. Plumbers tape may be purchased locally and used in conjunction with Joint Bands to secure the chimney as an alternate method. Chimney Brackets may be used to stabilize the chimney. See Figures 13 and 14.

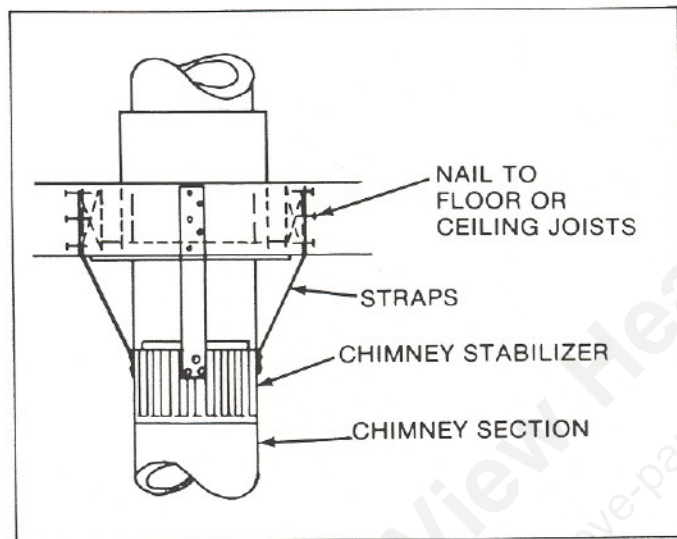

Figure 13
Chimney with Stabilizer

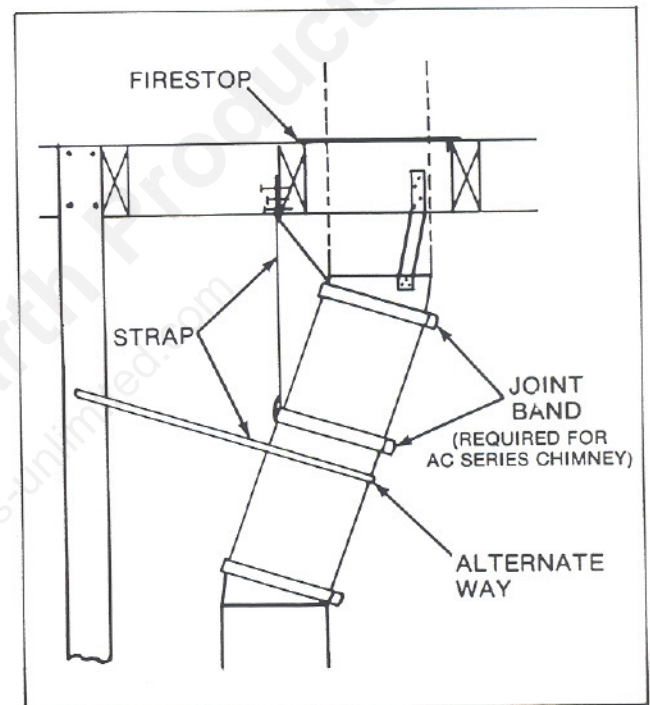

Figure 14
Offset/Return Installation

WARNING

WHEN CHIMNEY SECTIONS EXCEEDING 6 FEET IN LENGTH ARE INSTALLED BETWEEN AN OFFSET/RETURN, STRUCTURAL SUPPORT MUST BE PROVIDED TO REDUCE OFF-CENTER LOADING AND PREVENT CHIMNEY SECTIONS FROM SEPARATING AT THE CHIMNEY JOINTS.

□ STEP 9

Locate the point where the chimney will exit the roof by plumbing down to the center of the chimney. Drive a nail through the roof to mark the center.

STEP 10

Measure to either side of the nail and mark the 17" x 17" opening required. This 17" x 17" is measured on the horizontal; actual length may be larger depending on the pitch of the roof. Cut out and frame the opening. See Chapter 25 of the Uniform Building Code for Roof Framing details.

STEP 11

Continue to add Chimney Sections through the roof opening, maintaining at least a 2" air space.

STEP 12

Install the Roof Flashing appropriate to the roof pitch. Assemble the Storm Collar to protect against rain entering around the outside of the chimney, and add the Chimney Terminal Cap. The Terminal Cap must be one of the following: RT582 (Telescoping-Round), RT584 (Round), ST575 (Square), or ST8 (Housing Top) with RB4, TB4, RB6 or TB6 Simulated Brick Panels.

WARNING

DETAIL INSTRUCTIONS FOR INSTALLATION OF THE ROOF FLASHING, STORM COLLAR AND TERMINAL CAP ARE FOUND PACKAGED WITH THESE PARTS. TO AVOID DANGER OF FIRE, ALL INSTRUCTIONS MUST BE STRICTLY FOLLOWED, INCLUDING THE PROVISION OF AIR SPACE CLEARANCE BETWEEN CHIMNEY SYSTEM AND COMBUSTIBLE ENCLOSURE. TO PROTECT AGAINST EFFECTS OF METAL CORROSION OF THE ABOVE PARTS, FIRST WASH THEM WITH A SOLVENT OR VINEGAR, RINSE WITH WATER, AND THEN PAINT WITH A RUST RESISTANT PAINT.

STEP 13

Frame the fireplace enclosure, allowing space for outside air ducts and gas piping if desired. Care must be taken with any electrical wiring to avoid exposure to high temperatures or mechanical damage to wire insulation. A minimum clearance of 1/2" must be maintained between the fireplace sides and back and the combustible enclosure. Check to be sure blocks from STEP 1 have been removed.

STEP 14

Knockouts are provided on both sides of the fireplace to allow for connection of a decorative gas appliance, in accordance with the National Fuel Code, ANSI Z223.1-1980. The side refractories are designed to allow 1/2" iron pipe to pass through. Use a non-combustible sealant to seal any opening between the gas pipe and refractory on the inside. Repack the insulation removed, to seal around the gas pipe where it exits the side of the fireplace.

CAUTION

- 1. WHEN USING THE DECORATIVE APPLIANCE, THE FIREPLACE DAMPER MUST BE SET IN THE FULLY OPEN POSITION.**
- 2. A FULLY OPEN DAMPER ENSURES PROPER VENTING OF COMBUSTION PRODUCTS.**

STEP 15

Install Outside Air if desired or required by local code, using the Instructions supplied with the AK42-A Air Kit.

STEP 16

Install Fans if desired, using the Instructions supplied with the FK25A Fan Kit.

NOTE: Whether intending to install the Fan now, or anticipating installation in the future, it is recommended that you pre-wire the fireplace at the junction box during the installation of the fireplace. Remove the junction box cover located on the left side of the fireplace by removing the two screws used to secure it. Remove the 13/16" diameter knockout by the side of the junction box opening and insert the electrical conduit attached to a 1/2" EMT conduit connector (pressure cast set screw type) through this hole and secure the conduit to the outer shell with the conduit connector lock nut. Firmly attach the supply wires to the appropriately colored receptacle lead wires in the junction box using a 105° C class wire nut that will accept (2) 18 ga. wires. Replace the junction box cover and secure it with the screws previously removed. See Figure 15.

WARNING

DISCONNECT POWER BEFORE STRIPPING OR JOINING ANY SUPPLY WIRES. ONLY PERSONS QUALIFIED FOR MAKING ELECTRICAL INSTALLATIONS (ELECTRICIANS) AS RECOGNIZED BY LOCAL OR NATIONAL GOVERNMENTAL BODIES SHOULD ATTEMPT TO MAKE THE INCOMING SUPPLY WIRE CONNECTIONS.

EDGES ARE SHARP. HAND PROTECTION IS RECOMMENDED. RECHECK ALL FASTENERS BEFORE LEAVING JOB.

NOTE: A Motor Speed Control Kit, Catalog Number BC10, is available for use with this Fan Kit. Refer to the Instructions packed with it for proper installation. If a speed control option is desired, it is recommended to use the BC10 Kit to insure proper function.

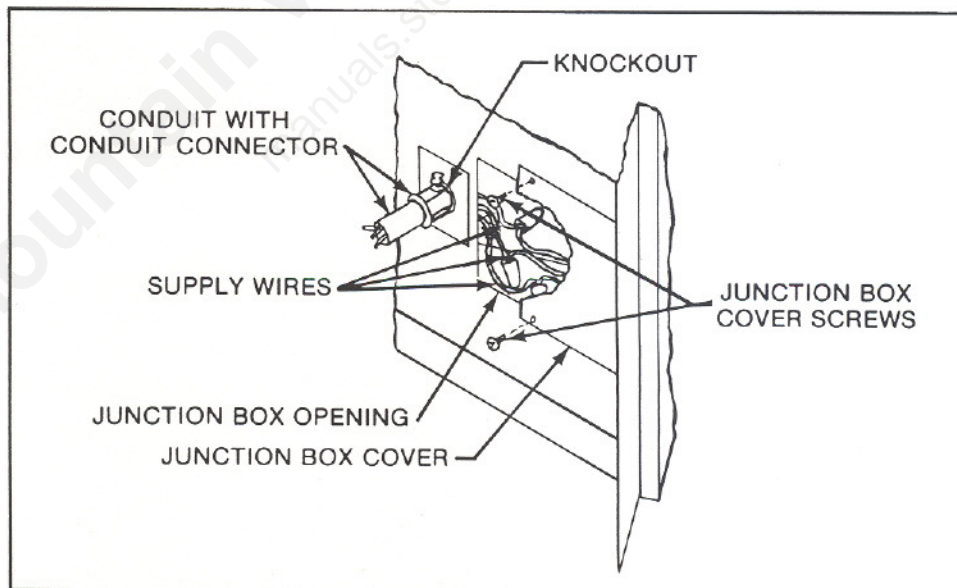

Figure 15
Junction Box Wiring

STEP 17

Install Glass Doors if desired, using the Instructions supplied with these optional accessories. Protect Glass Doors from breakage by temporarily removing them until all construction is complete.

STEP 18

Position the Hearth Extension over the metal protective strip which should project about two inches in front of the fireplace bottom front. See Figure 4. Seal the crack between the Hearth Extension and fireplace with a non-combustible (sand-cement) grout.

STEP 19

Apply the finish materials of your choice. Do not install combustible materials over the black face of the fireplace or louvered openings. You may use non-combustible material over the black - non-louvered - face of the fireplace.

STEP 20

This fireplace is equipped with a factory installed Integral Grate. In the event it becomes necessary to replace it, loosen the refractory retainers at the top of the side refractories, and remove the cover strips at the front of the side refractories. Slide the side refractories forward until the Grate can be removed. To install the new Grate, slide the Grate into the hubs located in each side of the firebox, then push the side refractories back against the back refractory. Reposition the refractory retainers and reinstall the cover strips to secure the side refractories in position. Use only Catalog Number GR42-2 Integral Grate for replacement.

STEP 21

Prior to building your first fire in your fireplace, please read the "Operating Instructions" section that follows.

WARNING

DO NOT PACK REQUIRED AIR SPACES WITH INSULATION OR OTHER MATERIALS. THIS PREVENTS THE NATURAL CONVECTION COOLING WHICH MUST TAKE PLACE. THE REQUIRED CLEARANCES ARE TO THE ENCLOSURE AND SHOULD NOT BE REDUCED BY THE ADDITION OF OTHER MATERIALS WHETHER OF NON-COMBUSTIBLE OR COMBUSTIBLE MATERIAL. COMBUSTIBLE MATERIALS AS WELL AS THE NON-COMBUSTIBLE MATERIALS USED IN THE FIREPLACE MAY HAVE THEIR USEFUL LIFE REDUCED.

V. CONSTRUCTING A CHASE

The chase may be constructed for the fireplace and chimney or for the chimney only. A chase is an enclosure built around the system. It is most commonly constructed on an outside wall as shown below.

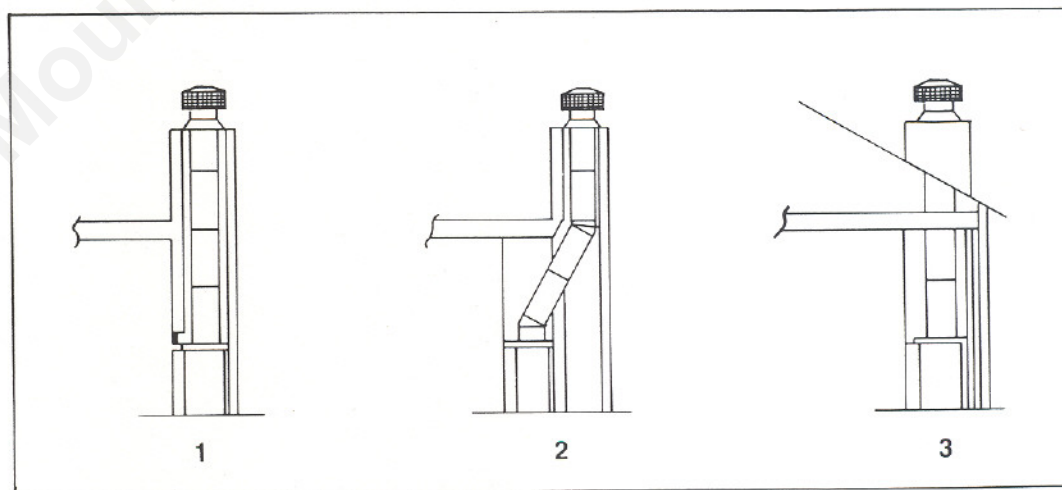

Figure 16
Chase Constructions

Three examples of chase applications are shown in Figure 16.

1. Fireplace and chimney enclosed in chase - exterior.
2. Chimney offset through exterior wall and enclosed in chase.
3. Chase constructed on roof.

MATERIALS FOR CHASE

The chase is constructed much the same as the walls in your home. A variety of materials may be used including brick, stone, veneer brick, or standard siding materials.

In constructing the chase, several factors must be considered.

1. Maintain a 2" air space clearance around the chimney.
2. The Chase Top must be constructed of a non-combustible material.
3. The walls of the chase must be insulated to prevent heat leaking from the home around and through the fireplace.

TO INSTALL TERMINAL CAP ON CHASE - ENCLOSED CHIMNEY

1. Construct chase of desired materials maintaining a minimum 2" air space around the chimney.

WARNING

NEVER INSTALL A SINGLE WALL SLIP SECTION OR SMOKE-PIPE IN A CHASE STRUCTURE. THE HIGHER TEMPERATURE OF THIS SINGLE WALL PIPE MAY RADIATE SUFFICIENT HEAT TO COMBUSTIBLE CHASE CONSTRUCTION MATERIALS TO CAUSE A FIRE.

2. Install the Chimney Sections up through the chase. When using a Round Terminal Cap (RT584), the last section of Pipe must extend at least six inches above the Chase Top to allow installation of the Storm Collar and Terminal Cap. For installations utilizing a Telescoping Round Terminal Cap (RT582), the last Chimney Section must not be more than 15" below or 3" above the Chase Top. If a Square Terminal Cap (ST575) is utilized, see separate Installation Instructions.

WARNING

DETAIL INSTRUCTIONS FOR INSTALLATION OF THE CHASE TOP, STORM COLLAR AND TERMINAL CAP ARE FOUND PACKAGED WITH THESE PARTS. TO AVOID DANGER OF FIRE, ALL INSTRUCTIONS MUST BE STRICTLY FOLLOWED, INCLUDING THE PROVISION OF AIR SPACE CLEARANCE BETWEEN CHIMNEY SYSTEM AND COMBUSTIBLE ENCLOSURE AND BETWEEN CHASE AND CHASE TOP. TO PROTECT AGAINST EFFECTS OF METAL CORROSION OF PARTS SUCH AS CHASE TOP AND THOSE ABOVE CHASE TOP, FIRST WASH THEM WITH A SOLVENT OR VINEGAR, RINSE WITH WATER, AND THEN PAINT WITH A RUST RESISTANT PAINT.

3. Attach the Chase Top to the top of the chase according to the Installation Instructions packaged with the CT56 Chase Top.
4. Loosen the bolt on the Storm Collar and slide it down over the Pipe to the Chase Top. Tighten the bolt and seal around the Collar.
5. Attach and secure either a Round or Square Terminal Cap.

OPERATING INSTRUCTIONS

NOTICE

SAVE AND PASS THESE OPERATING INSTRUCTIONS AND THE INSTALLATION INSTRUCTIONS TO SUBSEQUENT OWNERS. THE INFORMATION PROVIDED IS INTENDED TO NOTIFY AND WARN THEM ABOUT MAKING UNSAFE FUTURE MODIFICATIONS SUCH AS THE ADDITION OF SHELVES OR THE USE OF UNAUTHORIZED PARTS AND REPAIRS.

CAUTION

EDGES ARE SHARP. HAND PROTECTION IS RECOMMENDED.

Before starting a fire in your new or existing fireplace, use the following check list:

- A. **FLUE DAMPER.** When the damper handle is raised out of the closed position, the handle should move toward the full open position. Verify by looking up from the inside of the firebox. Always operate this fireplace with the damper fully open. Please note, downdrafts, obstructions, damage or poor (wet) fuels can cause smoke spillage.

WARNING

DO NOT MODIFY DAMPER PLATE BY PROVIDING INTERMEDIATE NOTCHES NOT SUPPLIED BY THE FACTORY. THIS CAN RESULT IN SEVERE OVERTEMPORATURES AND POSSIBLE FIRE. THE FIREPLACE MUST BE OPERATED WITH THE DAMPER IN THE FULL OPEN POSITION.

- B. **CHIMNEY INSPECTION.** Visually inspect the chimney internally for obstructions and construction damage. Flue pipe joints and seams must be continuous and mechanically tight. In a used chimney, additional inspection is needed for the following:

“Creosote - Formation and Need for Removal.

When wood is burned slowly, it produces tar and other organic vapors, which combine with expelled moisture to form creosote. The creosote vapors condense in the relatively cool chimney flue of a slow-burning fire. As a result, creosote residue accumulates on the flue lining. When ignited, this creosote makes an extremely hot fire.

The chimney should be inspected at least twice monthly during the heating season to determine if creosote build-up has occurred.

If creosote has accumulated, it should be removed to reduce the risk of a chimney fire.”

C. CHIMNEY CLEANING. If you do detect a build-up of creosote, contact a qualified chimney sweep or clean it yourself.

1. Open the damper.
 2. Hang a damp sheet across the fireplace opening to stop dirt and soot from entering the room.
 3. Remove the Terminal Cap or Housing Top. See Figure 1.
 4. Clean with a stiff bristled brush attached to a pole.
- OR
- 4A. Tie a rope to a burlap bag filled with straw and several stones. Work up and down the flue until clean.
 5. Replace the Terminal Cap or Housing Top.

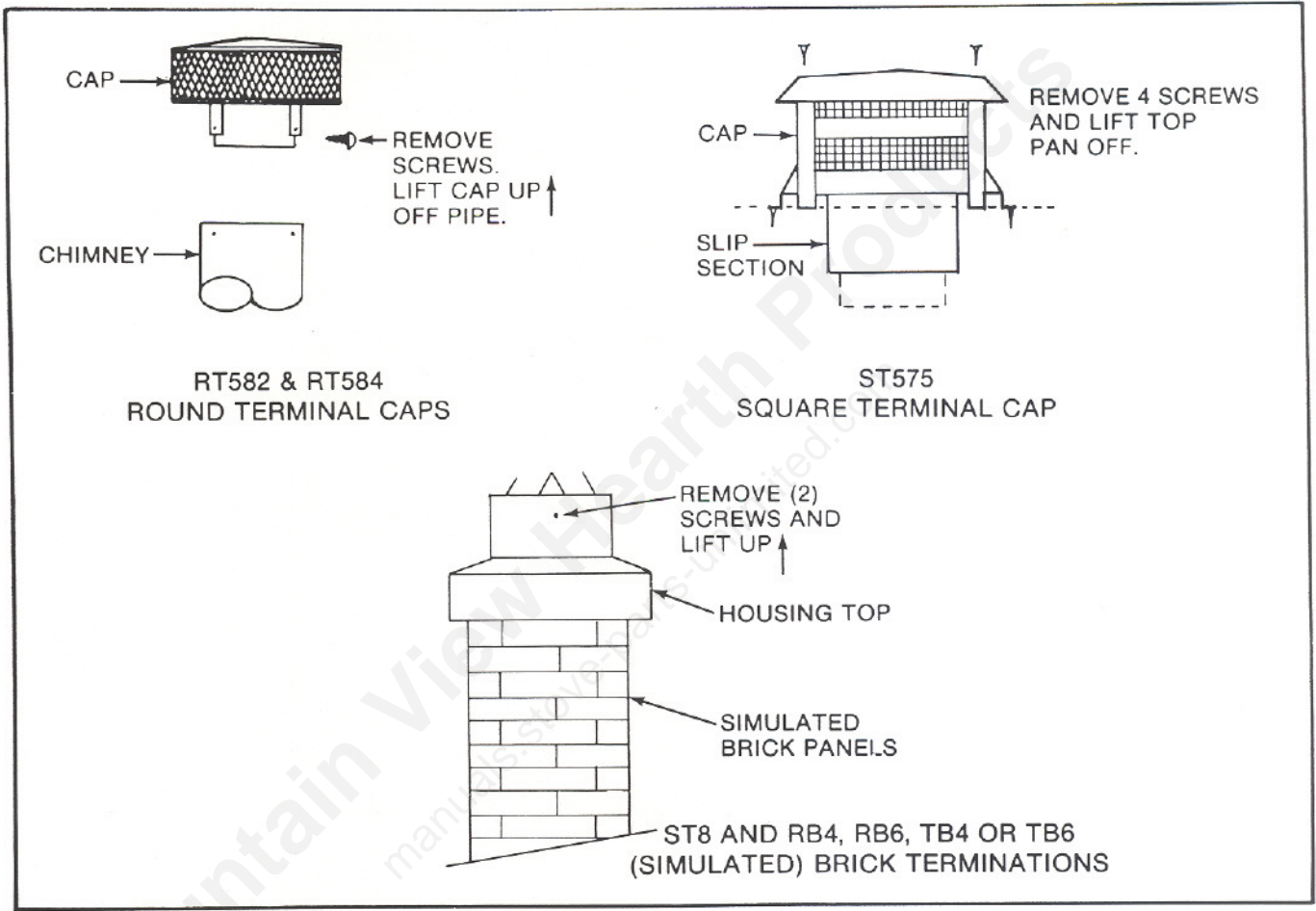

Figure 1
Terminal Caps

D. CLEAR SPACE NEAR FIREPLACE. The Hearth Extension must extend at least 20 inches to the front and 8 inches on either side of the firebox opening. Combustible materials must not be stored in this area. Combustible walls perpendicular to the front of the fireplace must be at least 2 feet from the fireplace opening. Room furnishings such as drapes, curtains, chairs, or other combustibles must be at least 4 feet from the open front of the fireplace. Louvered openings on the face of this fireplace are provided for circulation of cooling air, and must not be blocked.

E. GRATE. The factory installed Integral Grate must be used to hold the logs from falling out of an open fireplace and to allow air to pass between the burning logs. It is important to keep the fire off the hearth and to allow the ashes to collect beneath the fire, thereby forming a layer of additional heat protection. See Figure 2. Use only Catalog Number GR42-2 Integral Grate for replacement.

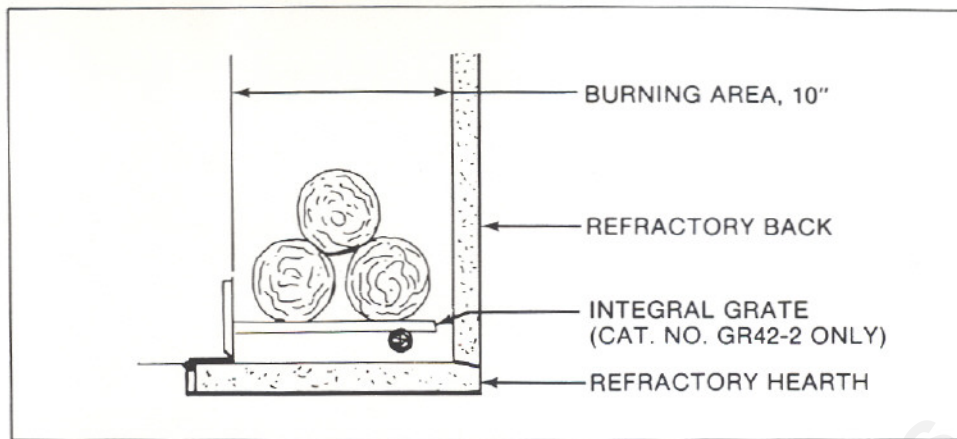

Figure 2
Section Through Fireplace

- F. **FIRESCREEN.** A firescreen is always provided to control sparks. It must be closed whenever the fireplace is in use. Glass Doors or firescreens must not be used to hold burning material inside the fireplace as might occur when overfilling the fireplace with empty boxes or branches. Only those Glass Door units specifically tested and listed for use with the specific fireplace model should be used. Screens should be closed when the Glass Doors are closed.
- G. **OUTSIDE AIR.** A damper allows individual control of the Outside Air inlets if your fireplace is equipped with this option. In a tightly sealed or well insulated home, replacement of combustion air is necessary to keep harmful gases from entering living spaces.

CAUTION

FIREPLACE OPERATION DOES REQUIRE AIR. DO NOT TAKE AIR FROM OTHER FUEL BURNING APPLIANCES WHICH CAN RESULT IN IMPROPER VENTING (SMOKING) OR AIR DILUTION. ALWAYS PROVIDE ADEQUATE MAKE-UP AIR.

- H. **SETTING THE FIRE.** Check the flue damper to be sure it is fully open. Place crumpled or twisted paper under the Grate. Loosely arrange kindling or small pieces of wood to form a layer above the paper. Place three logs in a rough pyramid as shown in Figure 2, being sure to allow free air space between the logs. Small sticks of wood may be used to separate the logs. **NOTE:** When heated the first time, the temperature of the fireplace must be raised gradually, to prevent moisture within the refractory from causing cracks, and to allow the binders in the insulation to dissipate.

CAUTION

NEVER USE GASOLINE, GASOLINE-TYPE LANTERN FUEL, KEROSENE, CHARCOAL LIGHTER FLUID, OR SIMILAR LIQUIDS TO START OR 'FRESHEN UP' A FIRE IN THIS FIREPLACE. KEEP ALL SUCH LIQUIDS WELL AWAY FROM THE FIREPLACE WHILE IT IS IN USE TO AVOID THE RISK OF FIRE.

- I. **DISPOSAL OF ASHES.** Ashes should be placed in a metal container with a tight-fitting lid. The closed container of ashes should be placed on a non-combustible floor or on the ground, well away from all combustible materials, pending final disposal. If the ashes are disposed of by burial in soil or otherwise locally dispersed, they should be retained in the closed container until all cinders have thoroughly cooled.
- J. **GLASS DOORS.** Most efficient fireplace operation using Glass Doors is with the Doors open, as can be felt when standing in front of the fireplace. When not burning the fireplace, Glass Doors will prevent loss of room heat through the chimney. Only HEATILATOR® Glass Doors, Catalog Numbers GF42A, GF42B or GD42, may be used.

WARNING

FIREPLACES EQUIPPED WITH DOORS SHOULD BE OPERATED ONLY WITH DOORS FULLY OPEN OR DOORS FULLY CLOSED. IF DOORS ARE LEFT PARTLY OPEN, GAS AND FLAME MAY BE DRAWN OUT OF THE FIREPLACE OPENING, CREATING RISKS OF BOTH FIRE AND SMOKE.

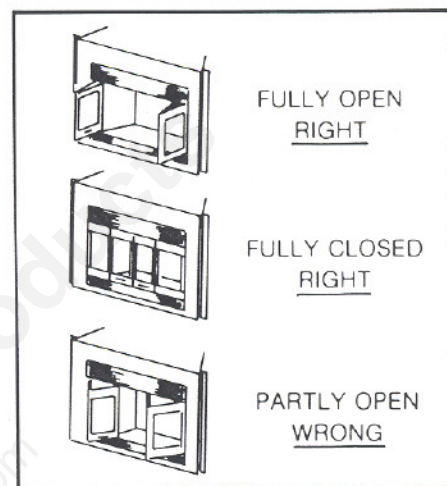

GLASS DOORS

K. OPERATING YOUR FIREPLACE.

WARNING

CONTINUED OVERFIRING CAN PERMANENTLY DAMAGE YOUR FIREPLACE SYSTEM. EXAMPLES OF OVERFIRING ARE:

1. **QUANTITIES OF SCRAP LUMBER, PINE BRANCHES OR CARDBOARD BOXES WHICH EXCEED THE VOLUME OF THE "NORMAL LOG FIRE". THESE MATERIALS PRODUCE MANY SPARKS AND MUST NOT BE USED.**
2. **THE "NORMAL LOG FIRE" IS THREE LOGS, EACH FOUR INCHES IN DIAMETER, WITH THE LENGTH NO GREATER THAN THE BACK WALL OF THE FIREPLACE. THE RATE OF FIRING MUST NOT EXCEED THESE THREE LOGS PER HOUR.**

- L. **FAN KIT.** HEATILATOR® FK25A Heat Circulating Fans may be used with this fireplace. An external ON/OFF switch must be provided, or a Motor Speed Control, BC10, may be used. Use of these dual fans will increase efficiency and heat output.
- M. **SAFETY - A FINAL WORD.** Fireplaces as well as other woodburning appliances have been used safely for many years. Our own experience is that most problems are caused by improper installation, fueling, and operating. All dimensions specified are minimum and increasing distances to combustibles decreases risk. Such common practice as surrounding the fireplace with loose fill insulation, and especially leaving the fire unattended, will increase the risk of fire.



Attention
**Fireplace
Installer:**

*Please return operating
and installation
instructions to the firebox
for consumer use.*

heatilator[®]
THE WOODBURNING SPECIALISTS