

# heatilator®

*The first name in fireplaces*

Heatilator Inc.  
1915 W. Saunders Street  
Mt. Pleasant, IA 52641  
Division, HON. INDUSTRIES

## MODEL LX INSTALLATION & OPERATING INSTRUCTIONS FOR RESIDENTIAL USE

### I. LISTINGS AND CODE APPROVALS

The LX fireplace system has been tested in accordance with Underwriters Laboratories Inc. Standards, and has been LISTED by them for installation and operation as described in these Installation & Operating Instructions.

Fireplace Catalog Number LX has been tested and LISTED for use with the Optional Components described in Section II of these instructions. These Optional Components may be purchased separately and installed at a later date. However, installation of the Outside Air Kit, Junction Box Kit and Fan Kit will require significant reconstruction, and should be installed at the time of initial installation.

Check with your local building code agency before you begin installation to ensure compliance with local codes, including the need for "permits" and follow-up inspections. If any problems are encountered regarding code approvals, or if you wish clarification of any of the instructions contained here, contact: Technical Services, Heatilator Inc., 1915 W. Saunders Street, Mt. Pleasant, Iowa 52641. HEATILATOR® is a registered trademark of Heatilator Inc., Division, HON INDUSTRIES.

#### WARNING

**THIS HEATILATOR FIREPLACE AND ITS COMPONENTS ARE DESIGNED TO BE INSTALLED AND OPERATED AS A SYSTEM. ANY ALTERATION TO OR SUBSTITUTION FOR ITEMS IN THIS SYSTEM UNLESS ALLOWED BY THESE INSTALLATION INSTRUCTIONS WILL VOID THE UNDERWRITERS LABORATORIES LISTING AND MAY VOID THE PRODUCT WARRANTY. IT MAY ALSO CREATE A HAZARDOUS INSTALLATION. READ THROUGH THESE INSTRUCTIONS THOROUGHLY BEFORE STARTING YOUR INSTALLATION AND FOLLOW THEM CAREFULLY THROUGHOUT YOUR PROJECT.**

### II. DESCRIPTION OF THE FIREPLACE SYSTEM

The HEATILATOR® fireplace system consists of the following:

1. Fireplace
2. Hearth Extension
3. Chimney System
4. Roof Termination
5. Integral Grate

Optional components include:

1. Outside Combustion Air System
2. Heat Circulating Fans
3. Solid Brass Trim Kit

## THE FIREPLACE SYSTEM COMPONENTS

The table below, together with the following pictures, show only those components which may be safely used with this fireplace. Two chimney designs are designated, with the appropriate components for each design. Components may not be interchanged between chimney designs. Select XT Series galvanized or stainless ("S" suffix) and follow down the column for the correct components.

Catalog Number	Description
LX	Fireplace
HX3	Hearth Extension
GR4	Integral Grate (included with Fireplace)
TK60	Trim Kit (Bright Solid Brass)
FK60	Fan Kit (Raceway and Fans)
JK60	Junction Box Kit
BC10	Motor Speed Control Kit
AC60	Air Kit - Outside Air
ID4	Insulated Duct/Outside Air
UD4	Uninsulated Duct/Outside Air
XT806	Chimney Section - 6 inch long
XT812	Chimney Section - 12 inch long
XT818	Chimney Section - 18 inch long
XT824	Chimney Section - 24 inch long
XT836	Chimney Section - 36 inch long
XT850	Chimney Stabilizer
XT830	Chimney Offset/Return - 30°
JB877	Chimney Joint Band
RT874	Chimney Terminal Cap - Round
ST875	Chimney Terminal Cap - Square
CB876	Chimney Bracket
XT838	Firestop - Straight
XT840	Firestop - 30°
XT870	Roof Flashing - Flat to 6/12 Pitch
XT871	Roof Flashing - 6/12 to 12/12 Pitch
CT35	Chase Top

### LX FIREPLACE

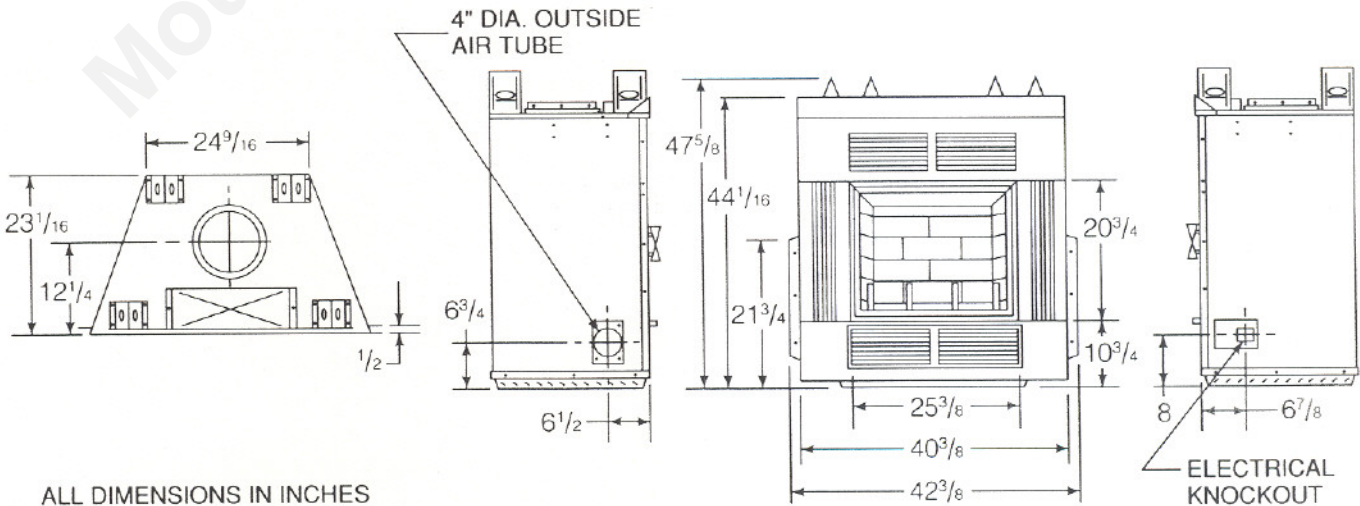

**HEARTH EXTENSION**

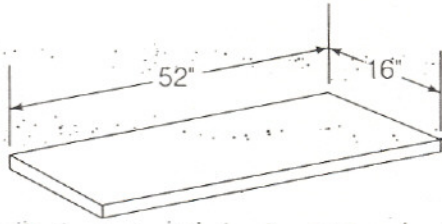

HX3

**INTEGRAL GRATE**

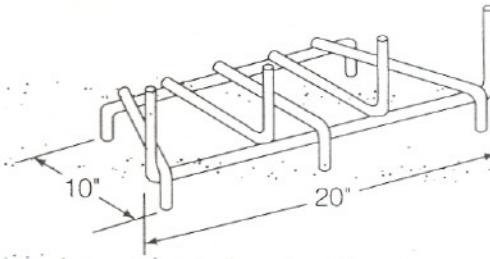

GR4

**TRIM KIT**

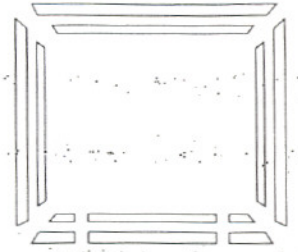

TK60

**FAN KIT**

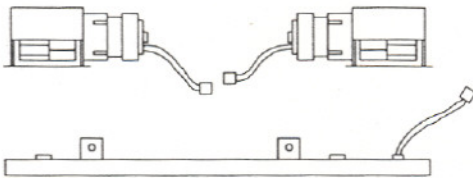

FK60

**JUNCTION BOX KIT**



JK60

**MOTOR SPEED CONTROL KIT**

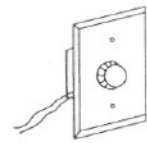

BC10

**AIR KIT**

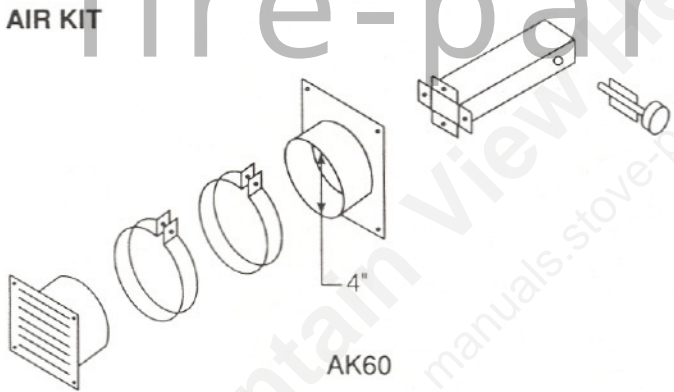

AK60

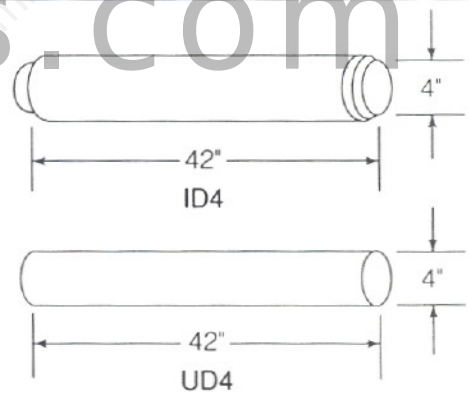

**CHIMNEY SECTIONS**

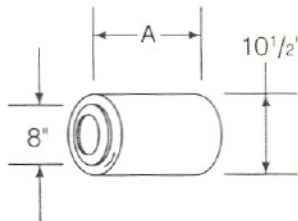

CAT. NO.	A
XT806 XT806S	6"
XT812 XT812S	12"
XT818 XT818S	18"
XT824 XT824S	24"
XT836 XT836S	36"

**CHIMNEY STABILIZERS**

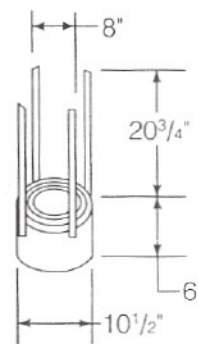

XT850  
XT850S

**OFFSETS/RETURNS**

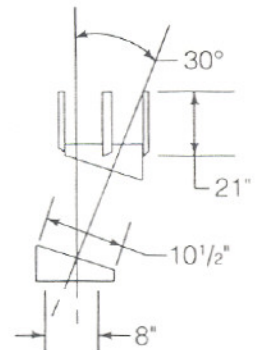

XT830  
XT830S

**JOINT BANDS**

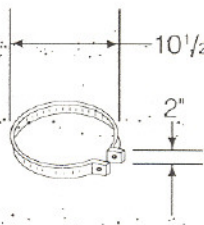

JB877  
XT877S

**CHIMNEY TERMINAL CAPS**

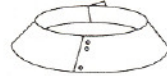
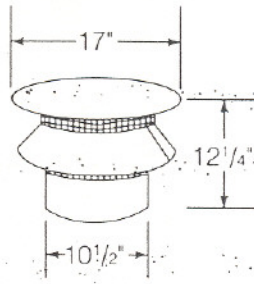

RT874  
XT874  
ROUND TERMINAL CAPS

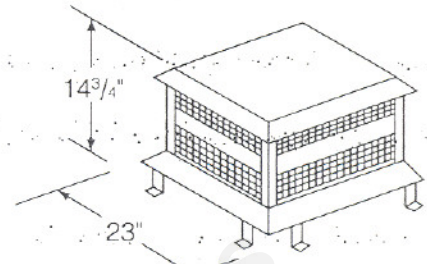

ST875  
XT875  
SQUARE TERMINAL CAPS

**CHIMNEY BRACKET**

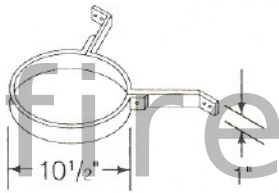

CB876

**FIRESTOP SPACERS**

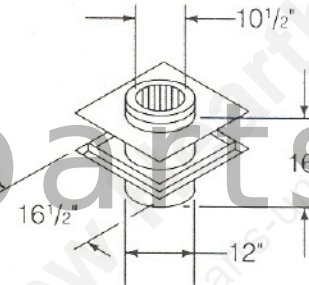

XT838

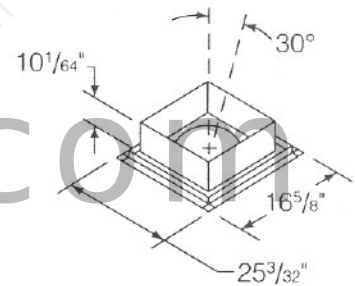

XT840

**ROOF FLASHINGS**

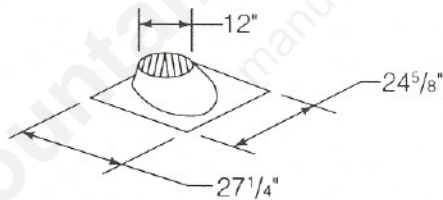

Flat to 6/12 Pitch  
XT870

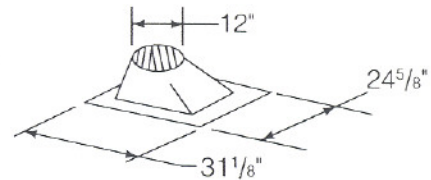

6/12 to 12/12 Pitch  
XT871

**CHASE TOP**

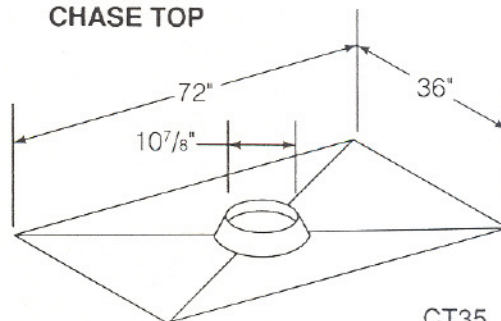

CT35

### III. FIREPLACE LOCATIONS, SPACE AND CONSTRUCTION REQUIREMENTS

The fireplace may be located as shown in Figure 1.

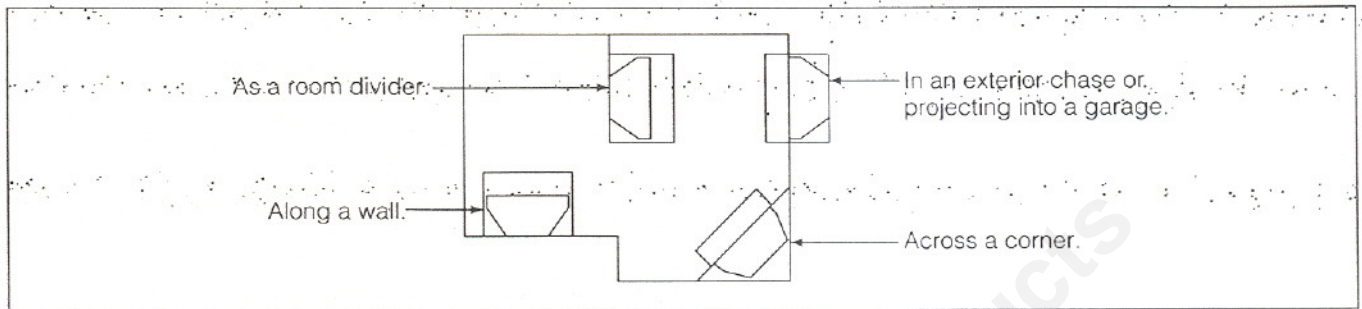

**Figure 1**  
Fireplace Locations

Figures 2 and 3 show installations assuming outside air ducts with allowance for making 90° bends. Less space is required when ducting goes directly outside without forming elbows.

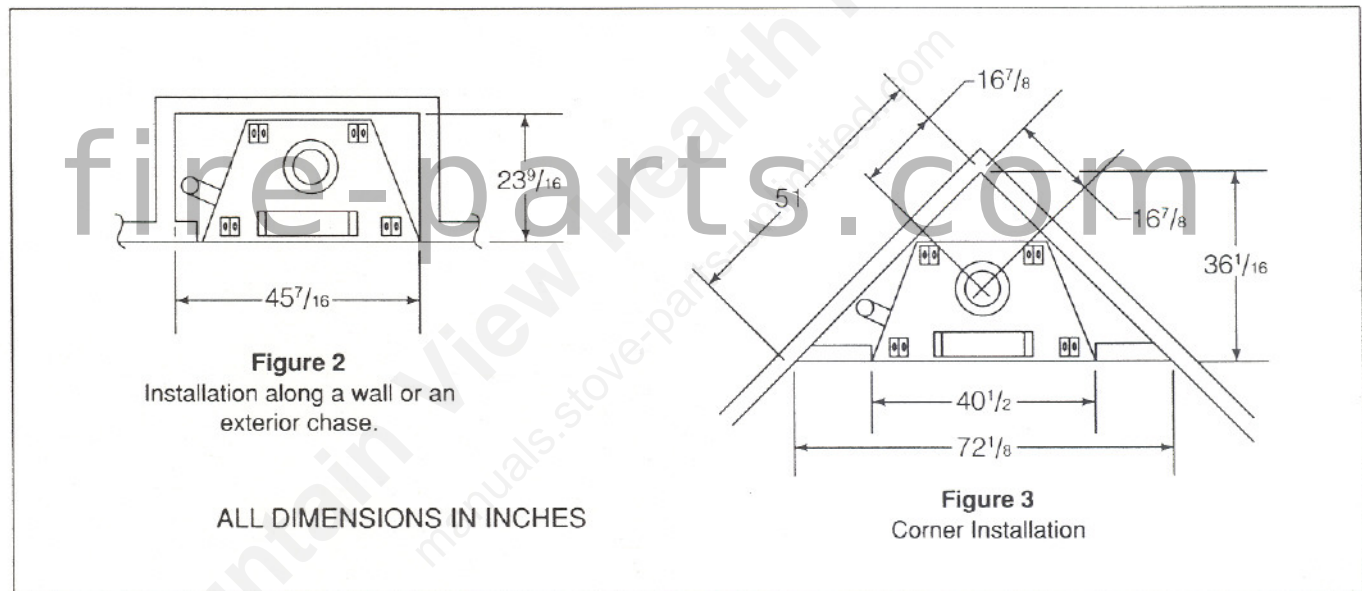

#### WARNING

**WHEN LOCATING THE FIREPLACE IN A SPACE PROJECTING INTO A GARAGE, THE OUTSIDE AIR MUST NOT BE TAKEN FROM THE GARAGE SPACE. EXHAUST PRODUCTS OF GASOLINE ENGINES ARE HAZARDOUS.**

**DO NOT INSTALL OUTSIDE AIR DUCTS SUCH THAT THE AIR MAY BE DRAWN FROM ATTIC SPACES, BASEMENTS, OR ABOVE THE ROOFING WHERE OTHER HEATING APPLIANCES OR FANS AND CHIMNEYS EXHAUST OR UTILIZE AIR. THESE PRECAUTIONS WILL REDUCE THE POSSIBILITY FOR SMOKING OR FLOW REVERSAL.**

Figure 4 shows a typical framing of the fireplace, assuming combustible materials are used. All required clearances to combustibles around the fireplace must be adhered to. Any enclosure on top of the fireplace must be above the top standoffs. Chimney Sections at any level require a minimum air space of two inches to the enclosure, including any framing, for the total chimney height.



## HEARTH EXTENSIONS

The use of factory-built Hearth Extensions is shown in Figure 5. These may be covered with a non-combustible decorative material with a maximum thickness of 15/16 inch. Seal gaps with non-combustible (sand-cement) grout or sealant.

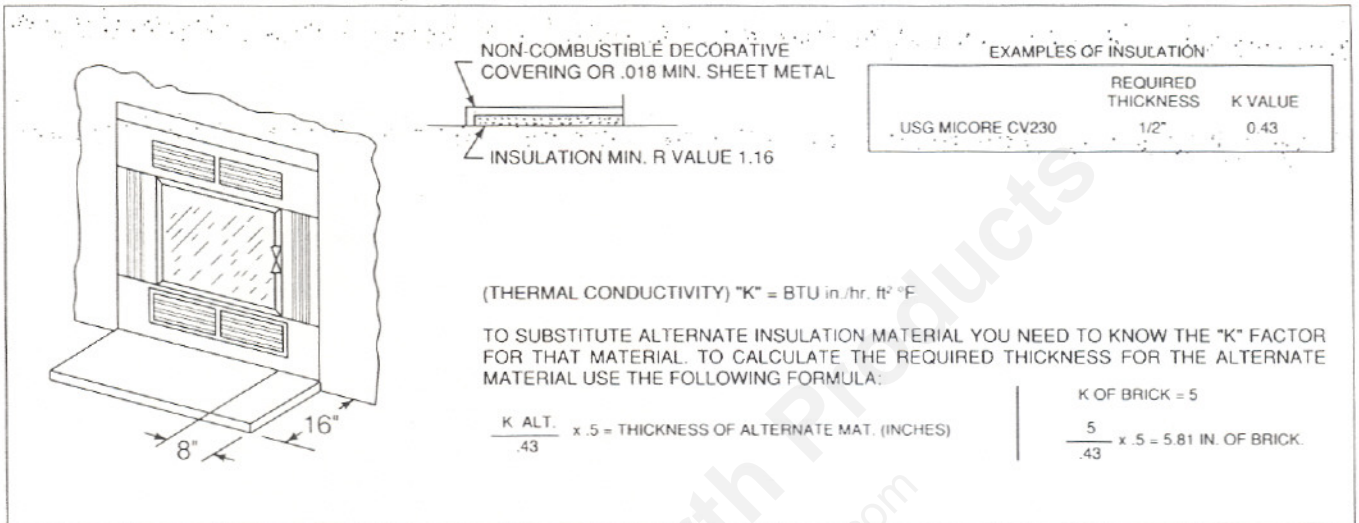

**Figure 5**  
Factory-Built Hearth Extension

Field constructed Hearth Extensions may be used, but must be constructed in accordance with the following instructions. A typical construction is shown in Figure 6. In all cases of field construction, a minimum dimension of 16" to the front and extending 8" on either side of the fireplace opening must be used, and gaps must be sealed with non-combustible (sand-cement) grout or sealant.

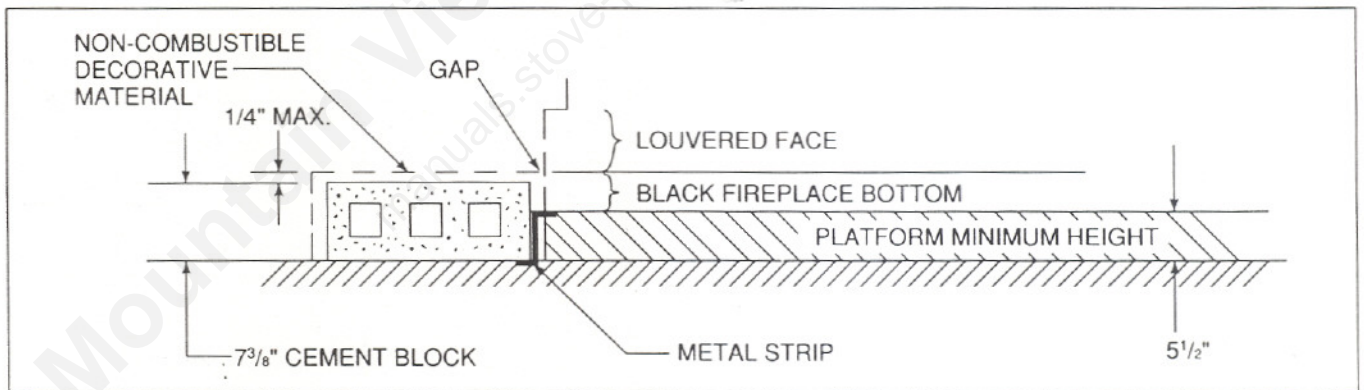

**Figure 6**  
Field Constructed Hearth Extension

A second alternative to the cement block construction shown in Figure 6 is as follows:

1. One course common brick on edge - top layer.
2. 3/8" minimum millboard - middle.
3. Standard combustible construction - base.

Both Figure 6, and the above construction, require that the fireplace be raised on a platform. A metal strip must be used between the fireplace and the field constructed Hearth Extension. Depending on the construction, a special (  ) shape may be needed. Each horizontal leg must be 2" wide and the length must be at least equal to the length of the Metal Strip provided with each fireplace. The fireplace must rest on a continuous, level surface.

## WARNING

HEARTH EXTENSIONS ARE TO BE INSTALLED ONLY AS ILLUSTRATED TO PREVENT HIGH TEMPERATURES FROM OCCURRING ON CONCEALED COMBUSTIBLE MATERIALS. METAL STRIPS PREVENT BURNING OR HOT PARTICLES FROM INADVERTENTLY FALLING DIRECTLY ON COMBUSTIBLE SURFACES IN THE EVENT THE BUILDING SHOULD SETTLE AND DISTURB THE ORIGINAL CONSTRUCTION.

## SIDEWALLS

Adjacent combustible side walls must be located a minimum of 18" from the fireplace opening. See Figure 7.

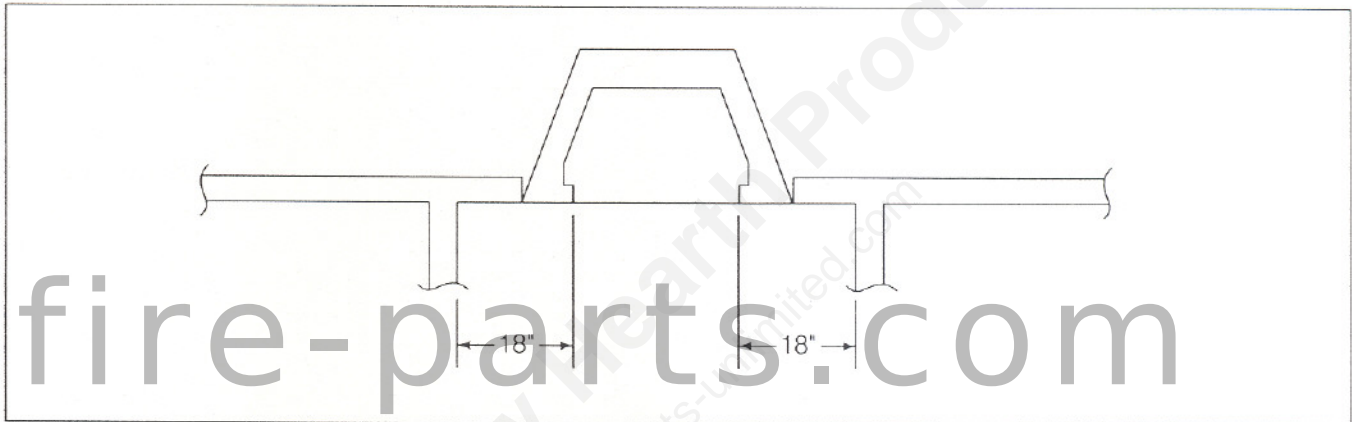

Figure 7

## MANTEL

A mantel of combustible material may be installed no less than 55" above the platform or floor upon which the fireplace is located. The mantel may extend no more than 10" from the wall.

## IV. CHIMNEY REQUIREMENTS

When planning your fireplace location, the chimney construction and necessary clearance must be considered. The fireplace system and chimney components have been tested to provide the following flexibility in construction.

Minimum straight height	15 ft.
Minimum height with Offset/Return	15 ft.
Maximum height	40 ft.
Maximum chimney length between an Offset/Return	8 ft.
Maximum distance between Chimney Stabilizers	25 ft.
Double Offset/Return minimum height	20 ft.
Maximum unsupported chimney length between Offset/Return	6 ft.
Maximum straight unsupported chimney height above firebox	12 ft.

## OFFSET INSTALLATIONS

To clear any overhead obstructions, the chimney may be offset using a 30° Offset/Return, Catalog Number XT830 or XT830S. Figure 8 and Table 1 enable selection of the appropriate chimney components when using Offsets and Returns.

1. Determine amount of offset required to extend the chimney through a wall or around an obstacle. See Figure 8, dimension "A".
2. Refer to Table 1 and find the "A" dimension closest to but not less than the amount of offset required in your installation.

TABLE 1 — 30° Offset Chart

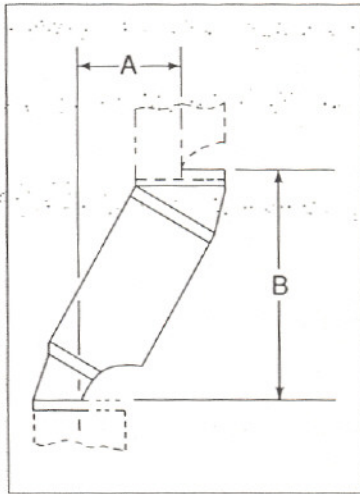

Figure 8  
Chimney Offset/Return

A	B	XT806 XT806S	XT812 XT812S	XT818 XT818S	XT824 XT824S	XT836 XT836S	JB877 XT877S
5 <sup>1</sup> / <sub>4</sub> "	13 <sup>5</sup> / <sub>8</sub> "	1					2
8 <sup>1</sup> / <sub>4</sub> "	18 <sup>3</sup> / <sub>4</sub> "	-	1	-	-	-	2
11 <sup>1</sup> / <sub>4</sub> "	24"			1			2
14 <sup>1</sup> / <sub>4</sub> "	29 <sup>1</sup> / <sub>8</sub> "	-	-	-	1	-	2
17 <sup>1</sup> / <sub>4</sub> "	34 <sup>3</sup> / <sub>8</sub> "	1			1	-	3
20 <sup>1</sup> / <sub>4</sub> "	39 <sup>1</sup> / <sub>2</sub> "	-	-	-	-	1	2
23 <sup>1</sup> / <sub>4</sub> "	44 <sup>3</sup> / <sub>4</sub> "	1	-	-	-	1	3
26 <sup>1</sup> / <sub>4</sub> "	50"	-	-	-	2	-	3
29 <sup>1</sup> / <sub>4</sub> "	55 <sup>1</sup> / <sub>8</sub> "	1	-	-	2	-	4
32 <sup>1</sup> / <sub>4</sub> "	60 <sup>3</sup> / <sub>8</sub> "	-	-	-	1	1	4
35 <sup>1</sup> / <sub>4</sub> "	65 <sup>1</sup> / <sub>2</sub> "	1	-	-	1	1	5
38 <sup>1</sup> / <sub>4</sub> "	70 <sup>3</sup> / <sub>4</sub> "	-	-	-	-	2	3
41 <sup>1</sup> / <sub>4</sub> "	75 <sup>7</sup> / <sub>8</sub> "	1	-	-	-	2	4
44 <sup>1</sup> / <sub>4</sub> "	81 <sup>1</sup> / <sub>8</sub> "	-	1	-	-	2	4
47 <sup>1</sup> / <sub>4</sub> "	86 <sup>3</sup> / <sub>8</sub> "			1		2	4
50 <sup>1</sup> / <sub>4</sub> "	91 <sup>1</sup> / <sub>2</sub> "				1	2	4

fire-parts.com

**WARNING**

**DO NOT COMBINE OFFSETS TO CREATE AN OFFSET GREATER THAN 30° FROM VERTICAL. THIS MAY CREATE A FIRE HAZARD SINCE THE NATURAL DRAFT MAY BE RESTRICTED.**

- Find the "B" dimension in Table 1 and determine if it is compatible with your installation.
- Read across the chart and find the Catalog Number and number of Chimney Sections required. The last column indicates the number of Joint Bands needed.
- Refer to Section V, Step-By-Step Installation of the Fireplace System.
- All joist areas must be Firestopped.

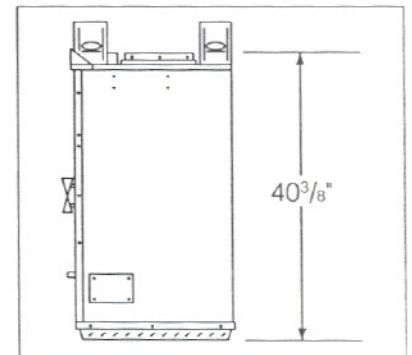

Figure 9  
Fireplace (Side View)

Figure 9 illustrates the height from the bottom of the fireplace to the top of the chimney starter.

Major building codes specify a minimum chimney height above the roof top. These specifications are summarized in what is known as the "Ten Foot Rule". This rule states:

- If the horizontal distance from the side of the chimney to the peak of the roof is 10 feet or less, the top of the chimney must be at least 2 feet above the peak of the roof, but never less than 3 feet in height above the highest point where it passes through the roof. See Figure 10.
- If the horizontal distance from the side of the chimney to the peak of the roof is more than 10 feet, a chimney height reference point is established on the surface of the roof a distance of 10 feet from the side of the chimney in a horizontal plane. The top of the chimney must be at least 2 feet above this reference point, but never less than 3 feet in height above the highest point where it passes through the roof. See Figure 11.

These chimney heights are necessary in the interest of safety and do not assure smoke-free operation. Trees, buildings, adjoining roof lines, adverse wind conditions, etc., may require a taller chimney should smoking occur.

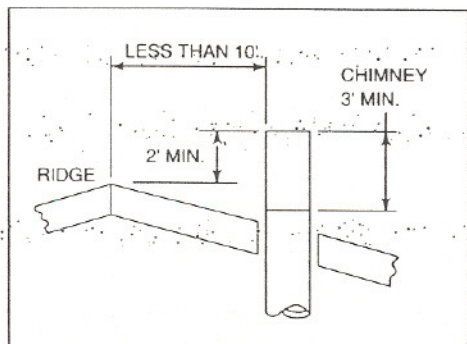

**Figure 10**  
Chimney Height

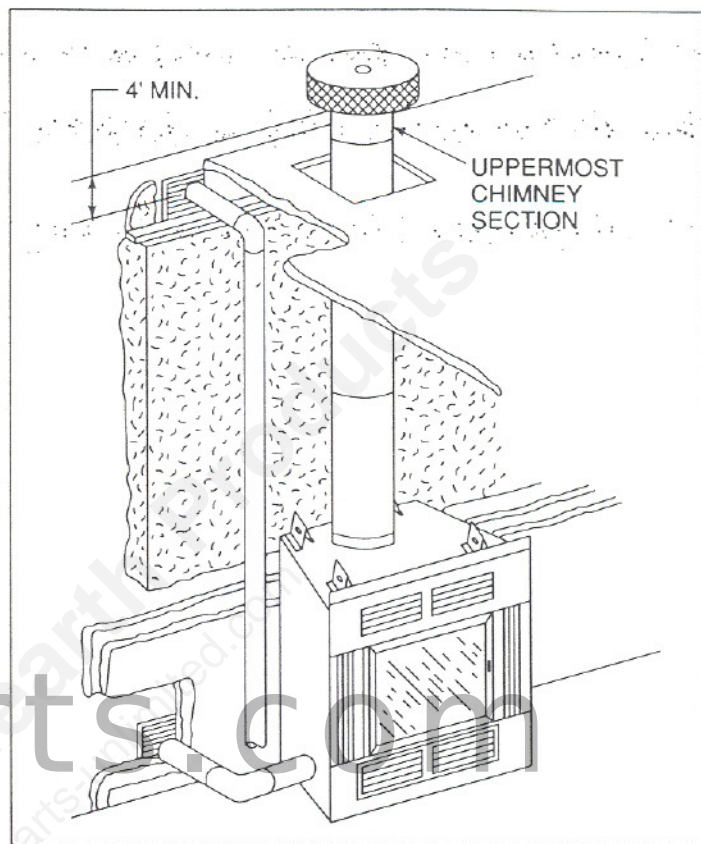

**Figure 12**  
Outside Air Locations

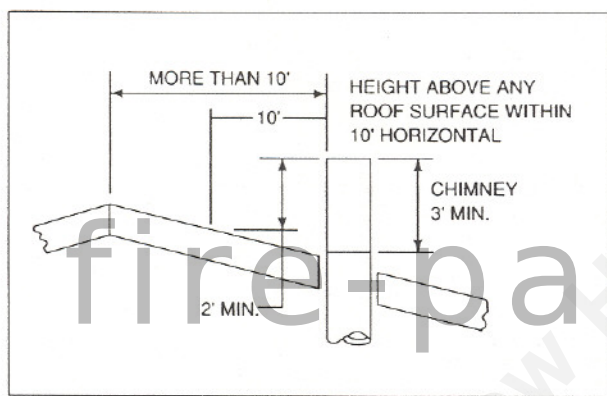

**Figure 11**  
Chimney Height

If Outside Combustion Air is used, Figure 12 illustrates only two of many possible locations - a basement fireplace with a vertical outside air arrangement; and a horizontal, direct exit from the fireplace side.

**NOTE:** A 4' minimum height difference must be maintained from the top of the uppermost Chimney Section to the Outside Combustion Air inlet.

## V. STEP-BY-STEP INSTALLATION OF THE FIREPLACE SYSTEM

### WARNING

**BEFORE STARTING, DO THE FOLLOWING:**

1. WEAR GLOVES AND SAFETY GLASSES FOR PROTECTION.
2. KEEP HAND TOOLS IN GOOD CONDITION. SHARPEN CUTTING EDGES AND MAKE SURE TOOL HANDLES ARE SECURE.
3. ALWAYS MAINTAIN THE MINIMUM AIR SPACE REQUIRED TO THE ENCLOSURE TO PREVENT FIRE.

#### STEP 1

Position the fireplace in the desired location and frame.

#### STEP 2

Slide the metal strip two inches under the front edge of the fireplace. See Figure 4. When the metal strip is not provided as a single piece, then the individual pieces must overlap each other by one inch.

### □ STEP 3

Level the fireplace side-to-side and front-to-back. Shim with non-combustible materials as necessary. Secure the fireplace by utilizing the nailing flanges located on either side of the fireplace.

#### WARNING

**CAREFULLY FOLLOW THE INSTRUCTIONS FOR ASSEMBLY OF THE PIPE AND OTHER PARTS NEEDED TO INSTALL THIS FIREPLACE SYSTEM. FAILURE TO DO SO MAY RESULT IN A FIRE, ESPECIALLY IF COMBUSTIBLES ARE TOO CLOSE TO THE FIREPLACE OR CHIMNEY AND AIR SPACES ARE BLOCKED PREVENTING THE FREE MOVEMENT OF COOLING AIR.**

### □ STEP 4

Assemble the first section to the top of the fireplace. It may be either a straight Pipe Section or an Offset. If an Offset is used, it must be turned to its final position and locked in place with size 10 sheet metal screws provided with the Offset. Drill three 1/8" holes in the fireplace collar using the predrilled Offset holes as a template. See Figure 13.

### □ STEP 5

Mark and cut out an opening in the ceiling for the particular Firestop Spacer being utilized (14 1/2" x 14 1/2" for an XT838, or 14 1/4" x 22 15/16" for an XT840). Frame the opening with the same size lumber used in the ceiling joists. See Chapter 25 of the Uniform Building Code for general construction requirements when "Framing Around Openings".

### □ STEP 6

Install the Firestop Spacer XT838 (Straight), or XT840 (30° Offset, if Offset is located in the ceiling joist area). Nail the four sides of the Firestop to the joists using a minimum of (3) nails per side. These Firestop Spacers are designed to provide the minimum two inch air space around the chimney. In all situations, the Firestops are to be nailed to the ceiling joists from the bottom or fireplace side. When the space above the ceiling is an attic space, then the top pan that comes with the Firestop must also be used. Nail the top pan from the attic side to ensure against loose or later blow-in-type insulation from falling into the required two inch air space around the chimney. See Figure 14. Firestop Spacers must be used at all ceiling levels where the chimney penetrates a living space.

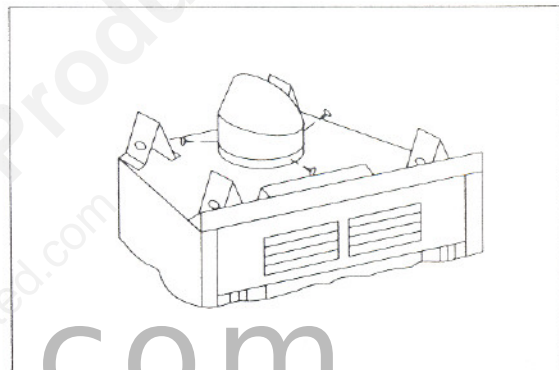

Figure 13

Offset Secured to Fireplace

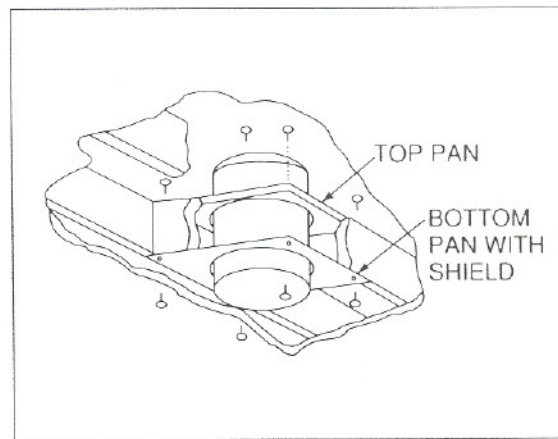

Figure 14

Straight Firestop with Top Pan

**NOTE:** Nails must always be driven so the nail head is in shear (shank is perpendicular to the chimney load). This will prevent the nail from pulling loose.

### □ STEP 7

Continue assembling Chimney Sections up through the Firestop Spacers as needed. Check height and unsupported chimney limitations described earlier.

The maximum straight unsupported height is 12 feet above the firebox and 25 feet between Chimney Stabilizers (XT850 or XT850S).

## STEP 8

When Offsets/Returns are joined to straight Pipe Sections, they must be locked in position with the size 10 sheet metal screws provided, using the predrilled holes. Offsets/Returns and Chimney Stabilizers have straps for securing these parts to joists or rafters. Plumbers tape may be purchased locally and used in conjunction with Joint Bands to secure the chimney as an alternate method. Chimney Brackets may be used to stabilize the chimney. See Figures 16 and 17.

**NOTE:** Be sure to provide intermediate support for the pipe during construction and check to be sure inadvertent loading has not dislodged the Pipe from the fireplace or at any chimney joint.

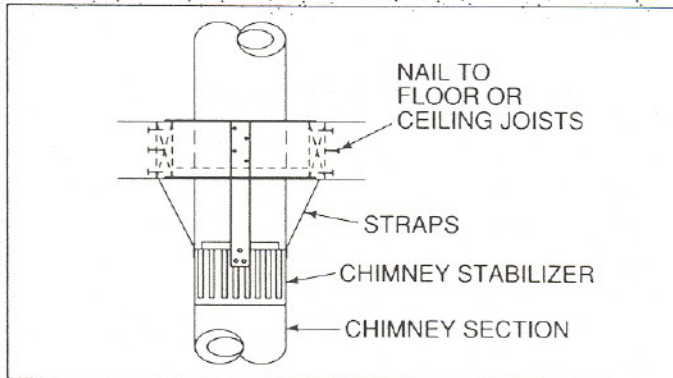

**Figure 16**  
Chimney with Stabilizer

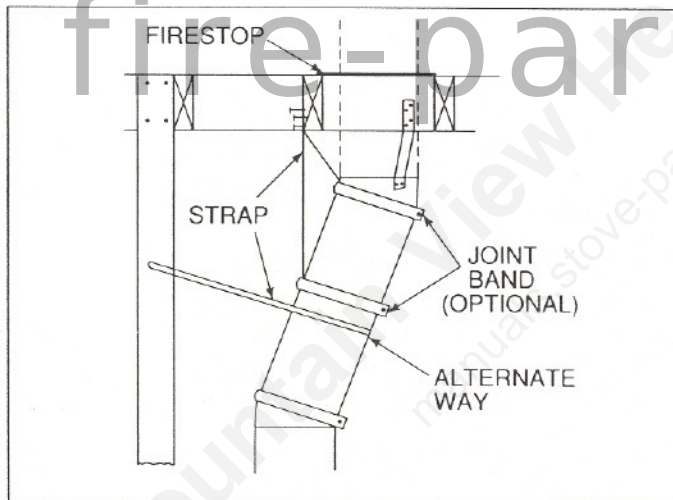

**Figure 17**  
Offset/Return Installation

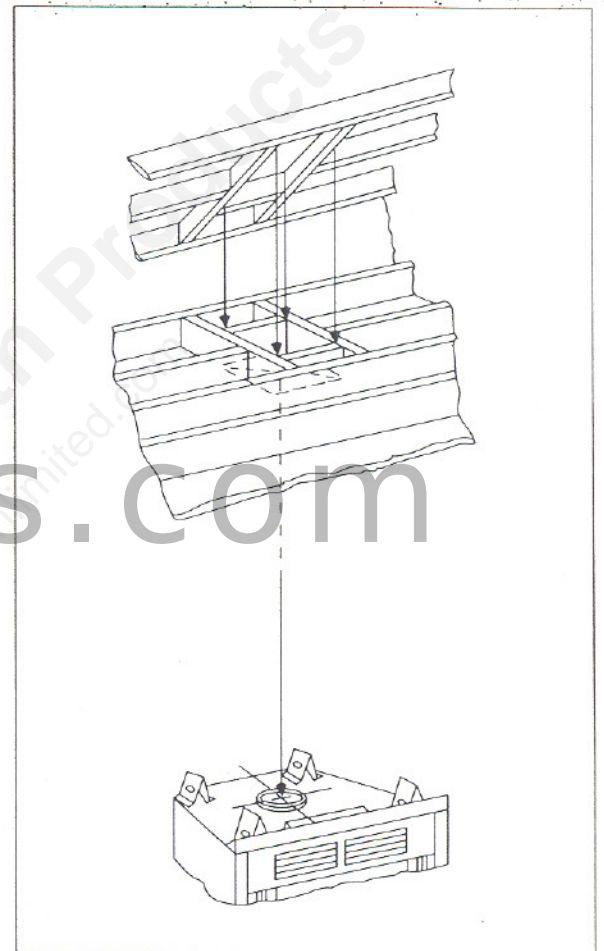

**Figure 18**  
Ceiling and Attic Construction

### WARNING

**WHEN CHIMNEY SECTIONS EXCEEDING 6 FEET IN LENGTH ARE INSTALLED BETWEEN AN OFFSET/RETURN, STRUCTURAL SUPPORT MUST BE PROVIDED TO REDUCE OFF-CENTER LOADING AND PREVENT CHIMNEY SECTIONS FROM SEPARATING AT THE CHIMNEY JOINTS.**

## STEP 9

Locate the point where the chimney will exit the roof by plumbing down to the center of the chimney. Drive a nail through the roof to mark the center. See Figure 18.

## STEP 10

Measure to either side of the nail and mark the 14 1/2" x 14 1/2" opening required. This 14 1/2" x 14 1/2" is measured on the horizontal; actual length may be larger depending on the pitch of the roof. Cut out and frame the opening. See Chapter 25 of the Uniform Building Code for Roof Framing details.

**STEP 11**

Continue to add Chimney Sections through the roof opening, maintaining at least a 2" air space.

**STEP 12**

Install the Roof Flashing appropriate to the roof pitch. Assemble the Storm Collar to protect against rain entering around the outside of the chimney, and add the Chimney Terminal Cap. The Terminal Cap must be one of the following: RT874 or XT874 (Round), ST875 or XT875 (Square).

**WARNING**

**DETAIL INSTRUCTIONS FOR INSTALLATION OF THE ROOF FLASHING, STORM COLLAR AND TERMINAL CAP ARE FOUND PACKAGED WITH THESE PARTS. TO AVOID DANGER OF FIRE, ALL INSTRUCTIONS MUST BE STRICTLY FOLLOWED, INCLUDING THE PROVISION OF AIR SPACE CLEARANCE BETWEEN CHIMNEY SYSTEM AND COMBUSTIBLE ENCLOSURE. TO PROTECT AGAINST EFFECTS OF METAL CORROSION OF THE ABOVE PARTS, FIRST WASH THEM WITH A SOLVENT OR VINEGAR, RINSE WITH WATER, AND THEN PAINT WITH A RUST RESISTANT PAINT.**

**STEP 13**

Complete the fireplace enclosure, allowing space for outside air ducts. Care must be taken with any electrical wiring to avoid exposure to high temperatures or mechanical damage to wire insulation. A minimum clearance of 1/2" must be maintained between the fireplace sides and the combustible enclosure.

**STEP 14**

Install Outside Air if desired or required by local code, using the Instructions supplied with the AK60 Air Kit. The use of Outside Air is strongly recommended.

**STEP 15**

If a Fan Kit is desired, first install the Junction Box Kit, using the Instructions supplied in the JK60 Kit. Fan Kit FK60 can only be installed after the JK60 Junction Box Kit has been installed. Follow the Instructions supplied with the Fan Kit for proper installation. It is recommended to install the JK60 Junction Box Kit during initial construction even if fans are not initially desired - this allows for adding a Fan Kit at a later date.

**WARNING**

**DISCONNECT POWER BEFORE STRIPPING OR JOINING ANY SUPPLY WIRES. ONLY PERSONS QUALIFIED FOR MAKING ELECTRICAL INSTALLATIONS (ELECTRICIANS) AS RECOGNIZED BY LOCAL OR NATIONAL GOVERNMENTAL BODIES SHOULD ATTEMPT TO MAKE THE INCOMING SUPPLY WIRE CONNECTIONS.**

**EDGES ARE SHARP. HAND PROTECTION IS RECOMMENDED. RECHECK ALL FASTENERS BEFORE LEAVING JOB.**

**NOTE:** A Motor Speed Control Kit, Catalog Number BC10, is available for use with this Fan Kit. Refer to the Instructions packed with it for proper installation. If a speed control option is desired, it is recommended to use the BC10 Kit to insure proper function.

**STEP 16**

Position the Hearth Extension over the metal protective strip which should project two inches in front of the fireplace bottom front. See Figure 4. Seal the crack between the Hearth Extension and fireplace with a non-combustible (sand-cement) grout or sealant.

**STEP 17**

Apply the finish materials of your choice. Do not install combustible materials over the black face of the fireplace or louvered openings. You may use non-combustible material over the black - non-louvered - face of the fireplace.

**STEP 18**

This fireplace is equipped with a factory installed Integral Grate. In the event it becomes necessary to replace it, remove the pin from the leg of the back bar, using a vise grip to pull it free. Lift the Grate so the legs will come free of the retaining brackets. Your new Grate will be supplied with a new pin. Remove this pin and position the Grate into the brackets located at the rear of the firebox, and replace the pin into the leg of the Grate bar. Use only Catalog Number GR4 Integral Grate for replacement.

**STEP 19**

Prior to building your first fire in your fireplace, please read the "Operating Instructions" section that follows.

**WARNING**

**DONOT PACK REQUIRED AIR SPACES WITH INSULATION OR OTHER MATERIALS. THIS PREVENTS THE NATURAL CONVECTION COOLING WHICH MUST TAKE PLACE. THE REQUIRED CLEARANCES ARE TO THE ENCLOSURE AND SHOULD NOT BE REDUCED BY THE ADDITION OF OTHER MATERIALS WHETHER OF NON-COMBUSTIBLE OR COMBUSTIBLE MATERIAL. COMBUSTIBLE MATERIALS AS WELL AS THE NON-COMBUSTIBLE MATERIALS USED IN THE FIREPLACE MAY HAVE THEIR USEFUL LIFE REDUCED.**

**VI. CONSTRUCTING A CHASE**

The chase may be constructed for the fireplace and chimney or for the chimney only. A chase is an enclosure built around the system. It is most commonly constructed on an outside wall as shown below.

Three examples of chase applications are shown in Figure 19.

1. Fireplace and chimney enclosed in chase - exterior.
2. Chimney offset through exterior wall and enclosed in chase.
3. Chase constructed on roof.

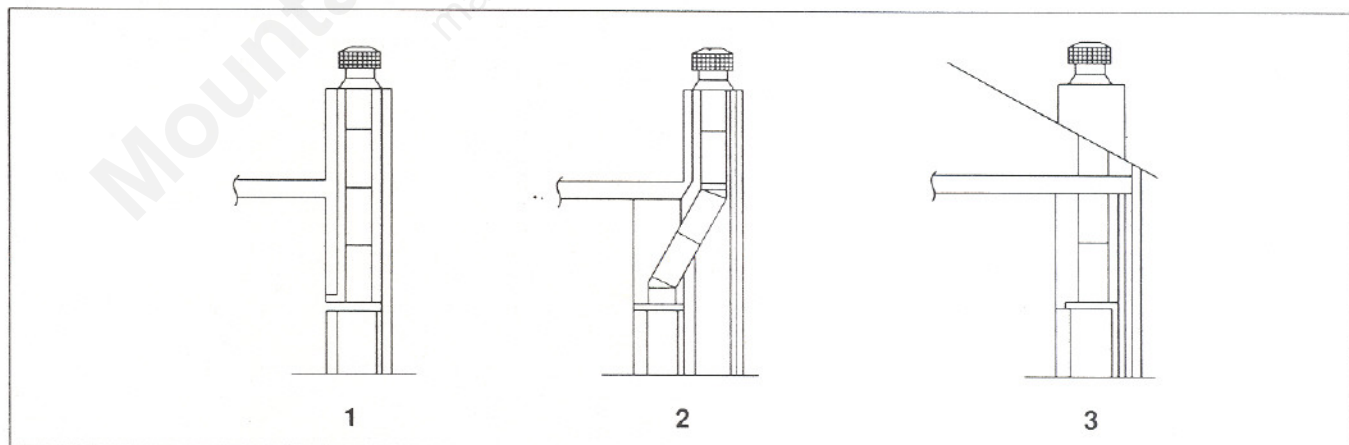

**Figure 19**  
Chase Constructions

**MATERIALS FOR CHASE**

The chase is constructed much the same as the walls in your home. A variety of materials may be used including brick, stone, veneer brick, or standard siding materials.

In constructing the chase, several factors must be considered.

1. Maintain a 2" air space clearance around the chimney.
2. The Chase Top must be constructed of a non-combustible material.
3. The walls of the chase must be insulated to prevent heat leaking from the home around and through the fireplace.

#### **TO INSTALL TERMINAL CAP ON CHASE - ENCLOSED CHIMNEY**

1. Construct chase of desired materials maintaining a minimum 2" air space around the chimney.

#### **WARNING**

**NEVER INSTALL A SINGLE WALL SLIP SECTION OR SMOKE-PIPE IN A CHASE STRUCTURE. THE HIGHER TEMPERATURE OF THIS SINGLE WALL PIPE MAY RADIATE SUFFICIENT HEAT TO COMBUSTIBLE CHASE CONSTRUCTION MATERIALS TO CAUSE A FIRE.**

2. Install the Chimney Sections up through the chase. When using a Round Terminal Cap (RT874 or XT874), the last section of Pipe must extend above the Chase Top to allow installation of the Storm Collar and Terminal Cap. If a Square Terminal Cap (ST875 or XT875) is utilized, see separate Installation Instructions.

#### **WARNING**

**DETAIL INSTRUCTIONS FOR INSTALLATION OF THE CHASE TOP, STORM COLLAR AND TERMINAL CAP ARE FOUND PACKAGED WITH THESE PARTS. TO AVOID DANGER OF FIRE, ALL INSTRUCTIONS MUST BE STRICTLY FOLLOWED, INCLUDING THE PROVISION OF AIR SPACE CLEARANCE BETWEEN CHIMNEY SYSTEM AND COMBUSTIBLE ENCLOSURE AND BETWEEN CHASE AND CHASE TOP. TO PROTECT AGAINST EFFECTS OF METAL CORROSION OF PARTS SUCH AS CHASE TOP AND THOSE ABOVE CHASE TOP, FIRST WASH THEM WITH A SOLVENT OR VINEGAR, RINSE WITH WATER, AND THEN PAINT WITH A RUST RESISTANT PAINT.**

3. Attach the Chase Top (CT35) to the top of the chase.
4. If a Round Terminal Cap (RT874 or XT874) is to be utilized, loosen the bolt on the Storm Collar and slide it down over the Pipe to the Chase Top. Tighten the bolt and seal around the Collar.
5. Attach and secure either a Round or Square Terminal Cap.

## **OPERATING INSTRUCTIONS**

#### **WARNING**

**DO NOT ATTEMPT TO OPERATE THIS FIREPLACE WITHOUT READING AND UNDERSTANDING THESE OPERATING INSTRUCTIONS THOROUGHLY. FAILURE TO OPERATE THIS APPLIANCE PROPERLY MAY CAUSE A SERIOUS HOUSE FIRE.**

**NOTICE:** Save and pass these Operating Instructions and the Installation Instructions to subsequent owners. The information provided is intended to notify and warn them about making unsafe future modifications such as the addition of shelves or the use of unauthorized parts and repairs.

**CAUTION: Edges are sharp. Hand protection is recommended.**

The HEATILATOR® Model LX Fireplace is an efficient woodburning appliance designed to burn natural, seasoned wood. Do not burn artificial logs or driftwood.

A manual draft slide control located below the fireplace loading door regulates the amount of combustion air available to the fire, thus controlling the rate of burn. Moving the draft slide all the way to the right opens the air intake. Moving it to the left closes it. The more combustion air allowed into the firebox, the hotter and faster the fire will burn. Closing the air intake slows the rate of combustion resulting in a slower burning fire. Experience with your fireplace, the quality of your firewood and local conditions will determine the proper draft slide setting for maintaining the heat output that best suits your needs.

**BREAK-IN PERIOD.** Build your first few fires small to allow the high temperature paint on your fireplace to cure. During this period excessive temperatures may damage the paint. Allow adequate ventilation to dissipate smoke and odor that may come from the paint during curing.

**STARTING THE FIRE.** NOTE: Build the fire directly on the Integral Grate. Be sure the ash pan door is closed and securely latched.

**CAUTION: Never use gasoline, gasoline-type lantern fuel, kerosene, charcoal lighter fluid, or similar liquids to start or 'freshen up' a fire in this fireplace. Keep all such liquids well away from the fireplace while it is in use to avoid the risk of fire.**

1. Place several crumpled newspaper pages (at least 6) on the firebox floor.
2. Cover the paper with several pieces of kindling. The kindling should be less than 1" in diameter, well seasoned, dry split firewood.
3. Move the draft slide control all the way to the right to open the air intake.
4. Light the newspaper in several places, starting at the back of the firebox and working towards the front.
5. Close the door to prevent smoke spillage BUT DO NOT LATCH. This allows extra air into the firebox for start-up while pre-heating the glass to help keep it cleaner.
6. Maintain the fire by adding kindling periodically until a uniform fire bed has been established (approximately 5-10 minutes.)
7. After establishing a fire bed, add a few small pieces of firewood, two to three inches in diameter, to the fire. Place the wood in such a manner to allow combustion air and flames between them.

NOTE: If the chimney flue is cold due to low outside temperatures, several pieces of crumpled paper on TOP of the fuel can help to establish a draft in the flue. Light this paper when lighting the kindling in step 5.

#### WARNING

**DO NOT LEAVE FIRE UNATTENDED WHEN THE DOOR IS UNLATCHED. CARELESSLY PLACED FIREWOOD COULD FALL OUT OF THE FIREBOX CREATING A FIRE HAZARD.**

8. When the kindling is consumed and the firewood is burning briskly (about 5 to 10 minutes) add a minimum of three average sized pieces of split firewood. Close the door and latch it securely.

**CAUTION: Do not slam fireplace door or otherwise impact the glass. When closing door, make sure that logs or other objects do not protrude to impact against the glass.**

9. After about 45 minutes to 1 hour, the fireplace will have reached operating temperature. You may slow down the burn rate by adjusting the temperature setting to the left. If equipped with the optional blower, turn it on and adjust the speed as desired.

**WARNING**

**ALWAYS OPERATE THIS APPLIANCE WITH THE DOOR CLOSED AND LATCHED EXCEPT DURING START-UP AND RE-FUELING.**

**RE-FUELING.** When adding fresh wood to an existing fire:

1. Open the air intake by moving the control level all the way to the right (HI).
2. Wait a few seconds, then open the door slowly.

**CAUTION:** Always open the door slowly while the fire is burning to avoid smoke and flame spillage. It is best to unlatch the door, wait a few seconds, then open the door slowly.

If the fire has been allowed to die down between re-fueling it may be necessary to use smaller pieces of wood to rekindle it. Leave the temperature setting on HI after re-fueling for 10 to 20 minutes to re-establish a moderately high firing rate and bring the appliance back up to operating temperature.

**WARNING**

**CONTINUED OVERFIRING CAN PERMANENTLY DAMAGE YOUR FIREPLACE SYSTEM. EXAMPLES OF OVERFIRING ARE:**

1. QUANTITIES OF SCRAP LUMBER, PINE BRANCHES OR CARDBOARD BOXES WHICH EXCEED THE VOLUME OF THE "NORMAL LOG FIRE". THESE MATERIALS PRODUCE MANY SPARKS AND MUST NOT BE USED.
2. THE "NORMAL LOG FIRE" IS THREE LOGS, EACH FOUR INCHES IN DIAMETER, WITH THE LENGTH NO GREATER THAN THE BACK WALL OF THE FIREPLACE. THE RATE OF FIRING MUST NOT EXCEED THESE THREE LOGS PER HOUR.

**ASH DISPOSAL.** Ashes must be cleared or removed when accumulation approaches the top of the ash pan or obstructs draft flow through the holes in the grate.

To clean, open the ash pan access door by twisting the round wood door lock knob clockwise. Slide the ash pan out and remove the ashes with a metal fireplace shovel. The ash pan can also be removed from the fireplace completely to facilitate cleaning. If removed, place the pan on a non-combustible surface. For your safety, wear padded non-flammable hand and arm protection while clearing ashes. See Figure 20.

Ashes should be placed in a metal container with a tight fitting lid. The closed container of ashes should be placed on a non-combustible floor or on the ground, well away from all combustible materials, pending final disposal. The ashes should be retained in the closed container until all cinders have thoroughly cooled.

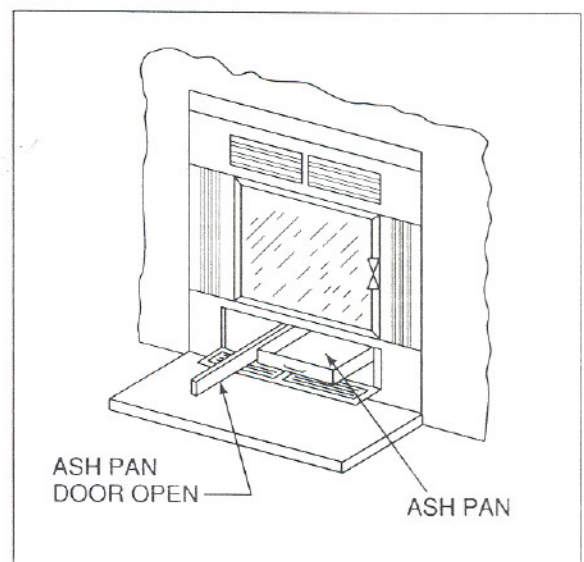

Figure 20

**WARNING**

**ASHES SHOULD NEVER BE PLACED IN WOODEN OR PLASTIC CONTAINERS, OR IN PAPER OR PLASTIC BAGS, REGARDLESS OF HOW LONG THE FIRE HAS BEEN OUT. COALS HAVE BEEN FOUND TO STAY HOT FOR SEVERAL DAYS WHEN EMBEDDED IN ASHES.**

**WARNING**

**DO NOT OPERATE FIREPLACE WITH ASH PAN ACCESS DOOR OPEN. OVERFIRING MAY RESULT WHICH CAN DAMAGE THE FIREPLACE AND IGNITE CREOSOTE IN THE CHIMNEY, POSSIBLY CAUSING A HOUSE FIRE.**

**CREOSOTE & SOOT - Formation and need for removal.** When wood is burned slowly, it produces tar and other organic vapors, which combine with expelled moisture to form creosote. The creosote vapors condense in the relatively cool chimney flue of a newly started fire or from a slowly burning fire. As a result, creosote residue accumulates on the flue lining. When ignited, this creosote makes an extremely hot fire which may damage the chimney or even destroy the house.

The chimney connector and chimney should be inspected at least twice monthly during the heating season to determine if a creosote or soot build-up has occurred. If so, it should be removed to reduce the risk of a chimney fire.

To help prevent creosote build-up, always burn dry, well seasoned firewood. When refueling after an extended low burn rate, allow the appliance to burn with the combustion air intake fully open (temperature setting on HI) for 10 to 20 minutes to burn off creosote deposits that accumulate during the low burn.

The creosote and soot should be removed with a brush specifically designed for the type of chimney in use. A chimney sweep can perform this service. It is also recommended that before each heating season the entire system be professionally inspected, and cleaned and repaired if necessary.

**WARNING**

**FAILURE TO INSPECT AND CLEAN YOUR CHIMNEY SYSTEM REGULARLY CAN RESULT IN A SERIOUS FIRE WHICH MAY DAMAGE THE CHIMNEY OR CAUSE A HOUSE FIRE.**

**DOOR GASKET.** Check the door gasket periodically for proper seal. Wear or damage to the gasket material can cause air leakage into the firebox resulting in overfiring and loss of efficiency.

Replace the gasket, when necessary, with 5/8" diameter woodstove gasket material available from your local woodstove retailer or order Catalog Number GK1 Firedoor Gasket Kit from your nearest HEATILATOR® dealer. The Firedoor Gasket Kit comes complete with gasket material, high temperature adhesive and instructions.

**WARNING**

**DO NOT OPERATE THIS FIREPLACE IF THE DOOR GASKET IS MISSING OR DAMAGED. DANGEROUS OVERFIRING CAN OCCUR WHICH CAN DAMAGE THE APPLIANCE OR IGNITE CREOSOTE IN THE CHIMNEY, POSSIBLY CAUSING A HOUSE FIRE.**

**DOOR GLASS.** Inspect the glass regularly for cracks or breaks. If you detect a crack or break, extinguish the fire immediately and contact your HEATILATOR® dealer for replacement.

## WARNING

**DO NOT OPERATE THE FIREPLACE IF THE DOOR GLASS IS BROKEN OR MISSING. DANGEROUS OVERFIRING CAN OCCUR WHICH CAN DAMAGE THE APPLIANCE OR IGNITE CREOSOTE IN THE CHIMNEY, POSSIBLY CAUSING A HOUSE FIRE.**

A portion of the combustion air entering the firebox is deflected down over the inside of the door glass. This air flow "washes" the glass helping to keep smoke from adhering to its surface.

When operated at a low burn rate less air will be flowing over the glass and the smokey, relatively cool condition of a low fire will cause the glass to become coated. If the deposits on the glass are not very heavy, normal glass cleaners work well. Heavier deposits may be removed by using a damp cloth dipped in wood ashes or by using a commercially available oven cleaner. After using an oven cleaner, it is advisable to remove any residue with a glass cleaner or soap and water. Oven cleaner left on during the next firing can permanently stain the glass and damage the finish on plated metal surfaces.

**CAUTION: Take care when using oven cleaners as they may be caustic. Always follow label instructions and warnings.**

Do not clean the glass with materials that may scratch or otherwise damage the glass. Scratches on the glass can develop into cracks or breaks. Never attempt to clean the glass while a fire is in the unit.

The best way to keep the glass clean is to operate the fireplace efficiently by using dry, well seasoned wood and burning moderate to hot fires.

**OUTSIDE AIR.** A damper allows individual control of the Outside Air inlets if your fireplace is equipped with this option. In a tightly sealed or well insulated home, replacement of combustion air is necessary to keep harmful gases from entering living spaces.

**GRATE.** The factory installed Integral Grate must be used to hold the logs from falling out of an open fireplace and to allow air to pass between the burning logs. It is important to keep the fire off the hearth and to allow the ashes to collect beneath the fire. Use only Catalog Number GR4 Integral Grate for replacement.

**FAN KIT.** HEATILATOR® FK60 Heat Circulating Fans may be used with this fireplace. An external ON/OFF switch must be provided, or a Motor Speed Control BC10, may be used. Using these fans will increase efficiency and heat output.

**SAFETY - A FINAL WORD.** Fireplaces as well as other woodburning appliances have been used safely for many years. Our own experience is that most problems are caused by improper installation, fueling, and operating. All dimensions specified are minimum and increasing distances to combustibles decreases risk. Such common practices as surrounding the fireplace with loose fill insulation, and especially leaving the fire unattended, will increase the risk of fire. Additionally, an annual inspection of all fireplace systems should be performed as, like any appliance, minor repairs may be required to maintain the system in top operating condition.



# *Attention* **Fireplace Installer:**

*Please return operating  
and installation  
instructions to the firebox  
for consumer use.*

**heatilator**  
*The first name in fireplaces*