



The first name in fireplaces

Heatilator Inc
1915 W. Saunders Street
Mt. Pleasant, IA 52641
a HON INDUSTRIES company

NA36AI NA42AI INSTALLATION & OPERATING INSTRUCTIONS FOR RESIDENTIAL USE

I. LISTINGS AND CODE APPROVALS

These fireplace systems have been tested in accordance with Underwriters Laboratories Inc. Standards, and have been LISTED by them for installation and operation as described in these Installation & Operating Instructions.

Fireplace Catalog Numbers NA36AI and NA42AI have been tested and LISTED for use with the Optional Components described in Section II of these Instructions. These Optional Components may be purchased separately and installed at a later date. However, installation of the Outside Air Kit, Junction Box Kit and Fan Kit will require significant reconstruction, and should be installed at the time of initial installation.

Check with your local building code agency before you begin installation to ensure compliance with local codes, including the need for "permits" and follow-up inspections. If any problems are encountered regarding code approvals, or if you wish clarification of any of the instructions contained here, contact: Customer Relations Department, Heatilator Inc., 1915 W. Saunders Street, Mt. Pleasant, Iowa 52641. HEATILATOR® is a registered trademark of Heatilator Inc., a HON INDUSTRIES company.

WARNING

THIS HEATILATOR FIREPLACE AND ITS COMPONENTS ARE DESIGNED TO BE INSTALLED AND OPERATED AS A SYSTEM. ANY ALTERATION TO OR SUBSTITUTION FOR ITEMS IN THIS SYSTEM UNLESS ALLOWED BY THESE INSTALLATION INSTRUCTIONS WILL VOID THE UNDERWRITERS LABORATORIES LISTING AND MAY VOID THE PRODUCT WARRANTY. IT MAY ALSO CREATE A HAZARDOUS INSTALLATION. READ THROUGH THESE INSTRUCTIONS THOROUGHLY BEFORE STARTING YOUR INSTALLATION AND FOLLOW THEM CAREFULLY THROUGHOUT YOUR PROJECT.

II. DESCRIPTION OF THE FIREPLACE SYSTEM

The HEATILATOR® fireplace system consists of the following:

1. Fireplace
2. Hearth Extension
3. Chimney System
4. Roof Termination
5. Integral Grate

Optional components Include:

1. Glass Doors
2. Outside Combustion Air System
3. Heat Circulating Fans

THE FIREPLACE SYSTEM COMPONENTS

The table below, together with the following pictures, show only those components which may be safely used with these fireplaces.

Catalog Number		Description
NA36AI	NA42AI	Fireplaces (Insulated Outer Shell)
HX3	HX4	Hearth Extensions
GD36A	GD42A	Glass Doors - Clear-View, Antique Solid Brass
GD36B	GD42B	Glass Doors - Clear-View, Bright Solid Brass
GA36A	None	Glass Doors - Cabinet, Antique Solid Brass
GA36B	None	Glass Doors - Cabinet, Bright Solid Brass
C1136A	C1142A	Classic Bifold Glass Doors - Brushed Brass Finish
C1136B	C1142B	Classic Bifold Glass Doors - Polished Brass Finish
C1136C	C1142C	Classic Bifold Glass Doors - Chrome Finish
C2136A	C2142A	Classic Cabinet Glass Doors - Brushed Brass Finish
C2136B	C2142B	Classic Cabinet Glass Doors - Polished Brass Finish
C2136C	C2142C	Classic Cabinet Glass Doors - Chrome Finish
D1136B	D1142B	Designer Series Bifold Glass Doors - Polished Brass Finish
D2136B	D2142B	Designer Series Cabinet Glass Doors - Polished Brass Finish
GR1	GR2	Integral Grate (included with Fireplace)
FK1		Fan Kit (Raceway and Single Fan)
FK2		Fan Kit (Single Fan)
JK1		Junction Box Kit
BC10		Motor Speed Control Kit
AK14		Air Kit - Outside Air
ID4		Insulated Duct/Outside Air
UD4		Uninsulated Duct/Outside Air
SL306		Chimney Section - 6 inch long
SL312		Chimney Section - 12 inch long
SL318		Chimney Section - 18 inch long
SL324		Chimney Section - 24 inch long
SL336		Chimney Section - 36 inch long
SL348		Chimney Section - 48 inch long
SL3		Chimney Stabilizer
SL315		Chimney Offset/Return - 15°
SL330		Chimney Offset/Return - 30°
FS338		Firestop - Straight
FS339		Firestop - 15°
FS340		Firestop - 30°
JB877		Chimney Joint Band
CB876		Chimney Bracket
RF370		Roof Flashing - Flat to 6/12 Pitch
RF371		Roof Flashing - 6/12 to 12/12 Pitch
RT362		Telescoping Chimney Terminal Cap - Round
RT364		Chimney Terminal Cap - Round
RT364S		Chimney Terminal Cap, Stainless Steel - Round
RT382		Telescoping Chimney Terminal Cap - Round
RT384		Chimney Terminal Cap - Round
ST375		Chimney Terminal Cap - Square
ST376		Telescoping Chimney Terminal Cap - Square
ST8		Housing Top Chimney Terminal Cap
RB4		4' Simulated Red Brick Chimney Panels
TB4		4' Simulated Tan Brick Chimney Panels
RB6		6' Simulated Red Brick Chimney Panels
TB6		6' Simulated Tan Brick Chimney Panels
CT35		Chase Top

NA36AI & NA42AI FIREPLACES

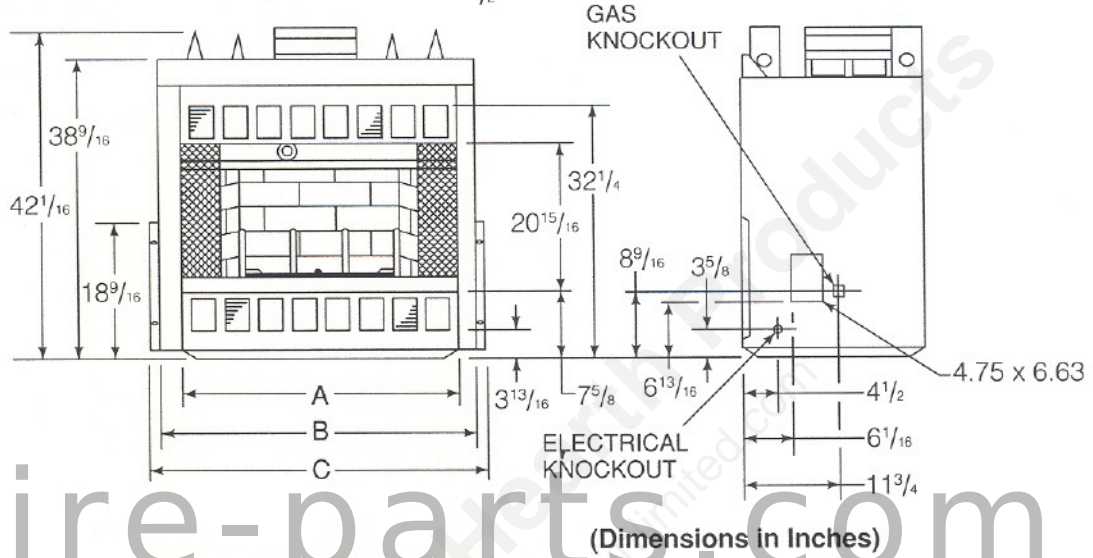
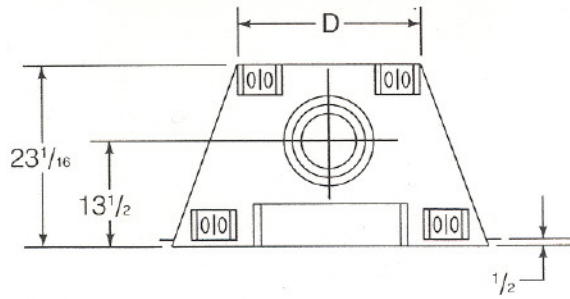

(Dimensions in Inches)

CAT. NO.	A	B	C	D
NA36AI	36	41	43	$24\frac{9}{16}$
NA42AI	42	47	49	$30\frac{9}{16}$

HEARTH EXTENSIONS

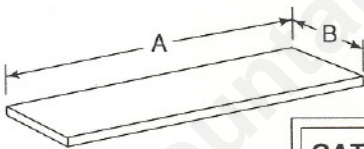

CAT. NO.	A	B
HX3	52"	16"
HX4	66"	20"

GLASS DOORS

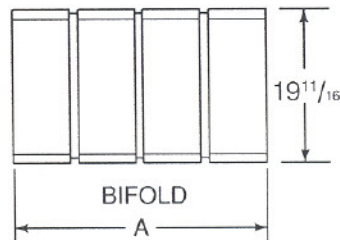

CAT. NO.	A
GD36A	$34\frac{13}{16}$ "
GD36B	$34\frac{13}{16}$ "
GD42A	$40\frac{15}{16}$ "
GD42B	$40\frac{15}{16}$ "

INTEGRAL GRATES

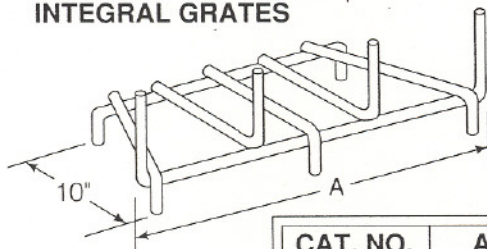

CAT. NO.	A
GR1	20"
GR2	26"

FAN KITS

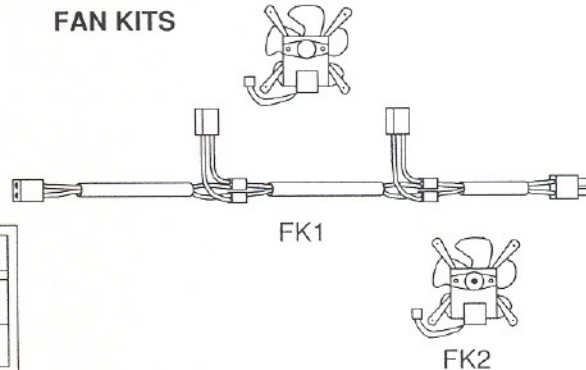

JUNCTION BOX KIT

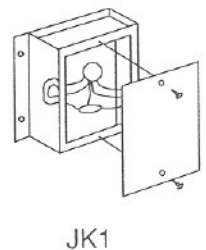

AIR KIT

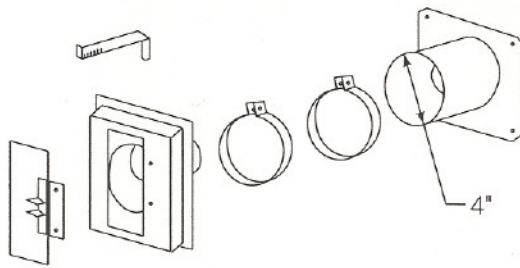

AK14

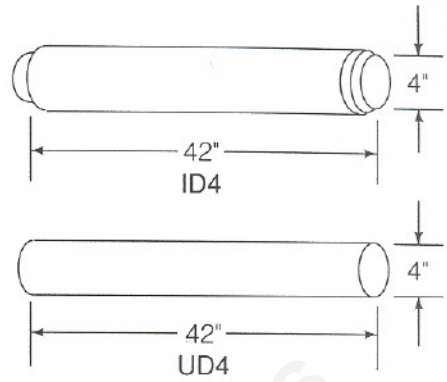

CHIMNEY SECTIONS

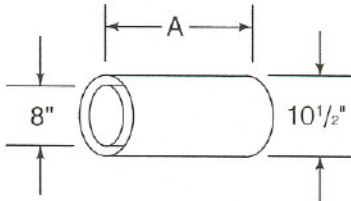

CAT. NO.	A
SL306	6"
SL312	12"
SL318	18"
SL324	24"
SL336	36"
SL348	48"

CHIMNEY STABILIZER

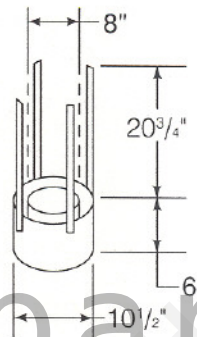

SL3

OFFSETS/RETURNS

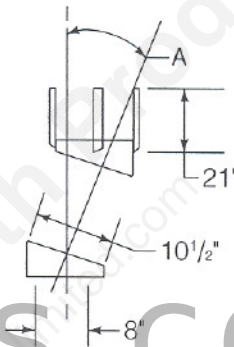

SL315
SL330

CAT. NO.	A
SL315	15°
SL330	30°

FIRESTOP SPACERS

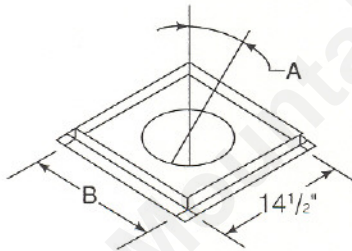

CAT. NO.	A	B
FS338	0°	14 1/2"
FS339	15°	18 3/8"
FS340	30°	22 15/16"

JOINT BAND

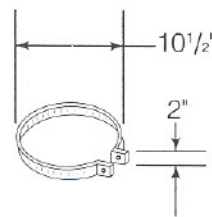

JB877

CHIMNEY BRACKET

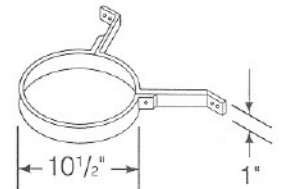

CB876

ROOF FLASHINGS

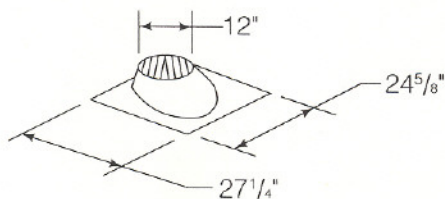

Flat to 6/12 Pitch
RF370

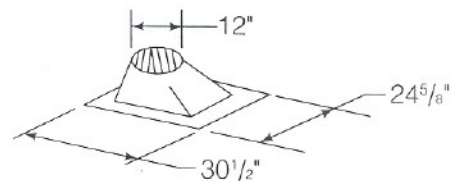

6/12 to 12/12 Pitch
RF371

CHIMNEY TERMINAL CAPS & TERMINATIONS

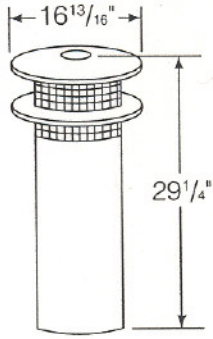

RT362
ROUND TERMINAL CAP

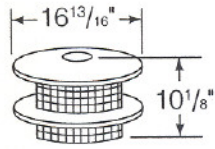

RT364 & RT364S
ROUND TERMINAL CAP
&
STAINLESS STEEL ROUND
TERMINAL CAP

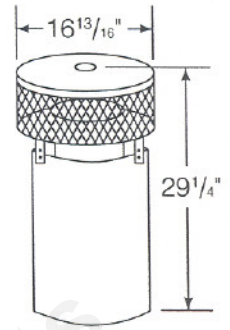

RT382
ROUND TERMINAL CAP

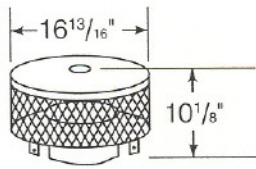

RT384
ROUND TERMINAL CAP

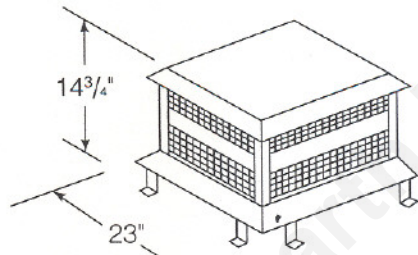

ST375
SQUARE TERMINAL CAP

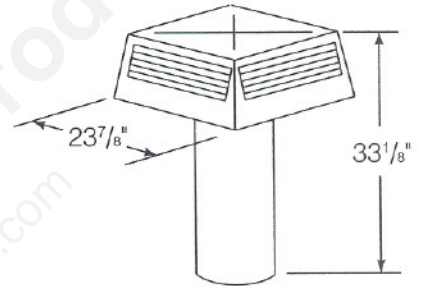

ST376
SQUARE TERMINAL CAP

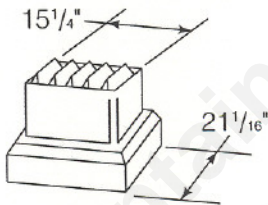

ST8
HOUSING TOP

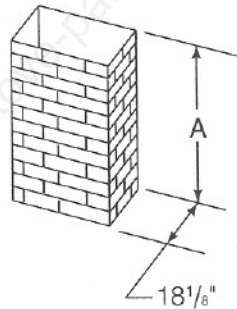

SIMULATED BRICK TERMINATIONS

CAT. NO.	A
RB4	45 ³ / ₄ "
TB4	45 ³ / ₄ "
RB6	69 ³ / ₄ "
TB6	69 ³ / ₄ "

CHASE TOP

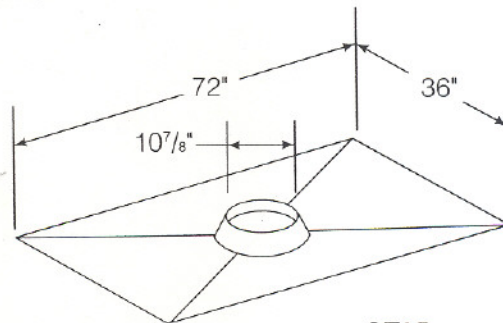

CT35

III. FIREPLACE LOCATIONS, SPACE AND CONSTRUCTION REQUIREMENTS

The fireplace may be located as shown in Figure 1.

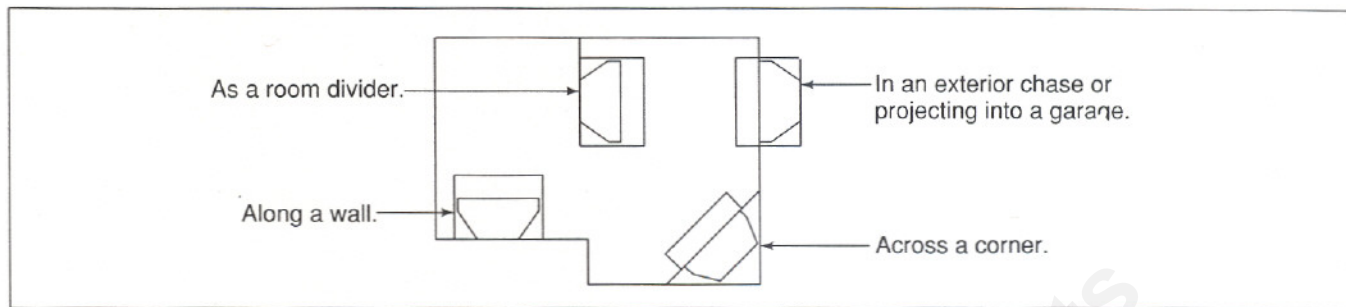

Figure 1
Fireplace Locations

Figures 2 and 3 show installations assuming outside air ducts with allowance for making 90° bends. Less space is required when ducting goes directly outside without forming elbows.

Figure 2
Installation along a wall or an exterior chase.

WITHOUT OUTSIDE AIR

CAT. NO.	A
NA36AI	41 ¹ / ₈
NA42AI	47 ¹ / ₈

WITH OUTSIDE AIR

CAT. NO.	A
NA36AI	45 ³ / ₁₆
NA42AI	51 ³ / ₁₆

Figure 3
Corner Installation

WITH OR WITHOUT OUTSIDE AIR

CAT. NO.	A	B	C	D	E	F
NA36AI	41 ¹ / ₈	72 ¹ / ₈	36 ¹ / ₁₆	15 ¹⁵ / ₁₆	15 ¹⁵ / ₁₆	51
NA42AI	47 ¹ / ₈	78 ¹ / ₈	39 ¹ / ₁₆	18 ¹ / ₁₆	18 ¹ / ₁₆	55 ¹ / ₄

ALL DIMENSIONS IN INCHES

WARNING

WHEN LOCATING THE FIREPLACE IN A SPACE PROJECTING INTO A GARAGE, THE OUTSIDE AIR MUST NOT BE TAKEN FROM THE GARAGE SPACE. EXHAUST PRODUCTS OF GASOLINE ENGINES ARE HAZARDOUS.

DO NOT INSTALL OUTSIDE AIR DUCTS SUCH THAT THE AIR MAY BE DRAWN FROM ATTIC SPACES, BASEMENTS, OR ABOVE THE ROOFING WHERE OTHER HEATING APPLIANCES OR FANS AND CHIMNEYS EXHAUST OR UTILIZE AIR. THESE PRECAUTIONS WILL REDUCE THE POSSIBILITY FOR SMOKING OR FLOW REVERSAL.

Figure 4 shows a typical framing of the fireplace, assuming combustible materials are used. All required clearances to combustibles around the fireplace must be adhered to. Any enclosure on top of the fireplace must be above the top standoffs. Chimney Sections at any level require a minimum air space of two inches to the enclosure, including any framing, for the total chimney height.

WARNING

TO PREVENT CONTACT WITH SAGGING OR LOOSE INSULATION, THE FIREPLACE MUST NOT BE INSTALLED AGAINST VAPOR BARRIERS OR EXPOSED INSULATION. LOCALIZED OVERHEATING COULD OCCUR AND A FIRE COULD RESULT.

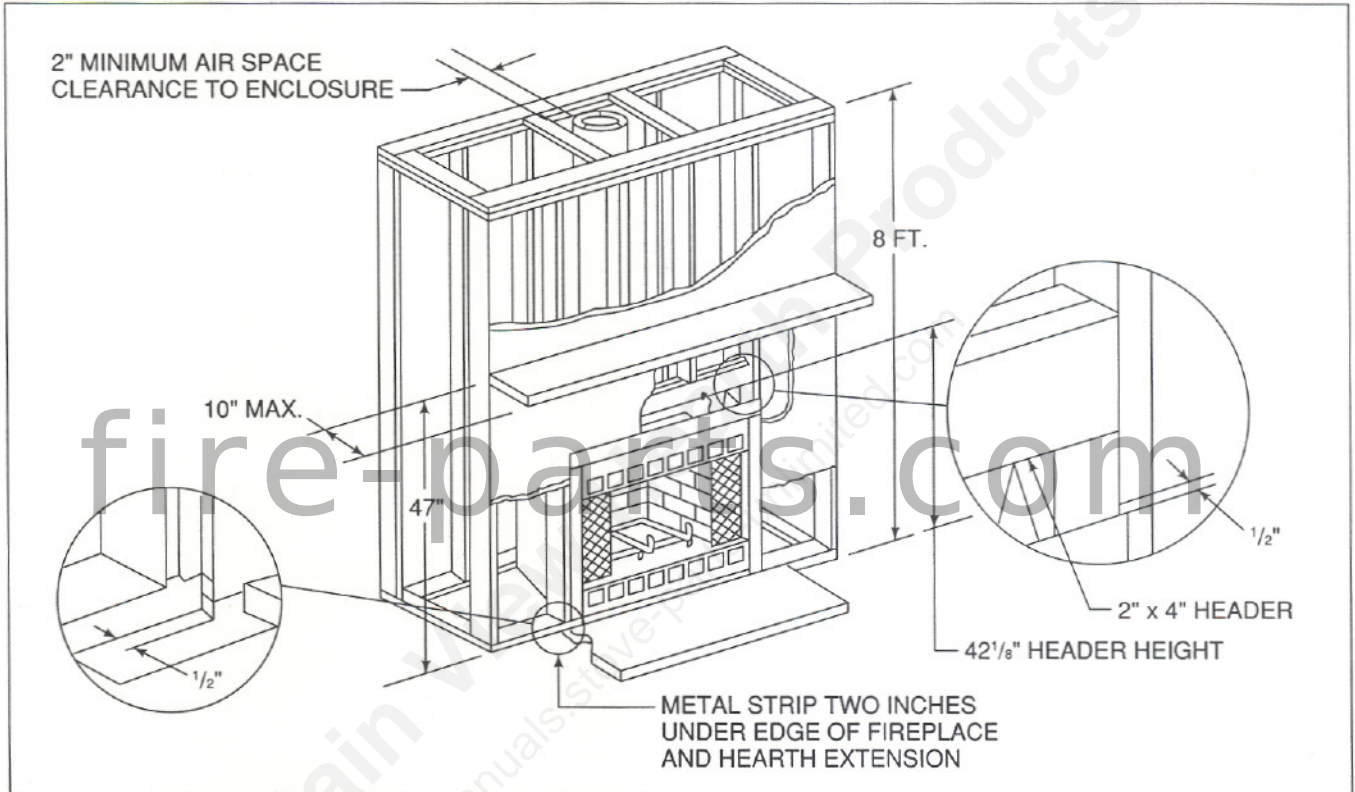

Figure 4
Framing the Fireplace

After completing the framing and after applying the facing material over the framing, a non-combustible sealant, one-half inch wide maximum, must be used to close off any gaps at the top and sides between the fireplace and facing, to prevent cold air leaks.

WARNING

DO NOT APPLY FINISH MATERIALS OVER THE LOUVERED FACE OF THESE FIREPLACES. THIS WILL BLOCK THE FLOW OF COOLING AIR AND MAY CAUSE DANGEROUSLY HIGH TEMPERATURES ON COMBUSTIBLE SURFACES OR ON THE FIREPLACE ITSELF.

Non-combustible materials may be used to cover the black non-louvered fireplace front, but must not restrict the air flow to or from the front of the unit in any manner. The following is a description of materials specified in these Instructions:

Combustible Material. Material made of or surfaced with wood, compressed paper, plant fibers, plastics, or other material that will ignite and burn, whether flameproofed or not, or whether plastered or unplastered.

Non-combustible Material. Material which will not ignite and burn, such materials consisting entirely of steel, iron, brick, tile, concrete, slate, asbestos, glass or plasters, or combination thereof.

Non-combustible Sealant Material. General Electric RTV103 (Black), or equivalent. Rutland, Inc. Fireplace Mortar #63, or equivalent.

HEARTH EXTENSIONS

The use of factory-built Hearth Extensions is shown in Figure 5. These may be covered with a non-combustible decorative material with a maximum thickness of 3 5/16 inches. Seal gaps with non-combustible (sand-cement) grout or sealant.

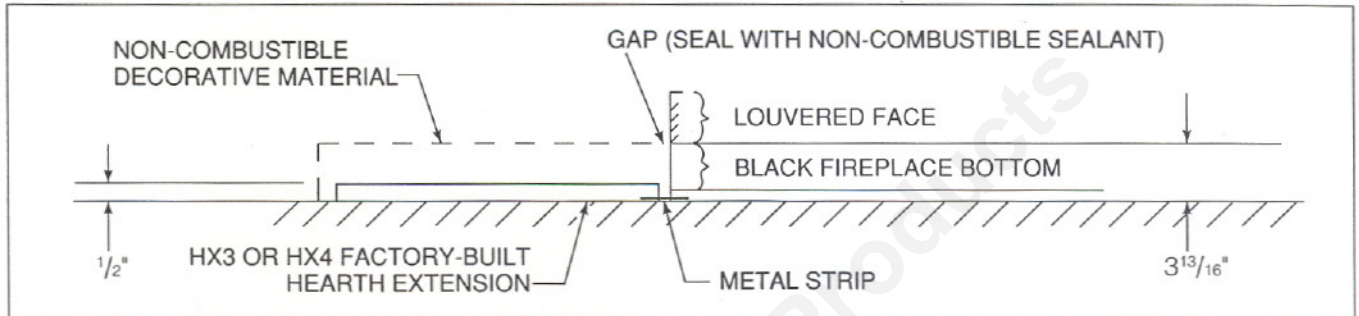

Figure 5
Factory-Built Hearth Extension

Field constructed Hearth Extensions may be used, but must be constructed in accordance with the following instructions. A typical construction is shown in Figures 6 and 7. In all cases of field construction, a minimum dimension of 16" to the front and extending 8" on either side of the fireplace opening must be used on the NA36AI, and gaps must be sealed with non-combustible (sand-cement) grout or sealant. A minimum of 20" to the front and 12" to either side of the opening must be maintained for the NA42AI fireplace.

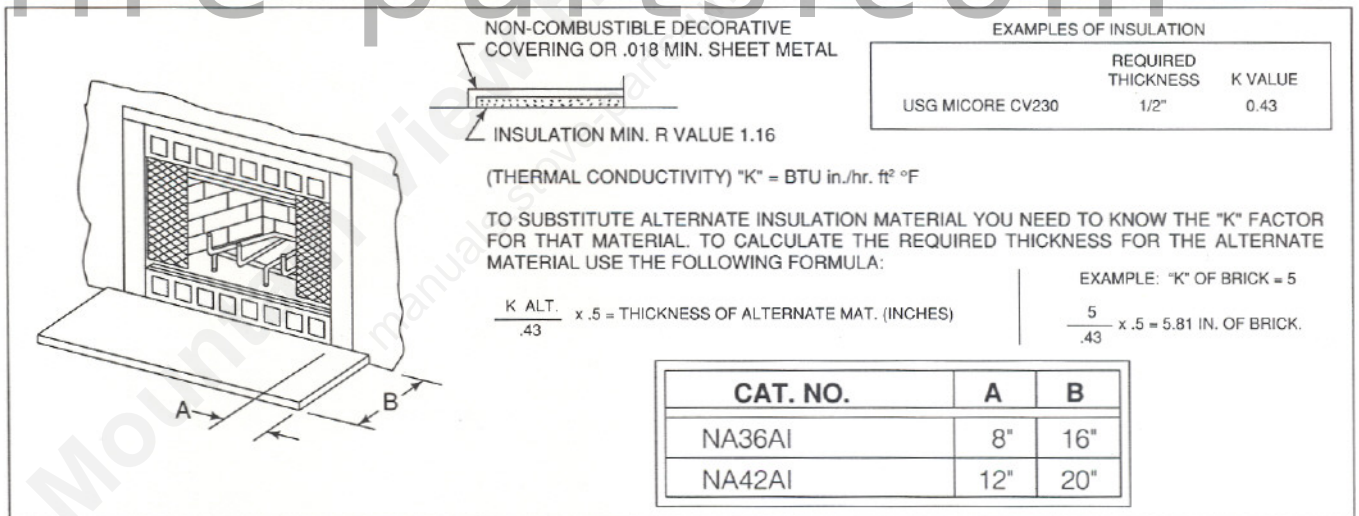

Figure 6

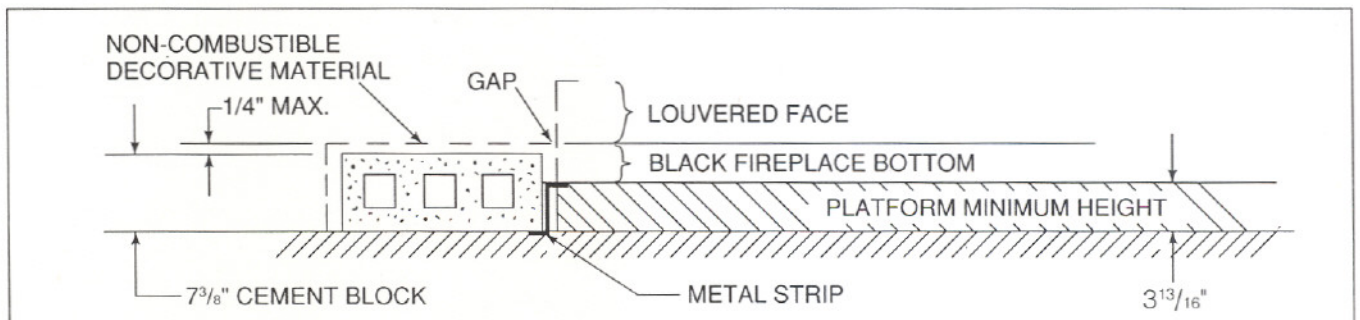



Figure 7
Field Constructed Hearth Extension

A second alternative to the cement block construction shown in Figure 7 is as follows:

1. One course common brick on edge - top layer.
2. 3/8" minimum millboard - middle.
3. Standard combustible construction - base.

Both Figure 7, and the above construction, require that the fireplace be raised on a platform. A metal strip must be used between the fireplace and the field constructed Hearth Extension. Depending on the construction, a special () shape may be needed. Each horizontal leg must be 2" wide and the length must be at least equal to the length of the Metal Strip provided with each fireplace. The fireplace must rest on a continuous, level surface.

WARNING

HEARTH EXTENSIONS ARE TO BE INSTALLED ONLY AS ILLUSTRATED TO PREVENT HIGH TEMPERATURES FROM OCCURRING ON CONCEALED COMBUSTIBLE MATERIALS. METAL STRIPS PREVENT BURNING OR HOT PARTICLES FROM INADVERTENTLY FALLING DIRECTLY ON COMBUSTIBLE SURFACES IN THE EVENT THE BUILDING SHOULD SETTLE AND DISTURB THE ORIGINAL CONSTRUCTION.

SIDEWALLS/SURROUNDS

Adjacent combustible side walls must be located a minimum of 18" from the fireplace opening. See Figure 8. If using a decorative surround of combustible material, it must be located within the shaded angle area defined in Figure 8. Short stub walls are also acceptable if they are contained in the shaded area.

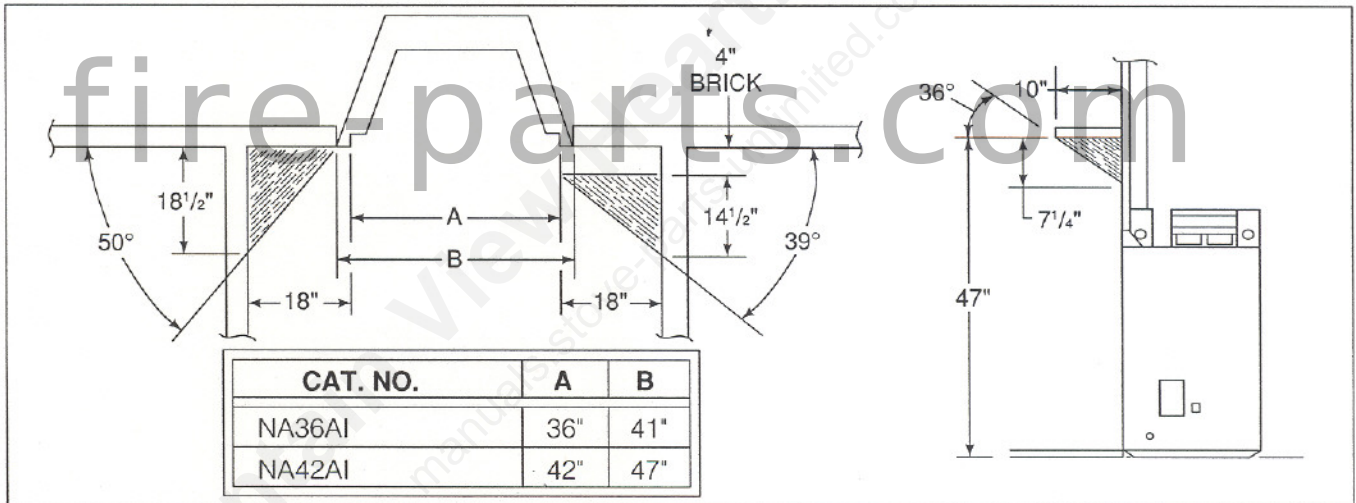

Figure 8

MANTEL

A mantel of combustible material may be installed no less than 47" above the platform or floor upon which the fireplace is located. The mantel may extend no more than 10" from the wall. Decorative combustible materials, such as a surround or mantel support brackets may be located within the shaded area defined in Figure 8. Mantels of depths less than 10" can be located at lower heights if the entire mantel is contained within the shaded area.

IV. CHIMNEY REQUIREMENTS

When planning your fireplace location, the chimney construction and necessary clearance must be considered. The fireplace system and chimney components have been tested to provide the following flexibility in construction.

- | | |
|---|----------|
| Minimum straight height | 13 ft. |
| Minimum height with Offset/Return | 14.5 ft. |
| Maximum height | 90 ft. |
| Maximum chimney length between an Offset/Return | 8 ft. |
| Maximum distance between Chimney Stabilizers | 35 ft. |
| Double Offset/Return minimum height | 20 ft. |
| Maximum unsupported chimney length between Offset/Return | 6 ft. |
| Maximum straight unsupported chimney height above firebox | 25 ft. |

OFFSET INSTALLATIONS

To clear any overhead obstructions, the chimney may be offset using a 15° Offset/Return, Catalog Number SL315, or a 30° Offset/Return, Catalog Number SL330. Figure 9 and Table 1 enable selection of the appropriate chimney components when using Offsets and Returns.

1. Determine amount of offset required to extend the chimney through a wall or around an obstacle. See Figure 9, dimension "A".
2. Refer to Table 1 and find the "A" dimension closest to but not less than the amount of offset required in your installation.

WARNING

DO NOT COMBINE OFFSETS TO CREATE AN OFFSET GREATER THAN 30° FROM VERTICAL. THIS MAY CREATE A FIRE HAZARD SINCE THE NATURAL DRAFT MAY BE RESTRICTED.

3. Find the "B" dimension in Table 1 and determine if it is compatible with your installation.
4. Read across the chart and find the Catalog Number and number of Chimney Sections required.
5. Refer to Section V, Step-By-Step Installation of the Fireplace System.
6. All joist areas must be Firestopped.

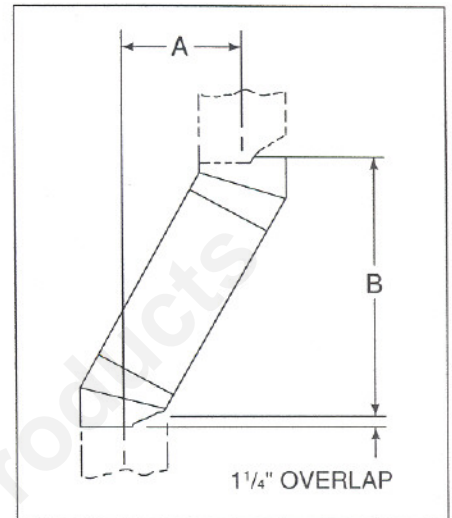

Figure 9
Chimney Offset/Return

TABLE 1

Offset Chart

(Dimensions in Inches)

15°		30°		SL306	SL312	SL318	SL324	SL336	SL348
A	B	A	B						
1 ⁵ / ₈	13 ³ / ₈	3 ⁷ / ₈	14 ⁷ / ₁₆	-	-	-	-	-	-
2 ⁷ / ₈	17 ³ / ₄	6 ¹ / ₄	18 ⁹ / ₁₆	1	-	-	-	-	-
-	-	8 ⁵ / ₈	22 ¹¹ / ₁₆	2	-	-	-	-	-
4 ⁷ / ₁₆	23 ⁹ / ₁₆	9 ¹ / ₄	23 ³ / ₄	-	1	-	-	-	-
-	-	11 ⁵ / ₈	27 ⁷ / ₈	1	1	-	-	-	-
6	29 ³ / ₈	12 ¹ / ₄	28 ¹⁵ / ₁₆	-	-	1	-	-	-
7 ³ / ₁₆	34	14 ⁵ / ₈	33 ¹ / ₁₆	-	2	-	-	-	-
-	-	15 ¹ / ₄	34 ¹ / ₈	-	-	-	1	-	-
-	-	17 ⁵ / ₈	38 ¹ / ₄	1	-	-	1	-	-
-	-	20 ⁵ / ₈	43 ⁷ / ₁₆	-	-	2	-	-	-
10 ⁵ / ₈	46 ³ / ₄	21 ¹ / ₄	44 ⁹ / ₁₆	-	-	-	-	1	-
11 ⁷ / ₈	51 ³ / ₈	23 ⁵ / ₈	48 ¹¹ / ₁₆	1	-	-	-	1	-
-	-	26 ⁵ / ₈	53 ¹³ / ₁₆	-	-	-	2	-	-
13 ³ / ₄	58 ³ / ₈	27 ¹ / ₄	55 ³ / ₄	-	-	-	-	-	1
15	62 ¹⁵ / ₁₆	29 ⁵ / ₈	59 ¹ / ₁₆	1	-	-	-	-	1
16 ¹ / ₂	68 ³ / ₄	32 ⁵ / ₈	64 ¹ / ₄	-	1	-	-	-	1
18 ¹ / ₁₆	74 ⁹ / ₁₆	35 ⁵ / ₈	69 ⁷ / ₁₆	-	-	1	-	-	1
-	-	38 ⁵ / ₈	74 ⁵ / ₈	-	-	-	1	-	1
-	-	41	78 ³ / ₄	1	-	-	1	-	1
22 ³ / ₄	91 ⁷ / ₈	44 ⁵ / ₈	85 ¹ / ₁₆	-	-	-	-	1	1
24	96 ¹ / ₂	47	89 ¹ / ₈	1	-	-	-	1	1
25 ⁷ / ₈	103 ¹ / ₂	50 ⁵ / ₈	95 ⁷ / ₁₆	-	-	-	-	-	2

Figure 10 illustrates the height from the bottom of the fireplace to the top of the Chimney Starter Section. Proper assembly of Air Cooled Chimney Sections results in an overlap at chimney joints of 1 1/4".

Major building codes specify a minimum chimney height above the roof top. These specifications are summarized in what is known as the "Ten Foot Rule". This rule states:

1. If the horizontal distance from the side of the chimney to the peak of the roof is 10 feet or less, the top of the chimney must be at least 2 feet above the peak of the roof, but never less than 3 feet in height above the highest point where it passes through the roof. See Figure 11.
2. If the horizontal distance from the side of the chimney to the peak of the roof is more than 10 feet, a chimney height reference point is established on the surface of the roof a distance of 10 feet from the side of the chimney in a horizontal plane. The top of the chimney must be at least 2 feet above this reference point, but never less than 3 feet in height above the highest point where it passes through the roof. See Figure 12.

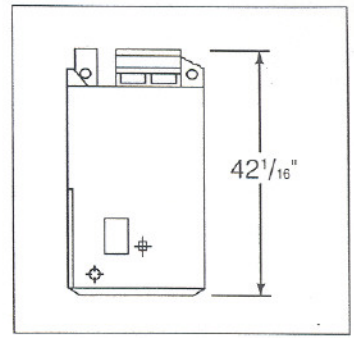

Figure 10
Fireplace (Side View)

These chimney heights are necessary in the interest of safety and do not assure smoke-free operation. Trees, buildings, adjoining roof lines, adverse wind conditions, etc., may require a taller chimney should smoking occur.

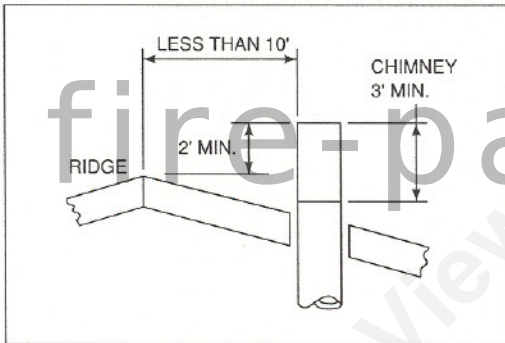

Figure 11
Chimney Height

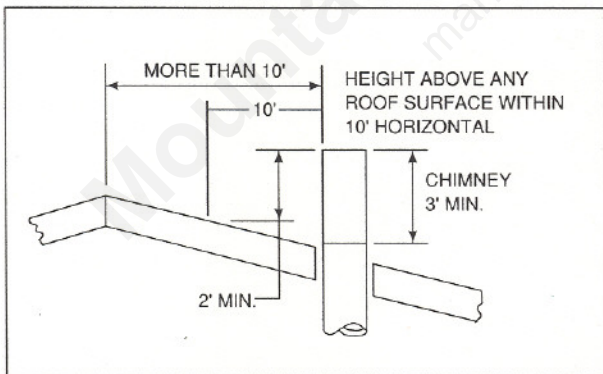

Figure 12
Chimney Height

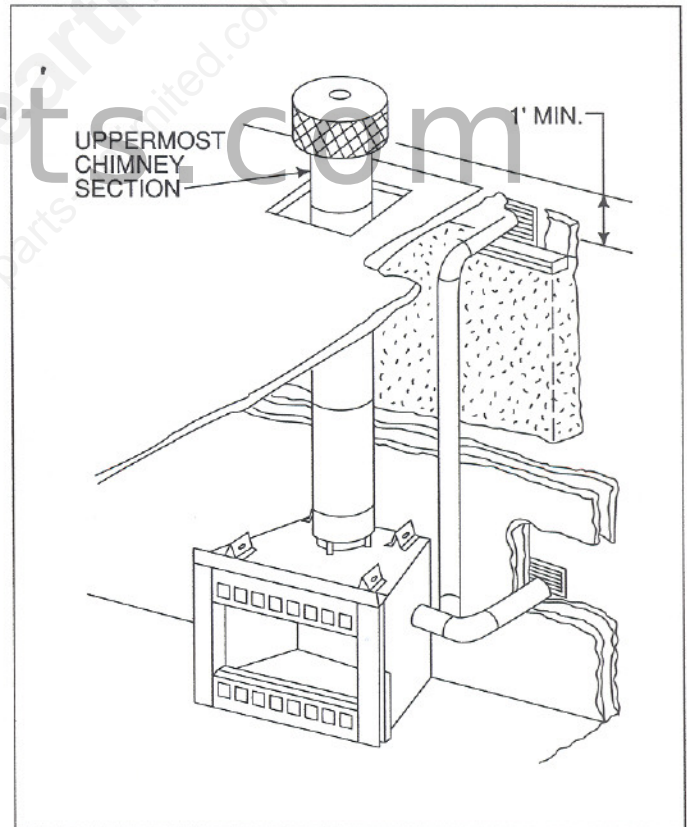

Figure 13
Outside Air Location

If Outside Combustion Air is used, Figure 13 illustrates only two of many possible locations - a basement fireplace with a vertical outside air arrangement; and a horizontal, direct exit from the fireplace side.

NOTE: A 1' minimum height difference must be maintained from the top of the uppermost Chimney Section to the Outside Combustion Air inlet.

V. STEP-BY-STEP INSTALLATION OF THE FIREPLACE SYSTEM

WARNING

BEFORE STARTING, DO THE FOLLOWING:

- 1. WEAR GLOVES AND SAFETY GLASSES FOR PROTECTION.**
- 2. KEEP HAND TOOLS IN GOOD CONDITION. SHARPEN CUTTING EDGES AND MAKE SURE TOOL HANDLES ARE SECURE.**
- 3. ALWAYS MAINTAIN THE MINIMUM AIR SPACE REQUIRED TO THE ENCLOSURE TO PREVENT FIRE.**

STEP 1

Position the fireplace in the desired location and frame.

STEP 2

Slide the metal strip two inches under the front edge of the fireplace. See Figure 4. When the metal strip is not provided as a single piece, then the individual pieces must overlap each other by one inch.

STEP 3

Level the fireplace side-to-side and front-to-back. Shim with non-combustible material as necessary. Secure the fireplace by utilizing the nailing flanges located on either side of the fireplace.

WARNING

CAREFULLY FOLLOW THE INSTRUCTIONS FOR ASSEMBLY OF THE PIPE AND OTHER PARTS NEEDED TO INSTALL THIS FIREPLACE SYSTEM. FAILURE TO DO SO MAY RESULT IN A FIRE, ESPECIALLY IF COMBUSTIBLES ARE TOO CLOSE TO THE FIREPLACE OR CHIMNEY AND AIR SPACES ARE BLOCKED PREVENTING THE FREE MOVEMENT OF COOLING AIR.

STEP 4

Assemble either a straight Pipe Section or an Offset to the top of the fireplace. Chimney Sections are locked together by pushing downward until the section meets the stop bead on the section below. When using Offset/Returns, the Offset and Return sections should be secured in place with screws to insure proper orientation. See Figure 14.

CAUTION

INNER FLUE AND OUTER LINER SECTIONS CANNOT BE DISASSEMBLED ONCE LOCKED TOGETHER. PLAN AHEAD TO INSURE PROPER INSTALLATION HEIGHT IS ACHIEVED WITH THE SELECTED CHIMNEY COMPONENTS.

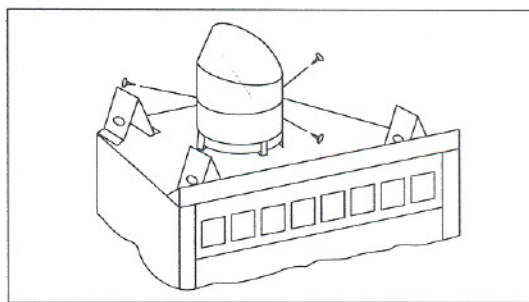
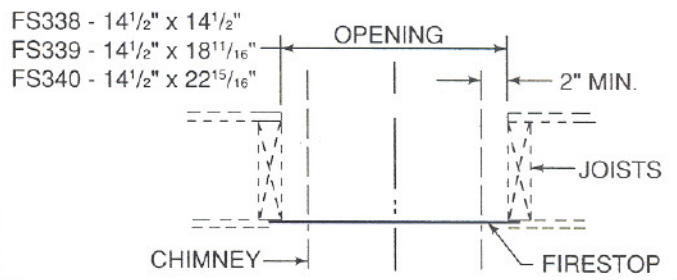

Figure 14

Offset Secured to Fireplace

STEP 5

Mark and cut out an opening in the ceiling for the particular Firestop Spacer being utilized ($14\frac{1}{2}$ " x $14\frac{1}{2}$ " for an FS338, $14\frac{1}{2}$ " x $18\frac{11}{16}$ " for an FS339, or $14\frac{1}{2}$ " x $22\frac{15}{16}$ " for an FS340). Frame the opening with the same size lumber used in the ceiling joists. See Chapter 25 of the Uniform Building Code for general construction requirements when "Framing Around Openings".



□ STEP 6

Install the Firestop Spacer FS338 (Straight), FS339 or FS340 (15° or 30° Offset, if Offset is located in the ceiling joist area). Nail the four sides of the Firestop to the joists using a minimum of (3) nails per side. These Firestop Spacers are designed to provide the minimum two inch air space around the chimney. In all situations, the Firestops are to be nailed to the ceiling joists from the bottom or fireplace side, EXCEPT, when the space above the ceiling is an attic space. In this situation, the Firestop must be nailed from the attic side to ensure against loose or later blow-in-type insulation from falling into the required two inch air space around the chimney. Firestop Spacers must be used at all ceiling levels where the chimney penetrates a living space.

NOTE: Nails must always be driven so the nail head is in shear (shank is perpendicular to the chimney load). This will prevent the nail from pulling loose.

□ STEP 7

Continue assembling Chimney Sections up through the Firestop Spacers as needed. Check height and unsupported chimney length limitations described earlier.

The maximum straight unsupported height is 25 feet above the firebox and 35 feet between Chimney Stabilizers (SL3).

□ STEP 8

When Offsets/Returns are joined to straight Pipe Sections, they must be locked in position with the size 10 sheet metal screws provided, using the predrilled holes. Offsets/Returns and Chimney Stabilizers have straps for securing these parts to joists or rafters. Plumbers tape may be purchased locally and used in conjunction with Joint Bands to secure the chimney as an alternate method. Chimney Brackets may be used to stabilize the chimney. See Figures 15 and 16.

NOTE: Be sure to provide intermediate support for the pipe during construction and check to be sure inadvertent loading has not dislodged the Pipe from the fireplace or at any chimney joint.

fire-parts.com

Figure 15
Chimney with Stabilizer

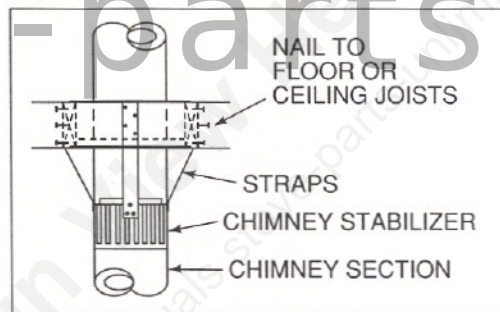

Figure 16
Offset/Return Installation

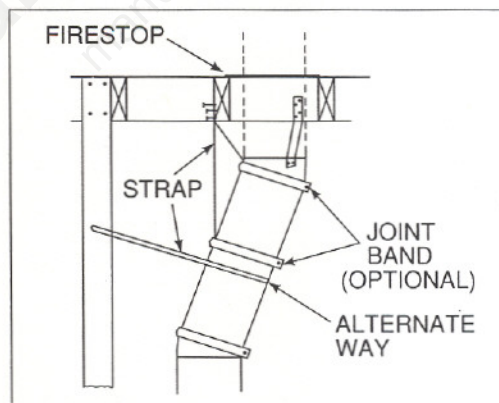
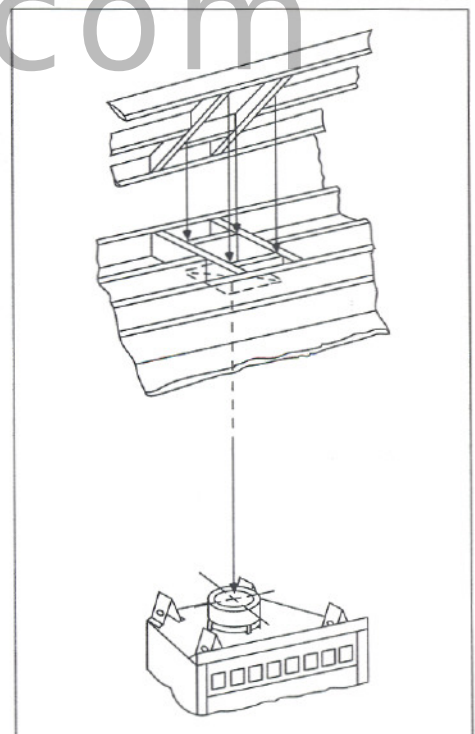

Figure 17
Ceiling and Attic Construction



WARNING

WHEN CHIMNEY SECTIONS EXCEEDING 6 FEET IN LENGTH ARE INSTALLED BETWEEN AN OFFSET/RETURN, STRUCTURAL SUPPORT MUST BE PROVIDED TO REDUCE OFF-CENTER LOADING AND PREVENT CHIMNEY SECTIONS FROM SEPARATING AT THE CHIMNEY JOINTS.

STEP 9

Locate the point where the chimney will exit the roof by plumbing down to the center of the chimney. Drive a nail through the roof to mark the center. See Figure 17.

STEP 10

Measure to either side of the nail and mark the 14 1/2" x 14 1/2" opening required. This 14 1/2" x 14 1/2" is measured on the horizontal; actual length may be larger depending on the pitch of the roof. Cut out and frame the opening. See Chapter 25 of the Uniform Building Code for Roof Framing details.

STEP 11

Continue to add Chimney Sections through the roof opening, maintaining at least a 2" air space.

STEP 12

Install the Roof Flashing appropriate to the roof pitch and install one of these Terminal Caps: RT362 or RT382 (Telescoping-Round), RT364 or RT384 (Round), or RT364S (Stainless Steel-Round) following the Instructions shipped with these accessories. The Terminal Cap may also be a ST8 (Housing Top and Flashing) utilizing RB4, TB4, RB6 or TB6 (Simulated Brick Panels) and installed in accordance with the Instructions shipped with these accessories. For flat roof pitch installations, Terminal Caps ST375 (Square) or ST376 (Telescoping-Square) may be installed utilizing a Chase Top.

WARNING

DETAIL INSTRUCTIONS FOR INSTALLATION OF THE ROOF FLASHING, STORM COLLAR AND TERMINAL CAP ARE FOUND PACKAGED WITH THESE PARTS. TO AVOID DANGER OF FIRE, ALL INSTRUCTIONS MUST BE STRICTLY FOLLOWED, INCLUDING THE PROVISION OF AIR SPACE CLEARANCE BETWEEN CHIMNEY SYSTEM AND COMBUSTIBLE ENCLOSURE. TO PROTECT AGAINST EFFECTS OF METAL CORROSION OF THE ABOVE PARTS, FIRST WASH THEM WITH A SOLVENT OR VINEGAR, RINSE WITH WATER, AND THEN PAINT WITH A RUST RESISTANT PAINT.

STEP 13

Complete the fireplace enclosure, allowing space for outside air ducts and gas piping if desired. Care must be taken with any electrical wiring to avoid exposure to high temperatures or mechanical damage to wire insulation. A minimum clearance of 1/2" must be maintained between the fireplace sides and the combustible enclosure.

STEP 14

Knockouts are provided on both sides of the fireplace to allow for connection of a decorative gas appliance incorporating an automatic shutoff device and complying with the Standard for Decorative Gas Appliances for Installation in Vented Fireplaces, ANSI Z21.60. The decorative gas appliance should be installed in accordance with the National Fuel Code, ANSI Z223.1-1980. The side refractories are designed to allow 1/2" iron pipe to pass through. Use a non-combustible sealant to seal any opening between the gas pipe and refractory on the inside. Repack the insulation removed, to seal around the gas pipe where it exits the side of the fireplace.

CAUTION

- 1. WHEN USING THE DECORATIVE APPLIANCE, THE FIREPLACE DAMPER MUST BE SET IN THE FULLY OPEN POSITION.**
- 2. A FULLY OPEN DAMPER ENSURES PROPER VENTING OF COMBUSTION PRODUCTS.**

STEP 15

Install Outside Air if desired or required by local code, using the Instructions supplied with the AK14 Air Kit. The use of Outside Air is strongly recommended.

STEP 16

If a Fan Kit is desired, first complete installation of the Junction Box Kit (JK1), referring to the separate JK1 Instructions packaged with the fireplace. Fan Kits FK1 and/or FK2 can only be installed after the JK1 Junction Box Kit has been installed. Follow the Instructions supplied with the Fan Kits for proper installation. It is recommended to install the JK1 Junction Box Kit during initial construction even if fans are not initially desired - this allows for adding a Fan Kit at a later date.

WARNING

DISCONNECT POWER BEFORE STRIPPING OR JOINING ANY SUPPLY WIRES. ONLY PERSONS QUALIFIED FOR MAKING ELECTRICAL INSTALLATIONS (ELECTRICIANS) AS RECOGNIZED BY LOCAL OR NATIONAL GOVERNMENTAL BODIES SHOULD ATTEMPT TO MAKE THE INCOMING SUPPLY WIRE CONNECTIONS.

EDGES ARE SHARP. HAND PROTECTION IS RECOMMENDED. RECHECK ALL FASTENERS BEFORE LEAVING JOB.

NOTE: A Motor Speed Control Kit, Catalog Number BC10, is available for use with this Fan Kit. Refer to the instructions packed with it for proper installation. If a speed control option is desired, it is recommended to use the BC10 Kit to insure proper function.

STEP 17

Attach the firescreen to the fireplace side, utilizing the (2) hair pin clips from the enclosed fastener package. Use pliers to insert the clip through the last strand of screen wire and into the hole at the midpoint of the fireplace side.

STEP 18

Install Glass Doors if desired, using the Instructions supplied with these optional accessories. Protect Glass Doors from breakage by temporarily removing them until all construction is complete.

STEP 19

Position the Hearth Extension over the metal protective strip which should project two inches in front of the fireplace bottom front. See Figure 4. Seal the crack between the Hearth Extension and fireplace with a non-combustible (sand-cement) grout or sealant.

STEP 20

Apply the finish materials of your choice. Do not install combustible materials over the black face of the fireplace or louvered openings. You may use non-combustible material over the black - non-louvered - face of the fireplace. Refer to Figure 8 for combustible surround information.

STEP 21

This fireplace is equipped with a factory installed Integral Grate. In the event it becomes necessary to replace it, remove the bracket securing the top of the back refractory and remove the back refractory (it may be necessary to adjust the side refractories). Remove the old Grate and reposition your new Grate. Use only Catalog Number GR1 or GR2 Integral Grate for replacement.

STEP 22

Prior to building your first fire in your fireplace, please read the "Operating Instructions" section that follows.

WARNING

DO NOT PACK REQUIRED AIR SPACES WITH INSULATION OR OTHER MATERIALS. THIS PREVENTS THE NATURAL CONVECTION COOLING WHICH MUST TAKE PLACE. THE REQUIRED CLEARANCES ARE TO THE ENCLOSURE AND SHOULD NOT BE REDUCED BY THE ADDITION OF OTHER MATERIALS WHETHER OF NON-COMBUSTIBLE OR COMBUSTIBLE MATERIAL. COMBUSTIBLE MATERIALS AS WELL AS THE NON-COMBUSTIBLE MATERIALS USED IN THE FIREPLACE MAY HAVE THEIR USEFUL LIFE REDUCED.

VI. CONSTRUCTING A CHASE

The chase may be constructed for the fireplace and chimney or for the chimney only. A chase is an enclosure built around the system. It is most commonly constructed on an outside wall as shown.

Three examples of chase applications are shown in Figure 18.

1. Fireplace and chimney enclosed in chase - exterior.
2. Chimney offset through exterior wall and enclosed in chase.
3. Chase constructed on roof.

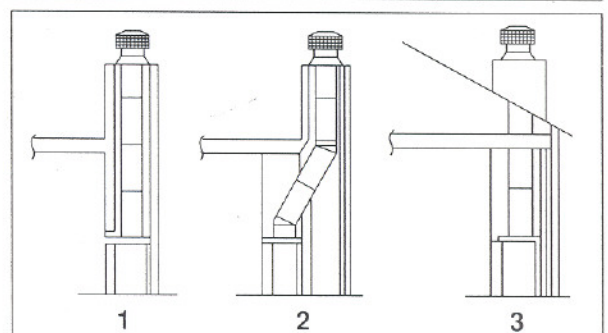

Figure 18

Chase Construction

MATERIALS FOR CHASE

The chase is constructed much the same as the walls in your home. A variety of materials may be used including brick, stone, veneer brick, or standard siding materials.

In constructing the chase, several factors must be considered.

1. Maintain a 2" air space clearance around the chimney.
2. The Chase Top must be constructed of a non-combustible material.
3. The walls of the chase must be insulated to prevent heat leaking from the home around and through the fireplace.

TO INSTALL TERMINAL CAP ON CHASE - ENCLOSED CHIMNEY

1. Construct chase of desired materials maintaining a minimum 2" air space around the chimney.

WARNING

NEVER INSTALL A SINGLE WALL SLIP SECTION OR SMOKE-PIPE IN A CHASE STRUCTURE. THE HIGHER TEMPERATURE OF THIS SINGLE WALL PIPE MAY RADIATE SUFFICIENT HEAT TO COMBUSTIBLE CHASE CONSTRUCTION MATERIALS TO CAUSE A FIRE.

2. Install the Chimney Sections up through the chase. When using a Round Terminal Cap (RT364, RT364S or RT384), the last section of Pipe must extend above the Chase Top to allow installation of the Storm Collar and Terminal Cap. For installations utilizing a Telescoping Round Terminal Cap (RT362 or RT382) or Telescoping Square Terminal Cap (ST376), the last Chimney Section must be below the top of the Chase Top, but not more than 18" below the Chase Top. For installations utilizing a Square Terminal Cap (ST375), the last Chimney Section must not be more than 4³/₄" below the base of the Chase Top. See Figure 19.

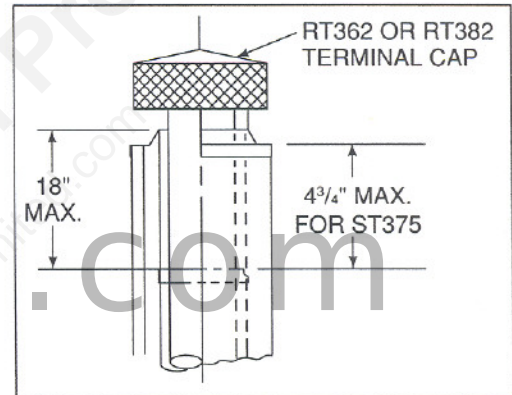

Figure 19

WARNING

DETAIL INSTRUCTIONS FOR INSTALLATION OF THE CHASE TOP, STORM COLLAR AND TERMINAL CAP ARE FOUND PACKAGED WITH THESE PARTS. TO AVOID DANGER OF FIRE, ALL INSTRUCTIONS MUST BE STRICTLY FOLLOWED, INCLUDING THE PROVISION OF AIR SPACE CLEARANCE BETWEEN CHIMNEY SYSTEM AND COMBUSTIBLE ENCLOSURE. TO PROTECT AGAINST EFFECTS OF METAL CORROSION OF PARTS SUCH AS CHASE TOP AND THOSE ABOVE CHASE TOP, FIRST WASH THEM WITH A SOLVENT OR VINEGAR, RINSE WITH WATER, AND THEN PAINT WITH A RUST RESISTANT PAINT.

3. Attach the Chase Top (CT35) to the top of the chase.
4. Install the Terminal Cap, using the Instructions packaged with it.

OPERATING INSTRUCTIONS

NOTICE

SAVE AND PASS THESE OPERATING INSTRUCTIONS AND THE INSTALLATION INSTRUCTIONS TO SUBSEQUENT OWNERS. THE INFORMATION PROVIDED IS INTENDED TO NOTIFY AND WARN THEM ABOUT MAKING UNSAFE FUTURE MODIFICATIONS SUCH AS THE ADDITION OF SHELVES OR THE USE OF UNAUTHORIZED PARTS AND REPAIRS.

CAUTION
EDGES ARE SHARP. HAND PROTECTION IS RECOMMENDED.

Before starting a fire in your new or existing fireplace, use the following check list:

- A. **FLUE DAMPER.** The flue damper is operated by moving the handle to the right, which should place the damper in the full open position. Verify by looking up from the inside of the firebox. Always operate this fireplace with the damper fully open. Please note, downdrafts, obstructions, damaged or poor (wet) fuels can cause smoke spillage.

WARNING

DO NOT OPERATE THE FIREPLACE WITH THE DAMPER RESTRICTED OR PARTIALLY CLOSED. THIS CAN RESULT IN SEVERE OVERTEMPERATURES AND POSSIBLE FIRE. THE FIREPLACE MUST BE OPERATED WITH THE DAMPER IN THE FULL OPEN POSITION.

- B. **CHIMNEY INSPECTION.** Visually inspect the chimney internally for obstructions and construction damage. Flue pipe joints and seams must be continuous and mechanically tight. In a used chimney, additional inspection is needed for the following:

"Creosote - Formation and Need for Removal.

When wood is burned slowly, it produces tar and other organic vapors, which combine with expelled moisture to form creosote. The creosote vapors condense in the relatively cool chimney flue of a slow-burning fire. As a result, creosote residue accumulates on the flue lining. When ignited, this creosote makes an extremely hot fire.

The chimney should be inspected at least twice a year during the heating season to determine if creosote build-up has occurred.

If creosote has accumulated, it should be removed to reduce the risk of a chimney fire."

- C. **CHIMNEY CLEANING.** If you do detect a build-up of creosote, contact a qualified chimney sweep or clean it yourself.

1. Open the damper.
 2. Hang a damp sheet across the fireplace opening to stop dirt and soot from entering the room.
 3. Remove the Terminal Cap or Housing Top. See Figure 20.
 4. Clean with a stiff bristled brush attached to a pole,
- OR,
- 4A. Tie a rope to a burlap bag filled with straw and several small stones or sand. Work up and down the flue until clean.
 5. Replace the Terminal Cap or Housing Top.

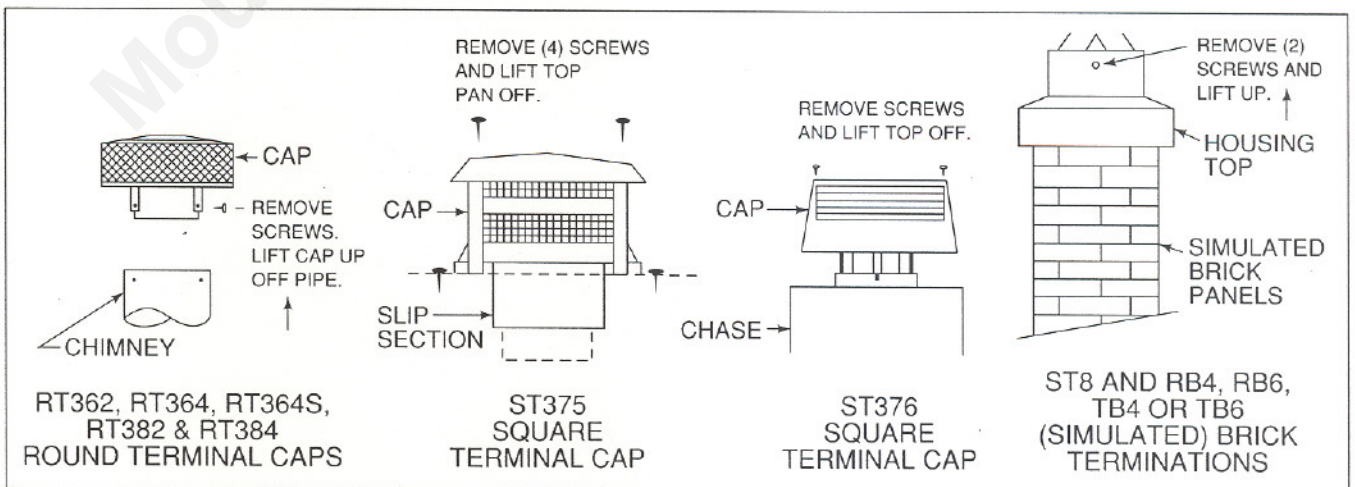

Figure 20
Terminal Caps

- D. **CLEAR SPACE NEAR FIREPLACE.** The Hearth Extension must extend at least 16 inches to the front and 8 inches on either side of the firebox opening for the NA36AI fireplace; and 20" to the front and 12" to the sides for the NA42AI fireplace. Combustible materials must not be stored in this area. Combustible walls perpendicular to the front of the fireplace must be at least 18 inches from the fireplace opening. Room furnishings such as drapes, curtains, chairs, or other combustibles must be at least 4 feet from the open front of the fireplace.

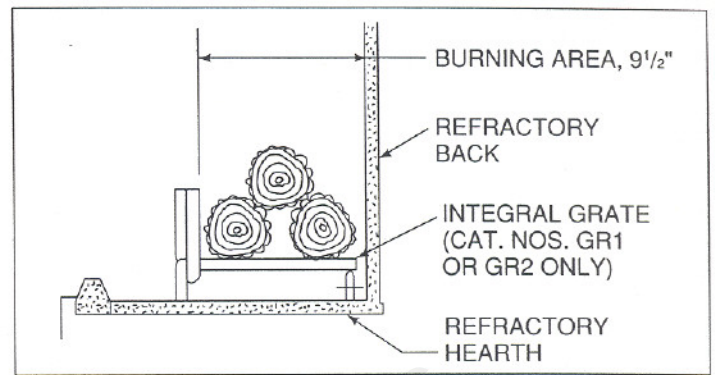

Figure 21
Section Through Fireplace

- E. **GRATE.** The factory installed Integral Grate must be used to hold the logs from falling out of an open fireplace and to allow air to pass between the burning logs. It is important to keep the fire off the hearth and to allow the ashes to collect beneath the fire, thereby forming a layer of additional heat protection. See Figure 21. Use only Catalog Number GR1 or GR2 Integral Grate for replacement.
- F. **FIRESCREEN.** A firescreen is always provided to control sparks. It must be closed whenever the fireplace is in use. Glass Doors or firescreens must not be used to hold burning material inside the fireplace as might occur when overfilling the fireplace with empty boxes or branches. Only those Glass Door units specifically tested and listed for use with the specific fireplace model should be used. Screens should be closed when the Glass Doors are closed.
- G. **OUTSIDE AIR.** A damper allows individual control of the Outside Air inlets if your fireplace is equipped with this option. In a tightly sealed or well insulated home, replacement of combustion air is necessary to keep harmful gases from entering living spaces.

CAUTION

FIREPLACE OPERATION DOES REQUIRE AIR. DO NOT TAKE AIR FROM OTHER FUEL BURNING APPLIANCES WHICH CAN RESULT IN IMPROPER VENTING (SMOKING) OR AIR DILUTION. ALWAYS PROVIDE ADEQUATE MAKE-UP AIR.

- H. **SETTING THE FIRE.** Check the flue damper to be sure it is fully open. Place crumpled or twisted paper under the Grate. Loosely arrange kindling or small pieces of wood to form a layer above the paper. Place three logs in a rough pyramid as shown in Figure 21, being sure to allow free air space between the logs. Small sticks of wood may be used to separate the logs. Use only solid wood fuel or a listed decorative gas appliance. Do not use a fireplace insert or other products not specified for use with this fireplace. **NOTE: When heated the first time, the temperature of the fireplace must be raised gradually, to prevent moisture within the refractory from causing cracks, and to allow the binders in the insulation to dissipate.**

CAUTION

NEVER USE GASOLINE, GASOLINE-TYPE LANTERN FUEL, KEROSENE, CHARCOAL LIGHTER FLUID, OR SIMILAR LIQUIDS TO START OR 'FRESHEN UP' A FIRE IN THIS FIREPLACE. KEEP ALL SUCH LIQUIDS WELL AWAY FROM THE FIREPLACE WHILE IT IS IN USE TO AVOID THE RISK OF FIRE.

- I. **DISPOSAL OF ASHES.** Ashes should be placed in a metal container with a tight-fitting lid. The closed container of ashes should be placed on a non-combustible floor or on the ground, well away from all combustible materials, pending final disposal. If the ashes are disposed of by burial in soil or otherwise locally dispersed, they should be retained in the closed container until all cinders have thoroughly cooled.

- J. **GLASS DOORS.** Most efficient fireplace operation using Glass Doors is with the Doors open. When the fireplace is not in use, Glass Doors will prevent loss of room heat through the chimney. Only HEATILATOR® Glass Doors, Catalog Numbers GD36A, GD36B, GA36A, GA36B, C1136A, C1136B, C1136C, C2136A, C2136B, C2136C, D1136B or D2136B may be used on the NA36AI. Glass Doors, Catalog Numbers GD42A, GD42B, C1142A, C1142B, C1142C, C2142A, C2142B, C2142C, D1142B or D2142B may be used on the NA42AI.

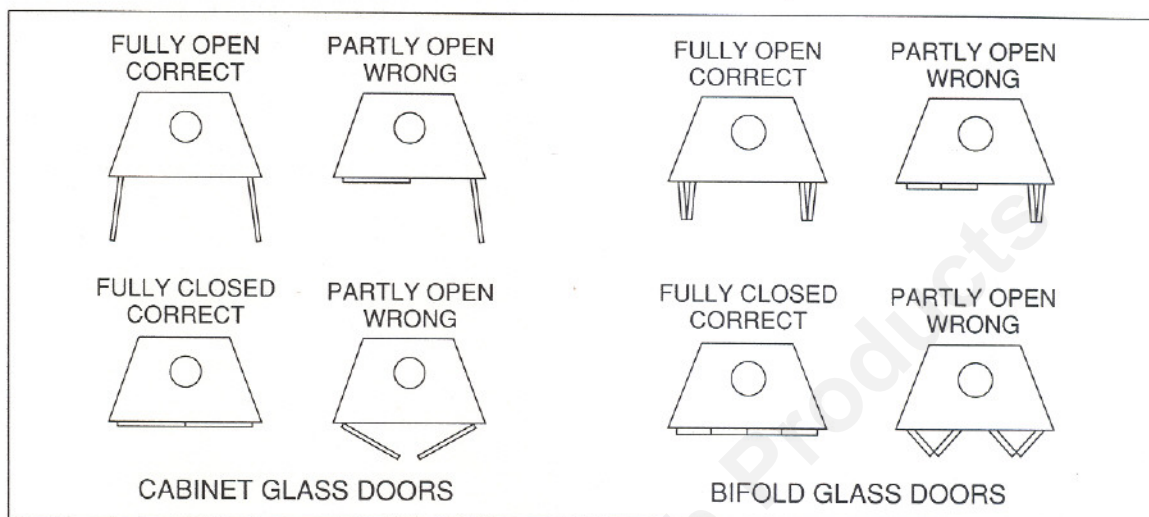

Figure 22
Recommended Operating Positions of Doors

WARNING

FIREPLACES EQUIPPED WITH DOORS SHOULD BE OPERATED ONLY WITH DOORS FULLY OPEN OR DOORS FULLY CLOSED. IF DOORS ARE LEFT PARTLY OPEN, GAS AND FLAME MAY BE DRAWN OUT OF THE FIREPLACE OPENING, CREATING RISKS OF BOTH FIRE AND SMOKE.

- K. **OPERATING YOUR FIREPLACE.**

WARNING

CONTINUED OVERFIRING CAN PERMANENTLY DAMAGE YOUR FIREPLACE SYSTEM. EXAMPLES OF OVERFIRING ARE:

1. **QUANTITIES OF SCRAP LUMBER, PINE BRANCHES OR CARDBOARD BOXES WHICH EXCEED THE VOLUME OF THE "NORMAL LOG FIRE". THESE MATERIALS PRODUCE MANY SPARKS AND MUST NOT BE USED.**
2. **THE "NORMAL LOG FIRE" IS THREE LOGS, EACH FOUR INCHES IN DIAMETER, WITH THE LENGTH NO GREATER THAN THE BACK WALL OF THE FIREPLACE. THE RATE OF FIRING MUST NOT EXCEED THESE THREE LOGS PER HOUR.**

- L. **FAN KIT.** HEATILATOR® FK1 and FK2 Heat Circulating Fans may be used with this fireplace. An external ON/OFF switch must be provided, or a Motor Speed Control BC10, may be used. Using these fans will increase efficiency and heat output.

- M. **SAFETY - A FINAL WORD.** Fireplaces as well as other woodburning appliances have been used safely for many years. Our own experience is that most problems are caused by improper installation, fueling, and operating. All dimensions specified are minimum and increasing distances to combustibles decreases risk. Such common practices as surrounding the fireplace with loose fill insulation, and especially leaving the fire unattended, will increase the risk of fire. Additionally, an annual inspection of all fireplace systems should be performed, as like any appliance, minor repairs may be required to maintain the system in top operating condition.

Attention

FIREPLACE INSTALLER

*Please return these
Operating & Installation
Instructions to the
Firebox
for Consumer Use*

heatilator[®]
The first name in fireplaces

Heatilator Inc.
1915 W. Saunders Street
Mt. Pleasant, IA 52641
a HON INDUSTRIES company
319/385-9211 FAX 319/385-9225