



heatilator®

The first name in fireplaces

Heatilator
1915 W. Saunders Street
Mt. Pleasant, IA 52641
A Division of Hearth Technologies Inc.

TRADITIONAL T3600 WOODBURNING FIREPLACE INSTALLATION & OPERATING INSTRUCTIONS FOR RESIDENTIAL USE

fire-parts.com

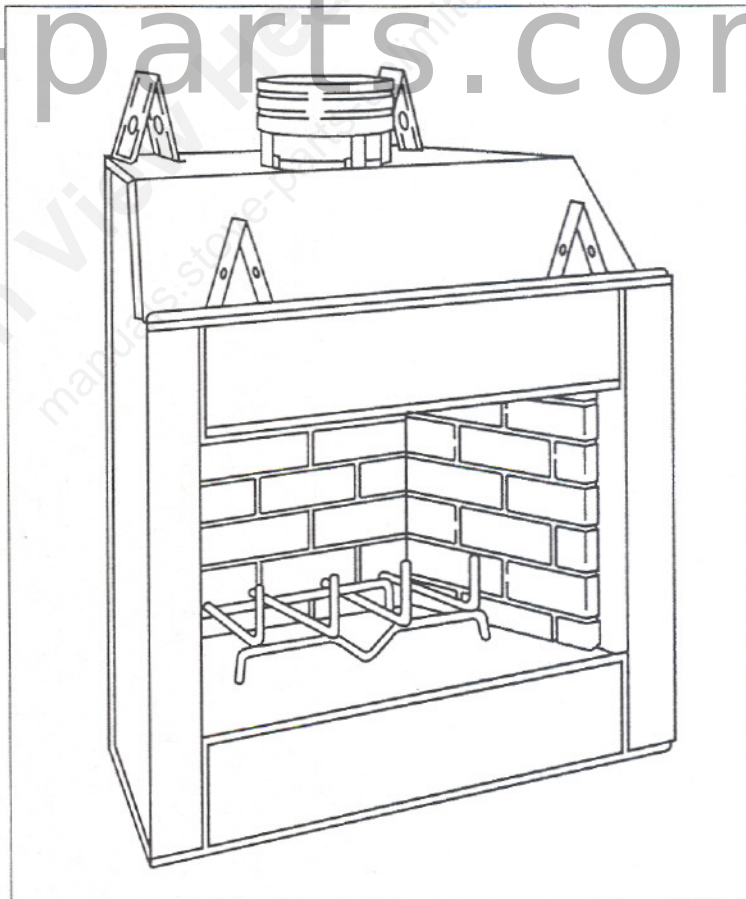

Plumber: Please refer to page 18 for gas connection information.



Framer: Please refer to page 9 for framing specifications.

PLEASE RETAIN THIS MANUAL FOR FUTURE REFERENCE.

Table of Contents

A. Listings and Code Approvals.....	3
B. Description of the Fireplace System.....	3
C. Fireplace System Components	4
D. Pre-Installation Preparation.....	8
1. Fireplace Locations and Space Requirements.....	8
2. Framing The Fireplace	9
3. Hearth Extensions	10
4. Sidewalls/Surrounds.....	11
5. Mantel.....	11
E. Chimney Requirements	11
1. Using Offsets and Returns	11
2. Chimney Height Requirements	13
3. Determining the Number of Chimney Sections Required.....	13
F. Step-By-Step Installation of the Fireplace System	14
G. Constructing a Chase.....	19
1. Materials For The Chase.....	19
2. Installing a Terminal Cap on a Chase-Enclosed Chimney.....	20
H. Operating Instructions	20

Safety Precautions:

1. Please read these installation instructions completely before beginning installation procedures. Failure to follow them could cause a fireplace malfunction resulting in serious injury and/or property damage.
2. Always check your Local Building Codes prior to installation. The installation must comply with all Local, Regional, State and National Codes and regulations.
3. An adequate supply of replacement combustion air from outside the house must be available to the fire for the fireplace to operate properly. To achieve this, an optional outside air kit is highly recommended.

In the event the home is unusually tight, the optional combustion air kit may not provide all the air required to support combustion. Heatilator is not responsible for any smoking or related problems that may result from the lack of adequate combustion air. It is the responsibility of the builder/contractor to ensure that adequate combustion air has been provided for the fireplace.
4. The T3600 woodburning fireplace must be installed with the Hearth Technologies Inc. (HTI) SL300 Series chimney system.

The chimney system must always terminate outside the building. Be sure to follow all chimney specifications given in these installation instructions.

5. **NEVER** leave children unattended when there is a fire burning in the fireplace.
6. This fireplace is built for solid fuel only. **NEVER** use gasoline, gasoline type lantern fuel, kerosene, charcoal lighter fluid, or similar liquids in this fireplace. Keep any flammable liquids a safe distance from the fireplace.
7. **DO NOT** use chimney cleaners or flame colorants in your fireplace.
8. The flue damper must be open at all times when the fireplace is in use.
9. While servicing this fireplace, always shut off any electricity or gas to the fireplace. This will prevent possible electrical shock or burns. Also, make sure the unit is completely cooled before servicing.
10. To ensure a safe fireplace system and to prevent the buildup of soot and creosote, inspect and clean the fireplace and chimney prior to use and periodically during the burning season.



A. LISTINGS AND CODE APPROVALS

The T3600 fireplace system has been tested and listed in accordance with UL 127 and ULC S610 Standards, and has been listed by Underwriters Laboratories Inc. for installation and operation in the United States and Canada as described in these Installation & Operating Instructions.

The model T3600 fireplace has been tested and listed for use with the components listed below. The optional components may be purchased separately and installed at a later date. However, installation of an outside air kit will require significant reconstruction, and should be installed at the time of the initial fireplace installation.

Check with your Local Building Code Agency prior to installing this fireplace to ensure compliance with local Codes, including the need for Permits and follow up inspections. If any assistance is required during installation, please contact your local dealer or the Heatilator Technical Services Department, 1915 W. Saunders Street, Mt. Pleasant, Iowa 52641.

Heatilator is a registered trademark of Heatilator, A Division of Hearth Technologies Inc.

WARNING!

THIS HEATILATOR FIREPLACE AND ITS COMPONENTS ARE DESIGNED TO BE INSTALLED AND OPERATED AS A SYSTEM. ANY ALTERATION TO OR SUBSTITUTION FOR ITEMS IN THIS SYSTEM, UNLESS ALLOWED BY THESE INSTALLATION INSTRUCTIONS, WILL VOID THE UNDERWRITERS LABORATORIES LISTING AND MAY VOID THE PRODUCT WARRANTY. IT MAY ALSO CREATE A HAZARDOUS INSTALLATION. READ THROUGH THESE INSTRUCTIONS THOROUGHLY BEFORE STARTING YOUR INSTALLATION AND FOLLOW THEM CAREFULLY THROUGHOUT YOUR PROJECT.

B. DESCRIPTION OF THE FIREPLACE SYSTEM

This Heatilator fireplace system consists of the following:

- | | |
|-----------------------------|---------------------|
| 1. Fireplace/Integral Grate | 3. Chimney System |
| 2. Chimney Termination Cap | 4. Hearth Extension |

Optional components include:

1. Glass Doors
2. Outside Combustion Air System

NOTE: Illustrations throughout these instructions reflect "typical installations" and are for design purposes only. Actual installation may vary slightly due to individual design preferences. However, minimum and maximum clearances must be maintained at all times.

The illustrations and diagrams used throughout these installation instructions are not drawn to scale.

Tools and Building Supplies Normally Required

Tools:

Saw
Pliers
Hammer
Phillips Screwdriver
Tape Measure
Plumb Line
Level
Electric Drill and Bits
Framing Square

Building Supplies:

Hearth Extension Material
Wall-finishing Materials
Framing Material
Fireplace Surround
Caulking Material



C. FIREPLACE SYSTEM COMPONENTS

The table below, together with the following pictures, show only those components which may be safely used with this fireplace.

HTI Cat.#	Description
T3600*	Fireplace, includes outside air kit, integral grate and hearth protection strips
HX3	Hearth Extension
DM1136	Original Bi-fold Glass Doors - Black Finish
DM1136A	Original Bi-fold Glass Doors - Polished Brass Finish
DM1136B	Original Bi-fold Glass Doors - Bright Brass Finish
C1136A	Classic Bi-fold Glass Doors - Brushed Brass Finish
C1136B	Classic Bi-fold Glass Doors - Polished Brass Finish
C1136C	Classic Bi-fold Glass Doors - Chrome Finish
C2136A	Classic Cabinet Glass Doors - Brushed Brass Finish
C2136B	Classic Cabinet Glass Doors - Polished Brass Finish
C2136C	Classic Cabinet Glass Doors - Chrome Finish
P1136B	Premium Series Bi-fold Glass Doors - Polished Brass Finish
GR8	Integral Grate (included with Fireplace)
ID4	Insulated Duct/Outside Air
UD4	Uninsulated Duct/Outside Air
CAK4	Chimney Air Kit
SL306	Chimney Section - 6" long
SL312	Chimney Section - 12" long
SL318	Chimney Section - 18" long
SL324	Chimney Section - 24" long
SL336	Chimney Section - 36" long
SL348	Chimney Section - 48" long
SL3	Chimney Stabilizer
SL315	Chimney Offset/Return - 15°
SL330	Chimney Offset/Return - 30°
FS338	Firestop - Straight
FS339	Firestop - 15°
FS340	Firestop - 30°
AS8	SL300 Straight Attic Insulation Shield - 24"
JB877	Chimney Joint Band
CB876	Chimney Bracket
RF370	Roof Flashing - Flat to 6/12 Pitch
RF371	Roof Flashing - 6/12 to 12/12 Pitch
ST375	Chimney Terminal Cap - Square
CT35	Chase Top
TR342	Round Telescoping Terminal Cap
TR344	Round Telescoping Terminal Cap
TS345	Square Terminal Cap
TS345P	Square Terminal Cap - (TS345 Painted)

*Heatilator Catalog Number



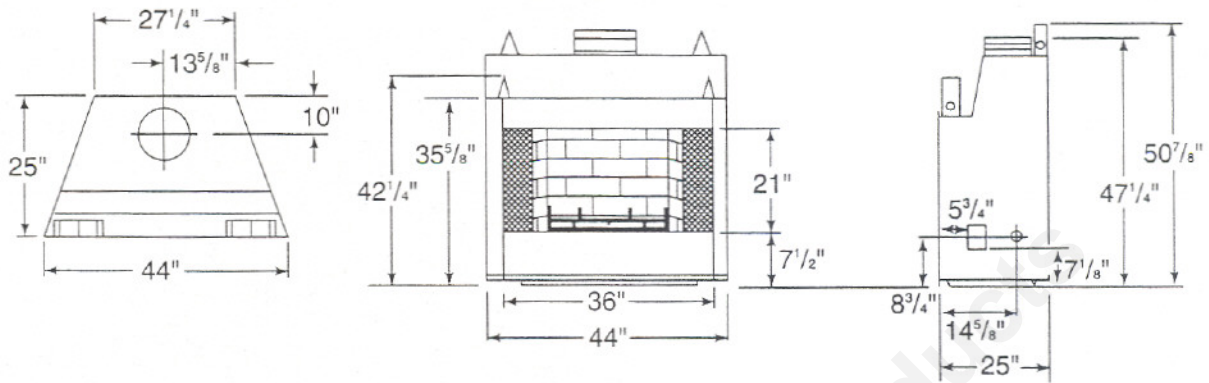

HEARTH EXTENSION

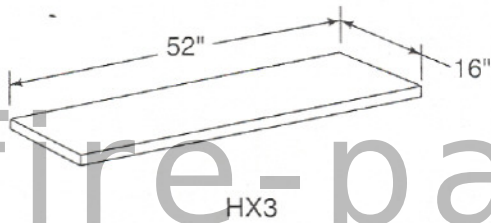

HX3

GLASS DOORS

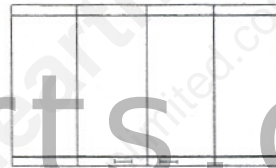

STRAIGHT ATTIC INSULATION SHIELD

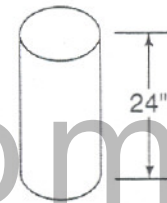

AS8

INTEGRAL GRATE

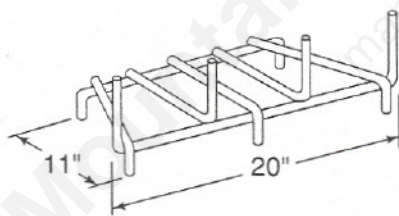

GR8

INSULATED DUCT

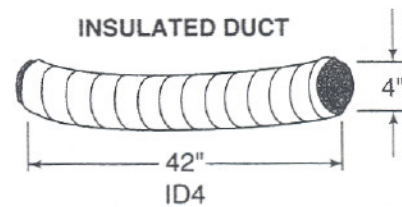

ID4

UNINSULATED DUCT

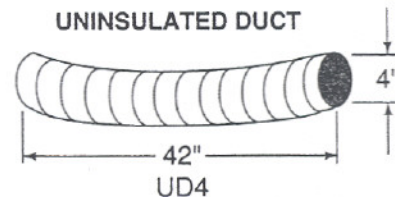

UD4

OUTSIDE AIR KIT (SUPPLIED)

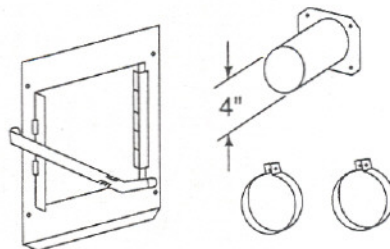

AK14



CHIMNEY SECTIONS

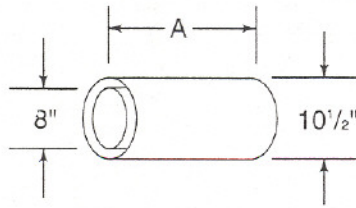

HTI CAT.#	A	B
SL306	6"	4 ³ / ₄ "
SL312	12"	10 ³ / ₄ "
SL318	18"	16 ³ / ₄ "
SL324	24"	22 ³ / ₄ "
SL336	36"	34 ³ / ₄ "
SL348	48"	46 ³ / ₄ "

A= Actual length
B= Effective length (length of chimney part after it has been snapped to another)

CHIMNEY STABILIZER

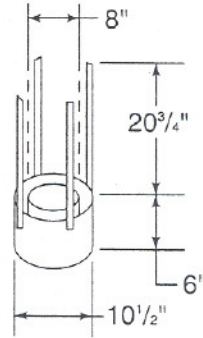

SL3

OFFSETS/RETURNS

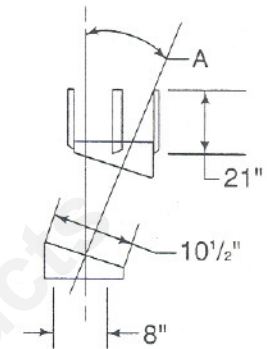

HTI CAT.#	A
SL315	15°
SL330	30°

fire parts.com

FIRESTOP SPACERS

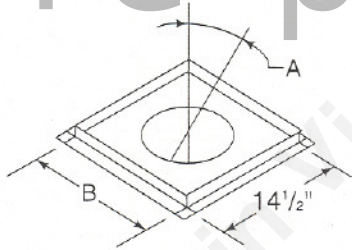

CAT. NO.	A	B
FS338	0°	14 ¹ / ₂ "
FS339	15°	18 ³ / ₈ "
FS340	30°	23"

ROOF FLASHING

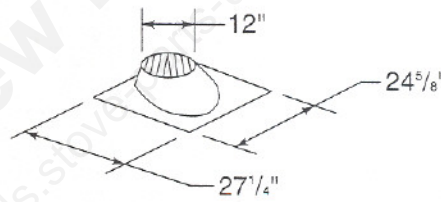

RF370
Flat to 6/12 Pitch

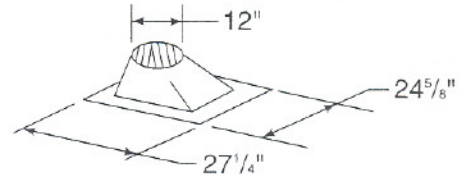

RF371
6/12 to 12/12 Pitch

CHIMNEY BRACKET

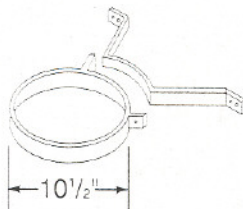

CB876

JOINT BAND

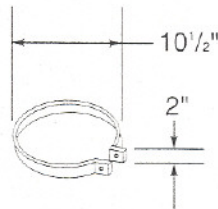

JB877

CHIMNEY AIR KIT

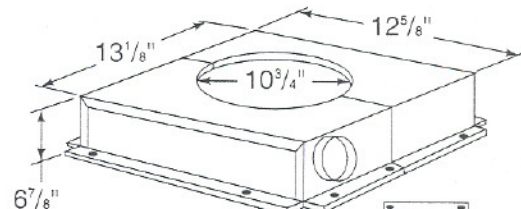

CAK4

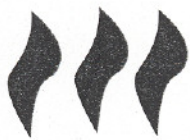

CHIMNEY TERMINAL CAPS & VENT SECTIONS

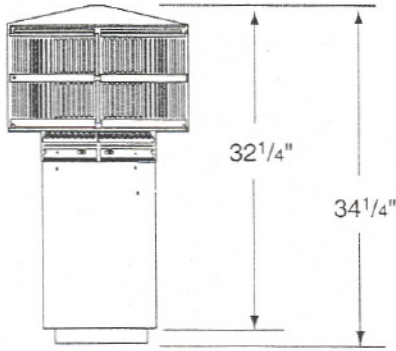

TR342
ROUND TELESCOPING
TERMINAL CAP

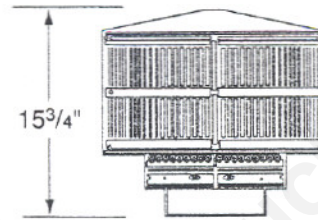

TR344
ROUND TERMINAL CAP
WITH STORM COLLAR

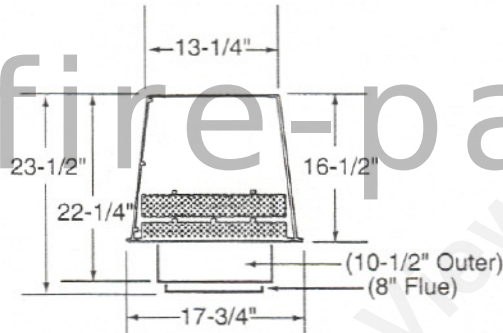

TS345/345P
SQUARE TERMINAL CAP

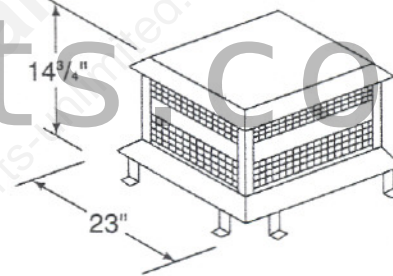

ST375
SQUARE TERMINAL CAP

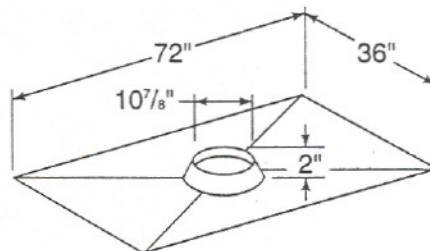

CT35
CHASE TOP

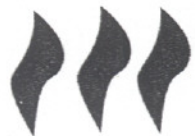

D. PRE-INSTALLATION PREPARATION

1. FIREPLACE LOCATIONS AND SPACE REQUIREMENTS

Several options are available to you when choosing a location for your fireplace. This fireplace may be used as a room divider, installed along a wall, across a corner or used in an exterior chase. See Figure 1.

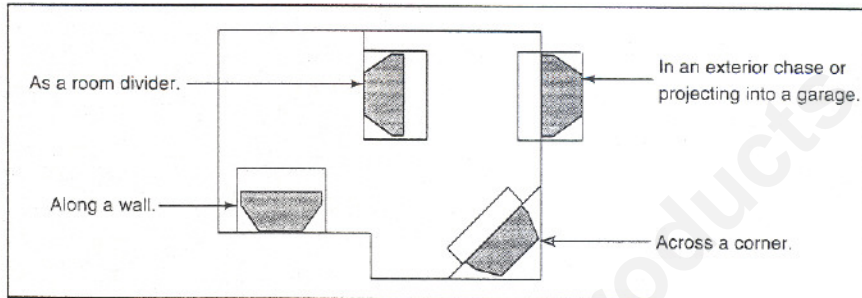
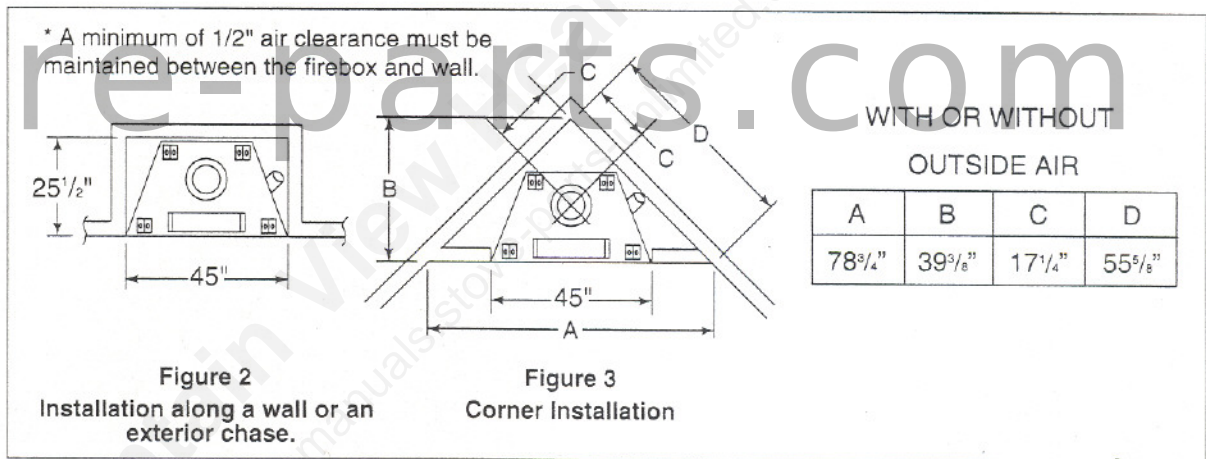

Figure 1
Fireplace Locations

Figures 2 and 3 show two typical installations assuming an outside air kit is being used. Therefore, an allowance must be made for 90° bends. Less space is required when ducting goes directly outside without forming elbows.



WARNING!

DO NOT DRAW OUTSIDE AIR FROM GARAGE SPACES. EXHAUST PRODUCTS OF GASOLINE ENGINES ARE HAZARDOUS.

DO NOT INSTALL OUTSIDE AIR DUCTS SUCH THAT THE AIR MAY BE DRAWN FROM ATTIC SPACES, BASEMENTS OR ABOVE THE ROOFING WHERE OTHER HEATING APPLIANCES OR FANS AND CHIMNEYS EXHAUST OR UTILIZE AIR. THESE PRECAUTIONS WILL REDUCE THE POSSIBILITY FOR SMOKING OR FLOW REVERSAL.

WARNING!

TO PREVENT CONTACT WITH SAGGING OR LOOSE INSULATION, THE FIREPLACE MUST NOT BE INSTALLED AGAINST VAPOR BARRIERS OR EXPOSED INSULATION. LOCALIZED OVERHEATING COULD OCCUR AND A FIRE COULD RESULT.

2. FRAMING THE FIREPLACE



The T3600 fireplace will fit a framed opening of 45" wide x 42" tall. The finished cavity depth must be no less than 25 1/2" .

Figure 4 shows a typical framing (using 2 x 4 lumber) of the fireplace, assuming combustible materials are used. All required clearances to combustibles around

the fireplace must be adhered to. Any framing across the top of the fireplace must be above the level of the top standoffs. An 1/2" air clearance must be maintained at the back and sides of the firebox assembly. Chimney Sections at any level require a 2" minimum air space clearance between the framing and chimney section.

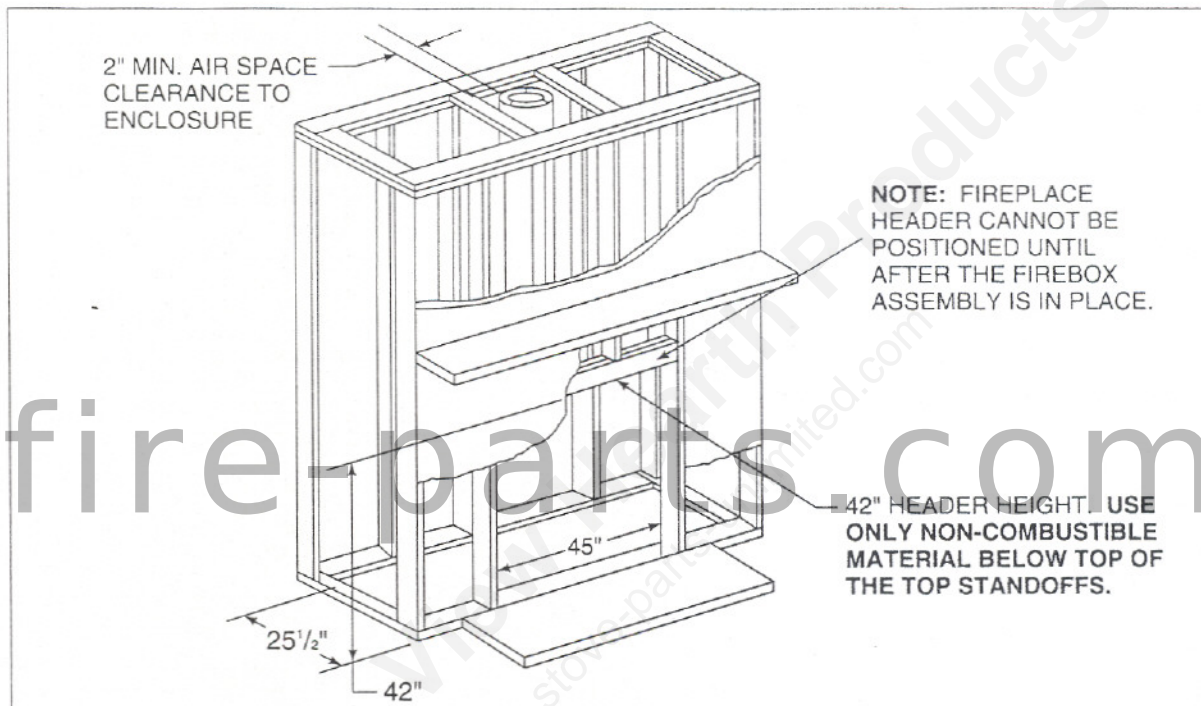

Figure 4
Framing the Fireplace

Combustible Material. Material made of or surfaced with wood, compressed paper, plant fibers, plastics, or any material capable of igniting and burning, whether flame proofed or not, plastered or unplastered.

Non-combustible Material. Material which will not ignite and burn. Such materials are those consisting entirely of steel, iron, brick, tile, concrete, slate, glass or plasters, or combination thereof.

Non-combustible Sealant Material. Sealants that will not ignite and burn; General Electric RTV103

(Black), or equivalent. Rutland, Inc. Fireplace Mortar #63, or equivalent.

After completing the framing and applying the facing material (dry wall) over the framing, a non-combustible sealant, one-half inch wide maximum, must be used to close off any gaps at the top and sides between the fireplace and facing to prevent cold air leaks

Only non-combustible materials may be used to cover the black metal fireplace front.

WARNING!

DO NOT APPLY COMBUSTIBLE FINISHING MATERIALS OVER ANY PART OF THE BLACK FACE OF THIS FIREPLACE OR A STRUCTURE FIRE MAY RESULT. THE BLACK METAL FACE MAY ONLY BE COVERED WITH NON-COMBUSTIBLE MATERIALS.



2. HEARTH EXTENSIONS

A hearth extension must be installed with all fireplaces. It is to protect the combustible floor in front of the fireplace from both radiant heat and sparks.

The construction of and materials used for a field constructed hearth extension are shown in Figure 5.

A hearth extension of this construction may be covered with any non-combustible decorative material and may have a maximum thickness of 7 1/2". Seal gaps between the hearth extension and the front of the fireplace with a non-combustible sealant.

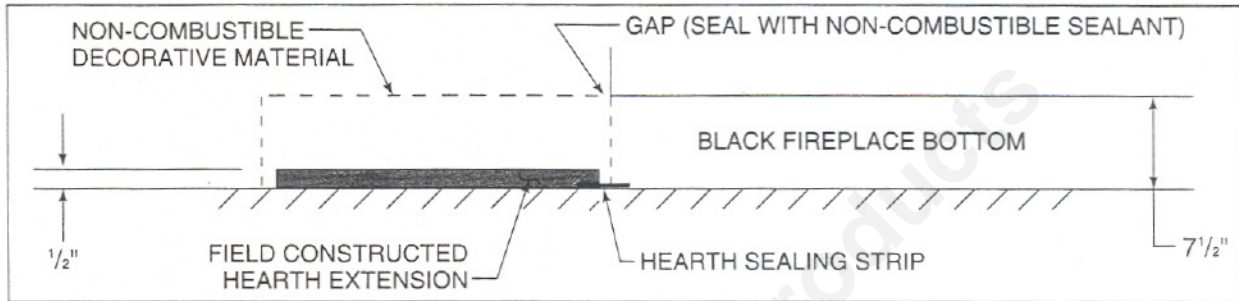

Figure 5
Field Constructed Hearth Extension

Field constructed Hearth Extensions should be constructed in accordance with Figures 5 and 6 instructions. In all cases, the hearth extension must extend a minimum of 16" to the front and 8" on either side of the fireplace opening. The field constructed hearth extension must be constructed from 1/2" MICORE CV230.

fire-parts.com

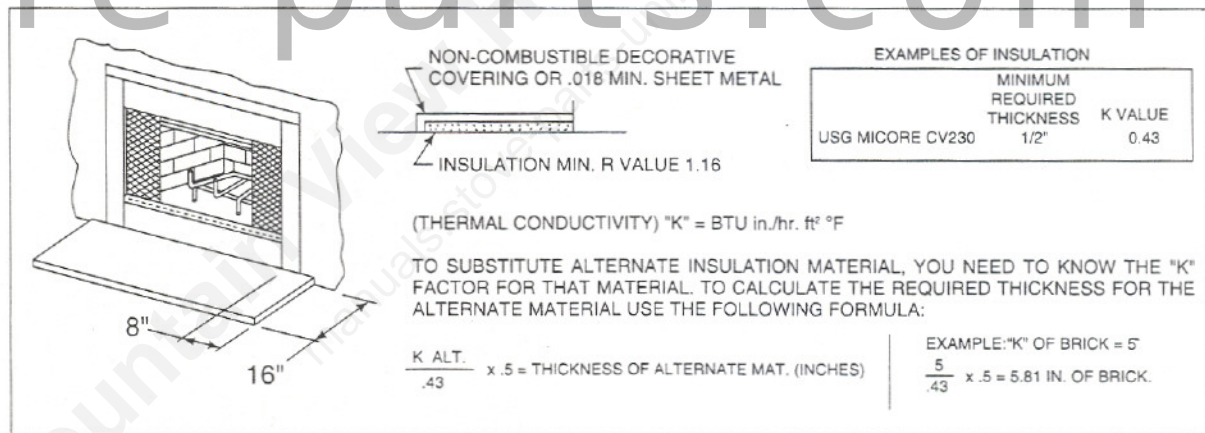

Figure 6
Hearth Extension

WARNING!

HEARTH EXTENSIONS ARE TO BE INSTALLED ONLY AS ILLUSTRATED TO PREVENT HIGH TEMPERATURES FROM OCCURRING ON CONCEALED COMBUSTIBLE MATERIALS. HEARTH SEALING STRIPS PREVENT BURNING OR HOT PARTICLES FROM INADVERTENTLY FALLING DIRECTLY ON COMBUSTIBLE SURFACES IN THE EVENT THE BUILDING SHOULD SETTLE AND DISTURB THE ORIGINAL CONSTRUCTION



4. SIDEWALLS/SURROUNDS

Adjacent combustible side walls must be located a minimum of 20" from the fireplace opening. See Figure 7. If you are using a decorative surround constructed of combustible material, it must be located within the shaded area defined in Figure 7. Short stub walls are also acceptable if they are contained within the shaded area.

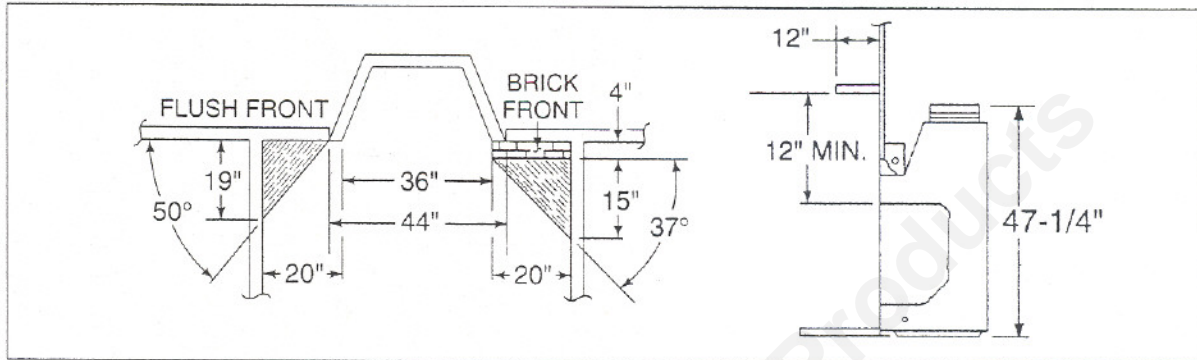

Figure 7
Sidewalls/Surrounds

5. MANTEL

A combustible mantel may be positioned no lower than 12" above the top of the firebox opening. The combustible mantel may have a maximum depth of 12". Combustible trim materials, projecting no more than 1-1/2" from the face of the fireplace, can be placed no closer than 6" from the top and side of the firebox opening. See the shaded areas on each side of the firebox, as defined in Figure 7. Combustible trim must not cover the black metal surfaces of the fireplace. This mantel clearance is in accordance with Section 7-3.3.3 of ANSI/NFPA 211.

E. CHIMNEY REQUIREMENTS

When planning your fireplace location, the chimney construction and necessary clearances must be considered. The fireplace system and chimney components have been tested to provide the following flexibility in construction. The following figures are the minimum distances from the base of the unit.

Minimum overall straight height	14.5 ft.
Minimum height with Offset/Return	16 ft.
Maximum height	90 ft.
Maximum chimney length between an Offset/Return	10 ft.
Maximum distance between Chimney Stabilizers	35 ft.
Double Offset/Return minimum height	20 ft.
Maximum unsupported chimney length between Offset/Return	6 ft.
Maximum straight unsupported chimney height above firebox	35 ft.

1. USING OFFSETS AND RETURNS.

To bypass any overhead obstructions, the chimney may be offset using a 15° offset/return (SL315) or a 30° offset/return (SL330). Perform the following steps to determine the correct chimney component combination for your particular installation.

An offset and return may be attached together or a chimney section(s) may be used between an offset and return. However, the distance between two elbows must never exceed 10 feet in total length.

- a. Measure how far the chimney needs to be shifted to enable it to avoid the overhead obstacle. See Figure 8, dimension "A".

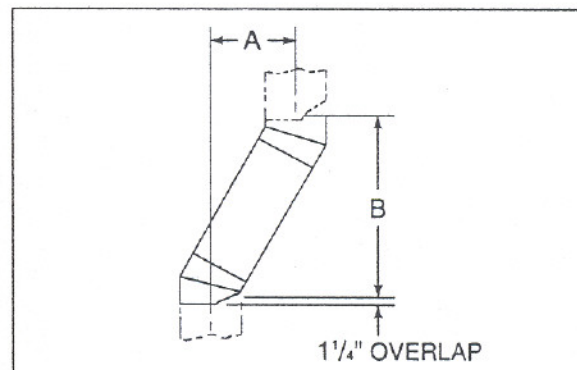

Figure 8
Chimney Offset/Return

- b. After determining the offset dimension, refer to Table 1 and find the "A" dimension closest to but not less than the distance of shift needed for your installation.
- c. The "B" dimension that coincides with the "A" dimension represents the required vertical clearance that is needed to complete the offset and return.
- d. Read across the chart and find the number of chimney sections required and the model number of those particular chimney parts.
- e. Whenever the chimney penetrates a floor/ceiling, a firestop spacer must be installed.

Example: Your "A" dimension from Figure 8 is 14½". Using Table 1, the dimension closest to but not less than 14½" is 14¾" using a 30° offset/return. It is then determined from the table that you would need 33" (Dimension "B") between the offset and return. The chimney components that best fit your application are two [2] SL312's.

WARNING!

DO NOT COMBINE OFFSETS TO CREATE AN OFFSET GREATER THAN 30° FROM VERTICAL. THIS MAY CREATE A FIRE HAZARD SINCE THE NATURAL DRAFT MAY BE RESTRICTED.

TABLE 1
30° Offset Chart* (Dimensions are in inches)

15°		30°		SL306	SL312	SL318	SL324	SL336	SL348
A	B	A	B						
15/8	133/8	37/8	141/2	-	-	-	-	-	-
27/8	173/8	61/4	185/8	1	-	-	-	-	-
-	-	85/8	223/4	2	-	-	-	-	-
41/2	235/8	91/4	233/4	-	1	-	-	-	-
-	-	115/8	277/8	1	1	-	-	-	-
6	293/8	121/4	29	-	-	1	-	-	-
71/4	34	145/8	33	-	2	-	-	-	-
-	-	151/4	341/8	-	-	-	1	-	-
-	-	175/8	381/4	1	-	-	1	-	-
-	-	205/8	431/2	-	-	2	-	-	-
105/8	463/4	211/4	445/8	-	-	-	-	1	-
117/8	513/8	235/8	483/4	1	-	-	-	1	-
-	-	265/8	537/8	-	-	-	2	-	-
133/4	583/8	271/4	553/4	-	-	-	-	-	1
15	63	295/8	59	1	-	-	-	-	1
161/2	683/4	325/8	641/4	-	1	-	-	-	1
18	745/8	355/8	691/2	-	-	1	-	-	1
-	-	385/8	745/8	-	-	-	1	-	1
-	-	41	783/4	1	-	-	1	-	1
223/4	917/8	445/8	85	-	-	-	-	1	1
24	961/2	47	891/8	1	-	-	-	1	1
257/8	1031/2	505/8	951/2	-	-	-	-	-	2

*Proper assembly of air cooled chimney parts result in an overlap at chimney joints of 1¼". Effective length is built into this chart.

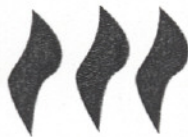

2. CHIMNEY HEIGHT REQUIREMENTS (Above the roof line)

Major building codes specify a minimum chimney height above the roof top. These specifications are summarized in what is known as the "Ten Foot Rule". This rule states:

If the horizontal distance from the side of the chimney to the peak of the roof is 10 feet or less, the top of the chimney must be at least 2 feet above the peak of the roof, but never less than 3 feet in overall height above the highest point where it passes through the roof. See Figure 9.

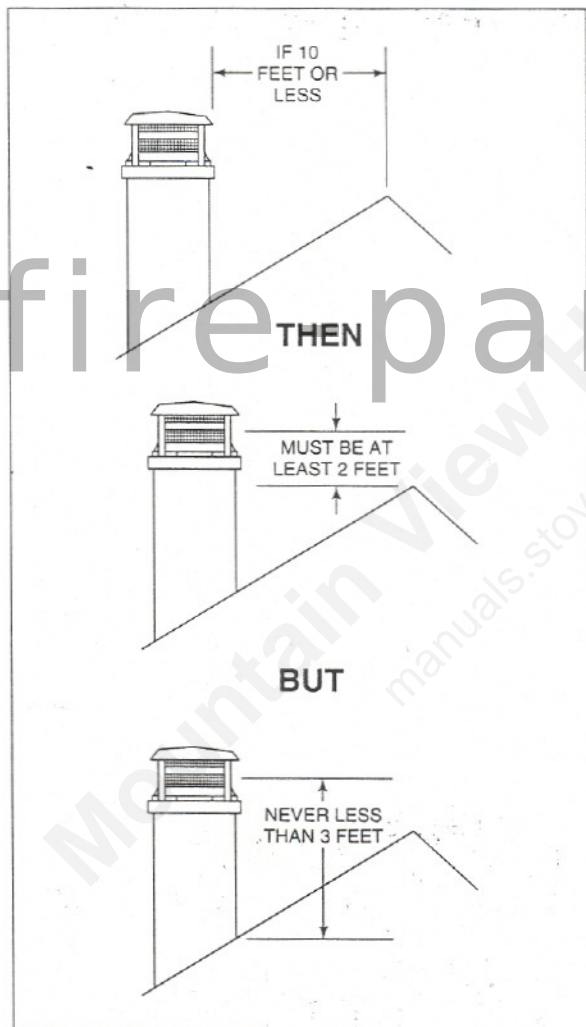

Figure 9
Chimney Height

If the horizontal distance from the side of the chimney to the peak of the roof is more than 10 feet, a chimney height reference point is established on the surface of the roof a distance of 10 feet from the side of the chimney in a horizontal plane. The top of the

chimney must be at least 2 feet above this reference point, but never less than 3 feet in height above the highest point where it passes through the roof.

These chimney heights are necessary in the interest of safety and do not ensure smoke-free operation. Trees, buildings, steeply pitched roofs, adjoining roof lines, adverse wind conditions, etc., may create a need for a taller chimney should smoking occur.

3. DETERMINING THE NUMBER OF CHIMNEY SECTIONS REQUIRED

To determine the chimney components needed to complete your particular installation, follow the below steps:

- Determine the total vertical height of the fireplace installation. This dimension is measured from the base of the firebox assembly to the point where the smoke exits the terminal cap.
- Subtract the height of the firebox assembly (47-1/4") from the overall height of the fireplace installation.
- Reference the chart below to determine what components must be selected to complete the fireplace installation.
- Determine the number of firestop spacers, stabilizers, roof flashing, etc. required to complete the fireplace installation.

Height of Chimney Components	
Chimney Stabilizer	
SL3	4¾"
Firestop Spacers	
FS338	0
FS339	0
FS340	0
Offset/Returns	
SL315	13¾"
SL330	14½"
Roof Flashing	
RF370	0
RF371	0
Chimney Sections*	
SL306	4¾"
SL312	10¾"
SL318	16¾"
SL324	22¾"
SL336	34¾"
SL348	46¾"

*Dimensions reflect effective height.

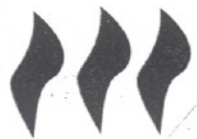

F. STEP-BY-STEP INSTALLATION OF THE FIREPLACE SYSTEM

WARNING!

BEFORE STARTING, DO THE FOLLOWING:

1. WEAR GLOVES AND SAFETY GLASSES FOR PROTECTION.
2. KEEP HAND TOOLS IN GOOD CONDITION. SHARPEN CUTTING EDGES AND MAKE SURE TOOL HANDLES ARE SECURE.
3. ALWAYS MAINTAIN THE MINIMUM AIR SPACE REQUIRED TO THE ENCLOSURE TO PREVENT FIRE.

STEP 1 - Positioning the Fireplace.

This fireplace may be placed on either a combustible or non-combustible continuous surface. Follow the instructions for framing on page 9. Be sure to provide the minimum 1/2" air clearance at the sides and back of the firebox assembly.

NOTE: The firebox assembly must be in position prior to nailing the fireplace headers in place.

STEP 2 - Placing the Protective Metal Hearth Strips.

Included with your fireplace you will find two metal hearth strips measuring approximately 28" x 4". These strips are used to provide added protection where the fireplace and hearth extension meet.

Slide the metal strips two inches under the front edge of the fireplace. The individual pieces must overlap each other by one inch in the middle of the fireplace to provide continuous coverage of the floor. See Figure 10. These metal strips should extend from the front and sides of the fireplace by 2".

STEP 3 - Leveling the Fireplace.

Level the fireplace side-to-side and front-to-back. Shim with non-combustible material, such as sheet metal, as necessary.

Important: To ensure proper fit of the glass doors, check the firebox opening for squareness. Measure diagonal distances of the opening to make sure they are equal. If they do not equal, continue to shim the firebox until those diagonals correspond.

Secure the fireplace by utilizing the nailing flanges located on either side of the fireplace to the vertical framing.

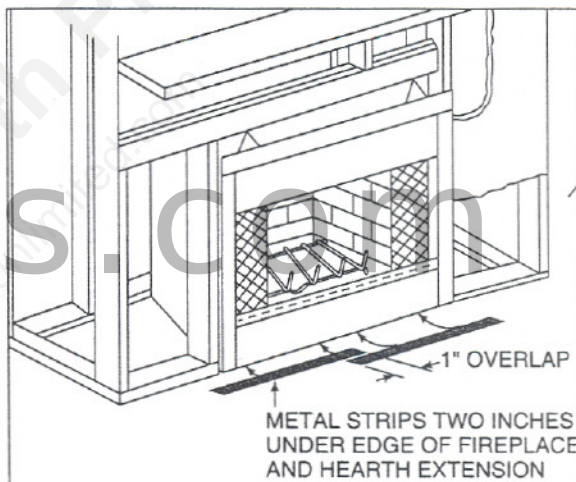

Figure 10
Positioning the Metal Strips

WARNING!

CAREFULLY FOLLOW THE INSTRUCTIONS FOR ASSEMBLY OF THE PIPE AND OTHER PARTS NEEDED TO INSTALL THIS FIREPLACE SYSTEM. FAILURE TO DO SO MAY RESULT IN A FIRE, ESPECIALLY IF COMBUSTIBLES ARE TOO CLOSE TO THE FIREPLACE OR CHIMNEY AND AIR SPACES ARE BLOCKED PREVENTING THE FREE MOVEMENT OF COOLING AIR.



STEP 4 - Assembling Chimney Sections.

Attach either a straight chimney section or an offset to the top of the fireplace depending on your installation requirement. Chimney sections are locked together by pushing downward until the top section meets the stop bead on the lower section. When using offsets/returns, it is highly recommended that the offset and return sections be secured in place with screws to ensure proper orientation. See Figure 11.

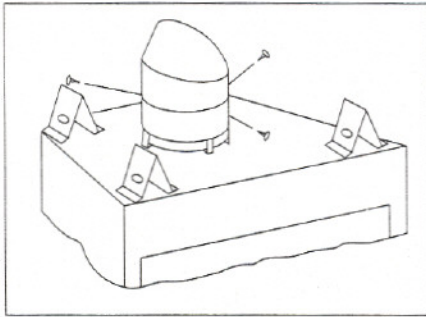

Figure 11
Connecting Chimney Sections

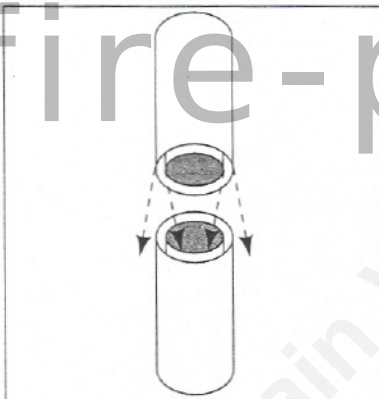

Figure 12
Connecting Chimney Sections

NOTE: The inner flue is placed to the inside of the flue section below it. The outer casing is placed outside the outer casing of the chimney section below it. See Figure 12.

to the ceiling joists from the bottom or fireplace side, **EXCEPT** when the space above is an insulated ceiling or attic space. In this situation, the firestop spacer must be nailed from the top side to prevent loose insulation from falling into the required two inch air space around the chimney. See Figure 13.

Firestop spacers must be used whenever the chimney penetrates a ceiling/floor area.

CAUTION:

INNER FLUE AND OUTER LINER SECTIONS CANNOT BE DISASSEMBLED ONCE LOCKED TOGETHER. PLAN AHEAD TO INSURE THE PROPER INSTALLATION HEIGHT IS ACHIEVED WITH THE SELECTED CHIMNEY COMPONENTS.

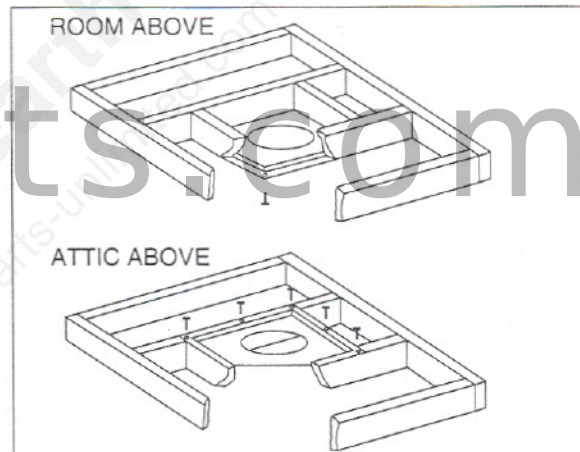

Figure 13
Installing the Firestop Spacer

STEP 5 - Preparing the Ceiling for Firestop Spacers.

Mark and cut out an opening in the ceiling for the particular firestop spacer being utilized (14-1/2" x 14-1/2" for an FS338, or 14-1/4" x 18-3/4" for an FS339, or 14-1/2" x 23" for an FS340). Frame the opening with the same dimension lumber used in the ceiling joists.

STEP 6 - Installing the Firestop Spacers.

Install the firestop spacer FS338 (Straight), FS339 (if a 15° offset is located in the ceiling joist area), or FS340 (if a 30° offset is located in the ceiling joist area). Nail the four sides of the firestop spacer to the joists using a minimum of three [3] nails per side.

These firestop spacers are designed to provide the minimum 2" air space required around the chimney. In all situations, the firestop spacers are to be nailed

STEP 7 - Installing an AS8 Insulation Shield.

An AS8 insulation shield should be installed when there is a possibility of insulation coming into contact with the factory-built chimney system. The AS8 is installed by positioning it over the vertical chimney section where it penetrates an FS338 firestop spacer. The FS338 will support the AS8. See Figure 14. When the factory-built chimney penetrates an insulated ceiling at either 15 or 30 degrees from vertical, an insulation dam should be constructed from plywood or sheet metal. A minimum 2" air space must be provided between the insulation dam and the factory-built chimney system.



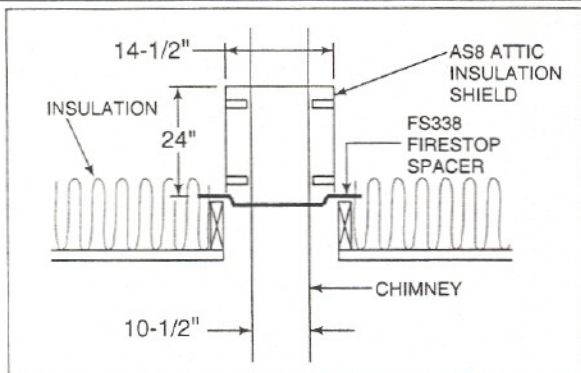

Figure 14 - Installing an AS8

STEP 8 - Double-checking Chimney Assembly.

Continue assembling the chimney sections up through the firestop spacers as needed. While doing so, be aware of the height and unsupported chimney length limitations that are given on page 11 under "Chimney Requirements".

Check each section by pulling up slightly from the top to ensure proper engagement before installing the succeeding sections. If they have been connected correctly, they will not disengage when tested.

STEP 9 - Securing Chimney System.

When offsets and returns are joined to straight pipe sections, they must be locked into position with the screws provided, using the predrilled holes. To prevent gravity from pulling the chimney sections apart, the returns and the chimney stabilizers have straps for securing these parts to joists or rafters. See Figure 15.

NOTE: Be sure to provide support for the pipe during construction and check to be sure inadvertent loading has not dislodged the chimney section from the fireplace or at any chimney joint.

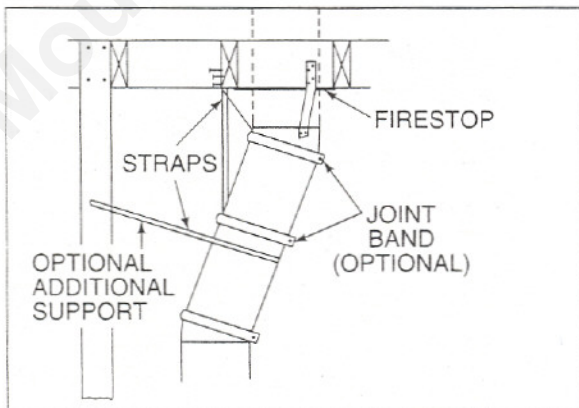

Figure 15
Offset/Return with Stabilizer

WARNING!

WHEN CHIMNEY SECTIONS EXCEEDING SIX FEET IN LENGTH ARE INSTALLED BETWEEN AN OFFSET/ RETURN. STRUCTURAL SUPPORT MUST BE PROVIDED TO REDUCE OFF-CENTER LOADING AND PREVENT CHIMNEY SECTIONS FROM SEPARATING AT THE CHIMNEY JOINTS.

STEP 10 - Marking the Exit Point of the Roof.

Locate the point where the chimney will exit the roof by plumbing down to the center of the chimney. Drive a nail up through the roof to mark the center. See Figure 16.

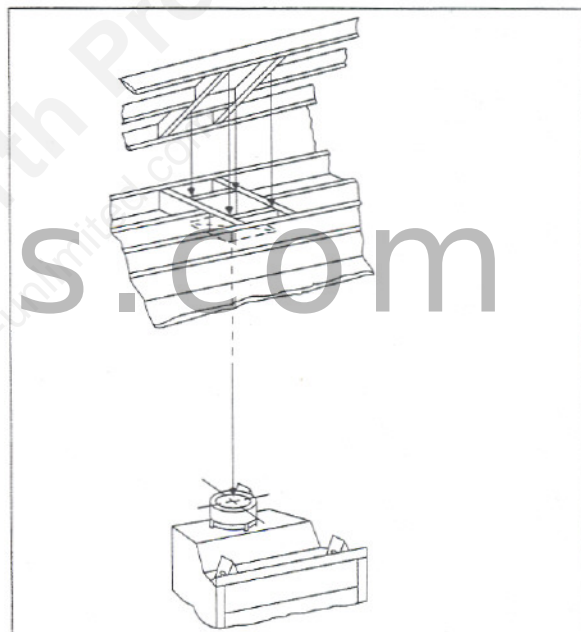

Figure 16 - Ceiling and Attic Construction

STEP 11 - Cutting out the Hole in the Roof.

Measure to either side of the nail and mark the 14-1/2" x 14-1/2" opening required. This is measured on the horizontal; actual length may be larger depending on the pitch of the roof. Cut out and frame the opening. See chapter 25 of the Uniform Building Code for Roof Framing details. Be sure to maintain a 2" minimum air space between the chimney section and the roof.

STEP 12 - Assembling Chimney Sections.

Continue to add chimney sections through the roof opening, maintaining at least a 2" air space.

STEP 13 - Installing the Roof Flashing (optional).

If a roof flashing is to be used, install the roof flashing appropriate to the roof pitch and install a TR344 terminal cap following the instructions shipped with the accessory.



STEP 14 - Installing the CAK4.

When installing a CAK4 chimney air kit, follow the instructions provided with this accessory. Use of a CAK5 is required in Canada.

STEP 15 - Installing an Outside Air Kit (standard).

The outside air kit is supplied as a standard feature with this fireplace and its use is highly recommended to minimize the effects of negative pressure within the structure. Figure 17 illustrates two of many possible methods that can be used to supply outside air to the fireplace system.

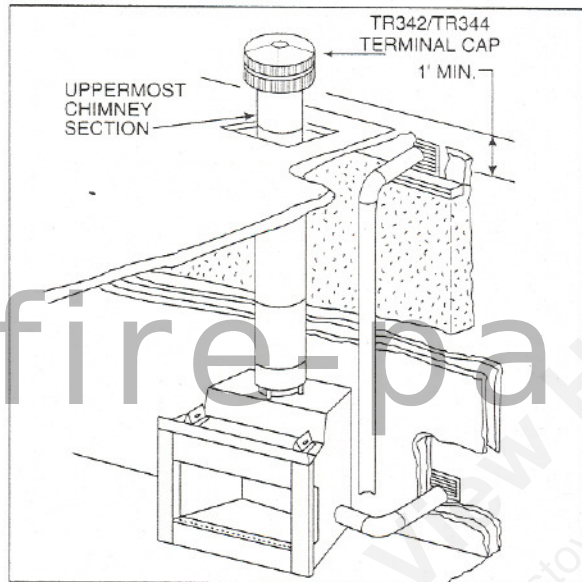

Figure 17
Outside Air Location

NOTE: The outside air kit can terminate at any level with the exception that it must terminate at least one foot below the chimney terminal cap as shown in Figure 17.

The outside air kit may be installed on either the left hand or right hand side of the fireplace. Remove the cover plate from the side of the firebox assembly where the air kit is to be installed. See Figures 18 and 19.

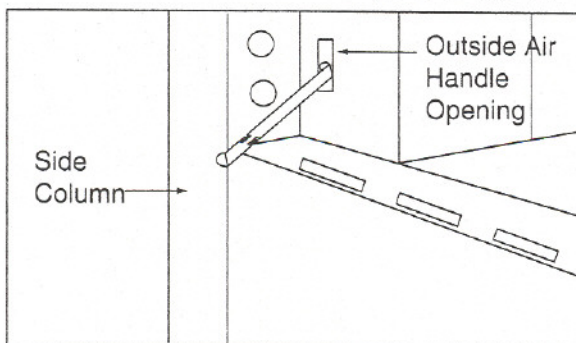

Figure 18 - Air Kit Installation

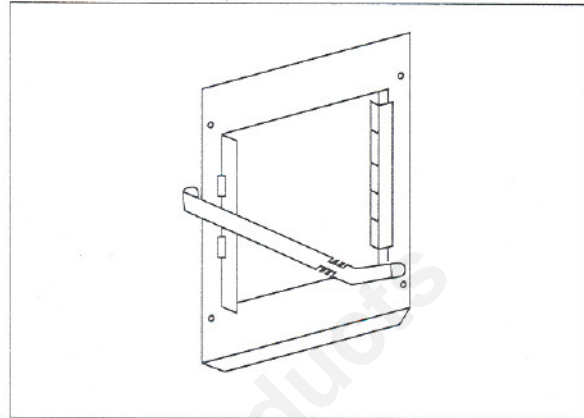

Figure 19
Air Kit Handle Assembly

STEP 16 - Completion of Fireplace Enclosure.

Complete the fireplace enclosure, allowing space for outside air ducts and gas piping if desired. Electrical wiring should not come in contact with the unit. A minimum clearance of an 1/2" must be maintained between the fireplace sides and the enclosure as well as the fireplace back and the enclosure. See Figure 4 for framing details.

NOTE: Use only a non-combustible material to finish the face of the fireplace below the level of the front standoffs. A non-combustible material such as USG MICORE CV230 Mineral Fiber Board, or USG DUROCK Cement Board is recommended for this purpose.





STEP 17 - Provisions for a Gas Log Set or Gas Log Lighter.

Knockouts are provided on both sides of the fireplace for the connection of a certified gas log lighter or a decorative gas appliance with a maximum input of 100,000 BTU/hr incorporating an automatic gas shutoff device and complying with the Standard for Decorative Gas Appliances for Installation in Vented Fireplaces, ANSI Z21.60. The decorative gas appliance should be installed in accordance with the National Fuel Gas Code, ANSI Z223.1. The side refractories are designed to allow 1/2" iron pipe to pass through. Use a non-combustible sealant to seal any opening between the gas pipe and the refractory on the inside. Repack the insulation removed, to seal around the gas pipe where it exits the side of the fireplace. A minimum 1-1/2" air clearance must be provided to the 1/2" iron pipe. See Figure 20 for the shaded area.

CAUTION:

WHEN USING A GAS LOG SET, THE FIREPLACE DAMPER MUST BE SET IN THE FULLY-OPEN POSITION. THIS ENSURES A PROPER VENTING OF COMBUSTION PRODUCTS.

STEP 18 - Installing the Glass Doors.

If desired, or required by local building codes, install the glass doors using the instructions supplied with the particular set of doors you have chosen.

STEP 19 - Positioning the Hearth Extension.

Position and secure the hearth extension over the protective metal strips that have been placed partially under the firebox front. These strips should be protruding approximately two inches from under the fireplace front. Seal the crack between the hearth extension and fireplace with a non-combustible sealant.

STEP 20 - Applying Finishing Materials on the Hearth Extension.

Apply the non-combustible finishing material of your choice to the hearth extension. **Do not install combustible materials over the black face of the fireplace.** This poses a safety hazard and may start a fire. You may only use non-combustible material over the black face of the fireplace. Refer to Figure 7 for combustible material information.

f

WARNING!

THIS FIREPLACE WAS NOT TESTED BY THE FIREPLACE MANUFACTURER FOR USE WITH AN UNVENTED GAS LOG HEATER. DO NOT INSTALL AN UNVENTED GAS LOG HEATER IN THIS FIREPLACE UNLESS IT HAS BEEN SPECIFICALLY TESTED AND LISTED BY UNDERWRITERS LABORATORIES INC FOR USE IN THIS SPECIFIC MODEL FIREPLACE. UNLESS THE UNVENTED GAS LOG HEATER IS TESTED AND LISTED FOR USE IN THIS FACTORY-BUILT FIREPLACE, A FIRE HAZARD MAY BE CREATED THAT CAN RESULT IN A STRUCTURE FIRE.

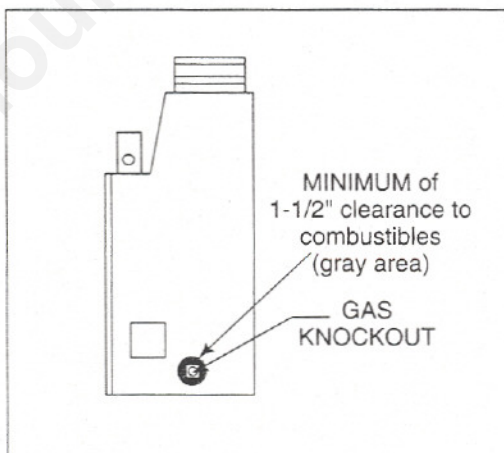

Figure 20
Gas Knockout Location

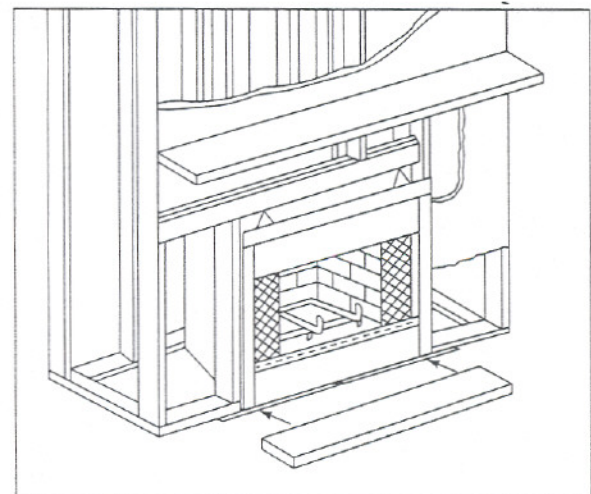

Figure 21
Positioning the Hearth Extension



G. CONSTRUCTING A CHASE

A chase is a vertical box-like enclosure built around the chimney and firebox. A chase may be constructed for the fireplace and chimney or for the chimney only. It is most commonly constructed on an outside wall.

In cold climates, it is recommended that the chase floor be insulated using batt type insulation between the floor joists.

Three examples of chase applications are shown in Figure 22.

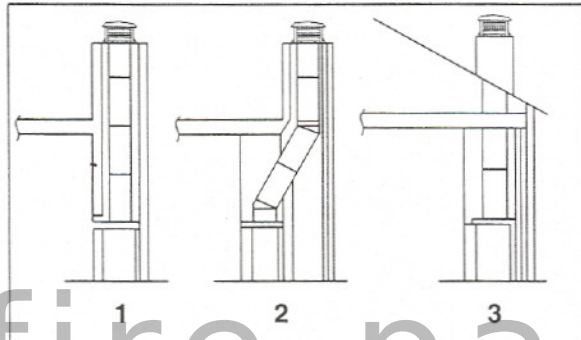

Figure 22
Chase Constructions

- Fireplace and chimney enclosed in an exterior chase.
- Chimney offset through exterior wall and enclosed in chase.
- Chase constructed on roof.

1. Materials for the Chase

The chase is constructed using framing materials much the same as the walls in your home. A variety of materials may be used including brick, stone, veneer brick, or standard siding materials.

In constructing the chase, several factors must be considered.

- Maintain an 1/2" minimum air space around the firebox.
- Maintain a 2" air space around the chimney.
- The chase top must be constructed of a non-combustible material.

- In cold climates a firestop spacer should be installed in an insulated false ceiling at the 8 foot level above the firebox assembly. This prevents heat loss through the fireplace.
- In cold climates, the walls of the chase should be insulated to the level of the false ceiling as shown in Figure 23. This will help prevent heat loss from the home around and through the fireplace.

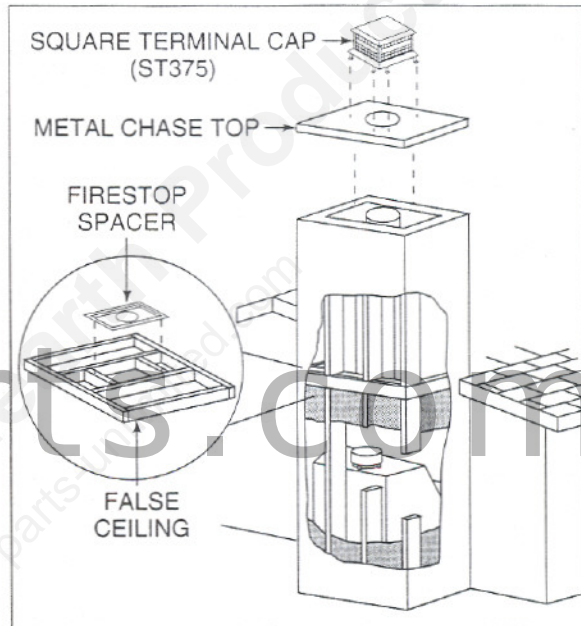

Figure 23 - Chime Assembly

WARNING!

DETAIL INSTRUCTIONS FOR INSTALLATION OF THE CHASE TOP, STORM COLLAR AND TERMINAL CAP ARE PACKAGED WITH THESE PARTS. TO AVOID DANGER OF FIRE, ALL INSTRUCTIONS MUST BE STRICTLY FOLLOWED, INCLUDING THE PROVISION OF AIR SPACE CLEARANCE BETWEEN CHIMNEY SYSTEM AND ENCLOSURE. TO PROTECT AGAINST EFFECTS OF CORROSION ON THOSE PARTS EXPOSED TO THE WEATHER, WE RECOMMEND THAT THE CHASE TOP AND TERMINAL CAP BE PAINTED WITH A RUST RESISTANT PAINT.



2. Installing a Terminal Cap on a Chase Enclosed Chimney.

Construct a chase of desired materials maintaining a minimum 2" air space around the chimney.

WARNING!

NEVER INSTALL A SINGLE WALL SLIP SECTION OR SMOKE-PIPE IN A CHASE STRUCTURE. THE HIGHER TEMPERATURE OF THIS SINGLE WALL PIPE MAY RADIATE SUFFICIENT HEAT TO COMBUSTIBLE CHASE CONSTRUCTION MATERIALS TO CAUSE A FIRE.

For installations utilizing a telescoping round terminal cap (TR342), the uppermost chimney section must be below the top of the chase top, but not more than 14-1/2" below the top of the chase top flashing collar.

For installations utilizing a square terminal cap (ST375), the last chimney section must not be more than 4-3/4" below the chase top. See Figure 24.

When installing a TS345 Square Termination, the uppermost chimney section must not be more than 3" below the chase top. See Figure 24.

Attach the chase top (CT35) to the top of the chase.

Install the terminal cap, using the instructions provided with it.

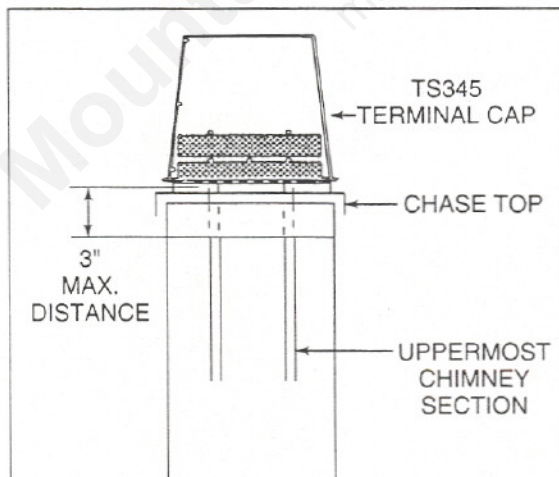

Figure 24
Installing a Terminal Cap

H. OPERATING INSTRUCTIONS

NOTICE:

SAVE AND PASS THESE OPERATING INSTRUCTIONS AND THE INSTALLATION INSTRUCTIONS TO SUBSEQUENT OWNERS. THE INFORMATION PROVIDED IS INTENDED TO NOTIFY AND WARN THEM ABOUT MAKING UNSAFE FUTURE MODIFICATIONS SUCH AS THE ADDITION OF SHELVES OR THE USE OF UNAUTHORIZED PARTS AND REPAIRS.

This fireplace is intended to operate as a supplemental heat source for a single room. It is not designed to function as a primary heat source for a structure.

Fireplaces, as well as other woodburning appliances, have been used safely for many years. It has been our experience that most problems are caused by the improper installation and operation of the unit. Make certain installation and operation of the fireplace system is in accordance with these instructions.

It is extremely important that the fire be supervised whenever the fireplace is in use. It is also recommended that an annual inspection be performed on the fireplace system to determine if the flue system needs to be cleaned, or as in the case of any appliance, if minor repairs are required to maintain the system in top operating condition.

INTENDED USAGE. This factory-built fireplace is intended for use with either solid fuel (firewood) or a decorative gas appliance that has been tested and listed to the Standard for Decorative Gas Appliances for Installation in Vented Fireplaces, ANSI Z21.60. **When operating your fireplace, the flue damper must be in the open position.**

This fireplace was not tested and listed for use with an unvented gas log heater. Do not install an unvented gas log heater in this fireplace and operate it with the flue damper in the closed position unless the unvented gas log set has been specifically tested and listed for use in this fireplace by Underwriters Laboratories Inc. Use of an unvented gas log heater in this factory-built fireplace may create a fire hazard that can result in a structure fire.

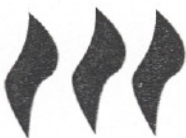

WARNING!

DO NOT OPERATE THIS FIREPLACE WITH THE FLUE DAMPER IN THE CLOSED POSITION. COMBUSTION PRODUCTS MUST VENT UP THE CHIMNEY SYSTEM TO PREVENT CARBON MONOXIDE POISONING, AND TO PREVENT HOT COMBUSTION GASES FROM CONTACTING AND OVERHEATING COMBUSTIBLE SURFACES. FAILURE TO OPERATE THIS FIREPLACE WITH THE DAMPER IN THE OPEN POSITION MAY RESULT IN ASPHYXIATION OR A STRUCTURE FIRE.

CAUTION:

FIREPLACE OPERATION DOES REQUIRE AIR. DO NOT TAKE AIR FROM OTHER FUEL BURNING APPLIANCES WHICH CAN RESULT IN IMPROPER VENTING (SMOKING) OR AIR DILUTION. ALWAYS PROVIDE ADEQUATE MAKE-UP AIR.

STARTING THE FIRE. Check the flue damper to be certain it is in the full open position. Place crumpled or twisted paper under the fireplace grate. Loosely arrange kindling and small pieces of wood to form a layer above the paper. Light the paper and add small pieces of wood until a hot bed of embers has been established. At this point, add progressively larger pieces of wood until you are able to position 4" diameter split logs as shown in Figure 25.

When first lighting your fireplace, it may be necessary to pre-warm the flue to establish a draft. This is done by holding a rolled up piece of burning newspaper under the flue damper for a few moments. This will prevent smoke spillage during start-up.

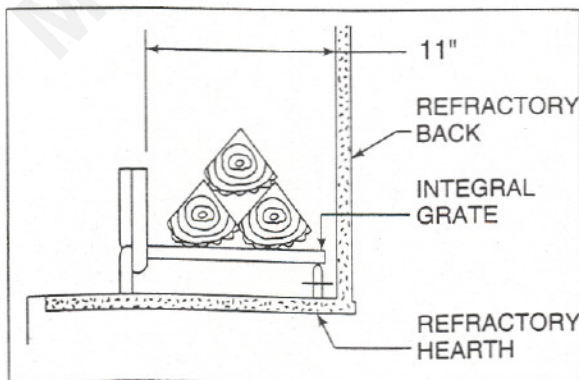

Figure 25
Sectional View of Fireplace

Firewood should be seasoned for at least 6 months before it can be burned as a fireplace fuel. Improperly seasoned (green or wet) wood will cause the fireplace to smoke, will allow creosote deposits to rapidly buildup in the chimney system and may cause roof stains to develop.

Fuel products with abnormal burning characteristics, including synthetic logs that contain wax binders, scrap lumber, wax or plastic coated cardboard and other highly volatile fuels that burn at excessive temperatures, may cause the fireplace to operate in an unsafe manner. Flammable liquid fuels are explosive and must never be used to start or freshen a fire. Heatilator does not warrant the structural or functional performance of the fireplace system when such synthetic fuels or flammable liquids have been used.

NOTE: When heated for the first several times, the fireplace should be heated gradually to prevent moisture in the refractory from causing cracks and to allow binders in the insulation to dissipate. You will notice an industrial odor during the first few fires that are burned. This is considered to be normal.

Use only a solid wood fuel or a listed Heatilator gas log set. Do not use a fireplace insert or products not specifically tested and listed for use in this fireplace. Use common sense when burning this fireplace. The fire must be built on the fireplace grate, without danger of the burning fuel falling out of the firebox.

CAUTION:

NEVER USE GASOLINE, GASOLINE-TYPE LANTERN FUEL, KEROSENE, CHARCOAL LIGHTER FLUID, OR SIMILAR LIQUIDS TO START OR 'FRESHEN UP' A FIRE IN THIS FIREPLACE. KEEP ALL SUCH LIQUIDS WELL AWAY FROM THE FIREPLACE WHILE IT IS IN USE TO AVOID THE RISK OF A HOSTILE FIRE.

DISPOSAL OF ASHES. Ashes should be placed in a metal container with a tight-fitting lid. The closed container of ashes should be placed on a non-combustible floor or on the ground, well away from all combustible materials, pending final disposal. If the ashes are disposed of by burial in soil or otherwise locally dispersed, they should be retained in the closed container until all cinders have thoroughly cooled.



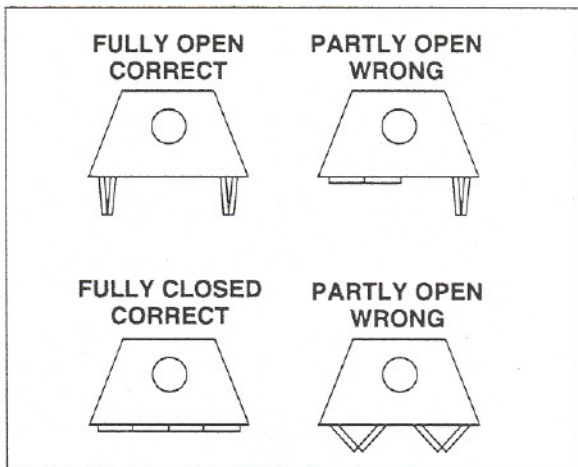

Figure 26
Recommended Operating Positions of Doors

GLASS DOORS. Most efficient fireplace operation using glass doors is with the doors open. When the doors are open, the screen must be closed. Only glass doors, model numbers: DM1136, DM1136A, DM1136B, C1136A, C1136B, C1136C, C2136A, C2136B, C2136C or P1136B may be used on this fireplace.

Before starting a fire in your T3600 fireplace, use the following check list:

FLUE DAMPER. The flue damper is operated by pushing the handle up toward the top of the firebox, which should place the damper in a fully open position. Verify this by looking up from the inside of the firebox. Always operate this fireplace with the damper fully open. Please note, down drafts, obstructions, damage or poor (wet) fuels can cause smoke spillage.

CHIMNEY INSPECTION. Visually inspect the chimney internally for obstructions and construction damage. Flue pipe joints and seams must be continuous and mechanically tight. In a used chimney, additional inspection is needed for creosote build-up which is the formation of a flammable sediment.

When wood is burned slowly, it produces tar and other organic vapors, which combine with expelled moisture to form creosote. The creosote vapors condense in the relatively cool chimney flue of a slow-burning fire. As a result, creosote residue accumulates on the flue lining. When ignited, this creosote makes an extremely hot fire.

The chimney should be inspected at least twice a year during the heating season to determine if creosote build-up has occurred.

If creosote has accumulated, it should be removed to reduce the risk of a chimney fire.

CHIMNEY CLEANING. If you do detect a build-up of creosote, contact a qualified chimney sweep or clean it yourself. To do this, perform the following steps:

1. Open the damper.
2. Hang a damp sheet across the fireplace opening to stop dirt and soot from entering the room.
3. Remove the Terminal Cap or Housing Top. See Figure 27.
4. Clean with a stiff nylon brush attached to a pole **OR** tie a rope to a burlap bag filled with straw and several small stones or sand. Work up and down the flue until clean.
5. Replace the terminal cap or housing top.

WARNING!

FIREPLACES EQUIPPED WITH DOORS SHOULD BE OPERATED ONLY WITH DOORS FULLY OPEN OR FULLY CLOSED. IF DOORS ARE LEFT PARTIALLY OPEN, GAS AND FLAME MAY BE DRAWN OUT OF THE FIREPLACE OPENING, CREATING THE RISK OF BOTH FIRE AND SMOKE.

WARNING!

CONTINUED OVER-FIRING CAN PERMANENTLY DAMAGE YOUR FIREPLACE SYSTEM. EXAMPLES OF OVER-FIRING ARE:

1. THE "NORMAL LOG FIRE" SHOULD BE CONTAINED IN THE GRATE, WITH THE LENGTH OF LOGS NO GREATER THAN THE BACK WALL OF THE FIREPLACE.

2. THE FOLLOWING MATERIALS MUST NOT BE USED IN THIS FIREPLACE: QUANTITIES OF SCRAP LUMBER, PINE BRANCHES, PROCESSED FIRE LOGS AND FIRE STARTERS, OR CARDBOARD BOXES WHICH EXCEED THE VOLUME OF THE "NORMAL LOG FIRE". THESE MATERIALS PRODUCE MANY SPARKS AND MUST NOT BE USED.



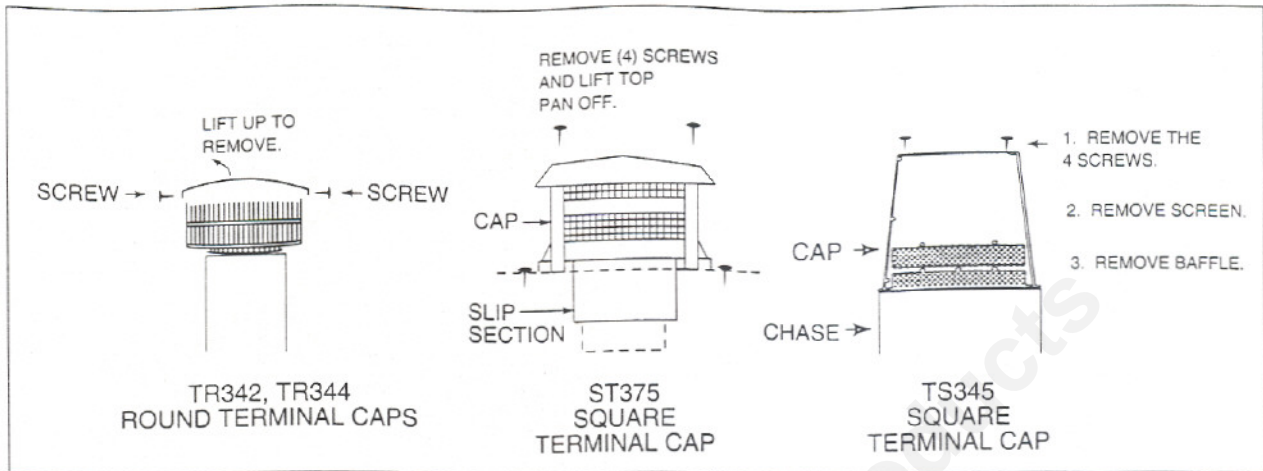

Figure 27 - Terminal Caps

WARNING!

A CHIMNEY FIRE CAN PERMANENTLY DAMAGE YOUR CHIMNEY SYSTEM. THIS DAMAGE CAN ONLY BE REPAIRED BY REPLACING THE DAMAGED COMPONENT PARTS. CHIMNEY FIRES ARE NOT COVERED BY THE LIMITED WARRANTY AND BUYER PROTECTION PLAN.

CAUTION:

WHEN LEFT CLOSED WHILE BURNING YOUR FIREPLACE, FIRESCREENS AND GLASS DOORS WILL BE HOT. HANDLE WITH CARE.

CLEAR SPACE NEAR FIREPLACE. The hearth extension must extend at least 16 inches to the front and 8 inches to the sides of the firebox opening. Combustible materials must not be stored in this area. Combustible walls perpendicular to the front of the fireplace must be at least 24" from the fireplace opening. Room furnishings such as drapes, curtains, chairs, or other combustibles must be at least 4 feet from the open front of the fireplace.

GRATE. The factory installed integral grate must be used to hold the logs from falling out of an open fireplace and to allow air to pass between the burning logs. It is important to keep the fire off the hearth and to allow the ashes to collect beneath the fire, thereby forming a layer of additional heat protection. See Figure 25. Use only model number GR8 integral grate for replacement.

FIRESCREEN. A firescreen is always provided to control sparks. It must be closed whenever the fireplace is in use. Glass doors or firescreens must not be used to hold burning material inside the fireplace. Only those glass door units specifically tested and listed for use with the specific fireplace model should be used. Screens should be closed when the glass doors are closed.

NEGATIVE AIR PRESSURE WITHIN THE STRUCTURE. This fireplace will operate correctly only if adequate ventilation is provided to allow proper draft to the fireplace system. Heatilator assumes no responsibility for the improper performance of the fireplace system caused by inadequate draft due to environmental conditions, downdrafts, tight sealing construction of the structure, or mechanical exhausting devices which create a negative air pressure within the structure where the fireplace is located.

OUTSIDE AIR KIT OPERATION. A damper control handle allows the individual control of the outside air inlets if your fireplace is equipped with this option. Use of outside air for combustion is highly recommended to conserve heated air within the structure and to provide make up air to keep the fireplace venting properly.





HEATILATOR WOODBURNING FIREPLACE 20-YEAR BUYER PROTECTION PROGRAM

Heatilator, a Division of Hearth Technologies Inc., is pleased to offer the following Buyer Protection Program ("Program"), including a 5-year Limited Warranty and a 15-year Replacement Parts Advantage, for Heatilator® woodburning fireplaces installed in the United States of America or Canada. Dealers and employees of Heatilator have no authority to make any warranty or authorize any remedies in addition to or inconsistent with the terms of this Program. This Program gives you specific legal rights. You may also have other rights which vary from state to state or within Canada.

LIMITED WARRANTY. Heatilator ("Heatilator") warrants the following components of your Heatilator® woodburning fireplaces (the "Fireplace") to be free from any original defects in material and workmanship for a period of five years from the date of initial installation, when installed in accordance with the Installation Instructions and used in accordance with the Operating Instructions: firebox assembly, chimney system and roof termination.

REPLACEMENT PARTS ADVANTAGE. Although not a warranty, during the sixth through twentieth years after the initial installation, Heatilator will provide, pursuant to its Replacement Parts Advantage, repair or replacement parts for defective components or optional components, if available, at 50% of the then current retail price. Heatilator shall have no responsibility for freight and labor charges related to such repair or replacement parts.

EXCLUSIONS AND QUALIFICATIONS. This Program applies only while the Fireplace is in its location of original installation. Heatilator's obligation under this Program does not extend to damages resulting from (1) installation, operation or maintenance of the Fireplace not in accordance with both the Installation Instructions and the Operating Instructions furnished with the Fireplace; (2) installation which does not comply with local building codes; (3) shipping, improper handling, improper operation, abuse, misuse, accident or unworkmanlike repairs; (4) inadequate ventilation or drafting caused by tight sealing construction of the structure, air handling devices such as exhaust fans or forced air furnaces, or other causes; (5) use of fuels other than those specified in the Operating Instructions; (6) installation or use of any non-Heatilator components not expressly authorized and approved by Heatilator; and/or (7) modification of the Fireplace not expressly authorized and approved by Heatilator.

THERE ARE NO IMPLIED WARRANTIES OF MERCHANTABILITY OR FITNESS FOR PARTICULAR PURPOSE.

LIMITATION OF LIABILITY. HEATILATOR'S OBLIGATION AND YOUR EXCLUSIVE REMEDY UNDER THE FIVE YEAR LIMITED WARRANTY, ANY OTHER WARRANTY EXPRESS OR IMPLIED (INCLUDING MERCHANTABILITY) OR OTHERWISE SHALL BE LIMITED TO REPLACEMENT OR REPAIR AT HEATILATOR'S SOLE OPTION OF THE FIREPLACE OR COMPONENTS; PROVIDED, HOWEVER, THAT HEATILATOR HAS NO OBLIGATION TO REPAIR OR REPLACE ANY FIREPLACE OR COMPONENTS WHERE EITHER THE FIREPLACE OR ANY COMPONENT HAS BEEN REMOVED, REPAIRED OR REPLACED PRIOR TO HEATILATOR HAVING BEEN AFFORDED THE OPPORTUNITY TO INSPECT, REPAIR OR REPLACE THE FIREPLACE OR COMPONENT. DURING THE FIRST YEAR OF THE LIMITED WARRANTY, HEATILATOR WILL, AT ITS SOLE OPTION, REPAIR OR REPLACE DEFECTIVE COMPONENTS OR OPTIONAL COMPONENTS. DURING THE SECOND THROUGH FIFTH YEARS OF THE LIMITED WARRANTY, HEATILATOR WILL PROVIDE AT NO CHARGE REPAIR OR REPLACEMENT PARTS FOR DEFECTIVE COMPONENTS OR OPTIONAL COMPONENTS, EXCLUDING THE GRATE, WIRE MESH SCREEN, FAN SYSTEM, OUTSIDE AIR SYSTEM AND GLASS DOORS, WHICH HAVE A ONE YEAR LIMITED WARRANTY, AND EXCLUDING THE REFRACTORY FIREBOX LINERS, WHICH HAVE A TWO YEAR LIMITED WARRANTY. HEATILATOR SHALL HAVE NO RESPONSIBILITY FOR FREIGHT AND LABOR CHARGES RELATED TO SUCH REPAIR OR REPLACEMENT PARTS. DURING THE SIXTH THROUGH TWENTIETH YEARS AFTER INITIAL INSTALLATION, HEATILATOR'S SOLE OBLIGATION AND YOUR EXCLUSIVE REMEDY IS AS DESCRIBED IN THE REPLACEMENT PARTS ADVANTAGE SECTION ABOVE. IN NO EVENT SHALL HEATILATOR BE RESPONSIBLE FOR ANY INCIDENTAL OR CONSEQUENTIAL DAMAGES CAUSED BY DEFECTS IN THE FIREPLACE WHETHER SUCH DAMAGE OCCURS OR IS DISCOVERED BEFORE OR AFTER REPLACEMENT OR REPAIR, AND WHETHER SUCH DAMAGE WAS CAUSED BY HEATILATOR'S NEGLIGENCE.

HOW TO OBTAIN SERVICE. To obtain service under this Program, you must:

1. Send written notice of the claimed condition to Heatilator, Technical Services Department, 1915 West Saunders Street, Mt. Pleasant, Iowa 52641.
2. Provide proof of purchase to Heatilator.
3. Provide Heatilator reasonable opportunity to investigate the claim, including reasonable opportunity to inspect the Fireplace prior to any repair or replacement work and before the Fireplace or any components of the Fireplace has been removed from the place of original installation.
4. Obtain Heatilator's consent to any warranty work before the work is done.

ADDITIONAL INFORMATION. If you would like information on current HEATILATOR products or want to locate a dealer in your area, simply call 800-843-2848.

©1995 Heatilator, a Division of Hearth Technologies Inc.