

JOTUL



Series 8

Installation and Operating Instructions



SAFETY NOTICE: IF THIS SOLID FUEL ROOM HEATER IS NOT PROPERLY INSTALLED, A HOUSE FIRE MAY RESULT. FOR YOUR SAFETY, FOLLOW THE INSTALLATION DIRECTIONS. CONTACT LOCAL BUILDING OR FIRE OFFICIALS ABOUT RESTRICTIONS AND INSTALLATION INSPECTION REQUIREMENTS IN YOUR AREA.

Tested and listed by Inchcape Testing Services-Warnock Hersey of Middleton, Wisconsin.
Tested to UL 1482, ULC S627

Report No. 13322-231

JØTUL SERIES 8

Produced by: Jøtul ASA,
Fredrikstad, Norway

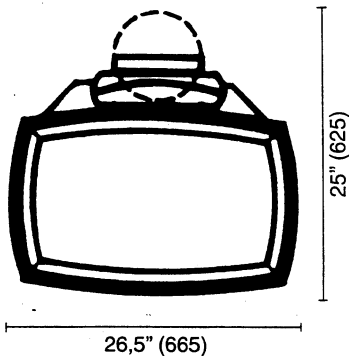
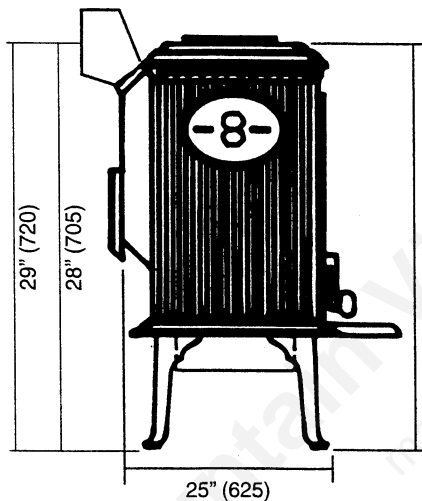
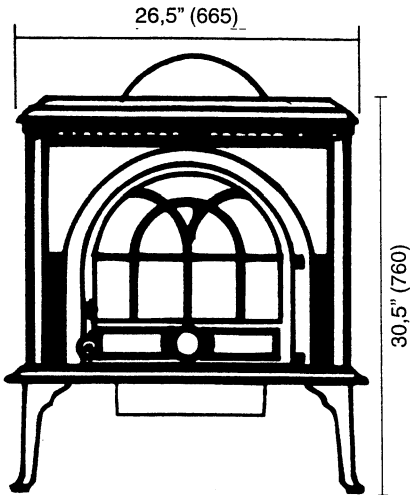

INDEX

1. General Information	1
2. Hazards Connected to the use of the Jotul Wood stove	1
3. Installation	4
Safety Notice	4
A. Chimney Connector	4
B. Thimble	
Masonry Thimble	
Listed Prefabricated Thimbles	
C. Chimneys	5
Masonry Chimneys	6
Connection to a Metal Prefabricated Chimney	7
D. Clearances to Combustibles	8
Floor Protection	9
Clearances	9
Standard Installations	9
Corner Installations	9
Installations Accesories	10
4. Assembling the Stove	10
Assembly	10
Selecting Flue Outlets	10
5. Operation	10
Wood Storage	11
Creosote and Soot Formation and the Need for Removal	11
Breaking in Your Stove	11
Building a Fire	11
A Good Foundation	12
Adjusting the Heat Output	12
Re-loading	12
Ash Removal	13
6. Catalyst	13
Catalyst Monitoring	14
Catalyst Trouble Shooting	14
Combustor Problems	14
Plugging	15
Masking	15
Cracking	15
Peeling	15
Deactivation Poisoning	15
7. Maintenance	15

1. General Information

Jøtul is the world's largest manufacturer of solid fuel burning appliances and has been making cast iron wood and coal stoves since 1853. Your new Jøtul stove has inherited the benefits learned from more than 140 years of producing stoves. With proper care and operation, your new Jøtul Stove will last many, many years.

The Owner's Manual describes the installation and operation of the Jøtul fireplace series 8 equipped wood heater. This heater meets the U.S. Environmental Protection Agency's emission limits for wood heater sold after July 1, 1990. Under specific test conditions, this heater has shown heat at rates ranging from 12,600 to 33,000 BTU's per hour.

When installing, operating, and maintaining your Jøtul fireplace stove, follow the guidelines given in these instructions. Save these instructions, and make them available to anyone using the stove.

A number of areas of the U.S. and Canada require a building permit to install a solid-fuel burning appliance. NFPA 211 (National Fire Protection Association, Standard for Chimneys, Fireplaces, Vents, and Solid-Fuel Burning Appliances) or CAN/CSA B-365 (Installation Code for Solid-Fuel Burning Appliances and equipment) may apply to the installation of solid fuel burning appliances in your area. Your Jøtul dealer has knowledge of your local codes and can provide assistance in making sure your installation is safe and legal. Also contact your insurance representative, building inspector, or fire officials to determine what regulations apply in your area.

The Jøtul series has been tested and listed to ANSI-UL 737, ANSI-UL 1482, and ULC S627 by InChape Testing Services-Warnok Hersey of Middleton, Wisconsin.

2. Hazards Connected to the use of the Jøtul Wood stove

Any use of fire in the house represents a certain danger. With intense overfiring, temperatures on the surface of the Jøtul fireplace stove can exceed 1000° degrees F (536 degrees C).

Please comply with the following warnings.

* Never overfire the stove. If any part of the stove or chimney glows, you are overfiring, and a house fire or serious damage to the house could result. Immediately close down the draft control if you notice this condition.

- Teach children that the stove is hot and should not be touched.
- Never use gasoline, gasoline-type lantern fuel, kerosene, charcoal lighter fluid or similar liquids to start or «freshen up» a fire in this heater. They can ignite with explosive force, causing bodily injury or death. Keep all such liquids far away from the heater while it is in use. Some fuel will during combustion separate Carbon Monoxide and generate it in the burnchamber. Carbon Monoxide is toxic, so please follow guidelines in this manual for reloading to avoid smoke «roll out» from the burnchamber.
- If you for some reason experience smoke «roll out» from the fireplace it might activate smoke detectors (if installed).
- Never use the stove if there are combustible gases in the house. The fumes from certain cleaning fluids, adhesives, and paints are a few examples of combustible gases. Remember, the operating woodstove is a source of open «flame».
- Avoid creating a low pressure condition in the room where the stove is operating. Operating an exhaust fan or a clothes dryer could create a low pressure area, causing poisonous gases to come out of the stove into the room. You can prevent a low pressure condition by providing adequate outside combustion air within 24" of the stove.
- Never operate the Jøtul Fireplace stove with cracked or broken glass. Replace damaged glass only with original Jøtul ceramic glass panels. Available from your dealer.
- Never burn trash of any kind in the stove.
- Keep combustible materials away from the stove.
- Never modify the stove in any way that is not in accordance with the manufacturer's specifications.
- Do not dry clothes over the stove, since they could fall and ignite.
- Use only seasoned wood in your stove. Never use fireplace coal or synthetic logs.
- Always wear protective gloves when adding fuel to the fire.
- Never operate the stove without the catalyst in place. It is a violation of federal law and could cause an overfiring condition. Do not connect this heater to any air distribution duct.
- **This stove is not approved for use in mobile homes.**

3. Installation

Safety Notice:

IF THIS FIREPLACE STOVE IS NOT PROPERLY INSTALLED, A HOUSE FIRE MAY RESULT. FOR YOUR SAFETY, FOLLOW THE INSTALLATION DIRECTIONS. CONTACT LOCAL BUILDING OR FIRE OFFICIALS ABOUT RESTRICTIONS AND INSTALLATION INSPECTION REQUIREMENTS IN YOUR AREA.

Please read this entire manual before you install and use your new stove. Failure to follow instructions may result in property damage, bodily injury, or even death.

Plan Ahead

A safe installation involves several elements including: (A) the chimney connector, (B) the chimney itself, (C) the connection between the chimney connector and chimney, and (D) protection of combustible materials in the vicinity of the stove. Each of these elements is equally important for a safe stove installation.

A. Chimney Connector (Stove Pipe)

Chimney connector is also sometimes called stove pipe or flue pipe, and it is used to connect the stove to the chimney. The chimney connector should be 6" diameter black steel, with a minimum 24 gauge thickness.

Do not use aluminum or galvanized steel pipe as a chimney connector. These materials cannot withstand the extreme temperatures of a wood fire and give off toxic fumes when heated.

Matching enamel pipe is available for your Contact your Authorized Jøtul Dealer for more information.

Do not use chimney connector pipe as a chimney.

Chimney connector sections must be attached to the stove's flue exit and to each other with the crimped end toward the stove (**Figure 2**).

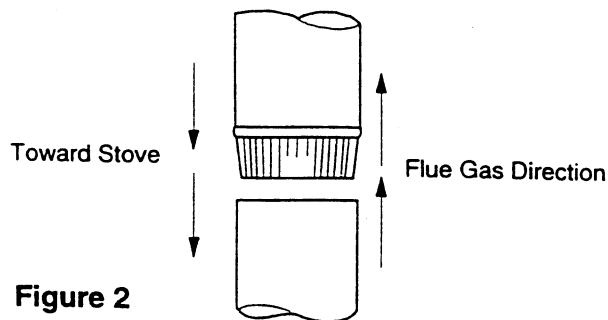

Figure 2

All joints should be secured with three sheet metal screws to ensure that the sections will not separate.

In the rear flue-exit configuration, the stove's flue exit and any attached connector pipe must be supported by either wall pass-through brackets or ceiling pass-through support brackets.

For proper operation, the chimney connector should be as short as possible. Horizontal lengths should have an upward slope from the stove of 1/4" per foot. Avoid using more than two 90-degree elbows or total runs of pipe greater than 10'.

No part of the chimney connector may pass through an attic or roof space, closet or other concealed space or through a floor or ceiling. Whenever possible, avoid passing the chimney connector through a combustible wall.

Wall Pass-Throughs

When your installation unavoidably requires that the chimney connector pass through a combustible wall to reach the chimney, extreme care must be taken. In the U.S., the National Fire Protection Association's publication NFPA 211, Standard for chimneys, Fireplaces, Vents and Solid Fuel Burning Appliances, permits four methods for passing through a combustible wall. In Canada, refer to the CAN/CGA B365. Before beginning the installation, contact local building officials to make sure the proposed pass-through method meets local building code requirements.

A commonly used method to pass through a wall directly to a masonry chimney requires removal of all combustible material from at least 12" around the entire chimney connector. The space is then filled with at least 12" of brick around a fireclay liner. Be sure to locate it so that the top of the chimney connector will be at least 18" below the ceiling. To construct the brick pass-through, you will need an opening of 30"x30" minimum. It will be necessary to cut wall studs, install headers, and construct a sill frame to maintain proper dimensions and to hold the weight of the brick. Minimum 3-1/2" (4" nominal) thick solid bricks are to be used. The fireclay liner (ASTM C35 or equivalent), minimum 5/8" wall thickness, must not penetrate into the chimney beyond the inner surface of the chimney flue liner and must be firmly cemented in place. If it is necessary to cut a hole in the chimney liner, use extreme care to keep it from shattering. Refractory mortar must be used at the junction to the chimney liner. **See Figure 3.**

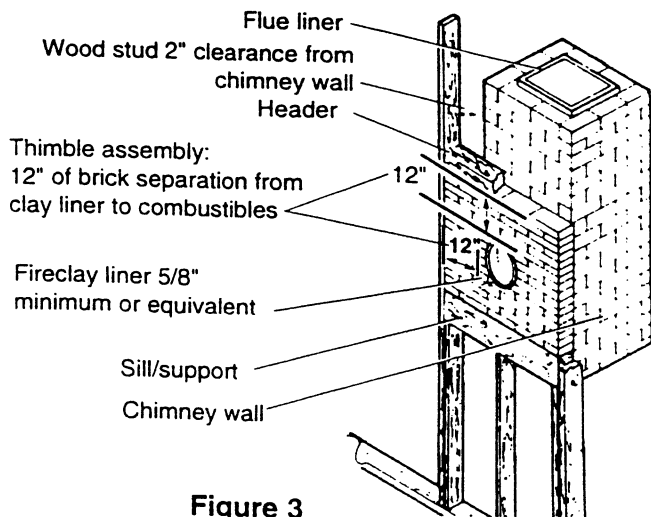

Figure 3

chimney section should never penetrate the inner flue liner.

See NFPA-211 for other approved wall pass-through methods.

C. Chimneys

There are two types of chimney suitable for Jøtul wood-burning stoves. These are either an approved masonry chimney or a listed residential type building heating appliance chimney.

When selecting a chimney type and the location for the chimney in the house, keep this in mind: it is the chimney that makes the stove work, not the stove that makes the chimney work. This is very important to remember. If you were able to set your new stove out in the yard and build a fire in it, it would be very difficult to keep the fire going without a chimney drawing air through the stove.

This is because a chimney actually creates a suction, called draft, which pulls air through the stove. There are several factors which influence drafts. Some of the major factors are: height of the chimney, cross section area, temperature of the chimney, and the location of surrounding trees or buildings. In general, a short masonry chimney on the exterior of a house will give the poorest performance, and a masonry chimney inside the house will work the best.

The exterior chimney can be very difficult to warm up, and in extreme northern areas may not work at all. On the other hand, not only is an interior chimney easier to keep warm, but its heat loss is inside rather than outside.

This guideline gives the necessary chimney requirements based on the U.S. national code (NFPA 211). However, many local codes differ from the national code to take into account climate, altitude, or other factors. It is important that you check with your local building officials to find out what codes apply in your area before constructing a chimney.

Figure 4 shows an approved installation that uses a section of listed solid fuel insulated factory-built chimney as a pass-through for the chimney connector.

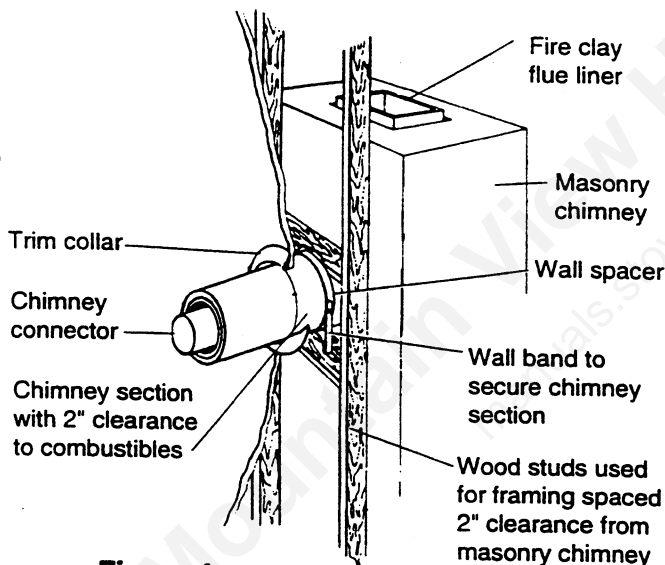

Figure 4

The chimney section must have an inside diameter which is 2" larger than the chimney connector, have a minimum length of 12" and must have at least 1" of insulation thickness. The chimney section is installed with at least 2" of air space between the outer chimney wall and adjacent combustible materials.

Sheet steel support plates are used on both ends of the chimney section to keep the connector centered. The opening around the chimney section is closed on both sides of the wall with sheet steel plates and the chimney section is securely fastened to the plates. Fasteners used to support the

Masonry Chimneys

Following is a list of the more important minimum requirements for a properly constructed masonry chimney.

- The foundation must be large enough to support the intended chimney before settling.
- The masonry wall of the chimney, if brick or modular block, must be a minimum of 4" nominal thickness. A mountain or rubble stone wall must be at least 12" thick.
- The chimney must have a fireclay flue liner (or equivalent) with a minimum thickness of 5/8" and must be installed with refractory mortar. There must be at least 1/2" air space between the flue liner and the chimney wall.
- The fireclay flue liner should measure 8"x8". If round fireclay liners are used, the inside diameter must be 6". If an existing chimney with larger tiles is used, it should be relined with an appropriate liner.
- No other appliance can be vented into the same flue.
- An airtight cleanout door should be located at the base of the chimney.
- A chimney inside the house must have at least 2" of clearance to the combustible structure. A chimney outside the house must have at least 1" clearance to the combustible structure. Fire stops must be installed at the spaces where the chimney passes through floors and/or ceilings (Figure 5).

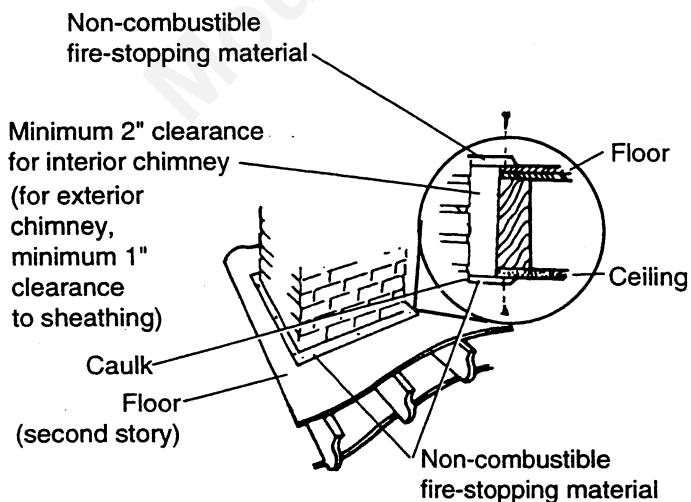

Figure 5

Remember that there must be air space around the chimney and that insulation must be 2" more from the chimney (Figure 6)

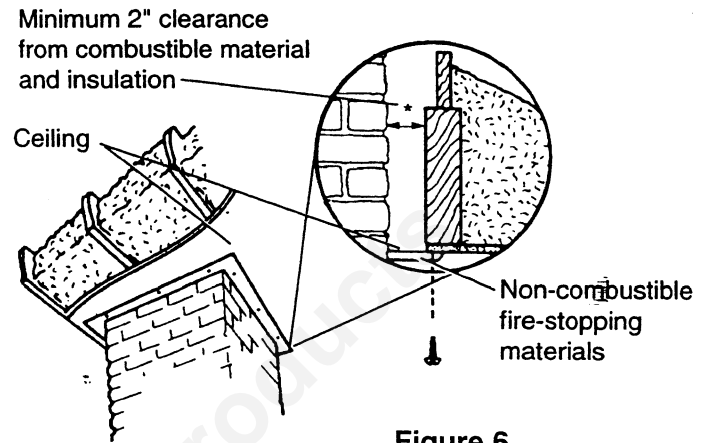

Figure 6

- A chimney must be the required height above the roof or other obstruction for safety and for proper draft operation. The requirement is that the chimney must be at least 3' higher than the highest point where it passes through the roof and at least 2' higher than the highest part of the roof or structure that is within 10' of the chimney, measured horizontally (Figure 7).

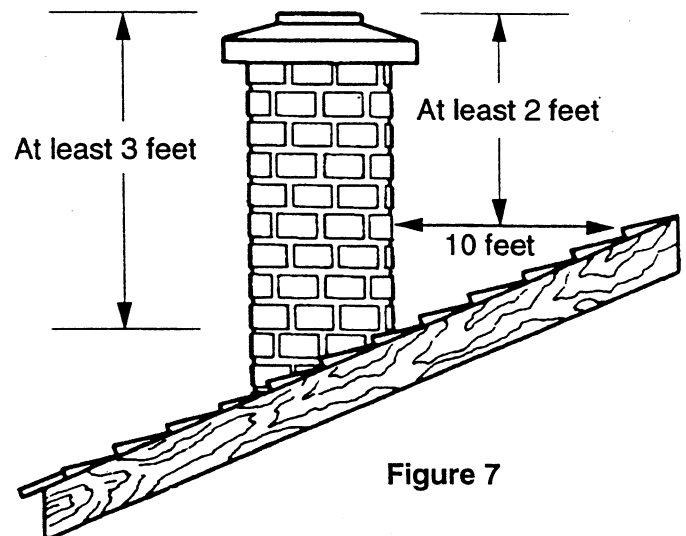

Figure 7

Chimneys shorter than 14' may not provide adequate draft. This could result in smoke spilling into the room from the door or joints in the stove or pipe. In addition, inadequate draft can cause back puffing or catalyst plugging. Too strong a draft, on the other hand, can cause excessive temperatures, damage the catalyst, and shorten burn times.

Excessive drafts can be corrected by having your dealer install a barometric damper set at 0.1" of water column. If you suspect your draft is inadequate, consult your dealer.

Connection to a Metal Prefabricated Chimney

The heater must be connected to a listed Type HT per UL 103 or ULC S629 prefabricated chimney. When a metal prefabricated chimney is used, the manufacturer's installation instructions must be followed precisely. You must also purchase (from the same manufacturer) and install the ceiling support package or wall pass trough, "T" section package, firestops (when needed), insulation shield, roof flashing, chimney cap, etc. Maintain the proper clearance to the structure as recommended by the manufacturer. This clearance is usually a minimum of 2" although it may vary by manufacturer or for certain components.

There are basically two methods of metal chimney installation. One method is to install the chimney inside the residence through the ceiling and the roof (Figures 8, 9). The other method is to install an exterior chimney that runs up the outside of the residence (Figures 10, 11). The components illustrated may not look exactly like the system you

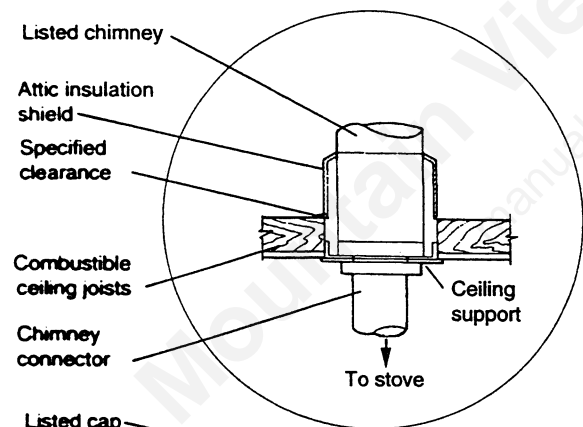

Figure 8

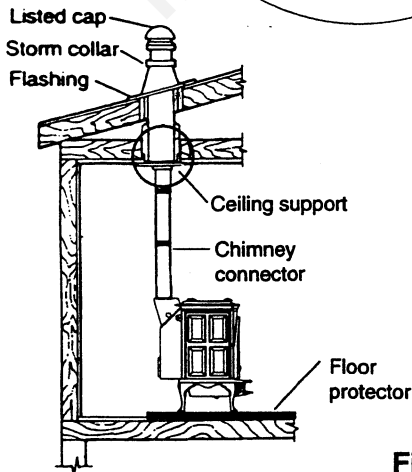

Figure 9

purchase, but they demonstrate the basic components you will need for a proper and safe installation.

The chimney must be the required height above the roof or other obstruction for safety and proper draft operation (Figure 7).

REMEMBER: Follow the manufacturer's installations instructions and maintain the manufacturers's specified clearance distances.

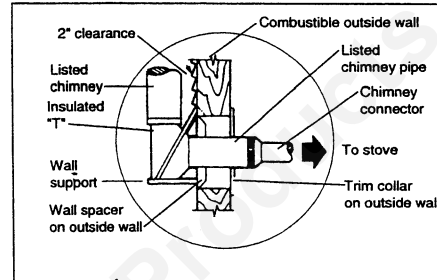

Figure 10

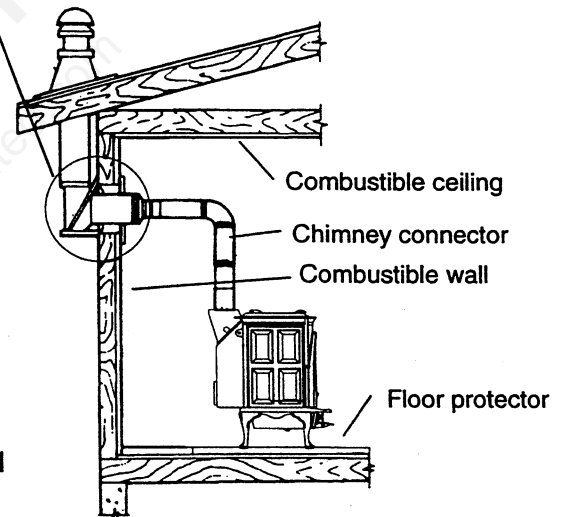

Figure 11

Masonry Chimneys

When connecting to a masonry chimney, the chimney connector must slide completely inside the chimney thimble (or breach) to the inner surface of flue liner. Make sure the connector does not protrude past the inside of the flue liner as that will reduce the flow area available for the smoke and ultimately cause problems with your chimney system. The chimney connector should be sealed into thimble with refractory cement and the connector should also be mechanically fastened to the chimney. See Figure

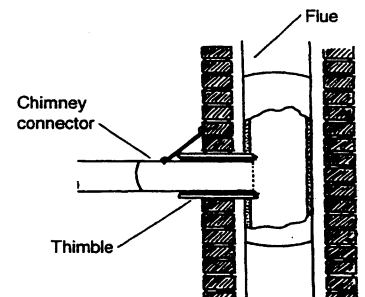

Figure 12

Through a Masonry Fireplace

The Series 8 may be vented through a masonry fireplace. The fireplace opening height must be at least 31".

The damper plate must be either removed or securely fixed in the open position, and the damper opening around the connector sealed with sheetmetal and sealant. The connector must extend above the tile liner. See **Figure**.

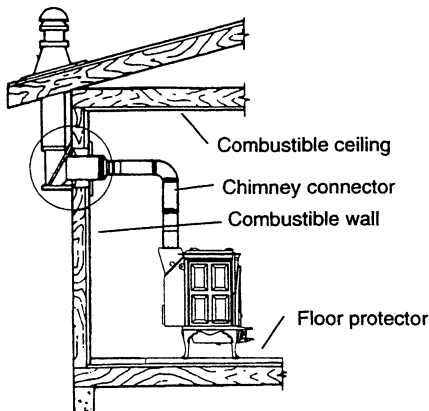

Figure 13

The chimney flue size must not exceed three times the cross sectional area of the stove's flue. If the flue is larger than this, an approved chimney relining system should be installed to downsize the flue.

Fireplace installations must observe special clearance requirements to surrounding trim and the mantel as illustrated in **Figure**.

Alternate Floor Protection

All floor protection materials must be non-combustible (i.e., metals, brick, stone, mineral fiber boards, etc.). Any organic materials (i.e., plastics, wood, paper products, etc.) are combustible and must not be used.

The floor protector specified may include some form of thermal designation such as R-value (thermal resistance), k-factor (thermal conductance).

The easiest means of determining if a proposed alternate floor material meets requirements listed in the appliance manual is to follow this procedure:

1. Convert the specification to R- value.
 - a. If R- value is given, no conversion is needed.
 - b. k- factor is given with a required thickness (T) in inches: $R=1/kXT$.
 - c. C-factor is given: $R=1/C$
2. Determine the R-value of the proposed alternate floor protector.

- a. Use the formula Step 1 to convert values not expressed as "R".
- b. For multiple layers, add R-values of each layer to determine overall R-value

3. If the overall R-value of the system is greater than the R-value of the specified floor protector, the alternate is acceptable.

EXAMPLE:

The specified floor protector should be 3/4 inch thick material with a k-factor of .84. The proposed alternate is 4" brick with a C- factor of 1.25 over 1/8" mineral board with a k-factor of .29.

Step A. Use formula above to convert specifications to R-value. $R = 1/k \times T = 1/.84 \times .75 = .893$

Step B. Calculate R of proposed system.

4" brick of C-.1.25,
therefor $R_{brick} = 1/C = 1/1.25 = .80$.

1/8" mineral board of $k=.29$,
therefor $R_{min. bd.} = 1/.29 \times .125 = .431$.

Total R $R_{brick} R_{mineral board} = .8 + .431 = 1.231$.

Step C. Compare proposed system R of 1.231 to specified R of .893. Since R is greater than required, the system is acceptable.

D. Clearances to Combustibles

Definitions:

$$\text{Thermal conductance} = C = \frac{\text{Btu}}{(\text{hr})(\text{ft}^2)(\text{°F})} = \frac{W}{(\text{m}^2)(\text{°K})}$$

$$\text{Thermal conductivity} = k = \frac{(\text{Btu})(\text{inch})}{(\text{hr})(\text{ft}^2)(\text{°F})} = \frac{W}{(\text{m})(\text{°K})} = \frac{(\text{Btu})}{(\text{hr})(\text{ft}^2)(\text{°F})}$$

$$\text{Thermal resistance} = R = \frac{(\text{ft}^2)(\text{hr})(\text{°F})}{\text{Btu}} = \frac{(\text{m}^2)(\text{°K})}{W} = \frac{(\text{Btu})(\text{inch})}{(\text{hr})(\text{ft}^2)(\text{°F})}$$

D. Clearances to Combustibles

Good planning for stove placement involves more than just insuring you have adequately protected combustible materials. It should also consider your comfort and convenience.

NOTE: THE CLEARANCES EXPRESSED IN INCHES ARE THOSE APPROVED FOR INSTALLATIONS IN THE UNITED STATES. THE CLEARANCES IN PARENTHESES THAT ARE EXPRESSED IN MILLIMETERS ARE THOSE APPROVED FOR INSTALLATIONS IN CANADA. DIFFERENT TEST STANDARDS FOR THE RESPECTIVE COUNTRIES MAY RESULT IN DIFFERENCES IN THE CLEARANCE REQUIREMENTS.

The radiant heat from your stove will warm its surroundings and, in turn, the air. Will the warm air from the stove freely rise and migrate to other areas of the house? Will the stove and hearth interrupt with or disturb traffic patterns in the home? Is it convenient to bring wood to the stove? These are but a few of the questions you will want to ask when choosing a site for your stove.

A simple way to visualize the area required by the stove is to cut out a piece of newspaper the same size as the stove (25.5x18"). Place the newspaper on the floor and select the appropriate dimensions from the following sections on floor and wall protection.

Floor protection

Your stove must be placed on a non-combustible surface with a minimum R value of .45 which extends 8" beyond the sides and back of the stove and 18" in the front of the stove. This will result in an overall base which is 41.5" wide x 44" deep (Figure 12A). This is the minimum floor protector size. Floor protection must also be used under the stove pipe and extend 2" beyond either side of the pipe (12B).

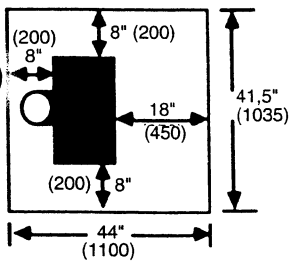

Figure 13A

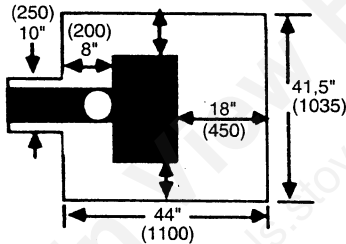

Figure 13B

A number of pre-manufactured floor protectors are also available. If you choose to use one of these, make sure that it has a safety listing mark on it. Never put any type of floor protection on top of carpeting.

Clearances

Safe distances must be maintained between the stove and combustible materials in its vicinity. A combustible is anything that can burn; and in the case of stove installations, these combustibles may not be visible. If you are not sure of the combustible nature of any material in the vicinity of your planned stove installation, you should check with your local fire officials. Remember that "fire resistant" materials are considered combustible: They are difficult to ignite, but they will burn.

If you have recently purchased a home which has a stove hearth in it that you plan to use, it is extremely important that the entire system is examined for safety. Many older homes have faulty chimneys, or previous owners may have covered combustible walls or studs with brick veneers. Heat is easily conducted through brick and could ignite unseen combustible behind it. Contact local building or fire officials about restrictions and installation requirements in your area.

Standard installations

Figure 13 gives clearances to combustible walls for the Jotul Series 8. The rear clearance is 19.5" (50cm) from the flue outlet or 28 inches from the stove top.

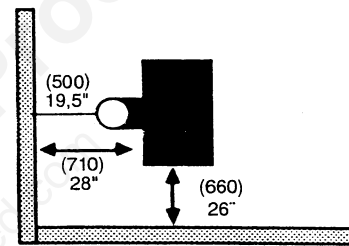

Figure 14

•Clearances behind the stove can be reduced from 28" to 18" by using the Jøtul heat shield, part #950076, and double wall air insulated chimney connector.

Corner installations

Figure 14 shows the clearances to combustible walls in a corner installation. The measurements are taken from the stove top.

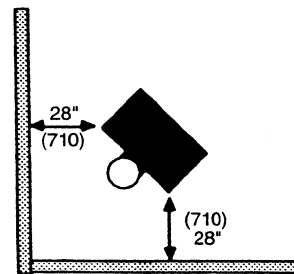

Figure 15

•Corner clearances can be reduced to 18" (460 mm) using Jotul heat shield part #950076.

Masonry fireplace installations require the use of the fireplace shield (Part 350073)

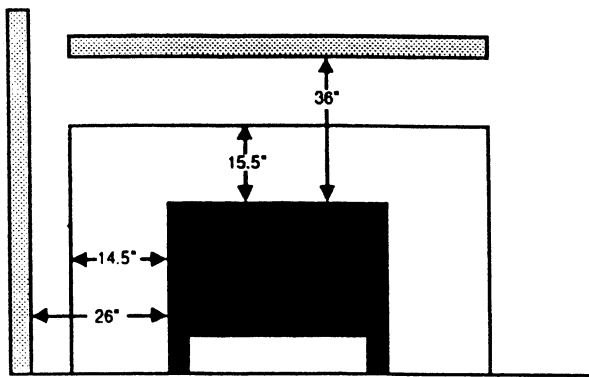

Figure 16

Installation Accessories

Several manufacturers have developed installation accessories for wood and coal stoves. These accessories are generally intended to reduce the required clearances we have established during testing. If you choose to use any of these accessories, make sure they have been tested by an independent laboratory and carry that laboratory's testing mark. Make sure that the manufacturer's directions are followed.

The National Fire Protecting Agency (N. F. P. A.) also publishes guidelines in their code, N. F. P. A. 211, for the construction of clearance reduction systems if you care to make your own floor and wall protectors. Your dealer should be able to explain N. F. P. A. 211 to you.

4. Assembling the stove

In order to prevent shipping damage, several parts of your stove have been removed and packed separately. These parts are:

- 4-legs
- 1-bottom heat shield
- 1-ash/log retainer
- 1-ash lip
- 1-door handle
- 1-Flue outlet

Assembly

1. Lift the top of the stove and with someone's help, gently lay the stove on its back
2. Attach the legs using the four 6x25mm hex bolts and square washers. Attach the bottom heat shield with the 6x16mm bolt. The two channels which hold the optional door screen should face the floor.

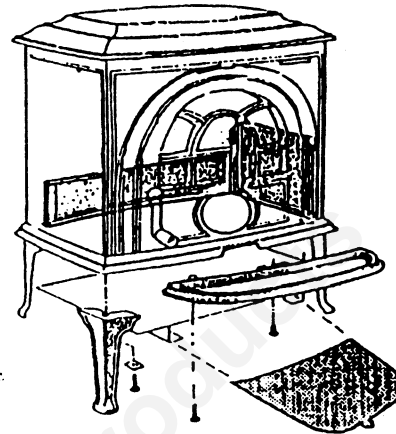
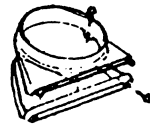

3. Stand the stove up and bolt on the ash lip with a 6x16mm bolt.
4. Set the ash/log retainer into the front of the stove.
5. Place the insulated washer between the wooden knob and the door handle. Insert the long screw through the wooden knob and screw it into the handle.

Selecting Flue Outlets

The Jøtul Series 8 has reversible flue outlet. To reverse outlet directions reach inside the outlet and unbolt the two bolts which hold the two halves together. This allows access to the two bolts which hold the back half of the outlet to the stove body. Unbolt the back half, remove it and turn it over to change positions. Re-bolt the back half into place and then put the front half back on with the two bolts.

Note:

BE SURE THAT THE BOLTS THAT THE OUTLET TO THE STOVE ARE INSTALLED WITH THE HEX HEAD DOWN AND THE THREADS GOING UP. REVERSAL OF THESE BOLTS MAY RESULT IN BINDING OF THE DAMPER.

5. Operation

Before building a fire in your new stove, please read the following section carefully.

This stove is designed to burn natural wood only. Higher efficiency and lower emissions generally results when burning air-dried seasoned hardwoods, as compared to softwoods or to green or freshly-cut hardwoods.

Do Not Burn;

- Coal
- Garbage
- Cardboard
- Solvents
- Treated or Painted Wood
- Chemical Chimney Cleaners
- Colored Paper
- Trash

Burning treated wood, garbage solvents, colored paper, chemical chimney cleaners, or trash may result in release of toxic fumes and may poison or render ineffective catalytic combustor.

Burning coal, cardboard, or loose paper can produce soot or large flakes of char or fly ash that can coat the combustor, causing smoke spillage into the room and rendering the combustor ineffective.

Never use gasoline, gasoline type lantern fuel, kerosene charcoal lighter fluid, or similar liquids to start or "freshen up" a fire in this heater. Keep all such liquids far away from the heater while it is in use.

HOT WHILE IN OPERATION. KEEP CHILDREN, CLOTHING AND FURNITURE AWAY. DO NOT STORE FUEL WITHIN THE CLEARANCES LISTED PREVIOUSLY.

Wood storage

When storing wood outside, it should be covered and stored off the ground to protect it from the elements. Make certain that the woodpile has good air circulation through it in order to promote drying to aid in the seasoning process.

To obtain the most benefit from the wood you burn, use only seasoned wood which has been cut and split for at least one year. Burning unseasoned or wet wood causes rapid development of creosote, while reducing the heat value of the wood being burned.

Creosote and Soot Formation And The Need For Removal

When Wood is burned slowly, it produces tar and other organic vapors which combine with expelled moisture to form creosote. These creosote vapors condense in the relatively cool chimney flue a slow-burning fire. The creosote that accumulates in the flue is highly flammable and is the fuel of chimney fires. To prevent a chimney fire, the creosote needs to be removed by sweeping the chimney and flue connector. The frequency of sweeping will depend on how you operate your stove, but it is important to inspect the flue after every two weeks of use. An accumulation of 1/4" or more on the sides of the flue

or connector is considered hazardous and should be removed.

In the event that creosote in your chimney or flue connector ignites, the resulting fire is often accompanied by a roaring noise and a crackling sound as flakes of burned creosote break loose. If you suspect you are having a chimney fire, immediately close the draft regulator and make sure the stove door is closed. Call the fire department and get everyone safely out of the house.

Trying to extinguish the fire in the stove will not help. In fact, it can make the matter worse by allowing oxygen through the door, which then supports the fire in the chimney. When the roaring and crackling have stopped, you should resist the temptation to open the door and look at the fire. The fire may have suffocated, but could rekindle when you open the door. After a chimney fire, do not use your stove until the chimney and the flue connector have been cleaned and inspected to ensure that no damage has been sustained.

Breaking in your stove

A cast iron stove should be "broken in" the same way a new car with a cast iron engine is: gradually. It is mandatory that five consecutive small fires are built in the stove prior to operating the stove continuously. Each fire should be a little larger than the previous one, and the last fire should be a full-sized load. Allow the stove to cool completely between fires. Breaking in your stove this way works much like an athlete limbering up before competing.

Painted stoves and pipe typically smoke during the first firings. This smoking is the result of the paint curing and you should provide plenty of ventilation to the room when first firing a new painted stove.

Do not start your break-in fires until you have finished reading this entire manual. Save the ashes from your break in fires. The value of those ashes in maintaining a good fire will be pointed out later.

Building a Fire.

Building a fire is actually a very good description of what you want to do. Anyone can make a fire, but when you really know what you are doing, you build a fire. Like anything else that is built, the quality of materials and the care exercised is reflected in the final product.

A good fire will efficiently utilize your fuel, keep the glass in the door clean, keep emissions and creosote to an absolute minimum, require less work, and be very predictable.

A Good Foundation

The first step in building a fire --often overlooked --is to start the fire on a good 1"-2" bed of ash. We are unable to provide ashes with a new stove, but you can generate ashes with your break in fires, covered earlier. The only time to remove all of the ashes from your stove is at the end of heating season; the rest of the time you should keep a few inches in the bottom of the stove.

Open the load door and cover the bottom of the stove with tightly crumpled newspaper. Criss-cross a generous double handful of kindling on top of the paper. Don't skimp on the kindling, its role is very important. Split pieces of scrap lumber work very well. If you don't have scrap lumber, split some of your best wood down to 1/2" thick and use that. Place three or four small pieces of wood on top of the kindling.

Before lighting the paper, open draft control, by sliding it to the right, and open the by-pass damper. To open the by-pass, fit the removable handle into the end of the by-pass control rod and pull it out.

Light the paper evenly across the front and close the door-- but not completely. If you leave your door ajar about 1/2", it causes air to race through the crack and bellow the fire. **UNDER NO CIRCUMSTANCES SHOULD YOU LEAVE THE STOVE UNATTENDED WHILE THE DOOR IS AJAR.** After three to five minutes the kindling should be forming coals and the small pieces of wood should be blackened over. The wood will have also settled and you should add more wood at this point to even out the load. Try to arrange it so that there is even space between the pieces. Give the fire about another minute with the door ajar to get the new wood caught on.

Close the door, leave the draft open completely, and close the by-pass damper. You are now at a critical stage. Until now large amounts of air have been flowing between the glass and the fire, and the glass has stayed clear since the smoke has been prevented from contacting the glass. There may just be a small stain on the lower right hand corner of the glass because of currents created in the stove when the door was cracked.

The air flow between the glass and the fire now comes from the top of the stove and falls all across the glass. The amount of air is greatly reduced and you have to take care to keep the smoke off the glass. Smoke won't deposit on a hot glass, so a lot of your efforts at quickly establishing a hot fire have helped to get the glass hot. Also, the closer you place the wood, which is cold, to the glass, the more problems you will have.

If the fire dies out and the stove fills with smoke when you close the door, you have not allowed the wood to catch on well enough. It could be that you didn't use enough kindling, used pieces that are too large or too green, or simply rushed things. It is perfectly normal for the fire to slow down when you close the door. What is not normal is for the stove to fill with so much smoke that it looks like water flowing over a dam.

If you've made it to this point, you are well on your way to becoming an expert.. You may experience a little more staining on the glass in the next few minutes until the stove gets hot. If the glass gets very dirty, there is a very good chance that your wood is green or that your chimney is not providing a strong enough pull. If you suspect a problem with your chimney, seek the advice of your dealer.

Adjusting the Heat Output

Until now, you've been operating the stove with the draft fully open. Once you have established a good bed of coals and the load of wood in the stove is burning well, you can put the draft back. The more you move it to the left, the slower and cooler the stove will burn. If you are planning to reduce the combustion significantly, it is best to cut it back in a few increments rather than all at once. At minimum draft setting, the amount of air entering the stove will be so small that it may be difficult to keep the glass clean. As long as there is a good bed of coals in the stove, it is possible to return to a hot fire and stained glass will clean itself.

Reloading

The stove is ready for re-loading when the wood has burned down to a bed of coals a few inches deep. **REMEMBER TO OPEN THE BY-PASS DAMPER BEFORE OPENING THE LOAD DOOR.** Stir the coal bed with a poker and move the hottest coals to the front of the stove. Depending on how your wood is split, you will be adding three to five pieces of wood. Select the smaller of these pieces for bottom layer of wood and space the larger pieces evenly on top of them.

If your wood is well seasoned, you have a good bed of coals, and your chimney is drawing well you can close the door, open the draft wide, and close the by-pass damper. Give the stove 10 to 15 minutes on maximum draft to allow the new load to catch on before decreasing your draft setting.

If any of your conditions are less than ideal, you may need to operate with the door ajar a few minutes after re-loading. If your coal bed has died away down, add more kindling to it before adding your fuel load.

You'll find as time goes on that the amount of time it takes to get a new load caught on will depend on the weather. It may take twice as long on muggy nights and only half as long on clears, cold nights.

Ash Removal

Ash removal will be required every day or two during normal operation, and is most easily done when the fire has burned down to coals.

First, use a stove shovel or a similar tool to move ashes in the bottom of the stove so that they fall down into the ashpan.

To remove the ashpan, locate the ashdoor under the ashlip. (**Figure 21**).

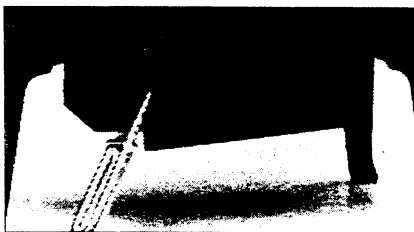

Figure 21

Use the multi-purpose handle and rotate the ashdoor clockwise to open the door. Then, insert the pin on the multi-purpose handle into the socket on the ashpan and slide the ashpan carefully from the stove. (**Figure 22**)

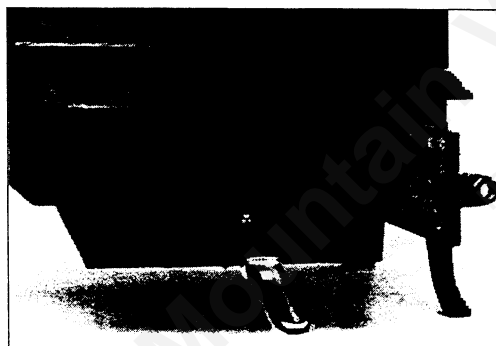

Figure 22

When removing ash from a stove that is in operating, close and latch the door before taking the ashes outside for safe disposal. It is always a good idea to wear heavy protective gloves while removing and disposing of the ashes from your stove.

Bypass catalyst prior to loading ashes. **Failure to bypass catalyst while opening a closing ash door could result in external combustion gases if top door opened shortly afterwards.**

Ashes should be placed in a metal container used exclusively for ashes, with a tight fitting lid. The closed container of ashes should be placed outdoors well away from all combustible materials,

pending final disposal. If the ashes are disposed of by burial in soil or otherwise dispersed, they should be retained in the closed container until all cinders have thoroughly cooled.

6. Catalyst

This wood heater contains a catalytic combustor, which needs periodic inspection and replacement for proper operation. It is against the law to operate this wood heater in a manner inconsistent with the operating instructions in this manual or if the catalytic element is deactivated or removed.

The catalyst in your stove is a Corning Long Life catalytic combustor, which helps the stove achieve its high efficiency rating. A separate warranty and information card is supplied by Corning with this stove. Please be sure to read the card and submit the catalyst warranty information to Corning.

A Catalyst is defined as a substance which promotes or initiates a reaction at a much lower energy level than would normally be required for the same reaction if the catalyst were not present. Furthermore the catalyst is not used up in the reaction. It is helpful when trying to understand catalytic reactions to think of the catalyst as a bridge. How much energy would it take to jump all the way across a river versus walking across a bridge? When you walk across the bridge, you use much less energy, and when you get to the other side, the bridge is still there. It hasn't been used up, and it continues to provide the same service.

Chances are, you have a catalyst in your home already, although you may not be aware of it. Self-cleaning ovens have catalysts very similar to the one in your stove. On the self-cleaning cycle, your oven gets very hot to burn off the spilled food. Normally, this would produce a lot of smoke, but by putting the smoke through a catalyst, the smoke is also burned up. Usually, this combustion is so complete you don't even realize that it has happened at all. A Catalyst coated ceramic honeycomb is located directly below the flue outlet. This catalyst reduces the temperatures necessary to ignite the gases and smoke given off as the wood is burning. Normally, these gases require a temperature of 1,100-1,200° F to burn, but the catalyst allows these gases to burn at a much lower temperature of 500-700°F.

The burning of gases in the honeycomb releases a lot of energy which would normally be lost up the chimney. Tars and resins in the smoke are also burned, which helps keep your chimney and the environment clean. In general, catalytic combustion

is pretty straightforward. Once the stove and gases have been warmed to the 500 - 700 °F range, any gases reaching the catalyst will ignite. Following the start up procedures outlined in "Building a Fire" should ensure that the catalyst and stove are adequately warmed. Once the catalytic combustor starts working, heat generated in it by burning the smoke will keep it working, even when temperatures on the stove fall below 500°F . The most important thing, then, is to get the stove and catalyst up to operating temperatures before setting the output back.

Several things could cause the catalyst to fall below its operating temperature, however. The most likely time for this to occur is during refueling. Twenty or more pounds of cold wood plus the room air entering the stove during refueling can dramatically lower the catalyst temperature. It is very important whenever reloading to allow the stove to burn hot for 10 to 15 minutes. This reheats the stove as well as raises the catalyst temperature. Getting your new load of wood burning well also helps keep the glass in the door clean.

At the end of a burn cycle, when all the wood has been reduced to charcoal, very little gas is being generated, and the catalyst can also fall below its operating temperature. Try to time your reloading so that there are enough coals left to get your new load going hot to relight the catalyst.

Catalyst Monitoring

It is important to periodically monitor the operation of the catalytic combustor to ensure that it is functioning properly, and to determine if it needs to be replaced. A non-functioning combustor will result in a loss of heating efficiency and an increase in creosote and emissions. To monitor the catalyst's performance, you can obtain a probe thermometer from your dealer, or you can observe the amount of smoke coming from your chimney.

If you have followed the start up procedures correctly and have sufficiently warmed the stove and catalyst, you should notice very little, if any, smoke coming from your chimney. Be sure not to confuse condensing steam from wet wood with smoke. Smoke gradually becomes thinner as it leaves the chimney, whereas setam travels a few feet and then vanishes.

If you purchased a probe thermometer from your Jøtul dealer, follow the directions supplied with it. With a probe thermometer you should be able to make the following observations: temperatures should be in excess of 500°F and will often exceed

1,000°F . Temperatures will drop sharply when new fuel is added, but should return to normal once the wood is burning well.

Brief periods of high temperatures are not harmful to the catalyst, but you should avoid operating the catalyst above 1,800°F. Temperatures of this magnitude can reduce the life of the catalyst and are the result of too much smoke reaching the catalyst. Finely slit wood, pitchy pine, or tightly packed loads can overwork the catalyst. It is best to use wood that is 4"-7" in diameter and to load the stove frequently with medium-sized loads.

If temperatures are above 1,800°F, they can be reduced by opening the draft control wider. Here's how it works. A large load of wood burning slowly generates a lot of gas. Since the stove is relatively cool, these gases will not burn in the stove, but will go directly to the catalyst where they will burn vigorously . Opening the draft wider allows these gases to burn in the combustion chamber, thereby reducing the total amount of unburned gases reaching the catalyst. If opening the draft fails to lower the catalyst temperature, open the load door wide to allow cold room air to cool the stove and catalyst.

Catalyst Trouble Shooting

A properly operating catalyst can improve wood stove performance in the following ways:

- Increase heat output by 50 %
- Reduce creosote formation and emissions by 90%

For these reasons you will want to make sure your catalyst is working and know what to do if it is not.

You should allow your stove to go out and visually inspect the catalyst at least three times a year.

To inspect the catalyst, unbolt the four 10mm nuts from the catalyst inspection plate on the rear of the stove. Carefully slide the catalyst out just far enough to visually check it. If the catalyst needs to be removed take care not to destroy the insulation around it. The insulation must be re-wrapped around the catalyst when it is returned to the stove.

Combustor Problems

The catalyst can be plugged with char, fly ash, or creosote. Burning garbage , cardboard , or wrapping paper produces excessive amounts of char and ash.

Creosote plugging occurs when burning wet or pitchy wood or large loads of wood on very low draft settings without allowing the catalyst to properly warm up and initiate burning. In general, creosote will not form on hot surfaces.

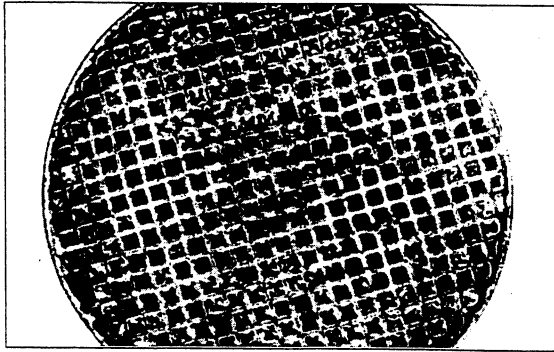

• **Plugging** (figure 16)

If the catalyst is plugged, it could also indicate that creosote has built up in your chimney and needs cleaning.

A plugged catalyst can be cleaned with a good hot fire, much in the same way that a hot fire cleans up creosote stains on the stove window. Under no circumstances should you attempt to burn out a plugged catalyst unless you are sure your chimney is clean.

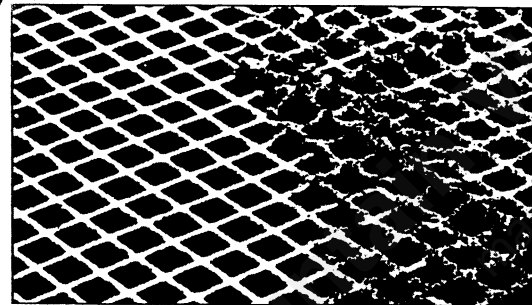

• **Masking** (Figure 17)

This is a build-up of a very fine fly ash which coats the surface of the catalyst and prevents it from coming into contact with the smoke. Fly ash can be brushed off with a soft bristled brush or vacuumed away.

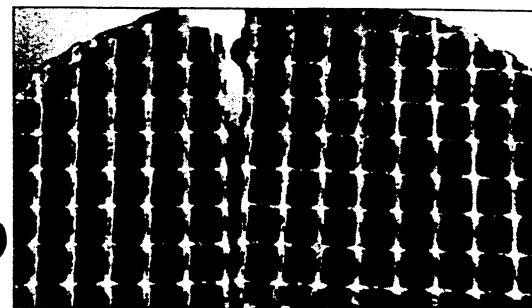

• **Cracking** (Figure 18)

Cracks can develop from either thermal stress or mechanical stress. As long as large pieces do not fall out of the combustor, it can still function with a few cracks. Mechanical stress may indicate that some part of the surrounding housing has warped and needs to be replaced.

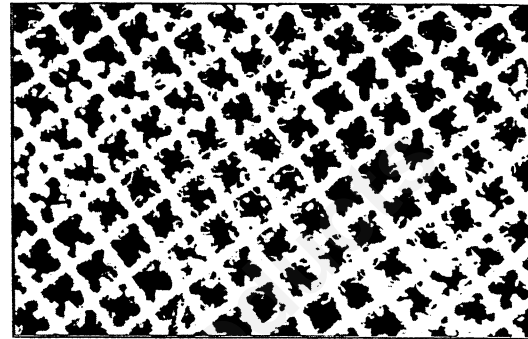

• **Peeling** (Figure 19)

Temperatures above 1,800°F and prolonged flame impingement can cause the catalyst coating to peel off the ceramic substrate. If the peeling is severe, the catalyst should be replaced.

• **Deactivation or Poisoning**

If the catalyst is intact and is clean, but fails to operate, it has probably become poisoned from chemicals in pressure treated wood or painted lumber or trash. Deactivated catalysts should be replaced.

7. Maintenance

At least once a year, you should preform a routine maintenance check. A good time to do this is when you are cleaning the chimney and the connector, Of course you should clean the chimney an connector whenever accumulations of soot and creosote reach 1/4" thick, which may be several times a year, depending on how the stove is operated.

Thoroughly clean the entire stove. Enameled surfaces can be wiped clean with soap and water. Brush all soot and ash out of the stove. It is better to brush out the ash and soot than to vacuum it out because soot particles are small enough to pass through most vacuum bags.

In a dark room, use a strong light to inspect the stove inside and out for cracks or leaks at corners and joints. Cracked parts should be replaced. Leaks at joints can be patched with stove furnace cement.

Check both door gaskets and window gaskets for tightness. To check the door gaskets put a dollar bill

half way into the stove, close the door and try pulling the dollar out. If it can be easily removed, the seal is too loose. Check several spots around the door.

The gasket between the glass and the door receives very little wear. The best indication that it needs to be replaced is streaks on the glass caused by air leaking around the gasket.

To replace the gaskets, lift the door off the stove and lay it flat. Scrape out all old gasket material and gasket cement. The gaskets are made of glass and ceramic fibers and contain no asbestos. Run a bead of stove cement into the gasket channel and press the new gasket into place. The door gasket is 56 inches long by 3/8 inches in diameter. The window gasket is 44 inches long by 3/16 inches in diameter.

The smoke by-pass opening is gasketed and this gasket should be periodically checked. The by-pass damper is gasketed and this gasket should also be checked for wear. The gasket is 37" long by 1/4" diameter. To replace the gasket, open the by-pass, remove the flue outlet and work through the outlet opening. Stuff a rag over the top of the catalyst before removing the gasket to prevent debris from falling into the catalyst.

At the end of the heating season, remove all of the ashes from the stove and spray the interior with a light coating of oil inhibit rust during the summer.

Glass Replacements

To prevent cracking of the glass operate the doors gently. Do not shut the doors by striking or slamming.

If the stove's glass is cracked or broken, you must replace it before operating your stove. Carefully remove any broken pieces. Replace the panel(s) only with Jøtul replacements, do not use substitutes.

The glass can be replaced with the door still mounted to the stove or the door hinge can be removed and the door placed on a flat working surface. The steps are the same. Carefully remove all broken glass, gasket material, fasteners and clips. Clean of all cement and residual gasket

material from the door using a wire brush. Apply a small bead of cement and the new gasket. Trim off any excess gasket length as it is important the ends meet closely but should not overlap. Center the replacement glass panel on the gasket and reinstall the glass clips and screws. It is extremely important that the retainer clips be tightened a small amount at a time and following a pattern similar to tightening the lug bolts on an automobile wheel. The clips should end up equally tightened and not over-tightened. Make sure that the glass panel stays centered in the opening and does not slip down. It may be necessary to retighten once again after the stove has been burned and the new gasket has been seated. See **Figure 27**.

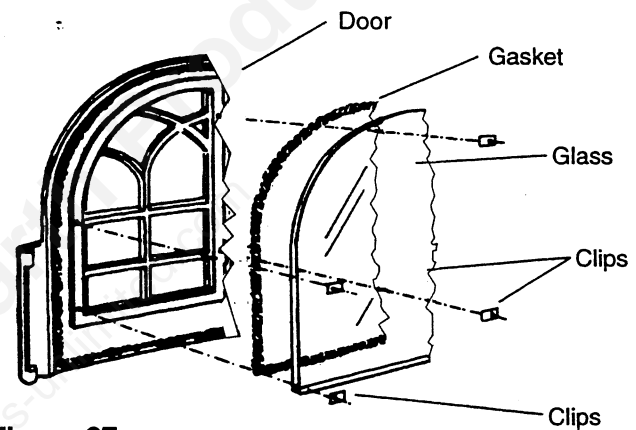

Figure 27

Glass cleaning

From time to time, clean off the accumulated ash from the inside surfaces of the glass panels. If this fly ash is allowed to remain on the surface for extended periods, it could eventually cause the glass will burn off during the next hot fire.

Never clean the glass while hot and never use any abrasive materials to clean the glass. Cool water and a soft cloth or paper towel are usually all that is required. Rinse thoroughly with clean water after washing and dry completely before burning your stove.

*Jøtul arbejder kontinuerlig for om mulig å forbedre produktene og forbeholder seg retten til å endre spesifikasjoner og utstyr uten foregående varsel.
As Jøtul continuously work to improve the products, we reserve the right to alter specifications, colours and equipment without previous notice.*

Cat. no. 128764 Oktober -97

JØTUL[®]

Postboks 135
N-1601 Fredrikstad
NORWAY

Jøtul USA, Inc.
400 Riverside Street
Portland, Maine 04104