

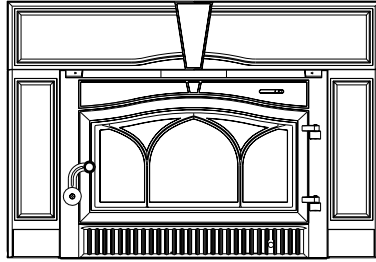

Jøtul C 350 Winterport
Fireplace Insert



Jøtul C 350 Winterport Fireplace Insert

Installation and Operating Instructions
for the United States & Canada



Keep these instructions for future reference.

Table of Contents

Standards and Safety Notices

Standards / Codes 3
 Safety Notices 4
 Preparation 4
 Unpacking the Firebox 4

Specifications

Jøtul C 350 Winterport Fireplace Insert..... 5
 Dimensions 5

Installation

Masonry Fireplace Requirements 6
 Factory-built Fireplace Requirements 6
 Chimney Height..... 6
 Hearth Protection 7
 Clearance to Combustibles 8
 Chimney Connection 10
 Firebox Installation 10
 Surround Assembly 12

Operation

Combustion Efficiency 13
 CO Emissions 13
 Wood Fuel and Performance 13
 Functionality 13
 Air Control Settings..... 14
 Break-in Procedure 14
 Starting / Maintaining the Fire..... 15
 Adding Fuel 15
 Formation of Creosote 15
 Blower Operation 16

Maintenance

Ash Removal 17
 Glass Care 17
 Chimney System 18
 Gaskets..... 19
 Blower 19

Illustrated Parts Breakdown

Exploded View 20
 Parts Listing 21

Appendix A

Door Knob Assembly 24
 Baffle Plate Removal 24

Warranty Statement 25

For Your Records...

Record the following information to help your dealer determine what you will need should your fireplace ever require parts or service. The serial number and manufacturing date are indicated on the permanent label located in the blower compartment under the firebox. You may also wish to attach your sales receipt to this manual for future reference.

Model: Jøtul C 350 Winterport Fireplace Insert

Serial Number:

Purchase Date:

Dealer:

Phone:

Installed by:

Date:

PLEASE NOTE:

IT IS NORMAL FOR SMOKE AND ODOR TO OCCUR DURING THE INITIAL STAGES OF OPERATION, DEPENDING UPON TEMPERATURES GENERATED OVER TIME. THIS "CURING" CONDITION CAN BE ALLEVIATED BY PROMOTING FRESH AIR CIRCULATION WITHIN THE IMMEDIATE VICINITY OF THE APPLIANCE.

NATIONAL
FIREPLACE
INSTITUTE



CERTIFIED
www.nficertified.org

We recommend that our gas hearth products be installed and serviced by professionals who are certified in the U.S. by the National Fireplace Institute® (NFI) as NFI Gas Specialists.

Standards

The Jøtul C 350 Winterport fireplace insert has been tested and listed to the following standards:

U.S: ANSI/UL 1482-2011

Canada: CAN/ULC-S627-00

Certified Safety Tests performed by:

ITS, Intertek Testing Services

Middleton, Wisconsin

Manufactured by:

Jøtul North America

55 Hutcherson Drive

Gorham, Maine 04038-2644

The Jøtul C 350 Winterport fireplace insert is listed to burn solid wood only. Do not burn any other fuels.

This manual describes the installation and operation of the Jøtul C 350 Winterport fireplace insert. Read this entire manual before you install and use this appliance. Save these instructions for future reference and make them available to anyone using or servicing the fireplace insert.

This wood heater requires periodic inspection and repair for proper operation. See this manual for specific maintenance information. It is against federal regulations to operate this wood heater in a manner inconsistent with the operating instructions in this owner's manual.

Combustion Specifications

Heat Output*: Under specific test conditions, this heater has been shown to deliver heat ranging from 11,420 to 34,200 BTU's.

Efficiency*: 63%

CO Emissions: N/A

Pariculate Emissions: 4.0 g/hr

* Default values per previous Federal Register 40 CFR Part 60, Subpart AAA.

EPA validated efficiency and CO values were unavailable at the time of this printing. These values will be made available in the manual and on the Jotul website (www.jotul.us) for your reference in the near future.

WARNING !

THIS WOOD HEATER HAS A MANUFACTURER-SET MINIMUM LOW BURN RATE THAT MUST NOT BE ALTERED. IT IS AGAINST FEDERAL REGULATIONS TO ALTER THIS SETTING OR OTHERWISE OPERATE THIS WOOD HEATER IN A MANNER INCONSISTENT WITH OPERATING INSTRUCTIONS IN THIS MANUAL.

This heater meets the 2015 U.S. Environmental Protection Agency's emission limits for wood heaters manufactured after May 15, 2015.

Check Building Codes

When installing, operating and maintaining your Jøtul C 350 Winterport fireplace insert, follow the guidelines presented in these instructions, and make them available to anyone using or servicing the stove.

In the U.S., the National Fire Protection Association's Code, NFPA 211, *Standards for Chimneys, Fireplaces, Vents and Solid Fuel Burning Appliances*, or similar regulations, may apply to the installation of a solid fuel burning appliance in your area.

In Canada, the guideline is established by the CSA Standard, CAN/CSA-B365-M93, *Installation Code for Solid-Fuel-Burning Appliances and Equipment*.

Always consult your local building inspector or authority having jurisdiction to determine what regulations apply in your area.

THE JOTUL C 350 FIREPLACE INSERT IS NOT APPROVED FOR USE IN MOBILE HOMES.

NOTICE:

YOU SHOULD CONSULT THE AUTHORITY HAVING JURISDICTION IN YOUR LOCALE (SUCH AS MUNICIPAL BUILDING DEPARTMENT, FIRE DEPARTMENT, FIRE PREVENTION BUREAU, ETC.) BEFORE INSTALLATION TO DETERMINE THE NEED TO OBTAIN A PERMIT.

Safety Notices

- **BURN SOLID WOOD FUEL ONLY. DO NOT BURN OTHER FUELS.**
- **DO NOT USE CHEMICALS OR FLUIDS TO START THE FIRE. DO NOT BURN GARBAGE OR FLAMMABLE FLUIDS.**
- **IF THIS ROOM HEATER IS NOT PROPERLY INSTALLED, A HOUSE FIRE MAY RESULT. TO REDUCE THE RISK OF FIRE, FOLLOW THE INSTALLATION INSTRUCTIONS. FAILURE TO FOLLOW THESE INSTRUCTIONS MAY RESULT IN PROPERTY DAMAGE, BODILY INJURY, OR LOSS OF LIFE.**
- **CONTACT THE LOCAL BUILDING OR FIRE OFFICIALS ABOUT RESTRICTIONS AND INSTALLATION INSPECTION REQUIREMENTS IN YOUR AREA. WHEN NOT ADDRESSED IN THIS MANUAL, OR BY LOCAL CODE AUTHORITIES, INSTALLATION SPECIFICATIONS AND REQUIREMENTS DEFER TO NFPA 211 OR CSA B 365.**
- **DO NOT CONNECT THIS FIREPLACE TO ANY AIR DISTRIBUTION DUCT OR SYSTEM.**
- **DO NOT USE GRATES OR ANDIRONS TO ELEVATE THE FIRE. BUILD FIRE DIRECTLY ON THE FIRECHAMBER FLOOR.**
- **EXTREMELY HOT WHILE IN OPERATION! KEEP CHILDREN, CLOTHING AND FURNITURE AWAY. CONTACT WILL CAUSE SKIN BURNS.**
- **NEVER OPERATE THE FIREPLACE WITH A CRACKED OR BROKEN GLASS PANEL.**
- **Install smoke detectors in the living areas and bedrooms of your home. Test them regularly and install new batteries twice annually. When installed in the same room as the stove, a smoke detector should be located as far from the stove as possible to prevent it from sounding when adding fuel to the fire.**
- **Avoid creating a low pressure condition in the room where the stove is operating. Be aware that operation of an exhaust fan or clothes dryer can create a low pressure area and consequently promote flow reversal through the stove and chimney system. The chimney and building, however, always work together as a system - provision of outside air, directly or indirectly to an atmospherically vented appliance will not guarantee proper chimney performance. Consult your local Jøtul authorized dealer regarding specific installation/performance issues.**

Preparation

We strongly urge you to have your authorized Jøtul dealer install your new Jøtul C 350 Fireplace Insert.

- Check with local building officials to determine what permits may be required before installation.
- Notify your insurance company before installing this fireplace.

Unpacking the Fireplace

All firebox components of the Jøtul C 350 Fireplace Insert are contained within the carton on a single pallet. As you unpack the contents, inspect each item for damage. Notify your dealer of any damage such as dents, cracked glass, or broken bricks.

Contents:

- Firebox Assembly - including Firebricks
- Steel Riser Bar
- Surround Panels (Breakdown on page 13)
- Stove Hardware Bag
 - Fireplace Conversion Notice Plate
 - Blower Power Cord
 - AC Power Receptacle Lead
 - Receptacle Inlet Coverplate
 - Door Knob parts
 - Blower Control Knob
 - Firebox Locking Pin

Tools & Materials Required:

- work gloves
- safety glasses
- tape measure
- phillips screwdriver
- tin snips
- power drill
- High-temperature sealant
- 1" (25 mm) masonry anchors or nails (two)
- 1/4" x 3/4" self-tapping screws (three)
- 10 mm (1/4") open end wrench or socket driver

Removing the Firebox from Pallet

1. Remove the two screws that secure the steel Riser Bar assembly to the back of the pallet. See page 8 to determine if Riser Bar is required for your installation.
2. The firebox may be lightened by removing the door, firebricks and baffle plates. See fig. 22, page 22.
3. The firebox is secured to the pallet by a steel bracket on each side and one screw in the bottom at the front. Use a 1/4 socket to remove these five screws and lift the firebox to disengage the brackets. Discard brackets.
4. Install the Blower Control Knob.
5. Install the Door Knob parts in the order shown in fig. 21, page 22.

Jøtul C 350 Winterport Specifications

Performance

Fuel: 20" Logs
 Heat Output¹: 40,000 BTU/hr. (4.1 kg/hr.)
 Heating Capacity²: Up to 1,300 sq. ft.
 Overall Efficiency³: 71%
 Emissions: 4.0 grams/hr.
 Burn Time: Up to 7 hours
 Dual Blowers: 110 cfm.
 Shipping Weight: 425 lbs. (193 kg.)

- ¹ Maximum Heat Output based on total kilograms of dry wood burned in a one hour period. Under specific EPA test conditions, this heater has generated heat output rates ranging up to 40,000 BTU's per hour. Heat output in residential installations may vary depending upon site-specific conditions.
- ² Heating Capacity and Maximum Burn Time will vary depending on design of home, climate, wood type and operation.
- ³ Overall Efficiency is based on a burn rate of .99 kg wood per hour.

Optional Surrounds and Accessories

Steel Wide Surround, 40" x 30" / Matte Black	156055
Trimable Surround, 37" x 25 1/2" / for Z-C fireplaces	157326
Draw-Down Adaptor Kit	156073
Stove Gloves	157363
Universal Gasket Kit	157050

The Jøtul C 350 Winterport Fireplace Insert meets U.S. EPA emission limits for wood heaters sold after July 1990, and is tested and listed to ANSI/UL 1482, and CAN/ULC S628.93. It is intended for installation in accordance with NFPA 211 or CAN/CSA B365.

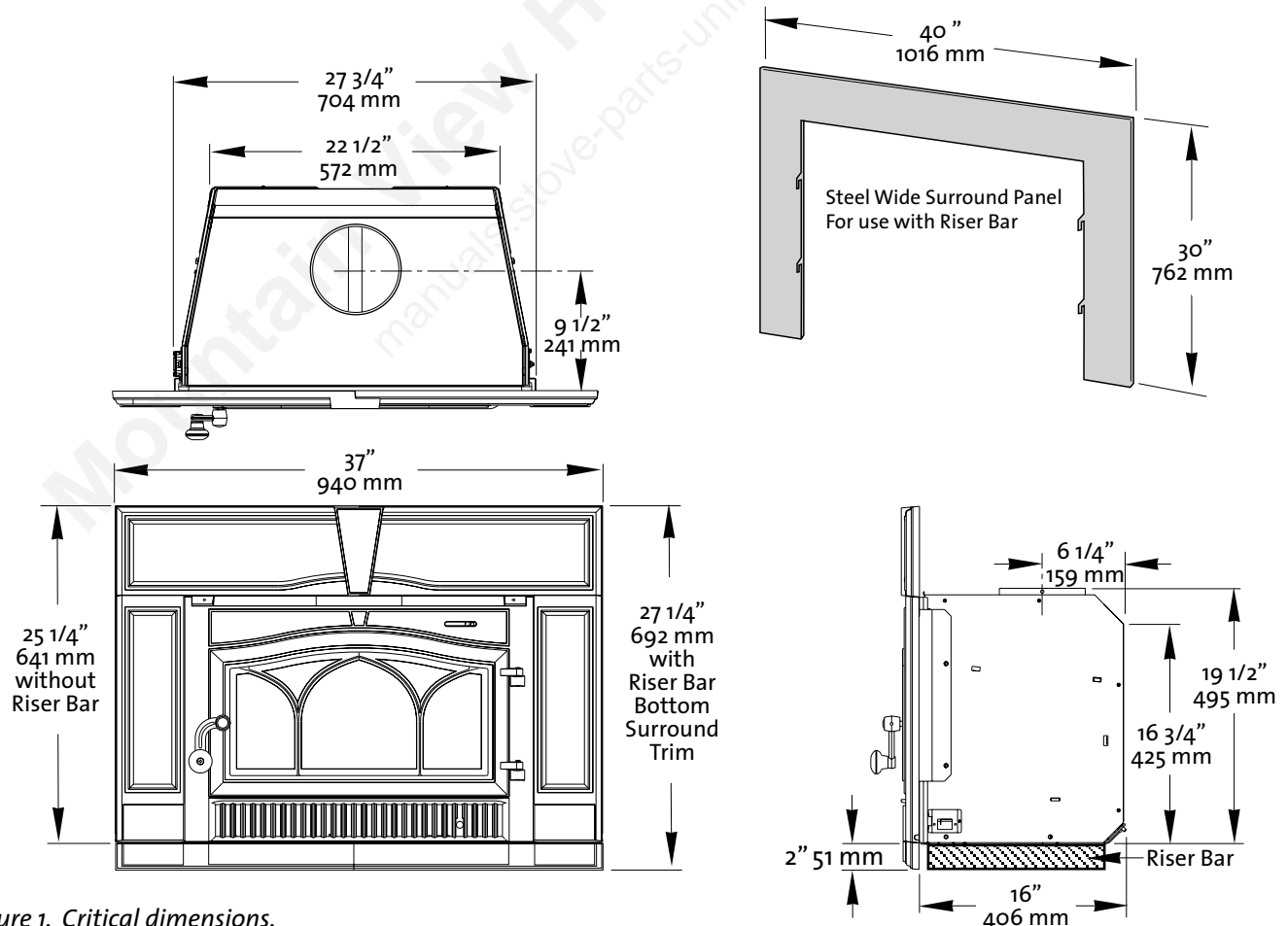

Figure 1. Critical dimensions.

Installation

Masonry Fireplace Requirements

- The entire fireplace and chimney must be cleaned and inspected before installation. The system must meet local building code requirements.
- The structure and components must be free of any defects such as cracks or broken bricks or flue tiles. Any damage must be repaired before installation.
Any opening that may exist between the masonry of the fireplace and the facing masonry must be permanently sealed.
- The chimney must have a clay tile liner or a stainless steel liner utilizing a positive connection.
- **Do not remove bricks or mortar from the fireplace or chimney.** However, masonry or steel may be removed from the smoke shelf and adjacent damper frame area to accommodate installation of a chimney liner, provided that their removal will not weaken the structure of the fireplace or chimney, and will not reduce protection for combustible materials.
- **Chimney Height:**
Minimum - 15 ft. (4.57 meters)
Maximum - 33 ft. (10.5 meters)

Minimum Fireplace Dimensions

- A: Front Width * 32" (813 mm)
- B: Height** 19 1/2" (495 mm)
- C: Rear Width 22 3/4" (577 mm)
- D: Rear Height** 16 3/4" (425 mm)
- E: Depth 16" (406 mm)

*NOTE: Width dimension accommodates clearance for Surround attachment and blower power cord routing.
** Add 2" (51 mm) for use with optional Riser Bar.

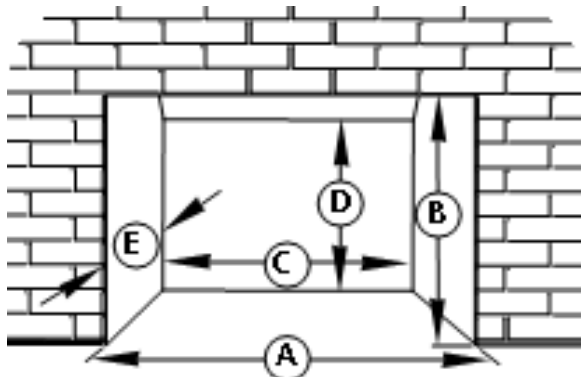

Figure 2. Minimum fireplace dimensions.

Factory-Built Fireplace Requirements

The Jøtul C 350 Winterport may be installed into a factory-built fireplace with the following conditions:

- The factory-built fireplace must be listed per UL 127 or ULC S610.
- Installation must include a full height, listed chimney liner meeting type HT requirements (2100F) per UL 1777 (U.S.) or ULC S635 (CAN). The liner must be securely attached to the insert flue collar and the chimney top.
Some liner manufacturers require insulation in order to achieve a UL 1777 or ULC-S635 listing. Check with the manufacturer of the liner being used to determine if insulation is required. Insulation is recommended particularly if the chimney flue is located in a chase outside of the building envelope.
- The top plate of the liner system **MUST NOT** block the air flow between the cooling walls of the zero-clearance fireplace air-cooled chimney system. These cooling walls **MUST** remain open under all conditions to maintain proper circulation of cooling air.
- The damper or fireplace opening must be sealed to prevent passage of room air into the chimney cavity.
- The convection chamber and/or air circulation louvers of the zero-clearance fireplace **MUST NOT** be blocked-off. This requirement may preclude use of the cast iron surround panels. A custom-built surround panel system may be used provided it does not interfere with air circulation through the convection chamber.

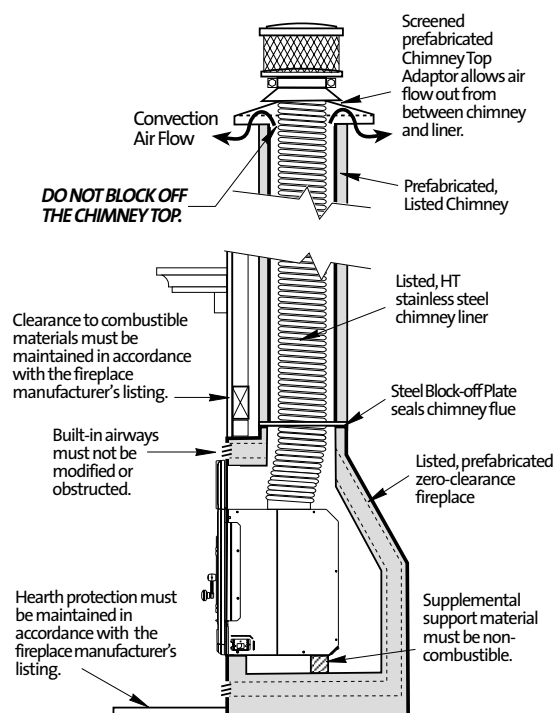

Figure 3. Zero-clearance fireplace installation.

Zero-clearance fireplace installation, cont'd.

- Alteration of the zero-clearance fireplace functionality or structure is not permitted; i.e. firebrick or refractory panels **MUST NOT** be removed to accommodate the fireplace insert installation. Alteration of the zero-clearance fireplace is limited to:
 - a) removal of the damper for liner installation
 - b) removal of external, nonfunctional trim which then must be stored within the fireplace for potential future re-assembly.
- Fireplace Conversion Notice PN 220508 must be permanently attached to the back of the fireplace. This metal label is included in the bag containing this manual.
- Means must be provided to properly support the front of the insert if it projects from the fireplace front. The weight of the insert must not compromise the structural integrity of the zero-clearance fireplace.
- Means must be provided to remove the insert or baffle to facilitate cleaning the chimney flue.
- Final approval is contingent on the authority having local jurisdiction.

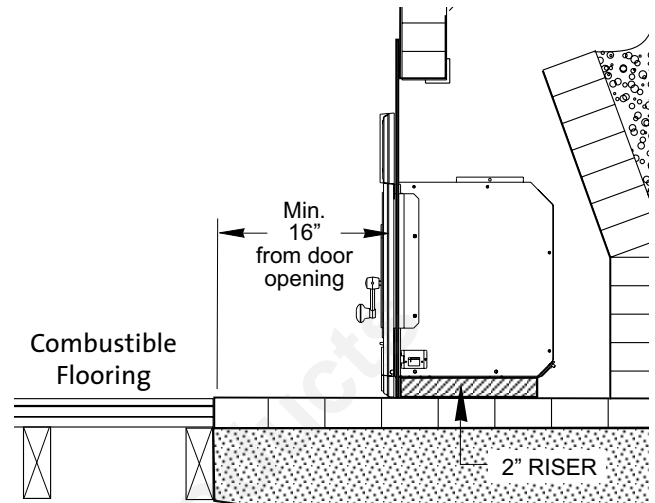

Figure 4. Required hearth protection if flush with combustible floor materials. Riser Bar must be installed.

Hearth Protection Requirements

The floor area in front of fireplace insert must be protected from live sparks and radiant heat.

- **Materials:** Hearth protection must be non combustible insulating board, or the equivalent mortared masonry material. Alternate protection must composed of materials as specified by NFPA 211.
- **Protected Area:** 16" Deep x 34 1/2" Wide, for both the U.S. and Canada.
 - A) Front** - The protection must extend at least 16 inches (406 mm) forward from the fireplace insert door opening.
 - B) Sides** - Protection must extend 17 1/4 inches (438 mm) to both sides of the centerline of the insert. See fig 5.
- **Flush Hearth:** Where the hearth construction is flush with combustible floor materials, the insert must be elevated with use of the 2" Riser Bar supplied. See fig. 4.
- **Raised Hearth:** Where the hearth construction is a minimum of 2 1/2" thick, the insert may be installed without use of the Riser Bar. See fig. 4a.

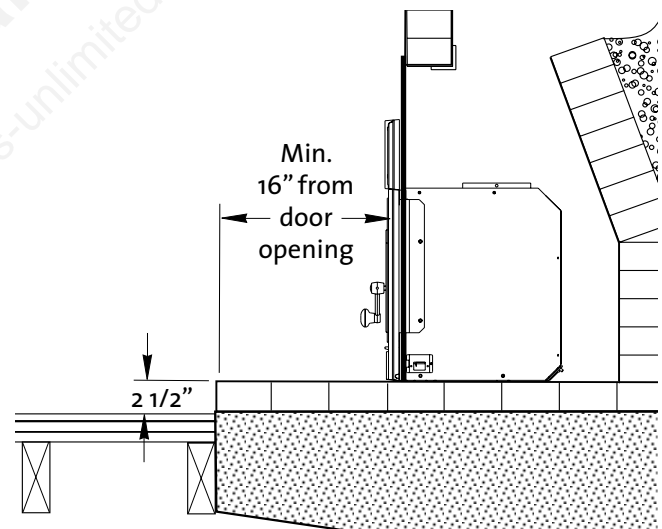

Figure 4a. Minimum raised hearth requirement. Riser Bar not required.

Chimney Connection

This insert must be connected to a code-approved masonry chimney or listed factory-built fireplace chimney with a direct (positive) flue connector into the first chimney liner section. The chimney size should not be less than, nor more than, three times greater than the cross-sectional area of the flue collar.

The optional Jøtul Draw-Down Adaptor Kit 156073 is available to ease connection of the chimney liner with the flue collar.

A positive connection must be made between the fireplace insert and the chimney by one of the following approved methods.

U.S. Requirement:

The insert is connected to a listed stainless steel flexible connector that extends into the first chimney flue tile liner. A sealed block-off plate must be installed at the damper area of the existing fireplace. See fig. 7.

For internal chimneys, (no sides of the chimney exposed to the outside below the roofline,) a positive connection to the first flue tile is acceptable provided the tile is no larger than 8" x 12".

For external chimneys (one or more sides are exposed to the outside below the roof line, including garages), a positive connection to the first flue tile is acceptable provided the tile is no larger than 8" x 8".

A 6", 7", or 8" stainless steel liner, extending the full height of the chimney, is required for all installations where the flue tile is greater than 8" x 12" for internal chimneys, or 9" x 8" for external chimneys.

Canada Requirement:

The insert must be installed with a continuous chimney liner of 6" (152 mm) diameter extending from the fireplace insert to the top of the chimney. The chimney liner must conform to the Class 3 requirements of CAN/ULC-S635, Standard for Lining Systems for Existing Masonry or Factory-Built Chimneys and Vents, or CAN/ULC-S640, Standard for Lining Systems for New Masonry Chimneys. See fig. 8.

Do not use aluminum or galvanized steel pipe for chimney connection components - these materials are not suitable for use with solid fuel.

Installation

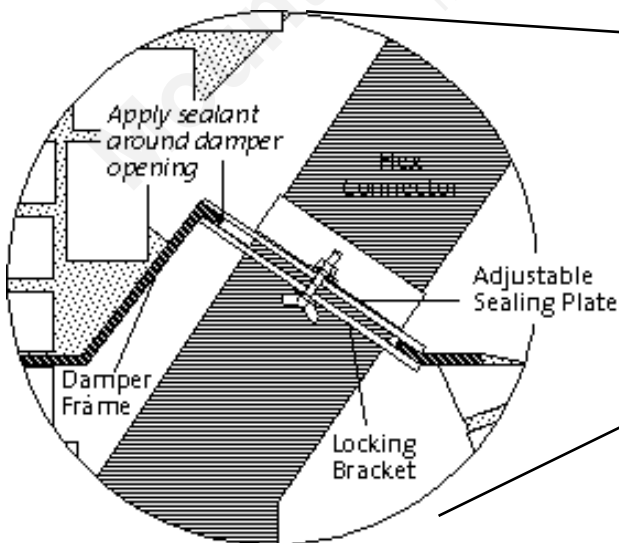
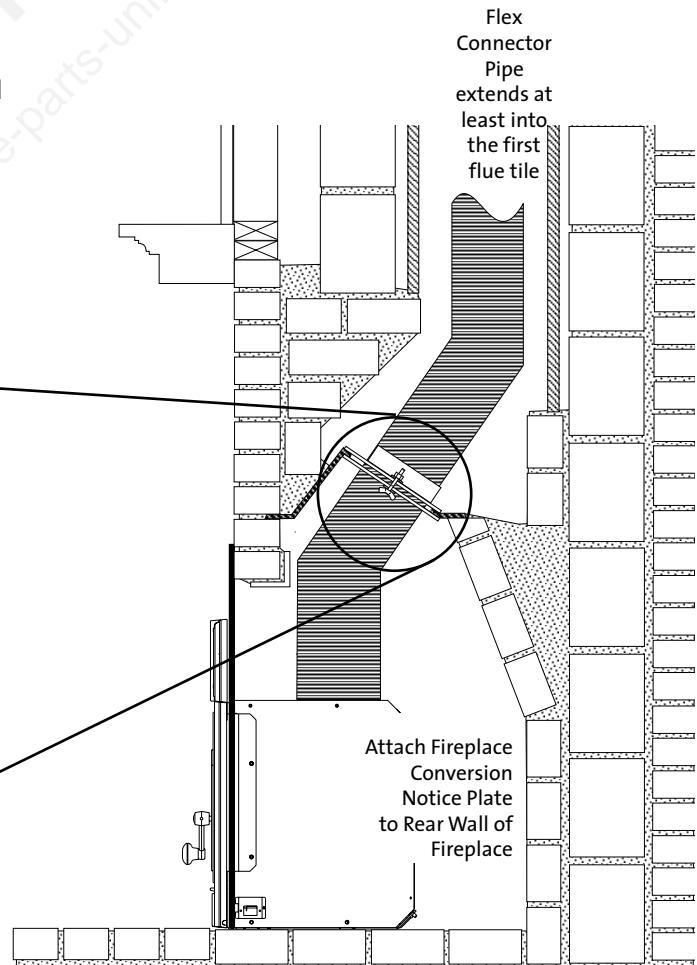

Figure 7. Positive Chimney Connection - U.S.



1. Remove the existing damper and linkage components from the fireplace. Alternatively, you can wire the damper plate to lock it in the open position. Thoroughly clean the firebox and smokeshef area with a wire brush.
2. If the fireplace has been modified to accommodate installation, use anchors or masonry nails to attach the metal Fireplace Conversion Notice Plate (PN 220508) to the back wall of the masonry fireplace firebox where it will be readily seen should the insert be removed.
3. Install the Flex Connection plate according to the manufacturer's instructions. The sealing plate may require trimming to accommodate your specific fireplace damper.

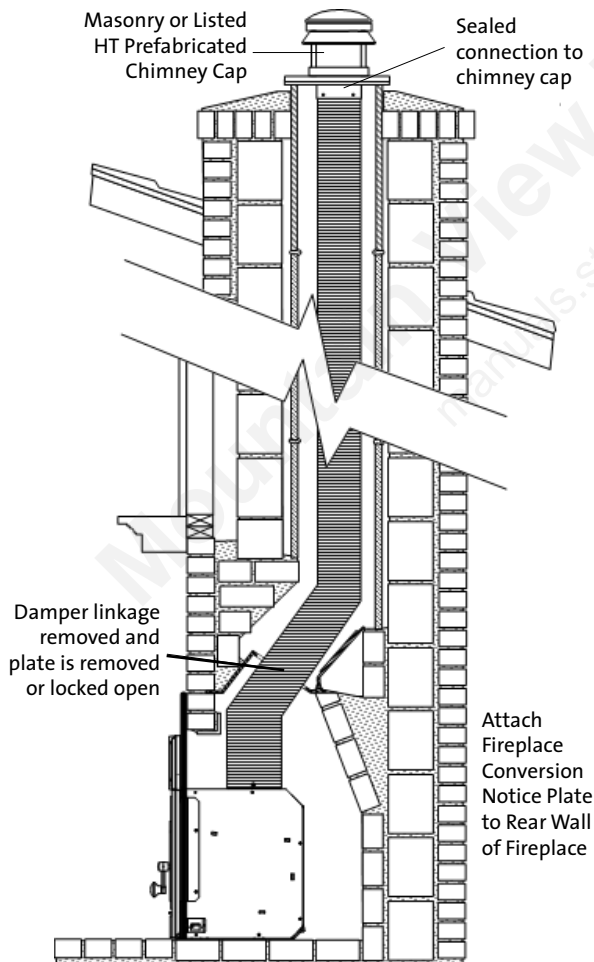

Figure 8. Positive Chimney Connection - Canada.

Installing the Fireplace Insert

Leveling Bolts

The leveling bolts are used to compensate for irregular hearth surfaces. More importantly, they also provide a method of adjustment for the correct vertical (plumb) and horizontal (level) alignment of the surround assembly with the fireplace face and hearth.

If you are installing the Bottom Trim section with the Surround assembly, you must use the leveling bolts to level the front-to-back pitch of the firebox or the Surround assembly will be out of plumb. See fig. 9 below.

Install the leveling bolts all the way into either the Riser Bar or Firebox.

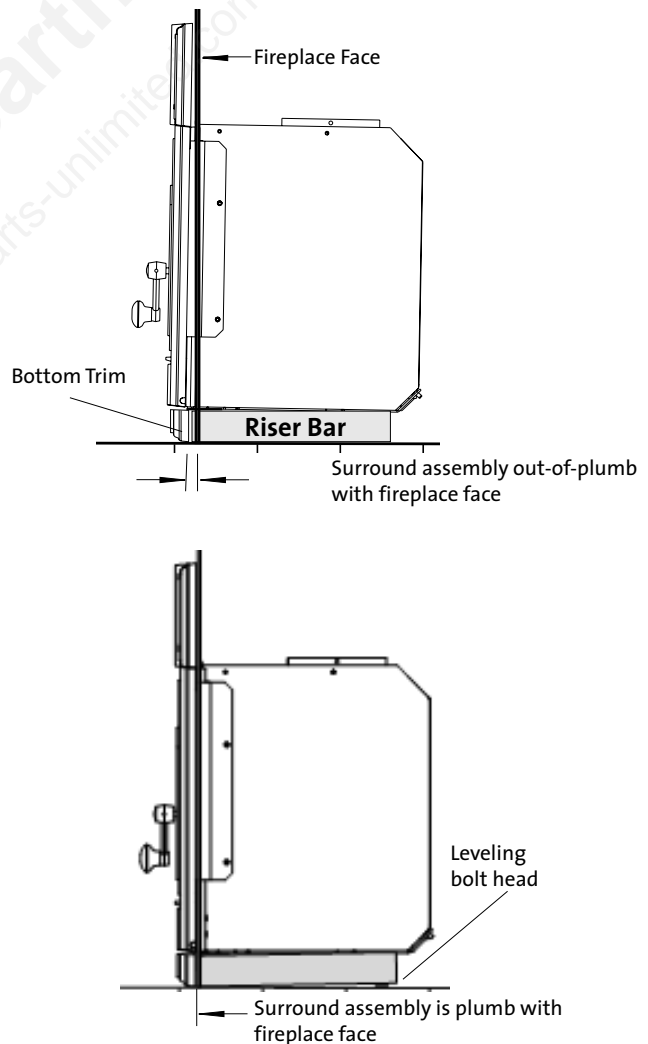

Figure 9. Using the leveling bolts to adjust surround assembly alignment.

Install the Riser Bar

1. If appropriate to your installation (see pg. 8), position the riser bar centered within the fireplace as shown in fig. 10. The forward ends of the Riser Bar should be aligned within 1/2 inch of the fireplace face.

Install the Firebox

1. With the help of an assistant, slide the Firebox into the fireplace cavity. If using a Riser Bar, the Firebox must be engaged with the Riser by means of the Locking Pin included in the hardware bag. Pull the Left Blower forward out of the way to access the Locking Pin hole in the firebox floor. See figs. 10 and 11. When the front edge to the firebox is aligned with the front edge of the Riser, the Locking Pin hole will be aligned with the slot in the top of the Riser Bar crossmember. Insert the Locking Pin and pull the firebox out slightly proud of the fireplace face to facilitate attaching the surround panels. Relocate the blower.

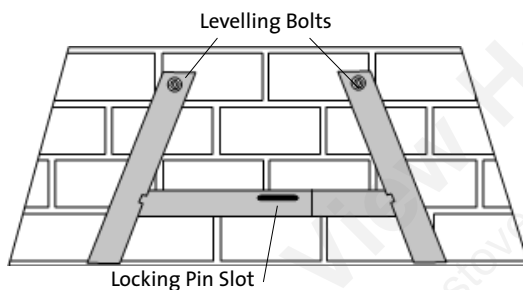

Figure 10. Riser Bar placement.

2. Secure the flue connector to the firebox flue collar using three 1/4" x 3/4" self-tapping screws.
3. Determine to which side the blower power cord will be routed. Insert the AC power receptacle lead through the appropriate inlet in the side of the firebox. See fig. 12. Remove the #8 x 5/8" phillips screw already in place and engage the receptacle bracket with the tab in the inlet opening. Reinstall the screw.
4. Plug the male quick-connector on the end of the lead into the corresponding female connector on the blower wire harness.
5. Plug the power cord into the receptacle.
6. Install the inlet coverplate over the inlet opening on the other side of the firebox using the pre-installed #8 x 5/8" screw. Fig. 13.

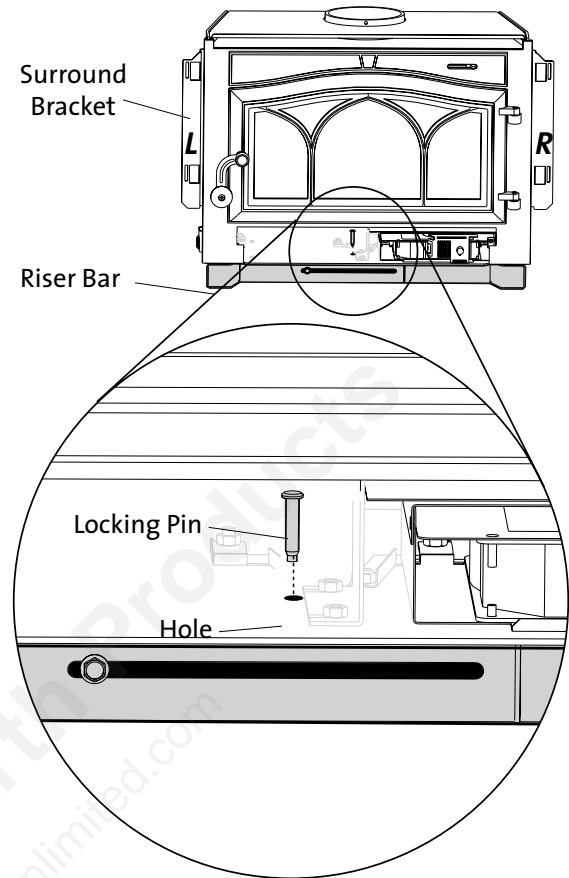

Figure 11. Insert Riser Bar Locking Pin.

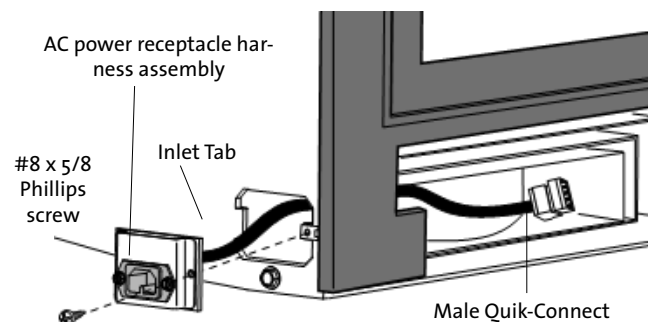

Figure 12. AC power receptacle lead routing.

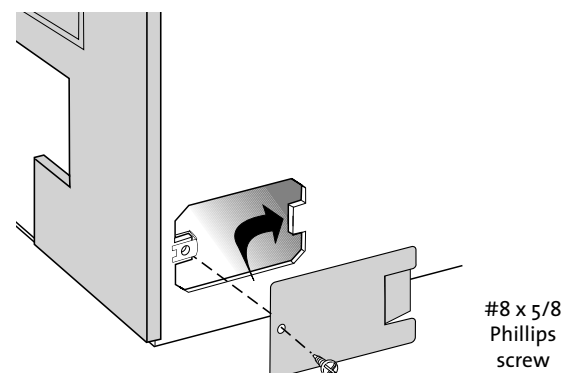

Figure 13. Receptacle Inlet Coverplate installation.

Figure 12.

Surround Panel assembly viewed from backside.

Tools Required:

- 10 mm socket or wrench

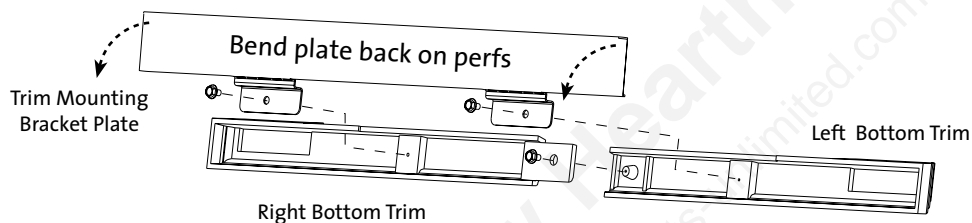
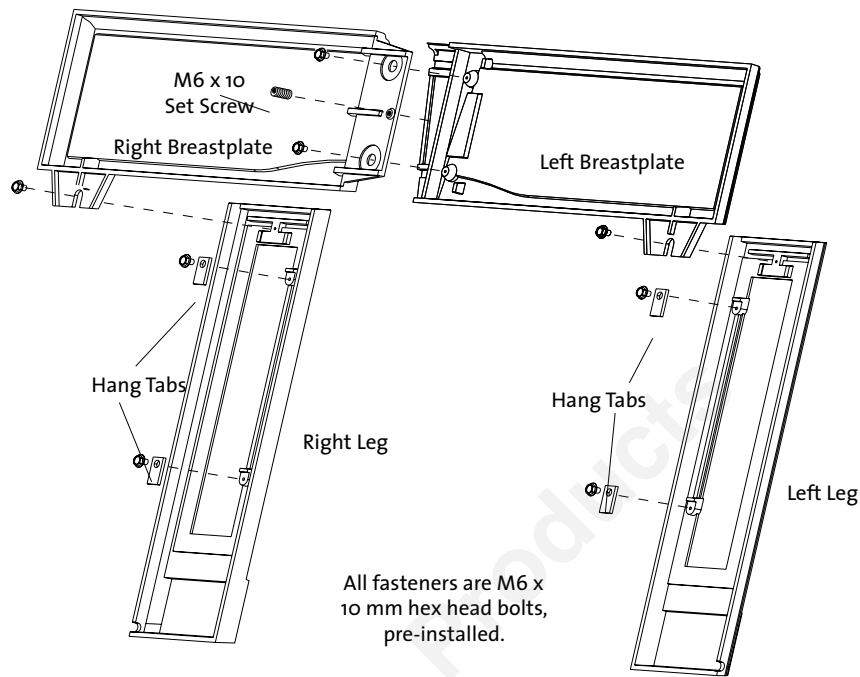

Figure 14. Bottom Surround Trim assembly.

Surround Assembly

All fasteners have already been installed in the appropriate locations at the factory. You will need to remove them, attach the parts together as described below and reinstall the fasteners at those locations.

- 1. Layout the parts.** Place the castings face down on a protective surface such as carpeting, blankets or a sheet of cardboard.
- 2. Attach the Breastplates to each other.** Use a 10 mm socket or wrench with two M6 x 10 hex head flange bolts. Adjust the set screw to obtain parallel alignment of the two plates.
- 3. Attach the Leg plates.** The Legs must be oriented with the Hang Tabs on the inside edges as shown in fig. 12. Use the two remaining M6 x 12 hex head flange bolts to attach the Legs to the Breastplate assembly.
- 4. If the Riser Bar is used,** attach the two Bottom Surround Trim panels together with the single M6 x 10 hex bolt. Attach the Trim Mounting Bracket to the back of the Bottom Trim assembly using the other two M6 x 10 bolts. **Be sure to orient the bracket as shown in fig. 14.**

Tighten just snug enough to allow for final adjustment when the Surround assembly is attached to the firebox.

Bend the perforated mounting plate down 90° as shown in Fig 14. Insert and center the bracket plate sandwiched between the firebox and the Riser Bar.

- 5. If appropriate, attach the Extended Surround Panel** to the firebox. With the painted side facing out, engage the hooked tabs on panel with the slots in the backside of the Surround Brackets on the firebox. Extend the blower power cord out beyond the surround panel.
- 6. Attach the Assembly to the Firebox.** Lift the entire assembly upright and position it in front of the insert firebox. The four Hang Tabs on the surround legs must engage with the adjacent cutouts in the two brackets on either side of the firebox opening. The surround will easily engage with these brackets if the firebox is slightly proud of the fireplace opening.

Hang the surround assembly on the firebox and push the entire unit into position so that the surround is flush against the fireplace face.

Operation

Read the following section carefully before building a fire in your fireplace insert.

Combustion Efficiency

EPA qualified tested efficiency values are not currently available for the Jøtul C 350. The EPA default efficiency for non-catalytic wood heaters is 63% per Federal Register 40 CFR Part 60, Subpart AAA. There are, however, aspects of efficiency that you should be aware of in order to get the most from your stove.

Operation habits and fuel moisture can have a significant effect on efficiency. Poorly seasoned wood having a higher than optimum moisture content, can reduce the amount of energy transferred to the living area as a result of the energy expended to evaporate the excess fuel moisture in order for the wood to burn. Operational aspects, such as not building a robust kindling fire to readily ignite the larger fuel pieces, can result in an inefficient smoldering fire. Additionally, most modern wood heaters' optimum performance and efficiency are at the medium to medium-low burn rates.

The location of the stove can have a significant effect on heating efficiency, primarily in regards to distribution of the heat. For example, a wood heater centrally located in the residence in an open living area will likely provide better circulation of heat than will a stove located in a room adjacent to the larger living area.

CO Emissions

EPA qualified tested carbon monoxide (CO) values are not currently available for the Jøtul C 350. There are, however, aspects of CO that you should know. Most all means of combustion produce CO, including wood fires. Maintaining a well-established fire and avoiding operation that produces a smoldering, smoky fire, will greatly reduce CO levels.

It is highly recommended that a CO monitor (detector) be installed in the same room as the stove. The monitor, however, should be located as far away as possible from the stove to avoid alert soundings when adding fuel to the fire.

Wood Fuel and Performance

The Jøtul C 350 is designed to burn natural wood only. Higher efficiencies and lower emissions generally result when burning air-dried, seasoned hardwoods, as opposed to softwoods, green or freshly cut hardwoods. Wood that has been air-dried for a period of 6 to 14 months will provide the cleanest, most efficient heat. Wood seasoned more than 2 years will burn too quickly to take advantage of the stove's low end efficiency strength.

A seasoned log will have check marks on the ends and be lighter than an unseasoned log which will show little or no check marks.

We recommend using a moisture meter to determine the moisture content of your wood. For purposes of home heating, your fuel should have a moisture content between 12 - 20%. Wood with higher moisture content will burn, however, very inefficiently. Most of its heat value will be lost to driving water out of the wood. Worse, that moisture will condense as creosote in the relatively cool chimney flue, increasing the potential for a chimney fire. Use of unseasoned wood defeats the purpose of any modern wood-burning appliance.

DO NOT BURN:

- Coal;
- Garbage;
- Synthetic fuel or logs;
- Material containing rubber, including tires;
- Material containing plastics;
- Waste petroleum products, asphalt products, paints, paint thinners or solvents;
- Materials containing asbestos;
- Construction or demolition debris;
- Railroad ties or pressure-treated wood;
- Manure or animal remains;
- Salt water driftwood or other previously salt-water saturated materials;
- Unseasoned wood; or
- Paper products, cardboard, plywood, or particle board. (The prohibition against burning these materials does not prohibit the use of fire starters made from paper, cardboard, saw dust, wax or similar substances for the purpose of starting a fire.)

The burning of any of these materials can result in the release of toxic fumes, or render the heater ineffective and cause smoke. Never use gasoline, gasoline-type lantern fuel, kerosene, charcoal lighter fluid, or similar liquids to start or "freshen-up" the fire. Always keep such liquids away from the heater at all times.

C 350 Functionality

When used with dry wood and a well-drafting chimney system, modern non-catalytic wood stoves burn fuel efficiently by the precise control and delivery of primary and secondary air to the fire.

Primary Air is drawn into an inlet at the rear of the firebox and directed through a regulator shutter under the front door before entering the lower fire chamber. Additional primary air is directed to the top of the front door to act as an air wash which may prevent extreme soot build-up on the glass panel. The amount of primary air available to the fire determines the intensity of heat output and rate of fuel combustion; the greater the amount of air, the greater the heat output, the faster the wood burns.

The primary air setting also determines the effectiveness of the air wash over the glass; the higher the setting, the cleaner the glass will remain. Additional air is separately directed into the top of the fire chamber to support combustion of exhaust gasses before passing out of the stove. This unregulated **Secondary Air** enters through the inlet in the rear of the firebox and is heated as it passes over the back into a two-tiered manifold at the top of the firechamber. Volatile gases, released unburned from the fuel bed, rise to the baffle where they are turbulently mixed with the hot, fresh oxygen. Secondary combustion then occurs before the gases pass into the heat exchange chamber.

Air Control Settings

A single lever regulates the Primary Air flow that controls the intensity of the fire and consequent heat output and burn time. This lever is located within the slot on the upper right front of the fireplace insert.

When first starting or reviving the fire, the control lever should be set at the far right position to allow the maximum amount of air into the stove. See fig.15. After the fire is well-established, the lever should be set at position to moderate incoming air to maintain the desired long term heat output and/or burn time.

In general, the more air made available to the fuel will result in the hottest fire intensity and the fastest fuel consumption. Alternatively, the less air made available to the firebox will result in low heat output and slow fuel consumption.

Break-in Period

The cast iron parts of your fireplace insert require a break-in process to allow them to gradually adjust to thermal expansion and contraction. This is accomplished by building a series of three or four fires, each somewhat hotter than the last. Allow the fireplace insert to cool completely before building the next fire.

Limit the first fire to just kindling and a couple of 1-2 inch logs and add progressively more and larger logs to subsequent fires, keeping the Air Control set to the fully open position.

It is normal for a new fireplace insert to emit odor and possibly smoke during the first few fires. This is characteristic of the burn-off of residues from the manufacturing process and the curing of painted surfaces. Open a window near the fireplace insert to provide plenty of fresh air to the room during this temporary "seasoning" period.

**ALWAYS WEAR STOVE GLOVES WHILE TENDING THE FIRE.
NEVER ALLOW THE FIRE TO REST DIRECTLY ON THE GLASS.
KEEP THE LOGS SPACED AT LEAST ONE INCH FROM THE GLASS TO ALLOW FOR PROPER AIR FLOW WITHIN THE STOVE.
AVOID STRIKING THE GLASS.**

Blower Settings / Air Control

Use the following guide for best performance.

Burn Rate	Air Control Setting	Blower Speed
Low	1/8" Open	Low / On at 30 min.
Med. Low	3/16" Open	Low / On at 30 min.
Med. High	1/4" Open	Low / On at 30 min.
High	Max. Open	High / On

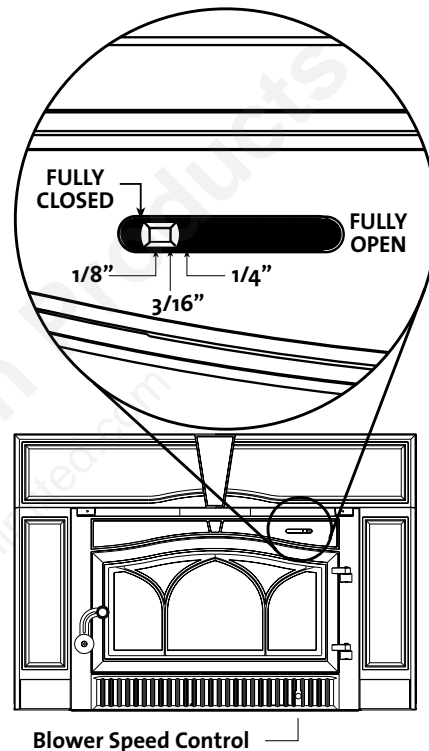

Figure 15. C 350 Air Control Setting

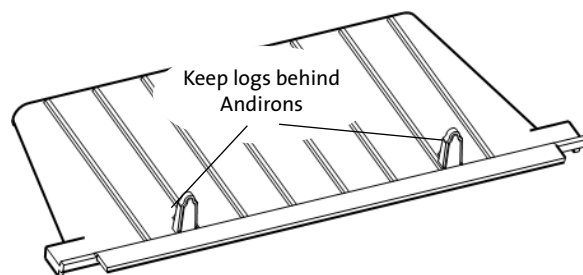

Figure 16. Fuel load area - keep logs behind the andirons.

DO NOT OVERFIRE THE STOVE. IF ANY PART OF THE STOVE OR CHIMNEY GLOWS, YOU ARE OVERFIRING. A HOUSE FIRE OR SERIOUS DAMAGE TO THE STOVE OR CHIMNEY COULD RESULT. IF THIS CONDITION OCCURS, IMMEDIATELY CLOSE THE AIR CONTROL.

Starting and Maintaining a Fire

Burn only solid wood directly on the bottom grate of the stove. Do not elevate the fire in any way.

Traditional Fire Building

1. With the primary air control lever in the full open position (*to the right*), start with several sheets of crumpled newspaper placed directly on the grate. On top of the newspaper, place several pieces of small dry kindling (approx. 1" in diameter) with two to three larger logs (approx. 3" to 5" in diameter) on top.
2. Light the fire and close the door, gradually building the fire by adding larger and larger logs. Be sure to follow the break-in procedure before creating a hot fire that might damage the stove.
3. Once the fire has become well established, adjust the primary air control lever as necessary to generate the desired heat output and burn time.

Top-Down Fire Building - See fig. 17.

Many people find this method to be superior to the traditional method.

1. With the primary air control lever in the full open position (*to the right*), place two short 1/4-split logs on the firebox floor, perpendicular to the rear wall, about 6 inches apart.
2. Place kindling across the base logs.
3. Place one or two smaller logs on top of the kindling.
4. Place newspaper between the two bottom logs under the kindling. Light the news paper and close the door. Continue to add kindling and small logs as necessary to build the fire. Keep the air control fully open until the fire is well-established.

OPERATE THE INSERT ONLY WITH THE DOOR FULLY CLOSED. OPERATION WITH THE DOOR PARTIALLY OPEN MAY RESULT IN OVER-FIRING. IF THE DOOR IS LEFT PARTIALLY OPEN, GAS AND FLAME MAY BE DRAWN OUT OF THE STOVE CREATING SAFETY RISKS FROM BOTH FIRE AND SMOKE.

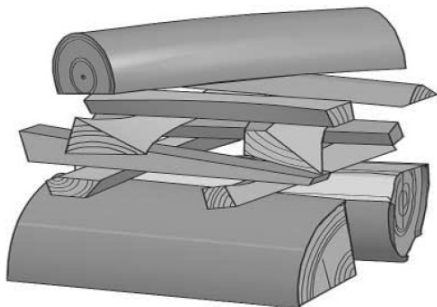

Figure 17. Top-down Firebuilding

Adding Fuel to the Fire

When reloading the stove while a bed of hot embers still exists, follow this reloading procedure:

- Always wear stove gloves when tending to the fire.
- Push the Air Control Lever to the full open position (far right).
- **Always wait a few seconds before opening the door.** This allows the renewed air circulation to clear unburned gases from the firebox.
- Use a stove tool or poker to distribute the hot embers equally around the firebox.
- Load the fuel, usually with smaller logs first. **Keep logs behind the andirons.** See fig. 16.
- Close the doors and secure the latch.
- Wait 5 – 10 minutes for the fire to re-establish before adjusting the Air Control Lever for the desired heat output. If a thick bed of live coals is present, you may be able to add fuel and immediately set the air control without waiting for the fire to be re-established.

Experiment with a variety of air control settings to determine the best one for your individual circumstances. Remember that fuel characteristics, chimney system condition, building design, and weather conditions all affect the performance of your fireplace insert. In time, you will discover how these elements combine and how you can work with them to achieve satisfactory performance.

Creosote Formation

This appliance is designed to burn wood cleanly and efficiently when operated as described in this manual. However, when wood is burned slowly and at low temperatures, tar and other organic vapors are produced which condense on the relatively cooler chimney flue surfaces to form creosote. Failure to keep the chimney system free of creosote build up could result in a chimney fire.

The creosote that accumulates in the chimney is highly flammable and is the fuel of chimney fires. To prevent chimney fires, it is important to have the chimney flue and connector pipe inspected at least every other month during the heating season and cleaned whenever creosote accumulation of 1/4" or more is evident. A qualified chimney sweep or other authorized service person can provide this service.

It is also important to remember that chimney size, temperature and height all affect draft which in turn affects the formation of creosote. An exterior chimney, whether masonry or prefabricated steel, will be exposed to cold outside temperatures, and consequently, will be more prone to creosote accumulation than an interior flue.

Creosote cont'd.

A chimney flue located within the home interior will benefit from the insulating characteristics of the building itself. Consequently, the flue system will be less conducive to condensation of unburned gases and minimal creosote accumulation will result..

As a general rule, try to avoid burning the insert at the lowest air control settings. Although a low setting will prolong burn time, it may also result in incomplete combustion. In reducing the fire intensity, draft is weakened and the chimney flue cools. This, together with the increase in unburned gases, leads to rapid creosote accumulation.

Blower Operation

Access the blower control panel by lifting the cast iron lower grille up off the insert.

The dual blowers will enhance heat circulation around the firebox and out into the room. In the Automatic setting, the blowers are controlled by a heat activated switch (snapstat) that will only function when the speed control is ON. After the fire has been burning for a time, the snapstat will react to the heat and activate the blowers. Conversely, the blower will continue to operate until the snapstat cools as the fire wanes. The blowers will then shut off automatically.

The Manual setting overrides the snapstat functionality allowing blower operation regardless of temperatures.

For best performance, do not turn the switch on until after the fire is well-established.

If the blower is not needed, place the blower control switch in the OFF position.

See Blower Maintenance section on page 19 for further information.

■ THIS BLOWER MUST BE ELECTRICALLY GROUNDED IN ACCORDANCE WITH LOCAL CODES OR, IN THE ABSENCE OF LOCAL CODES, WITH THE CURRENT ANSI/ NFPA 70, NATIONAL ELECTRICAL CODE OR CSA C22.1-CANADIAN ELECTRICAL CODE.

■ THIS UNIT IS SUPPLIED WITH A THREE-PRONG (GROUNDING) PLUG FOR PROTECTION AGAINST SHOCK HAZARD AND SHOULD BE PLUGGED DIRECTLY INTO A PROPERLY GROUNDED THREE-PRONG RECEPTACLE. DO NOT CUT OR REMOVE THE GROUNDING PRONG FROM THE PLUG.

■ ALWAYS DISCONNECT THE POWER SUPPLY WHEN PERFORMING ANY SERVICE ON THE FIREPLACE INSERT.

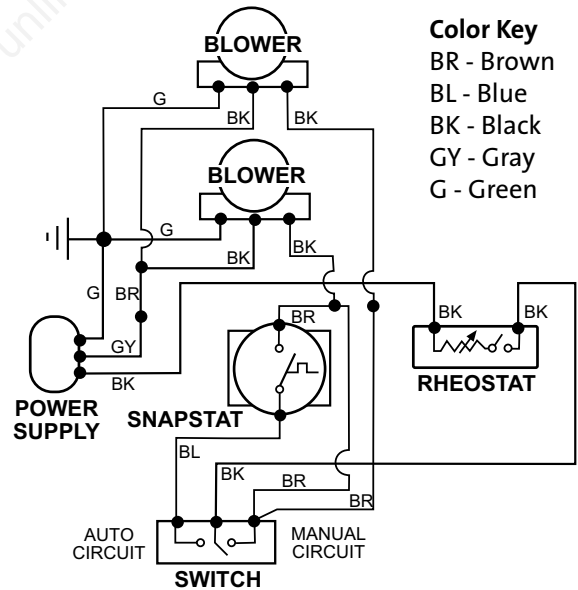

NOTE: Terminals and switch markings are on opposite ends of the switch. See below.

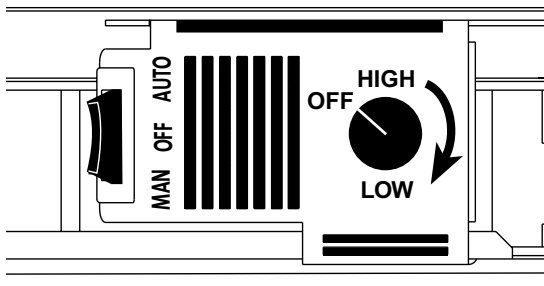
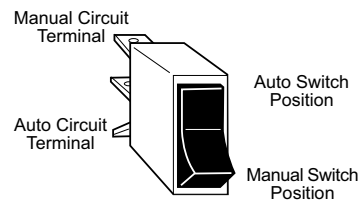

Figure 18. Blower and speed controls.

Figure 19. C 350 Wiring diagram.

Maintenance

Ash Removal

Always wear stove gloves when handling ashes.

Ash removal will be required periodically depending on how frequently the stove is used. Use a steel ash shovel and metal container with a tight-fitting lid. **NEVER USE A PAPER OR PLASTIC BAG AS AN ASH RECEPTACLE.**

The container of ashes should be placed on a noncombustible floor or on the ground, well away from all combustible materials, pending final disposal. If the ashes are disposed of by burial in soil or otherwise dispersed, they should be kept in the closed container until all coals and cinders have thoroughly cooled.

Glass Care

Cleaning

Occasionally it will be necessary to clean the carbon deposits and fly ash off of the glass. If deposits are allowed to remain on the glass for an extended period of time, the glass may become etched and cloudy.

Creosote deposits should burn off during the next hot fire.

1. The glass must be **COMPLETELY COOL**.
2. Only use a cleaner that is specifically designed for this purpose. **DO NOT USE ABRASIVE CLEANING AGENTS.** The use of abrasives will damage the glass, leaving a frosted surface. Crumpled newspaper is an especially good cleaning material.
3. Rinse and dry glass completely before lighting a fire.

Glass Replacement

Always operate the doors slowly and cautiously to avoid cracking or breaking the glass. Never use the door to push wood into the firebox. If the glass becomes cracked or broken follow the replacement procedure below.

IMPORTANT:

NEVER OPERATE THE STOVE WITH A CRACKED OR BROKEN GLASS PANEL. Replace glass only with part # 156069 specifically designed for the Jøtul C 350 Winterport Fireplace insert. Do not use substitutes. Replacement glass can be ordered from your Jøtul dealer.

1. Remove the door from the stove and place on a flat surface.
2. First loosen and then carefully remove all of the glass clips from the inside of the door. See fig. 20.
3. Remove all pieces of the glass panel and gasketing.
4. Remove all remaining debris from the glass area using a wire brush.
5. Apply a small bead of gasket/stove cement and the new gasket. Do not overlap the ends of the gasket rope.
6. Orient the glass with the IR Coating label facing out. Hold the glass at an angle to see the word "COATED" located at the lower edge. This side should face out when placed in the door. Center the new glass panel over the gasket and loosely reinstall the glass clips. Tighten the clips, alternating at opposite corners. Avoid applying uneven pressure on the glass..
7. It may be necessary to retighten the glass clips after the stove has burned and the gasketing has seated.

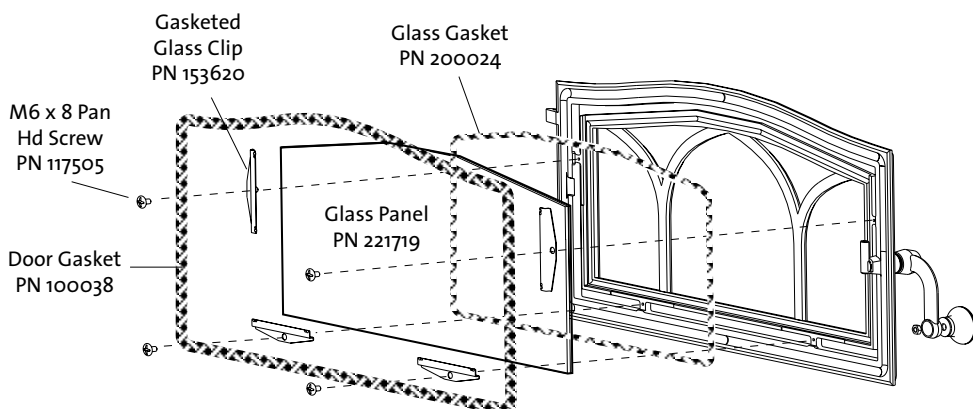

Figure 20.
Replacing the door glass and gaskets.

General Maintenance

Chimney System

The Jøtul C 350 Fireplace Insert is designed to burn cleanly and efficiently when used according to the guidelines in this manual. In order to maintain proper performance, **you should inspect the chimney and chimney connector at the beginning of each heating season and then every other month during the heating season.** Clean the chimney whenever creosote and fly ash accumulation exceeds 1/4 inch in any part of the system.

Chimney brushes are available from your local Jøtul dealer or hardware supply store. Your dealer can also refer you to a reputable, professional chimney sweep who will have all the equipment to ensure a complete and proper job. Failure to keep the chimney system free of creosote and build-up could result in a serious chimney fire.

Regular maintenance will assure proper performance and prolong the life of your fireplace insert. The following procedures do not take long and are generally inexpensive. When done consistently, they will help increase the life of your fireplace insert and assure satisfactory performance.

- Thoroughly clean the insert. Enamel surfaces should be cleaned with a moist cloth and polished dry.
- Empty firebox of all soot and ashes. Never use a household vacuum cleaner to remove ashes. Only a shop vac with a metal container is acceptable and only when you are certain the ashes are cold.
- Inspect the firebox using a utility light inside and out for cracks or leaks. Replace all cracked bricks and repair leaks with furnace cement.

Removing the Insert for Cleaning

U.S. Direct-connection Only:

1. Disconnect the blower power cord from its outlet.
2. Open the firebox door and pull the insert out enough to disengage the surround panel assemblies by lifting up off of the brackets.
3. Remove the three screws that attach the flue connector to the flue collar, and disengage the it from the insert.
5. Pull the firebox and cabinet forward as a unit. The flue connector, liner, and chimney can now be inspected and cleaned.
6. See the Installation section of this manual for reassembly procedures.

Canada Installations (Full Reline):

The chimney can be swept directly into a bucket placed under the flue outlet, with removal of the two cast iron baffle plates.

1. Push up on the Left Baffle to disengage its locating boss from the Secondary Air Tube.
2. Slide the Secondary Air Tube to one side to disengage it from the opposite side Air Channel and remove it from the firebox.
3. Lift the Right Baffle up and forward off of the rear and side support shelves.
4. Repeat with the Left Baffle.
5. Re-assemble in the reverse order, being sure to engage the nub on the Left Baffle with the hole in the Secondary Air Tube.

Gaskets

Check door and glass gaskets for seal integrity. The gaskets should be soft enough to be somewhat resilient to the touch. Over time, gaskets will compress and harden. Replace worn-out or hardened gaskets with the appropriate size material available from your local Authorized Jøtul Dealer.

To check the seal of the front doors, close and latch the doors on a dollar bill and slowly try to pull the dollar bill free. The seal is too loose if the bill can be easily removed. Adjust the door latch and test again.

Gasket Replacement

See the chart below for replacement gasket specifications. See also fig. 20 for locations.

1. Remove the old gasket material with a pliers and thoroughly clean the channel with a wire brush.
2. Lay out the new gasket around the channel to determine length. Trim the gasket to leave 1" excess.
3. Apply a small bead of furnace cement in the channel.
4. Lightly press the new gasket into the channel, being careful to avoid compressing or stretching it. Trim the gasket further as necessary to allow the tail end to slightly overlap the other end.
5. Wait ten minutes to allow the cement to set and then close and latch the doors. Reopen the doors and, using a damp cloth, wipe away any excess cement that may be squeezed out from under the gasket.

Blower Maintenance

In order to ensure that the blower delivers many years of reliable performance, you should inspect it regularly and clean it of any household dust and debris that may have accumulated. This is particularly important if there are any pets in the home.

Always disconnect the blower from its power source before cleaning. Use a vacuum with soft brush attachment to clean the blower housing and compartment, as well as the area under the insert firebox.

Replacement Gaskets

Glass			
LD .250 Fiberglass Rope	52"		200024
Door			
LD .350 Fiberglass Rope	70"		100034
Front			
LD .360 Fiberglass Rope	78"		100034
Air Manifold, Outer			
LD .250 SA Fiberglass Rope	30"		129644
Air Manifold, Inner			
.125 x 8 mm Flat SA	20"		127215

Jøtul C 350 Winterport Illustrated Parts Diagram

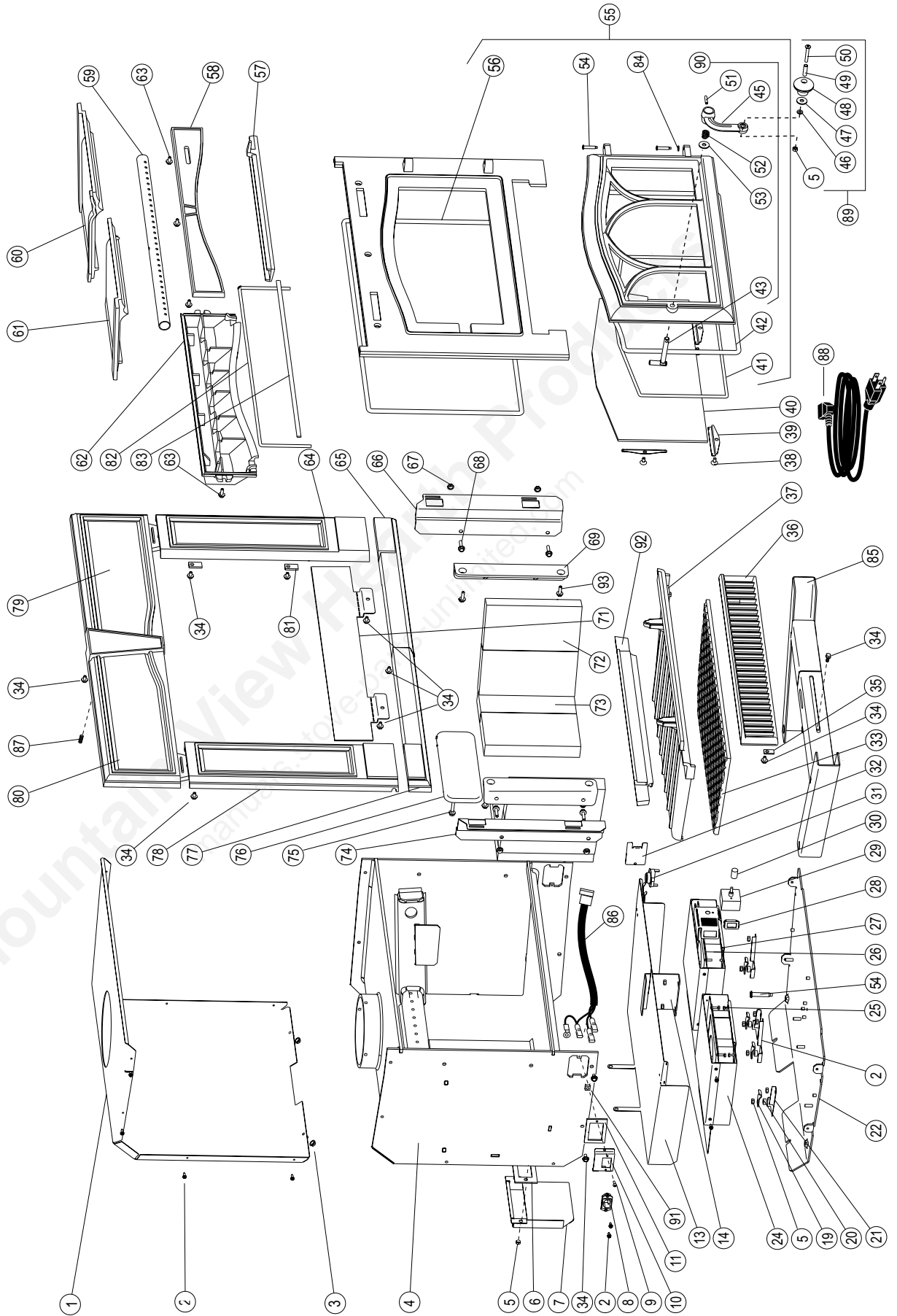

Use only genuine Jøtul replacement parts.
Do not substitute parts from any other manufacturer. See
your local Authorized Jøtul Dealer or contact us directly:

Jøtul North America
55 Hutcherson Dr.
Gorham, Maine 04038

Figure 21.

Jøtul C 350 Winterport Parts List

No.	Description	Part Number
1.	Rear Shroud	220904
2.	Screw, #8 x 5/8" Hex Slit	117917
3.	Nut, M6 Flange	117968
4.	Firebox Assembly	220909
5.	Nut, M6 Hex	9930
6.	Gasket, Secondary Air Channel	221750
7.	Secondary Air Channel	221721
8.	AC Power Receptacle	221790
9.	Screw, #8 x .62 Pan Head Type A SMS	118057
10.	Receptacle Mounting Plate	221798
11.	Receptacle Mounting Plate Gasket	221799
12.	Bolt, M6 x 12 Hex Head Flange	117130
13.	Blower Shield Assembly	221959
14.	Firebox Support	221759
19.	Blower Attachment Clip	121041
20.	Spacer, .250 x .500	117994
21.	Guide, Left Blower	221764
22.	Shroud Assembly, Base	220905
23.	Guide, Right Blower	221763
24.	Left Blower Assembly	156047
25.	Nut, M4 Hex	117922
26.	Right Blower Assembly w/o Rheostat	156048
27.	Right Blower Base Assembly	221965
28.	Rocker Switch	220703
29.	Rheostat, Solid-state Variable / Rplcmt Kit	156051
30.	Rheostat Control Knob	221788
31.	Snap-stat, 110°F - 10°F	221113
32.	Receptacle Cover Plate	221967
33.	Insulating Panel, Grate	221784
34.	Bolt, M6 x 10 Hex Head Serr. Flange	9962
35.	Hang Tab	129680
36.	Control Door, Matte Black Paint, inc. hardware	156052
	Control Door, Blue Black Enamel	156070
	Control Door, Jøtul Iron Paint	156053
37.	Bottom Grate Plate	104277
38.	Screw, M6 x 8 Pan Head	117505
39.	Glass Clip	153620
40.	Glass Panel, Ceramic IR Coated	221719
41.	Rope Gasket, Fiberglass - LD .250 x 52" - Glass	200024
42.	Rope Gasket, Fiberglass - LD .360 x 70" - Door	100038
43.	Door Latch Bolt	221720
45.	Cast Door Handle	10371292
46.	Washer	117947
47.	Insulating Washer	124853
48.	Wooden Door Knob	126244
49.	Door Handle Sleeve	126229
50.	Bolt, M6 x 40 PHP	117796
51.	Roll Pin, 5 mm x 24 mm	117733
52.	Door Handle Compression Spring	126164
53.	Washer, Door Handle	117587
54.	Hinge Pin	127075
55.	Front Asy. Complete, inc. Door / Matte Black Paint	156054
	Front Asy. Complete, inc. Door / Blue Black Enamel	156058
	Front Asy. Complete, inc. Door / Jøtul Iron Paint	156074

No.	Description	Part Number
56.	Rope Gasket, Fiberglass LD .360 x 78" - Frnt Plate	100038
57.	Air Slider, Matte Black Paint	156092
	Air Slider, Nickel Plated	156094
	Air Slider, Jøtul Iron Paint	156093
58.	Air Cover Plate, Matte Black Paint	156076
	Air Cover Plate, Blue Black Enamel	156059
	Air Cover Plate, Jøtul Iron Paint	156077
59.	Secondary Air Tube	221753
60.	Baffle Plate, Right	104296
61.	Baffle Plate, Left	104295
62.	Airwash Manifold, inc. gasket / Matte Black Paint	156090
	Airwash Manifold, inc. gasket / Jøtul Iron Paint	156091
63.	Bolt, M6 x 16 Flange Head	99625
64.	Surround Leg, Right - Matte Black Paint	156084
	Surround Leg, Right - Blue Black Enamel	156063
	Surround leg, Right - Jøtul Iron Paint	156085
65.	Trim, Bottom Right - Matte Black Paint	156088
	Trim, Bottom Right - Blue Black Enamel	156065
	Trim, Bottom Right - Jøtul Iron Paint	156089
66.	Surround Support, Right	221733
67.	Nut, M8 Flange	117881
68.	Bolt, M8x 25 Flange Hex	117876
69.	Front Plate Attachment Bracket (2)	156792
71.	Bracket, Bottom Trim	221770
72.	Brick, 4.5 x 8.5 - Refractory	221751
73.	Brick, 3.5 x 8.5 - Refractory	221752
74.	Surround Support, Left	221732
75.	Bolt, M6 x 40 Hex Head / SS	117997
76.	Brick Retainer, Cast	10430092
77.	Trim, Bottom Left - Matte Black Paint	156086
	Trim, Bottom Left - Blue Black Enamel	156064
	Trim, Bottom Left - Jøtul Iron Paint	156087
78.	Surround Leg, Left - Matte Black Paint	156082
	Surround Leg, Left - Blue Black Enamel	156062
	Surround Leg, Left - Jøtul Iron Paint	156083
79.	Surround Panel, Breastplate, Right - Matte Black	156080
	Surround Panel, Breastplate, Right - Blue Black	156071
	Surround Panel, Breastplate, Right - Jøtul Iron	156081
80.	Surround Panel, Breastplate, Left - Matte Black	156078
	Surround Panel, Breastplate, Left - Blue Black	156061
	Surround Panel, Breastplate, Left - Jøtul Iron	156079
81.	Hang Tab	224144
82.	Rope Gasket, Fbrgls - LD .250 SA - Outer Air Mnfld, 30"	129644
83.	Gasket, Flat - .125 x 8 mm - Inner Air Manifold, 20"	127215
84.	Washer, .062 x .500	117947
85.	Riser Bar Assembly, Replacement	156072
86.	AC Harness w/ Receptacle, Replacement	156057
87.	Set Screw, M6 x 10 mm - Surround adjustment	04-117720
88.	Blower Power Cord, HT - Offset Angle	222093
89.	Wooden Knob Replacement Kit	151991
90.	Handle Asy, Complete / Matte Black Paint	156320
	Handle Asy, Complete / Nickel Plated	156321
91.	#8 Spring Nut	118056
92.	Fettle / Matte Black Paint	10432092
	Fettle / Jøtul Iron Paint	10432085
93.	Bolt, M8 x 20, Flange Hex	117875

Appendix A

Door Knob Installation

The Door Knob components are included in a separate bag contained within the Miscellaneous Kit included with the firebox. Install the parts in the order shown in fig. 22. Phillips screwdriver required.

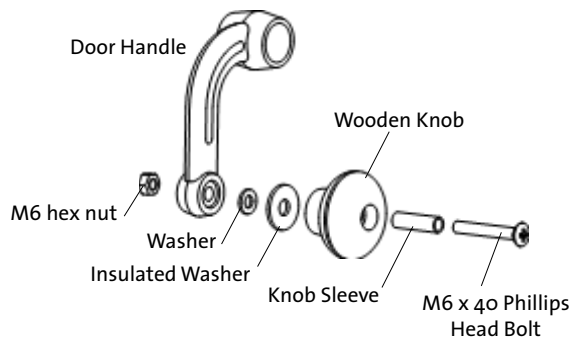

Figure 22. Door knob assembly.

Baffle Plate Removal

The baffle assembly is easily removable following these steps:

- 1) The Secondary Air Tube must be removed before the cast iron baffles. Push up on the Left Baffle to disengage the Air Tube from the Locator Boss on the underside of the baffle. The air tube can then be slid to one side to disengage one end from the side manifold. The baffles will continue to be supported by the back ledge and the side manifolds.
- 2) Lift and remove the Right Baffle.
- 3) Lift and remove the Left Baffle.

Reassemble in the opposite order.

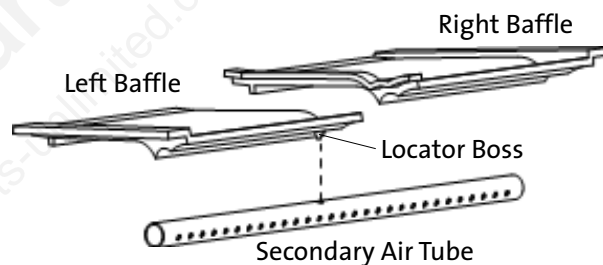

Figure 23. Baffle assembly.

Jøtul C 350 Winterport Limited Warranty

Effective January 1, 2013.

This warranty policy applies to wood-burning products identified by Jøtul and Scan trade names, as set forth below.

A. LIMITED LIFETIME WARRANTY, parts only:

Jøtul North America Inc. (JØTUL) warrants, to the original retail purchaser, that those baffle and air manifold components of the Jøtul Stove or Fireplace Insert specified above will be free of defects in material and workmanship for the life of the product. This warranty is subject to the terms, exclusions and limitations set forth below.

B. LIMITED FIVE YEAR WARRANTY - Cast Iron and Steel Components:

JØTUL warrants, to the original retail purchaser, that those components of the Jøtul Stove or Fireplace Insert specified above will be free of defects in material and workmanship for a period of five (5) years from the date of purchase. This warranty is subject to the terms, exclusions and limitations set forth below.

C. LIMITED TWO YEAR WARRANTY - Enamel Finish:

JØTUL warrants, to the original retail purchaser, the enamel finish on cast iron components of the Jøtul Stove or Fireplace Insert specified above against peeling or fading for a period of two (2) years from the date of purchase. This warranty is subject to the terms, exclusions and limitations set forth below.

D. LIMITED ONE YEAR WARRANTY - Electrical Components (blowers, thermostatic switches):

JØTUL warrants, to the original retail purchaser, that those components of the Jøtul Stove or Fireplace Insert specified above will be free of defects in material and workmanship for a period of one (1) year from the date of purchase. This warranty is subject to the terms, exclusions, and limitations set forth below:

JØTUL will repair or replace, at its option, any of the above components determined by JØTUL to be covered by this warranty. You must, at your own expense, arrange to deliver or ship the component to an authorized Jøtul dealer and arrange for pickup or delivery of the component after repairs have been made. If, upon inspection, JØTUL determines that the component is covered by this warranty, the repair or replacement will be made as set forth above. This warranty is not transferable and is extended only to, and is solely for the benefit of, the original retail purchaser of the Jøtul Stove or Fireplace Insert. This paragraph sets forth the sole remedy available under this warranty in the event of any defect in the Jøtul Scan Stove or Fireplace Insert.

The warranty period for any replaced component will be the remaining unexpired portion of the warranty period for the original component. Please retain your dated sales receipt in your records as proof of purchase.

EXCLUSIONS AND LIMITATIONS

NOTICE: This warranty is void if installation or service is performed by someone other than an authorized installer or service agency, or if installation is not in conformance with the installation and operating instructions contained in this owner's manual or local and/or national fire and building regulations. A listing of local authorized installers, service agencies and gas suppliers can be obtained from the National Fireplace Institute at <http://www.nficertified.org/>.

This warranty does not cover the following:

- 1) Repair or replacement of parts that are subject to normal wear and tear during the warranty period or to parts that may require replacement in connection with normal maintenance. These parts include paint, gaskets, burn plates, ceramic insulation blankets, skamol baffles and panels, firebricks, fire grates, or glass (Ceramic glass is warranted against thermal breakage only).
- 2) Damage due to incorrect installations not in conformance with the installation instructions contained in this owner's manual or local and/or national fire and building regulations.
- 3) Damage, including damage to enamel surfaces, caused by improper operation, over-firing, and/or misuse. Improper operation, such as burning the stove with the ash door open, can damage the stove. Over-firing occurs when any part of the stove glows red. Over-firing can also be identified by warped plates, rust-colored cast iron, paint

pigment that has turned dusty white, or bubbling, cracking and discoloration of the enamel finish. Misuse includes, without limitation, use that is not in conformance with the operating instructions contained in this owner's manual.

- 4) Damage to enamel finish including chipping, mechanical or chemical abrasion, crazing, staining, or rust caused by high humidity or salt air environments.
- 5) Damage from or repair of rust. Use of a stove-top steamer can cause rust.
- 6) Damage due to service performed by an installer or service agency, unless otherwise agreed to in writing by JØTUL.
- 7) Damage caused by unauthorized modification, use or repair.
- 8) Costs incurred by travel time and/or loss of service.
- 9) Labor or other costs associated with the repair of components beyond the warranty period.
- 10) Damage incurred while the Jøtul Stove or Fireplace is in transit.

IN NO EVENT SHALL JØTUL, ITS PARENT COMPANY, SHAREHOLDERS, AFFILIATES, OFFICERS, EMPLOYEES, AGENTS OR REPRESENTATIVES BE LIABLE OR RESPONSIBLE TO YOU FOR ANY SPECIAL, INDIRECT, INCIDENTAL, CONSEQUENTIAL, PUNITIVE OR OTHER SIMILAR DAMAGES, INCLUDING, BUT NOT LIMITED TO, LOST PROFITS, LOST SALES, INJURY TO PERSON OR PROPERTY, OR DAMAGES TO A STRUCTURE OR ITS CONTENTS, ARISING UNDER ANY THEORY OF LAW WHATSOEVER. ALL IMPLIED WARRANTIES, INCLUDING THE IMPLIED WARRANTIES OF MERCHANTABILITY AND FITNESS FOR A PARTICULAR PURPOSE, OR OTHERWISE, ARE LIMITED IN DURATION TO THE LENGTH OF THIS WRITTEN WARRANTY. EXCEPT AS EXPRESSLY SET FORTH HEREIN, JØTUL MAKES NO ORAL, WRITTEN OR OTHER WARRANTY WITH RESPECT TO JØTUL STOVES OR FIREPLACES.

Some states do not allow the exclusion or limitation of incidental or consequential damages, or limitations on the length of implied warranties. Therefore, the above exclusions or limitations may not apply to you. This warranty gives you specific legal rights, and you may have other rights, which vary from state to state.

JØTUL reserves the right to discontinue, modify or change the materials used to produce the Jøtul Stove or Fireplace Insert. JØTUL shall have the right to replace any defective component with substitute components determined by JØTUL to be of substantially equal quality and price.

The dollar value of JØTUL's liability for breach of this warranty shall be limited exclusively to the cost of furnishing a replacement component. JØTUL may at its discretion discharge all obligations by refunding the wholesale price of any defective part or appliance. JØTUL shall in no event be liable for any special, indirect or consequential damage of any nature which is in excess of the original wholesale purchase price of the product. JØTUL shall not in any event be liable for the cost of labor expended by others in connection with any defective component. Any costs or expenses beyond those expressly assumed by JØTUL under the terms of this warranty shall be the sole responsibility of the owner(s) of the Jøtul Stove or Fireplace.

No dealer, distributor, or other person is authorized to modify, augment, or extend this limited warranty on behalf of JØTUL. NO MODIFICATION OR CHANGE TO THIS WARRANTY WILL BE EFFECTIVE UNLESS IT IS MADE IN A WRITTEN DOCUMENT MANUALLY SIGNED BY AN AUTHORIZED OFFICER OF JØTUL.

An authorized installer may have been provided with certain information related particularly to the Jøtul Stove or Fireplace; however, no authorized installer or other person who may service the appliance is an agent of JØTUL. No inference should be made that JØTUL has tested, certified, or otherwise pronounced any person as qualified to install or service the appliance. JØTUL shall not be liable or otherwise responsible for any error or omission by a person installing or servicing a Jøtul Stove or Fireplace Insert.

If you believe your Jøtul Stove or Fireplace Insert is defective, you should contact your nearest authorized Jøtul dealer, who will process a warranty claim. IN ORDER TO QUALIFY FOR WARRANTY COVERAGE, JØTUL MUST RECEIVE NOTICE OF A POSSIBLE DEFECT WITHIN SIXTY (60) DAYS OF THE DATE THE DEFECT IS FIRST DISCOVERED, OR REASONABLY COULD HAVE BEEN DISCOVERED.

This warranty is given by Jøtul North America, Inc.,
55 Hutcherson Drive, Gorham, Maine 04038 USA

138376_Rev_P
May 2016

This appliance must be installed in conformance with local and national building regulations. It is important that these instructions be carefully read and understood before beginning the installation. Jøtul pursues a policy of continual product development. Consequently, products may differ in specification, color or type of accessories from those illustrated or described in various publications.

Jøtul North America Inc.

55 Hutcherson Dr.
Gorham, Maine 04038
USA

Jøtul AS

P.O. Box 1411
N-1602 Fredrikstad,
Norway

www.jotul.us

