

Jøtul C 550 CB Rockland  
Fireplace Insert

# Jøtul C 550 CB Rockland Fireplace Insert

*Traditional Lattice*

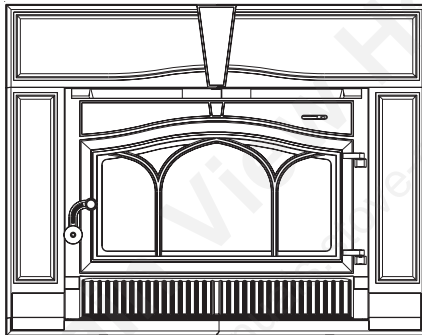

*Clean Face*

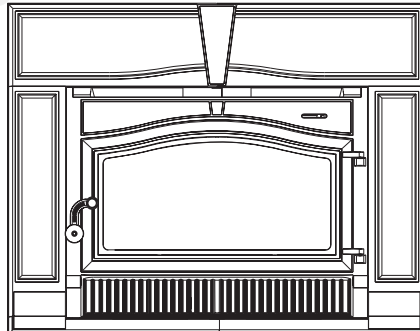

## Installation and Operating Instructions for the United States & Canada

V2

- The Jøtul C 550 Rockland fireplace insert is listed to burn solid wood only. Do not burn any other fuels.
- Read this entire manual before you install and use this appliance.
- Save these instructions for future reference and make them available to anyone using or servicing the fireplace insert.
- This wood heater requires periodic inspection and repair for proper operation. See this manual for specific maintenance information. It is against federal regulations to operate this wood heater in a manner inconsistent with the operating instructions in this owner's manual.

# Table of Contents

## Standards and Safety Notices

Standards / Codes ..... 3  
 Combustion Specifications ..... 3  
 Safety Notices ..... 4  
 Preparation ..... 4  
 Unpacking the Firebox ..... 4

## Specifications

Dimensions ..... 5

## Installation

Masonry Fireplace Requirements ..... 6  
 Factory-built Fireplace Requirements ..... 6  
 Chimney Height..... 6  
 Hearth Protection ..... 7  
 Clearance to Combustibles ..... 8-9  
 Chimney Connection ..... 10  
 Firebox Installation ..... 12  
 Surround Assembly ..... 13

## Operation

Combustion Efficiency ..... 14  
 CO Emissions ..... 14  
 Wood Fuel and Performance ..... 14  
 Functionality ..... 14  
 Break-in Procedure ..... 15  
 Air Control Settings..... 15  
 Starting / Maintaining the Fire..... 16  
 Adding Fuel ..... 16  
 Formation of Creosote ..... 16  
 Blower Operation ..... 17

## Maintenance

Ash Removal ..... 18  
 Glass Care..... 18  
 Chimney System ..... 19  
 Gaskets..... 19

## Illustrated Parts Breakdown

Exploded View ..... 22  
 Parts Listing ..... 23

## Appendix

Alternate Hearth Protection ..... 24  
 Leg Leveler Installation ..... 24  
 Door Knob Assembly ..... 24  
 Blower Flex Conduit Kit Installation ..... 25

Warranty Statement ..... 25

### For Your Records...

Record the following information to help your dealer determine what you will need should your fireplace ever require parts or service. The serial number and manufacturing date are indicated on the permanent label located in the blower compartment under the firebox. You may also wish to attach your sales receipt to this manual for future reference.

Model: Jøtul C 550 Rockland Fireplace Insert

Serial Number: \_\_\_\_\_

Purchase Date: \_\_\_\_\_

Dealer: \_\_\_\_\_

Phone: \_\_\_\_\_

Installed by: \_\_\_\_\_

Date: \_\_\_\_\_

### PLEASE NOTE:

**IT IS NORMAL FOR SMOKE AND ODOR TO OCCUR DURING THE INITIAL STAGES OF OPERATION, DEPENDING UPON TEMPERATURES GENERATED OVER TIME. THIS "CURING" CONDITION CAN BE ALLEVIATED BY PROMOTING FRESH AIR CIRCULATION WITHIN THE IMMEDIATE VICINITY OF THE APPLIANCE.**

NATIONAL  
FIREPLACE  
INSTITUTE®



CERTIFIED  
www.nficertified.org

We recommend that our gas hearth products be installed and serviced by professionals who are certified in the U.S. by the National Fireplace Institute® (NFI) as NFI Gas Specialists.

## Standards

The Jøtul C 550 CB Rockland fireplace insert has been tested and listed to the following standards:

U.S: ANSI/UL 1482-2011

Canada: CAN/ULC-5627-00

Certified Safety Tests performed by:

ITS, Intertek Testing Services

Middleton, Wisconsin

Manufactured by:

Jøtul North America

55 Hutcherson Drive

Gorham, Maine 04038-2644

## Combustion Specifications

### Jøtul C 550 Rockland

**Heat Output Range:**<sup>1</sup> 11,700 to 34,900 BTU/hr.  
Max. Heat Output: 65,000 BTU/hr.

**Heating Capacity:**<sup>2</sup> Up to 1,700 sq. ft.  
**Maximum Burn Time:**<sup>2</sup> Up to 9 hours

<b>Combustion Efficiency:</b> <sup>3</sup>	<b>HHV</b>	<b>LHV</b>
	71.48%	77.28%
<b>CO Emissions:</b> <sup>4</sup>	141.62 g/hr	
<b>Particulate Emissions:</b> <sup>5</sup>	4.5 g/hr	

**Fuel:** Up to 24" Logs (610 mm)

See the Operation section of this manual for important information regarding the safe, proper, and most efficient operation of your stove.

<sup>1</sup> *Heat Output Range* results are determined during specific emissions tests established by the EPA.

The *Maximum Heat Output* value is representative of a more frequent re-fueling cycle than specified in the EPA High Heat Output test method.

<sup>2</sup> *Heating Capacity and Maximum Burn Time* will vary depending on design of home, climate, wood type and operation

<sup>3</sup> *High Heat Value and Low Heat Value* are obtained per CSA B415.1-10 test method. HHV calculation encompasses all products of combustion, including water condensation. LHV calculation includes water in its vapor state. Simply put, HHV assumes all the water component is in a liquid state (condensed) at the end of combustion and that heat recovered from condensation can be put to use.

<sup>4</sup> *Carbon Monoxide Emissions* rate results from Test Method CSA B415.1-10.

<sup>5</sup> *Particulate Emissions* rate is obtained using EPA Test Method 28-5H.

### WARNING !

**THIS WOOD HEATER HAS A MANUFACTURER-SET MINIMUM LOW BURN RATE THAT MUST NOT BE ALTERED. IT IS AGAINST FEDERAL REGULATIONS TO ALTER THIS SETTING OR OTHERWISE OPERATE THIS WOOD HEATER IN A MANNER INCONSISTENT WITH OPERATING INSTRUCTIONS IN THIS MANUAL.**

**This heater meets the 2015 U.S. Environmental Protection Agency's emission limits for wood heaters manufactured after May 15, 2015. This appliance is not approved for sale after May 15, 2020.**

## Check Building Codes

When installing, operating and maintaining your Jøtul C 550 CB fireplace insert, follow the guidelines presented in these instructions, and make them available to anyone using or servicing the stove.

**In the U.S.**, the National Fire Protection Association's Code, NFPA 211, *Standards for Chimneys, Fireplaces, Vents and Solid Fuel Burning Appliances*, or similar regulations, may apply to the installation of a solid fuel burning appliance in your area.

**In Canada**, the guideline is established by the CSA Standard, CAN/CSA-B365-M93, *Installation Code for Solid-Fuel-Burning Appliances and Equipment*.

**THE JOTUL C 550 CB ROCKLAND FIREPLACE INSERT IS NOT APPROVED FOR USE IN MOBILE HOMES.**

### NOTE:

**CONSULT THE AUTHORITY HAVING JURISDICTION IN YOUR LOCALE (SUCH AS MUNICIPAL BUILDING DEPARTMENT, FIRE DEPARTMENT, FIRE PREVENTION BUREAU, ETC.) BEFORE INSTALLATION TO DETERMINE THE NEED TO OBTAIN A PERMIT.**

## Safety Notices

- **BURN SOLID WOOD FUEL ONLY. DO NOT BURN ANY OTHER FUELS.**
- **DO NOT USE CHEMICALS OR FLUIDS TO START THE FIRE. DO NOT BURN Garbage OR FLAMMABLE FLUIDS.**
- **IF THIS ROOM HEATER IS NOT PROPERLY INSTALLED, A HOUSE FIRE MAY RESULT. TO REDUCE THE RISK OF FIRE, FOLLOW THE INSTALLATION INSTRUCTIONS. FAILURE TO FOLLOW THESE INSTRUCTIONS MAY RESULT IN PROPERTY DAMAGE, BODILY INJURY, OR LOSS OF LIFE.**
- **CONTACT THE LOCAL BUILDING OR FIRE OFFICIALS ABOUT RESTRICTIONS AND INSTALLATION INSPECTION REQUIREMENTS IN YOUR AREA. WHEN NOT ADDRESSED IN THIS MANUAL, OR BY LOCAL CODE AUTHORITIES, INSTALLATION SPECIFICATIONS AND REQUIREMENTS DEFER TO NFPA 211 OR CSA B 365.**
- **DO NOT CONNECT THIS FIREPLACE TO ANY AIR DISTRIBUTION DUCT OR SYSTEM.**
- **DO NOT USE GRATES OR ANDIRONS TO ELEVATE THE FIRE. BUILD FIRE DIRECTLY ON THE FIRECHAMBER FLOOR.**
- **EXTREMELY HOT WHILE IN OPERATION! KEEP CHILDREN, CLOTHING AND FURNITURE AWAY. CONTACT WILL CAUSE SKIN BURNS.**
- **NEVER OPERATE THE FIREPLACE WITH A CRACKED OR BROKEN GLASS PANEL.**
- **Install smoke detectors in the living areas and bedrooms of your home. Test them regularly and install new batteries twice annually. When installed in the same room as the stove, a smoke detector should be located as far from the stove as possible to prevent it from sounding when adding fuel to the fire.**
- **Avoid creating a low pressure condition in the room where the stove is operating. Be aware that operation of an exhaust fan or clothes dryer can create a low pressure area and consequently promote flow reversal through the stove and chimney system. The chimney and building, however, always work together as a system - provision of outside air, directly or indirectly to an atmospherically vented appliance will not guarantee proper chimney performance. Consult your local Jøtul authorized dealer regarding specific installation/performance issues.**

## Preparation

We strongly urge you to have your authorized Jøtul dealer install your new Jøtul C 550 CB Fireplace Insert.

- Check with local building officials to determine what permits may be required before installation.
- Notify your insurance company before installing this fireplace.

## Unpacking the Fireplace

All firebox components of the Jøtul C 550 CB Fireplace Insert are contained within the carton on a single pallet. The Surround Kit is packaged separately.

As you unpack the contents, inspect each item for damage. Notify your dealer of any damage such as dents, cracked glass, or broken bricks.

## Contents:

- Firebox Assembly - including Firebricks
- Draw-Down Flue Collar Adaptor - including Pins
- Stove Hardware Bag
  - Fireplace Conversion Notice Plate
  - Blower Power Cord
  - AC Power Receptacle Lead
  - Blower Control Knob
  - Leg Levelers, (2) See Appendix, pg. 22.
  - Door Knob parts See Appendix, pg. 23.

## Tools & Materials Required:

- work gloves
- safety glasses
- tape measure
- Phillips screwdriver
- power drill / 1/8" bit
- flashlight
- High-temperature sealant
- 1" (25 mm) masonry anchors or nails (two)
- 1/4" x 3/4" self-tapping screws (three)
- 10 mm (1/4") open end wrench or socket driver

## Removing the Firebox from Pallet

1. Inspect the firebox assembly for damage and contact your dealer if any is found.
2. The firebox may be lightened by removing the door, firebricks and baffle plates. See page 12 for details on baffle plate removal.
3. The firebox is secured to the pallet by a steel bracket on each side and one screw in the bottom at the front. Use a 1/4 socket to remove these five screws and lift the firebox to disengage the brackets. Discard brackets.
4. Install the Door Knob parts in the order shown in fig. 24, page 24. Install the Blower Control Knob, found in the Miscellaneous Kit bag.

# Specifications

Flue Collar: 6" (152 mm)

Firebox Capacity: 2.08 cu. ft.

Weight: 550 lbs. (249.5 kg)

## Optional Surrounds and Accessories

Steel Wide Surround, 44"x 34" / Matte Black 156432

Trimable Surround, 40"x 32" / for Z-C fireplaces 157324

Stove Gloves 157363

Universal Gasket Kit 157050

Blower Flex Conduit Kit 158002

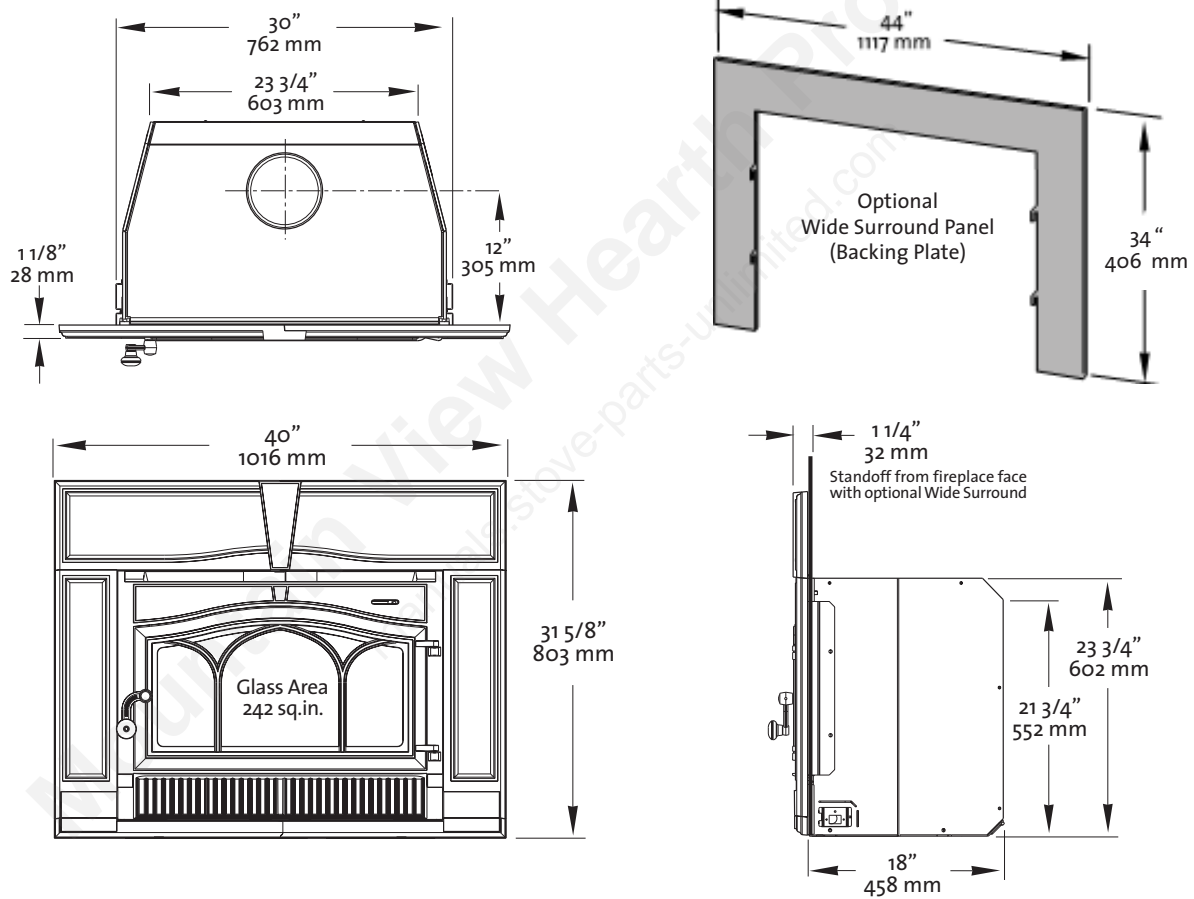

Figure 1. Jøtul C 550 CB Rockland Critical dimensions.

# Installation

## Masonry Fireplace Requirements

The Jøtul C 550 CB is approved for installation into a structurally sound, code-approved, solid masonry fireplace meeting the following conditions:

- The entire fireplace and chimney must be cleaned and inspected to NFPA 211 Level II standards before installation. The system must meet local building code requirements.
- The structure and components must be free of any defects such as cracks or broken bricks or flue tiles. Any damage must be repaired before installation of the fireplace insert.
- Any joint or gap that may exist between the hearth extension/fireplace facing and the fire chamber must be permanently sealed with medium-duty refractory mortar.
- The chimney must have a clay tile liner or a stainless steel liner utilizing a positive connection.
- **Do not remove bricks or mortar from the fireplace or chimney.** However, masonry or steel may be removed from the smoke shelf and adjacent damper frame area to accommodate installation of a chimney liner, provided that their removal will not weaken the structure of the fireplace or chimney, and will not reduce protection for combustible materials.
- **Chimney Height:**  
Minimum - 15 ft. ( 4.57 meters)  
Maximum - 33 ft. (10.5 meters)

## Minimum Fireplace Dimensions

- A: Front Width\* ..... 33" (838 mm)
- B: Height ..... 23 3/4" (603 mm)
- C: Rear Width ..... 24" (610 mm)
- D: Rear Height ..... 22" (559 mm)
- E: Depth.....18" (457 mm)

\*NOTE: Width dimension accommodates clearance for blower power cord routing.

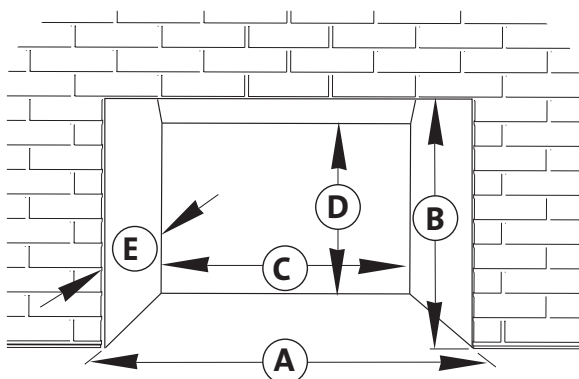

Figure 2. Minimum fireplace dimensions.

## Factory-Built Fireplace Requirements

The Jøtul C 550 CB is approved for installation into a factory-built fireplace meeting the following conditions:

- The factory-built fireplace must be listed per UL 127 or ULC S610.
- The factory-built chimney system must be fully-lined with listed chimney liner meeting type HT requirements (2100°F) per UL 1777 (U.S.) or ULC S635 (CAN). Some liner manufacturers require insulation in order to achieve a UL 1777 or ULC-S635 listing. Check with the liner manufacturer to determine if insulation is required. Insulation is recommended, especially if the chimney is located in a chase outside of the building envelope. The liner must be securely attached to the insert flue collar and the chimney top.
- **THE TOP PLATE OF THE LINER SYSTEM MUST NOT BLOCK AIRFLOW BETWEEN THE COOLING WALLS OF THE FACTORY-BUILT AIR-COOLED CHIMNEY SYSTEM.** These airways **MUST** be left open under all conditions to maintain proper air-cooling of the chimney system. See fig. 3.
- The damper area or fireplace front must be sealed to prevent passage of room air into the chimney cavity.

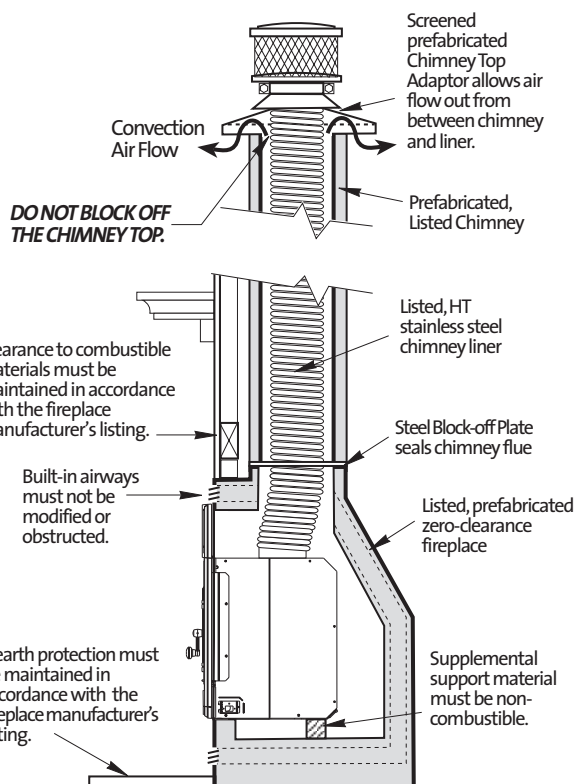

Figure 3. Prefabricated fireplace installation requirements.

### Factory-Built Fireplace Requirements, cont'd.

- The convection chamber/louvers of the zero-clearance fireplace MUST NOT be blocked off. The use of the cast iron surround panels may not be possible in these instances. A custom-built surround panel system may be used provided it does not interfere with air circulation through the convection chamber/louvers.
- Air flow within and around the factory-built fireplace shall not be altered by installation of the insert.
- Alteration of the fireplace in any manner is not permitted; i.e. firebrick or refractory panels MUST NOT be removed in order to accommodate the insert. Exceptions to this are:
  - a. External trim pieces, that do not affect the function of the fireplace, may be removed providing they can be stored on or within the fireplace for reassembly if the insert were to be removed.
  - b. The chimney damper may be removed to install the chimney liner.
- Inserts that project from the factory-built fireplace must be furnished with appropriate means of support. The weight of the insert must not compromise the means of support for the factory-built fireplace.
- Fireplace Conversion Notice 220508 must be permanently attached to the back of the fireplace. This metal label is included in the bag containing this manual.
- Final approval is contingent on the authority having local jurisdiction.

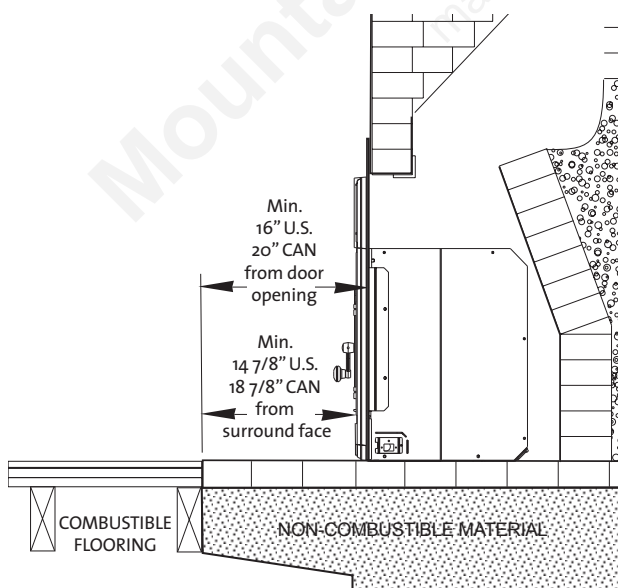

Figure 4. Required hearth protection if flush with combustibles floor materials.

### Hearth Protection Requirements

The floor area in front of fireplace insert must be protected from live sparks and radiant heat.

- **Materials:** Hearth protection must be a noncombustible insulating board such as 1/2" millboard (R-value 1.1), UL listed Type II hearth board, or the equivalent mortared masonry material. Alternate protection must be composed of materials as specified by NFPA 211.

- **Protected Area:**

U.S: 16" Deep x 37" Wide

CAN: 20" Deep x 37" Wide

See exception for 18" depth below.

- **U.S. : Front -**

The protection must extend at least 16 inches forward from the fireplace insert door opening as in fig. 4. (14 7/8" from Surround facing).

- **Canada: Front -**

The protection must extend at least 20 in. forward from the fireplace insert door opening, (18 7/8" from Surround facing).

- **In Canada, Front protection may be reduced to 18" under the following conditions:**

a) it is composed of noncombustible material having an R-value of 1.1 or higher such as 1/2" thick millboard. See Appendix A on page 23 for alternate examples.

b) it is raised a minimum of 2 1/2" and constructed on noncombustible materials in a code-approved masonry fireplace. See fig. 5.

**U.S. & Canada: Side Protection: -** Protection must extend a minimum 18 1/2 in. to both sides of the center line of the insert. See fig 6, A.

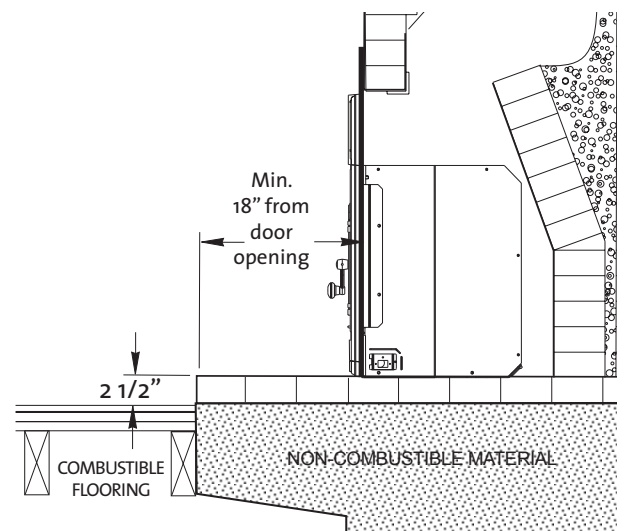

Figure 5. Canada only: Minimum depth with code-approved raised hearth.

## Clearance to Combustible Materials

- There may be no combustible materials located anywhere within 36" (914 mm) of the front of the fireplace insert. This precaution includes items such as drapes or doors that could swing into the area within 36" of the insert.
- Specific clearance (open space) must be maintained between the fireplace insert and combustible materials located above and to the side. See figures 5-6 for minimum dimensions.

# Minimum Clearances for units with serial numbers *after* 11902

Serialized labels are located on the shipping crate, firebox floor, and firebox shroud.

## General Clearances

All clearance specifications are approved for both the U.S. and Canada, except as noted. Clearances are measured from the hearth surface, door opening, or center line as noted below.

### For units with Serial Numbers *after* 11902

- A: Hearth Protection, width from centerline: ..... 18 1/2" (470 mm)
- B: Hearth Protection, forward from door opening: ..... US: 16" / CAN: 20" (508 mm)
- C: To Side Trim, from centerline  
 < 1" thick ..... 21 3/4" (552 mm)  
 > or = to 1" to 6" max. thickness ..... 23" (584mm)
- D: To Side Room Wall, from centerline.....28" (711 mm)
- E: To Top Trim, 1" max. thickness, from hearth: ..... 39" (991 mm)
- F: To Mantel, 3 1/2" max. depth, from hearth: ..... 40" (1060 mm)  
 To Mantel, 11 1/2" max. depth, from hearth ..... 46" (1168 mm)

See fig. 7 for clearances with Mantel Heat Shield.

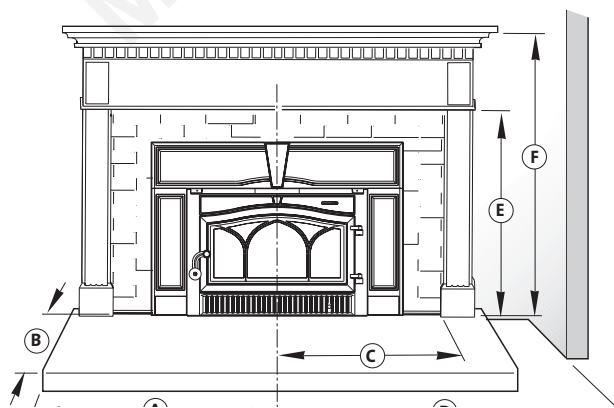

Figure 6. Minimum clearance to combustible materials.

## Mantel Clearances

The installation must conform to the minimum mantel clearances specified in the chart below. These clearances may be reduced with installation of Jøtul Mantel Heat Shield 156448 as specified in the chart. Clearance reduction to mantel construction may also be made in conformance to NFPA 211 or CAN/CSA B365.

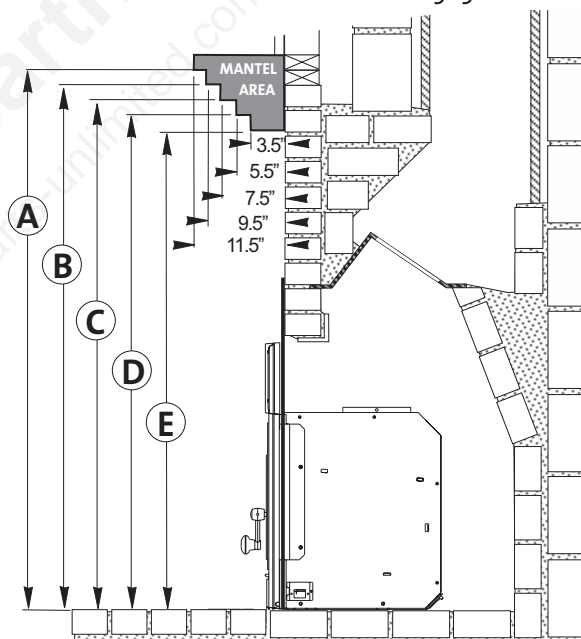

Figure 7. Mantel Clearance Detail - measured from the hearth surface to the lowest mantel surface.

### For units with Serial Numbers *after* 11902

A	B	C	D	E
46"	44 1/2"	43"	41 1/2"	40"
116.8 cm	113 cm	109.2 cm	105.4 cm	101.6 cm

### U.S. & CAN: With Mantel Heat Shield 156448

43"	41 1/2"	40"	38 1/2"	37"*
109.2 cm	105.4 cm	101.6 cm	97.8 cm	94 cm

\* clearance reduction applies to both 3 1/2" Mantel and 1" Top Trim

# Minimum Clearances for units with serial numbers *before* 11903

Serialized labels are located on the shipping crate, firebox floor, and firebox shroud.

These older units may be updated for installation at the reduced clearances on the preceding page with installation of Jøtul C 550 CB Clearance Reduction Kit 157705.

## General Clearances

These clearances are specified for either the U.S. or Canada as indicated. Clearances are measured from the hearth surface, door opening, or centerline as noted below.

### For Stove Serial Numbers *before* 11879

- A: Hearth Protection, width from centerline:  
18 1/2" (470 mm)
- B: Hearth Protection, forward from door opening:  
US: 16" / CAN: 20" (508 mm)
- C: To Side Trim, 1" max. thickness, from centerline .  
US and CAN: 21 3/4" (552 mm)
- D: To Side Room Wall, from centerline:  
US and CAN: 54" (1372 mm)
- E: To Top Trim, 1" max. thickness, from hearth:  
US: 51 3/4" / CAN: 57 1/2" (1460 mm)
- F: To Mantel, 3 1/2" max. depth, from hearth:  
US: 51 3/4" / CAN: 57 1/2" (1460 mm)
- To Mantel, 11 1/2" max. depth, from hearth  
US: 57 3/4" / CAN: 63 1/2" (1613 mm)

See fig. 7a for clearances with Mantel Heat Shield.

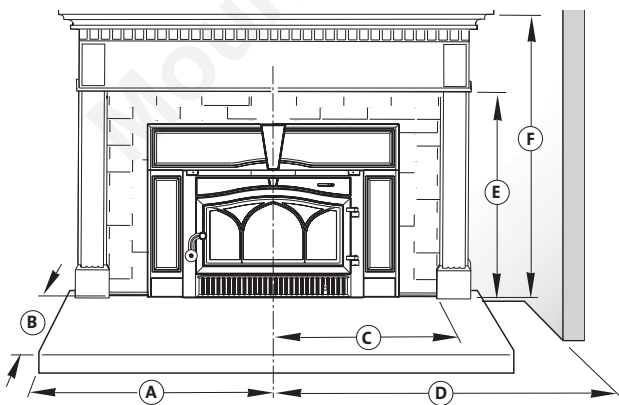

Figure 6a. Minimum clearance to combustible materials.

## Mantel Clearances

The installation must conform to the minimum mantel clearances specified in fig. 7a and the chart below. These clearances may be reduced with installation of Jøtul Mantel Heat Shield 156448 as specified in the chart. Clearance reduction to mantel construction may also be made in conformance to NFPA 211 or CAN/CSA B365.

### For Stove Serial Numbers *before* 11903

	A	B	C	D	E
U.S:	57 3/4"	56 1/4"	54 3/4"	53 1/4"	51 3/4"
CAN:	63 1/2"	62"	60 1/2"	59"	57 1/2"
	161.3 cm	157.4 cm	153.7 cm	150 cm	146 cm
<b>U.S. &amp; CAN: With Mantel Heat Shield 156448</b>					
	48"	46 1/2"	45"	43 1/2"	42"
	127.9 cm	118.1 cm	114.3 cm	110.4 cm	106.6 cm

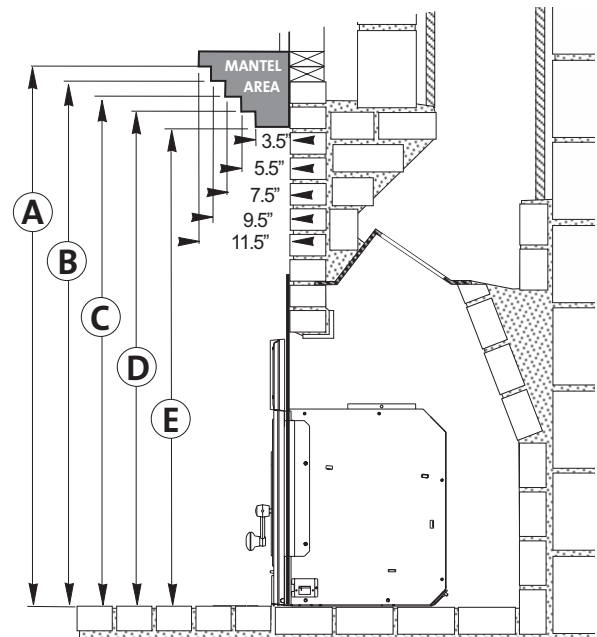

Figure 7a. Mantel Clearance Detail - measured from the hearth surface to the lowest mantel surface.

## Chimney Connection Requirements

The insert must be connected to a code-approved masonry chimney or listed factory-built fireplace chimney with a direct (positive) flue connector into the first chimney liner section. The chimney size should not be less than, nor more than, three times greater than the cross-sectional area of the flue collar.

The optional Jøtul Draw-Down Adaptor Kit 156073 is available to ease connection of the chimney liner with the flue collar.

A positive connection must be made between the fireplace insert and the chimney by one of the following approved methods.

### U.S. Only Requirements:

1. The insert must be connected to a code-approved masonry chimney with a direct (positive) flue connector into the first chimney liner section.
2. The cross-sectional area of the chimney flue may not be less than the cross-sectional area of the flue collar.
3. **A sealed block-off plate must be installed at the damper area of the existing fireplace**, unless the liner is connected directly to the top of the chimney. See fig. 8.
4. **For internal chimneys**, (no sides of the chimney exposed to the outside below the roofline,) a positive connection into the first flue tile is acceptable provided the tile is no larger than 8" x 12".

5. For external chimneys, (one or more sides are exposed to the outside below the roof line, including garages), a positive connection to the first flue tile is acceptable provided the tile is no larger than 8" x 8".
6. **A 6", 7", or 8" stainless steel liner, extending the full height of the chimney, is required** for those installations where the flue tile is greater than 8" x 12" for internal chimneys, or 8" x 8" for external chimneys. In such cases, a damper block-off plate is not required.

### Canada Requirement:

The insert must be installed with a continuous chimney liner of 6" (152 mm) diameter extending from the fireplace insert to the top of the chimney. The chimney liner must conform to the Class 3 requirements of CAN/ULC-S635, Standard for Lining Systems for Existing Masonry or Factory-Built Chimneys and Vents, or CAN/ULC-S640, Standard for Lining Systems for New Masonry Chimneys.

See fig. 9.

Do not use aluminum or galvanized steel pipe for chimney connection components - these materials are not suitable for use with solid fuel.

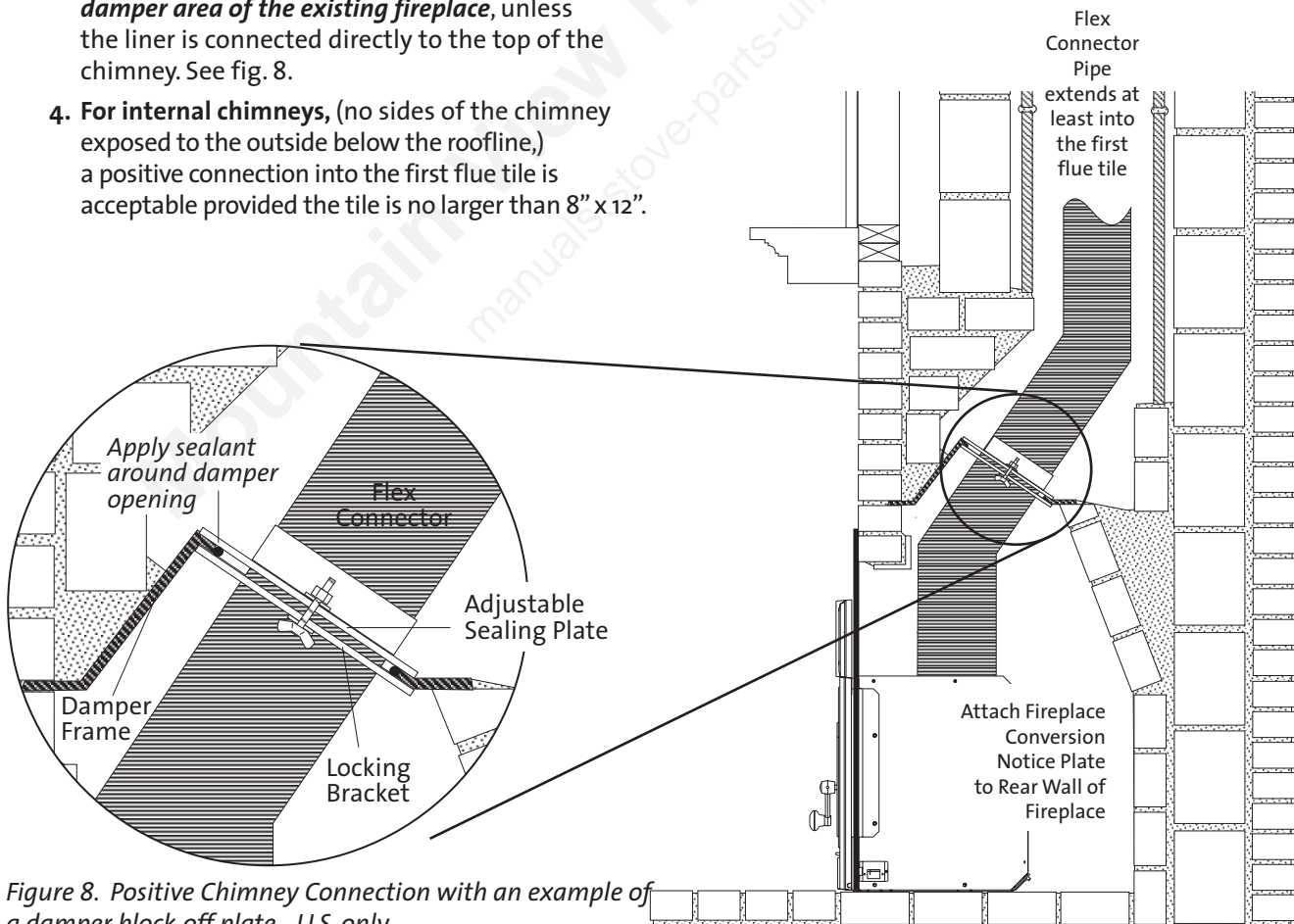

Figure 8. Positive Chimney Connection with an example of a damper block-off plate - U.S. only.

## Fireplace Chimney Preparation

1. Remove the existing damper and linkage components from the fireplace. Alternatively, you can wire the damper plate to lock it in the open position. Thoroughly clean the firebox and smokeshelf area with a wire brush.
2. If the fireplace has been modified to accommodate installation, use anchors or masonry nails to attach the metal Fireplace Conversion Notice Plate (PN 220508) to the back wall of the masonry fireplace firebox where it will be readily seen should the insert be removed.
3. If appropriate, install the damper sealing plate according to the manufacturer's instructions. The sealing plate may require trimming to accommodate your specific fireplace damper frame.

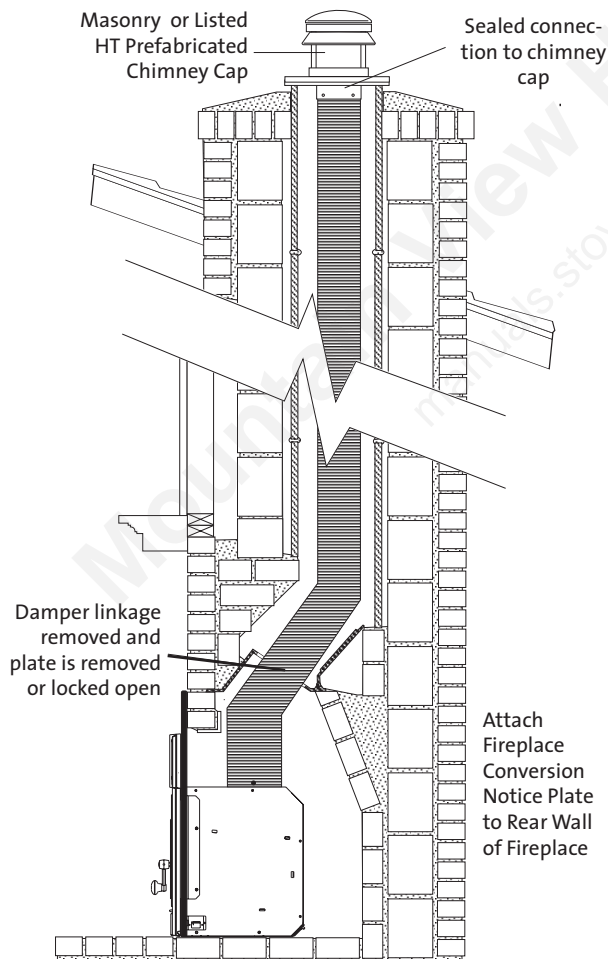

Figure 9. A fully-relined chimney is required in Canada and highly recommended in the U.S.

# Installing the Fireplace Insert

## Power Cord Orientation

If the optional Flex Conduit Kit 158002 will be installed, use the instructions included with that kit in conjunction with those below. See also Appendix, page 25.

1. Determine to which side the blower power cord will be routed. **DO NOT ROUTE THE POWER CORD ACROSS THE FRONT OF THE FIREPLACE.**
2. Insert the AC power receptacle lead through the appropriate inlet in the side of the firebox. See fig. 10. Remove the #8 x 5/8" phillips screw already in place and engage the receptacle bracket with the tab in the inlet opening. Reinstall the screw.
3. Route the AC power wire harness through the hole in the Inner Shroud and around the front of the blower. Plug the male quick-connector into the corresponding female connector on the blower wire harness, located between the two blowers. Loosen the Control Switchplate wing nut to swing the switch assembly out for better access to the female connector.

After connection, relocate the whole wire harness behind the blower and resecure the switchplate.

4. Plug the power cord into the receptacle, but do not plug it into the wall outlet until the installation is

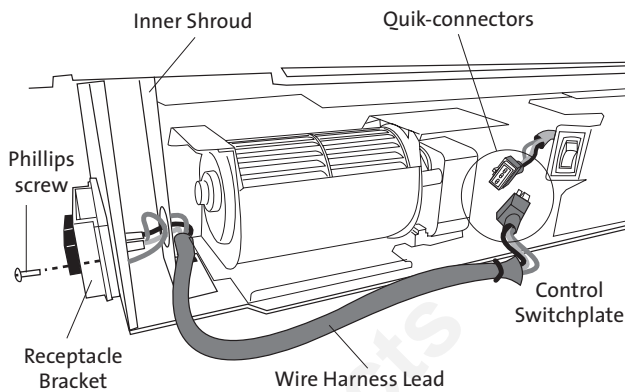

Figure 10. Routing the AC wire harness leads.

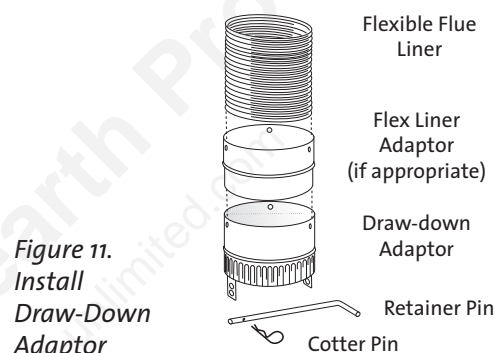

Figure 11. Install Draw-Down Adaptor

## Install the Draw-Down Adaptor

1. Insert the end of the chimney flue flex pipe as far as it will go into the non-crimped end of the adaptor or, if appropriate, the adaptor that may be supplied by the flex liner manufacturer. Orient the draw-down adaptor so that the retainer pin will be parallel with the front of the fireplace. This will ease locating the cotter pin hole. Fig. 11.
2. Drill holes through the flex pipe at the three pilot hole locations in the adaptor and secure with sheet metal screws.

## Install the Firebox

The cast iron baffles must be removed to secure the draw-down adaptor to the firebox. The Left Baffle has three bosses cast into the underside that engage with corresponding locator holes in the air tubes to lock each tube in correct position. Use a flashlight to locate the bosses by lifting up on the Left Baffle. See fig. 12.

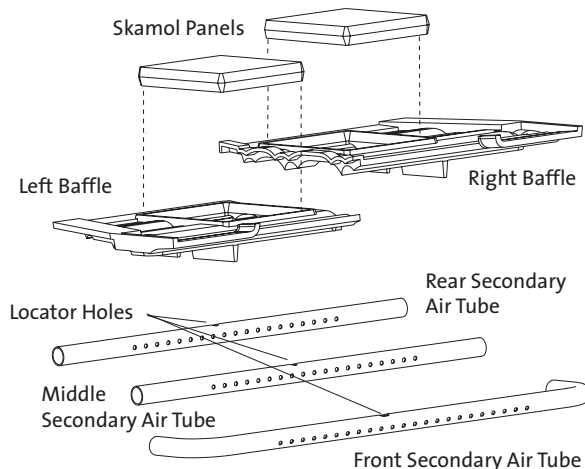

Figure 12. Remove Baffles and Front Secondary Air Tube.

5. Insert the retainer pin through the appropriate holes in the adaptor ears, and lock the retainer pin in place using the cotter pin.
6. Replace first the right baffle, then the left baffle, followed by the air tubes. **ADJUST THE AIR TUBES AS NECESSARY TO BE SURE EACH IS PROPERLY ENGAGED WITH THE ADJACENT LOCATOR BOSSES ON THE LEFT BAFFLE.**

Figure 13.

Surround Panel assembly  
viewed from backside.

Tools Required:

- 10 mm socket or wrench

**ENAMEL CAUTION NOTE:**  
The assembled surround  
is very heavy. Enamel  
surfaces may be easily  
damaged if parts strike  
against each other.  
Have assistance available  
to help carefully attach  
the surround to the  
firebox and avoid contact  
with the plinth assembly.

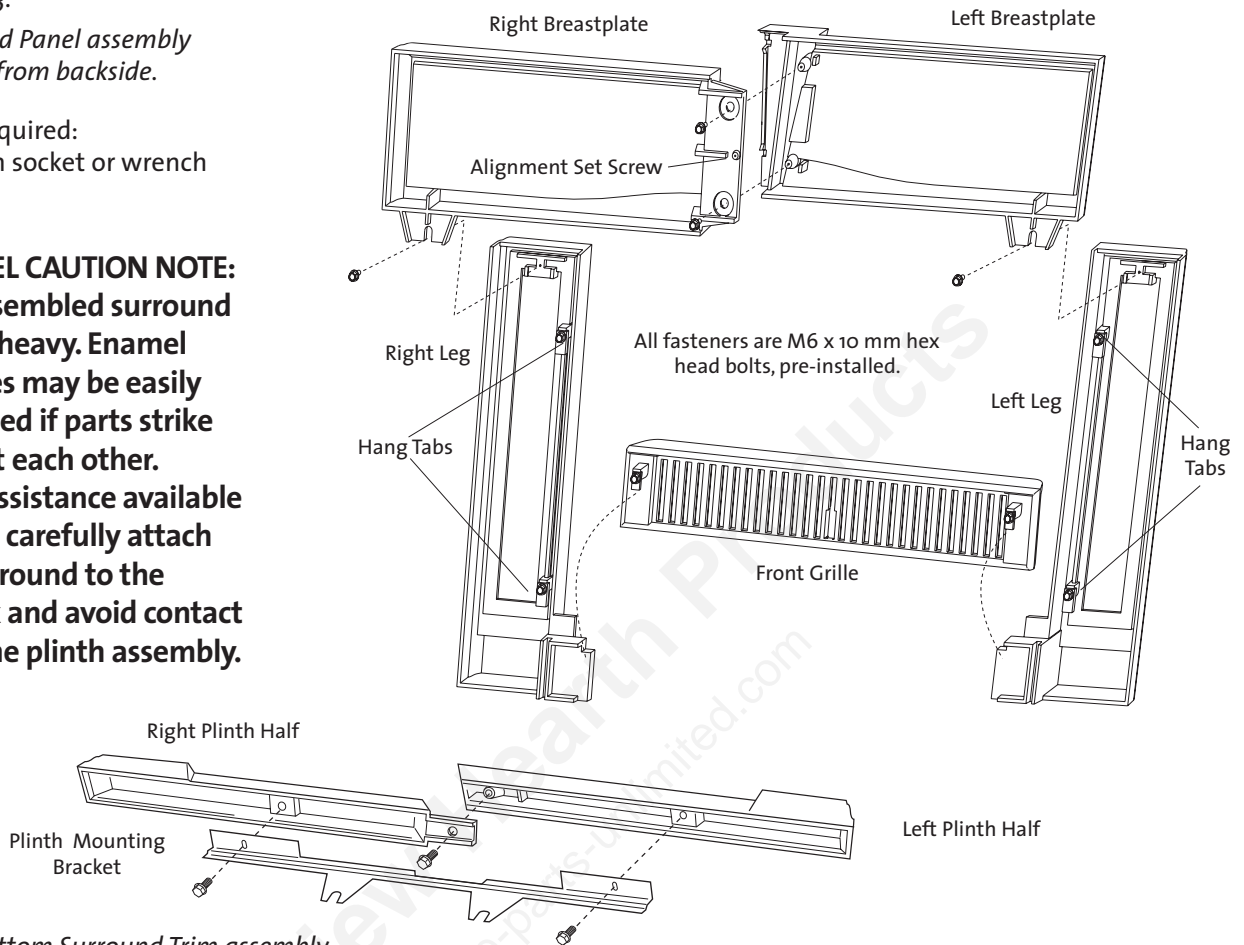

Figure 14. Bottom Surround Trim assembly.

## Surround Assembly

All fasteners have already been installed in the appropriate locations at the factory. You will need to remove them, attach the parts together as described below and reinstall the fasteners at those locations.

1. Layout the parts. Place the castings face down on a protective surface such as carpeting, blankets or a sheet of cardboard. See fig. 13.
2. Attach the Breastplates to each other. Use a 10 mm socket or wrench with two M6 x 10 hex head flange bolts. Adjust the set screw to obtain parallel alignment of the two plates.
3. Attach the Leg plates. The Legs must be oriented with the Hang Tabs on the inside edges as shown in fig. 13. Use the two remaining M6 x 12 hex head flange bolts to attach the Legs to the Breastplate assembly.
4. Attach the two Plinth half-panels together with the single M6 x 10 hex bolt. Attach the Plinth Mounting Bracket to the back of the Plinth assembly using the other two M6 x 10 bolts and washers. Orient the bracket as shown in fig. 14.
5. If appropriate, attach the Extended Surround Panel to the firebox. See illustration on page 6. With the painted side facing out, engage the hooked tabs on panel with the slots in the backside of the Surround Brackets on the firebox. Extend the blower power cord out beyond the front of surround panel.
6. Attach the Bottom Trim assembly to the two studs located in the firebox floor between the blowers using the M6 nuts already in place.
7. Attach the Surround assembly to the Firebox. Lift the entire assembly upright and position it in front of the insert firebox. The four Hang Tabs on the surround legs must engage with the adjacent cutouts in the two adjacent support brackets on the sides of the firebox opening. The surround will easily engage with these brackets if the firebox is slightly proud of the fireplace opening.
8. Check the alignment of the breastplates for “bowing” and adjust the set screw as necessary.
9. Push the entire unit into position so that the surround is flush against the fireplace face.

# Operation

Read the following section carefully before building a fire in your fireplace insert.

## Combustion Efficiency

The Jøtul C 550 has an EPA tested High Heating Value (HHV) efficiency rate of 71.48. There are, however, aspects of efficiency that you should be aware of in order to get the most from your stove.

Operation habits and fuel moisture can have a significant effect on efficiency. Poorly seasoned wood having a higher than optimum moisture content, can reduce the amount of energy transferred to the living area as a result of the energy expended to evaporate the excess fuel moisture in order for the wood to burn. Operational aspects, such as not building a robust kindling fire to readily ignite the larger fuel pieces, can result in an inefficient smouldering fire. Additionally, most modern wood heaters' optimum performance and efficiency are at the medium to medium-low burn rates.

The location of the stove can have a significant effect on heating efficiency, primarily in regards to distribution of the heat. For example, a wood heater centrally located in the residence in an open living area will likely provide better circulation of heat than will a stove located in a room adjacent to the larger living area.

## Minimize Carbon Monoxide Emissions

Testing the C 550 to CSA B414.1-10 measured carbon monoxide emissions at 141.62 g/hr. Most means of combustion produce some level of CO, including wood fires. Proper operation techniques, as outlined in this manual, will help ensure minimum emission output. Maintaining a well-established fire and avoiding operation that produces a smouldering, smoky fire, will greatly reduce CO levels.

It is highly recommended that a CO monitor (detector) be installed in the same room as the stove. The monitor, however, should be located as far away as possible from the stove to avoid alert soundings when adding fuel to the fire.

## Wood Fuel and Performance

The Jøtul C 550 is designed to burn natural wood only. Higher efficiencies and lower emissions generally result when burning air-dried, seasoned hardwoods, as opposed to softwoods, green or freshly cut hardwoods. Wood that has been air-dried for a period of 6 to 14 months will provide the cleanest, most efficient heat. Wood seasoned more than 2 years will burn too quickly to take advantage of the stove's low end efficiency strength.

A seasoned log will have check marks on the ends and be lighter than an unseasoned log which will show little or no check marks.

We recommend using a moisture meter to determine the moisture content of your wood. For purposes of home heating, your fuel should have a moisture content between 12 - 20%. Wood with higher moisture content will burn, however, very inefficiently. Most of its heat value will be lost to driving water out of the wood. Worse, that moisture can condense as creosote in the relatively cool chimney flue, increasing the potential for a chimney fire. Use of unseasoned wood defeats the purpose of any modern wood-burning stove.

### DO NOT BURN:

- Coal;
  - Garbage;
  - Synthetic fuel or logs;
  - Material containing rubber, including tires;
  - Material containing plastics;
  - Waste petroleum products, asphalt products, paints, paint thinners or solvents;
  - Materials containing asbestos;
  - Construction or demolition debris;
  - Railroad ties or pressure-treated wood;
  - Manure or animal remains;
  - Salt water driftwood or other previously salt-water saturated materials;
  - Unseasoned wood; or
  - Paper products, cardboard, plywood, or particle board.
- (The prohibition against burning these materials does not prohibit the use of fire starters made from paper, cardboard, saw dust, wax or similar substances for the purpose of starting a fire.)

The burning of any of these materials can result in the release of toxic fumes, or render the heater ineffective and cause smoke. Never use gasoline, gasoline-type lantern fuel, kerosene, charcoal lighter fluid, or similar liquids to start or "freshen-up" the fire. Always keep such liquids away from the heater at all times.

## C 550 CB Functionality

When used with dry wood and a well-drafting chimney system, modern non-catalytic wood stoves burn fuel efficiently by the precise control and delivery of primary and secondary air to the fire.

**Primary Air** is drawn into an inlet at the rear of the firebox and directed through a regulator shutter under the front door before entering the lower fire chamber. Additional primary air is directed to the top of the front door to act as an air wash which may prevent extreme soot build-up on the glass panel. The amount of primary air available to the fire determines the intensity of heat output and rate of fuel combustion; the greater the amount of air, the greater the heat output, the faster the wood burns. The primary air setting also determines the

effectiveness of the air wash over the glass; the more open the setting, the cleaner the glass will remain. Additional air is separately directed into the top of the fire chamber to support combustion of exhaust gasses before passing out of the stove. This unregulated **Secondary Air** enters through the inlet in the rear of the firebox and is heated as it passes over the back into a two-tiered manifold at the top of the firechamber. Volatile gases, released unburned from the fuel bed, rise to the baffle where they are turbulently mixed with the hot, fresh oxygen. Secondary combustion then occurs before the gasses pass into the heat exchange chamber.

## Air Control Settings

A single lever regulates the Primary Air flow that controls the intensity of the fire and consequent heat output and burn time. This lever is located within the slot on the upper right front of the fireplace insert.

When first starting or reviving the fire, the control lever should be set at the far right position to allow the maximum amount of air into the stove. See fig.15. After the fire is well-established, the lever should be set at position to moderate incoming air to maintain the desired long term heat output and/or burn time.

In general, the more air made available to the fuel will result in the hottest fire intensity and the fastest fuel consumption. Alternatively, the less air made available to the firebox will result in low heat output and slow fuel consumption.

## Break-in Period

The cast iron parts of your fireplace insert require a break-in process to allow them to gradually adjust to thermal expansion and contraction. This is accomplished by building a series of three or four fires, each somewhat hotter than the last. Allow the fireplace insert to cool completely before building the next fire.

Limit the first fire to just kindling and a couple of 1-2 inch logs and add progressively more and larger logs to subsequent fires, keeping the Air Control set to the fully open position.

It is normal for a new fireplace insert to emit odor and possibly smoke during the first few fires. This is characteristic of the burn-off of residues from the manufacturing process and the curing of painted surfaces. Open a window near the fireplace insert to provide plenty of fresh air to the room during this "seasoning" period.

**ALWAYS WEAR STOVE GLOVES WHILE TENDING THE FIRE.  
NEVER ALLOW THE FIRE TO REST DIRECTLY ON THE GLASS.  
KEEP THE LOGS SPACED AT LEAST ONE INCH FROM THE GLASS  
TO ALLOW FOR PROPER AIR FLOW WITHIN THE STOVE. AVOID  
STRIKING THE GLASS.**

## Blower Settings / Air Control

Use the following guide for best performance.

Burn Rate	Air Control Setting	Blower Speed
Low	5/32" Open	Low / On at 30 min.
Med. Low	3/16"-5/16" Open	Low / On at 30 min.
Med. High	5/16"-1/2" Open	Low / On at 30 min.
High	Max. Open	High / On

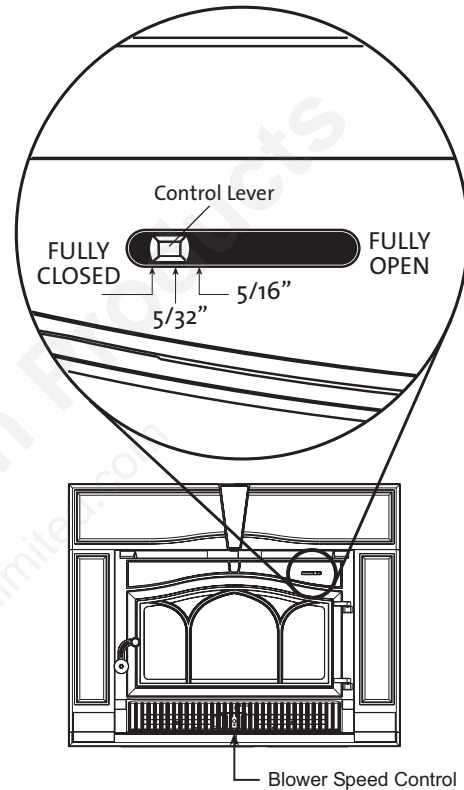

Figure 15. Air Control Setting

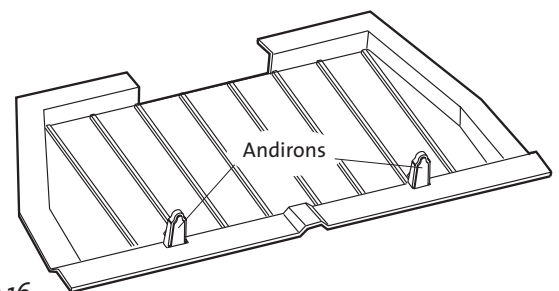

Figure 16. Fuel load area - keep logs behind the andirons.

**WARNING!**  
NEVER OVER-FIRE THE STOVE. IF ANY PART OF THE STOVE OR CHIMNEY GLOWS, YOU ARE OVER-FIRING. A HOUSE FIRE OR SERIOUS DAMAGE TO THE STOVE OR CHIMNEY COULD RESULT. IF THIS CONDITION OCCURS, IMMEDIATELY CLOSE THE AIR CONTROL.

## Starting and Maintaining a Fire

Burn only solid wood directly on the bottom grate of the stove. Do not elevate the fire in any way.

### Traditional Fire Building

1. With the primary air control lever in the full open position (*to the right*), start with several sheets of crumpled newspaper placed directly on the grate. On top of the newspaper, place several pieces of small dry kindling (approx. 1" in diameter) with two to three larger logs (approx. 3" to 5" in diameter) on top.
2. Light the fire and close the door, slowly building the fire by adding larger and larger logs. Be sure to follow the break-in procedure before creating a hot fire that might damage the stove.
3. Once the fire has become well established, adjust the primary air control lever as necessary to generate the desired heat output and burn time.

### Top-Down Fire Building - See fig. 17.

Many people find this method to be superior to the traditional method.

1. With the primary air control lever in the full open position (*to the right*), place two short 1/4-split logs on the firebox floor, perpendicular to the rear wall, about 6 inches apart.
2. Place kindling across the base logs.
3. Place one or two smaller logs on top of the kindling.
5. Place newspaper between the two bottom logs under the kindling. Light the news paper and close the door. Continue to add kindling and small logs as necessary to build the fire. Keep the air control fully open until the fire is well-established.

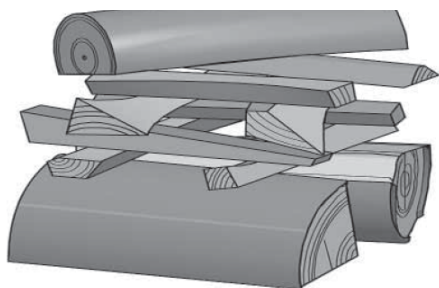

Figure 17. Top-down Firebuilding

## Adding Fuel to the Fire

When reloading the stove while a bed of hot embers still exists, follow this reloading procedure:

- Always wear stove gloves when tending to the fire.
- Push the Air Control Lever to the full open position (far right).
- **Always wait a few seconds before opening the door.** This allows the renewed air circulation to clear unburned gases from the firebox.
- Use a stove tool or poker to distribute the hot embers equally around the firebox.
- Load the fuel, usually with smaller logs first. **Keep logs behind the andirons.** See fig. 16.
- Close the doors and secure the latch.
- Wait 5 – 10 minutes for the fire to reestablish before adjusting the Air Control Lever for the desired heat output. If a thick bed of live coals is present, you may be able to add fuel and immediately set the air control without waiting for the fire to be reestablished.

Experiment with a variety of air control settings to determine the best one for your individual circumstances. Remember that fuel characteristics, chimney system condition, building design, and weather conditions all affect the performance of your fireplace insert. In time, you will discover how these elements combine and how you can work with them to achieve satisfactory performance.

**OPERATE THE INSERT ONLY WITH THE DOOR FULLY CLOSED. OPERATION WITH THE DOOR PARTIALLY OPEN MAY RESULT IN OVER-FIRING. IF THE DOOR IS LEFT PARTIALLY OPEN, GAS AND FLAME MAY BE DRAWN OUT OF THE STOVE CREATING SAFETY RISKS FROM BOTH FIRE AND SMOKE.**

---

## Creosote and Soot Formation and the Need for Removal

This appliance is designed to burn wood cleanly and efficiently when operated as described in this manual. However, when wood is burned slowly and at low temperatures, tar and other organic vapors are produced which condense on the relatively cooler chimney flue surfaces to form creosote. Failure to keep the chimney system free of creosote build up could result in a chimney fire.

The creosote that accumulates in the chimney is highly flammable and is the fuel of chimney fires. To prevent chimney fires, it is important to have the chimney flue and connector pipe cleaned and inspected at the beginning of the heating season and then inspected every other month during frequent use. Clean the chimney whenever creosote accumulation of 1/4" or more is evident. A qualified chimney sweep or other authorized service person can provide this service.

It is also important to remember that chimney size, temperature and height all affect draft which in turn affects the formation of creosote. An exterior chimney, whether masonry or prefabricated steel, will be exposed to cold outside temperatures, and consequently, will be more prone to creosote accumulation than an interior flue.

A chimney flue located within the home interior will benefit from the insulating characteristics of the building itself. Consequently, the flue system will be less conducive to condensation of unburned gases and minimal creosote accumulation will result.

As a general rule, try to avoid burning the insert at the lowest air control settings. Although a low setting will prolong burn time, it may also result in incomplete combustion. In reducing the fire intensity, draft is weakened and the chimney flue cools. This, together with the increase in unburned gases, leads to rapid creosote accumulation.

## Blower Operation

Access the blower control panel by lifting the cast iron lower grille up off the insert.

The dual blowers will enhance heat circulation around the firebox and out into the room. In the **Automatic** setting, the blowers are controlled by a heat activated switch (snapstat) that will only function when the speed control is ON. After the fire has been burning for a time, the snapstat will react to the heat and activate the blowers. Conversely, the blower will continue to operate until the snapstat cools as the fire wanes. The blowers will then shut off automatically.

The **Manual** setting overrides the snapstat functionality allowing blower operation regardless of temperatures.

For best performance, do not turn the switch on until after the fire is well-established.

If the blower is not needed, place the blower control switch in the OFF position.

See **Blower Maintenance**, page 19 for further information.

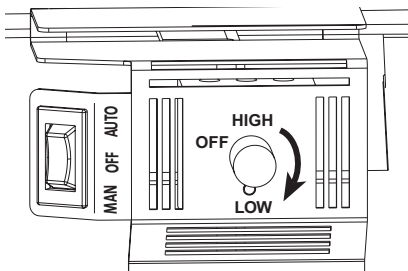
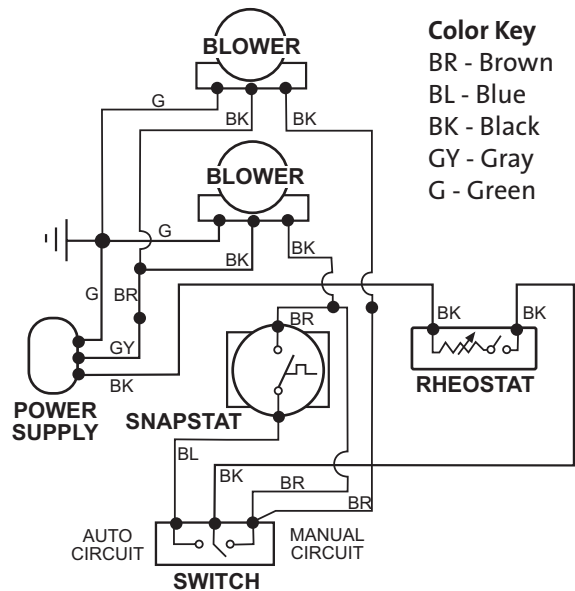

Figure 18. Blower and speed controls.

## WARNING !

- **THIS BLOWER MUST BE ELECTRICALLY GROUNDED IN ACCORDANCE WITH LOCAL CODES OR, IN THE ABSENCE OF LOCAL CODES, WITH THE CURRENT ANSI/NFPA 70, NATIONAL ELECTRICAL CODE OR CSA C22.1-CANADIAN ELECTRICAL CODE.**
- **THIS UNIT IS SUPPLIED WITH A THREE-PRONG (GROUNDING) PLUG FOR PROTECTION AGAINST SHOCK HAZARD AND SHOULD BE PLUGGED DIRECTLY INTO A PROPERLY GROUNDED THREE-PRONG RECEPTACLE. DO NOT CUT OR REMOVE THE GROUNDING PRONG FROM THE PLUG. DO NOT USE ANY POWER SUPPLY CORD OTHER THAN THAT SUPPLIED WITH THIS UNIT.**
- **ALWAYS DISCONNECT THE POWER SUPPLY WHEN PERFORMING ANY SERVICE ON THE FIREPLACE INSERT.**



NOTE: Terminals and switch markings are on opposite ends of the switch. See below.

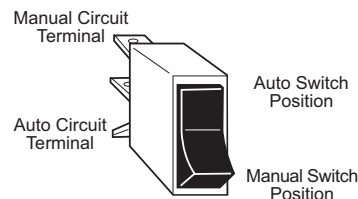

Figure 19. C 550 CB Wiring diagram.

# Maintenance

## Ash Removal

Always wear stove gloves when handling ashes.

Ash removal will be required periodically depending on frequency of use. Use a steel ash shovel and metal container with a tight-fitting lid. **NEVER USE A PAPER OR PLASTIC BAG AS AN ASH RECEPTACLE.**

The container of ashes should be placed on a non-combustible floor or on the ground, well away from all combustible materials, pending final disposal. If the ashes are disposed of by burial in soil or otherwise dispersed, **they should be kept in the closed container until all coals and cinders have thoroughly cooled.**

## Glass Care

### Cleaning

Occasionally it will be necessary to clean the carbon deposits and fly ash off of the glass. If deposits are allowed to remain on the glass for an extended period of time, the glass may become etched and cloudy.

Creosote deposits should burn off during the next hot fire.

1. The glass must be COMPLETELY COOL.
2. Only use a cleaner that is specifically designed for this purpose. **DO NOT USE ABRASIVE CLEANING AGENTS.** The use of abrasives will damage the glass, leaving a frosted surface. Crumpled newspaper is an especially good cleaning material.
3. Rinse and dry glass completely before lighting a fire.

## Glass Replacement

Always operate the doors slowly and cautiously to avoid cracking or breaking the glass. Never use the door to push wood into the firebox. If the glass becomes cracked or broken follow the replacement procedure below.

**NEVER OPERATE THE STOVE WITH A CRACKED OR BROKEN GLASS PANEL. Replace glass only with part # 156467 specifically designed for the Jøtul C 550 Rockland Fireplace insert. Do not use substitutes. Replacement glass can be ordered from your Jøtul dealer.**

1. Remove the door from the stove and place on a flat surface.
2. First loosen and then carefully remove all of the glass clips from the inside of the door. See fig. 20.
3. Remove all pieces of the glass panel and gasketing.
4. Remove all remaining debris from the glass area using a wire brush.
5. Apply a small bead of gasket/stove cement and the new gasket. Do not overlap the ends of the gasket rope.
6. **Orient the glass with the IR Coating label facing out.** Hold the glass at an angle to see the word "COATED" located at the lower edge. This side should face out when placed in the door. Center the new glass panel over the gasket and loosely reinstall the glass clips. Tighten the clips, alternating at opposite corners. Avoid applying uneven pressure on the glass..
7. It may be necessary to retighten the glass clips after the stove has burned and the gasketing has seated.

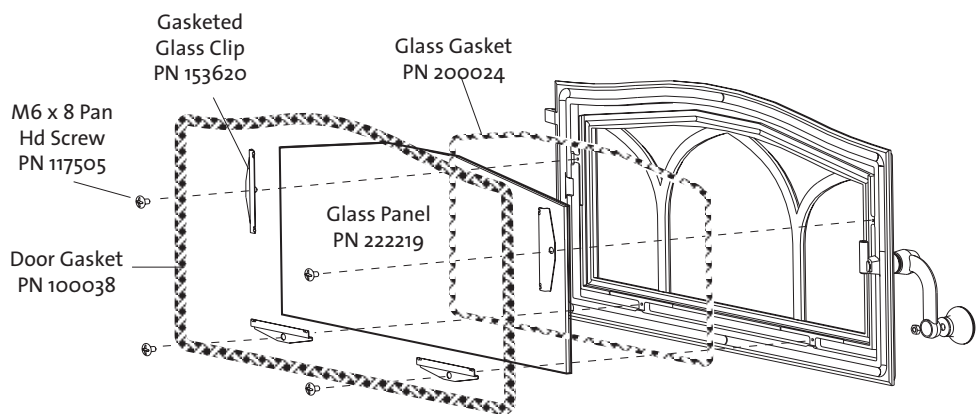

Figure 20.  
Replacing the  
door glass and  
gaskets.

# General Maintenance

## Chimney System

The Jøtul F 500 CB is designed to burn cleanly and efficiently when used according to the guidelines in this manual. In order to maintain proper performance, **you should inspect the chimney and chimney connector at the beginning of each heating season and then every other month during the heating season.** Clean the chimney whenever creosote and fly ash accumulation exceeds 1/4 inch in any part of the system.

Chimney brushes are available from your local Jøtul dealer or hardware supply store. Your dealer can also refer you to a reputable, professional chimney sweep who will have all the equipment to ensure a complete and proper job. Failure to keep the chimney system free of creosote and build-up could result in a serious chimney fire.

Regular maintenance will assure proper performance and prolong the life of your fireplace insert.. The following procedures do not take long and are generally inexpensive. When done consistently, they will help increase the life of your fireplace insert and assure satisfactory performance.

- Thoroughly clean the insert. Enamel surfaces should be cleaned with a moist cloth and polished dry..
- Empty firebox of all soot and ashes. Never use a household vacuum cleaner to remove ashes. Only a shop vacuum with a metal container is acceptable and only when you are certain the ashes are cold.
- Inspect the firebox using a utility light inside and out for cracks or leaks. Replace all cracked bricks and repair leaks with furnace cement.

## Removing the Insert for Cleaning

### U.S. Direct-connection Only:

1. Disconnect the blower power cord from its outlet.
2. Open the firebox door and pull the insert out enough to disengage the surround panel assemblies by lifting up off of the brackets.
3. Lift up the Left Cast Iron Baffle to disengage the locator boss from the Front Air Tube, and pull the air tube forward and out of the side manifolds.
4. Keeping the Rear Air Tube in place, push up on the Right Baffle and remove the Left Baffle.
5. Lift and remove the Right Baffle.
6. Slide the Rear Air Tube to one side to disengage it from the Side Manifolds.
7. Remove the retainer pin from the Draw-down Adaptor. Push up on the draw-down bar to disengage the adaptor from the insert
8. Pull the firebox and cabinet forward as a unit. The flue connector, liner, and chimney can now be inspected and cleaned.
9. See page 12 for reassembly procedures.

### Canada Installations (Full Reline):

The chimney liner can be swept directly into a bucket placed under the flue outlet, with removal of the two cast iron baffle plates.

1. Lift up the Left Cast Iron Baffle to disengage the locator boss from the Front Air Tube, and pull the air tube forward and out of the side manifolds.
2. Keeping the Rear Air Tube in place, push up on the Right Baffle and remove the Left Baffle.
3. Lift and remove the Right Baffle.
4. Slide the Rear Air Tube to one side to disengage it from the Side Manifolds.
5. Reassemble in the reverse order, being sure to engage the locator bosses on the Left Baffle with the corresponding holes in the Secondary Air Tubes.

## Gaskets

Check door and glass gaskets for seal integrity.

The gaskets should be soft enough to be somewhat resilient to the touch. Over time, gaskets will compress and harden. Replace worn-out or hardened gaskets with the appropriate size material available from your local Authorized Jøtul Dealer.

To check the seal of the front doors, close and latch the doors on a dollar bill and slowly try to pull the dollar bill free. The seal is too loose if the bill can be easily removed. Adjust the door latch and test again.

## Gasket Replacement

See the chart below for replacement gasket specifications. See also figs. 19-20 for locations.

1. Remove the old gasket material with a pliers and thoroughly clean the channel with a wire brush.
2. Lay out the new gasket around the channel to determine length. Trim the gasket to leave 1" excess.
3. Apply a small bead of gasket or furnace cement in the channel.
4. Lightly press the new gasket into the channel, being careful to avoid compressing or stretching it. Trim the gasket further as necessary to allow the tail end to slightly overlap the other end.
5. Wait ten minutes to allow the cement to set and then close and latch the doors. Reopen the doors and use a damp cloth to wipe away any excess cement that may be squeezed out from under the gasket.

### Replacement Gaskets

Glass		
LD .250 Fiberglass Rope	66"	200024
Door		
LD2 .350 Fiberglass Rope	70"	100038
Front		
LD2 .360 Fiberglass Rope	90.5"	117587
Air Manifold, Outer		
LD2 .250 SA Fiberglass Rope	30"	129644
Air Manifold, Inner		
.125 x 8 mm Flat SA	24"	127215

### Blower Maintenance

In order to ensure that the blower delivers many years of reliable performance, you should inspect it regularly and clean it of any household dust and debris that may have accumulated. This is particularly important if there are any pets in the home.

**Always disconnect the blower from its power source before cleaning.** Use a vacuum with soft brush attachment to clean the blower housing and compartment, as well as the area under the insert firebox.

*This page is intentionally blank.*

Mountain View Hearth Products  
manuals.stove-parts-unlimited.com

Use only genuine Jøtul replacement parts.  
Do not substitute parts from any other  
manufacturer. See your local Authorized  
Jøtul Dealer or contact us directly:

Jøtul North America  
55 Hutcherson Dr.  
Gorham, Maine 04038

### Jøtul C 550 CB Rockland Illustrated Parts Diagram

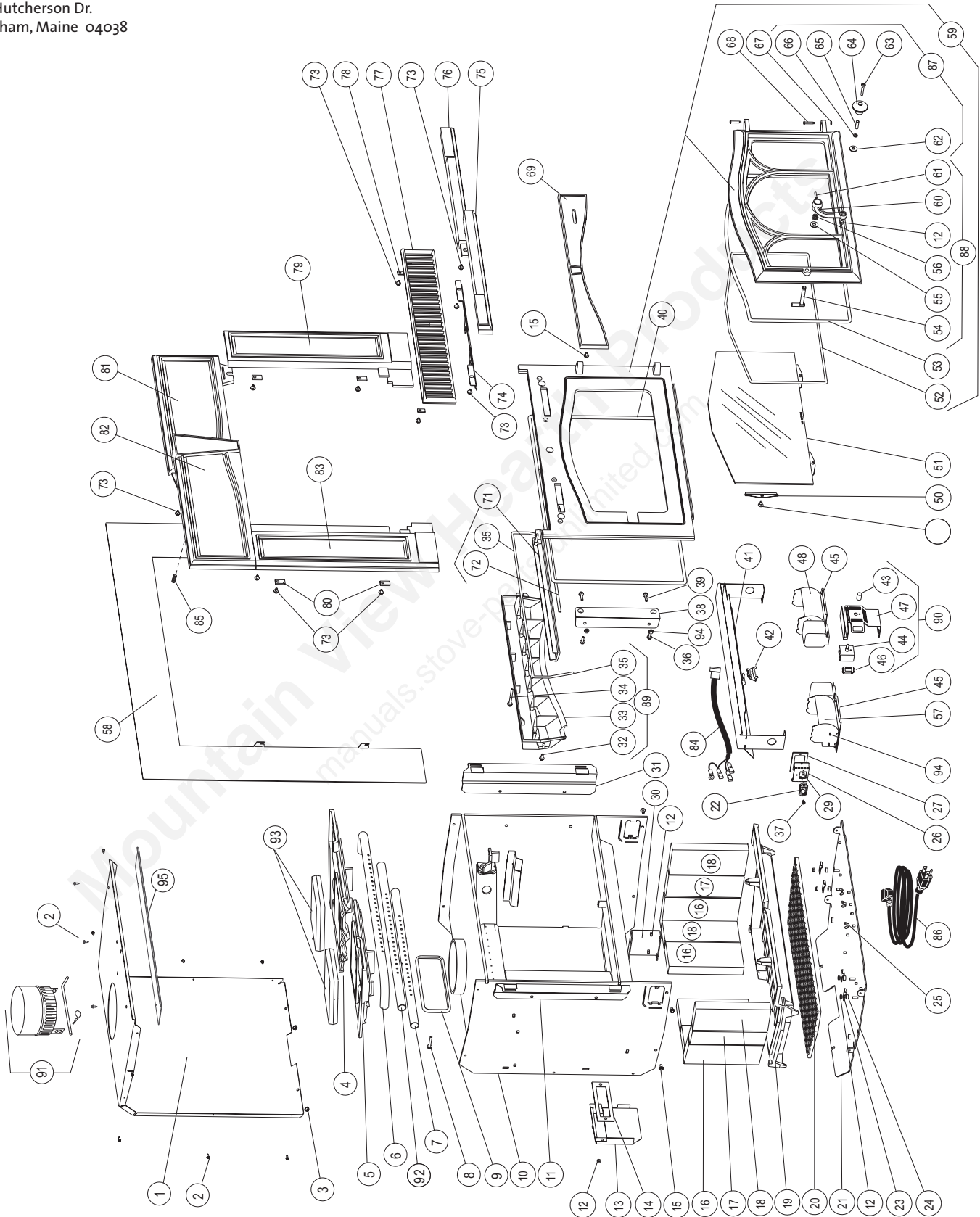

Figure 21.

## Jøtul C 550 CB Rockland Parts List

No.	Description	Part Number
1.	Rear Shroud	22202792
2.	Screw, #8 x 1/2" Hex SlT	117917
3.	Nut, M6 Flange	117968
4.	Right Baffle Plate	157045
5.	Left Baffle Plate	157044
6.	Secondary Air Tube, Front	223262
7.	Secondary Air Tube, Middle	222536
8.	Bolt, M6 x 40 SS Hex Hd	117997
9.	Brick Retainer, Cast Iron	104300
10.	Firebox Cavity	222535
11.	Surround Support, Left	222201
12.	Nut, M6 Hex	9930
13.	Secondary Air Channel	223279
14.	Blower Shield Assembly	221750
15.	Bolt, M6 x 12 Hex Hd Flange	117130
16.	Brick, 4.5 x 9.0 Refractory	129082
17.	Brick, 3.0 x 9.0 Refractory	220518
18.	Brick, 3.5 x 9.0 Refractory	222226
19.	Firebox Grate Plate	104312
20.	Insulating Panel, Grate	222433
21.	Shroud Assembly, Base	222028
22.	AC Power Receptacle	221790
23.	Clip, Attachment	222096
24.	Spacer, .250 x .500	117994
25.	Nut, M6 Wing	117975
26.	Receptacle Mounting Plate	222442
27.	Gasket, Receptacle Mounting Plate	129670
29.	Screw, M4 x 8 PH PH ZINC	117920
30.	Firebox Support	222223
31.	Surround Support, Right	222200
32.	Bolt, M6 x 16 Flange Head	99625
33.	Air Wash Manifold	104310
34.	Bolt, M6 x 60 Hex Head Serr. Flange	99101
35.	Gasket, LD .250 SA Fiberglass Rope- Outer, Air Manifold	129644
36.	Bolt, M8 x 20 Hex Head	117875
37.	Screw, #8 x .50 Hex Slot	117917
38.	Cast Attachment Plate	156792
39.	Bolt, M8 x 25 Flange Hex	117876
40.	Rope Gasket, Fiberglass - LD .360 x 6.5 ft. - Front Plate	100038
41.	Shroud, Blower	222221
42.	Snapstat, 110°F - 20°F	220755
43.	Knob, Rheostat	221788
44.	Rheostat, Solid State Variable Speed	221787
45.	Blower Base	222220
46.	Rocker Switch	220703
47.	Controls Bracket	222222
48.	Blower, 60 cfm Crossflow, RT DR.	156477
49.	Screw, M6 x 12 Pan Head	117505
50.	Glass Clip w/ gasket	153620
51.	Ceramic Glass panel	222219
52.	Rope Gasket, Fiberglass LD .250 x 5.5' - Glass Panel	200024
53.	Rope Gasket, Fiberglass LD .360 x 70" - Door	100038
54.	Door Latch Bolt	221720
55.	Washer, Door Handle	117587
56.	Compression Spring, Door Handle	126164
57.	Blower, 60 cfm Crossflow, LFT DR	156476
58.	Extended Surround (optional) / Matte Black Paint	156432
59.	Front Ass'y w/ Door - Matte Black, Lattice	156482
	Front Ass'y w/ Door - Matte Black, Clean Face	157399
	Front Ass'y w/ Door - Brown Majolica Enamel, Lattice	157317
	Front Ass'y w/ Door - Brown Majolica Enamel, Clean Face	157664

No.	Description	Part Number
60.	Cast Iron Door Handle	103712
61.	Roll Pin, 5 mm x 24 mm	117733
62.	Washer, Insulating	124385
63.	Bolt, M6 x 40 PHP	117796
64.	Door Knob, Wooden	126244
65.	Sleeve, Door Handle	126229
66.	Washer	110904
67.	Washer, M6, 12 x .05	117588
68.	Hinge Pin	127075
69.	Air Cover Plate - Matte Black Paint	156496
	Air Cover Plate - Blue Black Enamel	156486
	Air Cover Plate - Brown Majolica Enamel	157300
71.	Air Slider, Matte Black Paint	156712
	Air Slider, Nickel Plated	156714
72.	Gasket, .125 x 8 mm Flat SA - Inner, Air Manifold	127215
73.	Bolt, M6 x 10 Hex Hd Flange	99627
74.	Bracket, Bottom Trim	222427
75.	Trim, Bottom Left - Matte Black Paint	156706
	Trim, Bottom Left - Blue Black Enamel	156491
	Trim, Bottom Left - Brown Majolica Enamel	157306
76.	Trim, Bottom Right - Matte Black Paint	156708
	Trim, Bottom Right - Blue Black Enamel	156492
	Trim, Bottom Right - Brown Majolica Enamel	157307
77.	Control Door - Matte Black Paint, inc. hardware	156479
	Control Door - Blue Black Enamel	156480
	Control Door - Brown Majolica Enamel	157305
78.	Hang Tab	129680
79.	Surround Leg, Right - Matte Black Paint	156704
	Surround Leg, Right - Blue Black Enamel	156490
	Surround Leg, Right - Brown Majolica Enamel	157304
80.	Hang Tab	224144
81.	Surround Panel, Breastplate, Right - Matte Black	156700
	Surround Panel, Breastplate, Right - Blue Black	156488
	Surround Panel, Breastplate, Right - Brown Majolica	157302
82.	Surround Panel, Breastplate, Left - Matte Black	156498
	Surround Panel, Breastplate, Left - Blue Black	156487
	Surround Panel, Breastplate, Left - Brown Majolica	157301
83.	Surround Leg, Left - Matte Black Paint	156702
	Surround Leg, Left - Blue Black Enamel	156489
	Surround Leg, Left - Brown Majolica Enamel	157303
84.	AC Harness w/ Receptacle, Replacement	156485
85.	Set Screw, M6 x 10 mm - Surround adjustment	04-117720
86.	Blower Power Cord, HT	221789
87.	Wooden Knob Replacement Kit	151991
88.	Handle Asy, Complete / Matte Black Paint	156320
	Handle Asy, Complete / Nickel Plated	156021
89.	Airwash Manifold, inc. gasket / Matte Black Paint	156710
90.	Blower Control Module, inc. #43, 44, 46, 47	156715
91.	Draw-down Adaptor	156073
92.	Rear Secondary Air Tube	223263
93.	Skamol Panel	222731
94.	Nut, M8, Flange	11788195
95.	Top Shroud Extension *	22557592
96.	C 550 CB Clearance Reduction Kit	157705
	Replacement Door, Special Edition - Matte Black	157399
	Mantel Heat Shield	156448

\* **Not included on stoves having serial numbers 1001 through 11902. The C 550 CB Clearance Reduction Kit 157705 is approved for use to update those units for installation at the clearances published on page 9 of this manual. Serial numbers are located on labels on the shipping label, blower compartment floor, and firebox shroud.**

# Appendix A

## Alternate Hearth Protection

All hearth protection materials must be noncombustible; i.e. metal, brick, stone, or mineral fiber boards. Any combustible material may not be used.

Follow the procedures below to determine if a proposed alternate floor material meets requirements listed in this manual.

- R-value = thermal resistance
- k-value = thermal conductivity
- C-value = thermal conductance

1. Convert the specification to R-value:
  - a. If r-value is given, no conversion is needed.
  - b. If k-value is given with a required thickness (T) in inches:  $R = 1/k \times T$ .
  - c. If C-value is given:  $R = 1/C$ .
2. Determine the R-value of the proposed alternate floor protector.
  - a. Use the formula in Step 1 to convert values not expressed as "R".
  - b. For multiple layers, add R-values of each layer to determine overall R-value.
  - c. If the overall R-value of the system is greater than the R-value of the specified floor protector, the alternate is acceptable.

### Example:

The specified floor protector should be 3/4" thick material with a k-factor of 0.84. The proposed alternate is 4" brick with a C-factor of 1.25 over 1/8" mineral board with a k-factor of 0.29.

Step 1. Use the formula above to convert specifications to R-value.  $R = 1 \times T = 1/.84 \times .75 = .893$

Step 2. Calculate R of proposed system.

- 4" brick of C = 1.25, therefore
- R brick =  $1/C = 1/1.25 = 0.80$
- 1/8" mineral board of k = 0.29, therefore
- R mineral board =  $1/.29 \times 0.125 = 0.431$

Total R = R brick + R mineral board =  $0.8 + 0.431 = 1.231$

Step 3. Compare proposed system R = 1.231 to specified R of 0.893. Since R is greater than required, the system is acceptable.

### Definitions:

Thermal conductance =

$$C = \frac{\text{Btu}}{(\text{hr})(\text{ft}^2)(\text{F})} = \frac{\text{W}}{(\text{m}^2)(\text{K})}$$

Thermal conductivity =

$$k = \frac{\text{Btu}}{(\text{hr})(\text{ft}^2)(\text{F})} = \frac{\text{W}}{(\text{m}^2)(\text{K})} = \frac{(\text{Btu})}{(\text{hr})(\text{ft})(\text{F})}$$

Thermal resistance =

$$R = \frac{(\text{ft}^2)(\text{hr})(\text{F})}{\text{Btu}} = \frac{(\text{m}^2)(\text{K})}{\text{W}}$$

## Leg Leveler Installation

Two leg leveler bolts are contained within the Miscellaneous Kit included inside the firebox. The bolts are intended to help level and plumb the firebox if irregularities exist between the front and rear of the fireplace hearth.

Examine the hearth floor to determine any difference in height between the front and rear or side to side. Slide the firebox into the fireplace to confirm whether or not the leveler bolts will be necessary.

If appropriate, install the bolts through the tapped holes located in the firebox floor approximately 6" from the rear of the firebox. Adjust as necessary to achieve correct lateral level and vertical plumb.

Figure 22. Surround assembly is out of plumb because firebox is not level.

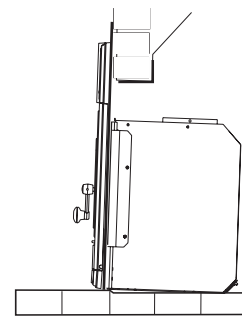
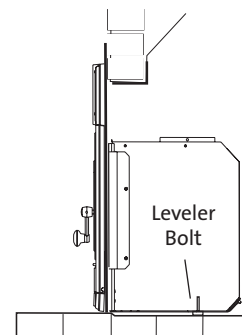

Figure 23. Install leveler bolts to level the firebox and achieve correct surround assembly alignment.



## Door Knob Installation

The Door Knob components are included in a separate bag contained within the Miscellaneous Kit included with the firebox. Install the parts in the order shown in fig. 22. Phillips screwdriver required.

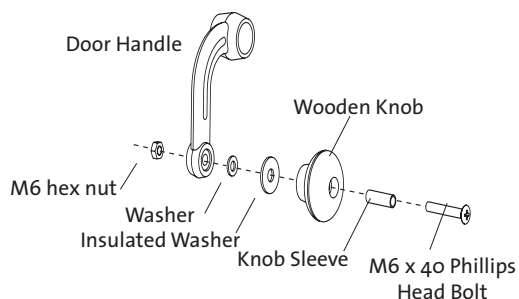

Figure 24. Door knob assembly.

## Blower Flex Conduit Kit 158002

### Kit Contents:

- Flex Conduit Wire Assembly
- Harness Bracket, C350 - small
- Harness Bracket, C550 - large
- Firebox Riser Bar

### Tools Required:

- 1.4" socket driver
- phillips screwdriver

### READ THESE INSTRUCTIONS BEFORE BEGINNING THE INSTALLATION.

The blowers must be electrically grounded in accordance with local codes or, in the absence of local codes, with the current ANSI/NFPA 70, National Electrical Code or CSA C22.1-Canadian Electrical Code.

### Procedure

#### 1. Determine the routing for the power line.

The **flex conduit** may be connected to the blower assembly at either side of the insert firebox. The conduit may be routed through the masonry fireplace to 110vac current at any conveniently-located junction box. It may also be routed under the firebox to an ash dump or other suitable access point using either the short Riser Frame from this kit, or the larger Riser Bar included with the C 350 firebox. Position the riser as shown in fig. 25.

Before installing the firebox, route the conduit to the power source junction box and seal any seams or holes to prevent air infiltration into the fireplace.

Use anchors or masonry nails to attach the metal Fireplace Conversion Notice Plate (PN 220508 included with the insert) to the masonry firebox where it will be readily seen should the insert be removed.

2. See Fig. 26. Using the Blower Wire Harness shipped in the insert Miscellaneous Hardware Kit, disconnect the blower wiring leads, (A) from that harness receptacle bracket. Keep the Ground wire, (B) Kepnut for reuse.
3. Use the harness Lock Ring, (C) to attach the Flex Conduit Elbow, (D) to the appropriate-size Harness Bracket, (E) for either the C 350 or C 550 the insert model.
4. Connect the Blower Wire Harness leads to the appropriate color Conduit leads. Connect the blower Ground wire to the receptacle pemstud using the original Kepnut (B).
5. Use the pre-installed phillips screw, (F) to attach the Harness Bracket to the firebox.
6. Complete the blower installation procedure as described

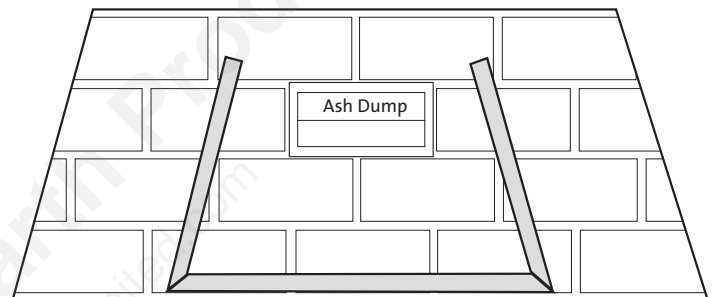
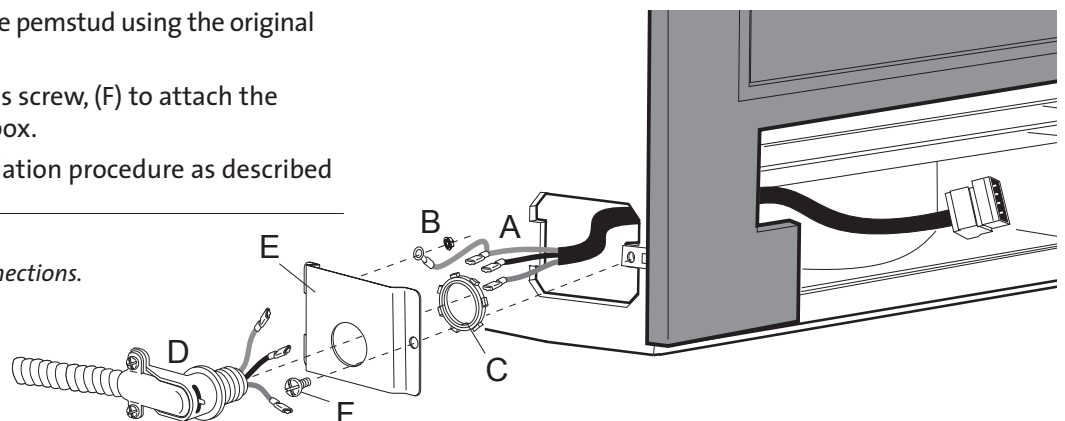

Fig. 25. Riser Frame placement within fireplace.

in the fireplace insert manual.

7. Install the Cover plate from the Hardware Kit over the unused receptacle opening using the pre-installed screw at that location.
8. **BEFORE FINAL FIREBOX POSITIONING:**
  - Pull any excess conduit out of the fireplace through the wall or ash dump, or coil it to prevent contact with the sides of the fireplace insert firebox.
  - Test the blowers for functionality. See the installation manual for operation instructions.

Fig. 26. Blower wire harness connections.



# Jøtul C 550 CB Rockland Limited Warranty

Effective January 1, 2013.

This warranty policy applies to wood-burning products identified by Jøtul and Scan trade names, as set forth below.

## **A. LIMITED LIFETIME WARRANTY, parts only:**

Jøtul North America Inc. (JØTUL) warrants, to the original retail purchaser, that those baffle and air manifold components of the Jøtul or Scan Stove or Fireplace Insert specified above will be free of defects in material and workmanship for the life of the product. This warranty is subject to the terms, exclusions and limitations set forth below.

## **B. LIMITED FIVE YEAR WARRANTY - Cast Iron and Steel Components:**

JØTUL warrants, to the original retail purchaser, that those components of the Jøtul or Scan Stove or Fireplace Insert specified above will be free of defects in material and workmanship for a period of five (5) years from the date of purchase. This warranty is subject to the terms, exclusions and limitations set forth below.

## **C. LIMITED TWO YEAR WARRANTY - Enamel Finish:**

JØTUL warrants, to the original retail purchaser, the enamel finish on cast iron components of the Jøtul Stove or Fireplace Insert specified above against peeling or fading for a period of two (2) years from the date of purchase. This warranty is subject to the terms, exclusions and limitations set forth below.

## **D. LIMITED ONE YEAR WARRANTY - Electrical Components (blowers, thermostatic switches):**

JØTUL warrants, to the original retail purchaser, that those components of the Jøtul or Scan Stove or Fireplace Insert specified above will be free of defects in material and workmanship for a period of one (1) year from the date of purchase. This warranty is subject to the terms, exclusions, and limitations set forth below:

JØTUL will repair or replace, at its option, any of the above components determined by JØTUL to be covered by this warranty. You must, at your own expense, arrange to deliver or ship the component to an authorized Jøtul or Scan dealer and arrange for pickup or delivery of the component after repairs have been made. If, upon inspection, JØTUL determines that the component is covered by this warranty, the repair or replacement will be made as set forth above. This warranty is not transferable and is extended only to, and is solely for the benefit of, the original retail purchaser of the Jøtul or Scan Stove or Fireplace Insert. This paragraph sets forth the sole remedy available under this warranty in the event of any defect in the Jøtul Scan Stove or Fireplace Insert. The warranty period for any replaced component will be the remaining unexpired portion of the warranty period for the original component. Please retain your dated sales receipt in your records as proof of purchase.

## **EXCLUSIONS AND LIMITATIONS**

NOTICE: This warranty is void if installation or service is performed by someone other than an authorized installer or service agency, or if installation is not in conformance with the installation and operating instructions contained in this owner's manual or local and/or national fire and building regulations. A listing of local authorized installers, service agencies and gas suppliers can be obtained from the National Fireplace Institute at <http://www.nficertified.org/>.

This warranty does not cover the following:

- 1) Repair or replacement of parts that are subject to normal wear and tear during the warranty period or to parts that may require replacement in connection with normal maintenance. These parts include paint, gaskets, burn plates, ceramic insulation blankets, skamol baffles and panels, firebricks, fire grates, or glass (Ceramic glass is warranted against thermal breakage only).
- 2) Damage due to incorrect installations not in conformance with the installation instructions contained in this owner's manual or local and/or national fire and building regulations.
- 3) Damage, including damage to enamel surfaces, caused by improper operation, over-firing, and/or misuse. Improper operation, such as burning the stove with the ash door open, can damage the stove. Over-firing occurs when any part of the stove glows red. Over-firing can also be identified by warped plates, rust-colored cast iron, paint pigment that has turned dusty white, or bubbling, cracking and discoloration of the enamel finish. Misuse includes, without limitation, use that is not in conformance with the operating instructions contained in this owner's manual.
- 4) Damage to enamel finish including chipping, mechanical or chemical abrasion, crazing, staining, or rust caused by high humidity or salt air environments.
- 5) Damage from or repair of rust. Use of a stove-top steamer can cause rust.
- 6) Damage due to service performed by an installer or service agency, unless otherwise agreed to in writing by JØTUL.
- 7) Damage caused by unauthorized modification, use or repair.
- 8) Costs incurred by travel time and/or loss of service.
- 9) Labor or other costs associated with the repair of components beyond the warranty period.
- 10) Damage incurred while the Jøtul or Scan Stove or Fireplace is in transit.

IN NO EVENT SHALL JØTUL, ITS PARENT COMPANY, SHAREHOLDERS, AFFILIATES, OFFICERS, EMPLOYEES, AGENTS OR REPRESENTATIVES BE LIABLE OR RESPONSIBLE TO YOU FOR ANY SPECIAL, INDIRECT, INCIDENTAL, CONSEQUENTIAL, PUNITIVE OR OTHER SIMILAR DAMAGES, INCLUDING, BUT NOT LIMITED TO, LOST PROFITS, LOST SALES, INJURY TO PERSON OR PROPERTY, OR DAMAGES TO A STRUCTURE OR ITS CONTENTS, ARISING UNDER ANY THEORY OF LAW WHATSOEVER. ALL IMPLIED WARRANTIES, INCLUDING THE IMPLIED WARRANTIES OF MERCHANTABILITY AND FITNESS FOR A PARTICULAR PURPOSE, OR OTHERWISE, ARE LIMITED IN DURATION TO THE LENGTH OF THIS WRITTEN WARRANTY. EXCEPT AS EXPRESSLY SET FORTH HEREIN, JØTUL MAKES NO ORAL, WRITTEN OR OTHER WARRANTY WITH RESPECT TO JØTUL OR SCAN STOVES OR FIREPLACES.

Some states do not allow the exclusion or limitation of incidental or consequential damages, or limitations on the length of implied warranties. Therefore, the above exclusions or limitations may not apply to you. This warranty gives you specific legal rights, and you may have other rights, which vary from state to state.

JØTUL reserves the right to discontinue, modify or change the materials used to produce the Jøtul or Scan Stove or Fireplace Insert. JØTUL shall have the right to replace any defective component with substitute components determined by JØTUL to be of substantially equal quality and price.

The dollar value of JØTUL's liability for breach of this warranty shall be limited exclusively to the cost of furnishing a replacement component. JØTUL may at its discretion discharge all obligations by refunding the wholesale price of any defective part or appliance. JØTUL shall in no event be liable for any special, indirect or consequential damage of any nature which is in excess of the original wholesale purchase price of the product. JØTUL shall not in any event be liable for the cost of labor expended by others in connection with any defective component. Any costs or expenses beyond those expressly assumed by JØTUL under the terms of this warranty shall be the sole responsibility of the owner(s) of the Jøtul Stove or Fireplace.

No dealer, distributor, or other person is authorized to modify, augment, or extend this limited warranty on behalf of JØTUL. NO MODIFICATION OR CHANGE TO THIS WARRANTY WILL BE EFFECTIVE UNLESS IT IS MADE IN A WRITTEN DOCUMENT MANUALLY SIGNED BY AN AUTHORIZED OFFICER OF JØTUL.

An authorized installer may have been provided with certain information related particularly to the Jøtul or Scan Stove or Fireplace; however, no authorized installer or other person who may service the appliance is an agent of JØTUL. No inference should be made that JØTUL has tested, certified, or otherwise pronounced any person as qualified to install or service the appliance. JØTUL shall not be liable or otherwise responsible for any error or omission by a person installing or servicing a Jøtul or Scan Stove or Fireplace Insert.

If you believe your Jøtul or Scan Stove or Fireplace Insert is defective, you should contact your nearest authorized Jøtul dealer, who will process a warranty claim. IN ORDER TO QUALIFY FOR WARRANTY COVERAGE, JØTUL MUST RECEIVE NOTICE OF A POSSIBLE DEFECT WITHIN SIXTY (60) DAYS OF THE DATE THE DEFECT IS FIRST DISCOVERED, OR REASONABLY COULD HAVE BEEN DISCOVERED.

This warranty is given by Jøtul North America, Inc.,  
55 Hutcherson Drive, Gorham, Maine 04038 USA

139656\_R09  
August 2017

Mountain View Hearth Products  
manuals.stove-parts-unlimited.com

**Jøtul North America, Inc.**

55 Hutcherson Dr.  
Gorham, Maine 04038  
USA

**Jøtul AS**

P.O. Box 1411  
N-1602 Fredrikstad,  
Norway

[www.jotul.us](http://www.jotul.us)

