



HEARTH PRODUCTS

# INSTALLATION AND OPERATION INSTRUCTIONS

## Solana™

EPA Low-Mass Wood-burning Fireplace Phase 2 Qualified

43" Wood-Burning Fireplaces

P/N 506023-07 REV. B 06/2010

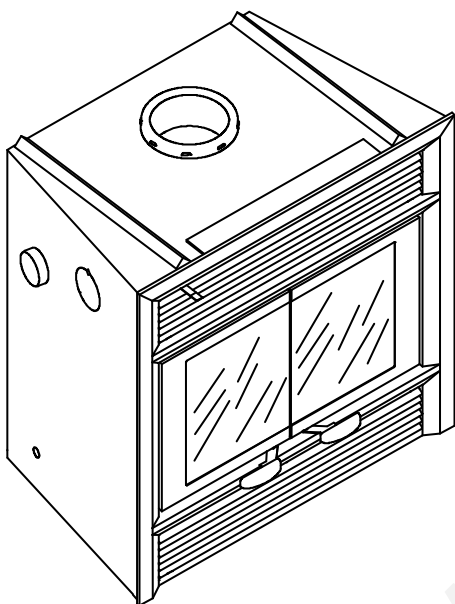

### MODELS

SOLANA-BK  
SOLANA-BN



This installation manual will enable you to obtain a safe, efficient and dependable installation of your fireplace system. Please read and understand these instructions before beginning your installation.

Do not alter or modify the fireplace or its components under any circumstances. Any modification or alteration of the fireplace system, including but not limited to the fireplace, chimney components and accessories, may void the warranty, listings and approvals of this system and could result in an unsafe and potentially dangerous installation.

Lennox Hearth Products wood-burning fireplaces are designed for use as a supplemental heater. They are not intended for continuous use as a primary heat source.

SAVE THESE INSTRUCTIONS FOR FUTURE REFERENCE

	<b>⚠ WARNINGS</b>
	<ul style="list-style-type: none"> <li>Hot! Do not touch! The glass and surfaces of this appliance will be hot during operation and will retain heat for a while after shutting off the appliance. Severe burns may result.</li> <li>Carefully supervise children in the same room as appliance.</li> </ul>

<b>⚠ WARNINGS</b>
<ul style="list-style-type: none"> <li>The fireplace cannot be operated without doors or firescreens. Consult your dealer to select the correct replacement door(s) or firescreen(s).</li> <li>Important! To assure proper alignment of glass doors: Install this fireplace in a square and plumb condition, using shims as necessary at sides and/or bottom.</li> <li>Install the fireplace only as described in these instructions.</li> </ul>

	<p>Listed to standards: ULC-S610 &amp; UL-127 ASTM 2558 Report No. 192-5237</p>
--	---

	<p>We recommend that our woodburning hearth products be installed and serviced by professionals who are certified in the U.S. by the National Fireplace Institute® (NFI) as NFI Woodburning Specialists or who are certified in Canada by Wood Energy Technical Training (WETT).</p>

**IMPORTANT! GENERAL SAFETY PRECAUTIONS. READ AND UNDERSTAND THESE SAFETY RULES BEFORE YOUR FIRST FIRE.**

**! WARNING**

The Solana™ fireplace must be installed with an outside air kit intake, which is included with the fireplace.

**! WARNING**

THE FIREPLACE MUST BE OPERATED WITH THE DOORS FULLY OPENED OR DOORS FULLY CLOSED. IF THE DOORS ARE LEFT PARTLY OPENED, GAS AND FLAME MAY BE DRAWN OUT OF THE FIREPLACE OPENING, CREATING RISKS OF BOTH FIRE AND SMOKE. IF THE UNIT IS OPERATED WITH THE DOORS FULLY OPENED, THE FIRE SCREEN MUST BE USED.

**! WARNING**

NEVER use gasoline, gasoline-type lantern fuel, kerosene, charcoal lighter fluid, naphtha, engine oil or similar liquids to start or “freshen up” a fire in this fireplace. Keep any flammable liquids a safe distance from the fireplace at all times.

**! WARNING**

THIS FIREPLACE HAS NOT BEEN TESTED WITH AN UNVENTED GAS OR A FIREPLACE INSERT. TO REDUCE RISK OF FIRE OR INJURY, DO NOT INSTALL AN UNVENTED GAS LOG SET OR FIREPLACE INSERT OR OTHER PRODUCTS NOT SPECIFIED FOR USE WITH THIS FIREPLACE.

**! WARNING**

Never leave children unattended when there is a fire burning in the fireplace.

**! CAUTION**

Use care when selecting window treatments for windows located near the fireplace. Avoid using combustible flowing window treatments such as curtains on nearby windows that are of sufficient length to be blown in front of an open flame when the window is opened.

Keep any combustible furniture, materials or decorative pillows at least 48" (1219 mm) from the front fireplace opening.

**! WARNING**

Never leave your fireplace unattended while it is burning.

**! IMPORTANT**

When burning wood, use SOLID NATURAL DRY WELL-SEASONED WOOD ONLY. Hardwoods are recommended (soft woods tend to burn very quickly).

- DO NOT burn treated wood, charcoal, coal, trash, cardboard, driftwood, woods dipped in tar, Christmas tree greens, pitch, pine tar, creosote, chemical chimney cleaners, flame colorants, polystyrene packaging, wood products with synthetic binders (i.e. plywood). Plywood, lumber and other misc. materials can produce abnormally high temperatures, sputtering and smoking fires and may contain hazardous chemicals to treat insects and fungus.

- Burning unapproved fuels can produce excessive temperatures, beyond the design capabilities of the fireplace and may produce excess sparks or may contain hazardous chemicals. Burning unapproved fuels can result in a chimney fire, a house fire, personal injury, death or loss of property.

**! WARNING**

To avoid the risk of damaging fireplace materials and increasing the risk of fire, do not use the fireplace to cook or warm food.

**! WARNING**

Be careful adding wood fuel to the fire or handling fireplace tools such as shovels, tongs or pokers.

**! WARNING**

Never modify or alter your fireplace system in any way. To do so may create a potential fire hazard and void the limited warranty, listings and approvals of this system.

**! WARNING**

The bottom refractory can be cracked by excessive abuse such as tossing heavy logs onto the grate or gouging with fireplace tools. Exercise caution when adding wood to your fireplace.

**! WARNING**

Neither the manufacturer nor the seller warrants “smoke free” operation nor are we responsible for inadequate system draft caused by mechanical systems, general construction conditions, inadequate chimney heights, adverse wind conditions and/or unusual environmental factors or conditions beyond our control.

**! WARNING**

Always ensure that the air inlet to the fireplace is free from debris and any other obstructions that can block the entrance of air.

## CONGRATULATIONS!

When you purchased your new fireplace, you joined the ranks of thousands of individuals whose answer to their home heating needs reflects their concern for aesthetics, efficiency and our environment. We extend our continued support to help you achieve the maximum benefit and enjoyment available from your new fireplace.

Thank you for selecting a Lennox Hearth Products fireplace as the answer to your home supplemental heating needs.

## TABLE OF CONTENTS

Safety Rules .....	Page 2
Introduction .....	Page 3
Parts Required .....	Page 3
Optional Equipment.....	Page 3
EPA Qualified .....	Page 3
Operating The Fireplace .....	Page 4
Fuel .....	Page 4
First Fires .....	Page 4
Building a Fire .....	Page 4
Outside Air Register .....	Page 5
Refueling.....	Page 5
Closing the Doors .....	Page 5
Smoking – Causes And Troubleshooting .....	Page 5
Important Cautions .....	Page 5
Maintaining Your Fireplace.....	Page 6
Creosote.....	Page 6
Chimney Maintenance.....	Page 6
Dealing With A Chimney Fire.....	Page 6
Top Baffle Removal .....	Page 6
Door Frame Care.....	Page 6
Disposing of Ashes .....	Page 6
Refractory Replacement.....	Page 7
Door Adjustment.....	Page 7
How to use the retractable doors and firescreens .....	Page 7
Glass Care - Replacement .....	Page 8
Glass Care - Cleaning .....	Page 8
Gasket Replacement .....	Page 8
Fireplace Installation .....	Page 8
Locating the Fireplace .....	Page 8
Preinstallation .....	Page 9
Precautions .....	Page 9
Adjacent Wall .....	Page 9
Enclosure / Chase .....	Page 9
Mantel .....	Page 10
Hearth Extension Requirements .....	Page 10
Cold Climate Installations .....	Page 10
Fireplace and Framing Dimensions .....	Page 11
Insulated Chase Construction .....	Page 12
Fireplace Facing .....	Page 12
Outside Air Assembly .....	Page 13
UZY5 Blower Kit.....	Page 14
Forced Air Heating Kit .....	Page 14
Chimney System.....	Page 15
Chimney Installation Instructions .....	Page 16
Offset Chimney Installation .....	Page 17
Angled Wall Radiation Shield .....	Page 19
Universal Roof Support.....	Page 20
Chimney Chase And Multiple Terminations.....	Page 20
Chimney Adaptor .....	Page 20
Installation Accessories .....	Page 21
Chimney Components Lists .....	Page 22
Specifications.....	Page 23
Clearances .....	Page 23
Replacement Parts .....	Page 24
Product Reference Information .....	Page 26

## THE FIREPLACE

### INTRODUCTION

The Solana, EPA Low-Mass Wood-burning Fireplace Program qualified, is an energy efficient, heat circulating fireplace. You will receive a lifetime of comfort and enjoyment from your fireplace provided it is installed, maintained and operated properly.

- Please read these instructions and retain this manual for future reference.
- Before beginning the fireplace installation, consult the local authorities to obtain your building permit and check your local building codes. Install the fireplace only as described in these instructions and using only Lennox Hearth Products components.
- The Solana fireplace is NOT intended for use with an unvented gas log set. Do not use a fireplace insert or any other product with this fireplace unless it is specified by Lennox for use with this appliance. Failure to follow these instructions will void the certification and the warranty of the fireplace and may result in an unsafe installation.
- These appliances are NOT approved for Manufactured Home installations.

### PARTS REQUIRED

#### Fireplace Model Solana

- **8" diameter chimney** - Model Secure Temp™ ASHT 1", Secure Temp S-2100+ or AC manufactured by Security Chimneys International only, including:
  - Chimney lengths
  - Elbows (where necessary)
  - Associated components as per these Installation Instructions
- **Door** (included)
- **Outside Air Kit** (included)

NOTE: DIAGRAMS & ILLUSTRATIONS ARE NOT TO SCALE.

## OPTIONAL EQUIPMENT

- **Additional Equipment (optional)**
  - Trim Kit available in Nickel
  - UZY5 blower
  - VRUW Blower motor speed control
  - Forced Air Heating Kit ❶

❶ *If installed, this appliance no longer qualifies for EPA Low Mass Wood-burning Fireplace Program.*

## EPA WOOD-BURNING FIREPLACE PROGRAM QUALIFIED

This appliance has met the U.S. Environmental Protection Agency (EPA) Low Mass Wood-burning Fireplace Program Phase 2 emission level (g/kg), as per test protocol ASTM 2558 "standard test method for determining particulate matter emissions from fires in low mass wood-burning fireplaces".

Fresh Fire™  
Burn System



- 1- Air is diverted under the front of the grate, gaining heat from the ember and ash material for more efficient combustion.
- 2- Cool air is deflected to prevent cooling of the fire, so that high temperatures are maintained.
- 3- Efficient combustion leads to lower emissions, because the higher temperatures burn up more volatile gasses and particulates.
- 4- Exhaust air is effectively pulled into the chimney, and heat from the fire is circulated into the living space.

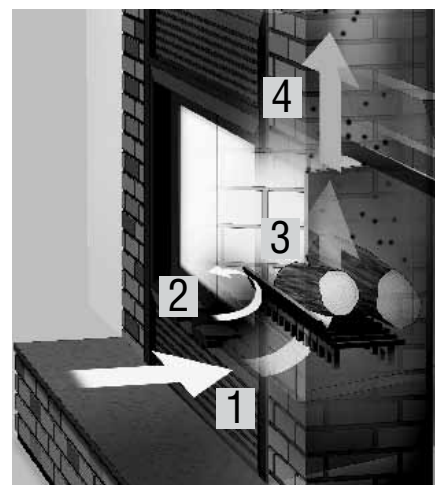

## OPERATING THE FIREPLACE

### Fuel

**USE SOLID NATURAL WOOD FUEL ONLY.** The Solana™ fireplace is designed to work best when fueled with seasoned natural wood only. Hardwoods are preferred to softwoods since the energy content of wood is relative to its density. Hardwoods will result in a longer burning fire and less frequent refueling. A moisture content of 15% to 20% (seasoned) is recommended. **Wood that has been cut and split and let to dry under a cover for a period of one year will usually meet that criteria.** The required drying time will vary depending on the climate. Wood that is packed tight together will take longer to dry. Seasoned wood is darker in color than wet wood and will have visible cracks in the grain on the ends. Excessively wet wood will be difficult to burn and will result in lower efficiency, increased creosoting and deposits on the glass and in the chimney. Excessively dry wood will burn well but will also have higher emissions and shorter burning time.

Do not burn scrap or garbage, treated wood or wood such as driftwood from the ocean which has been exposed to salt or other chemicals. Salt or chemicals can corrode the firebox and chimney. Do not burn large amounts of paper, cardboard, Christmas tree branches or building construction materials. Intense firing with these materials may overheat the fireplace, causing damage to the unit, a fire or even possibly igniting a chimney fire if the chimney is creosoted. Burning unapproved fuel, resulting in excessive pollutants being emitted, may be prohibited and subject to a fine or other penalty by the authority having jurisdiction in your area.

Processed firelogs can be used. Refer to firelog warnings and caution markings on the packaging prior to use.

### First Fires

**Before using the fireplace make sure to remove the plastic wrapping on plated door. Remove any glue residue left by the label using mild soap.**

The first five or six fires should be small fires of short duration (about 30 to 60 minutes). This will help cure the refractory bricks. During the first few fires of this appliance there may be some odor and smoke due to the curing of the paint, dust accumulation and burning off of lubricants used in the manufacturing process. It may set off a smoke alarm located in the same room. For this reason the room should be well ventilated for the first few fires.

## Building A Fire

### (starting and maintaining a fire)

To start a fire, place several crumpled up balls of newspaper in the firebox. Place small dry pieces of kindling on top of the paper, criss-crossing the kindling so that there are air spaces in between. Keep the fuel far back enough so that air can get underneath. Open the air controls fully and light the newspaper. Once the newspaper and the kindling is well ignited, close the firescreens. Once the kindling fire is well established, cord wood can be added (see *How To Use The Outside Air Register* section for proper operation of the air controls).

The unit will burn best with 2-3 pieces of cord wood spaced 1/2 to 1 inch apart and allowing air to get under the fuel. Criss-crossing or arranging the fuel so that air can get underneath, will help the fire to get started easily. The unit should be operated with the air control fully open long enough to get the cord wood well ignited.

**For the Fresh Fire™ system to burn efficiently, air must flow through the bottom of the grate and up in between the logs. Do not let ashes stack up to a height which will obstruct the opening between the base of the firebox and the bottom of the log retainer.**

NOTE: DIAGRAMS & ILLUSTRATIONS ARE NOT TO SCALE.

## HOW TO USE THE OUTSIDE AIR REGISTER (FIREPLACE)

The outside air register is located on the upper left part of the top louver. The outside air register supplies oxygen to the fire and allows control of the fire when the doors are closed. The fresh air must come from outside the house (the air intake must not draw air from inside the house). This will minimize negative pressure in the house. The more you slide the register to the left, the more fresh air into the firebox and the more accelerated combustion you will get (see **Figure 1**). When starting a fire, the register should always be fully opened.

For information on when you should start closing the register, see "Refueling" section.

## REFUELING

The Solana™ fireplace will operate best if attention is given to operating the unit with the outside air register fully opened (see **Figure 1**) after refueling in order to bring the firebox and the chimney system up to their optimum operating temperature. Combustion efficiency is relative to firebox temperature. To obtain this temperature, the fireplace must be operated with the primary air fully opened during 10 to 20 minutes after reloading, depending on the heat and on the moisture content of the wood. Once you have reached the desired temperature, the outside air register control can be set to a medium setting. The benefit of this technique will be cleaner glass, less creosoting, greater efficiency and the most pleasing fire for your enjoyment.

Set the air register to the full open position before opening the doors to reduce the possibility of smoke entering the home from the fireplace.

## CLOSING THE DOORS

As soon as a layer of embers covers the surface under the log retainer, it is possible to close the doors with the outside air register opened.

Closing the doors prematurely may result in:

- The firebox filling with smoke;
- The flame intensity cuts down excessively.

Meaning the fireplace is not hot enough to close the doors.

## SMOKING – CAUSES AND TROUBLESHOOTING

To reduce the likelihood of smoking when opening the door, set the outside air register to the left before opening the door. Your fireplace has been designed and tested to provide smoke free operation. Occasionally, there may be a small amount of smoking upon lighting the fire, until the chimney heats up but this should not continue. If the fireplace continues to smoke it is probably for one of the following reasons:

### A. The doors are partially opened

When you open the doors, open them completely.

### B. Negative pressure in the house

As the fire burns, air goes up the chimney. This air must be replaced through leakage into the house or through the outside air duct. When operating the Solana™ fireplace, open a nearby window temporarily to check if there is adequate replacement air supply.

### C. Fans operating (e.g.: range hood)

Fans such as range hoods or bath fans draw air out of the house and may actually cause a negative pressure in the house. Turn off all fans and open a nearby window to determine if this is the cause of the problem.

### D. Wet wood

Wet or tarred wood will smoulder and smoke instead of burning properly. Your dealer can help you determine if you have properly seasoned wood for burning.

### E. Dirty or blocked chimney

Check to make sure the chimney is clear and clean. If dirty call a certified chimney sweep or use a properly sized chimney brush to clean.

### F. Chimney not long enough

The minimum chimney height is twelve (12) feet (3.7 m) not including the fireplace height. The chimney must extend at least three (3) feet (915 mm) above its point of contact with the roof and at least two (2) feet (610 mm) higher than any roof or wall within ten (10) feet (3 m) of it. When installed with one offset, the minimum chimney height is fifteen (15) feet. Additional height will increase draft and will decrease the tendency to smoke.

### G. Poor chimney draft

With no fire, there should be sufficient draft to exhaust cigarette smoke introduced under the chimney. Chimneys installed against an outside wall without protection may generate back draft problems which will cause start-up problems. To prevent this, open a nearby window, roll up a piece of paper and light it. Then, hold it in the upper part of the firebox to warm up the chimney. Wait until the draft is sufficient, then start the fire.

## IMPORTANT CAUTIONS

- Do not block the hot air vents to the fireplace as this will cause the fireplace to overheat.**
- Never use gasoline, gasoline-type lantern fuel, kerosene, charcoal lighter fluid, or similar liquids to start or 'freshen up' a fire in this fireplace. Keep all such liquids well away from the fireplace while it is in use.**
- Do not burn coal. The sulphur in coal will corrode the firebox and chimney.**
- Keep combustible materials at least 48" (1.2 m) away from the front of the fireplace opening.**
- Never leave children unattended when there is a fire burning in the fireplace.**
- Do not use the Solana™ as an incinerator to burn paper, cardboard or construction material such as pressed wood, plywood or lumber. Use only untreated wood. Wood protectors, metallic paper, coal, plastic, waste, beach wood, Christmas tree, sulphur and/or oil will damage the fireplace.**
- Do not burn driftwood which has been in the ocean or salt water. The salt will corrode the firebox and chimney.**
- Do not burn wood in the area in front of the log retainer.**
- Do not allow the wood to smoulder or burn without flame, since this will produce excessive creosote in the unit as well as increased particulate emissions.**

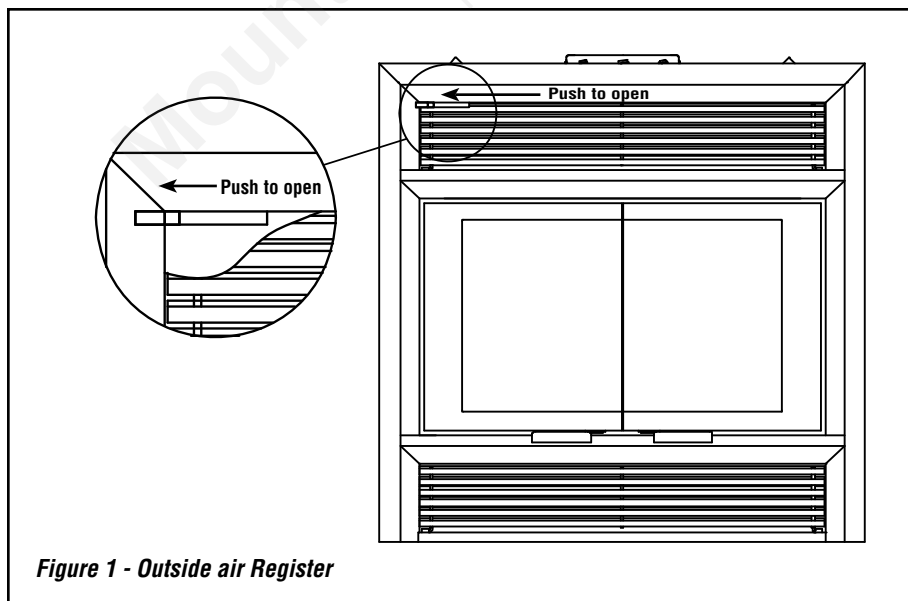

**Figure 1 - Outside air Register**

NOTE: DIAGRAMS & ILLUSTRATIONS ARE NOT TO SCALE.

## MAINTAINING YOUR FIREPLACE

### Creosote - Formation and Need for Removal

When wood is burned slowly, it produces tar and other organic vapors, which combine with expelled moisture to form creosote. The creosote vapors condense in the relatively cool chimney flue of a slow-burning fire. As a result, creosote residue accumulates on the flue lining. When ignited this creosote makes an extremely hot fire.

The chimney shall be inspected at least twice a year during the heating season to determine when a creosote buildup has occurred.

When creosote has accumulated it shall be removed to reduce the risk of a chimney fire.

When the creosote accumulation is large, a creosote fire in the chimney can damage the chimney and overheat the surrounding wood framing. Creosote formation in a chimney can be minimized by making sure there is always visible flame burning, avoid smouldering fires and by proper refuelling techniques.

### Chimney Maintenance

Regular chimney inspection and maintenance combined with proper operation will help prevent chimney fires. Keep your chimney clean. Do not allow more than a 1/16" (1.6mm) build-up of creosote in your chimney. The amount of creosote will depend on variables such as frequency of use and type of fire. We recommend that you:

- A. Initially, inspect the chimney system weekly. By doing this, you will learn how often it will be necessary to clean your chimney.
- B. Have your chimney cleaned by a qualified chimney sweep. If you wish to clean it yourself, we recommend using a stiff plastic or non-metallic brush. If a metal brush is used, its size should be slightly smaller than the flue to avoid damaging the chimney. Do not use a brush that will scratch the stainless steel interior of the chimney.
- C. Do not expect chemical cleaners to keep your chimney clean. The raincap can be removed for inspection and/or cleaning of the chimney. Unscrew the braces which attach the raincap to the chimney. Using gloves, firmly grip the upper portion of the rain cap. Turn the cap and lift it off the chimney.

**Caution:** It is necessary to remove the baffle from the top of the firebox before cleaning the chimney.

### Dealing With a Chimney Fire

Regular chimney maintenance and inspection can prevent chimney fires. If you have a chimney fire, follow these steps:

1. Close the fireplace glass doors and the air inlet.
2. Close the chimney outside air register.
3. Alert your family of the possible danger.
4. If you require assistance, alert your fire department.
5. If possible, use a dry chemical fire extinguisher, baking soda or sand to control the fire. Do not use water as it may cause dangerous steam explosions.
6. Watch for smouldering or fire on combustibles next to the fireplace and chimney. Check outside to ensure that sparks and hot embers coming out of the chimney are not igniting the roof.
7. Do not use the fireplace again until your chimney and fireplace have been inspected by a qualified chimney sweep or a fire department inspector.

### Top Baffle Removal Prior to Cleaning The Chimney

Before starting to clean your chimney, we recommend that you remove the top baffle to avoid creosote dust collection at the top of the baffle. Follow these steps to set the top baffle out of the way:

1. Remove the baffle refractory and its iron angle support (figure 2);
2. Obstruct the dilution air box inlet, located in the upper back of the firebox, with a metal or cardboard sheet;
3. Close the chimney damper and doors;
4. Proceed with chimney sweep;
5. Open the chimney damper before opening the doors;
6. Clean out the firebox;
7. REMOVE the metal or cardboard sheet, placed in step #2, and re-install the baffle and its iron angle support.

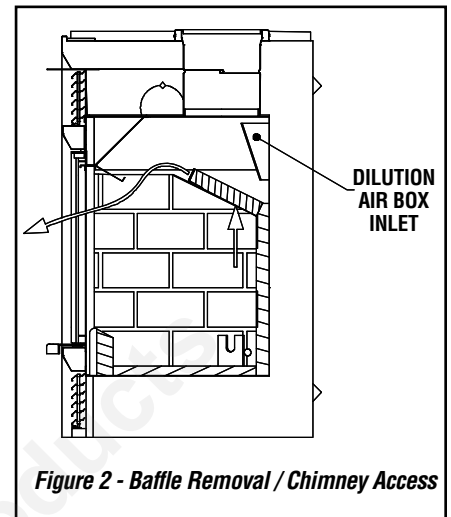

### Door Frame Care

Use a glass cleaner and a soft cloth to polish the frame. Do not use abrasives such as steel wool or steel pads for they may scratch the door frame finish.

### Disposing Of Ashes

Remove ashes only when the fire is out and the ashes are cold (24 to 48 hours after the fire is out).

Ashes removal must be performed regularly during the operating season. An excess of ashes will block the airflow and risks to increase the particle emissions. In order to burn efficiently, do not let ashes stack up to a height which will obstruct the opening between the base of the firebox and the bottom rod of the log retainer.

Rotate the log retainer on the back refractory and remove the ashes. Make sure the log retainer is properly leaning on the back refractory, in case its rotation is obstructed.

Do not leave the ashes in the house as they give off carbon monoxide and other toxic gases.

**⚠ WARNING**

**Disposal of Ashes: Ashes should be placed in a metal container with a tight fitting lid. The closed container of ashes should be placed on a non-combustible floor or on the ground well away from all combustible materials, pending final disposal. If the ashes are disposed of by burial in soil or otherwise locally dispersed, they should be retained in the closed container until all cinders have thoroughly cooled.**

NOTE: DIAGRAMS & ILLUSTRATIONS ARE NOT TO SCALE.

## REFRACTORY REPLACEMENT

The intense heat of the fire will normally cause hairline cracks in the refractory. These cracks can be minimized by proper curing as described in "First Fires". They will not normally diminish the effectiveness of the refractory. If large cracks develop, then the refractory should be replaced. To replace the refractory bricks, follow these steps (see **Figure 4**):

1. Remove the baffle refractory and its iron angle support;
2. Remove the front refractory;
3. Remove the bottom refractory;
4. Remove the sides refractories \* ;
5. Remove the back refractory.

\* Hold the back refractory when the last side refractory is removed, to prevent the back refractory to fall in the firebox.

## DOORS ADJUSTMENT

Glass doors may lose their adjustment during transportation or installation of the fireplace. A wrong adjustment may cause a loss in combustion's efficiency and control. The glass doors must be parallel, at the same height and must almost touch each other when closed. Maximum spacing between the door's glass is one sixteenth of an inch (1/16").

The glass doors can be adjusted by loosening the three (3) screws of the hinges' supports (see fastening screws in **Figure 5**). If a minor angular adjustment is needed, you may loosen only two (2) of the three (3) screws using the other as a pivot point.

## HOW TO USE THE RETRACTABLE DOORS AND FIRESCREENS

The Solana™ fireplace features retractable doors and firescreens in order to allow a wider view of the fire and save space when the doors are opened. To retract the doors, simply open them at 90° and push them into the opening on the side of the firebox. The same procedure applies for the retractable firescreens. (see **Figure 3**).

**Note:** Do not operate the fireplace with both fire-screen and doors closed at the same time.

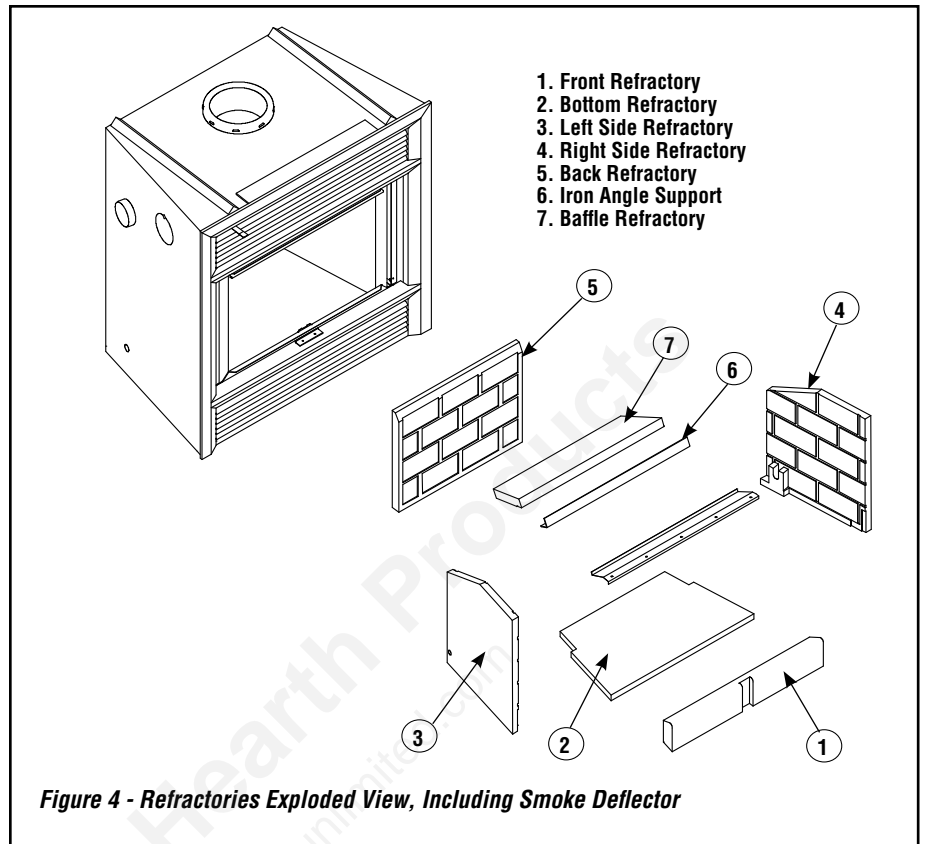
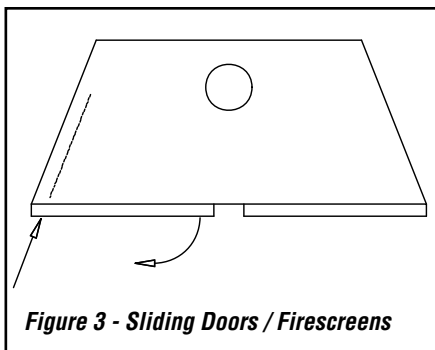

## ! WARNINGS

- Use only a Lennox Hearth Products glass doors, specifically designed for the Solana fireplace.
- The fireplace cannot be operated without doors or firescreens. Consult your dealer to select the correct replacement door(s) or firescreen(s).
- Important! To assure proper alignment of glass doors: Install this fireplace in a square and plumb condition, using shims as necessary at sides and/or bottom.

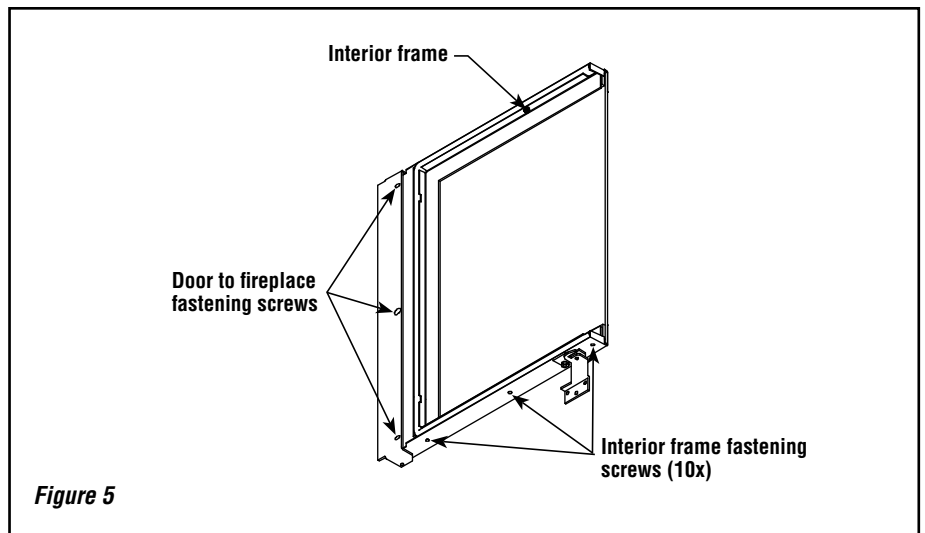

NOTE: DIAGRAMS & ILLUSTRATIONS ARE NOT TO SCALE.

## GLASS CARE

### Glass Replacement

The glass used for the Solana™ fireplace is a high temperature ceramic glass (1,400° F/760° C). If the glass breaks, it must be replaced with an identical ceramic glass. Tempered glass or ordinary glass will not withstand the high temperatures of the Solana fireplace. Replacement glass should be purchased from a Lennox Hearth Products dealer (see “Replacement Parts”, **Pages 24 and 25**). **DO NOT OPERATE THE UNIT WITH CRACKED OR BROKEN GLASS.** To remove the glass, unscrew the frame fastening screws (see **figure 5**), remove the interior frame and the glass.

### Glass Cleaning

The Solana™ fireplace is designed to keep the glass clean under normal operating conditions. To clean the glass there are a number of specially designed cleaners. Your authorized Lennox Hearth Products dealer can recommend a suitable cleaner. Regular household glass cleaners will not clean creosote. **Do not use abrasives such as steel pads, steel wool or oven cleaner as they will scratch the glass.**

**DO NOT USE CHEMICAL GLASS CLEANERS ON PAINTED SURFACES AS IT MAY CAUSE THE PAINT TO PEEL.**

**CAUTION: DO NOT ALLOW WINDOW CLEANER TO GET IN CONTACT WITH DOOR GASKET OR PAINT ON FACADE OR DOOR. ONCE CLOSED, CONTACT OF GLASS CLEANER WITH THE FIREPLACE FACADE CAN PROVOKE PAINT PEELING OFF.**

## Gasket Replacement

Remove the doors from the unit (see **Page 6**) and lay each door on a clean unabrasive surface. To replace the gasket, first remove all of the old gasket and gasket cement. Make sure that the surface is totally clean before applying new cement (a high temperature silicone caulking rated at 500° F [260° C] is suitable) or adhesion problems may result. Apply gasket cement to the gasket channel and install the new gasket. This replacement part is available from your Lennox Hearth Products dealer in the following dimensions:

Gasket *	Length **	Dimensions	Part No.
Upper Door Gasket	31 (787)	3/4" dia. (19mm)	PR-COGR2035
Lower Door Gasket	16 (406)	3/4" dia. (19mm)	PR-COGR2035A

**Table 1** \* Note: Requires one each for one door  
\*\* Note: Inches (millimeters)

## FIREPLACE INSTALLATION

### Locating The Solana Fireplace

A. The best location to install your fireplace is determined by considering the location of windows, doors, and the traffic flow in the room where the fireplace is located, allowing space in front of the unit for the hearth extension and the mantel, and taking into consideration the location of the outside air kit and chimney.

If possible, you should choose a location where the chimney will pass through the house without cutting floor or roof joists (see fireplace dimensions **Page 10**).

- B. Usually, no additional floor support is needed for the fireplace. The adequacy of the floor can be checked by first estimating the weight of the fireplace system. Weights are given in the appendix. Note the floor construction and consult your local building code to determine if additional support is needed.
- C. The Solana fireplace may be installed directly on the floor or on a raised base (for proper guidelines, refer to “Hearth Extension Requirements”) and a minimum of 7 ft (2.1 m) measured from the base of the appliance to the ceiling is required.

When selecting the location, the chimney outlet position and the direction of the wind are important factors affecting the chimney performance. To allow a maximum draft and to reduce wind turbulence, the chimney must:

- Penetrate the highest part of the roof.
- Be installed as far as possible from roof offsets, trees or any other obstructions that may cause wind turbulence and back drafts in the chimney.
- The least amount of offsets (elbows) possible.

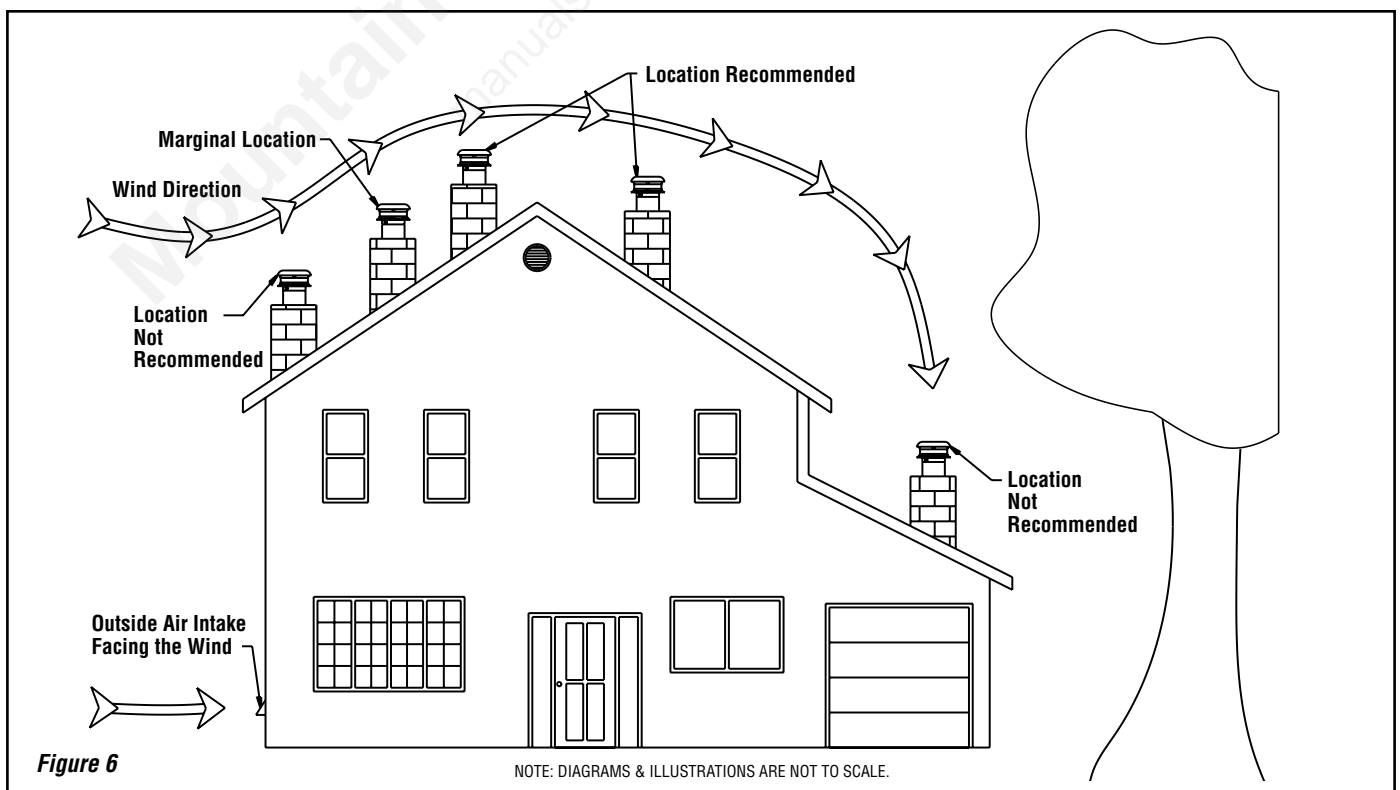

## Preinstallation

### Please Read Before Installing:

1. Before beginning the installation of your fireplace, read these safety tips and installation instructions carefully to be sure you understand them completely. Failure to follow them could cause a fireplace malfunction resulting in serious bodily injury and/or property damage.
2. The Solana™ fireplace has been tested and listed to UL and ULC standards by Warnock Hersey International Inc. These instructions were written to give you an outline for a fast and safe installation and reliable operation. Failure to use Lennox Hearth Products parts or conduct variations in techniques and construction materials described in this installation manual may create a serious fire hazard and may void the warranty and the WHI listing.
3. **Always check your local building codes. The installation must comply with their regulations. Before beginning the installation, consult the local authorities and make sure your building permit complies with their requirements.**
4. This fireplace must be installed with Security Chimneys™ chimney system models ASHT+, S-2100+ or AC, of 8" inside diameter. The chimney system must always vent to the outside of the building.
5. To maintain top efficiency and to prevent build-up of soot and creosote, inspect and clean the chimney periodically during the heating season.
6. To prevent possible hazards due to poor combustion and to avoid affecting other fuel burning appliances (furnace, wood stove, etc.), ensure that the outside air kit is properly installed.
7. This fireplace is designed to allow the installation of a gas burner. In such a case, the installation must conform with the National Gas Code ANSI Z223.1 and Z21.60.

## WARNING

**When using a gas burner, it is mandatory to keep the chimney outside air register opened.**

8. This fireplace has provision for the installation of a gas pipe and is intended only for connection to a decorative gas appliance incorporating an automatic shutoff device and complying with ANSI Z21.60-M96/CGA 2.26-M96, Standard for Decorative Gas Appliances for Installation in Solid-Fuel Burning Fireplaces (reference Clause 4.1.3 T).
9. The Solana™ fireplaces are sold with factory installed doors. **The outside combustion air kit is mandatory** and is included with the fireplace. Optional blowers and decorative trims are available.

## Tools And Building Supplies Normally Required

### Tools:

Phillips screwdriver  
Slot style screwdriver  
Hammer  
Saw and/or Sabersaw  
Level  
Measuring tape  
Plumb line  
Electric drill and bits  
Pliers  
Square

### If gas pipe is used:

Pipe wrench  
Pipe cutter  
Pipe threader  
Pipe joint compound  
Pipe key valve

### Building supplies:

2" x 3" or heavier lumber  
Drywall panel or equivalent  
Silicone caulking (non-combustible)  
Overlay material for fireplace façade  
Hearth extension (non-combustible)

## PRECAUTIONS!

The most important areas of concern dealing with the fireplace installation are clearances to combustible materials, secure assembly of components parts, the height of the chimney system, the proper use of accessory equipment and the techniques used in using finishing materials applied to fireplace surrounds, hearth extensions and wall coverings. Each of these topics will be covered in greater detail throughout this manual. **Please give special attention to these instructions as you progress with your installation.**

## Fireplace Installation Procedure

1. Move the fireplace into the desired position (follow the recommendations below for enclosure).
2. Install the outside air assembly (or assemblies) - refer to **Page 13**.
3. Install the enclosure surrounding the fireplace (see **Pages 9 through 12**).
4. Install the hearth extension (see **Page 10**). Make sure the gap between the fireplace and the hearth extension is sealed.

## LOCATING THE FIREPLACE

Do not place the fireplace on carpeting, vinyl or other soft surface floor coverings. It may, however, be directly placed on flat wood, plywood, particle board or other hard surface materials.

## ADJACENT WALL

A wall perpendicular to and in front of the fireplace front facing must be at least 18" (460mm) from the fireplace opening. A wall at 45° to the front facing and starting at the fireplace's outer edge is permitted. Projections within this area are permitted. See **Figure 7**.

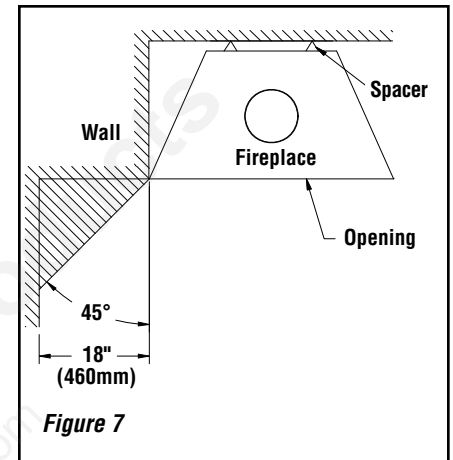

## ENCLOSURE

1. **WARNING:** Do not place loose insulation or any other material in the space around the fireplace or the chimney. Insulation placed on or around the fireplace or chimney may cause adjacent wood to overheat and catch on fire.
2. The fireplace must be installed against a finished wall (like drywall finish). It must not be installed against a vapor barrier or exposed insulation (see **Figure 10**).
3. The fireplace is zero clearance. Combustible materials like wood, plywood, particle board or drywall can be in direct contact with the fireplace reinforcements. **Two inch (50 mm) clearance to combustibles must be kept around the chimney.**
4. **WARNING:** The top of the fireplace is not zero clearance. Do not place any insulating material in the space above the fireplace for a height of 7 feet from the base of the fireplace.
5. Do not block the fireplace's hot air vents or air inlets as this will cause the fireplace to overheat.

## CHASE ENCLOSURE

A chase is a vertical box-like structure constructed to surround the fireplace and chimney. Refer to **Figure 10** for a typical chase configuration. A chase should be constructed and insulated just like any outside wall. In a cold climate, we recommend the base of the chase should also be insulated between the solid continuous base beneath the fireplace and the outside base. Chase insulation in a cold climate installation is not required for safety.

## Mantel

A wood mantel, if installed, must be at least 48" (1.2 m) above the base of the fireplace (see **Figure 8B**). There is no restriction regarding the length or the width of the mantel.

## Hearth Extension Requirements

(refer to **Figures 8A and 8B**)

A non-combustible hearth extension must be built in front of the fireplace and extend out on both sides. Hearth extensions must be constructed according to the following guidelines:

1. A layer of sheet metal 0.018" (0.45mm) thick or 3/8" (9mm) thick insulating board or any other material (tiles, marble, granite) with equivalent heat resistance may be used. Check with the local building authorities before installing to determine what other materials are acceptable in your area.
2. The hearth extension should be secured to the floor. The gap between the fireplace and the hearth extension must be sealed. The supplied safety metal strip must be positioned as follows: One half under the front of the fireplace and the other half must extend on the floor over which the hearth extension will be built (see **Figure 8A**).

\* The safety metal strip must cover the entire width of the fireplace.

3. On a raised base or raised hearth, a "Z" shape piece of metal must be fabricated to join the bottom of the fireplace to the floor (see note 1 in **Figure 8A**).

Hearth extension of an elevated fireplace must respect the same minimal dimensions as a fireplace installed directly on the floor (figure 8B).

## Cold Climate Installations

**Climates where temperatures will fall below 32° F (0° C).**

The heating performance of the appliance will vary depending upon the level of insulation, house design, how the appliance is operated, etc.

If this fireplace is being installed in a cold climate, it is especially important to seal all cracks around the fireplace and wherever cold air could enter the room with noncombustible material. Also, the outside air inlet duct should be wrapped with noncombustible insulation to minimize the formation of condensation. Do not place insulation materials directly against the chimney sections. We recommend that you use the insulated wall radiation shield since it will maintain the home's thermal barrier. AC chimney is NOT recommended in very cold climates (in areas with temperatures often get below 0°F (-18°C)).

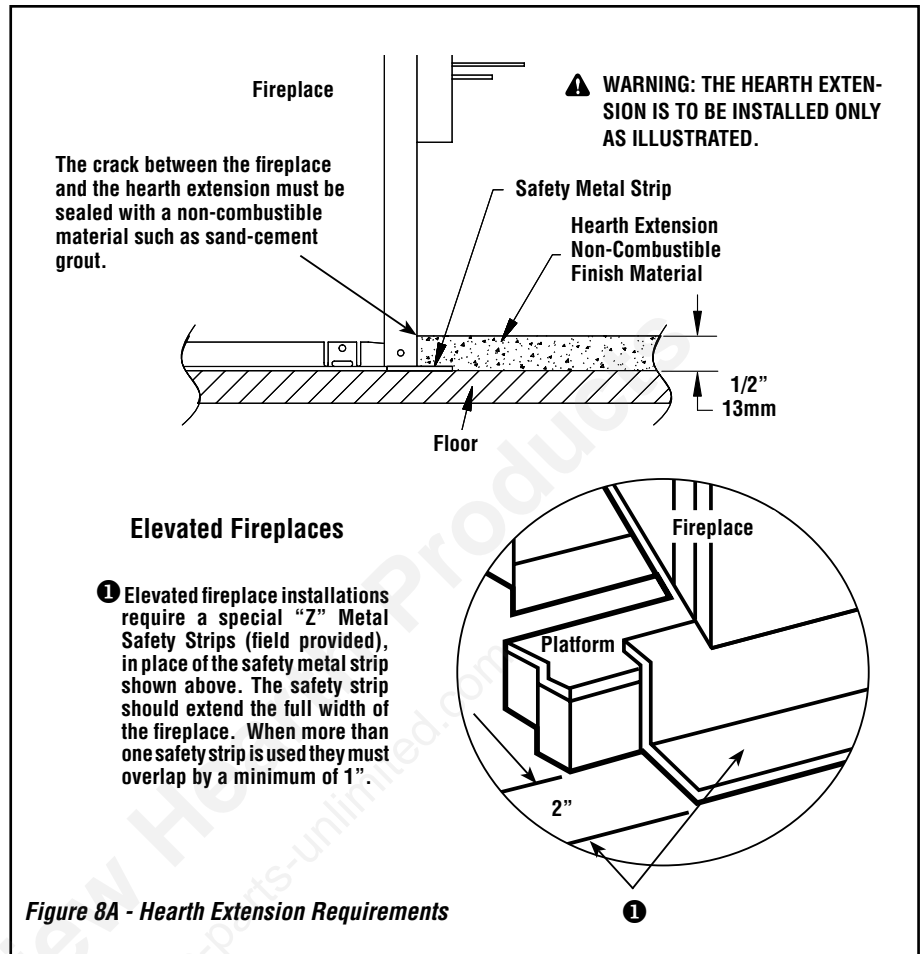

**Figure 8A - Hearth Extension Requirements**

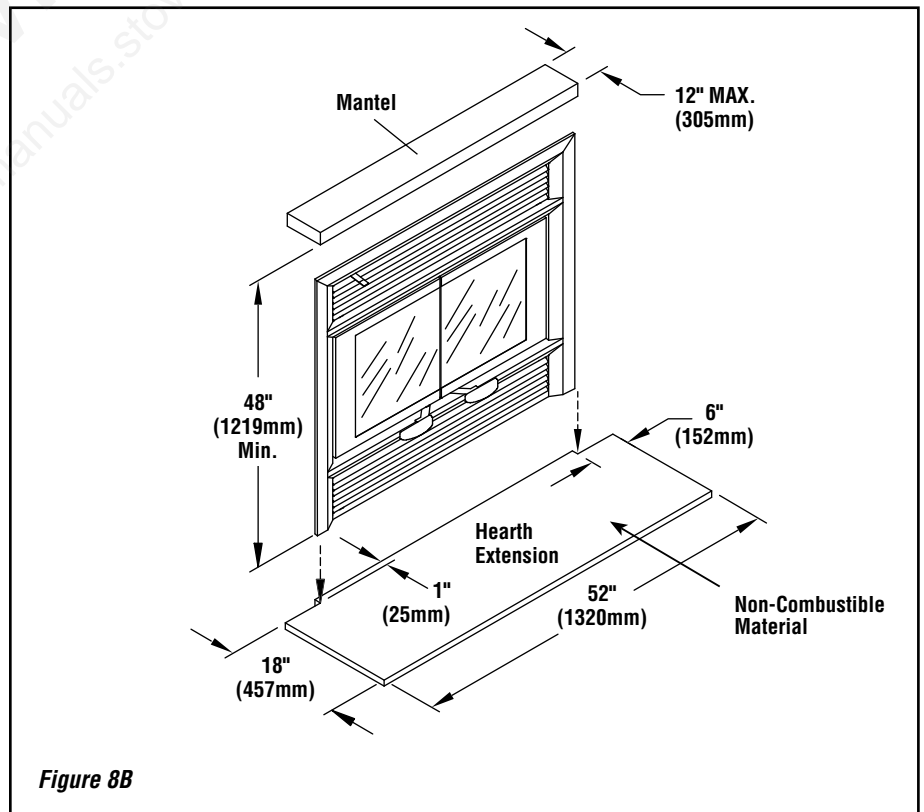

**Figure 8B**

NOTE: DIAGRAMS & ILLUSTRATIONS ARE NOT TO SCALE.

**Corner Installation**

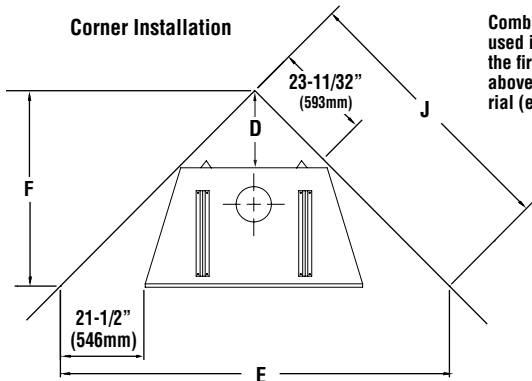

Combustible materials can NOT be used in the space directly above the fireplace. Do not fill the space above the fireplace with any material (except the wood framing)

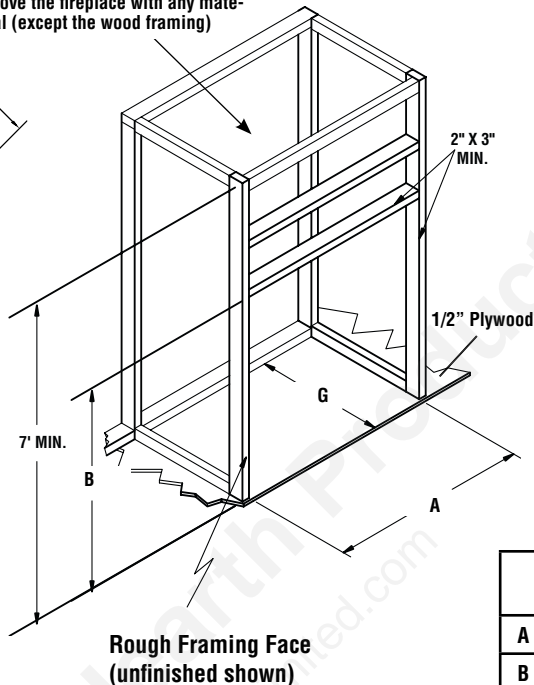

**Notes**  
 Due to Lennox Hearth Products ongoing commitment to quality, all specifications, ratings and dimensions are subject to change without notice.  
 All framing dimensions calculated for 1/2" dry wall at the fireplace face. If sheathing the chase or finishing with other thickness materials, calculations will need to be made.  
 \* The fireplace must not be in contact with any insulation or loose filling material. Cover the insulation with Drywall panels around the fireplace.

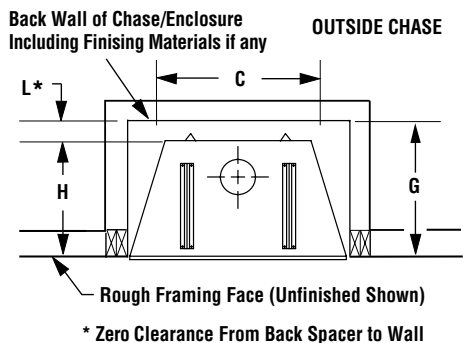

FRAMING DIMENSIONS Fireplace Opening Width		
A	43-1/4"	1099 mm
B	43-1/4"	1099 mm
C	33"	838 mm
D	16-1/2"	419 mm
E	85"	2159 mm
F	42-1/2"	1080 mm
G	27"	686 mm
H	26"	660 mm
J	60-1/8"	1527 mm
K	8"	203 mm
L	1"	25 mm

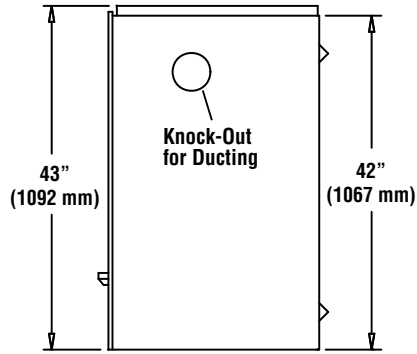
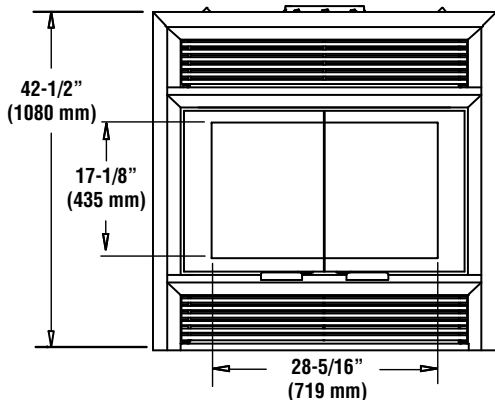
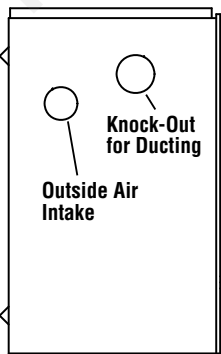
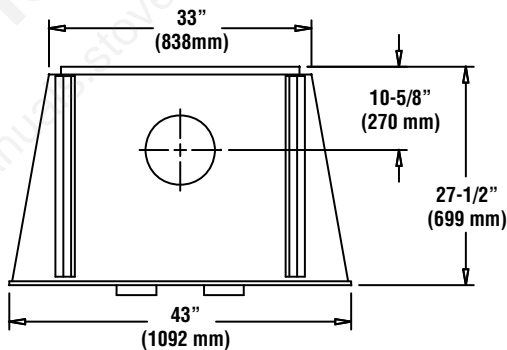
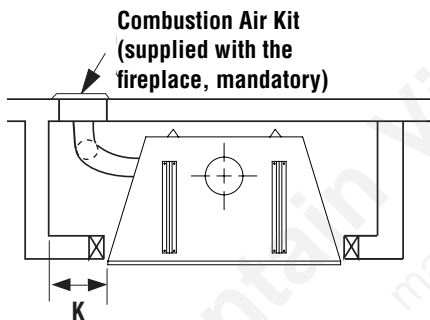

**Figure 9 - Framing Dimensions**

NOTE: DIAGRAMS & ILLUSTRATIONS ARE NOT TO SCALE.

## Insulated Chase Construction

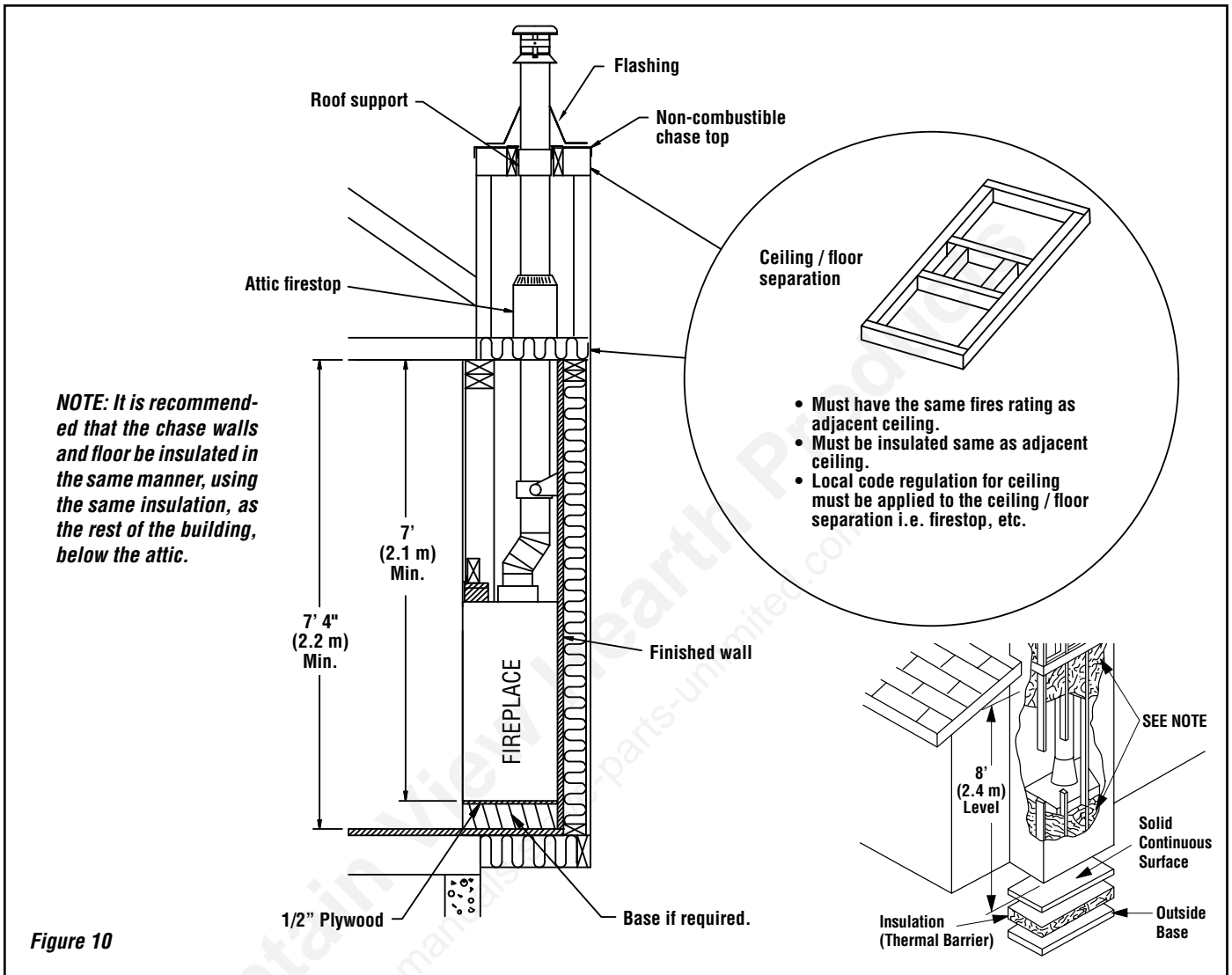

## Nailing Flanges

Four nailing flanges are provided to secure the fireplace to the floor (see figure below). Bend the nailing flanges down so that each flange is flush with the floor, then using nails or screws, secure the fireplace to the floor (2 places each side). The heads of the screws or nails must be large enough to completely cover the holes in the nailing flanges.

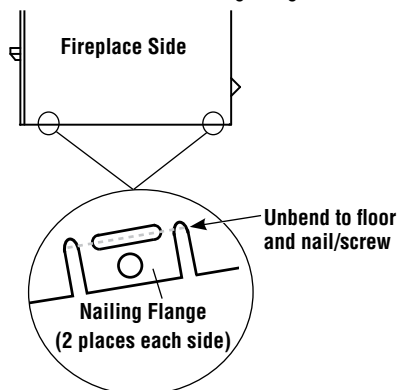

## Fireplace Facing

The fireplace should be framed using 2" x 3" (50mm x 75mm) or heavier lumber.

**Figure 9 on Page 11** shows the general framing layout.

Combustible materials must be installed flush with the fireplace facing. They may not project out in front of the fireplace. Non-combustible materials such as brick, stone or ceramic tile, may project in front of and/or on the fireplace facing.

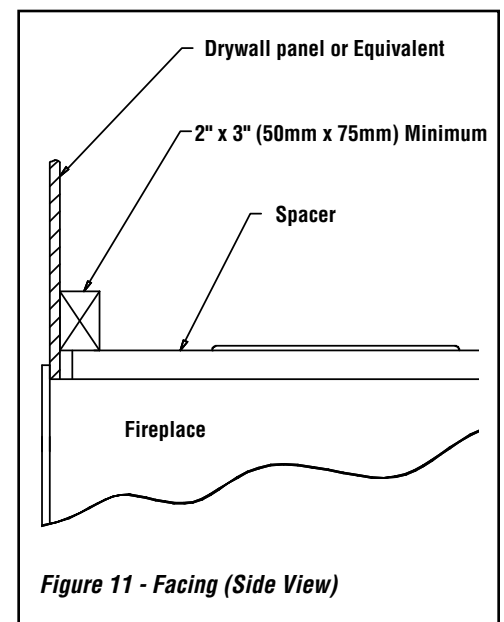

NOTE: DIAGRAMS & ILLUSTRATIONS ARE NOT TO SCALE.

## Outside Air Assembly (Fireplace and AC Chimney)

The outside air assembly is **mandatory** for the fireplace and the AC chimney.

During operation, the fireplace requires air for combustion and draws air out of the house. It may starve other fuel burning appliances such as gas or oil furnaces. As well, exhaust blowers and blower driven appliances may compete for air, causing a negative pressure in the home, resulting in smoke entering the home from the fireplace. This situation is aggravated in modern airtight houses.

To overcome this potential problem, **the installation of an outside air assembly is required** to provide outside combustion air to the fireplace.

## Outside Air Installation (Fireplace and AC Chimney)

The outside air assembly must be installed according to the following guidelines:

1. The maximum length of 4" I.D. (100 mm) insulated flexible duct is 20 feet (6.1 m). If a longer duct is required, use a 6" I.D. (150mm) insulated flexible duct. The maximum length is 40 feet (12 m). Refer to **Figures 12B and 12C** for connections.
2. The duct and register may be installed above or below floor level.
3. The outside air register must not be installed more than 10 feet (3.1 m) above the base of the fireplace.
4. The outside air assembly must draw air from outside the house. It must not draw air from the attic, the basement or a garage (see **Figure 6 on Page 7**).
5. Locate the outside register where it will be well away from automobile exhaust fumes or other vents.
6. The outside air register should be installed where it is not likely to be blocked by snow or exposed to extreme wind.
7. It is recommended to install the outside air register at floor level. However, if you must raise the air register above the fireplace level, you will have to make a loop to the floor with the flexible pipe to prevent from causing a draft in the outside air register (see **Figure 12 Detail A**).

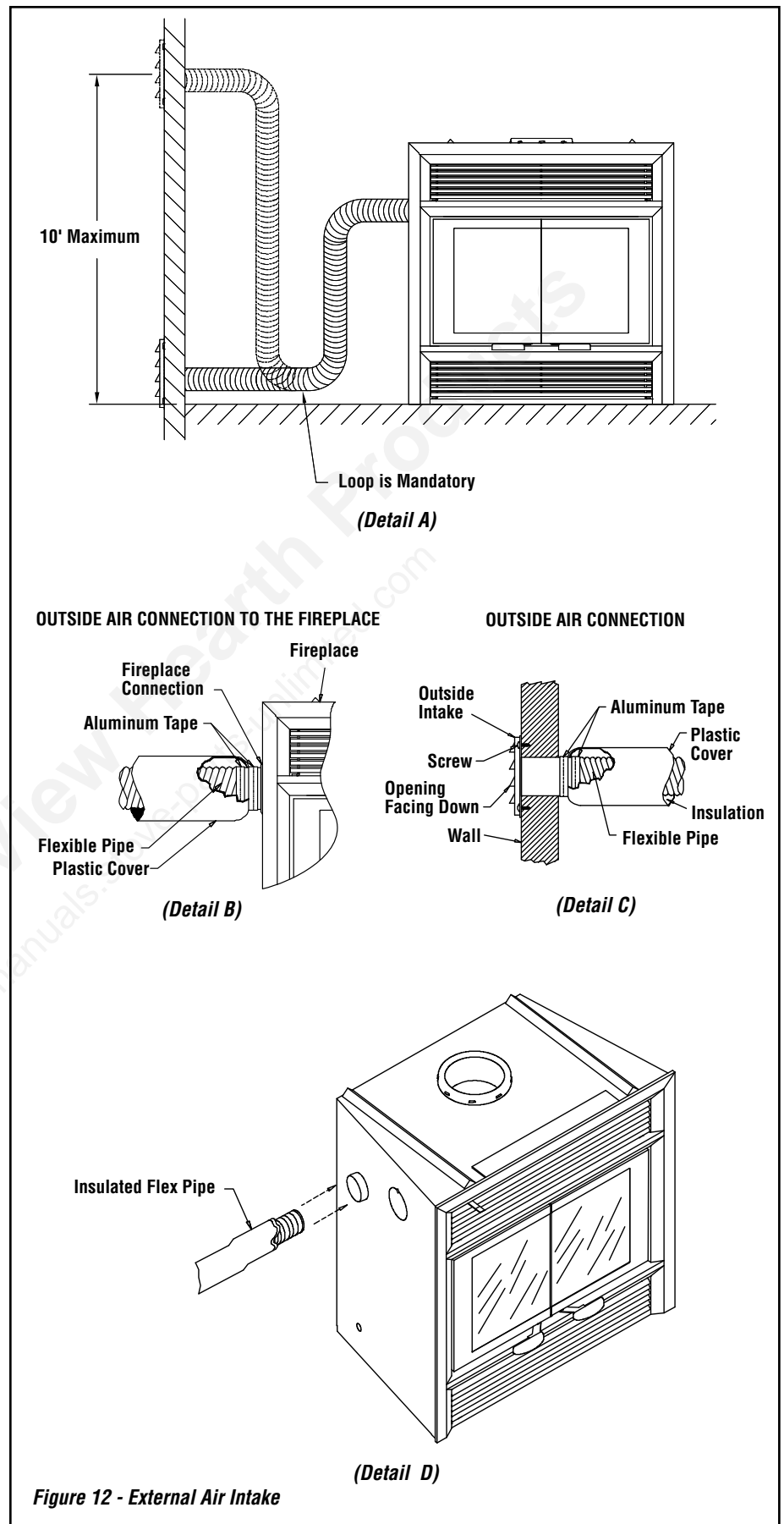

Figure 12 - External Air Intake

NOTE: DIAGRAMS & ILLUSTRATIONS ARE NOT TO SCALE.

## INSTALLATION OF THE BLOWER KIT MODEL UZY5

**NOTE:** This blower kit can easily be installed when the fireplace has a pre-installed junction box. You just have to plug them in.

**Rating: 120 Volts, 60Hz, .63A.**

The blowers have magnetic blower mounts. The junction box (factory installed on approved fireplaces for the use of this blower kit) must be connected to 120 VAC service before permanently enclosing the fireplace. The access hole for connecting the 120 VAC is located on the lower right exterior side of the fireplace.

### Installation instructions:

1. Open the bottom louver of the fireplace.
2. Place each blower kit into the fireplace side opening 1" from the back of the fireplace.
3. Install the automatic blower activator on the side of the firebox (the blower activator has a magnetic mount).
4. Plug the blower kit into the junction box.
5. Ground both blowers to the back panel using the green screws (see **Figure 13**).

**NOTE:** The fireplace must be electrically connected and grounded in accordance with local codes or in the absence of local codes, with the current CSA C22.1 Canadian Electrical Code. For U.S.A. installations, follow local codes and the National Electrical Code ANSI/NFPA No 70.

**CAUTION: SHOULD THIS BLOWER REQUIRE SERVICING, THE POWER SUPPLY MUST BE DISCONNECTED.**

These blowers require periodic maintenance. Check the area in front of the blowers and wipe or vacuum at least once a month during the burn season.

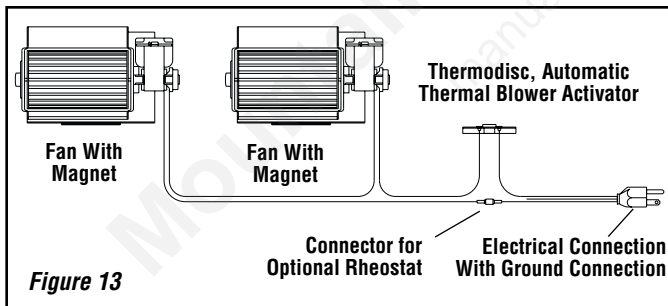

## CENTRAL FORCED AIR KIT

**If this kit is installed, this appliance no longer qualifies for EPA Low Mass Wood-burning Fireplace Program.**

The knock-outs provided on the sides of the Solana™ fireplace allow the connection of insulated flexible pipe which enables you to heat adjacent rooms up to 50 feet from the fireplace.

The ducting system must be installed as described below:

1. Fix the adaptor at the side of the fireplace by twist-locking the adaptor to the fireplace. You can use more than one outlet on the fireplace (**Figure 14**).
2. Attach the 5" flexible pipe, using the collars provided. **Important: Make sure that the plastic wrapping around the flexible pipe will not be in contact with the fireplace.**
3. Route the flexible pipe to the chosen location. The ducting system can be installed either in an upper room or in a lower room.
4. Attach the flexible pipe to the blower, using the collars (**Figure 15**).
5. Fix the decorative grill blower adaptor to the blower.
6. Attach a standard 3" x 10" grill to the adaptor.
7. Install the *blower thermostat* in that part of the house to be heated by the hot air duct. **Do not install** the *blower thermostat* in the room where the fireplace is located. A *cooling thermostat* can be installed in the same room as the unit. This thermostat will turn on the blower when the room where the fireplace is located becomes too hot.

This option requires electricity. Make sure that the connections to the blower have been made according to the local codes and comply with their requirements.

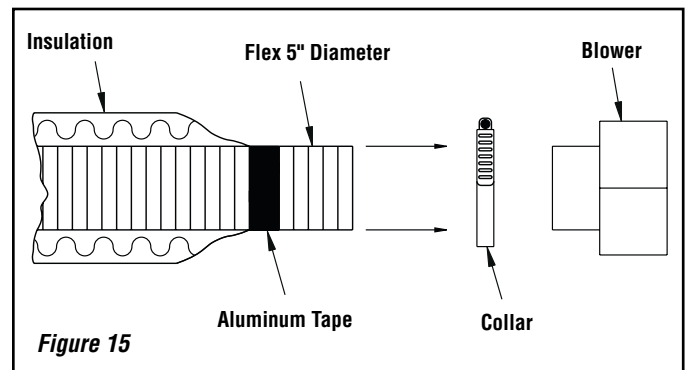
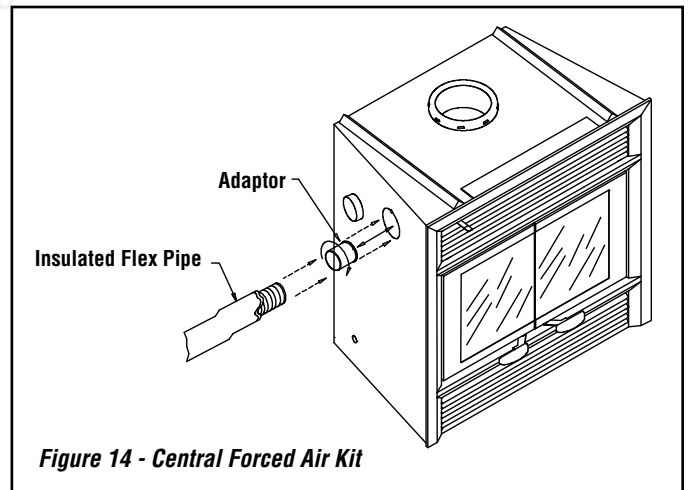

## CHIMNEY SYSTEM

### GENERAL INFORMATION

The Solana™ fireplace is listed only with Security Chimneys™ International Ltd. chimney systems, models ASHT+ 8", S-2100+ 8", or AC 8". **Do not connect the fireplace to a masonry chimney, chimney liner, or other brand of factory-built chimney.**

**The Oliver Macleod chimney models HT6103 and HT6000 are respectively equivalent to Security Chimneys International Ltd. Chimney models ASHT and S2100.**

In areas with continuous temperatures below 0° F (-18° C), the use of an exterior chimney increases the likelihood of operating problems such as low draft, high rate of creosoting and poor start up characteristics. Exterior chimneys are also prone to down-drafting and flow reversal. Installations located in a basement, in combination with outside chimneys, are especially prone to flow reversal. In cold areas, air cooled chimneys should not be used in an exterior installation.

**Caution: AC chimney should not be used in very cold areas, where temperatures are likely to fall below 0° F (-18° C), or altitudes above 4000 feet.**

A chimney venting a fireplace shall not vent any other appliance.

The minimum system heights are indicated in **Table 2**.

In altitude, add 18" (450mm) to the chimney for every 2000 feet (600 m) above sea level.

All chimney installations must include at least one support. The maximum length of chimney that can be supported by the fireplace is 12 feet (3.6 m) for S-2100+, 18 feet (5.4 m) for ASHT+ and 26 feet (8 m) for AC chimney.

The chimney must extend at least 3 feet (915mm) above its point of contact with the roof and at least 2 feet (610mm) higher than any wall, roof or building within 10 feet (3 m) of it (see **Figure 18**).

If the chimney extends higher than 5 feet (1500mm) above its point of contact with the roof, it must be secured using a roof brace or guide wires.

A rain cap must be installed on top of the chimney. Failure to install a rain cap may cause the fireplace to corrode and operate inefficiently.

Cut and frame square holes in all floors and the roof to provide a 2" (50mm) clearance between the chimney and any combustible materials. Do not fill this 2" (50mm) space with any material (see **Figure 19**).

Portions of the chimney which may extend through accessible spaces must be enclosed to avoid contact with combustible materials or damage the chimney.

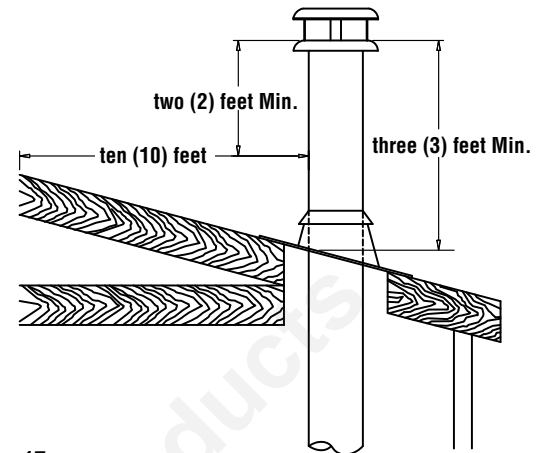

**Figure 17**

**Minimum System Heights**

Fireplace Model	Solana™
Chimney Model	ASHT+ / S-2100+ / AC
Vertical Installation	12 feet (3.66 m)
One Offset (2 elbows)	15 feet (4.57 m)
Two Offsets (4 elbows)	17 feet (5.18 m)

**Table 2**

**Note:** 2" clearance to combustibles around chimney components required.

**Note:** Blown or fill type insulation materials must not be in contact with the fireplace or in the enclosure frame as described in "Enclosure" section.

**Note:** Local codes may not require firestopping at the ceiling levels for outside chase installations. However, it is recommended for safety and the reduction of heat loss.

### Chimney Height

The total height of your completed fireplace system from the surface the fireplace rests on to the chimney top must not exceed 60'. Chimney height must also meet minimum height requirements, excluding the fireplace height, indicated in **Table 2**. Refer to the minimum system height chart.

In altitude, add 18" (450 mm) to the chimney for every 2000 feet (600 m) above sea level.

## CHIMNEY INSTALLATION INSTRUCTIONS

1. Cut and frame the holes in the ceiling, floor and roof where the chimney will pass (see **Figure 19**). Use a plumb-bob to line up the center of the holes. The hole sizes are indicated in **Table 3** for the floor and ceiling holes and in **Table 4 (Page 17)** for the roof holes.

CHIMNEY MODEL 8"	SQUARE HOLE SIZE OPENING
ASHT+ / HT6103+	14-3/8" (365 mm)
S-2100+ / HT6000+	16" (406 mm)
AC	15" (380 mm)

*Note: See Table 4 for Sloped Roof Framing  
Table 3 - Flat Roof Framing*

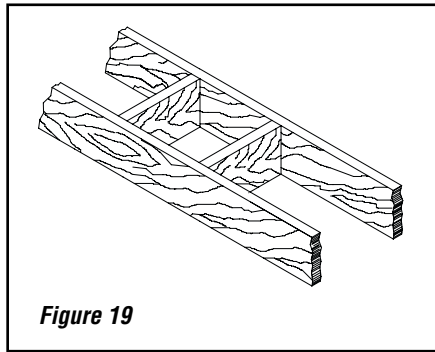

**Figure 19**

2. From below, install a firestop in each ceiling/floor separation through which the chimney will pass. At the attic level, install an attic radiation shield from above (see **Figures 20A and 20B**).
3. For ASHT+ and S-2100+ chimneys, place the first chimney length on the fireplace. To lock it into place, turn 1/4 of a turn clockwise. With the AC chimney you must use a starting section before installing the first chimney length (see **Figure 21**). Continue installing chimney lengths making sure to lock each length in place.
4. Every time the chimney passes through a roof or a wall, install the appropriate firestop. When you reach the desired height, install the roof support (see instructions included with the support).
5. Then, put the roof flashing in place and seal the joint between the roof and the flashing with roofing pitch. For sloping roofs, place the flashing under the upper shingles and on top of the lower shingles. Nail the flashing to the roof, using roofing nails (**Figures 22 and 23**).
6. Place the storm collar over the flashing and tighten it with the bolt supplied. Finally, seal the joint between the storm collar and the chimney, using silicone caulking.
7. Install the chimney cap. Once the chimney cap is in place, the roof flashing can be washed with a solvent or vinegar and then painted with rust-proof paint.

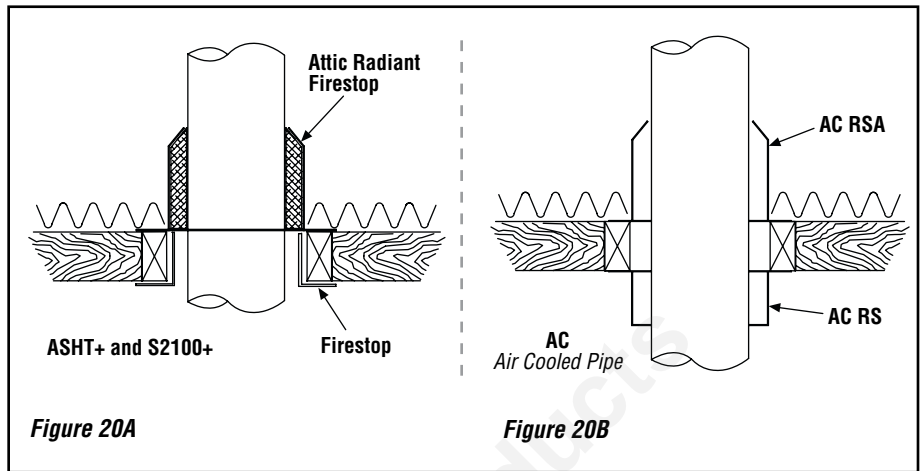

**Figure 20A**

**Figure 20B**

### AC CHIMNEY INSTALLATION (AIR COOLED INSULATED GALVALUME CHIMNEY)

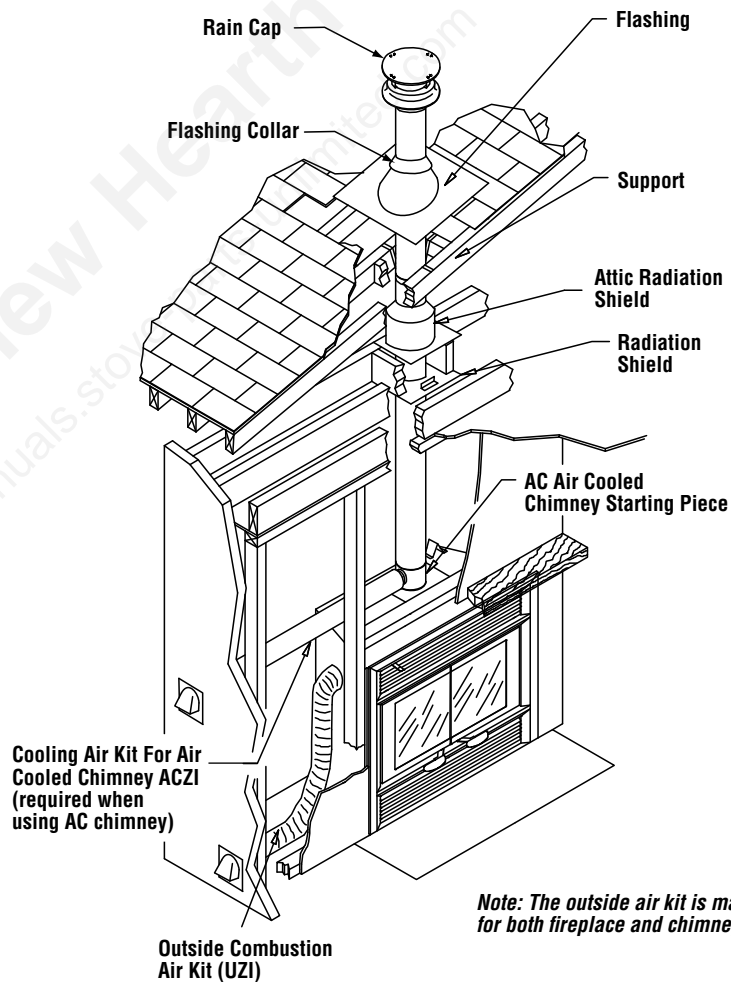

**Note: The outside air kit is mandatory for both fireplace and chimney**

**Figure 21**

NOTE: DIAGRAMS & ILLUSTRATIONS ARE NOT TO SCALE.

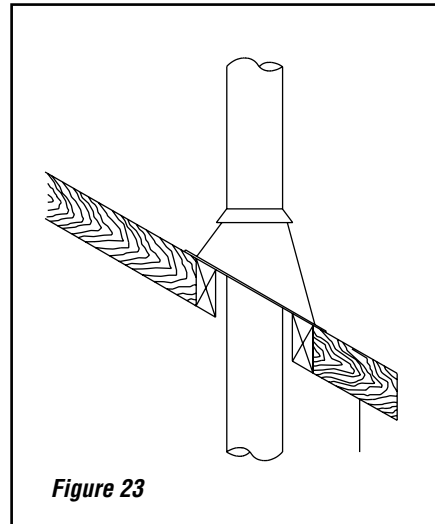
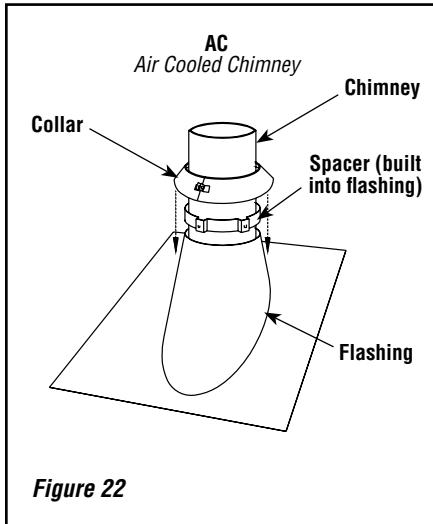

After reaching the location requiring the elbow, proceed as follows:

**ASHT+/HT6103+/S2100+/HT6000+ Chimneys**

1. Install the first elbow. Turn it in the required direction. Fasten it to the chimney with the three (3) 1/2" (12mm) metal screws provided.
2. Install the necessary lengths to achieve the required offset. Lock the chimney lengths together: it is recommended to use three (3) 1/2" (12mm) screws. If the offset length is made of two (2) chimney lengths use an offset support halfway up the offset. If penetrating a wall, install a wall radiation shield (see **Figure 27**).
3. Use another elbow to turn the chimney vertically. Secure the elbow, using three (3) 1/2" (12mm) screws (provided with the elbow).
4. Use a plumb-bob to line up the center of the hole. Cut a hole for the chimney in the ceiling/floor. Frame this hole as described previously (see *Chimney Installation Instructions* on **Page 16**).
5. From below, install a radiation shield (**Figure 20A**).
6. A support (ST+ or SO+) must be used on the first 15 feet section (5 m).
7. Continue with the regular installation.

**AC chimney**

1. Install the first elbow. Turn it in the required direction. To lock it in place, turn 1/8 of a turn. Fasten the straps attached to the elbow to the surrounding framing using nails or drywall screws (**Figure 25**).
2. Install the necessary chimney lengths to achieve the required offset. Lock the chimney lengths together. If penetrating a wall, use a wall radiation shield (**Figure 27**).
3. Use another elbow to turn the chimney vertically. Lock it to the chimney. Fasten the straps attached to the elbow to the surrounding framing using nails or drywall screws.
4. Use a plumb-bob to line up the center of the hole. Cut a hole for the chimney in the ceiling. Frame this hole as described previously.
5. From below, install a radiation shield (see **Figure 20B**).
6. Continue with the regular installation.

**Note:** When using AC chimney, an AC8SB (H3801) starter section must be used before installing an elbow. When an offset is needed immediately off the top of the fireplace, an elbow starter section, AC8SB30 (H3802) is available.

Roof Down Slope Hole Size			
SLOPE	ASHT+	S-2100+	AC
Roof Pitch	8"	8"	8"
0 *	14-3/8" (365mm)	16" (406mm)	15" (380mm)
2/12	14-5/8" (371mm)	16-1/4" (413mm)	15-3/8" (390mm)
4/12	15-1/4" (387mm)	16-7/8" (429mm)	16-1/8" (410mm)
6/12	16-1/8" (410mm)	17-7/8" (454mm)	16-7/8" (430mm)
8/12	17-3/8" (441mm)	19-1/4" (489mm)	18-1/4" (465mm)
10/12	18-3/4" (476mm)	20-7/8" (530mm)	19-5/8" (500mm)
12/12	20-3/8" (518mm)	22-5/8" (575mm)	21-3/8" (545mm)

\* Cross slope hole size  
Put the chimney cap into place.  
Wash the roof flashing with a solvent or vinegar, then paint it with rust-proof paint.

**Table 4**

**OFFSET CHIMNEY INSTALLATION**

After reaching the location requiring the elbow, proceed as follows. The minimum chimney height excluding the fireplace height is shown in **Table 2**.

**Notes:**

- Must return to vertical before penetrating ceiling or floor.
- A maximum of 2 offsets are allowed.

### Offset Dimensions

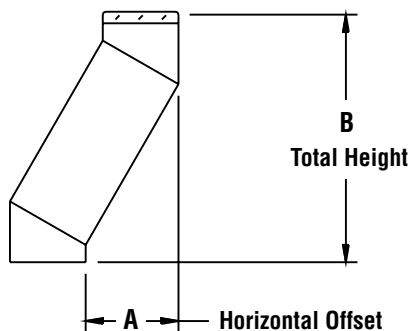

Chimney 8"	Elbow	Offset & Height	One Length Between Elbows					Two Lengths Between Elbows						
			8"	12"	18"	24"	36"	48"	8" & 48"	12" & 48"	18" & 48"	24" & 48"	36" & 48"	48" & 48"
Secure Temp ASHT +	15°	A	3-5/16" (84mm)	4-5/16" (110mm)	5-7/8" (149mm)	7-7/16" (189mm)	10-1/2" (267mm)	13-5/8" (346mm)	15-3/8" (391mm)	16-7/16" (418mm)	18" (457mm)	19-1/2" (495mm)	22-5/8" (575mm)	25-3/4" (654mm)
		B	15-11/16" (398mm)	19-9/16" (497mm)	25-3/8" (645mm)	31-3/16" (792mm)	42-3/4" (1086mm)	54-3/8" (1381mm)	60-15/16" (1548mm)	64-13/16" (1646mm)	70-9/16" (1792mm)	76-3/8" (1940mm)	87" (2210mm)	99-9/16" (2529mm)
	30°	A	7-7/16" (189mm)	9-7/16" (240mm)	12-7/16" (316mm)	15-7/16" (392mm)	21-7/16" (545mm)	27-7/16" (697mm)	30-13/16" (783mm)	32-13/16" (833mm)	35-13/16" (910mm)	38-13/16" (986mm)	44-13/16" (1138mm)	50-13/16" (1291mm)
		B	20" (508mm)	23-1/2" (597mm)	28-11/16" (729mm)	33-7/8" (860mm)	44-1/4" (1124mm)	54-11/16" (1389mm)	60-9/16" (1538mm)	64" (1627mm)	69-1/4" (1759mm)	74-7/16" (1891mm)	84-13/16" (2154mm)	95-1/4" (2419mm)
Nova Temp HT6103+	45°	A	10-5/16" (262mm)	13-3/16" (335mm)	17-3/8" (441mm)	21-5/8" (549mm)	30-1/8" (765mm)	38-5/8" (981mm)	43-7/16" (113mm)	46-1/4" (1175mm)	50-1/2" (1283mm)	54-3/4" (1391mm)	63-1/4" (1607mm)	71-11/16" (1818mm)
		B	17-13/16" (452mm)	20-5/8" (524mm)	24-7/8" (632mm)	29-1/8" (740mm)	37-5/8" (956mm)	46-1/8" (1172mm)	50-15/16" (1294mm)	53-3/4" (1365mm)	58" (1473mm)	62-1/4" (1581mm)	70-3/4" (1797mm)	79-3/16" (2011mm)

Chimney 8"	Elbow	Offset & Height	One Length Between Elbows					Two Lengths Between Elbows						
			8"	12"	18"	24"	36"	48"	8" & 48"	12" & 48"	18" & 48"	24" & 48"	36" & 48"	48" & 48"
Secure Temp S2100+	15°	A	3-5/16" (84mm)	4-5/16" (110mm)	5-7/8" (149mm)	7-7/16" (189mm)	10-1/2" (267mm)	13-5/8" (346mm)	15-1/2" (394mm)	16-1/2" (419mm)	18-1/16" (459mm)	19-5/8" (498mm)	22-3/4" (578mm)	25-13/16" (656mm)
		B	16" (406mm)	19-7/8" (505mm)	25-11/16" (652mm)	31-1/2" (800mm)	43-1/16" (1094mm)	54-5/8" (1387mm)	61-7/16" (1561mm)	65-1/4" (1657mm)	71-1/16" (1805mm)	76-7/8" (1953mm)	88-1/2" (2248mm)	100-1/16" (2542mm)
Nova Temp HT6000+	30°	A	7-3/8" (187mm)	9-3/8" (238mm)	12-3/8" (314mm)	15-3/8" (391mm)	21-3/8" (543mm)	27-3/8" (695mm)	30-7/8" (784mm)	32-7/8" (835mm)	35-7/8" (911mm)	38-7/8" (987mm)	44-7/8" (1140mm)	50-7/8" (1292mm)
		B	20-11/16" (525mm)	24-3/16" (614mm)	29-3/8" (746mm)	34-9/16" (878mm)	44-15/16" (1141mm)	55-5/16" (1405mm)	61-3/8" (1559mm)	64-7/8" (1648mm)	70-1/16" (1780mm)	75-1/4" (1911mm)	85-5/8" (2175mm)	96" (2438mm)

Chimney 8"	Elbow	Offset & Height	One Length Between Elbows					Two Lengths Between Elbows						
			---	12"	18"	---	36"	48"	---	12" & 48"	18" & 48"	---	36" & 48"	48" & 48"
AC 8"	15°	A	---	4-13/16" (122mm)	6-1/8" (156mm)	---	11" (280mm)	14-1/8" (359mm)	---	16-7/8" (429mm)	18-7/16" (468mm)	---	23" (584mm)	26-3/16" (665mm)
		B	---	27-11/16" (703mm)	33-1/2" (851mm)	---	50-7/8" (1292mm)	62-1/2" (1588mm)	---	72-5/8" (1845mm)	78-7/16" (1992mm)	---	95-3/4" (2432mm)	107-3/8" (2727mm)
	30°	A	---	9-3/8" (238mm)	12-3/8" (314mm)	---	21-3/8" (543mm)	27-3/8" (695mm)	---	32-5/8" (829mm)	35-5/8" (905mm)	---	44-5/8" (1134mm)	50-5/8" (1286mm)
		B	---	25-3/4" (654mm)	31" (787mm)	---	46-1/2" (1181mm)	57" (1448mm)	---	66" (1676mm)	71-1/4" (1810mm)	---	86-7/8" (2207mm)	97-1/4" (2470mm)

**NOTE:** With the AC chimney, a starting length of 6" high must be used on top of the fireplace before installing an elbow.

Figure 24

### OFFSET CHIMNEY INSTALLATION

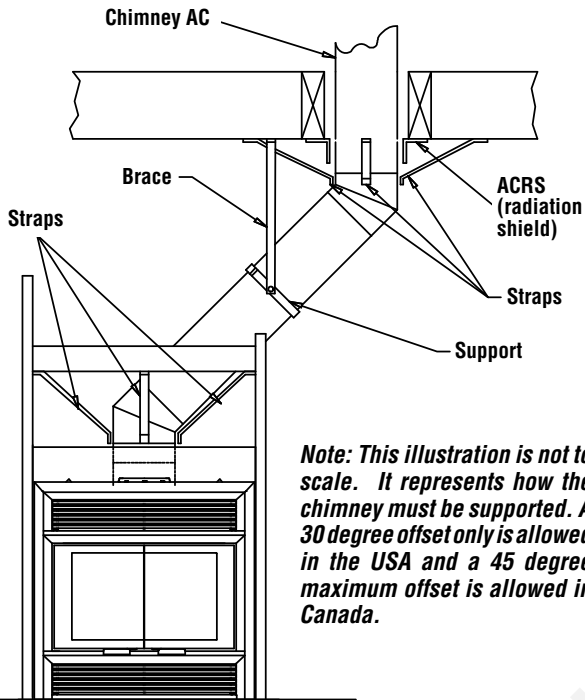

*Note: This illustration is not to scale. It represents how the chimney must be supported. A 30 degree offset only is allowed in the USA and a 45 degree maximum offset is allowed in Canada.*

Figure 25

### OFFSET CHIMNEY INSTALLATION WITH WALL PENETRATION

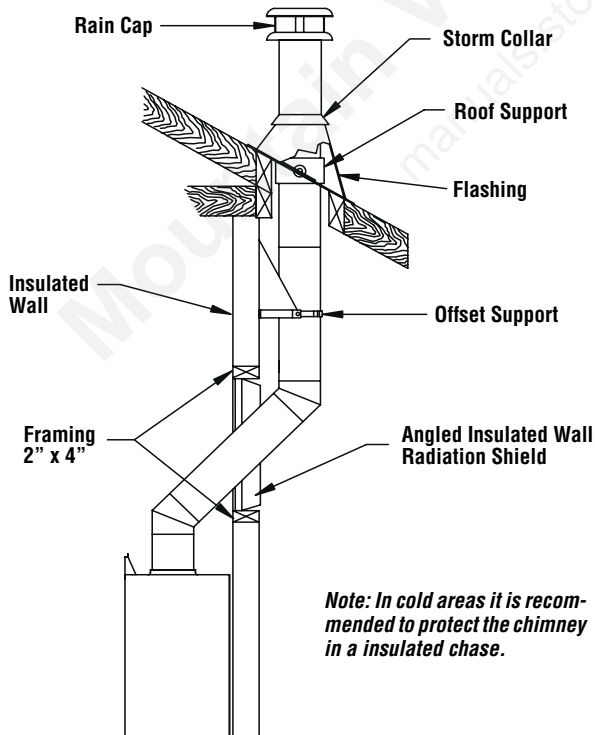

*Note: In cold areas it is recommended to protect the chimney in a insulated chase.*

Figure 26

### ANGLED WALL RADIATION SHIELD (RSM+, RSMI30, RSMI45)

When traversing a combustible wall with the chimney at a 30° or 45° angle, an angled firestop and/or wall radiation shield must be installed. Only one is required (Figure 27). Table 6 gives recommended hole size for installing a wall radiation shield.

**Note: 45° angle installation for Canada only.**

In cold climate locations (climates where temperatures will fall below 32° F / 0° C), we recommend that you use the insulated wall radiation shield since it will maintain the home's thermal barrier.

RSM+ and RSMI30, RSMI45		
Chimney Model	Angle	Hole Size
ASHT+ (8" I.D.)	30°	14-3/8" x 36-1/2" (365mm x 927mm)
Canada Only	45°	14-3/8" x 24-3/4" (556mm x 629mm)
S-2100+ (8" I.D.)	30°	16" x 40" (406mm x 1016mm)
Canada Only	45°	16" x 27-1/4" (406mm x 692mm)
AC (8" I.D.)	30°	15-1/4" x 38-1/4" (365mm x 927mm)

Table 6

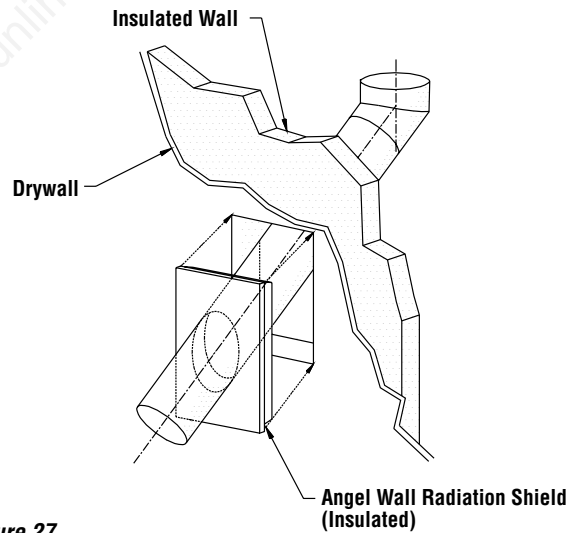

Figure 27

## UNIVERSAL ROOF SUPPORT INSTALLATION

This support has three possible uses:

1. For ASHT+ and S-2100+ chimneys, it must be used on a roof to support the chimney.
2. It may be used on a floor, ceiling or roof above an offset to support the chimney above the offset.
3. It may be used on a floor, ceiling or roof as a supplementary support when the chimney height exceeds 15 feet (4.6 m.).

**Table 7** gives maximum height of supported chimney.

**NOTE:** For the AC chimney, a support section (AC8SL) must be used every 40' (12 m) instead of the universal roof support (ST).

For roof support installation, refer to the instructions provided with the support.

### Universal Offset Support

This support is used to support the chimney above an offset. When the chimney offset is used to traverse a wall, this support may be used on the wall to support the chimney. The maximum heights are given in **Table 7**. For offset support installation, refer to the instructions provided with the support.

Chimney Model	MAXIMUM HEIGHT OF SUPPORTED CHIMNEY	
	Offset Support	Roof Support
ASHT+ 8" I.D.	20 feet (6.10 m)	24 feet (7.32 m)
S-2100+ 8" I.D.	14 feet (4.30 m)	16 feet (4.87 m)
AC 8" I.D.	40 feet (12.19 m)	50 feet (15.20 m)

*Table 7*

### CHIMNEY CHASE AND MULTIPLE TERMINATIONS

For the purpose of this manual, a chimney chase is considered a part of the chimney system rather than part of a building. The termination must be placed a minimum of 18" (460mm) above the chase.

For installation where more than one chimney is located in the same chase or within the same general area, **we suggest** that their terminations be separated by at least 16" (410mm) horizontally and 18" (460mm) vertically. This separation is to prevent smoke migrating from one chimney to another (see **Figure 28**).

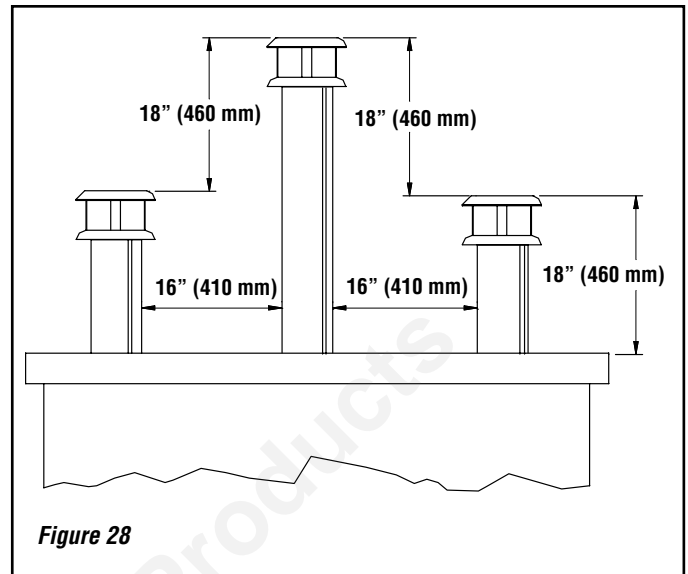

**Figure 28**

### CHIMNEY ADAPTOR (S-2100+ / HT6000+) CANADA ONLY

The fireplace is normally supplied with a chimney adaptor suitable for the ASHT / HT6103+ chimney. If you want to install a S-2100+ / HT6000+ chimney, an adaptor is available (8UCA) (**Figure 29**). A separate starter section will also be required if AC chimney is installed.

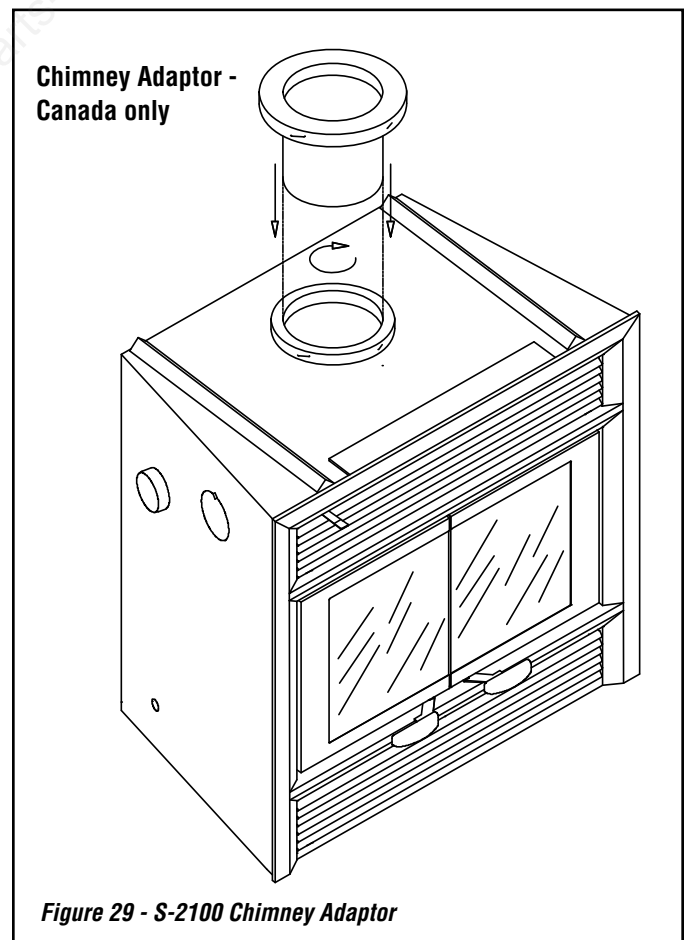

**Figure 29 - S-2100 Chimney Adaptor**

## OPTIONAL INSTALLATION ACCESSORIES - SOLANA™

Installation Accessories	
Description	Cat./ Part No.
<b>Outside Air Kit (Required - Included with Fireplace)</b>	
Outside Air Coupler to connect outside air UZI to fireplace, UZIAD	UZIDF
Outside Air Ducting - Includes 4" insulated flex x 10 ft. long, UZI	UZI
<b>Fireplace Options</b>	
Horizontal Trim Kit - Brushed Nickel	H3395
Blower	UZY5
Blower Motor Speed Control	VRUW

### Fireplace Model Solana™ - Approved Venting Components

**8" Diameter Chimney** - Model ASHT+, S-2100+, HT6000+, HT6103+ or AC manufactured by Security Chimneys International only.

#### Notes:

1. (Projet NovaTemp™) HT6000+ is equivalent to S-2100+
2. (Projet NovaTemp™) HT6103+ is equivalent to ASHT+
3. This appliance is equipped with the ASHT Chimney Adaptor. When other chimney is used, a chimney adaptor for the chimney will be required.
4. Chimney Adaptor (S-2100+ / HT6000+) for CANADA ONLY - If you want to install a S2100+ / HT6000+ chimney, an adaptor is available (8UCA).
5. AC Chimney is Not recommended at elevations above 4000 feet or in very cold climates where temperatures are likely to fall below 0° F (-18° C). When using AC chimney, an AC8SB (H3801) starter section must be used before installing an elbow. When an offset is needed immediately off the top of the fireplace, a starter section, AC8SB30 (H3802), is available.

Installation Accessories	
Description	Cat./ Part No.
<b>Forced Air Heating Kit</b>	
<b>Starter Kit includes:</b> blower (BISZY), flex adaptor and two clamps (BISAF), blower variable speed control (VRUW), Thermo-disc (VTU), blower flex adaptor (BISAVF), and back draft damper (BISBD)	BISFWK-1
<b>Flex - Choose 15 feet or 25 feet depending on installation</b>	
Flex 5 inches ID x 15 feet Long	5FLEX15
Flex 5 inches ID x 25 feet Long	5FLEX25
<b>Starter Kit Separate Components</b>	
Blower flex adaptor, includes damper (BISBD)	BISAVF
Blower - 250 CFM	BISZY
Flex adaptor and two clamps for fireplace connection	BISAF
Blower motor speed control	VRUW
Thermo-disc - turns motor on when fireplace is hot and off when cool	VTU
Back draft damper	BISBD
<b>Options</b>	
Heating / Cooling Thermostat - 110V	HCTW

## COMPONENTS LIST - SOLANA™

<b>Secure Temp™ ASHT+ High Temp. Insulated Stainless Steel Chimney</b> <i>8" Diameter, Listed to CAN / UCL-S604 and UL-103HT at 1200° F</i>	
Description	Cat./ Part No.
<b>Lengths and Misc. Chimney Components</b>	
8" Length, 8" Dia., 8L8	8L8
12" Length, 8" Dia., 8L12	8L12
18" Length, 8" Dia., 8L18	8L18
24" Length, 8" Dia., 8L24	8L24
36" Length, 8" Dia., 8L36	8L36
48" Length, 8" Dia., 8L48	8L48
Adjustable Length 12", 8" Dia., 8LA	8LA
15° Elbow, 8" Dia., 8E15	8E15
30° Elbow, 8" Dia., 8E30	8E30
Rain Termination Cap, 8" Dia., 8CC	8CC
Wall Band, BM	BM
<b>Supports</b>	
Offset Support, SO	SO
Roof Support, ST	ST
Roof Brace, BS2	BS2
<b>Firestops</b>	
Telescopic Attic Radiation Shield, 8ARSA	8ARSA
Firestop, 8BF	8BF
Radiation Shield, 8RS	8RS
Insulated Attic Radiation Shield, 8RSA	8RSA2
Insulated Wall Radiation Shield, 8RSM	8RSM
<b>Roof Flashings</b>	
Flat Roof Flashing, 8FR	8FR
1/12 - 7/12 (5° - 30°), 8FAR	8FAR
8/12 - 12/12 (30° - 45°), 8FBR	8FBR
Storm Collar, 8FC	8FC

<b>AC Chimney</b> <i>(Air Cooled - 8" I.D., 13" O.D.)</i>	
Description	Cat./ Part No.
<b>AC Starter Adaptors</b> <i>An AC Adaptor is Need to Convert Fireplace for Use with AC Chimney</i>	
Starter Section (adaptor), 8" AC, AC8SB	H3801
Starter 30° Elbow, 8" AC, AC8SB30	H3802
<b>Outside Air Kit (Chimney)</b> <i>Required for AC Chimney Installations</i>	
Chimney Outside Air Kit (flex, insulation, outside register and coupling), ACZI	H1967
<b>Lengths and Misc. Chimney Components</b>	
18" Length, 8" Dia. x 18" Long, AC8L18	H3798
36" Length, 8" Dia. x 36" Long, AC8L36	H3799
48" Length, 8" Dia. x 48" Long, AC8L48	H3800
15° Elbow, 8" Dia., AC8E15	H3795
30° Elbow, 8" Dia., AC8E30	H3796
Rain Termination Cap, 8" Dia., AC8CPR	H3794
Spark Arrester Screen (universal spark arrester band) PE+	PE
Wall Band, XBM	XBM
<b>Supports</b>	
Offset Support, SO	XSO
Support Section, AC8SL	H3804
Roof Support, ST	XST
Roof Brace, BS2	XBS2
<b>Roof Flashings</b>	
Flat Roof Flashing, ACF	H0494
1/12 - 7/12 (5° - 30°), AC, Adj. Roof Flashing, FA	H0495
8/12 - 12/12 (30° - 45°), AC, Adj. Roof Flashing, FB	H0496
Storm Collar, ACFC	H0500
<b>Misc.</b>	
Telescopic Attic Radiation Shield, ACRST	H0498
Firestop, ACBF	H0485
Radiation Shield, ACRS	H0486
Attic Radiation Shield, ACRSA	H0487
Wall Radiation Shield, 30, AC, RSM30	ACRSM30
Insulated Wall Radiation Shield, 30, ACRSMI30	H0489
<b>Notes: AC Chimney is Not recommended at elevations above 4000 feet or in cold climates.</b>	

Fireplace		
Cat. No.	Model	Description
H7703	SOLANA-BK	Solana (w/Black Doors)
H7704	SOLANA-BN	Solana (w/Brushed Nickel Doors)

Specifications	
Weight	343 lbs
Height	42"
Width	43"
Depth	26-5/8"
Chimney Weight ASHT+ (8" dia)	8.75 lb/ft.
Chimney Weight S-2100+ (8" dia.)	13.2 lb/ft.
Chimney Weight AC (8" dia.)	3.75 lb/ft.

## CLEARANCE TO COMBUSTIBLES

The following clearances meet the minimum requirements for a safe installation;

**Side wall:** 18" (457 mm)

**Ceiling:** 7 feet (2135 mm) measured from the base of the fireplace

### Fireplace enclosure:

**Bottom:** 0"

**Side:** 0" to spacer

**Back:** 0" to spacer

**Top:** Do not fill the space above the fireplace with any material, 7 feet measured from the base of the fireplace (Except the wood framing). See **Page 11, Figure 9**.

**Chimney:** 2" (50 mm)

**Mantel:** 48" (1219 mm) measured from the base of the fireplace.

Mountain View Hearth Products  
manuals.stove-parts-unlimited.com

## REPLACEMENT PARTS LIST - SOLANA™

Item #	Description	Cat. No.
1	Refractory Baffle	PR-SR2028
2	Back Refractory	PR-SR2027
3	Right Side Refractory	PR-SR2025D
4	Left Side Refractory	PR-SR2025G
5	Bottom Refractory	PR-SR1722
6	Front Refractory Ash Lip	PR-SR2026
7	Log Support Grate	H7706
8	Top Louver	PR-SR15P
9	Bottom Louver	PR-SR15P
10	Louver Hinges	PR-PIVOT
11	Rigid Firescreen (Right)	PR-PARETIND-1
12	Rigid Firescreen (Left)	PR-PARETING-1
13	Black Door (Left)	H7708
14	Black Door (Right)	H7707
15	Brushed Nickel Plated Door (Left)	H7710
16	Brushed Nickel Plated Door (Right)	H7709
17	Wooden Handle	PR-SAC83
18	Touch-up Paint, Aerosol, Black Metallic SBMB6309	70K99

Item #	Description	Cat. No.
19	Ceramic Glass Panel	PR-VC10
---	Thermostatic Disc Control, Blower	VTU
20	Door Gasket, 31" <i>see note below</i> ❶	PR-COGR2035
21	Door Gasket, 16" <i>see note below</i> ❶	PR-COGR2035A
---	Horizontal Glass Gasket (for black doors)	PR-SR1685A
---	Vertical Glass Gasket (for black doors)	PR-SR1685B
---	Upper Glass Gasket (for nickel plated doors) ❷	PR-ISO2938
---	Side Glass Gasket (for nickel plated doors) ❷	PR-ISO2939
---	Lower Glass Gasket (for nickel plated doors) ❷	PR-ISO2750
22	Damper (plate, pivot, rod and counter-weight)	PR-SR2798

❶ *Note: To order the complete gasket set to seal one door, order 1 each P/N PR-COGR2035 (31") and 1 each P/N PR-COGR2035A (16").*

❷ *Note: To order a complete gasket set to seal one glass on a nickel plated door, order one each P/N PR-ISO2938 , P/N PR-ISO2939 and P/N PR-ISO2750.*

**Contact an Authorized Lennox Hearth Products dealer to obtain any of these parts. Never use substitute materials not approved by Lennox Hearth Products. Use of non-approved parts can result in poor performance and safety hazards.**

REPLACEMENT PARTS - SOLANA™

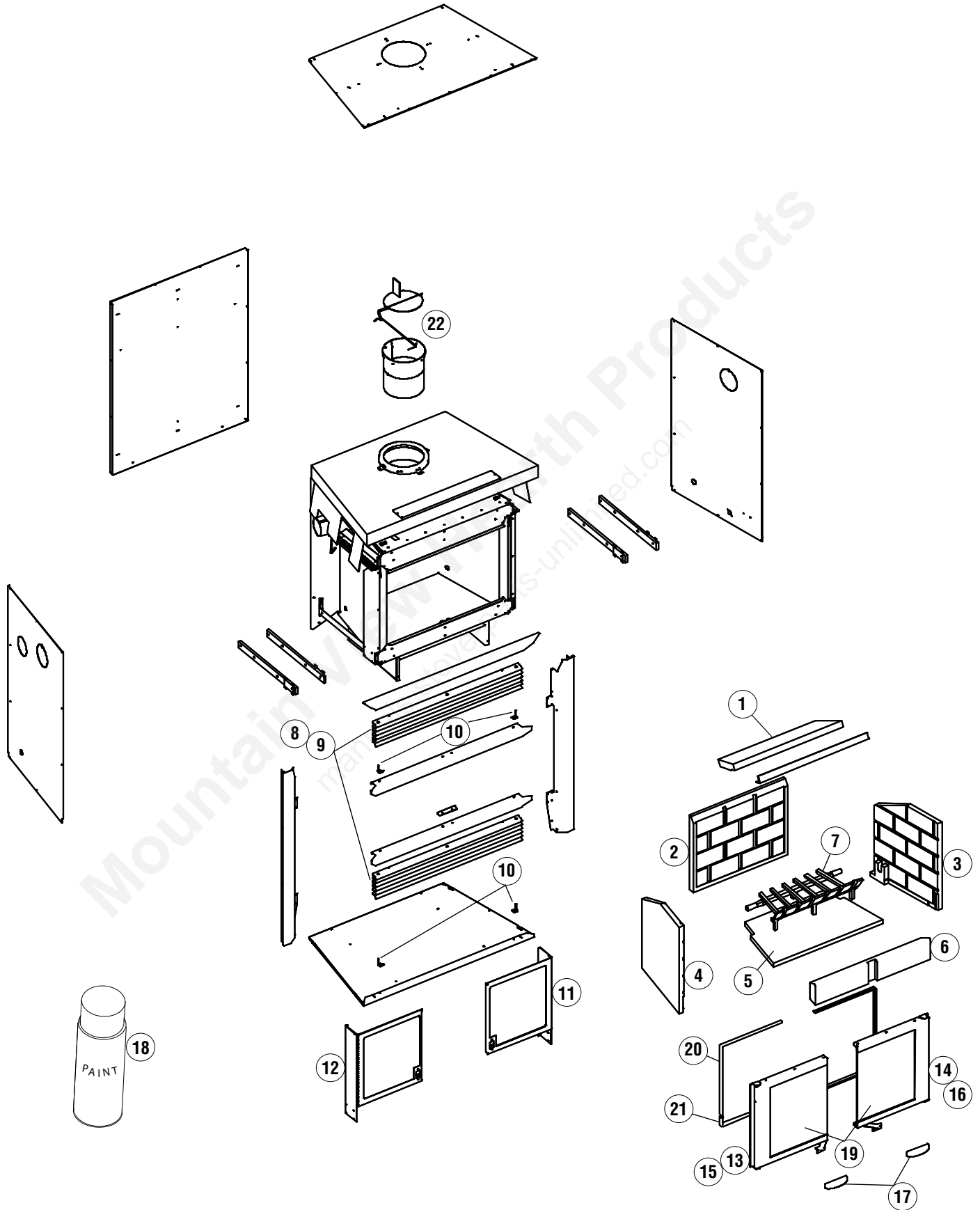

NOTE: DIAGRAMS & ILLUSTRATIONS ARE NOT TO SCALE.

## WARRANTY

Your fireplace is covered by a limited warranty. Please read the warranty to be familiar with its coverage.

Retain this manual. File it with your other documents for future reference.

## PRODUCT REFERENCE INFORMATION

We recommend that you record the following important information about your fireplace. Please contact your Lennox Hearth Products dealer for any questions or concerns. For the number of your nearest Lennox Hearth Products dealer, please call 1-800-9-LENNOX.

## REPLACEMENT PARTS

See **Pages 24 and 25** for a complete replacement parts list. Use only parts supplied from the manufacturer.

Normally, all parts should be ordered through your Lennox Hearth Products distributor or dealer. Parts will be shipped at prevailing prices at time of order.

When ordering repair parts, always give the following information:

1. The model number of the appliance \*
2. The serial number of the appliance \*
3. The part number
4. The description of the part
5. The quantity required
6. The installation date of the appliance

\* See listing/certification label located behind bottom louver on the left side of fireplace base.

If you encounter any problems or have any questions concerning the installation or application of this system, please contact your dealer.

## LENNOX HEARTH PRODUCTS

1508 Elm Hill Pike, suite 108  
Nashville, TN 37210  
Visit us at [www.Lennox.com](http://www.Lennox.com)

Your Fireplace's Model Number \_\_\_\_\_  
Your Fireplace's Serial Number \_\_\_\_\_  
The Date On Which Your Fireplace Was Installed \_\_\_\_\_  
Your Dealer's Name \_\_\_\_\_  
Your Dealer's Phone Number \_\_\_\_\_

**NATIONAL FIREPLACE INSTITUTE**  
**NFI**  
**CERTIFIED**  
[www.nficertified.org](http://www.nficertified.org)

We recommend that our woodburning hearth products be installed and serviced by professionals who are certified in the U.S. by the National Fireplace Institute® (NFI) as NFI Woodburning Specialists or who are certified in Canada by Wood Energy Technical Training (WETT).

  
Wood Energy  
Technical Training  
[www.wettinc.ca](http://www.wettinc.ca)

**NATIONAL FIREPLACE INSTITUTE**  
**NFI**  
**CERTIFIED**  
[www.nficertified.org](http://www.nficertified.org)

Nous recommandons que nos pœles à bois soient installés et que l'entretien soit effectué par des professionnels certifiés, aux Etats-Unis par le National Fireplace Institute® (NFI) et au Canada, par le Wood Energy Technical Training (WETT).

  
Wood Energy  
Technical Training  
[www.wettinc.ca](http://www.wettinc.ca)

Lennox Hearth Products reserves the right to make changes at any time, without notice, in design, materials, specifications, prices and also to discontinue colors, styles and products. Consult your local distributor for fireplace code information.

**LENNOX**  
**HEARTH PRODUCTS**