

INSTALLATION MANUAL

for the **MAJESTIC**®

MBC36A, MBC36AF, MBC36AM, MBC42, MBC42F
Heat Circulating Fireplace

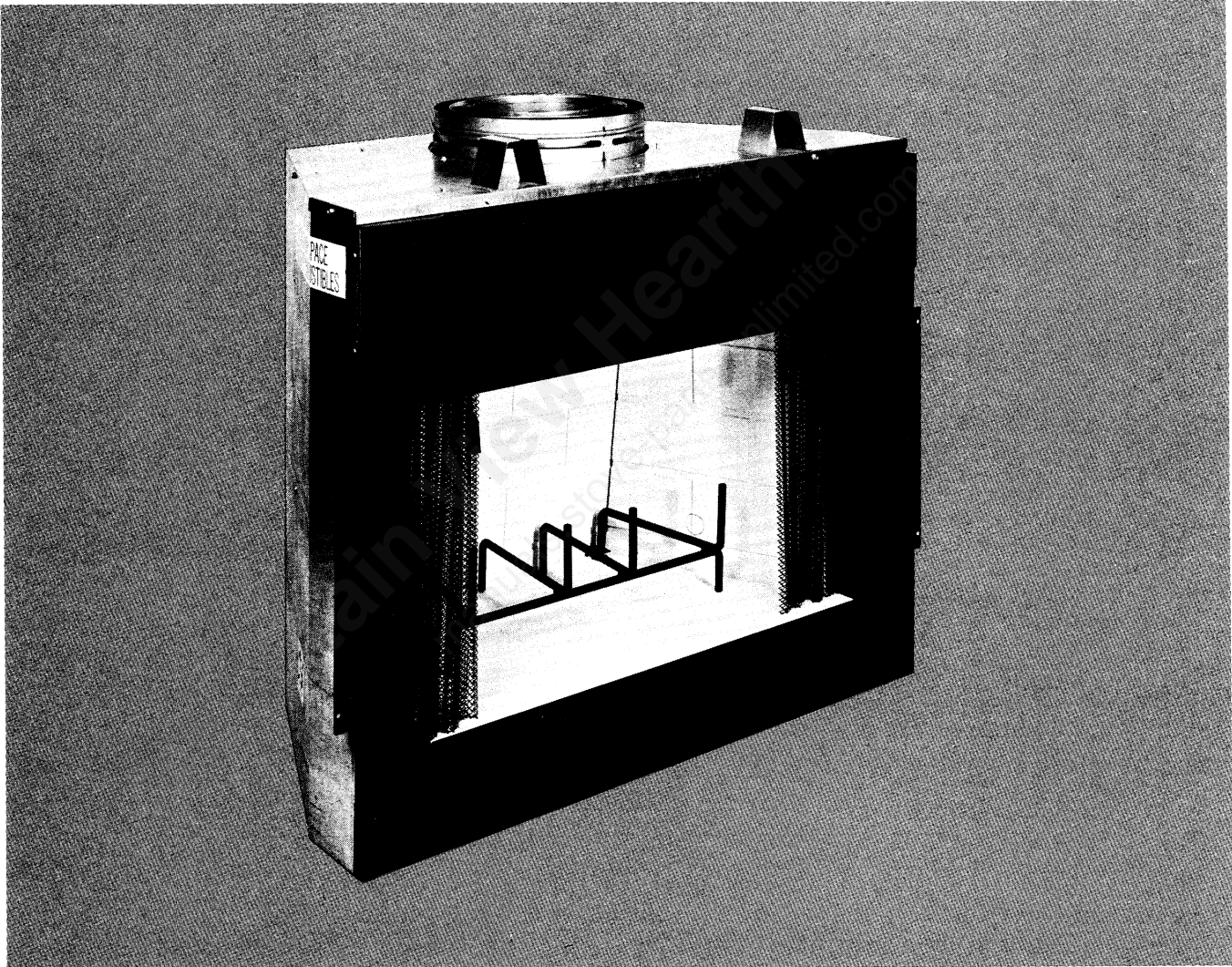

IMPORTANT: Read all instructions carefully before starting installation. Failure to follow these installation instructions may result in a possible fire hazard and will void the MAJESTIC warranty.

Save this manual for future reference.

MAJESTIC
An American-Standard Company

Copyright American Standard Inc. 1985

IDENTIFICATION OF PARTS

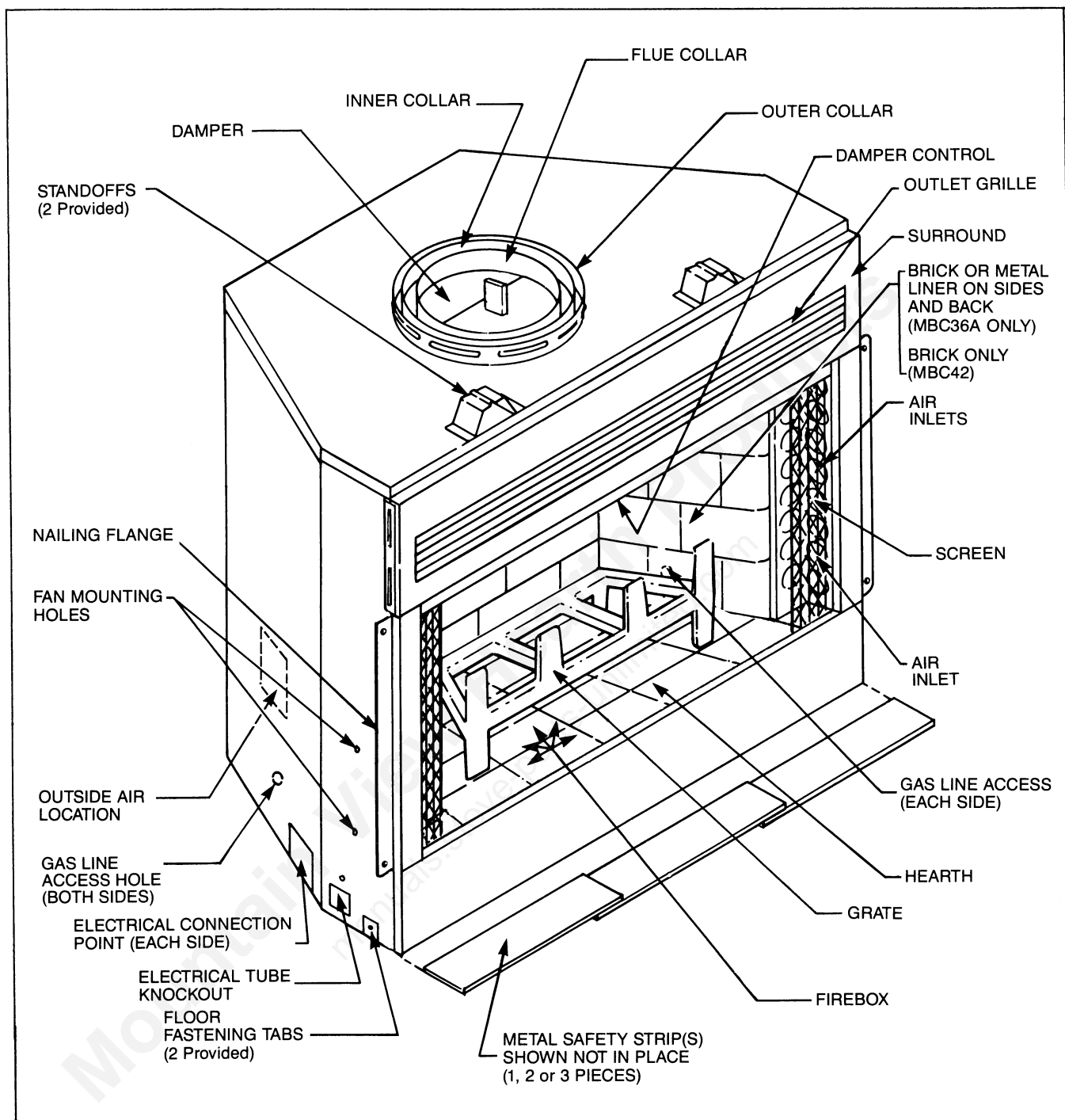

Fig. 1. Parts of the MAJESTIC MBC Series fireplace.

Table of Contents

	Page
Identification of Parts	2
Installation Precautions	3
Installation Instructions	3
Reference Data	14
Accessory Parts	15

INSTALLATION PRECAUTIONS

This MAJESTIC Fireplace and its components are tested and safe when installed in accordance with this Installation Manual. Read all instructions **before** starting installation, then follow these instructions carefully **during** installation to insure maximum fireplace benefit and safety.

Report to your dealer any parts damaged in shipment, specifically, check for loose insulation in the fireplace and damper operation.

Since this fireplace and chimney assembly is a highly engineered system, **unless** you use Majestic components* which have been designed for the system, you may possibly cause a fire hazard.

The MAJESTIC warranty will be voided by, and MAJESTIC disclaims any responsibility for, the following actions:

- Installation of any damaged fireplace or chimney component;
- modification of the fireplace, chimney assembly or any of the component parts thereof; (except for chase flashings as detailed in MAJESTIC Chimney Top installation instructions.)
- Installation other than as instructed by MAJESTIC; or
- Installation and/or use of any component part not manufactured or approved by MAJESTIC in combination or assembly with a MAJESTIC fireplace system, notwithstanding any independent testing laboratory or other third party approval of such component part or accessory.

Any such action may possibly cause a fire hazard.

Consult your local building codes.

This fireplace and chimney system must be vented out-of-doors.

Do not obstruct or modify air inlet/outlet grilles in any manner.

THE MBC36A MBC36AF, MBC36AM, MBC42, MBC42F ARE NOT APPROVED FOR INSTALLATION IN MOBILE HOMES.

CONTACT YOUR MAJESTIC DEALER FOR MOBILE HOME MODELS.

Prior to first firing, read Owner's Manual for operating instructions.

INSTALLATION INSTRUCTIONS

A. Installing the Fireplace

A-1. CHECK HOW ACCESSORIES ARE INSTALLED

Determine where selected accessories fit into this fireplace installation procedure by checking the installation instructions provided with each accessory. See *Accessory Parts*, page 15.

NOTE: The outside air system and electrical connection for the fireplace cannot be installed after the fireplace is completely installed.

A-2. DETERMINE FIREPLACE LOCATION

The fireplace can be mounted on any of the following surfaces: 1) A flat combustible (burnable) surface
2) A raised wooden platform
3) On four (4) corners of the fireplace. (Example: Four (4) concrete masonry blocks.)

These supports must be positioned so they contact the outer perimeter of the unit.

The fireplace may be placed against a combustible back wall without providing any clearance between the back spacer of the fireplace and the combustible material. Nearby combustible floors and walls must be protected as detailed in Section H.

Refer to *Air Space Data* and *Framing Data* on page 14 to be sure that the location which you have selected for your fireplace provides for clearance and framing restrictions.

At this point you should have decided what components to include in your installation, where the fireplace is to be located, and how the chimney will be routed to the roof (straight-up, offset, or chase*). If this has not been done, stop and consult your Majestic Dealer for assistance with this planning.

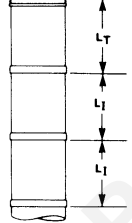

	CHIMNEY MODEL NO.		DIMENSIONS IN INCHES	
	DOUBLE WALL	TRIPLE WALL	TOTAL LENGTH (L _T)	INSTALLED LENGTH (L _I)
	CF81	81	11½	10½
	CF818	818	17½	16½
		82	23½	22½
	CF83	83	35½	34½
	CF84	84	47½	46½

Fig. 2. Installed lengths of chimney sections.

Note that the installed length of any chimney section is less than its total length (except for the last section installed), because of its overlap at joints. (See Fig. 2.)

*A chase is a vertical box-like structure which encloses the fireplace and/or its chimney, typically built on the outside of the house with the fireplace opening cut in the outer wall of the home.

A-3. INSTALL METAL SAFETY STRIPS UNDER FIREPLACE

Thoroughly clean intended fireplace location area. Move fireplace to the location where it is going to be installed. Lift fireplace front slightly to slide metal safety strip(s) under front bottom edge about 1½ inches, allowing the remainder to extend out in front of the fireplace. Overlap the strips at least ½ inch to provide a positive joint. (See Fig. 3.) (Safety strips are packed with fireplace.)

When positioning the fireplace on all mounting surfaces (see Step A-2), the metal safety strips must be installed as described above to provide protection to combustibles (burnable) surfaces in front of the fireplace.

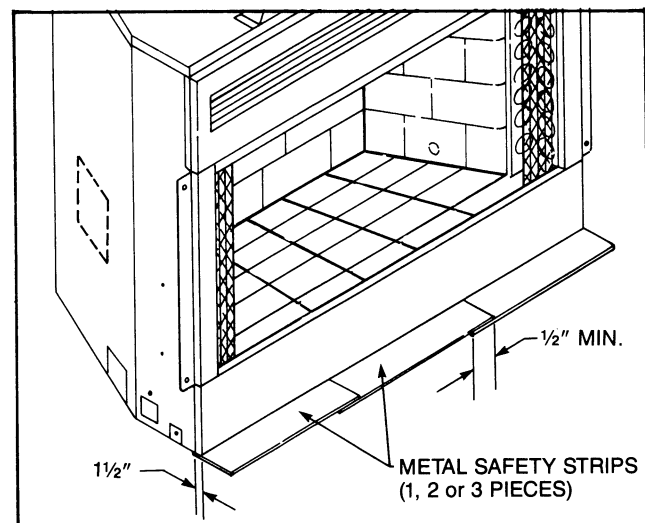

Fig. 3. Install metal strip(s) under front of fireplace.

□ A-4. ANCHOR FIREPLACE IN POSITION

To prevent shifting of the fireplace and to maintain sealing (described later), anchor the fireplace to the floor. Three methods are possible on the MBC Series. One method is to turn down the two fastening tabs located along the sides of the base pan and nail them to the floor. (See Fig. 4.) A second method for anchoring is to use the side nailing flanges provided on the fireplace. The fireplace can then be secured to the vertical framing members. Refer to Framing and Finishing Section H. The third method uses the standoff at the front of the fireplace. A nail may be installed through the standoff and into the header to stabilize the top of the fireplace. (Refer to Fig. 4.)

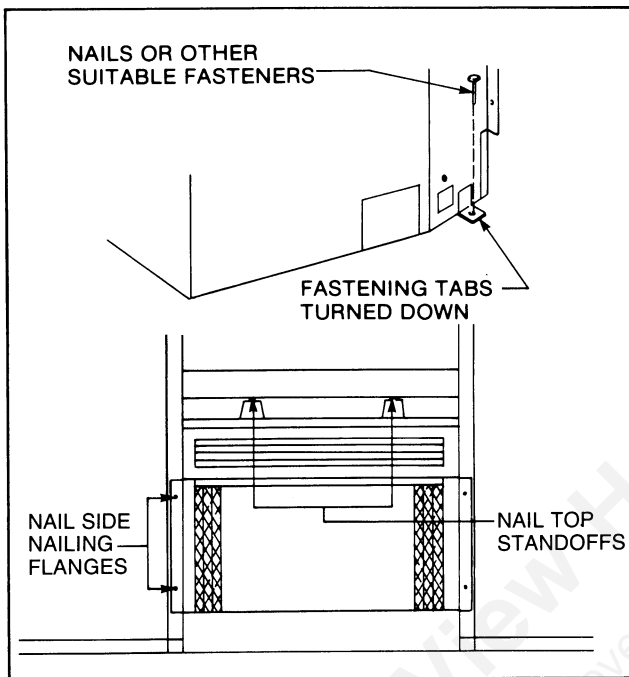

Fig. 4. Fasten fireplace in position using the fastening tabs or top standoff.

B. Installing the Chimney

CAUTION:
REPORT TO YOUR DEALER ANY PARTS DAMAGED IN SHIPMENT, SPECIFICALLY, CHECK THE END CONNECTIONS OF CHIMNEY SECTIONS AND ELBOWS.

NOTE: The MBC Series fireplace may use Majestic Model CF, 2 wall chimney components or Majestic Model S, 3 wall chimney system. The installation procedure described in Section B (Installing the Chimney), applies to both systems. Either system may be used, but 2 wall and 3 wall components may not be mixed. For clarification, refer to the Accessory Section of this manual beginning on page 15. Components from Section 1 are common to all installations. **Chimney components may be selected from Section 2 or Section 3, but may not be mixed.**

□ B-1. LOCATE CENTERPOINT OF CHIMNEY — STRAIGHT UP INSTALLATION

If the fireplace is positioned against the wall behind it, measure out 10 inches for the MBC36A or 11¼ inches for MBC42 from that wall and make a mark on the ceiling above the fireplace. Draw a line through this mark parallel to the back wall, defining the centerline of the chimney. (See Fig. 5.) Then, using a plumb bob positioned directly over the centerpoint of the fireplace

flue collar, mark the ceiling to establish the chimney centerpoint. (See Fig. 5.)

□ B-2. LOCATE CENTERPOINT OF CHIMNEY — OFFSET INSTALLATION

In order to clear an obstruction, it may be necessary to offset the chimney from the vertical plane. This is done by using MAJESTIC CHIMNEY ELBOWS: Models CF815 & 815 (15°) and CF830 & 830 (30°). Each offset requires a pair of elbows. Use Table 1 and Fig. 6 to determine the offset that may be obtained using the various elbows.

Table 1. Offset dimensions

	DIMENSIONS			
	T		S	
	CF815 or 815	CF830 or 830	CF815 or 815	CF830 or 830
No Intermediate Section	0'2½"	0'5"	1'4¾"	1'7½"
One 1' Section	0'5¼"	0'10¾"	2'2¾"	2'4½"
One 1½' Section	0'6¾"	1'1¼"	2'8¾"	2'9¾"
Two 1' Sections	0'7¾"	1'3⅝"	3'1"	3'1½"
One 1' and One 1½' Section	0'9½"	1'6½"	3'6¾"	3'6¾"
One 3' Section	0'11½"	1'10¼"	4'2"	4'1¼"
Two 1' and One 1½' Sections	1'0"	1'11⅞"	4'5"	4'3⅞"
One 4' Section	1'2"	2'3⅝"	5'¼"	4'10⅝"
One 3' and One 1½' Section	1'3¾"	2'6½"	5'6"	5'3½"
One 4' and One 1' Section	1'5"	2'9⅝"	5'11¾"	5'8¾"
One 1', One 3' and One 1½' Section	1'6¼"	2'11⅞"	6'4⅞"	6'⅝"
Two 3' Sections	1'8⅞"	3'3⅝"	6'11⅞"	6'7⅞"

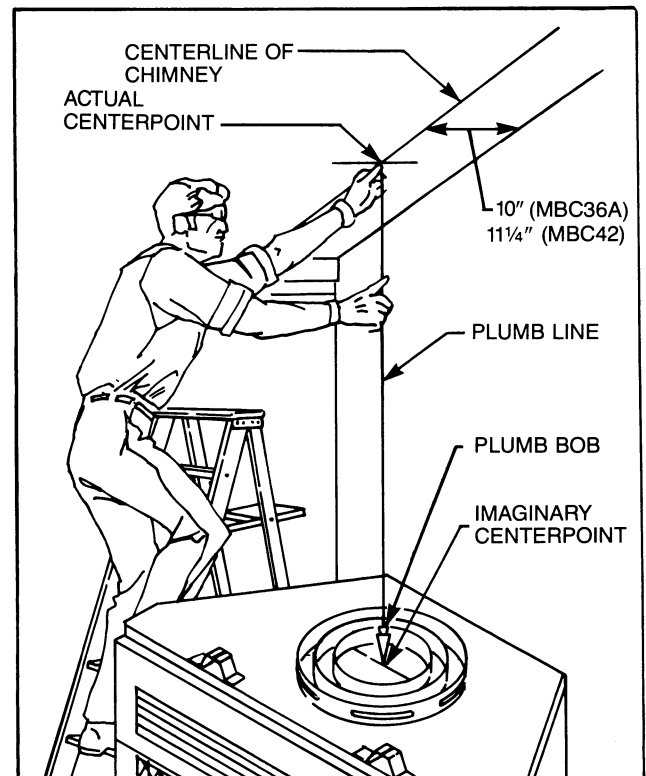

Fig. 5. Locate centerpoint of chimney with plumb line.

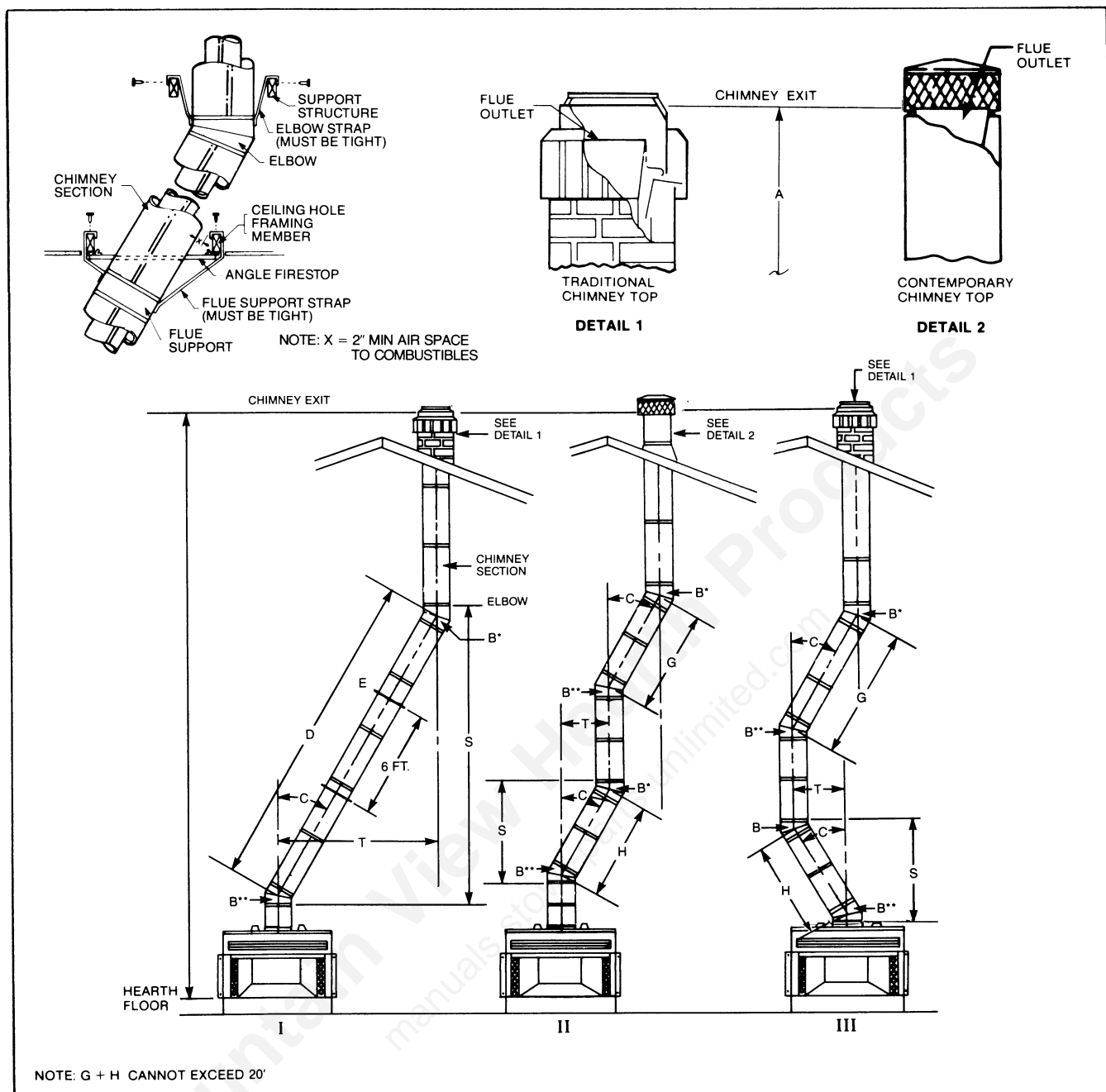

Fig. 6. Typical offset installations.

The following **safety rules** apply to offset installations. (The letters below match the letters in Fig. 6.)

A. Height of the chimney measured from the hearth to the chimney exit at top:

	MBC36A Series	MBC42 Series
Maximum:	90 Feet	90 Feet
Minimum:		
Without Elbows	12 Ft. 6 In.	14 Ft. 0 In.
With 2 Elbows	12 Ft. 6 In.	15 Ft. 6 In.
With 4 Elbows	16 Ft. 0 In.	21 Ft. 0 In.

B. Do not use more than four elbows per chimney. Attach the straps of the top elbows to a structural framing member. The first elbow of any pair does not have straps.

C. The chimney cannot be more than 30° from the vertical plane.

D. The maximum length of the angled run of the total chimney system is 20 feet. (G plus H cannot exceed 20 feet.)

E. A chimney support (Model TCS8) is required every 6 feet of angled run of chimney. Chimney supports are required at 30 feet and 60 feet of chimney height above the hearth also.

Determine the offset distance of your chimney arrangement from the centerline of the fireplace to the centerline of the chimney where it is to pass through the first ceiling. NOTE: This offset distance may not be your full offset distance (T).

Locate on the ceiling the centerpoint of the chimney, as though a straight up chimney arrangement is to be used, by following the procedure outlined in Step B-1. Then measure your offset dimension from the straight up chimney centerpoint on the ceiling. (Fig. 7.)

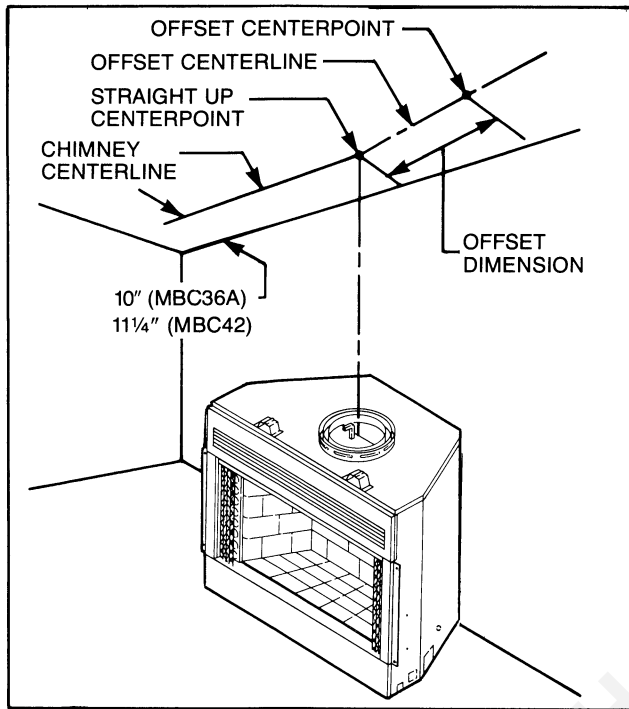

Fig. 7. Measure first ceiling offset distance from straight up centerpoint.

□ B-3. MARK AREA OF CEILING CHIMNEY HOLE

The size of the ceiling chimney hole will vary with the angle at which the chimney passes through the ceiling. Refer to Table 2.

Drive a nail up through the ceiling at the marked chimney centerpoint. Go to the floor above and check where the hole will be cut, relative to the ceiling joists and any obstructions such as wiring or plumbing runs. If necessary, re-position the chimney and/or the fireplace to better accommodate these joists and/or obstructions.

□ B-4. CUT CEILING CHIMNEY HOLE

After covering the opening of the fireplace collar, cut the chimney hole through the ceiling. Recheck the hole to be sure that it measures the hole size selected from Table 2.

□ B-5. FRAME CEILING CHIMNEY HOLE

Frame the ceiling chimney hole as shown in Fig. 8. It is good practice to use framing lumber that is the same size as the ceiling joists. (This is a requirement at the attic level.)

The **inside dimension** of the frame **must** be the same as the hole size selected from Table 2 in order to provide the required 2 inch air space between the outside diameter of the chimney and the edges of the framed ceiling hole.

Table 2. Sizes of ceiling chimney hole.

Size of Chimney	Angle of chimney at ceiling		
	Vertical	15°	30°
8" Flue	17½ x 17½	17⅞ x 22½	17⅞ x 29⅝

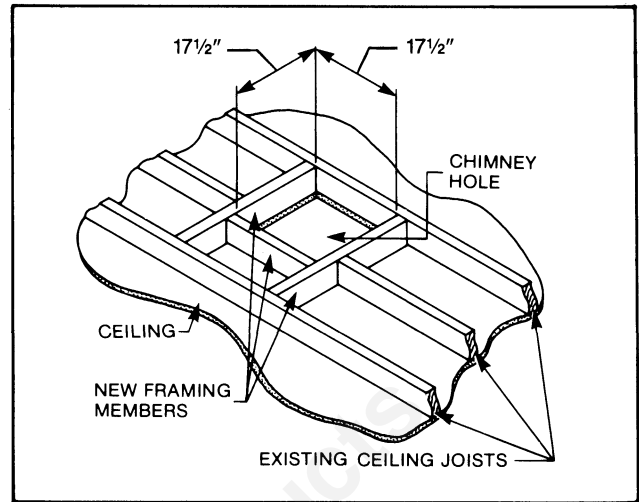

Fig. 8. Typical frame for ceiling chimney hole.

□ B-6. INSTALL FIRESTOP SPACER

Firestop spacers are required for safety. The hole sizes listed in Table 2 for angled firestop spacers provide the minimum required air space to the chimney pipe for ceiling thicknesses up to 8 inches. When the combined thickness of the ceiling material, ceiling joists and flooring material exceeds 8 inches, adjustments must be made in the framing to assure that the minimum air spaces to the chimney are maintained.

If the area above the ceiling is **not** an attic, position the firestop spacer with the flange on the ceiling side and the dished or angled portion extending up into the hole. If the area above the ceiling is an attic, position the firestop spacer with the flange on the top of the framed hole and the dished or angled portion extending down into the hole. (See Figs. 9 & 10.)

Nail each corner of the firestop spacer to the framing members of the ceiling hole. **NOTE:** A firestop spacer is not required at the roof.

Table 3. Firestop model numbers.

TYPE FLUE	TYPE OF SPACER	MODEL NO.
8" straight	Dished	FS2A
8" 15° inclined	Angled	FS9A
8" 30° inclined	Angled	FS6A

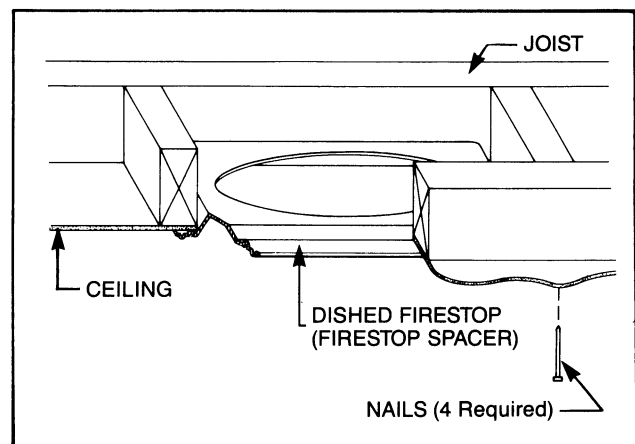

Fig. 9. Position of firestop when area above ceiling is not an attic

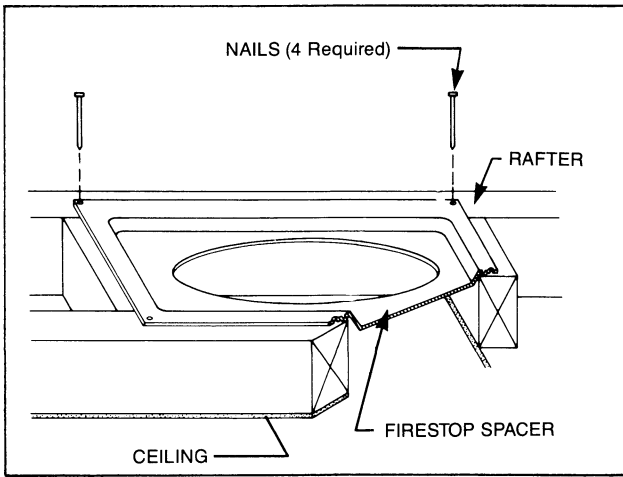

Fig. 10. Position of firestop when area above ceiling is an attic.

□ B-7. ATTACH CHIMNEY SECTIONS

Attach the first straight chimney section to the fireplace collar, or elbow if offset installation. (Refer to Step B-8.) Mount the flue pipe first, using the built-in snap-lock fasteners. (See Fig. 11.) Then mount the additional pipe(s). Position each pipe section so the direction arrow is pointing UP.

Make sure each pipe is firmly snapped and locked together as it is mounted.

Continue installing chimney sections until ONE SECTION (all pipes) extends up through the ceiling hole. To extend through the ceiling, it may be necessary to assemble all pipes, push them up through the ceiling hole and then slide them down one at a time to connect them.

□ B-8. ATTACH FIRST ELBOW — OFFSET INSTALLATION

If the first elbow is not to be attached to the fireplace, install chimney sections as required.

Attach first elbow where required. Note that only the outer pipe snap-locks.

Attach the straps of all upper elbows to a structural framing member. (See Fig. 12.)

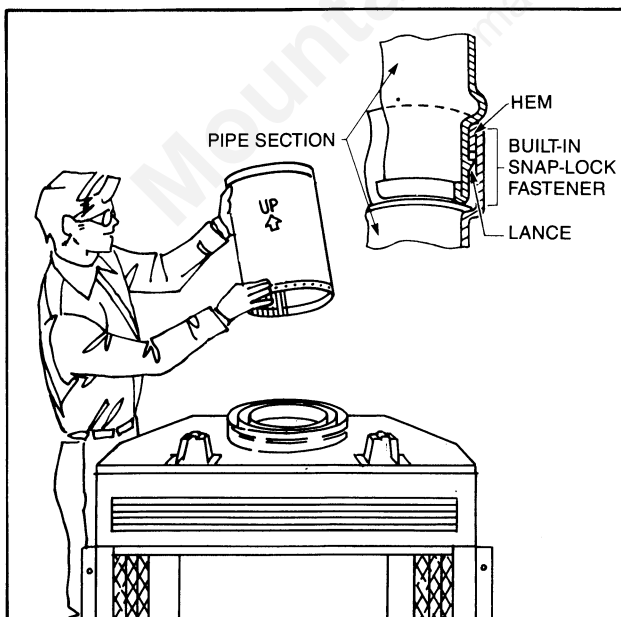

Fig. 11. Use built-in snap-lock fasteners to attach chimney pipe sections.

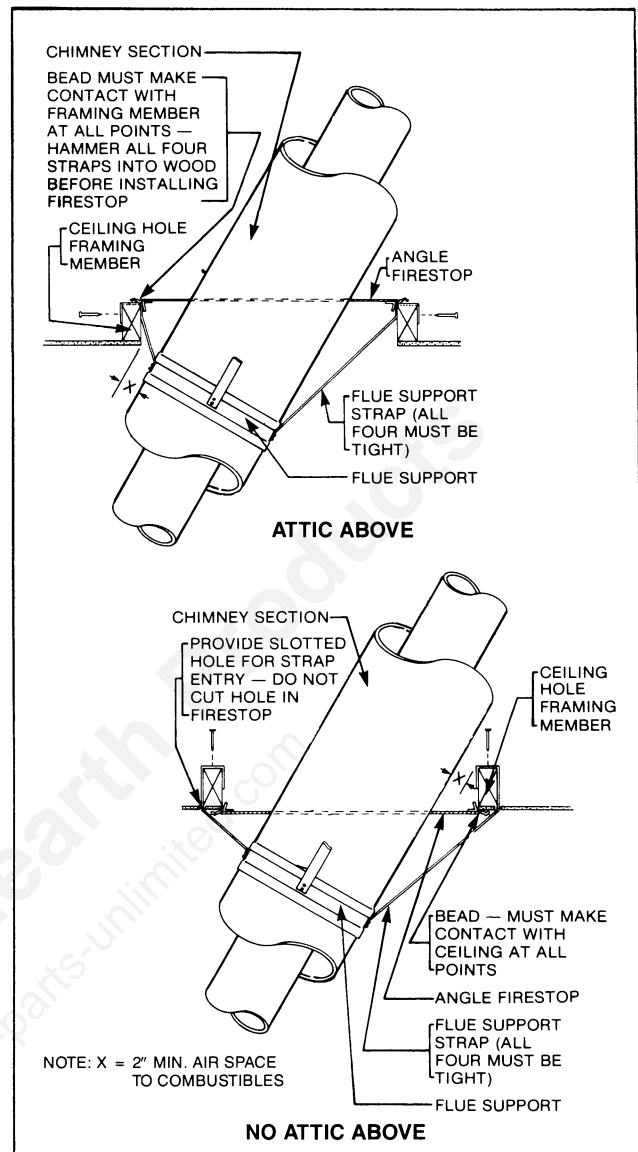

Fig. 12. Mount flue supports at ceiling hole frames or other structural framing.

□ B-9. DETERMINE HOW MANY CHIMNEY SUPPORTS ARE NEEDED

The chimney system is supported by the fireplace for chimney heights less than 30 feet of vertical height above the hearth. Chimney supports are required if the chimney height exceeds 30 feet. Locate chimney supports at ceiling holes or other structural framing at 30 foot heights. Spacing between chimney supports must not exceed 30 feet. Use MAJESTIC Chimney Support Model TCS8. **(NOTE: The TCS8 can not be mounted directly to the fireplace.)** Support provided by elbow straps fulfills the support requirement only if they are spaced as required above.

Angled chimney runs require support every 6 feet in addition to the elbow straps. MAJESTIC Chimney Supports are used for this function.

Refer to Step B-2 to determine how many chimney supports are needed and where they will be placed in the chimney run.

NOTE: A chimney support is 3 inches long when installed. This dimension must be considered when determining how many straight chimney sections are needed to provide the desired offset.

B-10. INSTALL CHIMNEY SUPPORTS

Chimney supports are attached to chimney sections the same way elbows are attached. Refer to Step B-8. Nail the chimney support straps to adjacent structural framing, as shown in Fig. 12. Bend the straps as necessary and make sure they are tight so they will be able to support the weight of the chimney.

B-11. LOCATE CENTERPOINT OF NEXT CEILING HOLE

NOTE: If there is no other ceiling, you have completed Section B. Turn now to Section C, *Penetrating the Roof*.

In a manner similar to that used in Steps B-1 and B-2, mark the centerpoint of the next ceiling hole.

B-12. PREPARE SECOND CEILING HOLE

Repeat Steps B-3. Mark area of ceiling chimney hole; B-4, Cut ceiling chimney hole; B-5, Frame ceiling chimney hole; and B-6, Install firestop spacer.

B-13. CONTINUE INSTALLING CHIMNEY SECTIONS

Continue installing chimney sections and chimney supports (as required), until the chimney passes through the second ceiling hole.

NOTE: Repeat Steps B-11 through B-13 as many times as necessary to pass through all the ceilings in the building and bring the chimney just short of the roof.

C. Penetrating the Roof

The chimney system must be vented out-of-doors and must be terminated in an approved MAJESTIC top termination.

NOTE: If you are using a chase, go to Section D.

C-1. LOCATE CHIMNEY CENTERPOINT AT ROOF

Use the same procedure detailed in Steps B-1 and B-2.

Drive a nail up through the roof at the marked centerpoint. This will mark the centerpoint on the outside of the roof.

C-2. CUT AND FRAME ROOF HOLE

The size of the roof hole varies with the type of chimney top that will be installed. Refer to the installation instructions provided with your MAJESTIC chimney top termination to find the correct size of roof hole for this installation. There must be at least 2 inch air space between the outermost portion of the chimney sections and any adjacent combustible (burnable) surfaces.

WARNING: DO NOT PACK REQUIRED AIR SPACES WITH INSULATION OR OTHER MATERIALS.

(Combustible surfaces include such things as ceiling members, joists, flooring, combustible insulation and roof structures.)

Mark the outline of the roof hole around the centerpoint nail. **Note:** The hole dimensions given in the chimney top installation instructions are **horizontal** dimensions; therefore, the hole size must be marked on the roof accordingly.

Cover the opening of the installed chimney.

Cut and frame the hole. It is good practice to use framing lumber that is the same size as the rafters. **Install frame securely. Chimney top and flashing anchored to frame must withstand heavy winds.**

C-3. DETERMINE MINIMUM CHIMNEY HEIGHT ABOVE ROOF

Major U.S. building codes specify minimum chimney height above the roof top. These specifications are summarized in the *Ten Foot Rule*. (See Fig. 13.) The key points of this rule are:

1. If the horizontal distance from the center of the chimney to the peak of the roof is 10 feet or less, the top of the chimney must be at least 2 feet above the peak of the roof, but never less than 3 feet in height above the highest point where it passes through the roof.
2. If a horizontal distance from the center of the chimney to the peak of the roof is more than 10 feet, a chimney height reference point is established that is on the surface of the roof a distance of 10 feet from the center of the chimney in a horizontal plane. (See Fig. 13.) The top of the chimney must be at least 2 feet above this reference point, but never less than 3 feet in height above the highest point where it passes through the roof.

These chimney heights are necessary in the interest of safety and do not assure a smoke-free operation.

C-4. INSTALL REMAINDER OF CHIMNEY SECTIONS

Continue installing chimney sections up through the roof hole. Check your chimney top installation instructions for data on how high above the roof top the CHIMNEY SECTIONS (all pipes) should go.

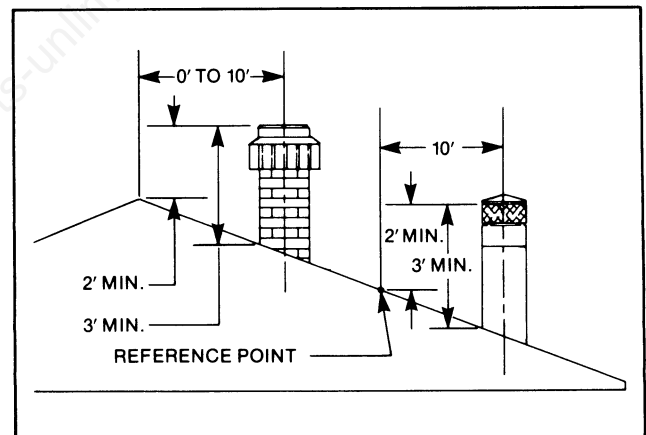

Fig. 13. Ten foot rule for chimney height.

C-5. INSTALL CHIMNEY TOP HOUSING OR TERMINATION

Follow the installation instructions provided with the MAJESTIC chimney top you have selected.

D. Installing Chimney in a Chase

A chase is a vertical box-like structure built to enclose the fireplace and/or its chimney.

CAUTION: Treatment of firestop spacers and construction of the chase may vary with the type of building. These instructions are not substitutes for the requirements of local building codes. Therefore, your local building codes must be checked to determine the requirements for these steps.

NOTE: Other material may be required in addition to MAJESTIC Firestop Spacers.

When installing an MBC Series fireplace and chimney in a chase, it is always good building practice to **insulate the chimney chase as you would an outside wall of your home**. See Section G, which describes insulation methods.

Refer to *Framing and Finishing* on page 11. Upon completion of building your chase frame, install the chimney system. Follow the instructions for *Installing the Chimney* starting on page 4. Then proceed to Step D-1.

D-1. INSTALL FLASHING AND CHIMNEY TOP

Follow the installation instructions provided with the MAJESTIC chimney top you have selected.

E. Install the Electrical Connection (MBC36AF and MBC42F ONLY)

E-1. ELECTRICAL CONNECTION

The MBC36AF and MBC42F fireplaces have factory installed fans requiring electrical connection at the time of installation.

CAUTION: All wiring should be done by a qualified electrician and shall be in compliance with all local, city and state building codes.

E-2. MBC36AF & MBC42F ELECTRICAL POWER.

The fans require 120 VAC, 60 Hz power available at the left side of the fireplace. The power should be available to the fireplace through a single Listed 15 AMP, 125 V wall switch. (Switch not provided.)

E-3. INSTALLATION OF FIELD WIRING

A junction box is provided with the fireplace. Mount the junction box by first removing the electrical box knockout on the left side of the fireplace, and then sliding the J box into place and securing with a #8 screw provided. (See Fig. 14.) Remove the outer cover plate from the box.

Next, route the field supplied wiring from the switch box to the junction box in accordance with local electrical codes. Be sure wiring does not contact outer fireplace surfaces and support wiring in a manner that will assure clearance from the fireplace components.

Insert 120 V, 60 Hz power lines through either knockout in the back or side of the junction box. The ground wire from the power should be attached to the ground stud in the top of the junction box with one of the supplied retaining nuts.

Using the supplied wire nuts, connect the ends of the white and black power leads to the fireplace leads (See Wiring Diagram, Fig. 15), making sure the wire nuts are tight to the leads. All black leads should be connected together and all white leads should be connected together.

E-4. SERVICING FANS AFTER INSTALLATION

For servicing fans after installation, access is gained by removing the perforated front corner panels with the 1½" diameter holes. The glass enclosure **must** be removed first if installed. (Refer to the glass enclosure Instruction Manual for removal procedure.) To remove the corner panel, first remove the two screen retaining clips from the left side and slide screen to center of fireplace opening. Next, using the Phillips head screwdriver, remove the six (6) screws retaining the left perforated corner panel. Grasp the corner panel through the perforated holes and set back into the wall cavity, making sure that the screen rod slips out of the small hole in the top of the panel. Then tilt top of corner panel out through cavity opening

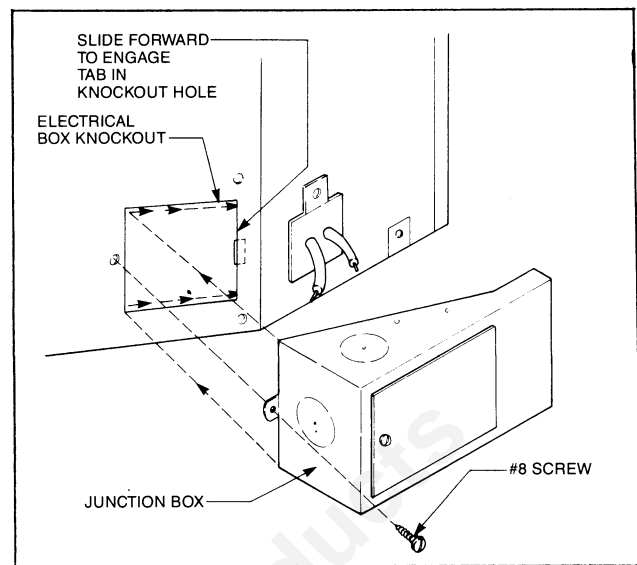

Fig. 14. Wiring box being mounted.

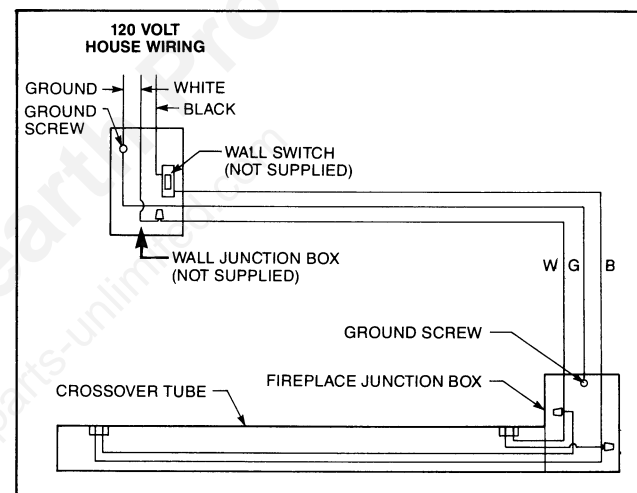

Fig. 15. Wiring diagram.

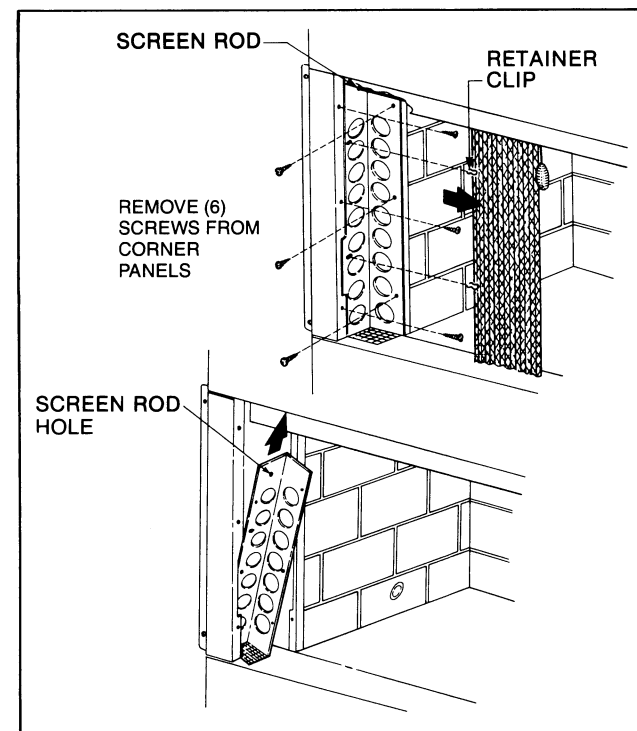

Fig. 16.

and withdraw entirely, allowing access to fan and wiring box. The wiring box cover may then be removed. If only the fan needs service, the fan plug may be disconnected and screws removed that retain the fan. Reinstall all components in the reverse order of removal. (See Fig. 16.)

F. Installing Optional Outside Air Kit and Fan Kit

Later addition of outside air and fans (without preinstalled Wiring Kit) will require significant reconstruction. These accessories should be installed at the time of original installation of the fireplace.

□ F-1. INSTALL OUTSIDE AIR KIT

Install outside air kit if desired or required by local code. Refer to MBA-36A (MBC36A Series) or MBA-42 (MBC42 Series) installation instructions supplied with the appropriate kit.

□ F-2. INSTALL FAN KIT

Refer to the MFK Fan Kit and SWK or SWK42; DWK or DWK42 Wiring Kit Instructions for field installation of fans. The SWK type Wiring Kit provides one junction box with internal "crossover" wiring tube for single side wiring. This kit must be installed before framing is installed. The DWK type provides two wiring boxes. With the DWK, field wiring must be provided to both sides of the fireplace.

G. Insulating Fireplace Enclosure For Cold Climates

In cold climates, insulation of the enclosure around the fireplace is critical to avoid future problems with cold air. The following steps are suggested to eliminate potential cold air problems.

□ G-1. INSULATE BASE OF FIREPLACE

Insulate the base of the fireplace with a non-combustible insulation rated for a minimum of 300°F. This step is particularly important for outside wall installations over concrete slab floor construction. If a platform is used to raise the fireplace, the insulation should be placed on top of the platform before the fireplace is set. (See Fig. 17.)

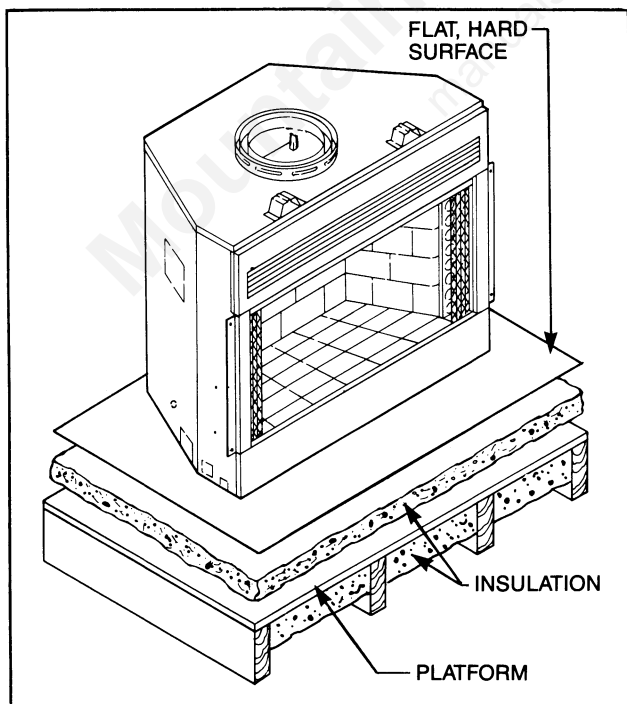

Fig. 17. Insulation between platform and fireplace.

□ G-2. INSPECT JOINTS

Inspect joints of the fireplace as well as the points of sealing between the fireplace and the finishing materials. Any cracks should be sealed with non-combustible caulking or insulation. See Fig. 18 for details of sealing spaces between the fireplace and finishing materials.

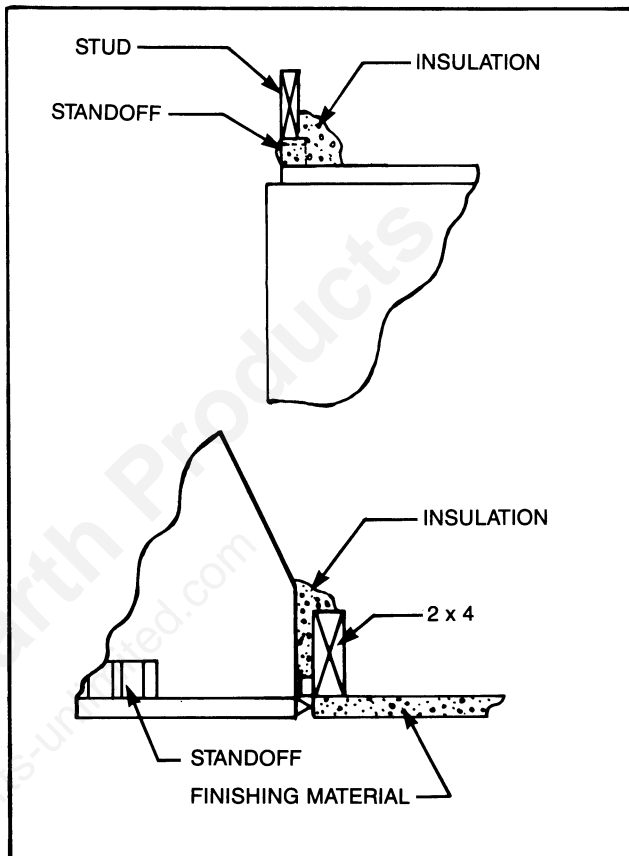

Fig. 18. Sealing spaces between fireplace and finishing materials.

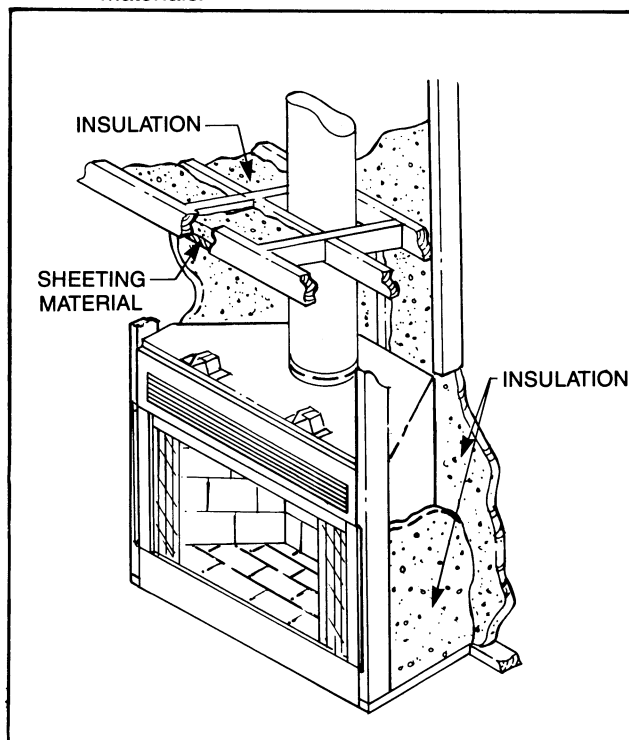

Fig. 19. Additional insulating methods.

□ G-3. INSULATION OF ENCLOSURE

When a fireplace is installed in a chase or on an outside wall, the enclosure should be insulated like any other wall of the home. Insulation should be installed on the inside wall as well as the outside wall(s). In a chase, it is also a good idea to install a firestop at the first ceiling level above the fireplace and close the chase with sheeting material. Insulation may then be installed above the sheeting material to assure the space around the fireplace is totally protected. See Fig. 19 for additional details of suggested insulating methods.

CAUTION: WHILE INSTALLING A FIREPLACE IN AN INSULATED ENCLOSURE, BE SURE ALL MARKED AIR SPACES ARE MAINTAINED.

H. Framing and Finishing

□ H-1. DETERMINE WHEN TO INSTALL FRAMING

Fireplace framing can be built before or after the fireplace is set in place. Fig. 20 shows the minimum framing dimensions.

□ H-2. BUILD FRAMING

The fireplace framing should be constructed of 2 x 4 lumber or heavier. Refer to *Framing Data* on page 14 for basic fireplace dimension that will affect the framing dimensions.

The header may rest on the fireplace standoffs.

Framing should be positioned to accommodate wall covering and fireplace facing material. (See Figs. 26 and 27 for typical arrangements.) Nailing flanges provided on the sides of the fireplace can be used to position the fireplace for a 5/8" finished wall covering, as well as anchor the fireplace. Nail through the flanges into the vertical framing members. (See Fig. 20.)

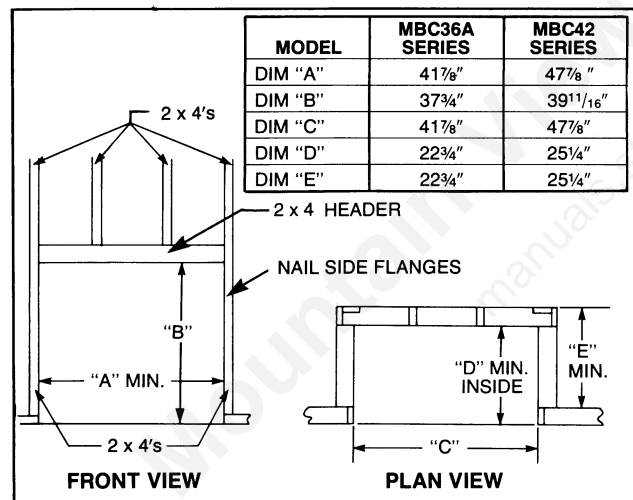

Fig. 20. Minimum fireplace enclosure dimensions.

CAUTION: All joints between the finished wall and the fireplace surround (top and sides) must be sealed with non-combustible material. Only non-combustible material may be applied as facing to the fireplace surround.

□ H-3. FINISH WALL

Finish the wall with material of your choice. Do not install a combustible mantle or other combustible projection less than 15 inches (MBC36 Series) or 18 inches (MBC42 Series) above the outlet grille. If a combustible material is used, consult your local building codes for the minimum clearance from the top of the fireplace opening to the bottom of the mantel.

All joints (top, bottom and sides), where the wall or decorative facing material meets the fireplace surround

must be completely sealed with a non-combustible material. (See Figs. 21, 22 and 23.)

When finishing the fireplace, never obstruct or modify the air inlet/outlet grilles in any manner.

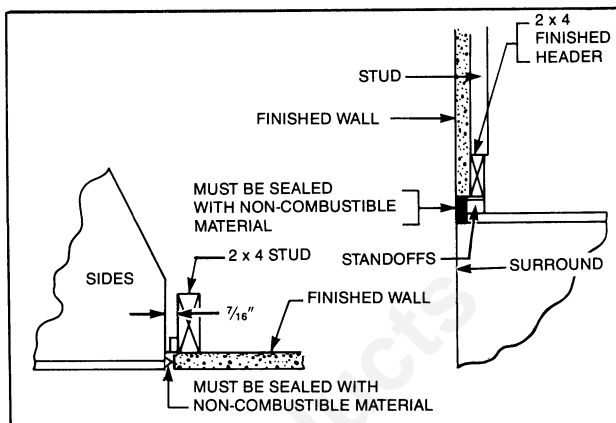

Fig. 21. Fireplace surround flush with finished wall.

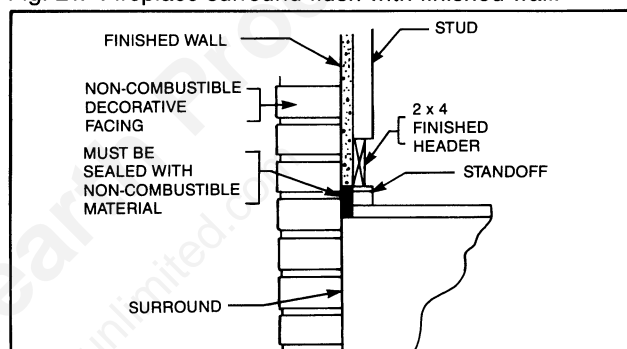

Fig. 22. Fireplace surround flush with finished wall.

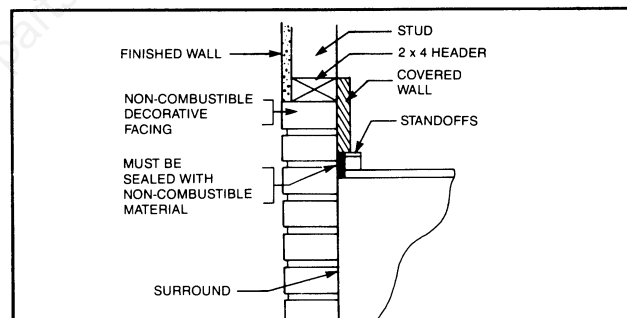

Fig. 23. Facing on fireplace surround flush with finished wall.

□ H-4. ADD PROTECTION TO SIDE WALLS

Adjacent combustible side walls that are within 21 1/2" (MBC36A) or 28" (MBC42) of the fireplace openings must be protected with MAJESTIC Wall Shield Model SP40 or Majestic Specification 74-10-102A or a built up wall shield described in Fig. 24. (See Figs. 24 & 25).

The built-up wall shield design described in Fig. 24 is an alternate method for adding protection to side walls and can be used in place of the SP40 with the same wall clearances specified for the SP40.

EXAMPLES OF INSULATIONS:

1. Johns Manville — CERAFORM 126, K = .27, 1/2" required.
2. U.S. Gypsum Corp. — MICORE CV230, K = .54, 1" required.

Contact the Majestic Company, Huntington, Indiana, 46750. Attention: Director of Customer Service to obtain Specification 74-10-102A.

NOTE: For fireplaces installed at 45 degrees to two sidewalls (corner installations), no sidewall protection is required.

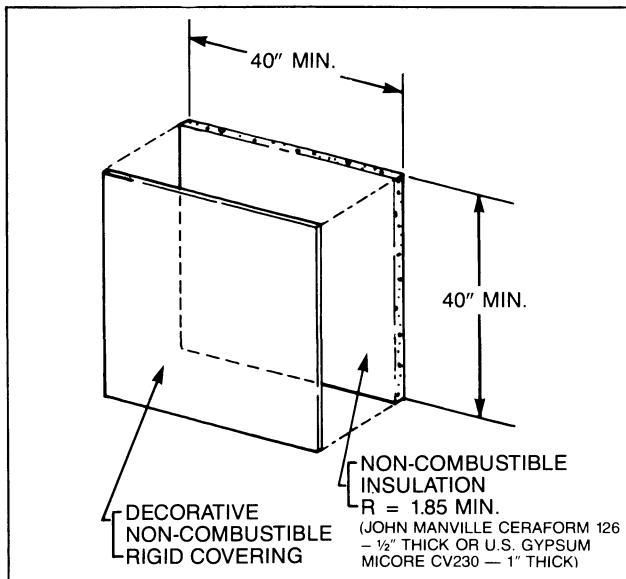

Fig. 24. Non-combustible wall shield dimensions.

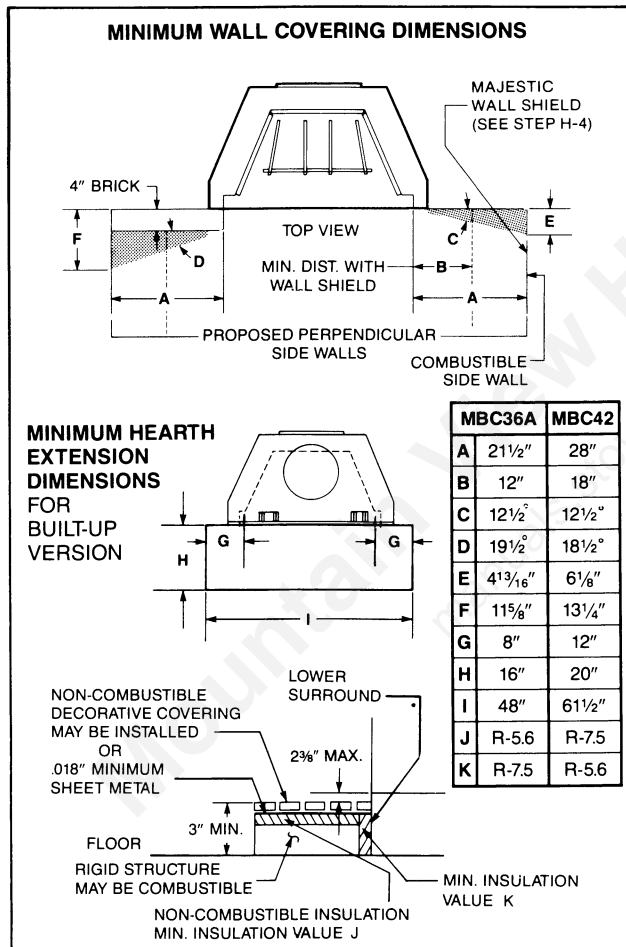

Fig. 25. Protection of adjacent combustible side walls and hearth extension dimensions.

□ H-5. INSTALL HEARTH EXTENSION

A hearth extension is required to protect combustible floor construction in front of the fireplace, and it must be a MAJESTIC Hearth Extension Model EH36A for MBC36A Series or EH42A for MBC42 Series, or a design built in accordance with Figs. 25, 26, 27, & 27A or Majestic Specification 74-10-102A.

The built-up hearth extension described in Fig. 25 must be a rigid structure at least 3 inches in overall height (above combustible floor) depth and width as indicated,

and centered to the fireplace opening.

The top portion of the extended hearth and rear surface in contact with the lower fireplace surround must be made of non-combustible, rigid insulation with a minimum R value as indicated in Fig. 25. The top insulation must be covered with a piece of .018 minimum sheet metal or other non-combustible decorative covering.

EXAMPLES OF INSULATION:

1. Johns Manville — CERA FORM 126, 1½" Top and 2" Rear required.
2. U.S. Gypsum Corp. — MICORE CV230, 2½" Top and 3¼" Rear required.

Secure the hearth extension to the floor to prevent shifting, using trim molding or other similar means at the three outer edges. Seal the crack between the fireplace hearth and the hearth extension with non-combustible material (See Figs. 26, 27, and 27A).

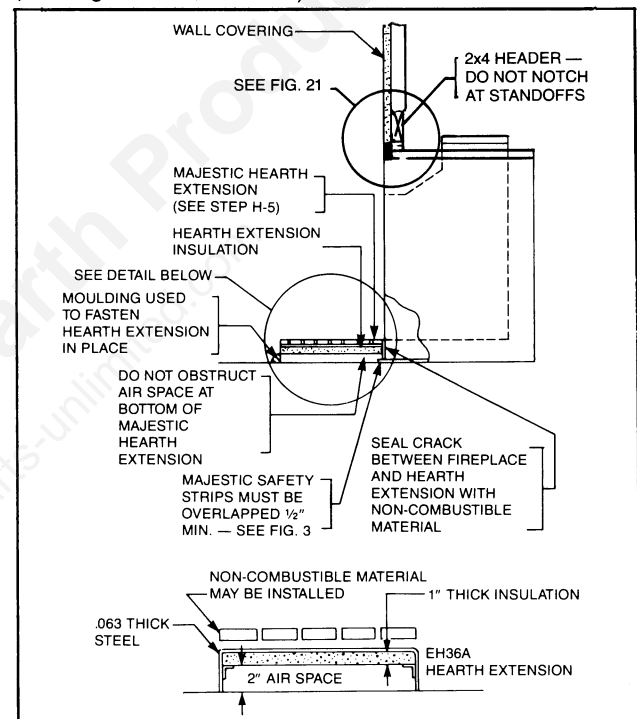

Fig. 26. Sealing detail.

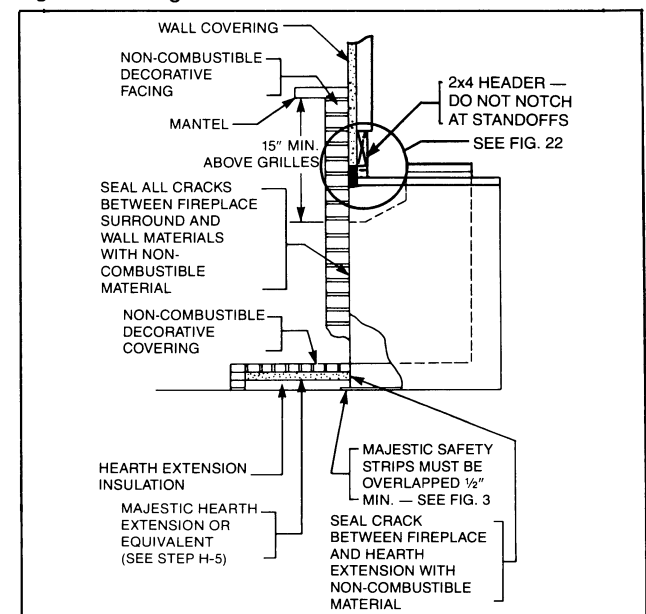

Fig. 27. Sealing detail.

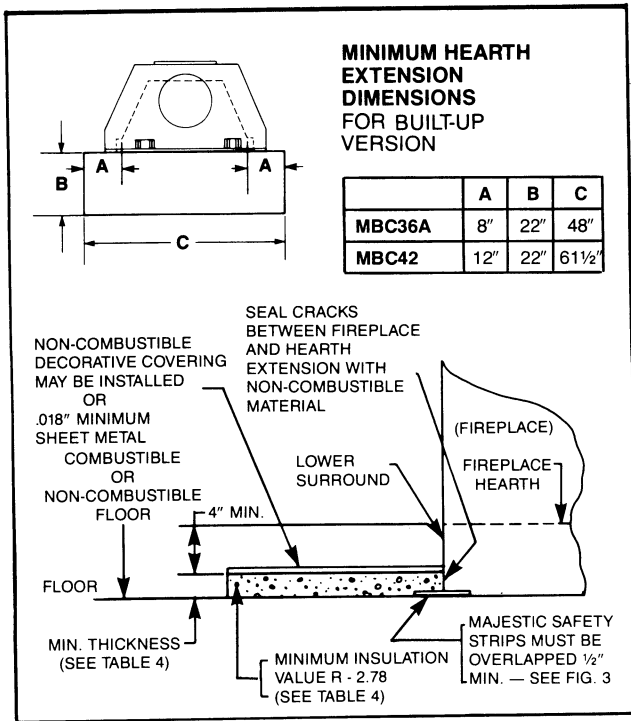

Fig. 27A. Hearth extension dimensions.

The hearth extension described in Figure 27A must be constructed of an insulation with a minimum R value of 1.85 for MBC36A and 2.78 for MBC42. See Table 4 below.

TABLE 4: EXAMPLES OF INSULATION

Type of Insulation	Minimum Thickness Required	
	MBC36A	MBC42
Johns Manville CERAFORM 126	½-inch	¾-inch
U.S. Gypsum Corp. MICORE CV230	1-inch	1¼-inch

WARNING:
HEARTH EXTENSION MUST BE INSTALLED IN ACCORDANCE WITH FIGS. 25, 26, 27, OR 27A.

□ H-6. INSTALL DECORATIVE GAS APPLIANCE

The Majestic MBC Series fireplace is designed to accept a ½ inch gas line for an approved gas appliance. Have the appliance installed by a qualified plumber in accordance with all building codes. The gas connection may enter from either side of the fireplace. The following instructions apply to the side selected.

Locate the gas line hole in the outer casing of the fireplace and remove the insulation from the gas line tube. (Refer to Fig. 28).

Next, insert a ½ inch gas pipe through the gas line tube from the outside of the fireplace and forcibly punch out the ceramic or metal knockout on the inside of fireplace. Now, install the ½ inch gas pipe through the opening. After the gas pipe installation is complete, use the insulation that was removed from the gas line tube to repack the space around the pipe. This should be inserted from the outside of the fireplace and packed tightly to totally seal between the pipe and the tube.

NOTE: The gas pipe should not come in contact with any wood structures until it has reached a point at least one (1) inch away from the fireplace side. (See Fig. 28 for installation clarification.)

The gas pipe installation is intended for connection to a decorative gas appliance only, in accordance with the National Fuel Gas Code, ANSI Z223.1-1980.

CAUTION: WHEN USING DECORATIVE GAS APPLIANCE, THE FLUE DAMPER MUST BE SET IN THE FULLY OPEN POSITION.

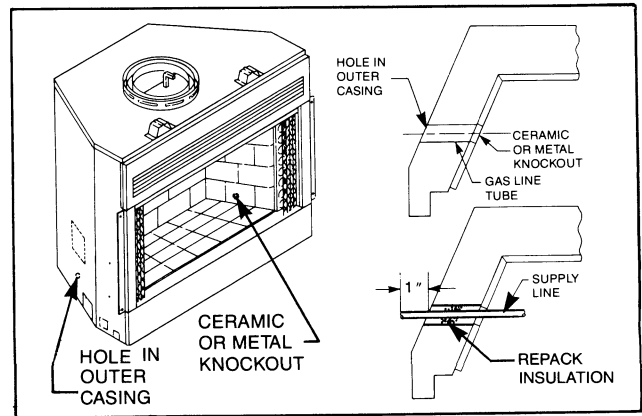

Fig. 28. Install iron pipe gas line through provided hole in either side of fireplace.

Reference Data

AIR SPACE DATA

Any MAJESTIC MBC Series fireplace can be located directly on a flat hard-surfaced combustible floor, against a combustible wall or on a wooden platform without air space from combustible construction. Some protection, however, is required for adjacent surfaces as detailed in Fig. 29.

Framing members can be placed directly against the side and back of the fireplace.

The minimum air space-to-combustibles requirements for chimney sections and dome are detailed in Fig. 29.

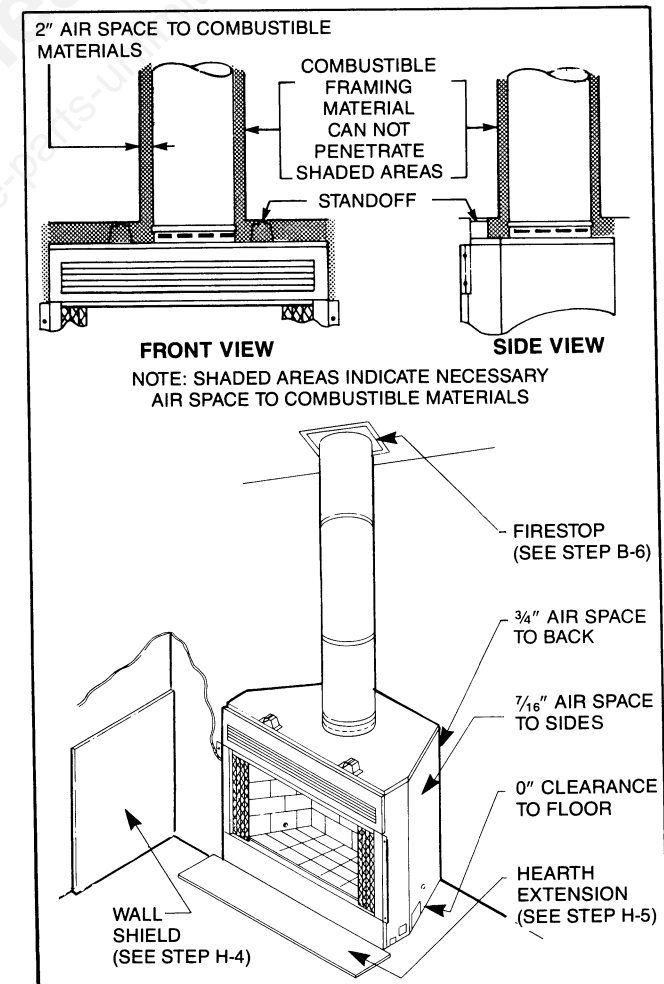

Fig. 29. Minimum air spaces to combustible materials.

FRAMING DATA

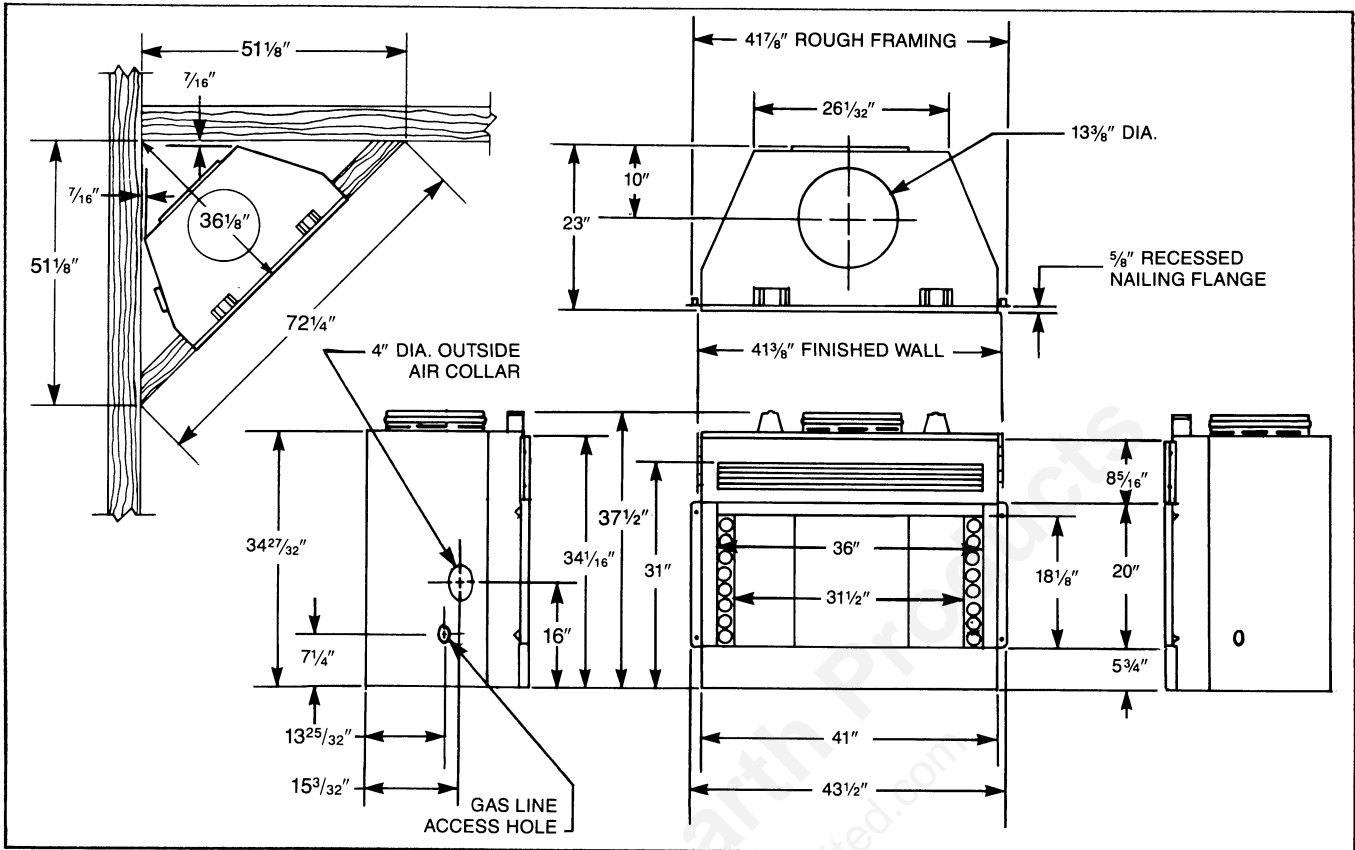

Fig. 30. Dimensions of MBC36A Series.

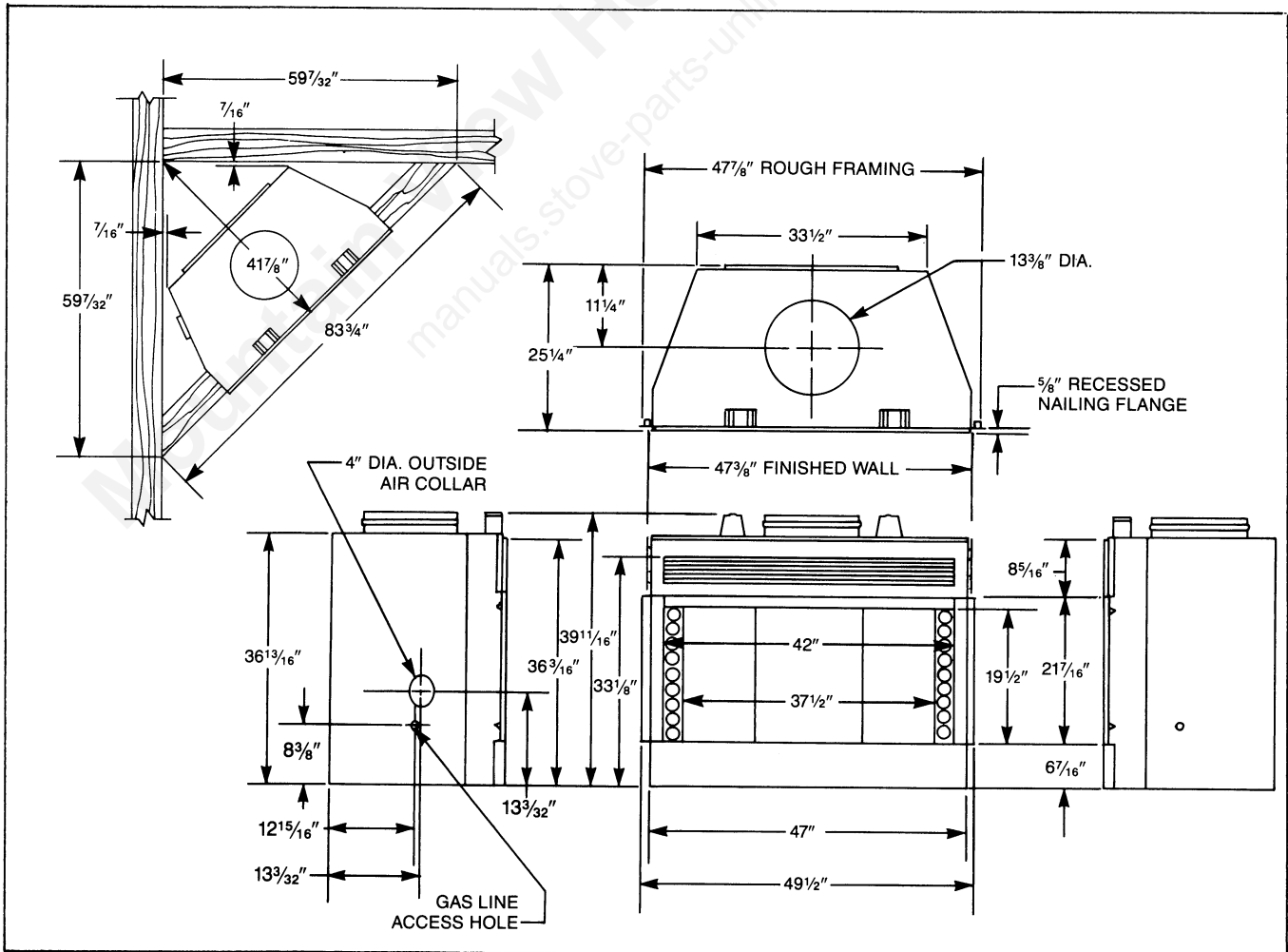

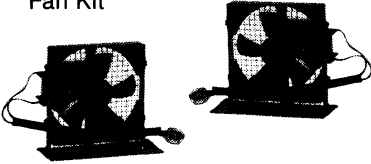
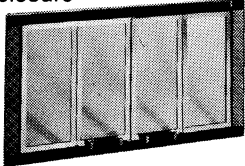
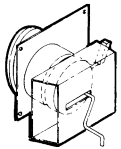



Fig. 31. Dimensions of MBC42.

Accessory Parts

The following accessory parts can be obtained from your Majestic Dealer. The fan kit, top terminations, outside air kit, glass doors, and hearth patching kits are supplied with installation instructions packaged with the unit. Should you need additional information beyond what your dealer can furnish, contact the Majestic Company, Huntington, Indiana 46750, Attention: Director of Customer Service.

CAUTION: This fireplace and chimney assembly is a highly engineered system and, as such, must be operated only with Majestic approved components that have been designed as parts of the system. If you use an unapproved component or make any modifications, you may possibly cause a fire hazard and will void the Majestic warranty. In addition, such action may void the coverage provided by the owner's home insurance.

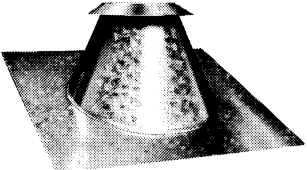

SECTION 1

Accessory	Description	Model No.
<p>Fan Kit</p> 	<p>Designed for use with the fireplace to provide forced air flow. Two each of the fans. For use with MBC Series fireplace.</p>	<p>MFK</p>
<p>Glass Enclosure Kit</p> 	<p>Designed to enclose the MBC Series fireplace opening with glass doors allowing the fire to remain visible.</p>	<p>MBD36 MBD42</p>
<p>Outside Air Kit</p> 	<p>Designed to provide outside air for fuel combustion in the firebox. This accessory must be installed before the fireplace is installed.</p>	<p>MBA-36A MBA-42A</p>
<p>Junction Box Kits</p> 	<p>Dual Wiring Kit or Single Wiring Kit for prewiring MBC36A or MBC42.</p>	<p>DWK or DWK-42 or SWK or SWK-42</p>
<p>Wall Shield</p> 	<p>Used to protect walls adjacent to the fireplace.</p>	<p>SP40</p>
<p>Hearth Extension</p> 	<p>Located on the floor in front of the fireplace opening to protect the floor from heat, hot embers, ashes, etc.</p>	<p>EH36A EH42A</p>
<p>Contemporary Flashing</p> 	<p>Required for contemporary round top termination on the roof to prevent rain entry.</p>	<p>8-6-12 (8" flue: 0 to 6/12 pitch) 8-12-12 (8" flue: 6/12 to 12/12 pitch)</p>

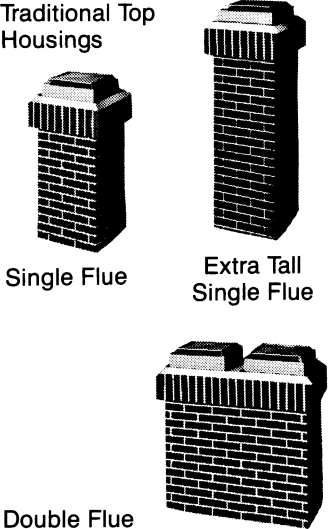
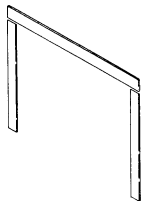
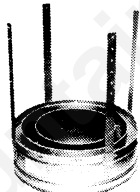
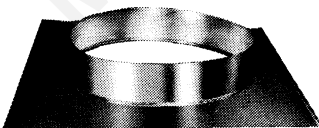
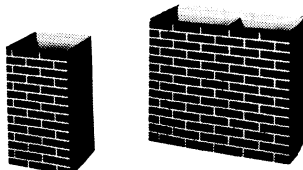

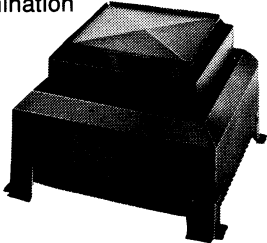
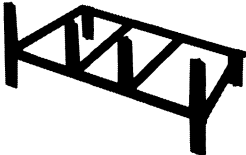

SECTION 1 (Continued)

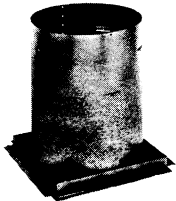
Accessory	Description	Model No.
<p>Hearth Patching Kit</p>	<p>Used to patch cracks in hearth.</p>	<p>HPC1</p>
<p>Traditional Top Housings</p>  <p>Single Flue Extra Tall Single Flue</p> <p>Double Flue</p>	<p>Gives traditional chimney top look using simulated brick in red, tan or white color. Brick pattern is embossed into galvanized steel unit. Roof flashing is included. Appropriate adapter is required. See Sections 2 and 3.</p>	<p>T20A (single flue) TL20A (extra tall single flue) T44A (double flue)</p>
<p>Trim Kits</p> 	<p>Used to trim off fireplace surround of MBC36A Series fireplace.</p>	<p>MBSTK-36 Surround Trim Kit</p>
<p>Chimney Support</p> 	<p>Used to support the chimney at each 30 feet of vertical height above the hearth and at every 6 feet of inclined chimney run. Each support adds 3 inches to chimney length.</p>	<p>TCS8 (8" flue)</p>
<p>Chase Top Flashing</p> 	<p>Used with chase terminations to prevent rain entry.</p>	<p>FL88 (8" flue)</p>
<p>Housing Extensions</p> 	<p>Required to extend Traditional Top Housings on steeply pitched roofs.</p>	<p>202036 (single flue) 204436 (double flue)</p>

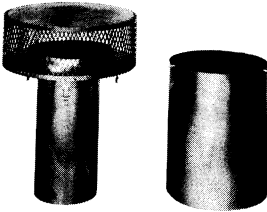
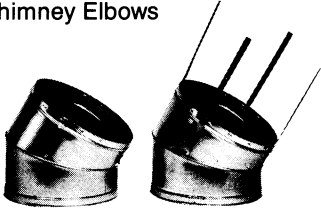

SECTION 1 (Continued)

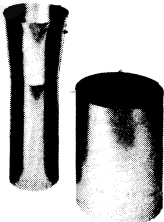
Accessory	Description	Model No.
<p>Contemporary Chase Top Termination</p> 	<p>Used to terminate chimney at the top of a chase. Flashing is not included. Appropriate adapter is required. See Sections 2 and 3.</p>	<p align="center">TT200B</p>
<p>Basket Grate</p> 	<p>Used in the firebox to hold firewood.</p>	<p align="center">Standard Equipment — Replacement RBG36 or RBG42</p>
<p>Firestop</p> 	<p>Required at each floor level and attic on multi-story installation.</p>	<p align="center">FS2A (8" straight flue) FS6A (8" 30° inclined flue) FS9A (8" 15° inclined flue)</p>
<p>Radiant Shield</p> 	<p>Used as an alternate to the FS2A firestop to reduce the clearance from the chimney to combustible framing.</p>	<p align="center">RS-8A</p>

**SECTION 2
(2 Wall Chimney Components)**

Accessory	Description	Model No.
<p>Contemporary Round Top Termination</p> 	<p>Used to terminate chimney on the roof. Flashing not included.</p>	<p>CFC8-36 CFC8-42</p>
<p>Extended Round Top Chase Termination</p> 	<p>For use with MAJESTIC type "CF" Chimney Systems. Used to terminate chimney at the top of a chase. Adapter kit included. Flashing not included.</p>	<p>CFC8L-36 CFC8L-42</p>
<p>Chimney Elbows</p> 	<p>Used to develop offset chimney systems. Both 15° and 30° elbows are available. (8 inch elbows packed 2 per carton — upper and lower elbow set)</p>	<p>CF815/2 (8" 15° flue) CF830/2 (8" 30° flue)</p>
<p>Adapter Kit</p> 	<p>Required to unite chimney with Traditional Top Housing.</p>	<p>CF8CA (8" flue)</p>
<p>Adapter Kit</p> 	<p>Required to unite chimney with Contemporary Chase Top.</p>	<p>CFTT8CB (8" flue)</p>
<p>Chimney Sections</p> 	<p>Used to build chimney systems.</p>	<p>8" flue CF81 (1' long) CF818 (1½' long) CF83 (3' long) CF84 (4' long)</p>

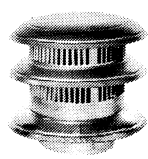
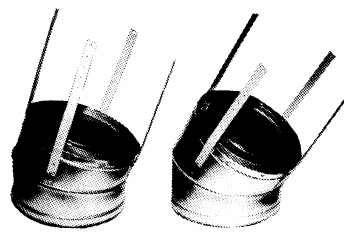
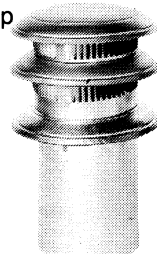
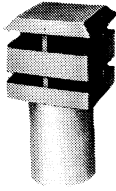
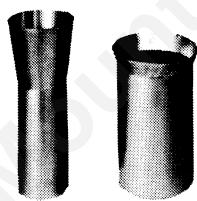
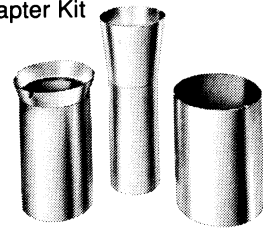
**SECTION 3
(3 Wall Chimney Components)**

Accessory	Description	Model No.
<p>Contemporary Round Top Termination</p> 	<p>Used to terminate chimney on the roof. Flashing not included.</p>	<p>RT8C (8" flue)</p>
<p>Chimney Elbows</p> 	<p>Used to develop offset chimney systems. Both 15° and 30° elbows are available. (Elbows packed 2 per carton — upper and lower elbow set)</p>	<p>815/2 (8" 15° flue) 830/2 (8" 30° flue)</p>
<p>Extended Round Top Chase Termination</p> 	<p>Used to terminate chimney at the top of a chase. Adapter kit included. Flashing not included.</p>	<p>RT8CL (8" flue)</p>
<p>Square Top Chase Termination</p> 	<p>Used to terminate chimney at the top of a chase. Adapter kit included. Flashing not included.</p>	<p>TS8 (8" flue)</p>
<p>Adapter Kit</p> 	<p>Required to unite triple-wall chimney with Traditional Top Housing.</p>	<p>8CA (8" flue)</p>
<p>Adapter Kit</p> 	<p>Required to unite triple-wall chimney with Contemporary Chase Top.</p>	<p>TT8CB (8" flue)</p>
<p>Chimney Sections</p> 	<p>Used to build chimney systems.</p>	<p>8" flue 81 (1' long) 818 (1½' long) 82 (2' long) 83 (3' long) 84 (4' long)</p>

**SECTION 3
(3 Wall Chimney Components Continued)**

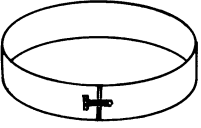
Accessory	Description	Model No.
<p>ChimneyBand</p> 	<p>Used ONLY with 3 wall chimney reduce air infiltration.</p>	<p>TWC8A</p>

Mountain View Hearth Products
manuals.stove-parts-unlimited.com



MAJESTIC Fireplaces are listed, certified, and/or accepted by leading national and local building codes and authorities including:



Underwriters' Laboratories, Inc.



Council of American Building Officials
Report No.
NER181 (MBC36 SERIES) AND
NER244 (MBC42 SERIES)