

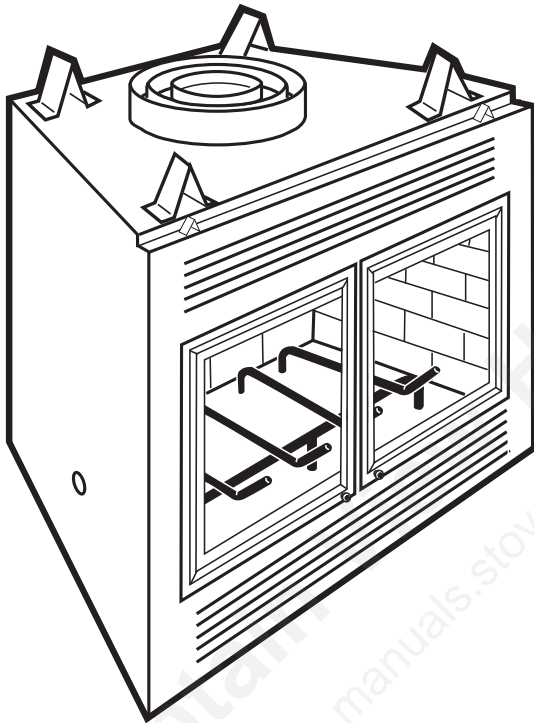

BFC

Balanced Flue (Closed Combustion) Heat-Circulating Fireplace



Model:
BFC36

Homeowner's Installation and
Operating Manual



For use in the U.S. / Canada
Underwriter's Laboratories
Report No. MH7603

NATIONAL FIREPLACE INSTITUTE

CERTIFIED
www.nficertified.org

We recommend that our woodburning hearth products be installed and serviced by professionals who are certified in the U.S. by the National Fireplace Institute® (NFI) as NFI Woodburning Specialists or who are certified in Canada by Wood Energy Technical Training (WETT).

 **Wood Energy Technical Training**
www.wettinc.ca

DO NOT DISCARD THIS MANUAL: Retain for future use.

7412647 2/10 Rev. 18

Table of Contents

Safety Information.....	3
Specifications and Framing	4
Parts Identification	6
Chimney Requirements	7
Planning Information	8
Installation	9
Replacement Parts	19
Accessories	21
Warranty.....	23

**BFC36
Listed**

**UL127 / ULC-S610
Standard for Factory Built Fireplaces**

Safety Information

Please Read This Manual Before Installing and Using Fireplace

IMPORTANT: Read all instructions and warnings carefully before starting installation. Failure to follow these instructions may result in a possible fire hazard and will void the warranty.

Description

The BFC36 fireplace is a solid fuel, woodburning fireplace. The BFC36 is a balanced flue (closed combustion) heat-circulating fireplace which receives outside combustion air through the chimney system. This unique system results in much higher efficiency since valuable room air is not used for combustion.

The BFC36 is a decorative fireplace which provides efficient supplemental heat compared to other wood burning fireplaces. It should not be used as a primary source of heat.

CAUTION: Overloading the firebox with wood may result in overfiring and damage to refractory components, the grate and doors.

Precautions

MHSC fireplaces and component parts have been thoroughly tested and will operate safely when installed in accordance with instructions provided in this manual. Carefully read and understand all instructions **before** beginning installation.

If you notice any damage to fireplace or component parts, immediately report damage to your MHSC dealer.

Only use MHSC components or the warranty will be voided and a fire hazard may be created.

MHSC warranty will be voided by and MHSC disclaims any responsibility for the following actions:

- **Installation by any other than a qualified installer, preferably NFI or WETT (Canada) certified.**
- **Installation of any damaged fireplace or chimney component;**
- **Modification of fireplace, chimney assembly or any component parts thereof;** (except for chase flashings as detailed in MHSC Chimney Top installation instructions).
- **Installation other than as instructed by MHSC;** or
- **Installation and/or use of any component part not manufactured or approved by MHSC in combination or assembly with a MHSC fireplace system, notwithstanding any independent testing laboratory or other third party approval of such component parts or accessory.**

Any such action may possibly cause a fire hazard.

7412647

Consult local building codes to ensure that you are in compliance **before** installing the fireplace.

This fireplace and chimney system must be vented to the out-of-doors.

Do not obstruct or modify air inlets/outlets in any manner.

Do not install combustible materials on any of the black fireplace surround.

Burn only solid wood fuel or gas logs.

The BFC36 is intended for operation only with the doors closed.

Do not install a solid fuel burning insert or other products not specified for use with this fireplace.

Proposition 65 Warning: Fuels used in gas, wood-burning or oil fired appliances, and the products of combustion of such fuels, contain chemicals known to the State of California to cause cancer, birth defects and other reproductive harm.

California Health & Safety Code Sec. 25249.6

WARNING: Check with your electronics manufacturer before installing a television or other electronic device above this fireplace.

drants (ie. frequently opened doors and central heating air inlets/outlets) that hamper the normal flow of air into the fire.

installed before framing the fireplace. The gas line must be installed by a certified gas line installer.

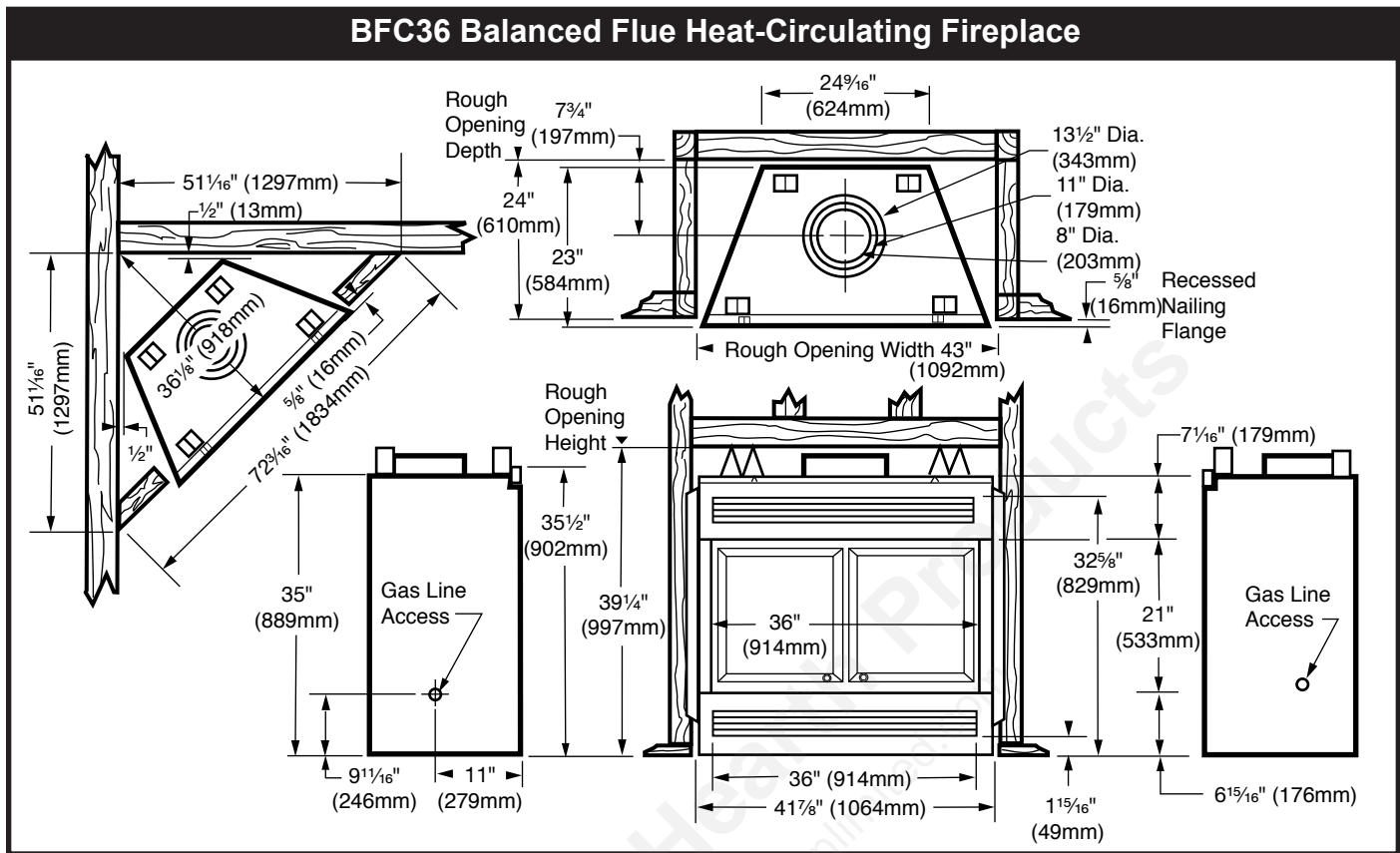

Fig. 1 BFC36 specifications and framing.

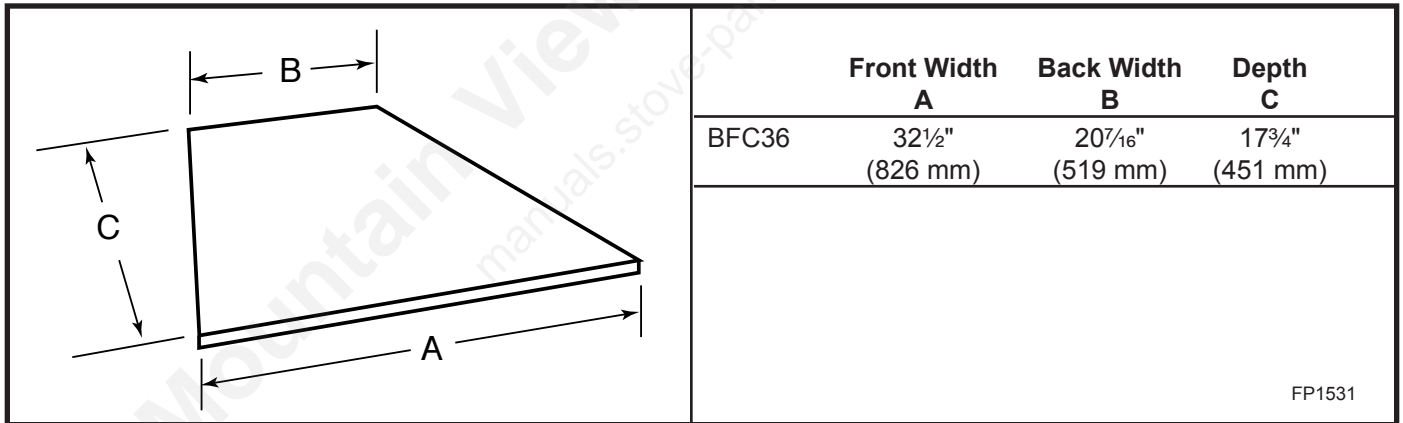
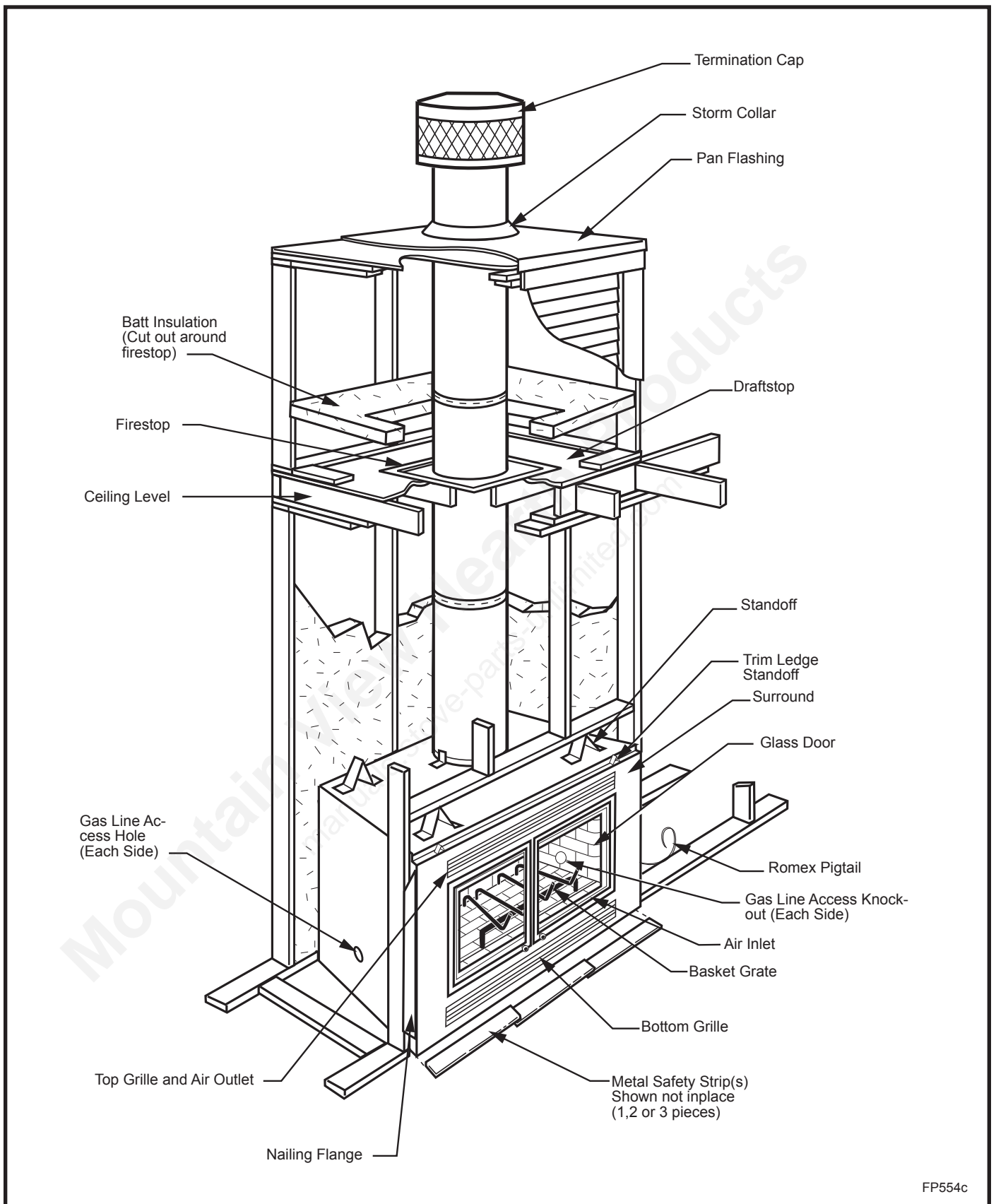

Fig. 1a Hearth dimensions.



FP554c

Fig. 2 Fireplace and chase parts identification.

Chimney Requirements - Offset Installations

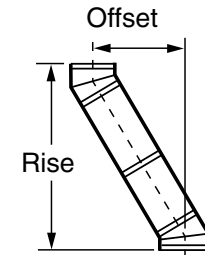
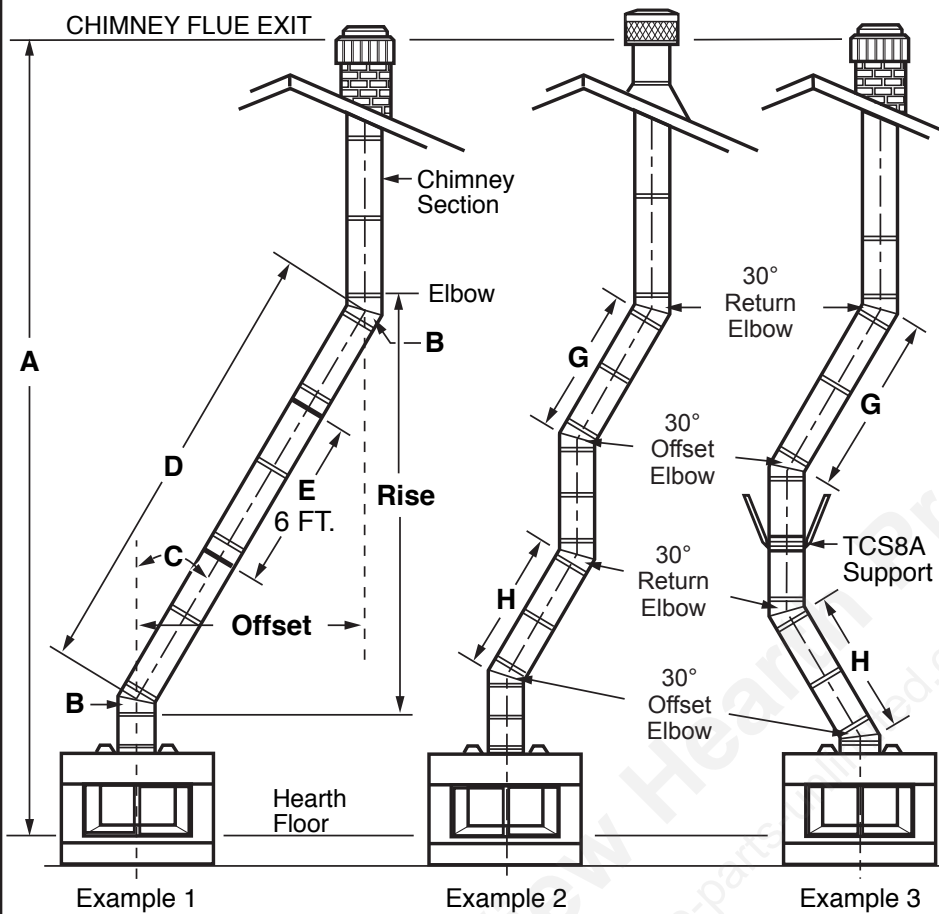

IWF282

30° Elbow Offsets

1'	1½'	3'	4'	Chimney Support	Offset	Rise
0	0	0	0	0	3"	11"
1	0	0	0	0	8¼"	20"
0	1	0	0	0	11¼"	25¼"
2	0	0	0	0	13½"	29¼"
1	1	0	0	0	16½"	34¼"
0	0	1	0	0	20¼"	40¾"
2	1	0	0	0	21¾"	43½"
0	0	0	1	0	26¼"	51¼"
0	1	1	0	0	28½"	55¼"
1	0	0	1	0	31½"	60¼"
0	1	0	1	0	34½"	65½"
0	0	2	0	0	37½"	70¾"
1	1	0	1	1	41½"	77¾"
0	0	1	1	1	45"	83¾"
0	1	2	0	1	47¼"	87½"
0	0	0	2	1	51"	94"
0	1	1	1	1	53¼"	98"
0	0	3	0	1	56¼"	103¼"
0	1	0	2	1	59¼"	108½"
0	0	2	1	1	62¼"	113½"
0	1	3	0	1	64½"	117½"
0	0	1	2	1	68¼"	124"
0	1	2	1	1	70½"	128"
0	0	0	3	1	74¼"	134½"
0	1	1	2	2	78"	140¾"
0	0	3	1	2	81"	146"
0	1	0	3	2	84"	151¼"
0	0	2	2	2	87"	156½"
0	1	3	1	2	89¼"	160¼"
0	0	1	3	2	93"	166¾"
0	1	2	2	2	95¼"	170¾"
0	0	0	4	2	99¼"	177¾"
0	1	1	3	2	101¼"	181¾"
0	0	3	2	2	104¼"	186¼"
0	1	0	4	2	107¼"	191½"
0	0	2	3	2	110¼"	196¾"
0	1	3	2	3	114"	203¼"
0	0	1	4	3	117¾"	209¾"
0	1	2	3	3	120"	213½"
0	0	0	5	3	123¾"	220"

Notes: G + H cannot exceed 20 feet.
Air Space Clearances: = 2" Min. to Combustibles

Illustration Key

The following safety rules apply to offset installations (letters correspond with illustration above):

A. Height of the chimney is measured from the hearth to the chimney exit.

Maximum:	BFC36
	50'0"
Minimum:	
Without Elbows	14'6"
With 2 Elbows*	14'6"
With 4 Elbows*	21'0"

B. Do not use more than 4 elbows per chimney.

Attach the straps of the return (top) elbow to a structural framing member.

The offset (first) elbow of any pair does not have straps.

C. The chimney cannot be more than 30" (45" in Canada) from the vertical plane in any installation*.

D. The maximum length of the angled run of the **total** chimney system is 20 feet. (G plus H cannot exceed 20 feet.)

E. A chimney support (Model TCS8A) is required every 6 feet of angled run of chimney. Chimney supports are required for every 30 feet and 60 feet of vertical chimney height above the hearth.

Determine the offset distance of your chimney arrangement from the centerline of the fireplace to the centerline of the chimney where it is to pass through the first ceiling.

NOTE: This offset distance may not be your full offset distance. See Examples 2 and 3.

FP269

Fig. 3 Chimney system requirements.

Planning Information

Preplanning an installation is very important to ensure safety and to save time and money. An installer must predetermine where a fireplace will be set and how the chimney system will be run.

Mounting the Fireplace

A fireplace may only be mounted on the following surfaces:

1. A flat combustible surface.
2. A raised wooden platform.
3. A concrete block or other solid object placed beneath each of the four (4) corners of the fireplace.

The fireplace **must** be spaced 1" (25mm) from a combustible back wall and 1/2" (13mm) from a combustible side wall or support. (Page 13, Fig. 17)

Planning the Chimney Run

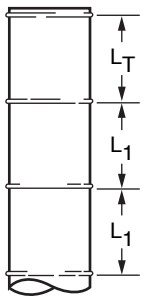

TRIPLE WALL	TOTAL LENGTH (L _T)	INSTALLED LENGTH (L ₁)
81	11½"	10½"
818	17½"	16½"
83	35½"	34½"
84	47½"	46½"

FP288a

Fig. 4 Installed lengths of chimney sections.

Determine how the chimney will be run, length of run and chimney components required to complete the job. (Fig. 4) **Never** install a chimney below minimum heights.

In planning a chimney system, it is important to know:

1. The height of a chimney is measured from the hearth to the exit point on the termination.
2. A chimney cannot be offset more than 30° from a vertical plane.
3. A chimney may run straight up or it may be necessary to offset it to avoid obstructions.
4. The maximum length of an angled run (total chimney system) is 20' (6m).
5. No more than 2 offsets (4 total 30° elbows in U.S./or 2 total 45° elbows in Canada) per fireplace may be used.
6. A guy wire stabilizer is required for chimneys extending more than 6' (1.8m) above a roof line.

The Ten Foot Rule

Major U.S. building codes specify a minimum chimney height above the roof top. The "Ten Foot Rule" is a fire safety rule and not a draft rule. To ensure proper draft, it is recommended that you always meet or exceed the "Ten Foot Rule," especially when installing a termination on a high pitch roof. (Fig. 5)

The key points of the "Ten Foot Rule" are:

1. If the horizontal distance from the chimney to the peak of the roof is 10' (3m) or less, the top of the chimney must be at least 2' (610mm) above the peak of the roof, but never less than 3' (914mm) in height above the highest point where it passes through the roof.
2. If a horizontal distance from the chimney to the peak of the roof is more than 10' (3m), a chimney height reference point is established on the surface of the roof a distance of 10' (3m) from the chimney in a horizontal plane. The top of the chimney must be at least 2' (610mm) above the reference point, but never less than 3' (914mm) in height above the highest point where it passes through the roof.

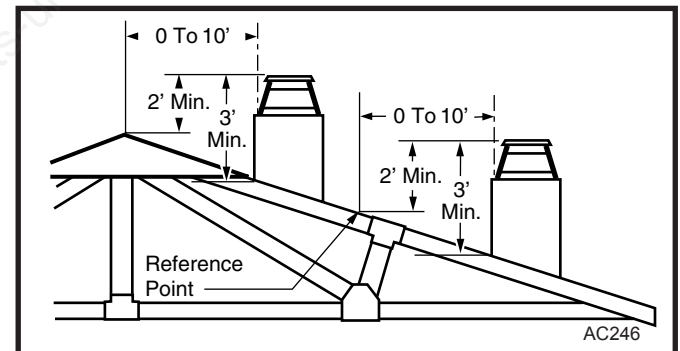

Fig. 5 Ten Foot Rule illustration.

Chimney Supports

The chimney system is supported by the fireplace for vertical chimney heights less than 30' (9m) above the hearth. Chimney supports are required if the vertical height exceeds 30' (9m). Locate chimney supports at ceiling holes or other structural framing at 30' (9m) heights. Spacing between chimney supports **must not** exceed 30' (9m). Use Chimney Support Model TCS8A. **(NOTE: The TCS8A cannot be mounted directly to the fireplace.)** Support provided by elbow straps fulfills the support requirement only if they are spaced as previously described. (A chimney support is 2½" (64mm) long when installed.)

Angled chimney runs require a support every 6' 1.8m) in addition to the elbow straps. Chimney supports are used for this function. (Fig. 6)

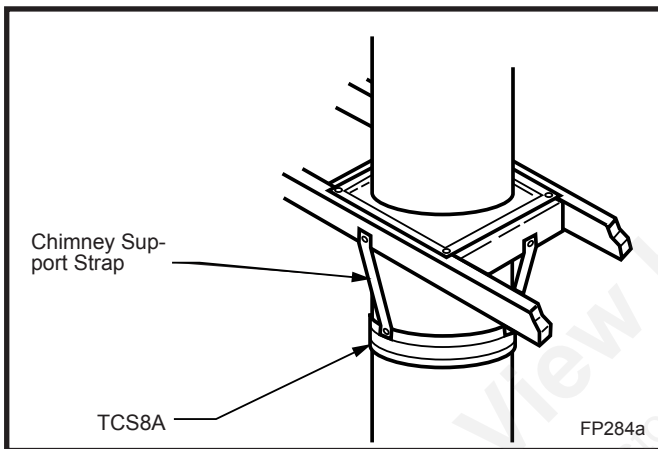

Fig. 6 Chimney support installation.

Chase Installation

A chase is a vertical box-like structure which encloses the fireplace and/or chimney. Chases are typically built on the outside of the house with fireplace opening cut into the outer wall of a room. (Page 4, Fig. 2)

If you need help in determining fireplace location or how the chimney system should be run, contact your MHSC dealer for assistance.

Installation

Insulating Fireplace Enclosure for Cold Climates

If you live in a cold climate, it is not required but **highly recommended** that you insulate fireplace enclosure to eliminate cold air penetration as much as possible.

Insulate base of fireplace with a noncombustible insulation rated for a minimum of 300°F. Insulating is **very important** for outside wall installations over a concrete slab. If fireplace is installed on a platform, insulation should be placed on top of the platform **before** fireplace is set. (Fig. 7)

When a fireplace is installed in a chase or on a outside wall, enclosure should be treated like any outside wall in a home. Insulation should be installed on the inside wall as well as the outside wall(s). In a chase, it is also a good idea to install a firestop at the first ceiling level above the fireplace and enclose the chase with sheeting material. Insulation may then be installed above sheeting material to assure the space around the fireplace is totally protected. (Fig. 2)

When installing the chimney, **DO NOT** caulk between outer pipe and firestop. It is vital that some air be allowed to flow through this very thin gap.

CAUTION: When installing a fireplace in an insulated enclosure, be sure all required air spaces are maintained. (Page 13, Fig. 17)

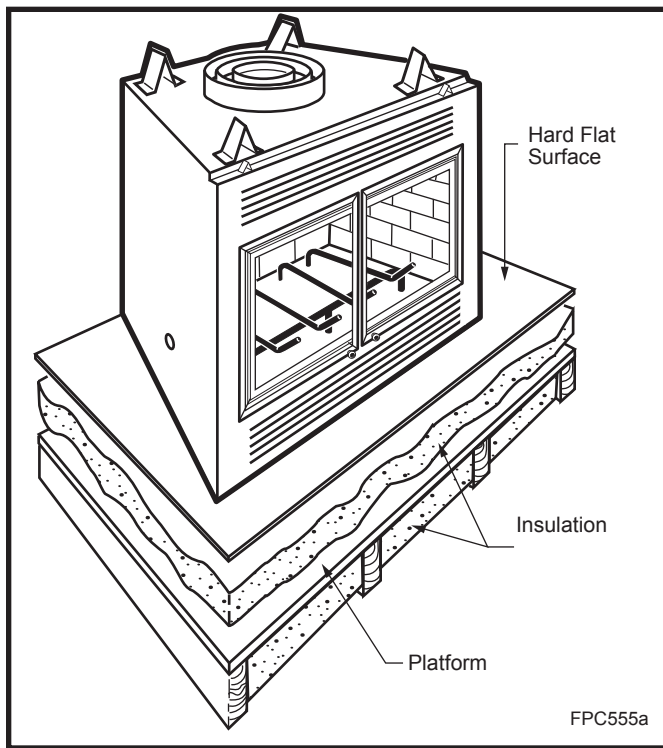

Fig. 7 Insulating between platform and fireplace.

Framing

Framing can be constructed before or after the fireplace is set in place, however, most installers build the frame before setting the fireplace.

Frame fireplace with 2 x 4 lumber or heavier materials. Refer to framing dimensions in Figure 1 for basic fireplace specifications.

NOTE: Framing should be positioned to accommodate wall covering and fireplace facing material.

Installing Electrical Wire

The fan requires 120VAC, 60 Hz power which may be connected to the right side of the fireplace using the romex pigtail provided with the unit. This power must be completed **before** the fireplace is secured and finish material applied.

1. Attach the white wire from house power to the white wire of the romex pigtail and secure with a wire nut.
2. Attach the black wire from the house power to the black wire of the romex pigtail and secure with a wire nut.
3. Attach the ground wire from house power to the ground wire of the romex pigtail and secure with a wire nut. (Fig. 8)

IMPORTANT: The wire nuts must be tight.

NOTE: Check local building codes to determine if junction box is required at the romex pigtail/house wire connection. Also check junction box and speed control (SCVS) installation instructions.

The Model FKSX-A blower assembly is preinstalled in the BFC36.

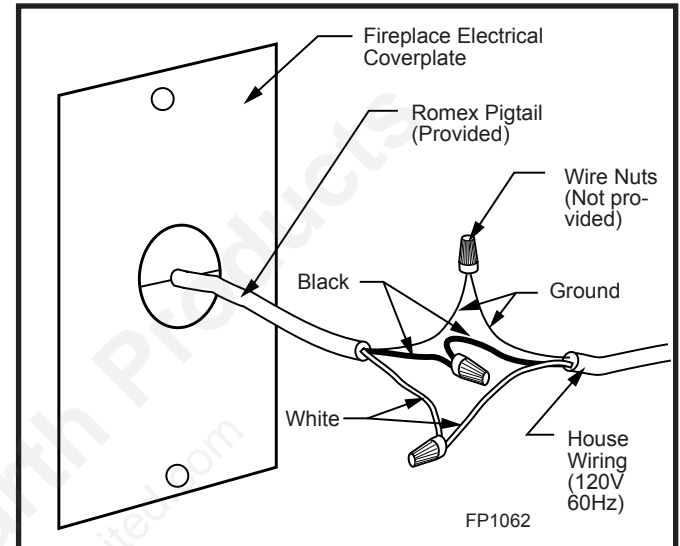

Fig. 8 Wiring diagram.

Chimney Set-up

Since you have already preplanned the chimney run, you should know exactly how the installation is to be accomplished — how much pipe is required, the number of elbows, if any, and type of termination to be used.

CAUTION: REPORT TO YOUR DEALERS ANY PARTS DAMAGED IN SHIPMENT, SPECIFICALLY CHECK THE END CONNECTION OF CHIMNEY SECTIONS AND ELBOWS.

NOTE: The BFC36 fireplace **must** use MHSC Model triple wall 8" chimney components only. The installation procedure described in this manual applies only to this system.

Straight-Up Chimney Installation

To mark the centerline of the flue, put the fireplace in final position and measure out from the wall: 8 $\frac{3}{4}$ " (222 mm). Mark a spot on the ceiling directly above the fireplace. Draw a line parallel to the back wall through this mark. (Fig. 9)

Using a plumb bob positioned directly over center point of fireplace flue collar, mark the ceiling to establish the chimney center point. (Fig. 9)

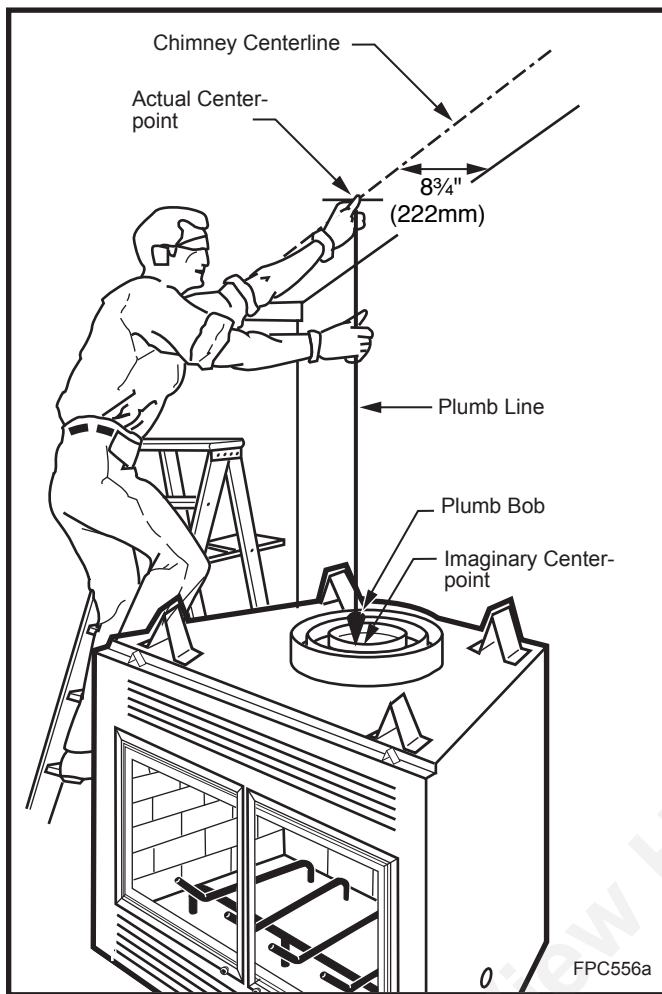

Fig. 9 Locate centerline of chimney with plumb line.

Offset Installation

In order to clear an obstruction, it may be necessary to offset chimney from vertical. This is accomplished by using elbows. Use the *30° Offset Elbow* table on Page 5 to determine proper offset and parts required.

Each offset requires two (2) elbows. The second elbow is equipped with support straps. It is very important to install the second elbow in each offset as close to the ceiling or support as possible so that the elbow straps can be secured to framing members to help support the weight of the chimney.

Determine offset distance of your chimney arrangement from centerline of fireplace to centerline of chimney where it is to pass through ceiling.

Locate center point of the chimney on ceiling as though a straight up chimney arrangement is to be used. Measure your offset dimension from straight up chimney center point on ceiling.

Ceiling Chimney Hole/ Possible Obstructions

The size of the hole in ceiling will vary with the angle at which the chimney passes through ceiling.

Drive a nail up through ceiling at marked chimney center point. Go to floor above and see where hole will be cut. Check to see where existing ceiling joists and other possible obstructions are located...i.e. wiring, plumbing etc... If necessary, re-position chimney and/or fireplace to avoid obstructions.

Cutting the Hole

Cover fireplace collar opening and cut proper sized chimney hole in chimney.

Framing the Ceiling Hole

Frame the ceiling chimney hole as shown in Figure 10. It is good practice to use framing lumber that is the same size as the ceiling joists; this is a requirement at attic level.

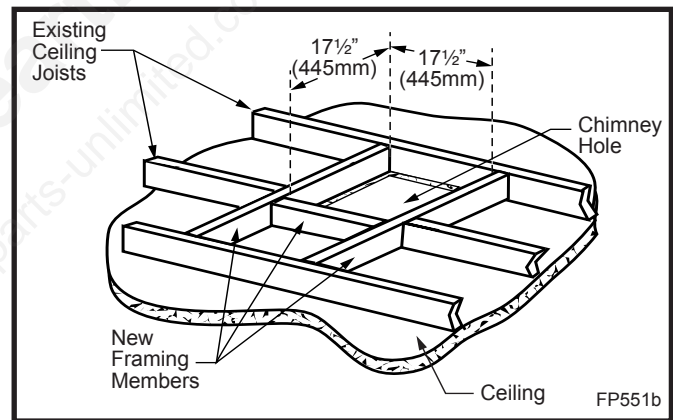

Fig. 10 Typical frame for ceiling chimney hole.

The following table gives firestop spacer model numbers:

Chimney Hole Size

Size of Chimney	Angle of Chimney at Ceiling	
	Vertical	30°
8" Flue	FS2A 17 1/2" x 17 1/2" (445 x 445mm)	FS6A 17 7/8" x 29 5/8" (454 x 753mm)

Fig. 11 Ceiling chimney hole sizes necessary for installing firestop spacer.

The **inside dimension** of the frame **must be** the same as the hole size selected from Figure 11 in order to provide required the 2" (51mm) air space between the outside diameter of the chimney and the edges of the framed ceiling hole.

Positioning, Safety Strips, Securing the Fireplace

Slide fireplace into position.

Lift the fireplace front slightly and slide the metal safety strips under front bottom edge about 1½" (38mm), allowing the remainder to extend in front of firebox. Overlap strips at least ½" (13mm) to provide a positive joint. (Flat safety strips are packed with fireplace.) (Fig. 12)

Safety strips are used to ensure that any combustible materials in front of the fireplace are protected even though a non-combustible hearth extension is required.

If fireplace is to be elevated above the floor, a "Z" shaped metal safety strip must be fabricated and used to protect combustible surfaces in front of the fireplace. This "Z" shaped safety strip is not provided but must be fabricated of metal with each horizontal leg at least 1½" (38mm) wide and equal in length to the metals strips provided with the fireplace.

NOTE: Safety strips are not required over non-combustible floors where all supports at the base of the fireplace are noncombustible.

Four (4) nailing flanges are supplied with the fireplace (found on the fireplace hearth). To level the box and secure it firmly in place, remove the nailing flanges from the hearth and install at the sides of the fireplace as shown in Figure 13.

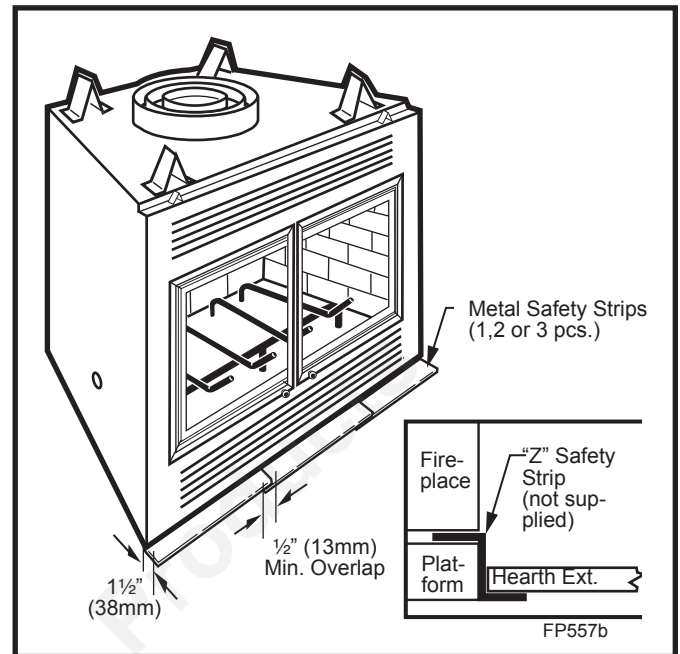

Fig. 12 Safety strip installation.

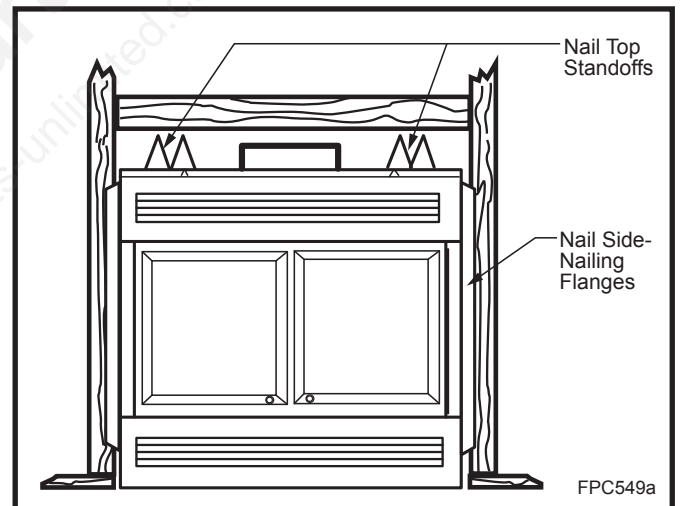

Fig. 13 Fasten fireplace in position.

Installing the Chimney System

Start by attaching the first chimney section to the collar on top of the fireplace.

Install the pipe as pictured in Figure 14. When you get a good lock, you will hear the pipe clearly snap together. Once sections are snap-locked in place, it is extremely difficult to get them apart. **Make sure the pipe is firmly snapped and locked together as each pipe section is mounted.**

When installing elbows, only outer pipe will snap-lock. Middle pipes simply slide into position. Be sure to always attach straps on upper elbow to a structural framing member. (Fig. 15)

Continue installing the pipe as required until pipe is installed up through the ceiling. At this point, you must install a firestop spacer.

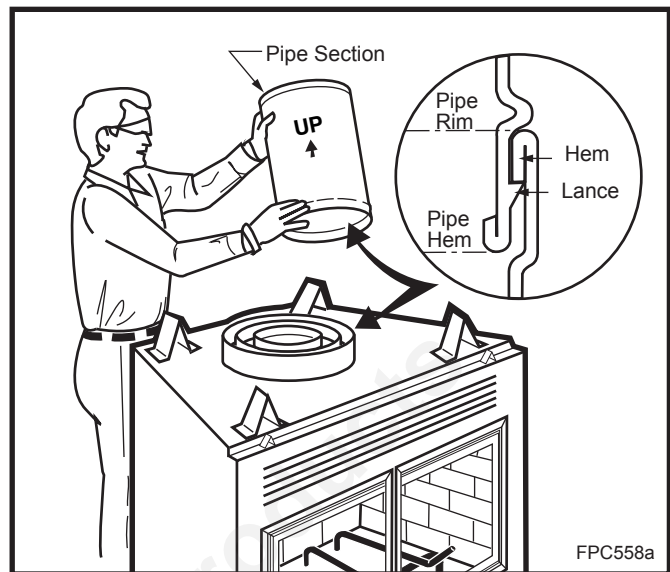

Fig. 14 Install pipe, listening for the snap-lock to fasten.

Installing the Firestop Spacer in the Ceiling Hole

A firestop spacer is used to keep pipe spaced properly and required for safety.

Nail the firestop spacer (at each corner) to the framing members of the ceiling hole. **NOTE:** A firestop spacer is not required at the roof.

Hole sizes listed in Figure 11 for angled firestop spacers provide minimum required air space to chimney pipe for ceiling thickness up to 8" (203mm). When combined thickness of ceiling material, ceiling joists and flooring material exceeds 8" (203mm), adjustments must be made in framing to assure that minimum air spaces to chimney are maintained.

Proper Firestop Spacer Installation

Figure 16 shows different installation procedures for both an area that *is* an attic and an area that *is not* an attic.

If the area above the ceiling **is not** an attic, position the firestop spacer with the flange on the ceiling side and the angled portion extending up into the hole.

If the area above the ceiling **is** an attic, position the firestop spacer with the flange on the top of the framed hole and the angled portion extending down into the hole.

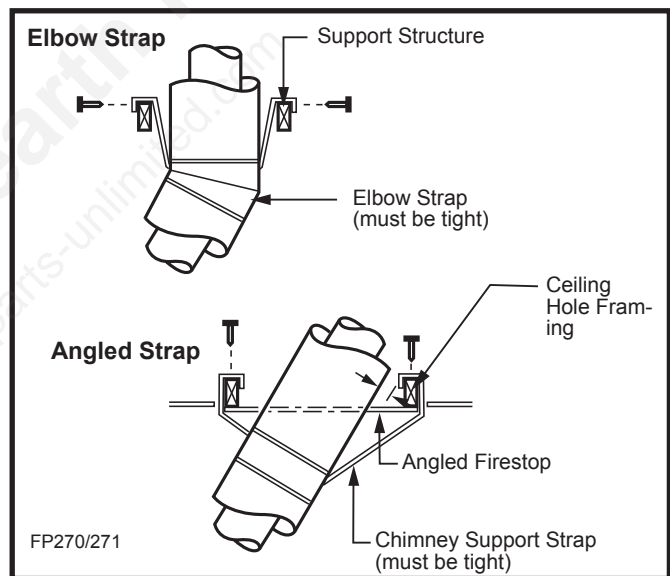

Fig. 15 Attach straps to a structural framing member.

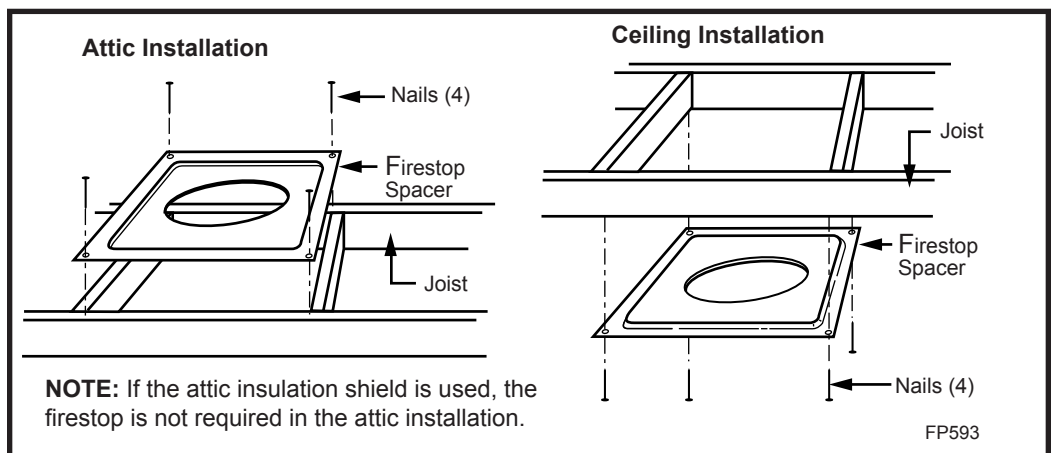

Fig. 16 Installing firestop spacer.

Firestop spacers are not available for, nor are they required on vertical walls.

DO NOT put any sealant around the area where the outer pipe slides through the firestop spacer. If you seal this area, **it may cause a fire hazard.**

Canadian Requirements for Insulation Shield

In Canada, an attic insulation shield is required to prevent attic insulation from contacting the chimney section. **NOTE:** If the attic insulation shield is used, the firestop is not required in the attic installation. Framing dimensions for the chimney hole should measure 17½" x 17½" (445 x 445mm). An attic shield **MUST** be installed on top of attic joists (above the floor level). (Fig. 17)

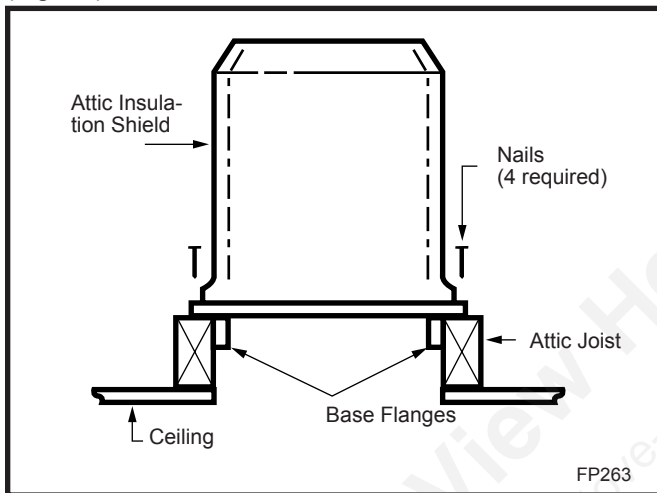

Fig. 17 Attic shield installation (Canadian requirement).

NOTE: In the U.S., it is a good idea, although not always required, to install an attic insulation shield where blown-in insulation is planned to be used in the attic.

Install the attic insulation shield with the flanges on its base extending down into the framing hole. Nail each corner of attic insulation shield to the framing members of the ceiling hole using 8d nails. Attic shields are not required at the roof.

Continue Installing Pipe to Complete Run

Continue attaching pipe sections to complete system to next level always being careful that the pipe is firmly snap-locked in place before proceeding to next pipe section.

Chimney Supports

If chimney supports are required, they are installed the same as elbows. Nail chimney support straps to adjacent structural framing, as shown on Page 8, Figure 9. Bend straps as necessary and make sure they are secure so they will support the weight of the chimney.

A chimney support is 2½" (64mm) long when installed. Consider this dimension when determining how many straight chimney sections are needed.

NOTE: Chimney supports are generally used in long runs in a chase installation.

Additional Ceilings

If you encounter additional ceilings, repeat same steps required for first ceiling installation. See firestop illustration in Page 11, Figure 16.

Penetrating the Roof

Run pipe to roofline. Since chimney system must be vented to the out-of-doors, you **must** use an approved MHSC termination.

If a chase is used, refer to the installation manual provided with the termination cap.

Locate Chimney Centerpoint On Roof

Use same procedure detailed in locating center point of the flue system.

Drive a nail up through roof at the center point. This will determine center point on outside of the roof.

Cut and Frame Roof Hole

Size of roof hole varies with the type of chimney termination installed. Refer to installation instructions provided with MHSC chimney termination to find correct size of roof hole.

There must be a 1½" (38mm) air space between outermost portion of chimney sections and any adjacent combustible surfaces. (Combustible surfaces include burnable materials such as: ceiling members, joists, flooring, combustible insulation and roof structures.)

WARNING: Do not pack required air spaces with insulation or other materials.

Mark an outline of the roof hole around the center of the point nail. **NOTE:** Hole dimensions given in the chimney top installation instructions are **horizontal** dimensions; therefore, the hole size must be marked on the roof accordingly.

Cover the opening of the installed chimney so debris cannot get into the system.

Cut and frame the hole. It is good practice to use framing lumber that is the same size as the rafters. Install the frame securely because the chimney top and flashing anchored to the frame must be able to withstand heavy winds.

Install Remainder of Chimney Sections

Since you have already preplanned the height of your termination according to the *Ten Foot Rule*, continue to install pipe to the predetermined height.

Check the chimney top installation instructions for details on how high above the roof top the chimney sections (all pipes) should extend.

Installing Top Housing or Termination

Follow the installation instructions provided with the MHSC chimney termination you have selected.

Installing Chimney in a Chase

Refer to Page 4, Figure 2 for an illustration of a typical chase installation.

CAUTION: Treatment of firestop spacers and construction of chase may vary with type of building. These instructions are not a substitute for local building codes. You **must** check your local building codes to determine specific requirements for your city or state. **NOTE:** Other building materials may be required in addition to firestop spacers.

Finishing

CAUTION: All joints between the finished wall and the fireplace surround (top/sides) must be sealed with non-combustible material to prevent cold air leakage into the room. Only noncombustible material may be applied to the facing of the fireplace surround. (Black painted area) (Fig. 18)

Finish Wall

Finish the wall with material of your choice. **Do not install a combustible mantel shelf less than 12" (305mm) above the grille opening. Do not install a mantel face plate less than 6" (159mm) from top of grille opening.** (Fig. 20) If a combustible material is used below a flat mantel shelf, consult your local building codes for minimum clearance from top of fireplace opening to bottom of mantel shelf.

All joints (top, bottom and sides) where wall or decorative facing material meets fireplace surround must be completely sealed with a noncombustible material. (Figures 19 and 20)

NOTE: No side wall protection is required for fireplaces installed at 45° to two (2) side walls (corner installation).

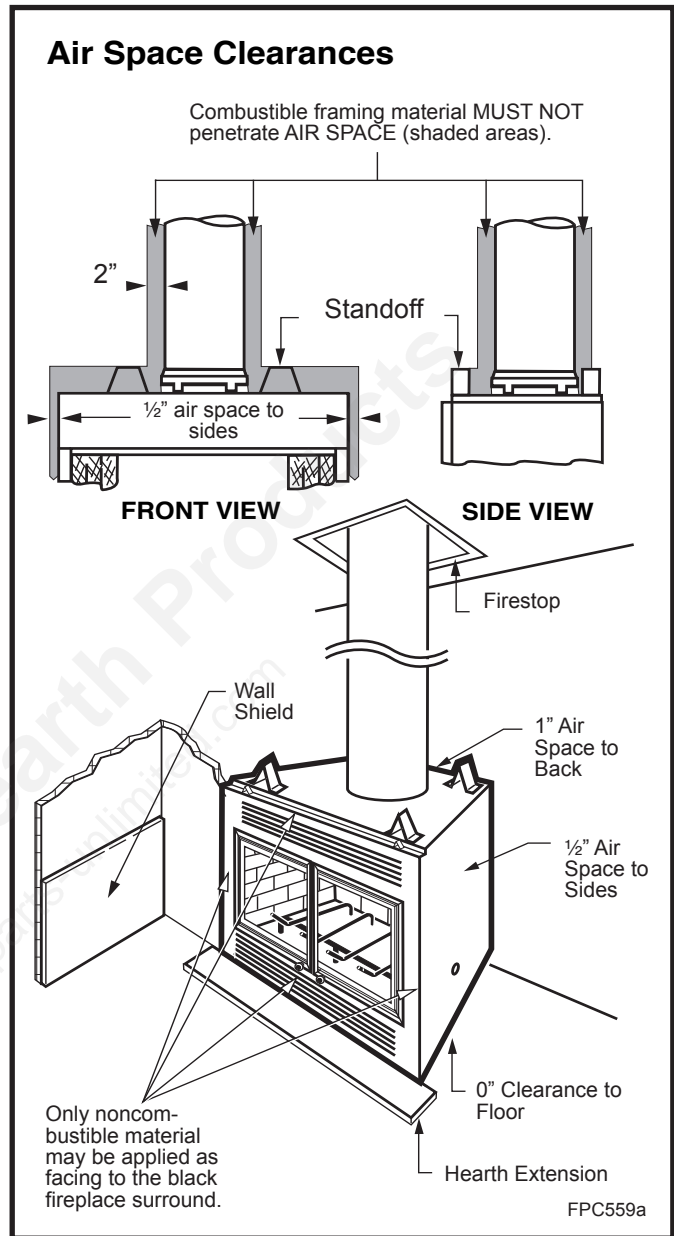

Fig. 18 Minimum clearances to combustibles.

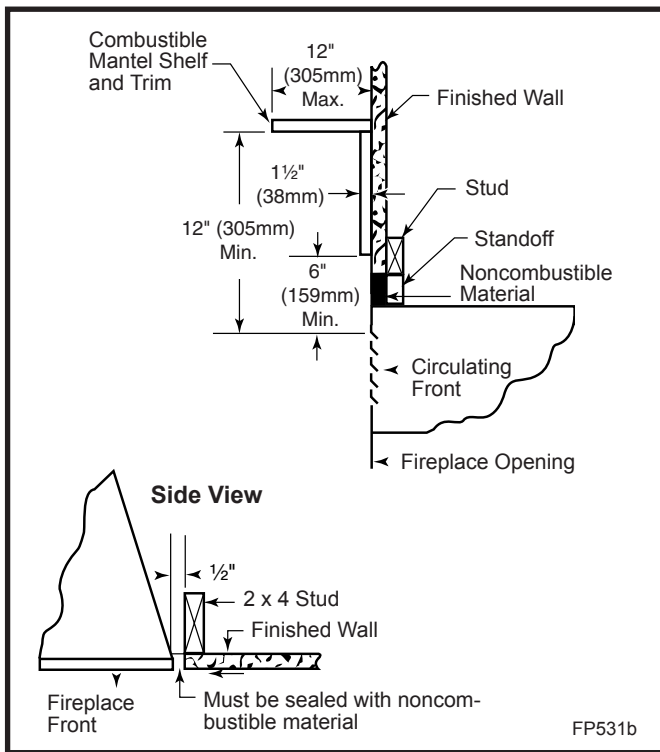
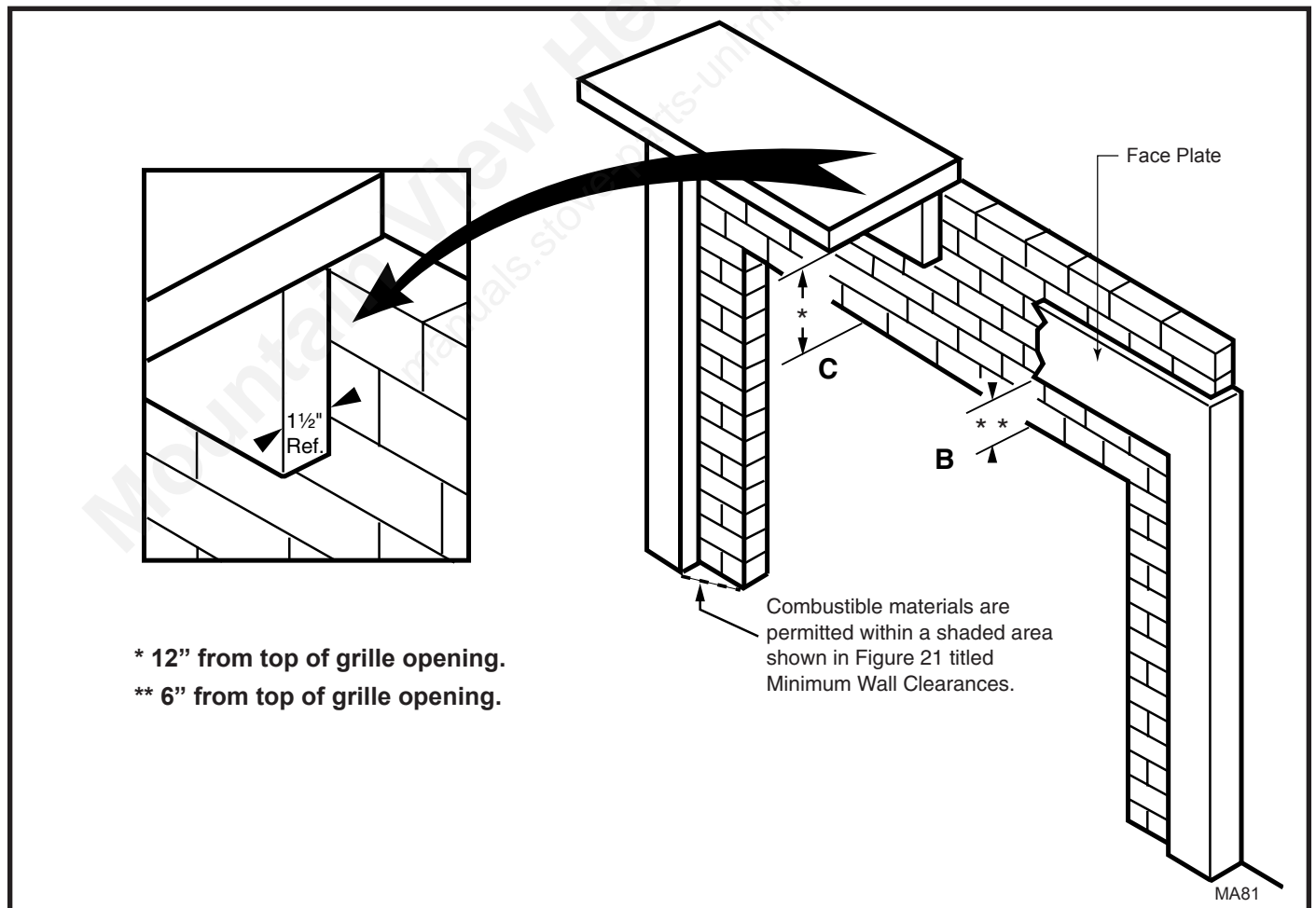

Fig. 19 Mantel clearance.



- * 12" from top of grille opening.
- ** 6" from top of grille opening.

Fig. 20 Combustible mantel clearances.

Side Wall Protection

Adjacent combustible side walls that are within minimum dimensions shown in Figure 24 of the fireplace opening must be protected with MHSC Wall Shield Model SP40 or a specifically built wall shield described in Figure 18.

The special wall shield design described in Figure 18 is an alternate method of adding protection to side walls and can be used in place of the SP40 with the same wall clearances specified for the SP40. Rt must = 1.85 minimum.

Examples of wall shield insulation:

1. Manville - CERAFORM 126, K=.27, 1/2 inches thick
2. EH2416, K = .458, 1 inch thick required.

Hearth Installation

A hearth extension is required to protect a combustible floor in front of the fireplace. Refer to Figure 21 for minimum dimensions and mounting detail.

Note: Hearth Extension must not cover the air inlet opening of a fireplace.

The hearth extension described in Figure 21 must be a durable non-combustible material with a minimum (total) Rt value of 1.09; refer to Figure 22 for examples. The overall height (above a combustible floor), depth and width must be as indicated, with the extension centered to the fireplace opening.

The top of insulation must be covered with a non-combustible decorative covering or a piece of .018" minimum sheet metal, to protect hearth extension material. (Fig. 21)

Secure the hearth extension to the floor to prevent shifting, using trim molding or other similar means at three (3) outer edges. Seal crack between the fireplace hearth and hearth extension with a non-combustible material. (Figs. 21 and 23)

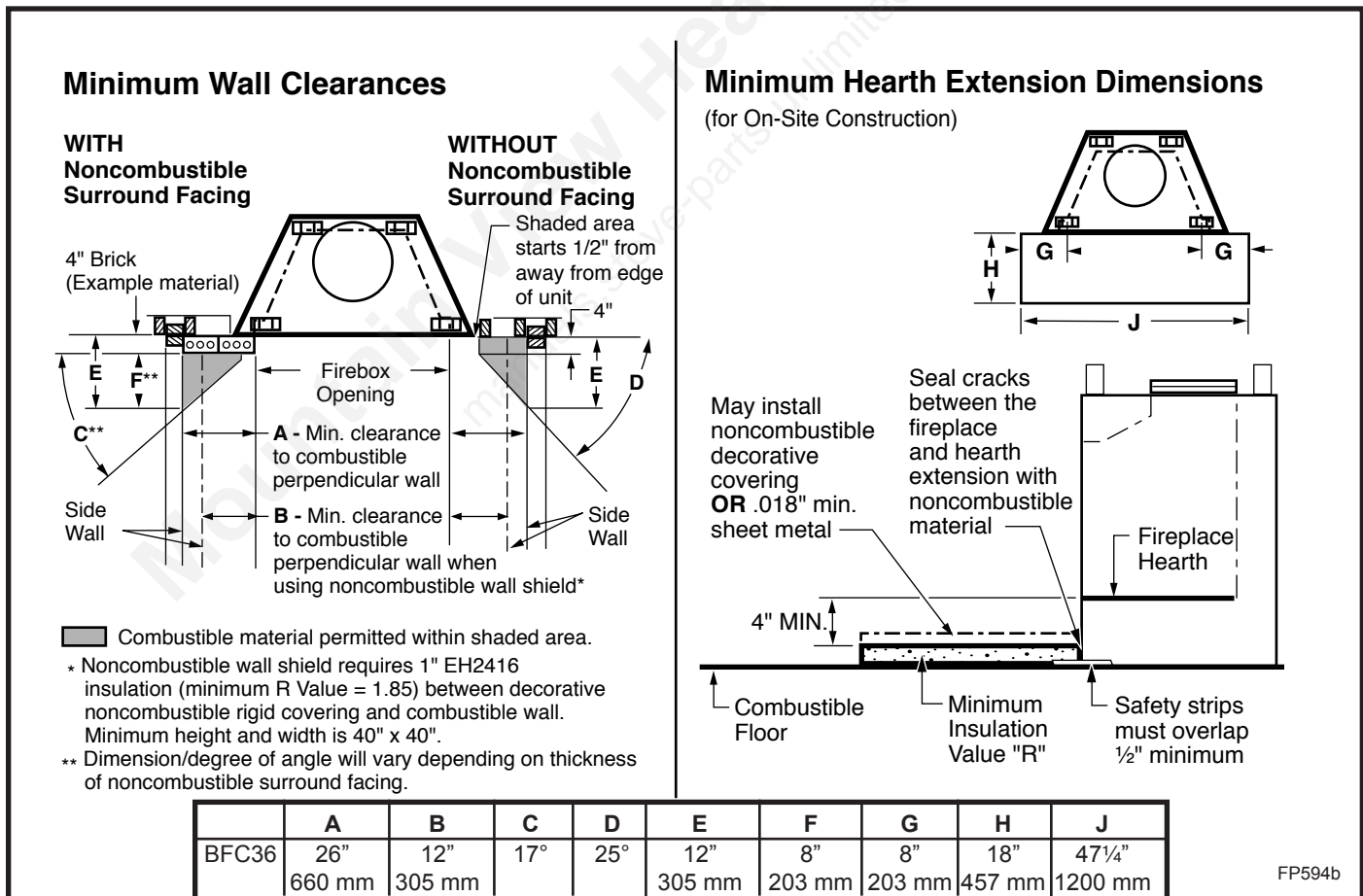

Fig. 21 Combustible side wall protection and hearth extension dimensions.

WARNING: Hearth extension must be installed in accordance with Figure 23 and must not cover the bottom front opening of the circulating model.

Alternate noncombustible materials may be used providing the (total) thermal resistance (Rt value) of the alternate material employed is greater than or equal to $R = 1.09$ Thermal resistance (R) or thermal conductivity (K), may be obtained from manufacturer of the material. Factors are related by the formula $K = 1/R$. (Fig. 24)

T = given thickness

R = thermal resistance for a given thickness (T)

K = thermal conductivity

Noncombustible material with a lower R value may be used, provided thickness of material is sufficiently greater to maintain an equivalent (total) thermal resistance (Rt).

COMMON MATERIALS AND FACTORS			
MATERIAL	K*	R	MINIMUM THICKNESS
EH2416 (MHSC)	0.458	1.09	0.50 in.**
Common Brick	5.0	0.10	5.46 in.**

R Value is for 1/2 inch.
 * Units of K = BTU/SQ FT/HR/°F/IN
 ** Thickness of Listed Material

FP533ADD

Fig. 22 Hearth extension material factors.

Example of Determining Hearth Extension Equivalents

To determine the thickness required for any **new** material:

$$\text{NEW required thickness} = \frac{\text{K of new material (per inch)}}{\text{K of listed material (per inch)}} \times \text{thickness of listed material}$$

Example for Common Brick

$T(\text{new}) = 5.0/0.458 \times 0.50 \text{ in.} = \mathbf{5.46 \text{ in.}}$ (new required thickness).

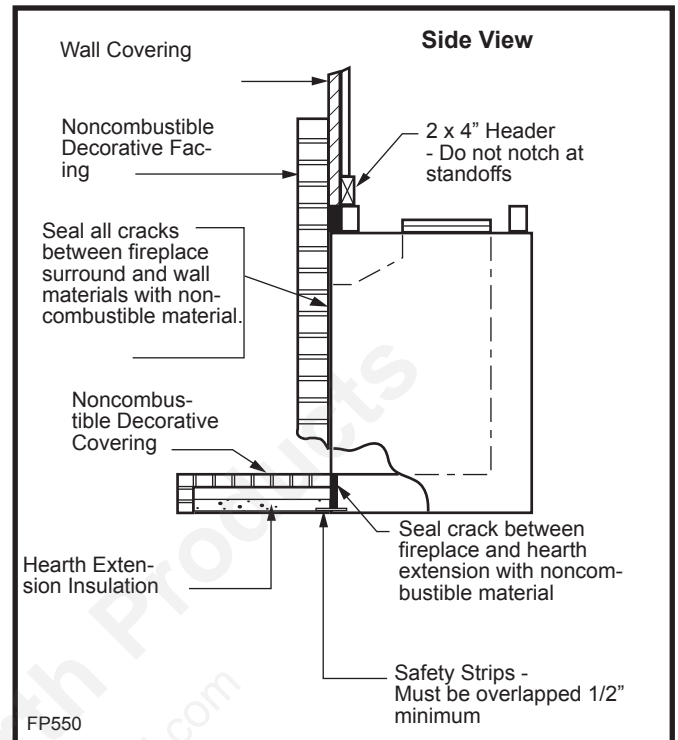

Fig. 23 Sealing gaps.

Glass Door Operation

The BFC36 is intended for use only with the doors fully closed. (Fig. 28)

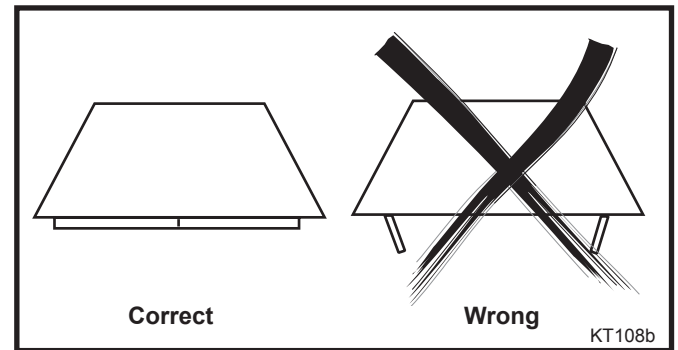

Fig. 28 Correct door position.

Operation

Before the first fire, the location of the upper refractory baffle (ceiling panel) should be checked. This part floats intentionally and may move out of place during shipping or installation of the fireplace. If the baffle is out of place, the resulting improper air flow will cause dirty glass and improper combustion. The baffle should be centered side-to-side between the refractory sidewalls and be pulled forward (toward the glass doors) until it rests on the front sheet metal ledge.

Refer to the publication "How to Enjoy Your Woodburning Fireplace" for starting and maintaining a wood fire.

Note that the BFC36 does not have a damper to open or close. This is a tremendous efficiency increasing advantage since there is no damper to potentially leave open after a fire dies down. House air will not escape up the chimney. Note also that the doors should remain closed at all times except when starting or reloading a fire.

Burn only seasoned firewood. Typically, only two or three burning logs are needed to provide efficient supplemental heat and a bright decorative fire. In general, fresh wood should not be loaded higher than about 2/3 the height of the firebox.

Installing Line for Gas Logs

MHSC fireplaces are designed to accept a 1/2" (13 mm) gas line for installation of an approved gas appliance. (MHSC manufactures a wide variety of gas logs for use in MHSC fireplaces.)

Be sure to have the appliance installed in accordance with building codes.

Gas connection may enter from either left or right side of the fireplace.

Locate appropriate gas line in the outer casing of fireplace and remove insulation from gas line tube. (Fig. 29)

From inside the fireplace, locate the knockout on the firebrick -- be sure you are on the appropriate or "gas line" side of the fireplace. Using a flat bladed screwdriver or small chisel and hammer, carefully tap around the knockout until it loosens and falls out.

Install 1/2" (13 mm) certified gas pipe through opening. After gas pipe installation is complete, use insulation that was removed from gas line tube to repack space around the pipe. Material should be inserted from outside of the fireplace and packed tightly to totally seal between the pipe and tube.

NOTE: Gas pipe should not come in contact with any wood structures until it has reached a point at least 1" (25 mm) away from fireplace side.

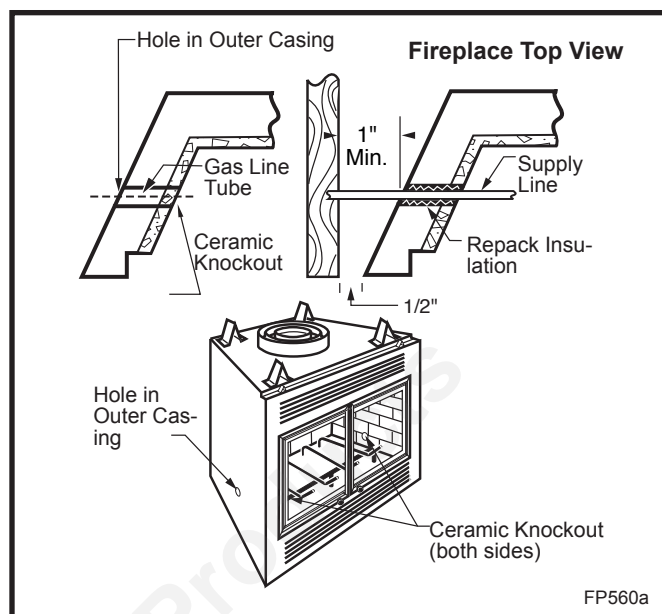

Fig. 29 Gas line access.

BTU input of a gas appliance installed in fireplace should be rated less than 100,000 BTU/Hr.

Gas pipe installation is intended for connection to a decorative gas appliance only when (1.) incorporating an automatic shutoff device and (2.) complying with the Standard for Decorative Gas Appliances for Installation in Vented Fireplaces (ANSI Z21.60) or CSA draft requirements for Gas-Fired Log Lighters for Woodburning Fireplaces (Draft No. 4, August 1993).

Decorative gas appliance should be installed in accordance with the National Fuel Gas Code, ANSI Z223.1/ NFPA 54 (latest edition).

CAUTION: When using decorative gas appliance, flue damper must be set in fully open position. Glass doors on the fireplace must also be fully opened.

WARNING: Do not operate an unvented gas log set in this fireplace with the chimney removed.

WARNING: When installing an unvented gas log set, the model CABL or CABR 4" adjustable hood must be used.

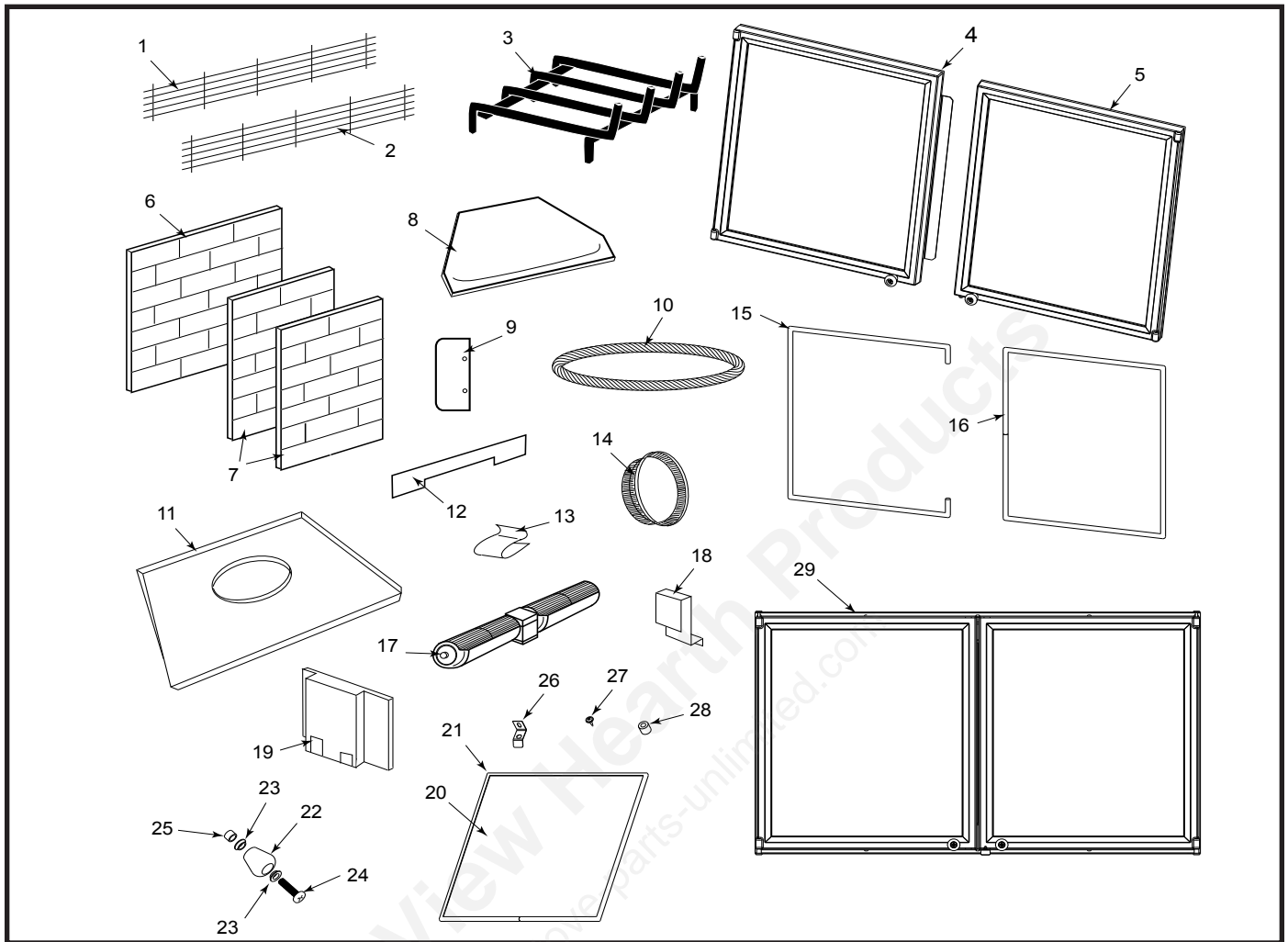

MHSC reserves the right to make changes in design, materials, specifications, prices and discontinue colors and products at any time, without notice.

BFC Balanced Flue Fireplace

Ref.	Description	BFC36
1.	Top Grille - Painted	3126160
2.	Bottom Grille - Painted	3126160
3.	Grate Assembly	7579218
4.	Left Door Assembly Complete	30004361
5.	Right Door Assembly Complete	30004362
6.	Rear Firebrick	2353145
7.	Side Firebrick (two per fireplace)	2353146
8.	Hearth Firebrick	2353140
9.	Nailing Flange (four per fireplace)	2422198
10.	Fiberglass Rope Gasket (Outer Collar)	7547137
11.	Top Refractory	2353147
12.	Front Brick Retainer	2353163
13.	Cable Clip (For Blower Assembly)	7522241
14.	Plug Button (two per fireplace)	7522239
15.	Left Door Gasket	20013999
16.	Right Door Gasket	20013998

BFC Balanced Flue Fireplace (continued)

Ref.	Description	BFC36
17.	Blower Assembly - FKSX-A	20000620
18.	Grate Retainer	2353179
19.	Junction Box Assembly	3126161
20.	Ceramic Glass Panel (two per fireplace)	30004352
21.	Flat Gasket 3/4" Wide (two per fireplace)	20013997
22.	Knob (two per fireplace)	1600657
23.	Bushing (four per fireplace)	1201895
24.	Pan Hd, PH 1/4-20 x 1 Black (two per fireplace)	1200907
25.	Spacer (two per fireplace)	1600070
26.	Spring Clip	30004450
27.	#8-18 x 1/2" Decorative Screw	7521180
28.	Hinge Spacer (two per fireplace)	30004360
29.	BFC Door Assembly	20014006

Accessories

The following accessories for this appliance are available from your local MHSC distributor. Should you need additional information beyond what your distributor can furnish, contact: MHSC, 149 Cleveland Drive, Paris, KY 40361, Attn: Technical Services.

CAUTION: This fireplace and chimney assembly is a highly engineered system, and, as such, must be operated only with MHSC approved components. If you use an unapproved component to make any modifications, you may create a possible fire hazard and will void the MHSC warranty. In addition, such action may void the coverage provided by the owner's insurance.

Accessory	Description	Model Number
Hearth Extension Insulation	Provides hearth extension floor protection	EH2416
Grate for BR/BC36/42	Holds firewood in firebox	RBG-BFC36
Hearth Patch Compound	Patch cracks in hearth	HPC-1

See your MHSC Fireplaces distributor or dealer for finishing Marble and Mantels, available in a wide selection of styles.

Chimney Components

Component	Description	Model Number
Chimney Support	Used to support chimney for each of 30' vertical height and 6' of angled chimney run	TCS8A (8" flue)
Firestop	Required at each floor level and attic on multi-story installation	FS2A (8" straight flue) FS6A (8" 30° inclined flue)
Attic Insulation Shield	Required in Canada	FS2100HT
Traditional Top Housing	Top housing of simulated brick pattern available in red, tan or white. Appropriate adapter is required (8CA). Flashing included.	T20B (single flue) TL20B (extra tall single flue)
Housing Extension	Extends Traditional Top Housing on steep pitched roofs	202036 (single flue)
Contemporary Chase Top Termination	Used to terminate chimney at the top of a chase. Flashing is not included. Adapter Kit (TT8CB) is required.	TT200C
Chase Top Housing	Used with chase terminations to prevent rain entry.	FL88 (8" flue)
Contemporary Flashing	Required for Contemporary Round Top termination to prevent rain entry.	8-6-12 with 8" flue 0 to 6/12 pitch 8-12-12 with 8" flue (6/12 to 12/12 pitch)
Chimney Sections	Used to build chimney systems.	8" flue 81 (1' long) 818 (1½' long) 83 (3' long) 84 (4' long)
Chimney Elbows	Used to develop offset chimney systems. Only 30° elbows are available. (Elbows packed 2 per carton - upper and lower elbow set.)	830A-2 (8" 30° flue)
Round Top Termination	Used to terminate chimney on the roof. Flashing not included.	RT8C (8" flue)
Extended Round Top Chase Termination	Used to terminate chimney at the top of a chase. Adapter Kit included. Flashing not included.	RT8CL (8" flue)
Adapter Kit	Required to connect triple-wall chimney with Traditional Top Housing (T20B or TL20B)	8CA (8" flue)
Adapter Kit	Required to unite chimney with Contemporary Chase Top. (TT200C)	TT8CB

LIMITED WARRANTY

Factory-Build Fireplace and Components (Except Blowers)

What is Covered and For How Long

Five-Year Coverage: For five years from the date this fireplace and components are first purchased for use, MHSC will, at its option, repair or replace any defective part of this fireplace or components, or refund to you a sum not to exceed the factory retail price in effect at the time of purchase.

Ten-Year Coverage: From the sixth through the tenth year following the date this fireplace or accessory is first purchased for use, MHSC will make available to you, at our factory, a free replacement for any defective part in this fireplace or accessory.

Twenty-Five-Year Availability of Replacement Parts: From the eleventh through the twenty-fifth year following the date this fireplace or accessory is first purchased for use, MHSC will make available at our factory replacement parts for this fireplace or accessory, which you may purchase for the list price current at the time your purchase order is received.

What is Not Covered

- This limited warranty does not cover:
- Transportation or shipping cost.
- The cost of a service call to diagnose trouble.
- Painted surfaces.
- Damage or defect caused by improper installation, accident, misuse, abuse or alteration.
- Poor ventilation of smoke or gases caused by air-conditioning and heating systems, exhaust fans, or pressure differentials produced by wind.
- Broken glass components.
- Cracks in ceramic and castable parts that do not affect safe operation.
- We do not warrant this fireplace to be in compliance with your local building code. Building codes vary greatly throughout the country, and you should determine whether your local building code contains restrictions on the use of this fireplace before you purchase it.
- Blowers or fans, which are warranted separately.
- Heat loss due to the passage of heat or air through or around the fireplace.

Also, under our five year coverage, we do not pay the cost of removal and replacement of any portion of the structure in which the fireplace is situated, made necessary by the repair, removal or re-installation of the fireplace.

And under our twenty-five year warranty of availability of replacement parts, we only promise to maintain a supply of replacement parts at our factory for you to purchase.

Limitations and Exclusions

1. No one has authority to add to or vary this limited warranty, or to create for MHSC any other obligations of liability in connection with this fireplace and accessory.
2. MHSC shall not be liable for incidental, consequential, special or contingent damages you might suffer as a result of its breach of this written warranty or any implied warranty. Some states do not allow the exclusion of limitation of incidental or consequential damages, so the above limitations may not apply to you.
3. This warranty applies only to a fireplace sold and used in the United States.

For information about this warranty, contact:

MHSC
149 Cleveland Drive
Paris, Kentucky 40361

Mountain View Hearth Products
manuals.stove-parts-unlimited.com

MHSC

149 Cleveland Drive • Paris, Kentucky 40361
www.mhsc.com