

INSTALLER:

THESE INSTRUCTIONS
MUST BE CONVEYED
TO AND REMAIN WITH
THE HOMEOWNER.

CERTIFIED UNDER CAN/
ULC-S610 - M87 and ULC
S627 / B366.2 FOR ZERO
CLEARANCE FIREPLACES
AND FREESTANDING
WOODSTOVE INSTALLA-
TIONS.



FIREPLACES

NZ2000

PRESTIGE ZERO CLEARANCE

OWNER'S MANUAL

INSTALLATION AND OPERATION

INSTRUCTIONS

25 YEAR LIMITED WARRANTY

Wolf Steel Ltd. warrants its NAPOLEON PRESTIGE FIREPLACE against manufacturing defects to the original purchaser only, subject to the following conditions:

1. Wolf Steel Ltd. will provide replacement parts free of charge during the first year of the Limited Warranty except plated finishes, glass, fibre seal, log retainer and refractory.
All repair work, however, requires the prior approval of an authorized company official. Labour costs for account of Wolf Steel Ltd. shall not exceed the retail price of the replacement parts.
2. Wolf Steel Ltd. will provide replacement parts during the second through the fifth year of the Limited Warranty free of charge except the plated finishes, glass, fibre seal, log retainer, refractory, grate and fan. Wolf Steel Ltd. will not be responsible for any labour costs in connection with those replacement parts.
3. Wolf Steel Ltd. will provide replacement parts (if available) at 50% of the retail price during the sixth through the twenty-fifth year of the Limited Warranty except the plated finishes, glass, fibre seal, log retainer, refractory, grate, and fan. Wolf Steel Ltd. will not be responsible for any labour costs in connection with those replacement parts.

Fireplaces are warranted only if protected from moisture with a raincap on top of the chimney. The manufacturer is not extending this Limited Warranty nor will he be responsible or liable, in any way, for damages or losses caused by, or arising from: accident, improper installation, handling or operation, abuse, poor maintenance or unauthorized repairs or changes made to the original design of the fireplace in question.

If you have to make a claim under this Limited Warranty, contact the dealer from whom you bought the unit or the manufacturer. You will have to pay for shipping and inspection charges. All parts are F.O.B. Barrie, Ontario.

IMPORTANT: KEEP THE ORIGINAL INVOICE SINCE A PHOTOCOPY OF IT WILL BE REQUIRED IN CASE OF CLAIM.



MANUFACTURED BY: WOLF STEEL LTD., R.R.#1 BARRIE, ONTARIO, CANADA, L4M 4Y8 (705)721-1212, FAX (705)722-6031.

WS- 415-29 / 02.16.94

TABLE OF CONTENTS

Pg. 2	Introduction	Pg. 9	Caution
3	General Notes	10	Control of Burning Rate
4	Location		Paint
	Framing		Airwash
5	Optional Fan Installation		Wood
	Outside Combustion Air		- Disposal of Ashes
6	Heat Exchanger - Hot Air Outlets	11	Creosote Formation and the Need for Removal
	Hearth Extension		Smoking and Back-Puffing
	Chimney Installation		Maintenance
7	Adding Chimney Sections		Chimney
	Offset Chimney Installations		Fireplace
8	Table of Typical Installation	12	Glass Care
	Installing Flashing and Storm Collar		Brass and 24K Gold Plated Parts
9	Attaching the Handle		Do's and Don'ts
	Operating Instructions		



FIREPLACES INTRODUCTION

Your new fireplace is a highly efficient air-tight heater that will give you many years of service and comfortable heat. To ensure safe, correct installation, proper operation and maintenance, be sure to read these instructions before installing the fireplace. Failure to do so could result in a serious hazard.

This fireplace was tested to CAN/ULC S610 - M87 Zero Clearance Fireplace Safety Test Standard as well as ULC S-627/B366.2 in accordance with freestanding woodstove installations. In accordance with this standard, the unit may be connected to any accepted high temperature chimney system listed to ULC S-629.

The following Canadian 7" chimney systems may be used:

NOTE: A fireplace adaptor or anchor plate may be required if the chimney used is other than Oliver Macleod HT-3103.	OLIVER MACLEOD	Model HT-3000 or HT-3103
	SECURITY	Model ASHT or S-2100
	GSW	Model SUPER CHIMNEY 21
	RYDER	Model COMMANDER 5000 or HT 3103
	SELKIRK METALBESTOS	Model SENTINEL CF-3

All clearances to combustible framing and venting connection must be in compliance with the chimney manufacturers installation instructions or as noted in these instructions.

Clearances referred to throughout this manual are the minimum requirements.

The ULC S-627 Woodstove Safety Standard provides for almost unlimited installation versatility. It should be noted, however, that performance will diminish as offsets are added. The ideal installation is as direct and vertical as possible.

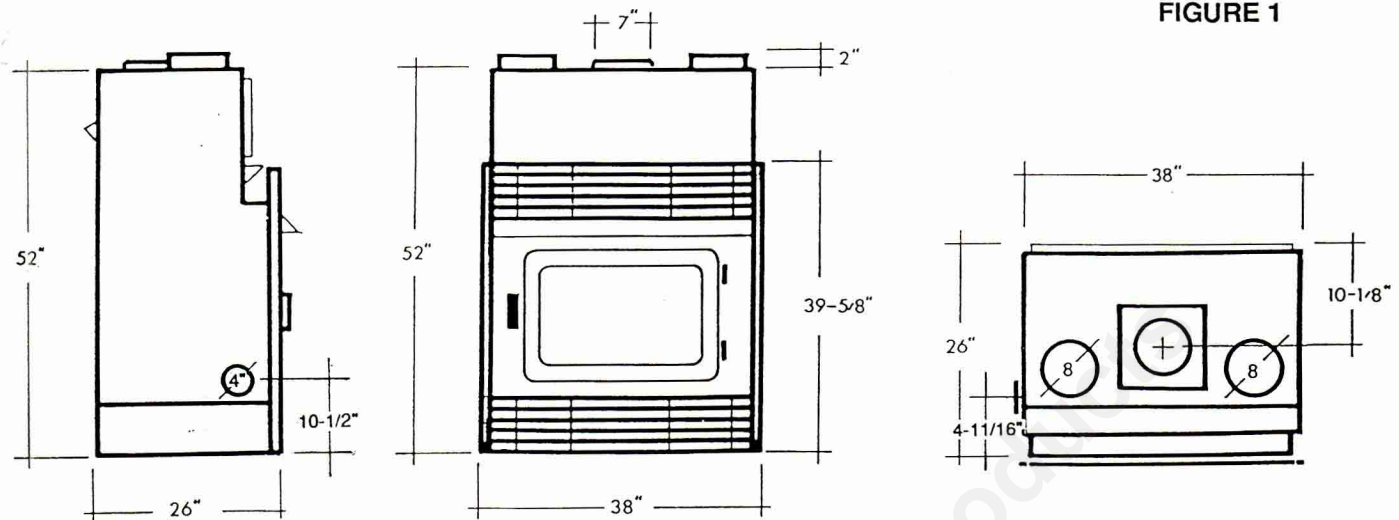

Consult the authority having jurisdiction (such as municipal building department, fire department, fire prevention bureau, etc.) to determine the need to obtain a permit.

If you are in doubt about proper installation in your situation, contact your dealer, local building or fire official.

Your Napoleon fireplace must be installed in accordance with all national and local building code standards and the standard of Chimney and Fireplaces, Vents and Solid Fuel Burning Appliances NFPA No. 211.

THESE INSTRUCTIONS MUST BE FOLLOWED EXPLICITLY. FAILURE TO DO SO MAY RESULT IN HAZARDOUS CONDITIONS.

DO NOT USE MAKESHIFT COMPROMISES DURING INSTALLATION.

GENERAL NOTES

The fireplace must be installed against finished walls. Do not install against a vapour barrier or exposed insulation.

The fireplace can be built directly on the floor or on a raised hearth. A non-combustible hearth extension is required and must not be built higher than the bottom of the fireplace to avoid blocking the air flow.

Keep furnishings and combustibles well away from the fireplace.

The fireplace must only be operated with the doors fully closed or with the optional Napoleon firescreen (Keep the ashpan door closed during operation).

The minimum distance between the edge of the fireplace and adjacent walls at right angles to the fireplace is 14 inches (Figure 2).

Maintain adequate clearances from combustibles, above and in front of the hot air grilles.

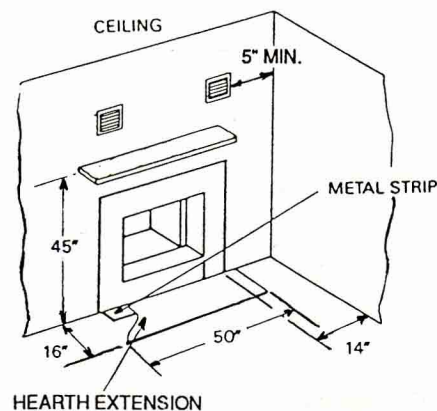

LOCATION

DO NOT INSTALL INTO ANY AREA HAVING A HEIGHT FROM CEILING TO UNIT BOTTOM OF LESS THAN 7 FT. (EXCLUDING HEARTH HEIGHT). The most desirable and beneficial location for a Napoleon Fireplace is in the centre of a building, thereby allowing the most efficient use of the heat created. The location of windows, doors and the traffic flow in the room where the fireplace is to be located should be considered. If possible, you should choose a location where the chimney will pass through the house without cutting floor or roof joist.

A wall projecting at 45° from the outer edge of the fireplace is allowed. Projections into the shaded area are permitted (Figure 3).

Fireplace minimum clearances to combustibles are as follows:

Fireplace as per standoffs 0" to floor, sides and back
 Chimney above ceiling level . . 2" *
 Chimney below ceiling level . . 2" * on 2 adjacent sides
 and as determined by
 the top profile of the
 fireplace.

* Oliver Macleod chimney model HT-3103 only: minimum clearance is 2-3/4"

DO NOT FILL THIS SPACE WITH ANY MATERIAL (Figure 3).

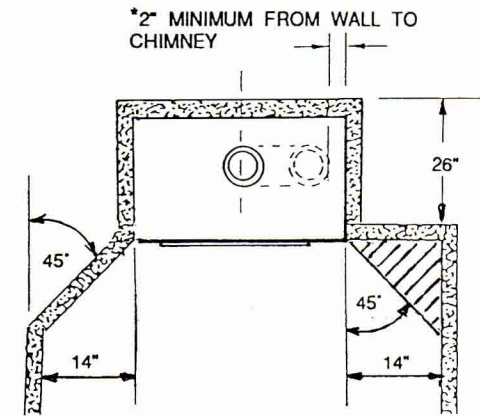
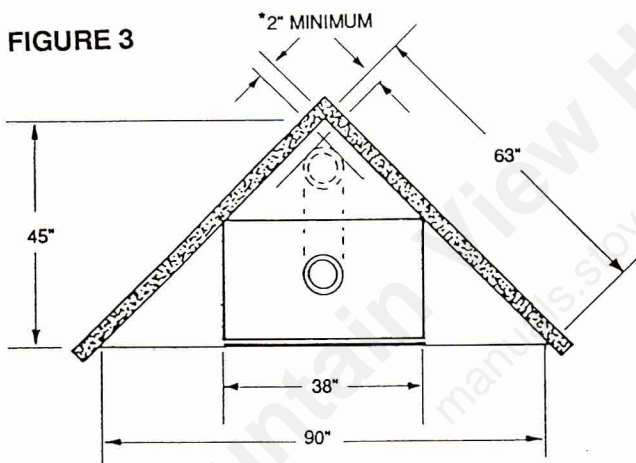

FIGURE 3



FRAMING

Do not place insulation into the space around the fireplace or the chimney. Placed in this space, it may cause the adjacent wood to overheat and catch on fire.

The fireplace should be framed using 2 x 4 lumber (Figure 6). Combustible materials must be installed flush with the front of the fireplace but must not cover any of the black face-area of the fireplace (Figure 2, 6, 9). Non-combustible material (brick, stone or ceramic tile) may protrude.

Do not build shelves or cupboards into the area above the fireplace. Combustible material within this area could overheat.

If the ceiling height is less than 8 feet, but not less than 7 feet, use Napoleon ceiling shield NZ95. A ceiling shield is not required with any 2" wall Canadian high temperature chimney listed to ULC S-629.

If a mantel made of combustible materials is installed, it must be a minimum of 45" above the base of the fireplace (Figure 4).

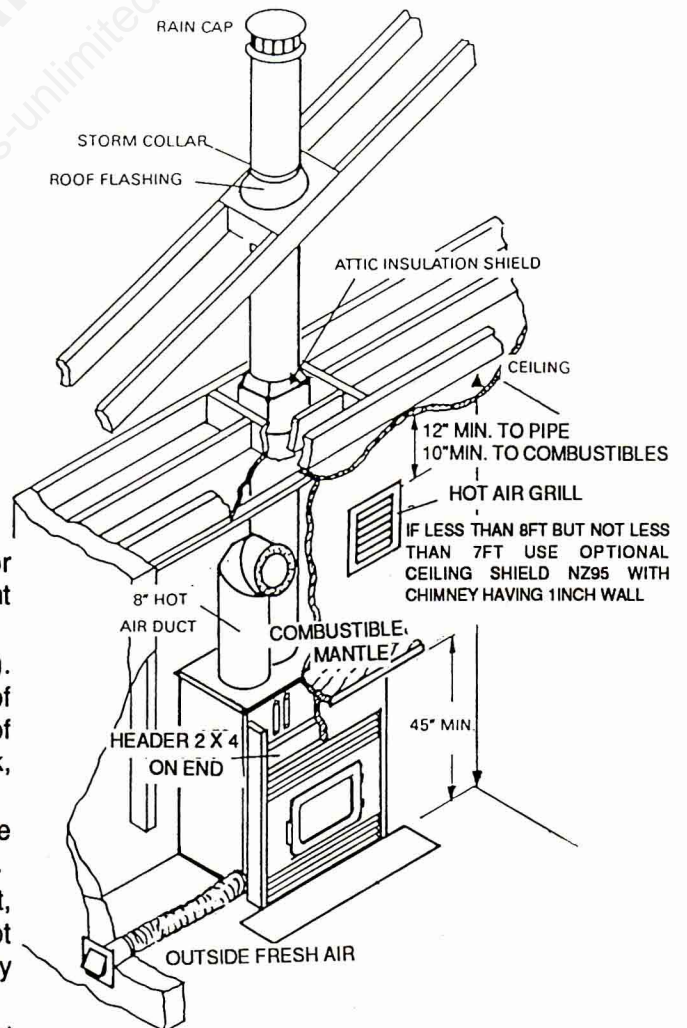

GENERAL INSTALLATION VIEW
 FIGURE 4

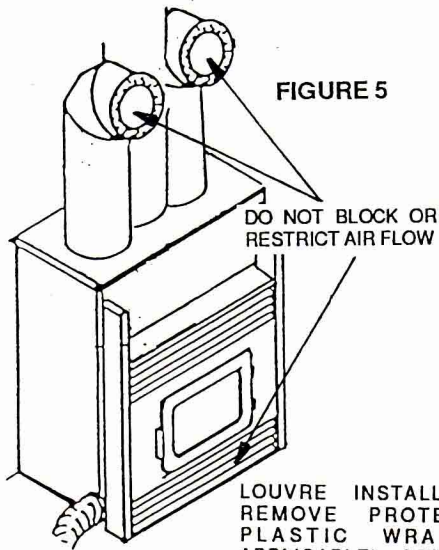

FIGURE 5

DO NOT BLOCK OR RESTRICT AIR FLOW

LOUVRE INSTALLATION:
REMOVE PROTECTIVE
PLASTIC WRAP (IF
APPLICABLE) PRIOR TO
OPERATING THE FIREPLACE

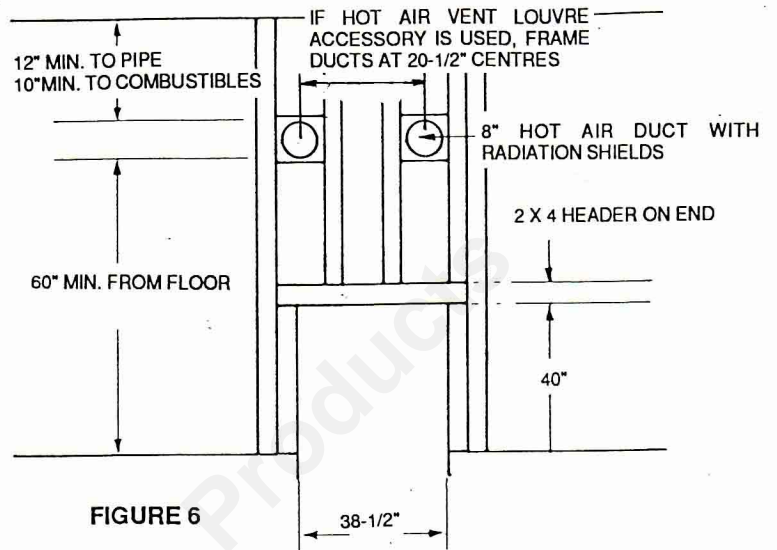

FIGURE 6

OPTIONAL FAN INSTALLATION

Use Napoleon fan kit #NZ 130KT (For location see Figure 7). If the optional fans are to be installed, make provisions at this time by routing a 110 volt power line to the fireplace. The variable speed switch that controls fan speed can be installed on a room wall. Detailed installation instructions are included with the fan kit.

OUTSIDE COMBUSTION AIR

CAUTION: This fireplace takes outside air directly into the firebox through the opening on the left hand side. Make sure if not using an outside air kit that the opening is not obstructed and enough air is supplied at all times to this outlet.

If the optional fresh air kit is installed, it must not draw air from the attic, or the garage. The fresh air must come from outside the house.

The maximum length of the 4 inch air duct is 20 feet; after 20 feet enlarge the duct to a 6 inch diameter.

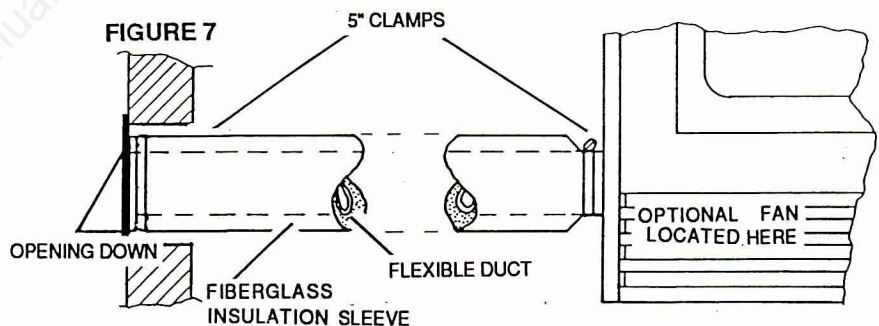

FIGURE 7

5" CLAMPS

OPENING DOWN

FIBERGLASS
INSULATION SLEEVE

FLEXIBLE DUCT

OPTIONAL FAN
LOCATED HERE

1. Decide on the most convenient location for the fresh air inlet duct and register. The duct and register may be installed above or below floor level.
2. Make a 5 inch hole in an outside wall of the house. From outside, place the outside air register into the hole, open side down.
3. At each end, carefully pull back the insulation sleeve exposing the flexible duct (Figure 7). Place the insulated flexible duct over the register tube and over the fireplace outside air connector. Carefully push the insulation sleeve back over the duct. Using the clamps, fasten the insulated flexible duct into place on both sides.

Always provide a source of fresh air into the room in which the fireplace is installed. Failure to do so may result in air starvation of other fuel burning appliances and the possible development of hazardous conditions. The optional Fresh Air Kit is available from your Napoleon / Wolf Steel Ltd. dealer.

HEAT EXCHANGER - HOT AIR OUTLETS

Use only approved hot air grills designed for the Napoleon NZ2000, available from your authorized Napoleon dealer. **DO NOT BLOCK OR RESTRICT AIR OPENINGS.**

The outlets must be connected and are to be built with an incline to permit the free flow of hot air from the heating unit. The outlets are to be a minimum 8" diameter. Insulated aluminum flex pipe and radiation shields are provided. A minimum 2" clearance to combustibles must be maintained from the flex pipe or 1" from the insulated sleeve.

Install the hot air ducts in an **upward direction only**. Never install in a downward direction. The hot air ducts may extend through the floor to a room above but must be located a minimum of 60 inches above the floor, and placed vertically against a wall to permit horizontal heat discharge. The maximum hot air duct length is 10 feet.

To install the hot air grills or vent louvres, cut and frame 2 openings, 12" square, and at least 10" from the ceiling or nearest combustible. For the hot air vent louvres, frame these openings at 20-1/2" (center to center) (Figure 6, 8). Install the 2 radiation shields, supplied with the fireplace. Cover the hot air duct pipes with the insulation sleeve provided. **Do not compress.** Secure with 4 screws each to the fireplace and the radiation shields, maintaining a 1" clearance to the non-compressed insulation sleeve. Mount the hot air grills or vent louvres to the finished wall.

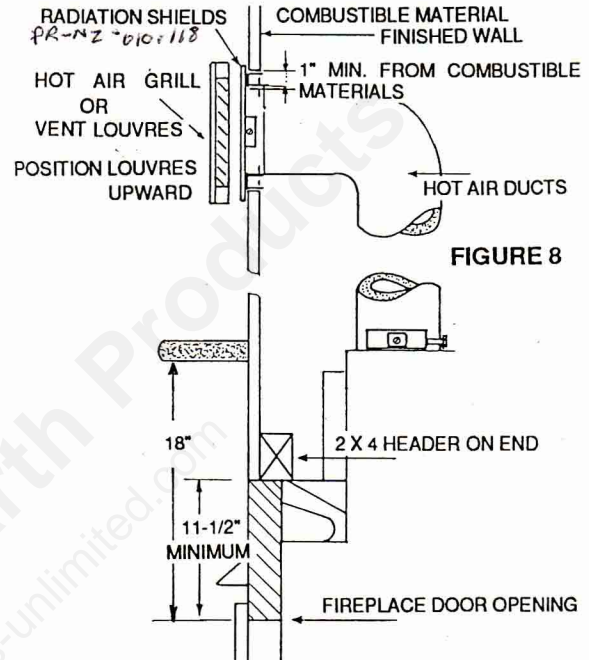

HEARTH EXTENSION

A 16 x 50 inch non-combustible hearth extension (ie: brick, stone or ceramic tile) must be installed. Be sure that the joint between the fireplace and the hearth extension is sealed with a sand-cement grout to prevent sparks or embers from falling into this area. A raised hearth together with a hearth extension is recommended for easier wood loading and fire viewing.

CHIMNEY INSTALLATION

A chimney venting a fireplace shall not vent any other appliance. The minimum overall chimney height from the top of the fireplace is 15 feet. If the chimney extends higher than 5 feet above the roof, it must be secured using a roof brace or guide wires. The chimney must be supported at a maximum of 20 ft intervals (approximately 200 lbs).

A raincap must be installed on top of the chimney; failure to do so may cause the fireplace to corrode.

If the ceiling height is less than 8ft. but not less than 7ft., a ceiling shield must be installed (Figure 9). This shield is not required with any high temperature chimney listed to ULC S-629.

Factory built chimneys that extend past the story on which the fireplace is located must be provided with enclosures that have a fire resistance rating equal to or greater than that of the floor or roof assemblies through which they pass. This does not apply to installations in single or two-family dwellings.

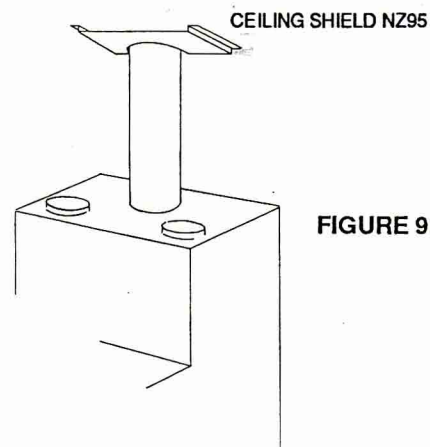

FIGURE 9

Portions of the chimney that extend through accessible spaces must always be encased to avoid personal contact with the chimney and thereby damage the chimney (BE SURE TO MAINTAIN MINIMUM CLEARANCES REQUIRED).

The chimney should not be built with an offset angle to the heat exchanger in excess of 45°.

BEFORE INSTALLING, REMOVE THE SIDE TRIM AND THE 2 PIECE HOOD FROM THE UPPER RIGHT AND LEFT HOT AIR DUCTS.

1. Move fireplace into position. Try to center the exhaust of the fireplace, midpoint between two joists to prevent having to cut them. Use a plumb bob to line up the centre.
2. Cut and frame an opening in the roof to provide 2" clearance between the outside of the chimney and any combustible material. DO NOT FILL THIS SPACE WITH ANY TYPE OF MATERIAL. Nail headers between the joist for extra support. Firestop spacers must be placed on the bottom of each framed opening in any floor or ceiling that the chimney passes through (Figure 10).
3. Hold a plumb bob from the underside of the roof to determine where the opening in the roof should be. Cut and frame the roof opening to maintain proper 2" clearances (Figure 11).

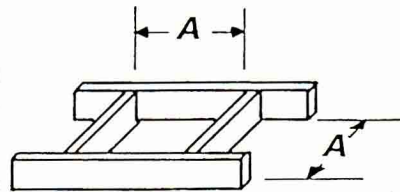
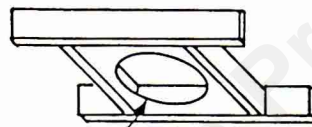

FIGURE 10



FIRESTOP SPACER LOCATED ON UNDERSIDE OF JOIST

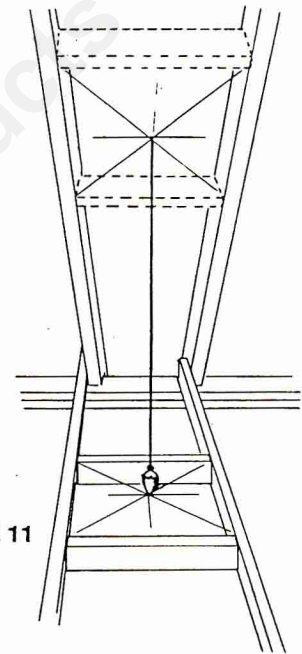

FIGURE 11

* Oliver Maclod chimney model HT-3103 only: minimum clearance is 2-3/4"

ADDING CHIMNEY SECTIONS

Add chimney sections, twist locking (clockwise) securely, to the required height. The chimney must extend, at least, 3 feet above its point of contact with the roof and at least 2 feet higher than any wall, roof or building within 10 feet (Figure 12). If your chimney system is enclosed within the attic area, a rafter radiation shield is required.

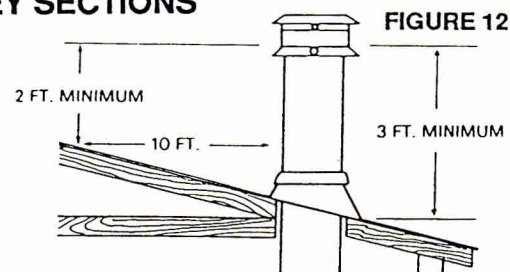

FIGURE 12

OFFSET CHIMNEY INSTALLATIONS

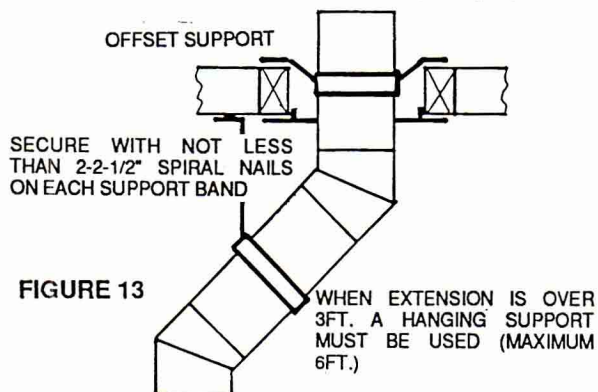

FIGURE 13

An insulated elbow must be used when it becomes necessary to offset the chimney in order to clear a joist or pass through an upstairs closet.

Attach an elbow to the chimney section, angled toward the offset. Secure with 3 - #8 X 1/2" sheet metal screws. To achieve the minimum offset, attach and secure a return elbow to the first. To achieve longer offsets, you may install 12", 24", or 36" lengths of chimney pipe between the elbows.

Supports must be used on the first vertical chimney section after a return elbow (Figure 13).

The maximum offset angle to the heat exchanger that may be used is 45° in Canada and 30° in USA.

TYPICAL INSTALLATION	STRAIGHT UP (Figure 14)	OFF-SET (2 ELBOWS) (Figure 15)	OFF-SET (4 ELBOWS) (Figure 16)
CHIMNEY MINIMUM HEIGHT (FT.)	15 FT. MIN.	15°-15 FT. MIN 30°-15 FT. MIN *45°-15 FT. MIN	15°-15 FT. MIN 30°-15 FT. MIN *45°-15 FT. MIN
RAFTER RADIATION SHIELD	YES	YES	YES
ATTIC INSULATION SHIELD	YES	YES	YES
FIRESTOP SPACER ASSEMBLY	-	YES	YES
INTERIOR OFF-SET SUPPORT	-	YES	YES
VENTED ROOF FLASHING WITH STORM COLLAR	YES	YES	YES
RAIN CAP	YES	YES	YES

* CANADA ONLY

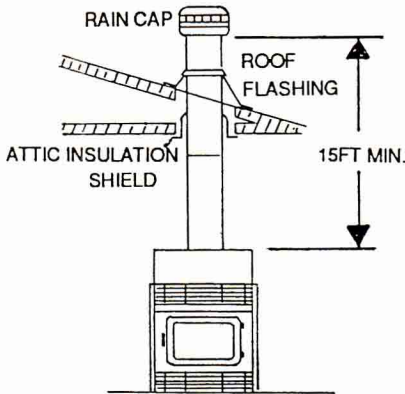

FIGURE 14: TYPE 1

No off-set. Min. overall chimney height is 15 ft.

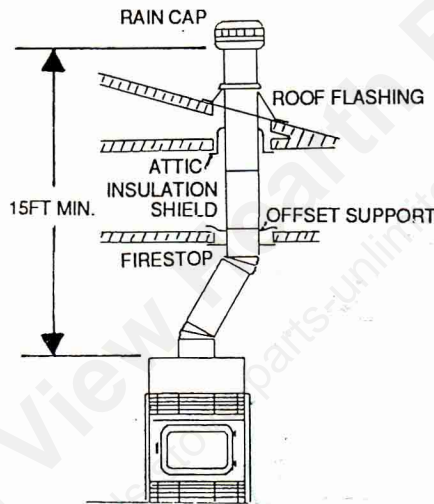

FIGURE 15: TYPE 2

Single off-set with two 15°, 30°, or 45° elbows. Min. overall chimney height is 15 ft.

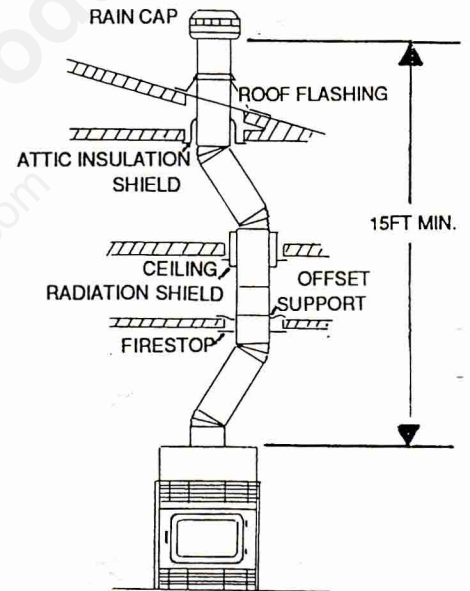

FIGURE 16: TYPE 3

Double off-set with four 15°, 30° or 45° elbows. Min. overall chimney height is 15 ft.

INSTALLING FLASHING AND STORM COLLAR

Remove nails from the shingles above and to the sides of the chimney. Place the flashing over the chimney pipe and, slide it underneath the sides and upper edge of shingles. Ensure that the chimney pipe is properly centered within the flashing, giving a 3/4" margin all around. Fasten to the roof on the top and sides. DO NOT NAIL through the lower portion of the flashing. Make weather-tight by sealing with caulking. Where possible, cover the sides and top edges of the flashing with roofing material.

Apply waterproof caulking, provided with the flashing, around the chimney, 1" above the top of the flashing and push the storm collar down into the caulking (Figure 17).

Insert a rain cap onto the top of the last chimney section.

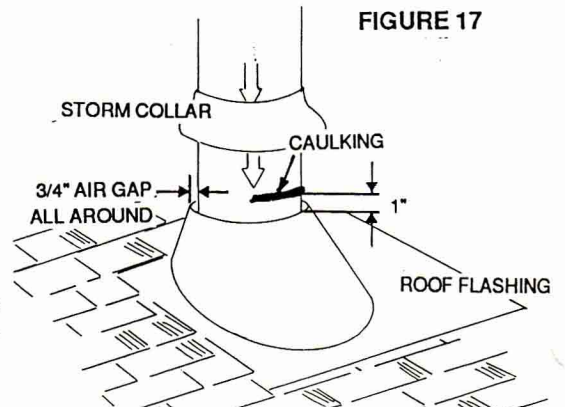
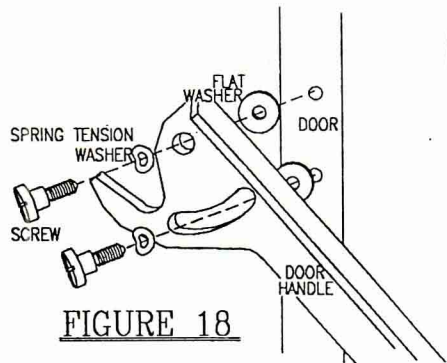
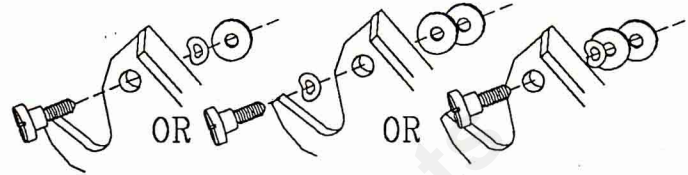

FIGURE 17

ATTACHING THE HANDLE



Attach the handle as shown so that when the door is closed, the handle will be centred in the slot located on the fireplace front. To achieve this you may have to experiment (on the upper and lower screws) with one of the variations shown. Tighten securely.



IMPORTANT OPERATING INSTRUCTIONS FOR THE HOMEOWNER

Your Napoleon fireplace is a Hi-Tech unit, designed with the most advanced technology. The unit is very airtight and has exclusive direct outside air supply -- a safety feature designed to prevent spillage and to keep your house free of carbon monoxide in case of a downdraft or negative inside pressure. You will observe that the fire in your Napoleon fireplace burns differently than conventional fireplaces. The slow and lazy yet constant flames, large heat radiating glass surface and hot air circulation all work together to *return heat to your home*. A roaring fire, common to old fashioned wood burning appliances simply discharges a high volume of wasted heat energy up the chimney.

CAUTION

- Burn wood only.
- Build your fire on the hearth and behind the log retainer only.
- Never use gasoline, gasoline-type lantern fuel, kerosene, charcoal lighter fluid, or similar liquids to start or "freshen up" a fire. Keep all such liquids well away from the fireplace while in use.
- Always provide a SOURCE OF FRESH AIR FOR THE FIREPLACE.
- Always provide a SOURCE OF FRESH AIR FOR THE FIREPLACE.
- Keep the door of the fireplace closed during operation or fully open with the optional Napoleon firescreen.
- Combustible materials are not to be stored within 48" of the fireplace.
- Protect the chimney from moisture with a raincap.
- Contact with radiant surfaces may cause skin burns.

This fireplace was designed for burning solid fuel (e.g. wood, charcoal). You should not burn highly volatile fuels (e.g. paper, cardboard, gasoline, wax). Do not overfire. Keep fires away from the door and behind the log retainer.

Do not block or restrict the hot air vents or air inlets in the fireplace. This will cause the fireplace to overheat.

Do not operate the fireplace with the ashpan door open.

PLEASE FOLLOW THESE DIRECTIONS CAREFULLY:

Open the air control fully by sliding the lever to the right.

During the break-in period (the first 2 to 3 fires) maintain only small fires using kindling; this will allow the firebrick to "cure". Do not be alarmed if small hairline cracks develop in the firebrick. This is a normal occurrence and does not pose a safety hazard.

Slowly add larger wood (2x4 inch size) crisscrossing them over the fire. When the fire seems to be at its peak, medium sized logs may be added. Once the larger logs have caught fire properly, carefully close the door. *Closing the door too quickly after re-fueling will reduce the firebox temperature and result in an unsatisfactory burn.* Remember, it is more efficient to burn medium sized wood briskly, and re-fuel frequently rather than load the fireplace with large logs resulting in a smouldering fire and dirty glass.

As soon as the door is closed, you will observe a change in the flame pattern. The flames will get smaller and "lazier" because less oxygen is allowed into the combustion chamber but they will become more efficient and larger again as soon as the firebricks have been heated properly and the heated chimney provides a good draft. The roaring fire that you see when the door is open is wastefully drawing heated room-air up the chimney. *Certainly not desirable.* So always operate the unit with the door fully closed.

You can now add larger pieces of wood and operate the fireplace normally.

Regulate the temperature by sliding the air control lever to the left. The flames will moderate and generate less heat. Allow several minutes for the fire to stabilize after adjustment.

NOTE: WHEN FIRST LIGHTING A FIRE, IF THE SMOKE IS NOT QUICKLY DRAWN INTO THE CHIMNEY, THERE MAY BE A DOWNDRAFT OR COLD AIR IN THE CHIMNEY. ROLL UP SOME NEWSPAPER, LIGHT IT AND PLACE IT INTO THE FIREPLACE FLUE UNTIL THE CHIMNEY BEGINS TO DRAW. DURING A FIRING, OPEN THE AIR CONTROL BEFORE OPENING THE FIREPLACE DOOR. OPEN THE DOOR SLOWLY TO AVOID DRAWING SMOKE INTO THE ROOM.

CONTROL OF BURNING RATE

Because your fireplace is airtight, the only air intake will occur through the air inlet on the left side of the fireplace. The air inlet can be opened and closed by way of the air control lever located below the fireplace door. To open the air control, move the lever to the right. To close it, move the lever to the left. Once the fire is started and well underway, you can control the burning rate by adjusting the lever. Opening the control will cause the fire to burn more vigorously; closing it, to burn slower. Never operate the fireplace with the ashpan door open.

PAINT

When you first use your fireplace, the high temperature paint that is used on the surface of the fireplace will smoke a little and give off an odour for several hours. This condition is temporary. Open the doors and windows to ventilate the room(s) sufficiently.

AIRWASH

The air intake directs air over the glass and into the fire. This will keep the 'fire viewing' window clean for longer periods of time. Build-up on the glass depends also on what type of wood is used, on the burning rate and on the draft of the chimney.

WOOD

Wet or unseasoned (green) wood is not recommended for use. It still contains a lot of moisture and therefore is heavier and harder to ignite, holding less energy, burning inefficiently, smoking more and clogging your chimney system with creosote --a tar-like **flammable** substance.

For these reasons, only hardwood that has been seasoned for several months should be used as fuel. Ideally, firewood should be cut, split and piled one heating season ahead. All dry wood has the same BTU factor per pound. Hardwood, however, (i.e. oak) is a denser wood and takes less space than softwood (i.e. pine). Therefore, one cord of oak has a higher energy value than one cord of pine. Hardwood burns longer and creates less creosote.

To store your wood, stack it so that both ends of the logs are exposed to air. Cover the top of your woodpile with plastic, scrap plywood, etc. Also stack firewood on smaller pieces of wood or similar items to allow air to circulate underneath.

DISPOSAL OF ASHES

Ashes should be placed into a metal container with a tight fitting lid. The closed container of ashes should be placed on a non-combustible floor or outside on the ground, well away from all combustible materials, pending final disposal. If the ashes are disposed of by burial in the soil or otherwise locally dispersed, they should be retained in the closed container until all cinders have thoroughly cooled.

For your convenience an ashpan complete with lid is included with this fireplace.

CREOSOTE - FORMATION AND THE NEED FOR REMOVAL

When wood is burned slowly, it produces tar and other organic vapours, which combine with expelled moisture to form creosote. The creosote vapours condense in the relatively cool chimney flue of a slow burning fire. As a result, creosote residue accumulates on the flue lining. When ignited, this creosote residue becomes an extremely hot fire.

A slow burning or smouldering fire should not be maintained for any extended period of time. Periodically during the day build a hot fire to increase the flue temperature and reduce creosote accumulation. Deposits of creosote restrict the opening of the flue, interfere with your draft and can lead to a chimney fire.

In case of a chimney fire, which may produce a roaring sound and cause sparks to fly from the chimney, close the air control (and the door) immediately. Let the fire go out. Have your chimney inspected for any structural damage by someone knowledgeable.

The chimney should be inspected at least once every two months during the heating season to determine if a creosote build-up has occurred.

If creosote has accumulated, it should be removed to reduce the risk of a chimney fire.

Avoid the use of green, unseasoned wood or wood with high pitch content. Do not operate the fireplace in a choked down position over an extended period of time.

SMOKING AND BACK-PUFFING

If your fireplace smokes after the chimney has warmed up, it is caused by insufficient draft of the flue system.

Check for the following:

- | | |
|---------------------------------------|---|
| 1. Insufficient combustion air. | 7. Downdraft created by |
| 2. Creosote build-up. | - blockage of the chimney outlet. |
| 3. Clogged chimney system. | - chimney installed on the leeward side of an obstruction. |
| 4. Clogged spark arrestor. | |
| 5. Too many turns in the flue system. | 8. Chimney pipe on the outside of the house cools too fast resulting in insufficient draft. |
| 6. Chimney not high enough. | 9. Porous masonry chimney. |

MAINTENANCE

Use only Napoleon replacement parts. Do not use substitute materials.

CHIMNEY

Check your chimney frequently for creosote and soot build-up. If the accumulation is excessive, clean the chimney. You might want to call a professional chimney sweep to have this done. The chimney must be cleaned once a year or as often as necessary.

FIREPLACE

Inspect the fiberglass rope on the door and around the ceramic glass from time to time for proper seal. Air leakage resulting from poorly sealing gaskets decreases the efficiency of your stove. A 1/2" door gasket and U-gasket is available from your Napoleon / Wolf Steel Ltd. dealer.

If you want to refinish your fireplace to its original good looks, use a quality high heat aerosol paint which is also available from your Napoleon / Wolf Steel Ltd. dealer. Before spray-painting the fireplace, remove any parts that you do not want painted. Rough up the existing paint with fine sandpaper or steel wool. Follow the directions on the paint can. Do not paint the fireplace when hot.

GLASS CARE

Ceramic glass is used as the fire-viewing window of your Napoleon Fireplace. Ceramic glass has well established and recognized heat resistance and strength characteristics. It can only be broken through improper use or impact. Do not slam the fireplace door or otherwise impact the glass. When closing the door, make sure that no logs or other objects protrude to impact against the glass.

Do not clean the glass with materials which may scratch or otherwise damage the glass. Scratches on the glass can develop into cracks and breaks. Non-abrasive cleaners are available from your dealer. Never attempt to clean the glass while it is hot. Never put substances which can ignite explosively in the stove since even small explosions in confined areas can blow out the glass. Inspect the glass regularly for cracks and breaks. If you find any, extinguish the fire immediately and return the door, which unhinges easily, to your Napoleon / Wolf Steel Ltd dealer for glass replacement before further use. Tempered or ordinary glass will not withstand the high temperatures. Use only 3/16 (5mm) thick ceramic glass as a replacement.

BRASS AND 24 KARAT GOLD PLATED PARTS

Your fireplace may be highlighted by brass or gold plating. Do not use abrasive cleaners to clean these parts. Buff lightly with a clean dry cloth.

DO:

1. BUILD A HOT FIRE.
2. USE ONLY DRY WOOD.
3. SEVERAL PIECES OF MEDIUM SIZED WOOD ARE BETTER THAN A FEW BIG PIECES.
4. REFUEL FREQUENTLY USING MEDIUM SIZED WOOD.
5. 'FINE TUNE' THE AIR SETTINGS FOR OPTIMUM PERFORMANCE.
6. CLEAN CHIMNEY REGULARLY.

DON'T:

1. TAKE ASH OUT IMMEDIATELY. LET IT ACCUMULATE TO AT LEAST ONE INCH IN DEPTH. A GOOD LAYER OF ASH PROVIDES FOR A LONGER LASTING AND BETTER BURNING FIRE.
2. BURN WET WOOD.
3. CLOSE THE FUEL DOOR TOO SOON OR DAMPER DOWN TOO QUICKLY.
4. BURN ONE LARGE LOG RATHER THAN 2 OR 3 SMALLER, MORE REASONABLY SIZED ONES.
5. BURN AT CONTINUALLY 'LOW SETTING'. IF THE GLASS DOOR IS CONSTANTLY BLACKENED, THE FIREBOX TEMPERATURE IS TOO LOW.