

INSTALLER : THESE INSTRUCTIONS MUST BE CONVEYED TO AND REMAIN WITH THE HOMEOWNER.

CERTIFIED IN CANADA TO CAN/CSA C22.2 NO. B140.3, B140.1, B140.0 AND IN THE UNITED STATES CONFORMS TO UL Std 307a, ANSI/ULStd 896



**INSTALLATION AND OPERATION INSTRUCTIONS
FOR
OIL-FIRED CAST IRON STOVE
MOBILE HOME APPROVED**

**MODEL
SAVOY OS11**

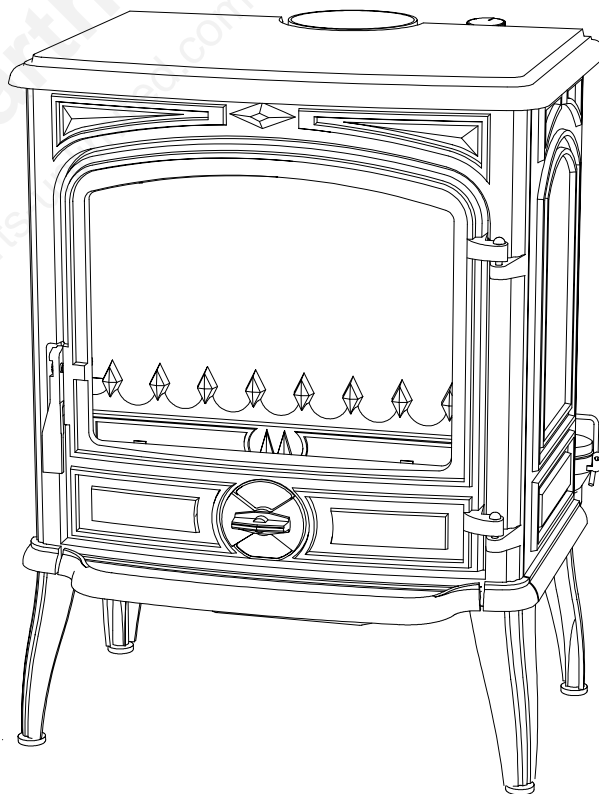

Installation and Service must be performed by a Qualified Installer, Service Agency or the Oil Supplier

**WOLF STEEL LTD., RR#1, 24 NAPOLEON RD.,
BARRIE, ON., CANADA L4M 4Y8 (705)721-1212**



Fax: (705)722-6031

Email : ASK@NAPOLEON.ON.CA

Web: WWW.NAPOLEONFIREPLACE.COM

Document n° 1043-1 ~ 15/01/2002



CONTENTS

PG. 2 . . INTRODUCTION

- PG. 3 . . Warranty
- PG. 4 . . General information
- PG. 4 . . Care of enamelled parts
- PG. 4 . . Care of glass

PG. 4 . . INSTALLATION

- PG. 4 . . Unit and specifications
- PG. 5 . . Location and clearances
- PG. 5 . . Safety precautions
- PG. 5 . . Draft air
- PG. 5 . . Combustion air for NON mobile home installation.

PG. 6 . . INSTALLATION

- PG. 6 . . Venting
- PG. 6 . . Outside air
- PG. 6 . . Chimney specifications
- PG. 6 . . Chimney connector
- PG. 7 . . Chimney installation
- PG. 7 . . Adding chimney sections

PG. 7 . . MOBILE HOME INSTALLATION

PG. 8 . . FINISHING

- PG. 8 . . Mounting flue collar and blanking plate
- PG. 8 . . Leveling the stove
- PG. 8 . . Door seal adjustment
- PG. 8 . . Ash tray installation
- PG. 8 . . Fitting the "visioflamme" (optional)

PG. 8 . . FUEL SUPPLY

PG. 10 . OPERATING INSTRUCTIONS

- PG. 10 . Understanding your oil stove
- PG. 10 . Lighting instructions
- PG. 11 . Shut down

PG. 11 . ADJUSTMENTS

- PG. 11 . Oil flow adjustments
- PG. 11 . Overheating

PG. 12 . MAINTENANCE

- PG. 12 . Seasonal maintenance
- PG. 12 . Door gasket replacement
- PG. 12 . Removing the flue baffle
- PG. 13 . Ordering replacement parts
- PG. 13 . Replacement parts

PG. 16 . TROUBLE SHOOTING

PLEASE RETAIN THIS MANUAL FOR FUTURE REFERENCE

INTRODUCTION

WARNING

- The stove is an oil-fired stove. Do not burn wood or other materials in this stove.
- Adults and especially children should be alerted to the hazards of high surface temperatures and should stay away to avoid burns or clothing ignition. Supervise young children when they are in the same room as the stove.
- Due to high temperatures, the stove should be located out of traffic and away from furniture and draperies.
- Clothing or other flammable material should not be placed on or near the stove.
- Do not allow anyone to operate this appliance unless they are thoroughly familiar with the operating instructions.
- The use of a firescreen is strongly recommended as a further safeguard.
- It is imperative that the controls, burner, its passageway in the stove and venting system are kept clean. The stove and its venting system should be inspected before use

and at least annually by a qualified service person. More frequent cleaning may be required due to excessive soot build-up. The stove area must be kept clear and free from combustible materials, gasoline and other flammable vapours and liquids.

- Under no circumstances should this stove be modified.
- Do not draw combustion air from a wall, floor or ceiling cavity or from an enclosed area such as an attic, a basement or a garage.
- Do not use this stove if any part has been under water immediately call a qualified service technician to inspect the stove and to replace any part of the control system which has been under water.
- Do not operate the stove with the glass door opened, cracked or broken. Replacement of the glass should be done by a licensed or qualified service person.
- Do not strike or slam shut the stove glass door.

NAPOLEON oil stoves are manufactured under the strict Standard of the World Recognized ISO9001 Quality Assurance Certificate.

NAPOLEON products are designed with superior components and materials, assembled by trained craftsmen who take great pride in their work. The complete stove is thoroughly inspected by a qualified technician before packaging to ensure that you, the customer, receives the quality product that you expect from NAPOLEON.

NAPOLEON OIL STOVE PRESIDENT'S LIFETIME LIMITED WARRANTY

The following materials and workmanship in your new NAPOLEON oil stove are warranted against defects for as long as you own the stove. This covers : combustion chamber, heat exchanger, borosilicate glass (thermal breakage only), gold plated parts against tarnishing, and porcelainized enamelled components.

Wearable parts such as carburetor and catalytic components, oil reservoir, burner, flue baffle and high temperature paint are covered and NAPOLEON will provide replacement parts free of charge during the first year of the limited warranty.

Labour related to warranty repair is covered free of charge during the first year. Repair work however, requires the prior approval of an authorized company official. Labour costs to the account of NAPOLEON are based on a predetermined rate schedule and any repair work must be done through an authorized NAPOLEON dealer.

CONDITIONS AND LIMITATIONS

NAPOLEON warrants its products against manufacturing defects to the original purchaser only —i.e., the individual or legal entity (registered customer) whose name appears on the warranty registration card filed with NAPOLEON, provided that the purchase was made through an authorized NAPOLEON dealer and is subject to the following conditions and limitations :

This factory warranty is non-transferable and may not be extended whatsoever by any of our representatives.

The oil stove must be installed by an authorized service technician or contractor. Installation must be done in accordance with the installation instructions included with the product and all local and national building and fire codes.

This limited warranty does not cover damages caused by misuse, lack of maintenance, shipping, accident, alterations, abuse or neglect. Parts installed from other manufacturers will nullify this warranty.

This limited warranty does not cover chipping flaking of porcelainized enamelled components where the stove has been installed in a salt air or highly humid environment that may be corrosive or cause rust. Stove inspection for damage to the enamel should be done prior to accepting it.

This limited warranty further does not cover any scratches, dents, corrosion or discolouring caused by excessive heat, abrasive and chemical cleaners nor chipping on porcelain enamel parts, nor any venting components used in the installation of the stove.

In the first year only, this warranty extends to the repair or replacement of warranted parts which are defective in material or workmanship provided that the product has been operated in accordance with the operation instructions and under normal conditions.

After the first year, with respect to the President's Limited Lifetime Warranty, NAPOLEON may, at its discretion, fully discharge all obligations with respect to this warranty by refunding to the original warranted purchaser the wholesale price of any warranted but defective part(s).

After the first year, NAPOLEON will not be responsible for installation, labour or any other costs or expenses related to the reinstallation of a warranted part, and such expenses are not covered by this warranty.

Notwithstanding any provisions contained in the President's Limited Lifetime Warranty, NAPOLEON'S responsibility under this warranty is defined as above and it shall not in any event extend to any incidental, consequential or indirect damages.

This warranty defines the obligations and liability of NAPOLEON with respect to the NAPOLEON oil stove and any other warranties expressed or implied with respect to this product, its components or accessories are excluded. NAPOLEON neither assumes, nor authorizes any third party to assume, on its behalf, any other liabilities with respect to the sale of this product. NAPOLEON will not be responsible for : over-firing, downdrafts, spillage caused by environmental conditions such as rooftops, buildings, nearby trees, hills, mountains, inadequate vents or ventilation, excessive venting configurations, insufficient makeup air, or negative air pressures which may or may not be caused by mechanical systems such as exhaust fans, furnaces, clothes dryers, etc.

Any damages to the stove, combustion chamber, enamelled finish or other component due to water, weather damage, long periods of dampness, condensation, damaging chemicals or cleaners will not be the responsibility of NAPOLEON.

The bill of sale or copy will be required together with a serial number and a model number when making any warranty claims from your authorized dealer. The warranty registration card must be returned within fourteen days to register the warranty.

NAPOLEON reserves the right to have its representative inspect any product or part thereof prior to honouring any warranty claim.

General information

Nominal heat output	Oil consumption **		Chimney draft required		Weight	Flue outlet inside diameter
	max speed	min speed	max speed	min speed		
27,300 BTU/hr	.25 US gal/hr	.073 US gal/hr	.06" w.c.	.024" w.c.	220 lbs	5 inches
8 kW	0.96 liter/h	0,28 liter/h	15 Pa	6 Pa	100 kg	125 mm

** 1 pint = 0.568 liter 1 quart = 1.136 liter 1 gallon (Brit.) = 4.546 liter 1 US gal = 3.785 liter
 1 liter = 1.760 pints 1 liter = 0.879 quart 1 liter = 0.22 gal (Brit.) 1 liter = 0.26 gal (US)

Pints, quarts and gallons are Canadian unless otherwise noted.

Care of enamelled parts

Do not use abrasive cleaners to clean these parts. Buff lightly with a clean, dry cloth. Porcelain enamel components must be handled with care. The baked-on finish is "glasslike". If struck, it will chip. Touch-up paint is available through your Napoleon dealer.

Care of glass

If the glass is not kept clean permanent discoloration and / or blemishes may result. Normally a hot burn will clean the glass. The most common reason for dirty glass is running the unit at a low burning rate. If it is necessary to clean the glass, use a soft cloth with a nonabrasive cleaner. Coarse cleaning materials may cause scratches or otherwise damage the glass. Scratches can develop into cracks or breaking of the glass.

DO NOT CLEAN GLASS WHEN HOT !

The glass is very strong for maximum performance. However, always close the door gently. If the glass should ever crack while the fire is burning, do not open the door until the fire is out and do not operate the stove again until the glass has been replaced with new borosilicate glass, available from your Napoleon / Wolf Steel Ltd. dealer. **DO NOT SUBSTITUTE MATERIALS.** Check gaskets and seals regularly.

INSTALLATION

WARNING : Improper installation, adjustment, alteration, service or maintenance can cause injury or property damage. Refer to this manual. For assistance or additional information consult a qualified installer, service agency or the oil supplier. □

Unit and specifications

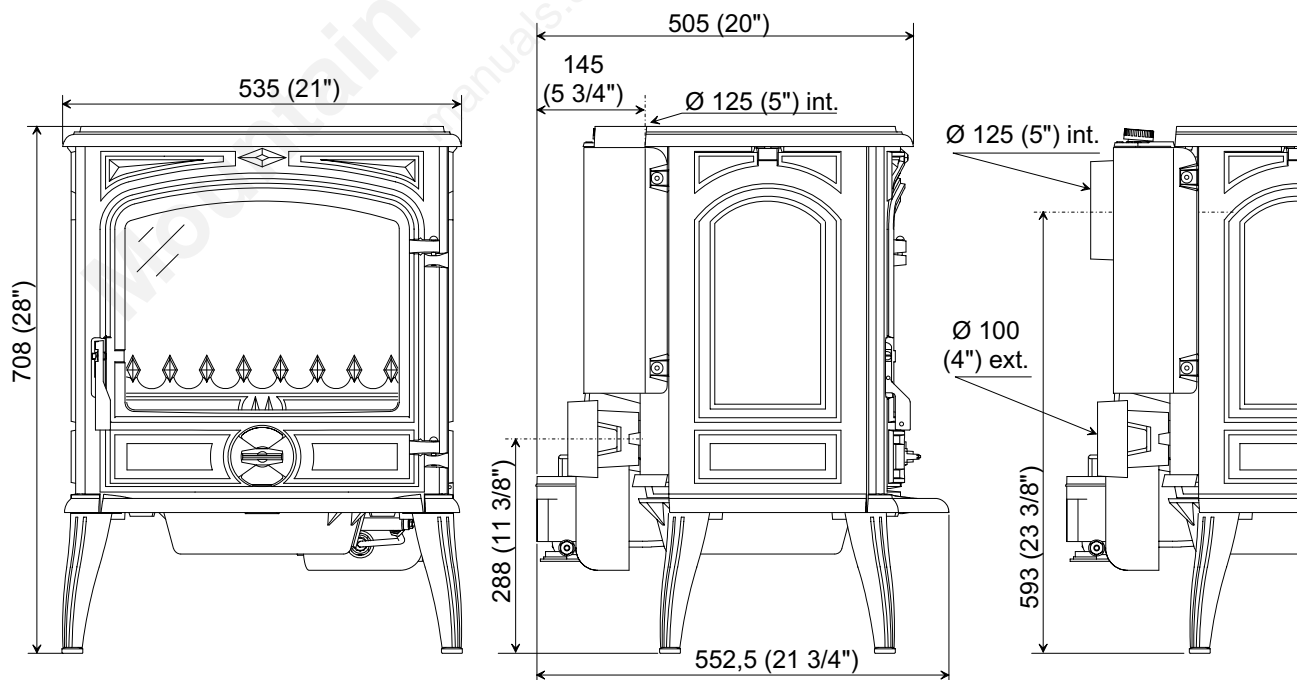

Figure 1

Location and clearances

If the stove is to be installed on a combustible floor, it must be installed on sheet metal or a tile. The oil drip tray, 72636 (not supplied) is a suitable substitute for either of these two pads.

Maintain these minimum clearances to combustibles (fig. 2) :

A 10 inches (250 mm)

B 13 inches (330 mm)

C 7 inches (180 mm)

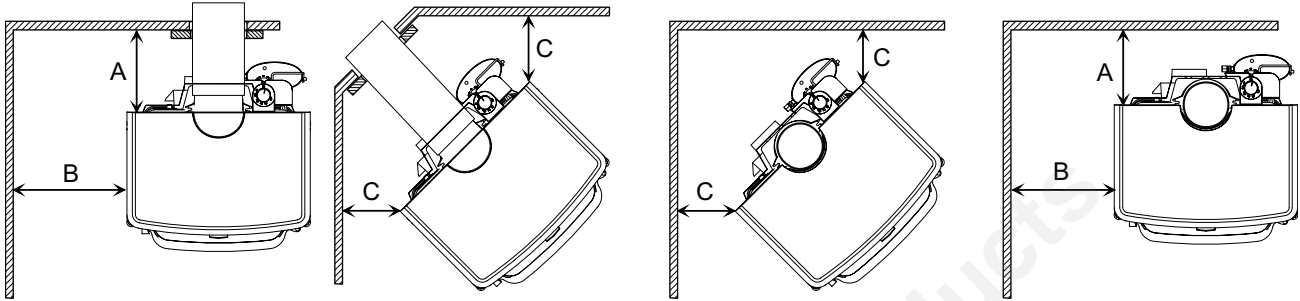

Figure 2

Use a double wall pipe for rear connection.

If reduced clearances are needed, obtain requirements from your local building code authorities (Installation code book).

Safety precautions

Please read the installation instructions carefully, prior to installing the oil stove.

Your Napoleon oil stove must be installed in accordance with all national and local building code standards.

Consult the authority having jurisdiction (such as municipal building department, fire department, fire prevention bureau, etc.) to determine the need to obtain a permit. If you are in doubt about the proper installation for your situation, contact your dealer or local building or fire official.

Draft air

Most of the heat generated by the oil stove is used to warm the room air. However, part of the generated heat escape as exhaust gas through the chimney, creating a 'chimney draft'. To ensure proper operations of the stove, it must be connected to a chimney having a sufficient draft capacity to operate the stove satisfactorily.

Flue draft, measured as negative pressure in the chimney, is created by the hot, rising combustion gas. The draft, in turn, permits combustion air to enter the burner and emit the exhaust gases from the chimney to complete the combustion cycle. For the 8 kW, a draft of 0.06" (or 15 Pa) water column for maximum input burn and 0.024" (or 6 Pa) for minimum input burn is rated best to obtain the utmost performance of the oil stove.

Basic criteria essential to create and maintain chimney draft are :

1. Availability of combustion air.
2. Diameter and height of chimney.
3. Heat generated by the fire.

These segments work together to create the chimney draft. To alter one of them will affect the other two and change the amount of draft in the chimney and ultimately the stove's performance. To ensure that adequate chimney draft is maintained, the chimney should be kept clean and without cracks. As soon as the oil stove has been installed, the chimney draft should be checked with a draftmeter. Remove the screw located on the flue collar to introduce the draftmeter, replace the screw once all the necessary tests will have been carried out. Flue draft is measured when the oil stove is hot (after a minimum use of 30 minutes) to establish a true reading of the draft.

For the recommended operating draft level, see 'General Information' on page 4. Draft adjustment can be made through use of the draft regulator located at the back of the oil stove (2, figure 14, page 9). In the event that the chimney draft is excessive or irregular, a draft stabiliser should be fitted to chimney connector.

Combustion air for NON mobile home installation.

The oil burning stove consumes about 4000 ft³ of air per US gallon of oil (30 m³ of air per litre of oil). This air is introduced into the burner through air inlets and exits the chimney as combustion gas. For the oil stove to function properly, an adequate supply of combustion air is required. There are many other appliances in your home competing for air such as : a kitchen range hood, forced air heating devices, clothes dryer or a bathroom exhaust fan. Clothes dryers exhaust 400 CFM (cubic feet / minute) ; range hoods and exhaust fans can exhaust up to 150 CFM. If there is insufficient combustion air, you may need to open a door or window to avoid adversely affecting the performance of the oil stove.

The manufacturer of the stove and/or his agent is not responsible for any smoking or related problems or damages resulting from the lack of adequate combustion air. It is the responsibility of the installation contractor to ensure that adequate combustion air is available to the stove at all times or to use an external connection (fig. 3, page 6) to avoid reducing the overall efficiency of the stove.

INSTALLATION

DO NOT INSTALL IN A ROOM USED FOR SLEEPING.

The stove must be firmly bolted to the floor with 1/4 inch lag bolts (fig. 8, p. 8). Minimum clearances to combustibles are as shown in figure 2, page 5.

VENTING

The chimney must be installed in accordance with the manufacturer's instructions. Use only specified components with no substitutions. The chimney and pipe must extend at least 8 feet above the stove and 3 feet above the highest point of the roof. Install a rain cap at the top which will not impede the smoke exhaust. The chimney must be supported at the ceiling or roof so that its weight does not rest on the stove.

It must be installed between ceiling joists, with radiation shield and roof flashing, so that the structural strength, insulation and waterproof qualities of the home are not lessened. Seal with silicone to maintain a vapour barrier at the chimney and outside air pipe penetrations. To check that the air pipe is well fixed.

OUTSIDE AIR

Connection from the stove's air intake to the outside is mandatory in mobile homes only, either through a hole in the wall, or through a hole in the floor. Use a fresh air kit. Secure the 4 inch diameter aluminium liner to the air intake collar. Avoid cutting away floor joists, wall studs, electrical wires of plumbing. Seal around the outside pipe with insulation to prevent drafts.

IF ROOM AIR STARVATION OCCURS BECAUSE THE FRESH AIR INTAKE IS BLOCKED WITH ICE, LEAVES, ETC., OR BECAUSE THE STOVE DOOR WAS LEFT OPEN, OR DUE TO A STRONG EXHAUST FAN OPERATING ETC., DANGEROUS FUMES AND SMOKE FROM THE OPERATING STOVE COULD BE DRAWN INTO THE ROOM.

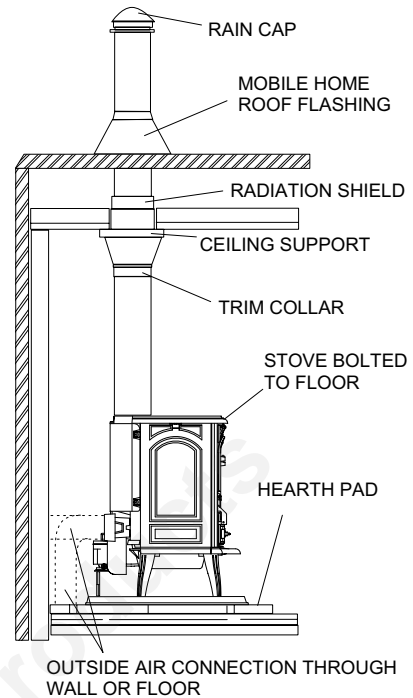

Figure 3

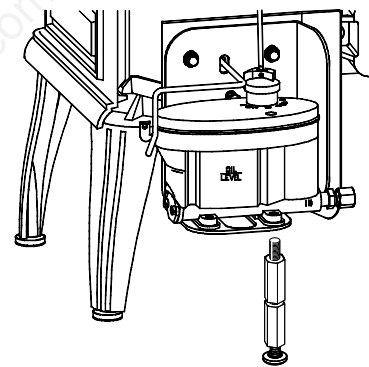

Figure 4

THE TOTAL SMOKE PIPE LENGTH SHOULD NOT EXCEED 40% OF THE CHIMNEY HEIGHT ABOVE THE STOVE TO A MAXIMUM HORIZONTAL RUN OF 10 FEET.

All smoke pipe must slope upwards at a minimum of 1/4" per foot (6 mm/300 mm) and all connections must be tight and secured by three sheet metal screws equally spaced.

An uninsulated smoke pipe shall not pass through an attic, roof space, closet or similar concealed space, or through a floor, ceiling, wall or partition, or any combustible construction.

Chimney specifications

If the chimney is 'cold', the normal combustion cycle will not work. A cold chimney may be caused by disuse, being too large, not insulated, being external or not high enough so not enough draft. Exterior chimneys cool rapidly, causing poor draft and condensation.

Chimney connector

The stove should be located as close as possible to the chimney to avoid draft problems. Horizontal flue connectors restrict the establishment of the required chimney draft and thereby prevent the normal functioning of the stove. Ensure that the connection is supported and fastened to the stove.

Example : Screw the connector to the flue collar or wrap plumber's strapping around the vertical section of the connector and screw to either edge of the rear heat shield. Ensure that the strapping is snug fitting. A single wall chimney connector may be used only within the room where the unit is located, between the oil stove and the chimney but never passing through a combustible ceiling or wall. Minimum connector clearances to combustibles are to be maintained. If necessary, where local codes allow, a wall thimble may be used.

There are two types of chimney connectors :

A single wall chimney connector may be used for top connection :

This connector must be 316 grade 26 gauge stainless steel or 1 mm vitreous enamelled steel and with a 5" (127 mm) diameter. Secure the connector joints with 3 sheet metal screws. The joints are to be airtight. All connector sections must be attached to the unit and to each other with the crimped or male end pointing down towards the oil stove.

Use a double wall chimney connector for rear connection :

The connector should be of the same make (manufacturer) as the chimney components.

Chimney installation

Connection to a A-VENT chimney :

An A-Vent chimney, either 4" (101,6 mm.) or 5" (127 mm.) in diameter may be used. The minimum chimney height is to be 15 feet or 4.6 metres measured from the appliance flue collar to the top of the chimney but not including any chimney caps. Installation of all chimney systems is to be in accordance with the chimney manufacturers installation instructions. If the stove is to be connected to a masonry chimney, a stainless steel liner is required. **DO NOT USE ANY MAKESHIFT MATERIALS DURING INSTALLATION.**

1. Move the stove into position with the flue centred, mid point between two joists to prevent having to cut them. Use a plumb bob to line up the centre.
2. Cut and frame an opening in the roof to provide a 2" (50 mm) clearance between the outside of the chimney and any combustible material. **DO NOT FILL THIS SPACE WITH ANY TYPE OF MATERIAL.** Nail headers between the joists for extra support. Firestop spacers must be placed on the bottom of each framed opening in any floor or ceiling that the chimney passes through (figure 5).
3. Hold a plumb bob from the underside of the roof to determine where the opening in the roof should be. Cut and frame the roof opening to maintain proper 2" (50 mm) clearances (figure 6).

Example : A = Chimney diameter + 2 times the required clearance from chimney to combustible framing materials.

Connection to a L-VENT chimney :

This appliance is certified to be connected to a L-VENT chimney, 5" (127 mm). Use NAPOLEON ADAPTOR, W 175-0198. This adaptor is specifically designed for Energy Vent Chimney.

Adding chimney sections

Add chimney sections, twist locking (clockwise) securely, to the required height. Safety requirements dictate that the chimney must be at least 3 feet (915 mm) higher than the highest point where it passes through the roof and at least 2 feet (610 mm) higher than the highest part of the roof or structure that is within 10 feet (3.05 m) of the chimney, measured horizontally (figure 7). Obstacles close to the chimney may cause down drafts which may be prevented by the installation of a chimney cap fitted with a wind deflector. If your chimney system is enclosed within the attic area, a rafter radiation shield is required.

MOBILE HOME INSTALLATION

In mobile home installation, the oil stove must be installed with an oil drip tray. Order this part, 72636, from your Napoleon dealer

When installing the OS11 into a mobile Home, a carburetor support (supplied) must be installed for extra support of the carburetor (fig. 4). Ensure the support is adjusted to make contact with the floor. Outside air intake is mandatory in mobile homes only.

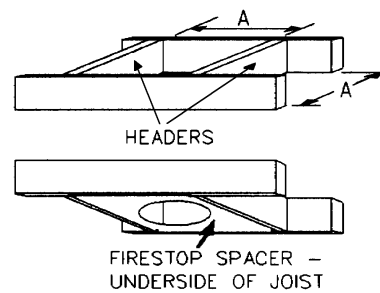

Figure 5

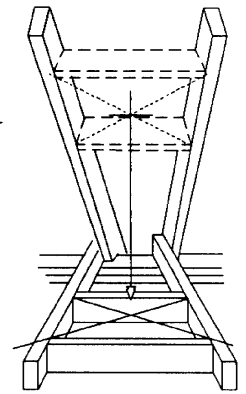

Figure 6

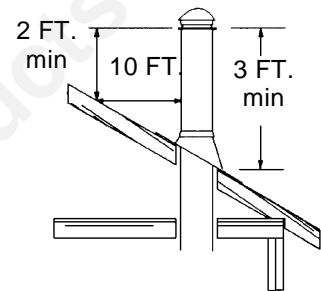

Figure 7

FINISHING

Mounting flue collar and blanking plate

The stove is supplied with a connection flue at top. The flue collar is reversible (2 screws) so that the smoke exit can be done at rear or on the top (figure 12 and figure 13, page 9).

Leveling the stove

Four adjusting bolts with caps are supplied and which have been placed in the burner for packing purposes only. Fit the screws and caps to the bottom of the stove legs (3, figure 8). Place the level on the burner ring and adjust the bolts until the burner has reached a level position (figure 9). Secure the stove to the floor (2, figure 8) with the bracket provided (1, figure 8).

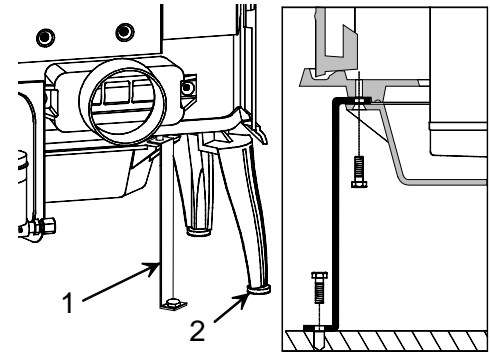

Figure 8

Door seal adjustment

Figure 10

The closing latch rotates around a positioned cam.

- Remove the ceramic rope gently.
- Loosen screw 1.
- Turn cam 2 to desired position.
- Tighten screw 1.

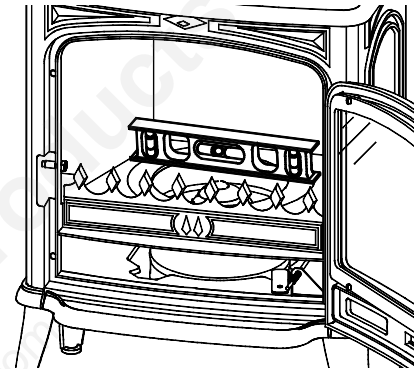

Figure 9

Ash tray installation

Figure 11

To avoid damage to the ash tray during transport, it has been disconnected and stored behind the main door of the oil stove. To reinstall the ash tray to the front of the oil stove, tilt the tray at a 45° angle, center onto tab 'A' and lower into place.

Fitting the "visioflamme" (optional)

Slide each glass piece so that it fits into the upper and lower channels of the reflector. Use pliers to pinch the ends of the channels to prevent glass from falling out.

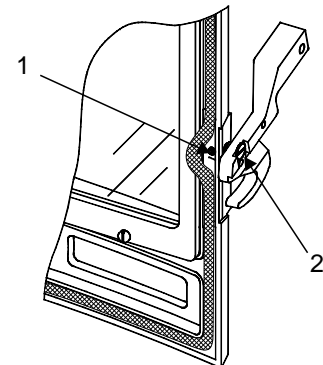

Figure 10

FUEL SUPPLY

The NAPOLEON cast iron oil burning stove is designed and fitted with a special carburetor to use only a specific category of fuel oil. This fuel oil must be clean and free of any dirt or traces of water. Impurities in the fuel oil can cause a reduced efficiency level.

The only fuel to be used with this heating appliance is FURNACE OIL N O . 1 OR NO. 2 .
DO NOT allow the oil tank to get empty. To do so may cause the stove to soot and increase the risk of a chimney fire.
Never use gasoline, motor oil or any gasoline contaminated oil.
The oil tank should be located in such a manner to prevent exposure to direct sunlight or be close to any source of intense heat.

The fuel system of an oil burning stove can either be a gravity system or one equipped with a fuel suction pump. The system selection depends on the location of the fuel tank.

The fuel system of this stove is designed to supply fuel by gravity pressure only. If the supply tank location is lower than the stove, it will be necessary to use the Napoleon SP32 suction pump. The SP32 should be installed a minimum of 12" above the stove carburetor and a minimum of 6" horizontally from the stove. This height difference will provide the necessary head pressure to feed the fuel to the carburetor.

A height difference between oil tank and oil stove in excess of 8 feet (2.44 meters) should be avoided but if necessary an oil pressure regulator must be fitted close to the carburetor to mitigate the pressure in the feeder line. The oil feeder line or oil supply line must be copper tubing with a minimum outside diameter of 5/16" (8 mm).

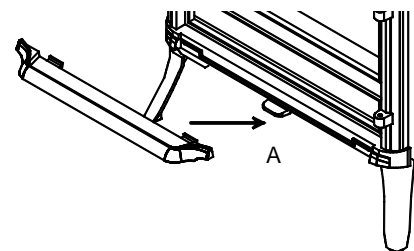

Figure 11

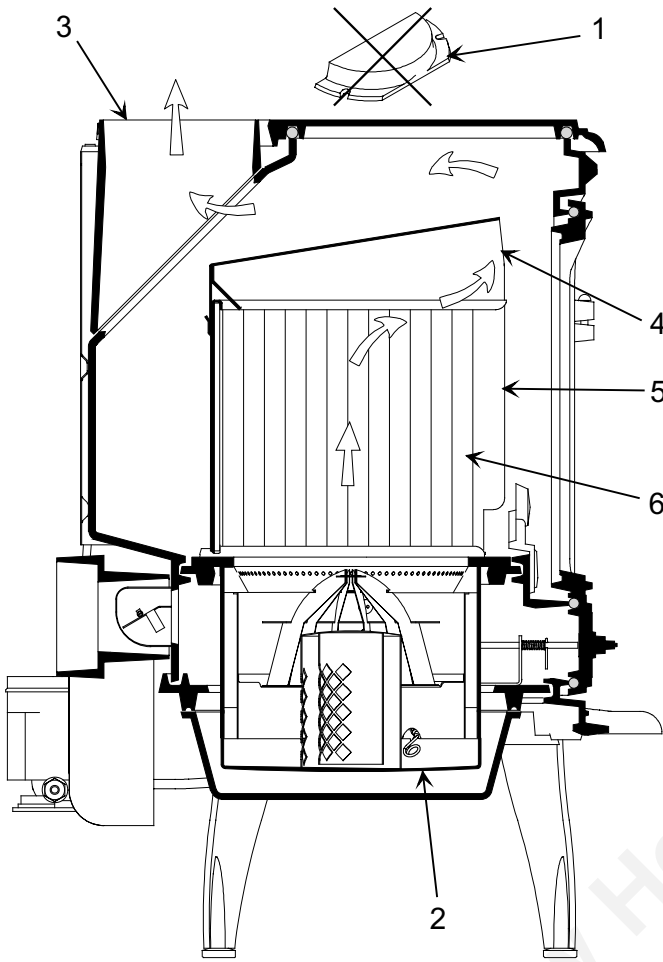

Figure 12

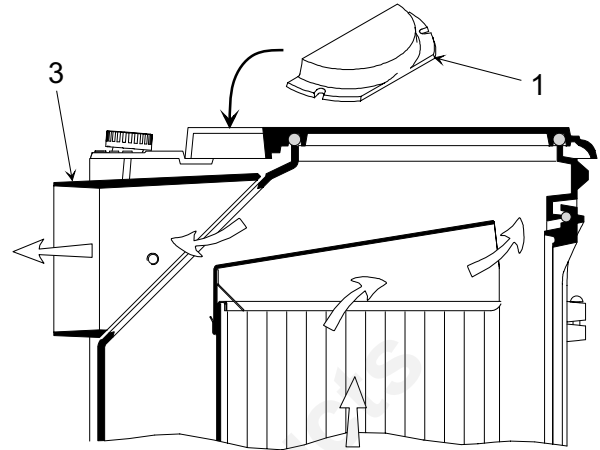

Figure 13

Figure 12 - Top flue outlet
Figure 13 - Rear flue outlet

- 1. Blanking plate
- 2. Burner
- 3. Flue collar
- 4. Baffle
- 5. Reflector
- 6. Optional mirrors

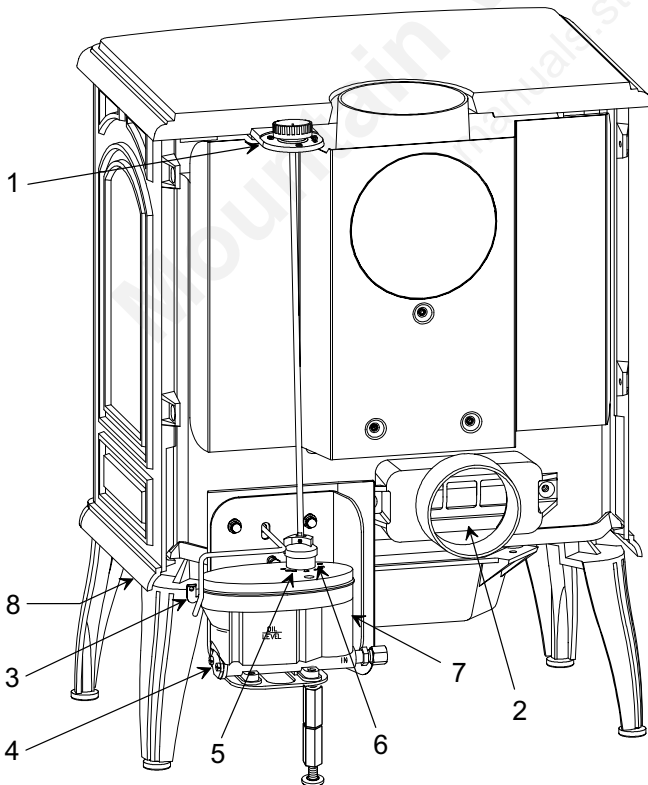

Figure 14

Figure 14 - Operating devices

- 1. Control knob
- 2. Intake collar
- 3. Safety lever
- 4. Control filter access
- 5. Min. setting adjustment screw
- 6. Max. setting adjustment screw
- 7. Carburetur
- 8. De-scaling lever

OPERATING INSTRUCTIONS

Understanding your oil stove

Furnace oil is fed from the tank to the burner floor (A) where it is ignited by means of a firestarter. The heat produced by this flame brings the burner temperature to the required level to vaporize the fuel. Oil will only burn as a vapour not a liquid. Room combustion air enters the burner through the air inlet holes (B).

The stove carburetor contains a filter to trap impurities. This filter must be cleaned periodically with the frequency depending on the fuel purity. A safety lever controls fuel flow. Oil can only enter the float chamber when the safety lever is depressed. Oil temperature variations will affect the oil flow into the float chamber. A float in the chamber raises the fuel level available to the burner. The carburetor is also controlled by a control knob which turns from "0" (off) to "6" (high setting) (fig. 16).

In the center of the burner is the catalyser (C) which aids the good combustion. When the stove is in operation, the catalyser glows red. The stove should not be used without both the catalyser, catalyser top (D) and ring (E).

To the right of the unit, just below the side panel is a small push rod called a de-scaling lever, (F), that should be pushed and pulled in and out as well as turning slightly at the same time to keep the inlet pipe clear of carbon buildup. This should be done on a weekly basis.

Because the draft from the chimney is never uniform, a draft regulator has been added to ensure a constant air intake to the burner regardless of external factors.

When the door is opened, an automatic oil valve shut-off rod lifts the safety lever (B, figure 17) and the stove shuts down (A, figure 17)

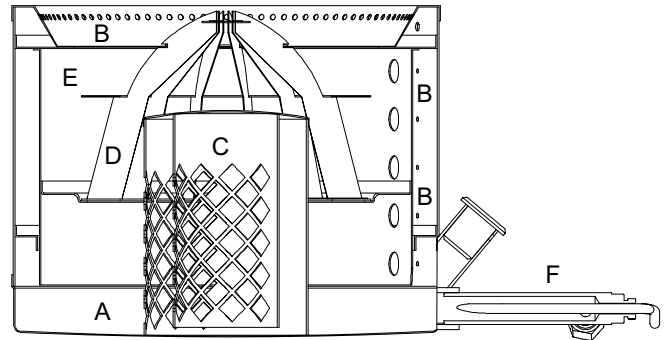

Figure 15

Never light the burner if any oil is in the burner pot. The burner pot must be cleaned thoroughly prior to lighting or relighting.

Keep the door of the oil stove closed when it is in operation except during lighting procedures.

Proceed once installation is complete and all necessary instructions have been followed

When lit for the first time, the stove will emit a slight odour for a few hours. This is a normal temporary condition caused by the curing and the "burn-in" of internal paints and lubricants used in the manufacturing process and will not occur again. After extended periods of non-operation such as following a vacation or a warm weather season, the stove may emit a slight odour for a few hours. This is caused by dust particles burning off. In both cases, open a window to sufficiently ventilate the room.

Lighting instructions

1. Through the open door, remove the catalyser components (C, D and E, figure 15) from the burner.
2. Ensure that the burner pot is dry, and clean with no oil remaining.
3. Place a piece of thumb nail size firestarter gel (methane pellet or paraffin paper or 2 tablespoons of methylated spirits) into the burner pot.

NEVER USE ALCOHOL OR GASOLINE AS A FIRESTARTER.

Light with a long taper or wadded piece of paper. Immediately replace the catalyser components (figure 15). Ensure that the top is centred.

4. Closed the door and set the control knob to "0" (figure 16). Depress safety lever to allow oil flow into the carburetor (B, figure 17).
5. Turn the carburetor control knob to the "1" dial setting.
6. Allow 10 to 15 minutes of low burn for the flames and chimney draft to stabilize. The catalyser should glow red before changing to a higher setting.
7. The stove may now be adjusted to the desired heat setting, usually between "2" and "4". Never switch straight from "1" to "6". A longer burner life will be achieved if the control knob is moved one setting at a time leaving approx. 5 minutes between settings.

If the fire goes out, return the carburetor control knob to the "0" setting. Let the burner cool off completely before repeating the lighting procedure. *Clean out any oil before relighting.*

NEVER OPERATE THE STOVE WITH THE DOOR OPEN OR AJAR.

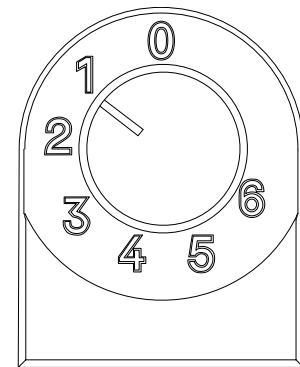

Figure 16

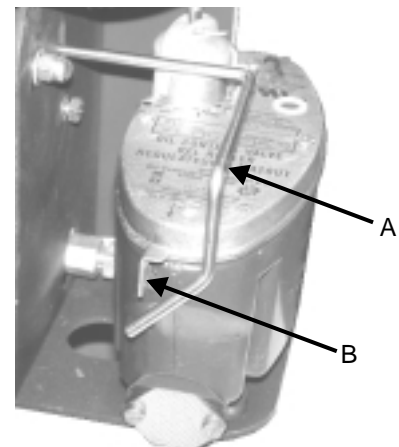

Figure 17

Shut down

1. Turn the control knob to "0" setting.
2. Lift the safety lever.
3. Turn off the oil tank fuel supply valve.

The oil tank fuel supply valve should always be shut off when the oil stove is not in operation.

ADJUSTMENTS

Oil flow adjustments

The oil flow setting is done by the manufacturer and normally should not require any adjustments. These adjustments if required must be done by a qualified technician.

Always burn the stove on low for at least 15 minutes before attempting to adjust the flow.

Turn the screw only a quarter turn at a time. Wait 10 to 15 minutes between adjustments to allow the fire to stabilize.

If the burner fails to respond to the control knob settings, other possible causes should be checked (chimney draft, dirty filter or the oil supply line) prior to attempting to adjust the carburetor.

Adjustment at minimum speed :

Turn the control knob 'A' to the (1) dial setting and allow the burner to run for a few minutes. The flame must completely cover the bottom of the burner pot and the catalyser should glow red. If the flame is too small, the oil stove will quickly soot up. Turn the set screw 'B' (figure 18), located on the top of the carburetor, clockwise with a screwdriver to increase the flow of oil.

If the flame is too high, reduce the oil flow by turning the set screw counter-clockwise. The flames should be blue with occasional yellow tips. The catalyser should glow red.

Adjustment at maximum speed :

Gradually turn the control knob 'A' to dial setting (6) and allow the burner to run for a few minutes. The flame should be in a cone form with the top level with the upper part of the door. If the flame is too low, the oil flow rate should be increased by turning the set screw 'C' (figure 18), on the carburetor counter-clockwise. If the flame is too high, turn the screw clockwise.

The flames should have only occasional contact with the burner ring. The bottom 2" (50 mm) of the flames should be blue in colour with the remaining portion yellow.

Overheating

Adjusting the control knob to a high setting prematurely allows too much oil to enter the burning pot. This and/ or the lack of sufficient draft creates a fire intensity which in turn creates vibrations. Similarly, if the oil stove or the chimney connector start to glow red, the appliance is being overheated. Turn off the oil supply until the fire has decreased to a normal steady burn. Adjust draft to specifications.

Adjustments, if any, to your oil stove have been made by your installer. Do not attempt any further adjustments yourselves but report any failures or shortcomings in the stove's performance to your authorized dealer.

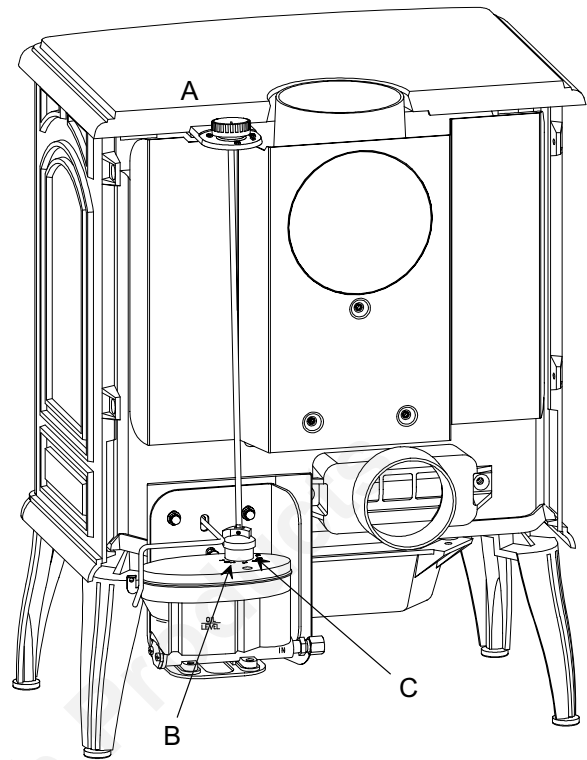

Figure 18

MAINTENANCE

Seasonal maintenance

WEEKLY - DESCALE

Push and pull the de-scaling lever in and out as well as turning slightly at the same time completely two or three times. Push in for normal burner operations or before relighting.

EVERY 3 TO 4 MONTHS - CLEAN BURNER

Remove all three catalyser components (C, D, E, figure 15, page 10). Remove any carbon residue and remaining oil from the burner using a slightly damp cloth. Buff dry before reinstalling.

EVERY 3 TO 4 MONTHS : CHIMNEY INSPECTION

The chimney and the chimney connector must be inspected at least once every 3 months during the heating season to ascertain whether there has been a buildup of soot in the system. If a soot buildup has occurred, it should be removed to reduce the risk of chimney fires.

ONCE OR TWICE A YEAR : FLUE BAFFLES INSPECTION

- Remove the flue baffle (page 12). If a soot buildup has occurred on the flue baffles and the combustion chamber, it should be removed.

YEARLY : CHIMNEY MAINTENANCE

The chimney is to be swept at least once a year. It is also recommended that prior to every heating season the entire system be professionally inspected, cleaned and repaired where necessary.

YEARLY - CLEAN CARBURETOR FILTER

1. Set the control knob to "0".
2. Turn off oil supply at the valve or the tank valve.
3. Raise the safety lever (D).
4. Place a container under the carburetor to contain any spillage. Remove the filter plug held on with two screws.
5. Pull out the filter (E) and clean in oil **using a soft brush. Never use a wire brush.**
6. Replace filter and plug.

Clean all enamelled stove panels and the outside of the glass using a slightly dampened cloth. **NEVER CLEAN WHEN THE STOVE IS HOT.**

DOOR GASKET REPLACEMENT

Check the door gasket periodically to ensure the seal is functioning properly and the door fits tight. Replace the gasket if necessary.

Removing the flue baffle

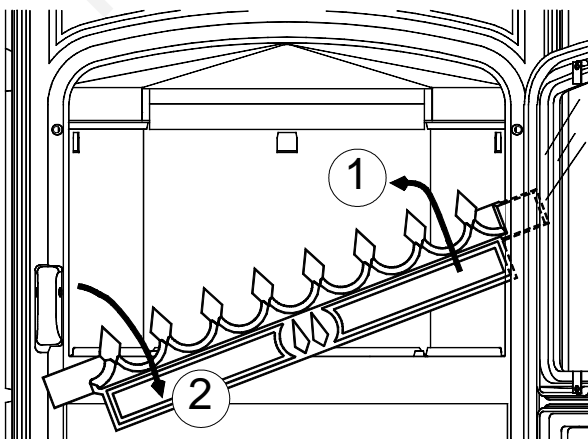

Figure 20

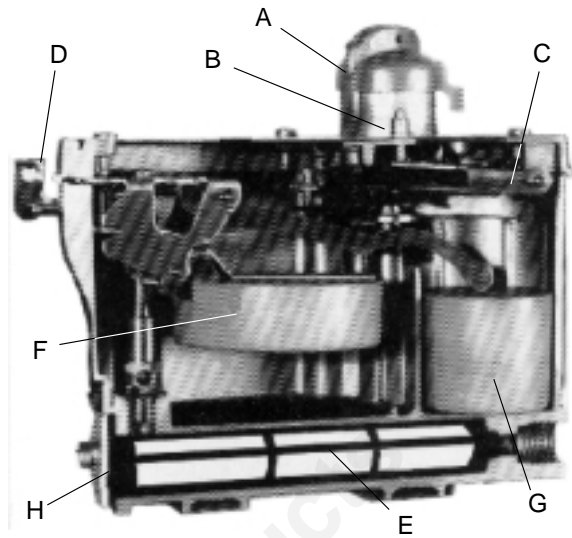

Figure 19

- A : Control knob
- B : Thermostat control
- C : Oil level regulator
- D : Safety lever
- E : Filter
- F : Main float
- G : Safety float
- H : Filter cavity

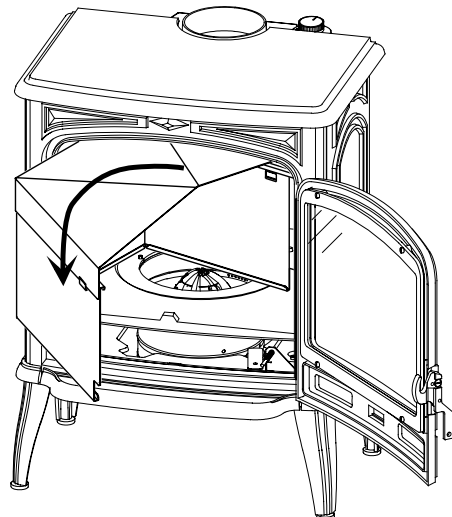

Figure 21

REPLACEMENTS**Ordering replacement parts**

Contact your dealer or the factory for questions concerning prices and policies on replacement parts. Normally all parts can be ordered through your Napoleon dealer or distributor. When ordering replacement parts always give the following information:

- | | | |
|---------------------------------------|------------------------|-----------|
| 1. Model & Serial number of fireplace | 3. Part code | 5. Finish |
| 2. Installation date of fireplace | 4. Description of part | |

Replacement parts

For warranty replacement parts, a photocopy of the original invoice will be required to honour the claim. Ordering Replacement Parts

When ordering spare parts, please indicate model number, colour code, parts description, and code number.

N°	Code	Description	Type	Qty	N°	Code	Description	Type	Qty
1	100917	Cam pin	12x20 M7	01	34	251204	Glass retainer		01
2	104708	Plug		01	35	261817	Heat shield		01
3	109552	Cap		04	36	276230	Reflector		01
4	109718	Chain		01	37	277902	Trap		01
5	110404	Hinge pin	6x30	02	38	300489	Base		01
6	119217	Descaler		01	39	301526	EF Door lock		01
7	119801	Bushing		02	40	260589	60 Heat shield		01
8	134107	Glove		01	41	303625	EF Top plate		01
9	134258	Bushing		01	42	303872	EF Flue collar		01
10	134601	Pin	2x20	02	43	306283	Back wall		01
11	142316	Gasket	7x3	1,01 m	44	307438	Fuel retainer		01
12	142874	Gasket		01	45	310732	EF R. side panel		01
13	142875	Gasket		01	46	310829	EF L. side panel		01
14	146304	Draught regulator		01	47	312633	Burner support		01
15	149868	Knob		01	48	315609	Air duct		01
16	164205	Tightness nut		02	49	320106	Base		01
17	165141	Float regulator		01	50	327903	EF Tray		01
18	166023	Spring		01	51	331111	EF Main door		01
19	179622	Regulator shaft		01	52	331500	Bracket		01
20	259036	Fixing plate		01	53	352159	EF Top plate		01
21	181617	Ceramic rope	Ø 4	0,53 m	54	359800	EF Front plate		01
22	105006	Ceramic rope	Ø 15	1,60 m	55	300125	EF Leg		04
23	188820	Ceramic glass		01	56	179623	Regulator shaft		01
24	189118	Brass screw	d. 10	01	57	622507	Flue baffle		01
25	189825	Screw	M5x6	01	58	905329	Burner		01
26	194401	Catalyser cover		01	59	905330	Complete burner		01
27	194402	Catalyser body		01	60	181630	Gasket	Ø 12	4,06 m
28	198205	Catalyser ring		01	61	181625	Ceramic rope	Ø 7	3,98 m
29	199204	Regulator filter		01	62	982645	Feed line regulator-burner		01
30	222205	Shaft-guide		01	64	445905	Fixing plate		01
31	236130	Sealing plate		01	65	988867	Complete door		01
32	236511	60 Burner support		01	80	124412	Strut		02
33	239723	60 Regulator support		01	81	160706	Leg		01

Optional :

W175-0198	NAPOLEON ADAPTOR 5" 'L' Vent
SP32	NAPOLEON SUCTION PUMP
72611	IGNITOR
72636	OIL DRIP TRAY
72632	VISIOFLAMME

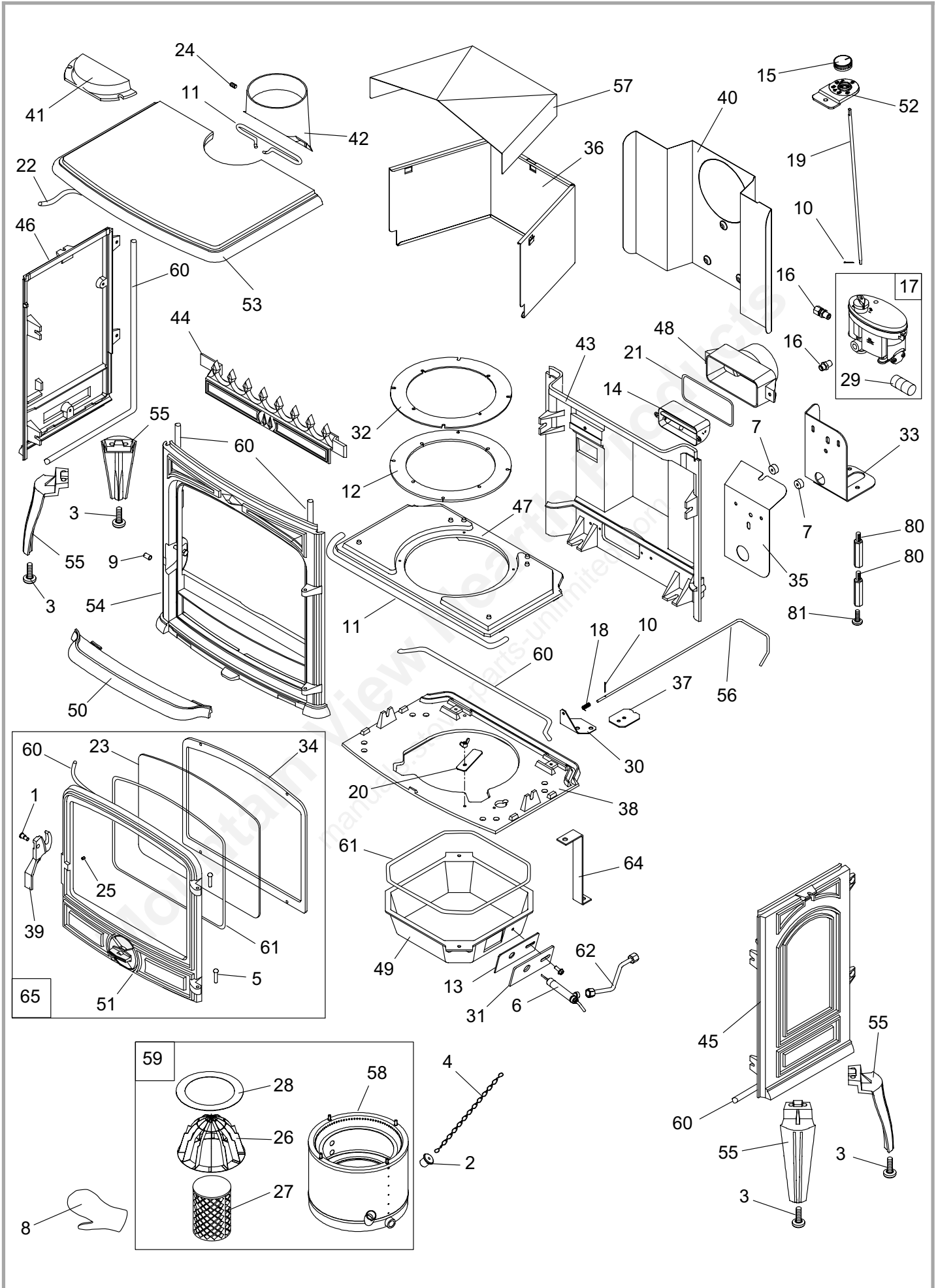

Figure 22

TROUBLE SHOOTING

SYMPTOM	PROBLEM	TEST SOLUTION
Flames extinguish during lighting.	Very cold chimney. No draft established	- Leave door ajar until fire has caught. - check air supply in the room
Fire extinguishes once firestarter has burnt off.	Fuel tank is empty	- Fill tank
	Fuel valve is closed.	- Open valve
	Main carburetor float not engaging.	- De-press the safety lever
	Control knob is set on "0"	- Adjust control knob to "1"
Fire extinguishes during use.	Fuel tank is empty.	- Fill tank
	Insufficient draft	- Call your installer
Flame is excessively large, smokey and sooty.	Fuel adjustment made too quickly.	- Return control knob to "1" ; wait for normal combustion. (catalyser should glow red). - Wait 5 to 15 minutes between each adjustment.
Stove burns noisily, extinguishes and relights itself.	Burner contains excess fuel	- Adjust to lower setting. If problem persists call your installer.
	Insufficient fuel	- Check that the de-scaler, the carburetor filter and burner pot are cleaned.
Fire smokes.Soot build up noticed. Flame imbalance	Insufficient air supply.	- Increase fresh air supply (open door, window ; add make up air supply)
	Downdraft or blockage in chimney	- Check Chimney for Soot build up. clean if necessary.
		- Ensure chimney height is sufficient and cap is not affected by any nearby obstructions.
		- Room is in negative pressure. Increase fresh air supply. Check draft with draft meter and adjust if not to requirements. See page 5.
	Oil flow is too low on 1 setting.	- Adjust low flow rate while control is set on "1", call your installer.
	Stove is not level. Flame imbalance.	Check level. Adjust if necessary.
	Catalyser not centered. Uneven fuel distribution resulting in secondary air shortage.	Center catalyser assembly
	Insufficient fuel	- Check that the de-scaler, the carburetor filter and burner pot are cleaned.
Coke build up noticed.	Excessive air supply.	- Adjust draft.