



INSTALLATION, OPERATING and SERVICE MANUAL

THE INSTALLATION OF THE UNIT SHALL BE IN ACCORDANCE WITH THE REGULATIONS OF THE AUTHORITIES HAVING JURISDICTION.

EH Electric Furnace

HEAD OFFICE
MARKETING / PRODUCTION
Newmac Mfg. Inc.

DEBERT AIR INDUSTRIAL PARK,
LANCASTER CRESCENT
P.O. BOX 9, DEBERT
NOVA SCOTIA, BOM 1G0
PHONE: 902-662-3840
FAX: 902-662-2581

WAREHOUSE
Newmac Mfg. Inc.

430 SPRINGBANK AVE., SOUTH
P.O. BOX 545
WOODSTOCK, ONTARIO
N4S 7Y5
PHONE: 519-539-6147
FAX: 519-539-0048



EMAIL: newmac@ca.inter.net
Website: newmacfurnaces.com



NOTICE TO HOMEOWNER: READ AND SAVE THESE INSTRUCTIONS

156156

2210047 MAY 2003

MODEL EH CENTRAL ELECTRIC WARM AIR FURNACE

GENERAL INSTRUCTIONS

It is the responsibility of the consignee of the unit to examine the package for damages and, if found, to note the same on the Carrier's Bill of Lading.

The furnace is shipped in one package. This includes the furnace assembly complete with elements, controls, blower, motor and casing, filter rack, filters, thermostat and instruction booklet.

The furnace has 240 volt elements and for

- 240volt, 2 wire, 240 volt blower motor, or
 - 240/120volt, 3 wire, 120 volt blower motor.
- All furnaces are 1 phase, 60 Hz.

See furnace label and this manual for more details.

Model	kW @ 240	BTU/hr Output	Static Pressure ins wc	Temp Rise °F	Blower Motor A		Minimum Circuit Ampacity, A		Maximum Circuit Fuse, A		Air Filter
					240V	120/240V	240V	120/240V	240V	120/240V	
EH10*	10	34,120	0.20/0.50	35/35	4	8	58	63	60	70	1 @20x20x1
EH15*	15	51,180	0.20/0.50	45/45	4	8	84	89	90	90	1 @20x20x1
EH20*	20	68,240	0.20/0.50	50/55	4	8	110	115	125	125	1 @20x20x1
EH25*	25	85,300	0.20/0.50	60/65	4	8	136	141	150	150	1 @20x20x1
EH30*	30	102,360	0.20/0.50	65/70	4	8	162	167	175	175	1 @20x20x1

Model	kW @ 240v	BTU/hr Output	Static Pressure ins wc	Temp Rise °F	Blower Motor A		Minimum Circuit Ampacity, A		Maximum Circuit Fuse, A		Air Filter
					240v	120/240v	240v	120/240v	240v	120/240v	
EH9*	9	30,708	0.20/0.50	30/30	4	8	52	58	60	60	1 @20x20x1
EH14*	13.5	46,062	0.20/0.50	40/40	4	8	76	81	80	90	1 @20x20x1
EH18*	18	61,416	0.20/0.50	40/45	4	8	99	105	100	125	1 @20x20x1
EH23*	22.5	76,770	0.20/0.50	55/60	4	8	123	128	125	150	1 @20x20x1
EH27*	27	92,124	0.20/0.50	60/65	4	8	146	152	150	175	1 @20x20x1

*D Direct Drive, 1/2HP, 4 speed motor, 240v, or 120v. Delhi G10-8 or Airdex 1020-800-5 DDblower.

*DS Direct Drive, 1/2HP, 3 speed motor, 240v. G10-8 or 1020-800-5 direct drive blower.

*B Belt Drive, 1/2HP, 240v or 120v, 1725 rpm motor. G10-8 or 1020-800-5 belt drive blower.

EH10 to EH30 elements are 5kW, 240 volts. EH9 to EH27 elements are 4.5kW, 240 volts. Control circuit is 24 volts. Blower motor fuse: 120v - CRN15 type D time delay. 240v - 2 @ TRM8 miniature time delay.

CLEARANCE TO COMBUSTIBLES

The Newmac EH Electric Furnace may be installed in the up-flow, down-flow, horizontal-left or horizontal-right positions with the following clearances to combustibles:

Sides	0"
Rear	0"
Front (For Servicing)	24"
Warm Air Plenum and Duct	0"

Locate the furnace to provide:

- Best heat distribution
- Shortest supply cable
- Least interference with present or future plans.

INSTALL TO CODE

This furnace shall be installed in accordance with the CSA Standard C22.1, Canadian Electric Code, and the requirements of the authority having jurisdiction. These instructions are intended as a general guide and do not supersede local codes. Consult local authorities before installation.

POWER CABLE

Use 75°C copper supply sized according to the minimum ampacity. This should be connected to a separate fused disconnect switch to power the furnace. Suitable ground must be provided.

RETURN AIR AND FILTER RACK

The filter rack may be mounted on either side, the bottom or the back of the appliance. Position the rack so that there is easy access to change the filter.

WARM AIR

Before installing the plenum, look into the furnace and check the heating elements to ensure that no damage has occurred and that they are free of foreign material.

THERMOSTAT and ANTICIPATOR

Should be installed according to the instructions packed with it and connected to the 24 volt terminals on the front of the appliance. The heat anticipator should be set to 0.4 amps.

BLOWER SPEED AND STATIC PRESSURE

The Newmac EH Electric Furnace is tested and approved by CSA for static pressures of 0.20 to 0.50 ins wc.

The 0.20 ins wc static pressure setting is for normal use and the units are factory equipped with the blowers set to provide this.

The 0.50 ins wc static pressure setting is for air conditioning. The installer should set the required blower speed - see table below.

Set the speed of the belt-drive-blower units by adjusting the motor pulley. Adjust this pulley to give the recommended air temperature rise.

SEQUENCE OF OPERATION

- As the room temperature drops, the thermostat contacts will close and energize the heating element on the first sequencer.
- After approximately 20 seconds, the first set of contacts in the sequencer will close, bringing on the #1 element. At the same time the circulating blower will start.
- After approximately 40 seconds, the #2 element will come on.
- Depending on the model, and if the furnace is set to Hi, #3, #4, #5, and #6 elements will come on in sequence. See below for more information on the Hi/Econo switch setting.
- When the room thermostat is satisfied, it will break contact. All the elements will turn off in random sequence. The blower will stop when the last element shuts off.

HI/LO CONTINUOUS FAN SWITCH

This is located on the front of the furnace and provides the homeowner with the option of having the circulating blower run continuously at high or low speed. This control does not affect the normal heating and cooling cycles of the furnace.

HI/ECONO HEAT SWITCH

- This switch is provided on some models. It is located on the front of the furnace and provides the homeowner with the option of manually increasing or reducing the heating power of the furnace. It can be used to manually switch from "Hi" to "Econo" if less heating power is temporarily desired, depending on the outdoor temperature.
- This switch can also be controlled automatically by a suitable multi- or two-stage thermostat connected to the W1 (Econo) and W2 (Hi) terminals. Set the switch to "Econo" if a two stage or multi-stage thermostat is used.
- If a standard thermostat is connected across W1-R, a remote switch or an outdoor temperature switch can be connected across OT-W2 to switch from "Econo" to "Hi" as the outdoor temperature drops. Leave the furnace switch in "Econo" if a remote or outdoor temperature switch is used.

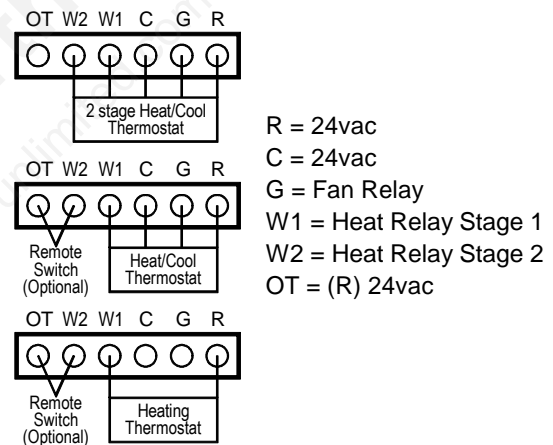

MAINTENANCE

To maintain the performance of the furnace, replace or clean the air filter monthly.

HOMEOWNER

If you, the homeowner, suspect the furnace is not operating properly, or if there is no heat, do not tamper with the furnace. Have a qualified service person check out the furnace installation.

BLOWER REMOVAL

Turn off the main electricity power supply before servicing the furnace.

Open the centre access panel to disconnect the wiring to the blower motor

Open the blower access panel. Carefully unscrew the bolt(s) holding the blower assembly in place, and remove the entire blower/motor assembly by sliding it out through the access opening.

STANDARD BLOWERS

MODEL	STATIC PRESSURE INS WC	VARIABLE SPEED MOTOR PULLEY (TO)	BLOWER PULLEY INS	BELT T INS	DIRECT DRIVE SPEED	CFM BELT DRIVE	CFM DIRECT DRIVE	APPROX TEMP RISE °F DIRECT
EH10*	0.20	3-1/4" (0)	6	40	Lo	1,400	900	35
	0.50	3-1/4" (2)	5	38	Lo	1,200	900	35
EH15*	0.20	3-1/4" (0)	6	40	MLo	1,400	1,100	45
	0.50	3-1/4" (2)	5	38	MLo	1,200	1,000	45
EH20*	0.20	3-1/4" (0)	6	40	MHi	1,400	1,300	50
	0.50	3-1/4" (2)	5	38	MHi	1,200	1,200	50
EH25*	0.20	3-1/4" (0)	6	40	MHi	1,400	1,300	60
	0.50	3-1/4" (2)	5	38	MHi	1,200	1,200	65
EH30*	0.20	3-1/4" (0)	6	40	Hi	1,400	1,400	65
	0.50	3-1/4" (2)	5	38	Hi	1,200	1,300	70
EH9*	0.20	3-1/4" (0)	6	40	Lo	1,400	900	30
	0.50	3-1/4" (2)	5	38	Lo	1,200	900	30
EH14*	0.20	3-1/4" (0)	6	40	MLo	1,400	1,100	40
	0.50	3-1/4" (2)	5	38	MLo	1,200	1,000	40
EH18*	0.20	3-1/4" (0)	6	40	MHi	1,400	1,300	40
	0.50	3-1/4" (2)	5	38	MHi	1,200	1,200	45
EH23*	0.20	3-1/4" (0)	6	40	MHi	1,400	1,300	55
	0.50	3-1/4" (2)	5	38	MHi	1,200	1,200	60
EH27*	0.20	3-1/4" (0)	6	40	Hi	1,400	1,400	60
	0.50	3-1/4" (2)	5	38	Hi	1,200	1,300	65

* = B for belt-drive blower and D for direct-drive blower. Note actual cfm and rise are installation dependent.

HIGH CFM (3 SPEED) BLOWER

MODEL	STATIC PRESSURE INS WC	DIRECT DRIVE SPEED	CFM	APPROX TEMP RISE °F
EH10DS	0.20	Lo	1,000	30
	0.50	Lo	900	35
EH15DS	0.20	Med	1,250	40
	0.50	Med	1,150	40
EH20DS	0.20	Med	1,250	50
	0.50	Med	1,150	55
EH25DS	0.20	Hi	1,700	45
	0.50	Hi	1,450	55
EH30DS	0.20	Hi	1,700	55
	0.50	Hi	1,450	65
EH9DS	0.20	Lo	1,000	30
	0.50	Lo	900	30
EH14DS	0.20	Med	1,250	35
	0.50	Med	1,150	35
EH18DS	0.20	Med	1,250	45
	0.50	Med	1,150	50
EH23DS	0.20	Hi	1,700	45
	0.50	Hi	1,450	50
EH27DS	0.20	Hi	1,700	55
	0.50	Hi	1,450	60

DS for direct-drive high cfm 3 speed blower. Note actual cfm and rise are installation dependent.

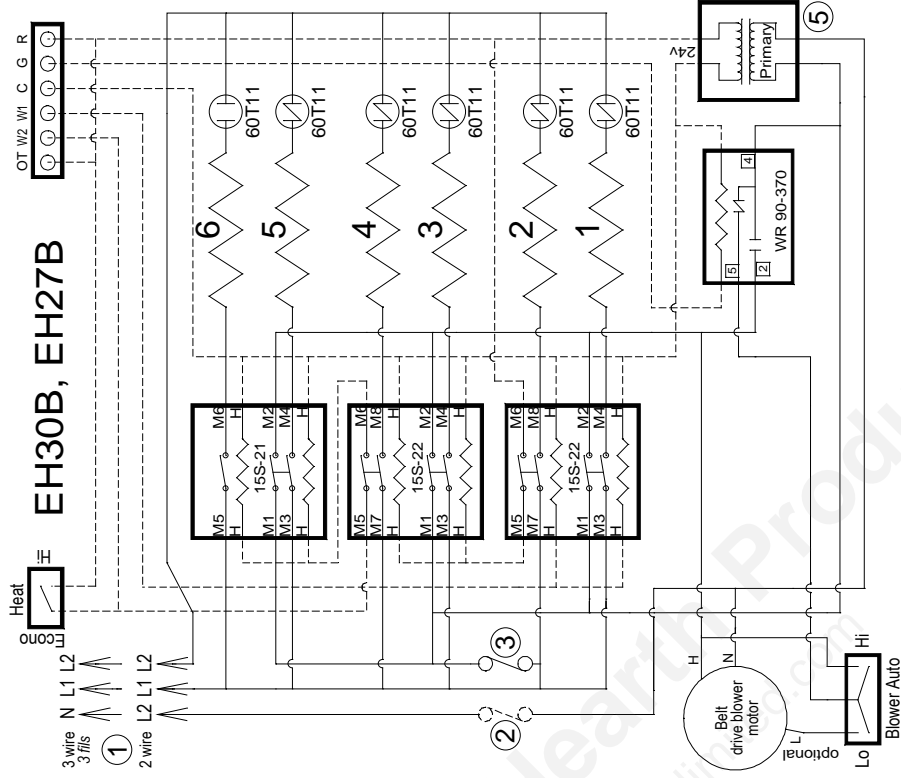

- 2 wire models (240v motor)
240v, 1ph, 60Hz**
- 1 Connect to L1 and L2
 - 2 TRM8 mini fuse
 - 3 TRM8 mini fuse
 - 4 WR90-374 heat relays
 - 5 240/24v transformer
 - 6 See motor lead colours

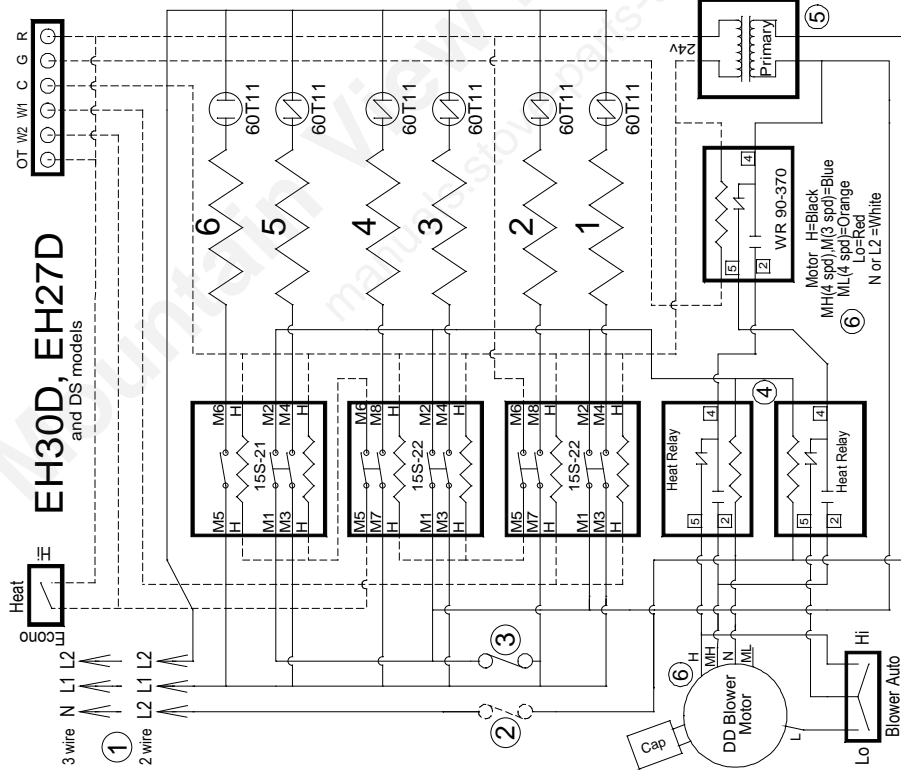

- 3 wire models (120v motor)
120/240v, 1ph, 60Hz**
- 1 Connect to N, L1, and L2
 - 2 No fuse
 - 3 CRN15 type D fuse
 - 4 WR90-372 heat relays
 - 5 120/24v transformer
 - 6 See motor lead colours

WIRING DIAGRAMS - EH30, EH27

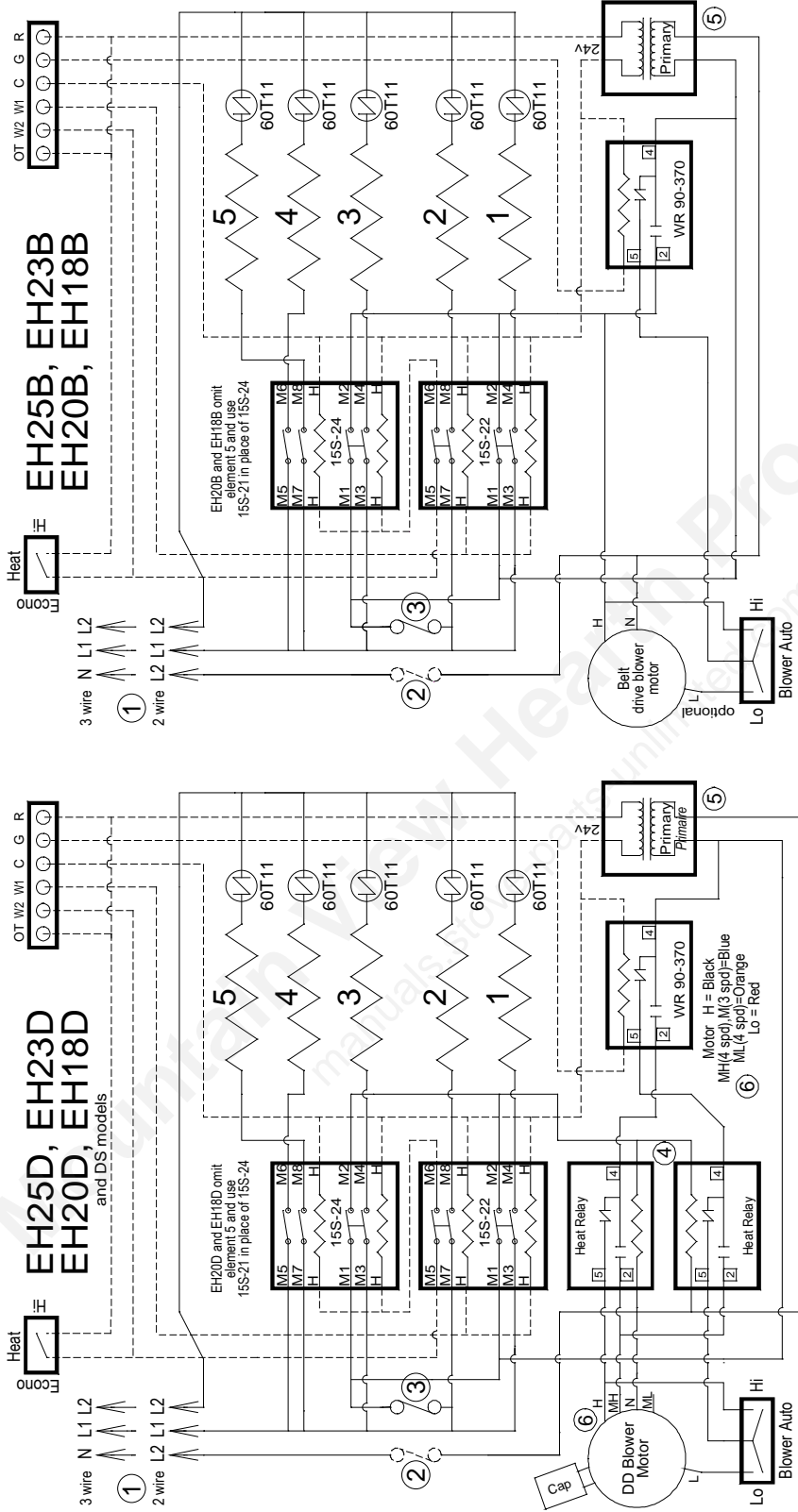

- 2 wire models (240v motor)
240v, 1ph, 60Hz**
- ① Connect to L1 and L2
 - ② TRM8 mini fuse
 - ③ TRM8 mini fuse
 - ④ WR90-374 heat relays
 - ⑤ 240/24v transformer
 - ⑥ See motor lead colours

- 3 wire models (120v motor)
120/240v, 1ph, 60Hz**
- ① Connect to N, L1, and L2
 - ② No fuse
 - ③ CRN15 type D fuse
 - ④ WR90-372 heat relays
 - ⑤ 120/24v transformer
 - ⑥ See motor lead colours

EHxxD = 4 speed direct drive
 EHxxDS = 3 speed direct drive
 EHxxB = Belt drive

WIRING DIAGRAMS - EH25, EH23, EH20, EH18

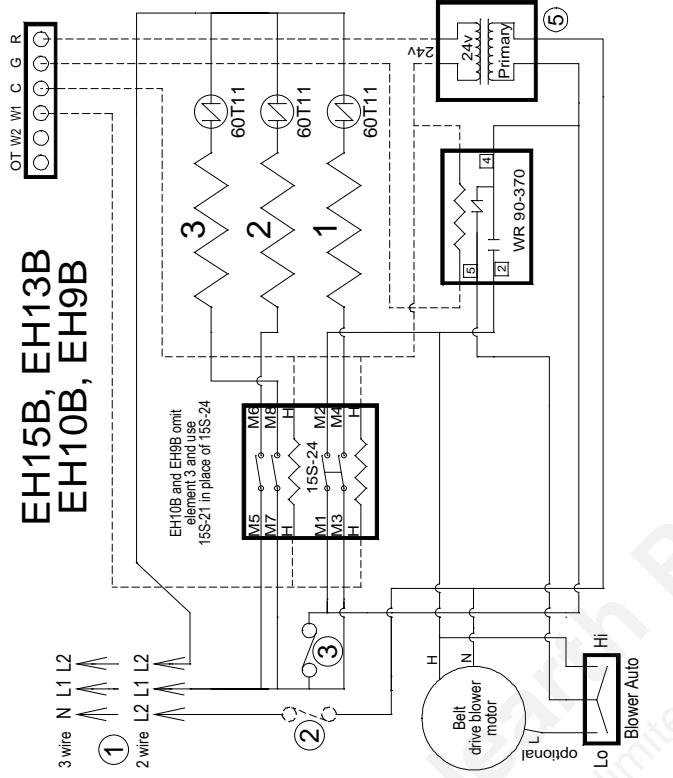

- 2 wire models (240v motor)
240v, 1ph, 60Hz**
- ① Connect to L1 and L2
 - ② TRM8 mini fuse
 - ③ TRM8 mini fuse
 - ④ WR90-374 heat relays
 - ⑤ 240/24v transformer
 - ⑥ See motor lead colours

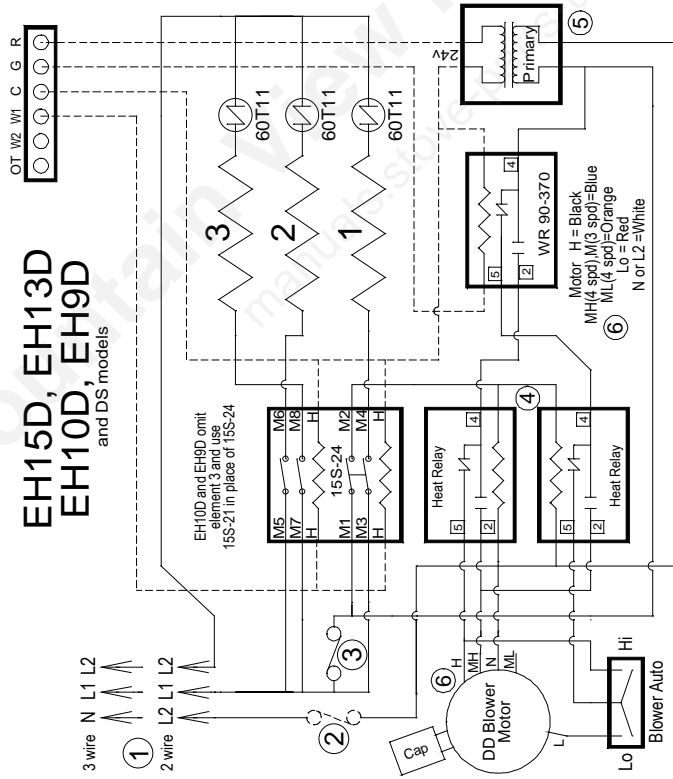

- 3 wire models (120v motor)
120/240v, 1ph, 60Hz**
- ① Connect to N, L1, and L2
 - ② No fuse
 - ③ CRN15 type D fuse
 - ④ WR90-372 heat relays
 - ⑤ 120/24v transformer
 - ⑥ See motor lead colours

EHxxD = 4 speed direct drive
EHxxDS = 3 speed direct drive
EHxxB = Belt drive

WIRING DIAGRAMS - EH15, EH13, EH10, EH9

EH REPLACEMENT PARTS LIST

PART NO.	DESCRIPTION	PART NO.	DESCRIPTION
2020008	1/2 Hp Direct Drive Motor - 4 Speed (120v)	3090334	Heating Element Blank Cover
2020009	1/2 Hp Direct Drive Motor - 4 Speed (240v)	4120442	Front Access Panel (Wiring)
	1/2 Hp Direct Drive Motor - 3 Speed (240v)	4120438	Front Panel - Switch
2020003	1/2 Hp Belt Drive Motor (120v)	4120257	Side Panel RH (36" DD models)
	1/2 Hp Belt Drive Motor (240v)	4120259	Side Panel LH (36" DD models)
2240001	Variable Speed Motor Pulley 3-1/4" X 1/2"	4120260	Rear Panel (36" DD models)
2240005	Blower Pulley - 5" (0.5"Wc Static)	4120258	Blower Access Door (for 36" DD models)
2240006	Blower Pulley - 6" (0.2"Wc Static)	4120445	Side Panel RH (40" BD models)
2240038	Blower Belt - 38" (For 5" Pulley)	4120437	Side Panel LH (40" BD models)
2240040	Blower Belt - 40" (For 6" Pulley)	4120436	Rear Panel (40" BD models)
4050280	10-8 Direct Drive Blower assembly complete	4120435	Blower Access Cover (for 40" BD models)
2040115	10-8 Direct Drive Blower	4120439	Air Filter Assembly
2040116	10-8 Belt Drive Blower c/w 5" pulley	4120434	Base Panel
4050281	10-8 Belt Drive Blower c/w motor hardware		
	Motor Belly Band assembly, 10"	2210047	Manual Instructions
4110214	Blower Legs (2)	2010008	Thermostat (heating only)
2010040	Capacitor - 5uF		
	Capacitor - 7.5uF		
2200121	Heating Element - 5kW, 240v	2200280	Switch - Blower, Hi/Lo Continuous
2200124	Heating Element - 4.5kW, 240v	2200258	Switch - Heat, Hi/Econo
2200117	Sequencer, 15S-21		
2200118	Sequencer, 15S-22	2200130	Thermo-O-Disc 60T11 312301Limit
2200119	Sequencer, 15S-24		
2200236	Fuse Holder (120v motor) for CRN15 fuse	2180006	20" x 20" air filter
2200282	Fuse Holder (240v motor) for TRM8 fuse		
2200237	15A Fuse (120v motor models) CRN15 type D		
2200283	8A Fuse (240v motor models) TRM8 miniature		
2010022	24v Transformer (120v model)		
2010084	24v Transformer (240v model)		
2010081	Cooling Relay (24v coil) WR 90-370		
2010082	Heating Relay (120v coil) WR 90-372		
2010083	Heating Relay (240v coil) WR 90-374		
2200232	240v terminal block (all models)		



Limited Warranty

Subject to the following provisions, Newmac Mfg. Inc. ("Newmac") warrants the heating unit under normal use and repair against defects in workmanship or material for a period of one year from the date of installation.

Under this warranty, Newmac will replace or repair any defective part at no cost or expense to you except for the cost of delivery and labour in the removal of the defective part and the installation labour of the replacement part.

This warranty is void if the unit is not installed, operated, maintained, and cleaned according to the owner's manual.

The heating unit must be installed by a competent, qualified installer in accordance with our installation instructions, applicable codes and the National Warm Air Heating and Air Conditioning Association Standards or generally accepted equivalent standards. The warranty is void if any alteration is made to the heating unit without written authorization by Newmac. This warranty is the only warranty made by Newmac. Newmac does not authorize any person or company to provide any other warranty or to assume any further obligation in connection with the sale of this heating unit on its behalf. This warranty shall not apply to damage of the heating unit caused by misuse or failure to maintain the heating unit properly. This warranty does not apply to the installation or wiring not integral to the heating unit. The operation of the heating unit in a corrosive atmosphere (such as concentration of acids or halogenated hydrocarbons) is considered misuse and voids this warranty.

This heating unit must be used and cared for in accordance with the instruction manual. The purchaser is responsible for required periodic maintenance such as changing or cleaning air filters and lubrication of components. See instruction manual for details.

Newmac shall not be responsible for any consequential damage however caused whether by a defect in the heating unit or any part thereof warranted hereunder or by the negligence of any person.

If the heating unit requires service, contact the dealer who installed the equipment originally, or an alternate qualified and registered heating dealer or electrician. As stated herein, Newmac does not assume responsibility for costs of delivery and labour involved in the replacement of defective parts. Unless otherwise directed by Newmac, defective parts must be returned to the Newmac plant; freight prepaid. Collect charges will not be accepted. Replacement parts will be supplied F.O.B. our factory.

Whenever requesting service, please be sure to give the model and serial numbers located on the rating plate of your heating unit.

This warranty is not effective unless the warranty registration card is properly filled out with all of the required information and received by Newmac at the address below within thirty (30) days of the installation date.

Keep this warranty certificate and the instruction manual for future reference.

Warranty Registration

PLEASE PRINT OR TYPE

Owner's name

Address of Installation

Date of Installation

Dealer's name

Dealer's address

Furnace serial number Furnace Model Number

Newmac Mfg. Inc, P.O. Box 9, 208 Lancaster Crescent, Debert, Nova Scotia, Canada, B0M 1G0