

OSBURN 1050

Clean Air. Always.

*environment
friendly*



GAS & WOOD

HEARTH SYSTEMS

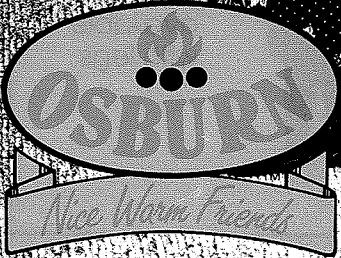

From Osburn, manufacturer of clean burning, efficient woodstoves and a world leader in non-catalytic combustion, comes the OSBURN 1050. Osburn's research and development team has created an improved combustion system in this woodstove, which delivers a wide BTU range and is tested to 1990 EPA standards. Easy to operate, the OSBURN 1050 promises a clean burn. Everytime!

OSBURN 1050

Innovative production methods and superior craftsmanship are combined in this handsome hard-worker, accented with beautiful brass trim. Large glass door of Osburn's 'Self-cleaning Glass' is available in your choice of four hand-etched designs.

EFFICIENCY

High technology non-catalytic combustion design burns clean, everytime! Gives more heat with less wood, so you're guaranteed of a good overnight burn.* *

EASY TO OPERATE

The Osburn 1050 features an up-front, easy to use control.

FEATURES

- ★ Certified to EPA standards
- ★ Non-catalytic
- ★ 1.5 cubic foot firebox
- ★ 13-7/8" height under baffle
- ★ Firebrick lined and removable baffle
- ★ Outside combustion air
- ★ Built in ash pan on pedestal model
- ★ Leg model available
- ★ U.S.A. mobile home approved
- ★ Provides more heat, uses less wood

- * Values based on single fuel load. Actual values will be higher with increased fuel loading.
- * May vary subject to location in home, locality, heat loss factors, climate and fuels.



GAS & WOOD
HEARTH SYSTEMS

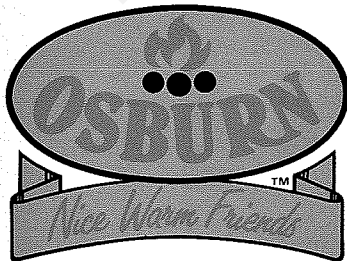

MANUFACTURED IN VICTORIA, B.C. CANADA

AUTHORIZED DEALER



EMISSIONS

U.S. EPA RATING

- ★ 6.6 g/hr. weighted average
- ★ 10600 to 42900 BTU/hr.*

AUSTRALIA

- ★ 5.0 g/Kg weighted average

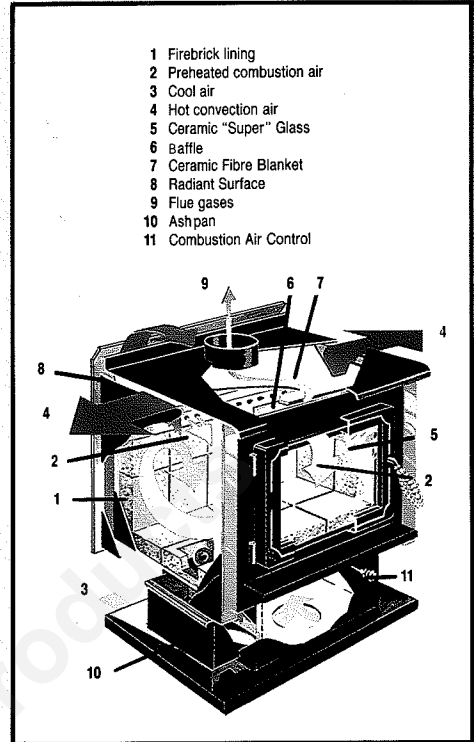

OSBURN 1050	COOKTOP HEIGHT	COOKTOP WIDTH	DEPTH	FLUE SIZE	
DIMENSIONS	28" (710 mm)	24" (610 mm)	22" (560 mm)	6" (150 mm)	
MINIMUM HEARTH SIZE	WIDTH 36" (915 mm)		DEPTH 43" (1095 mm)		
CLEARANCES TO COMBUSTIBLES	RESIDENTIAL	MOBILE HOME AND RESIDENTIAL CLOSE CLEARANCES			
	SINGLE WALL PIPE	PIPESHIELD ON SINGLE WALL PIPE	DOUBLE WALL CONNECTOR D.V. DVL	DL42A AND PIPESHIELD	BENJA FLUE KIT
	CANADA & U.S.A.	CANADA & U.S.A.	CANADA & U.S.A.	CANADA & U.S.A.	AUSTRALIA
FROM STOVE EDGE					
BACK WALL	14" (355 mm)	10" (255 mm)	8" (205 mm)	3" (75 mm)	4" (100 mm)
SIDE WALL	15" (380 mm)	14" (355 mm)	12" (305 mm)	15" (380 mm)	16" (400 mm)
CORNER	12" (305 mm)	12" (305 mm)	6" (150 mm)	9" (230 mm)	6" (150 mm)
BTU NET OUTPUT: May vary subject to fuel used, moisture content, fuel load and loading technique.	MINIMUM BTU/HR. OUTPUT	MINIMUM KW OUTPUT	MAXIMUM BTU/HR. OUTPUT	MAXIMUM KW OUTPUT	
	10000	2.9	50000 +	14.6 +	
SHIPPING WEIGHT 270 lb. - 123 Kg.					

The 1050 is also above approved and has been safety tested with Security Chimney, Selkirk Metalbestos, Jakes-Evans, Simpson Dura-Vent, Ameri Tec, Shamic and Benja flue kits. Consult instruction manuals for appropriate clearances.



• Wilderness



• Whales



• B.C. Dogwood



• Thunderbird

ETCHED GLASS Osburn's optional hand-etched door glass in 4 designs:

WARRANTY:

All Osburn woodstoves and fireplace inserts carry a five year limited warranty on workmanship and materials. See owner's manual for details.

Some dimensions may change from time to time as Osburn strives constantly to improve its products, to assure you of a top quality product that will function safely and efficiently for years to come.

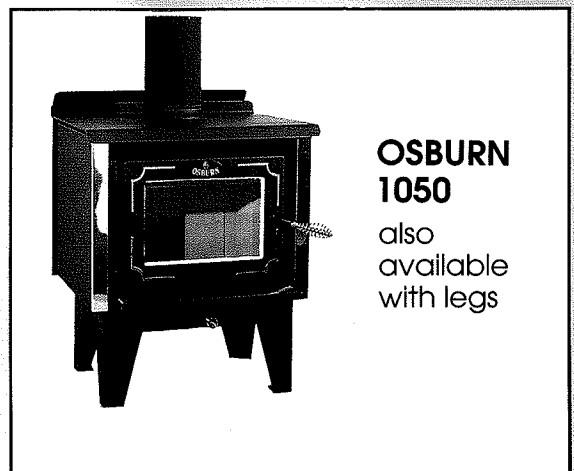

**OSBURN
1050**

also available with legs

1050 MODEL STOVE

OWNER'S INSTRUCTION MANUAL

READ ALL INSTRUCTIONS BEFORE INSTALLING OR OPERATING UNIT

SAVE THESE INSTRUCTIONS

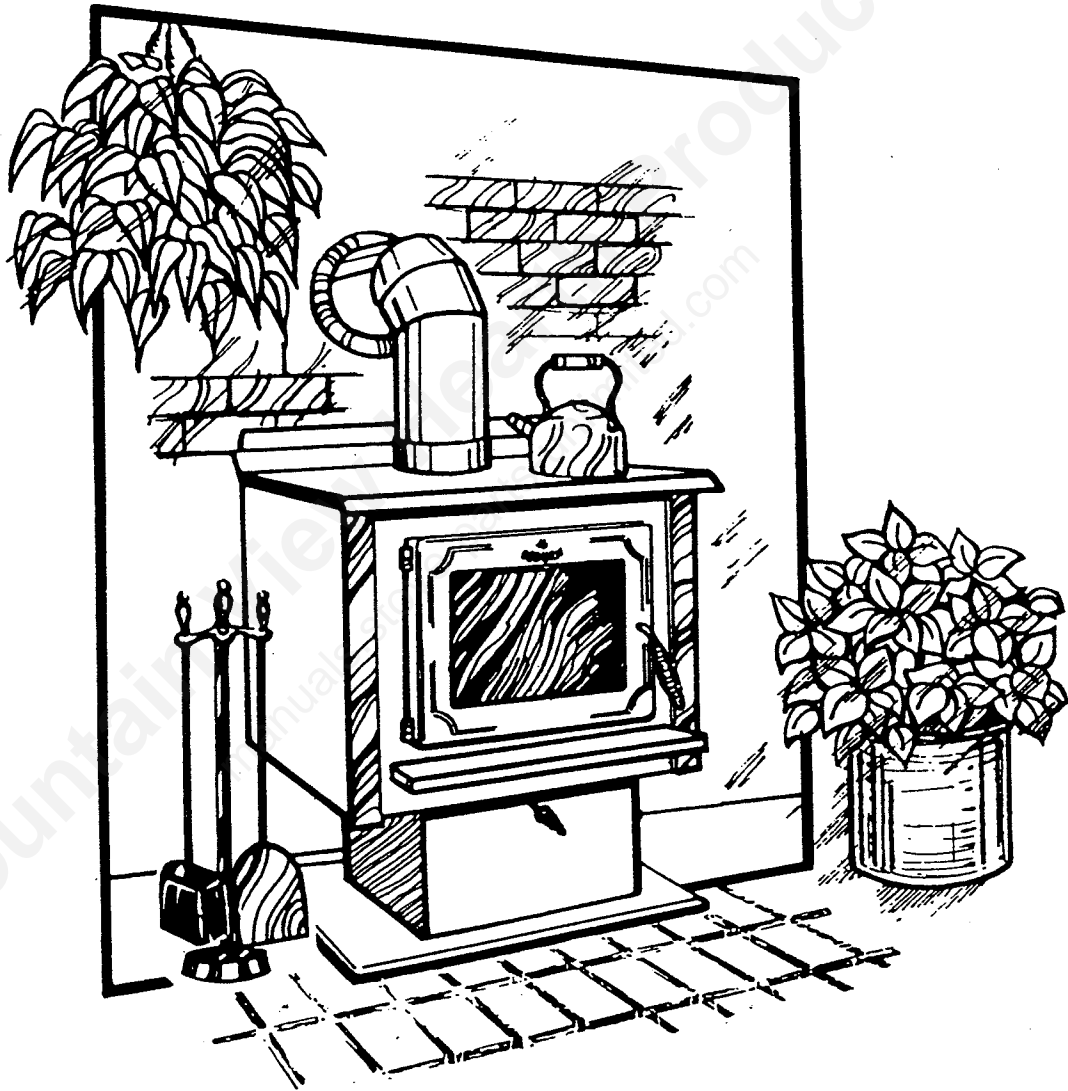

OSBURNTM
GAS & WOOD
HEARTH SYSTEMS

CONTENTS

INSTALLATION	1
Safety Information	1
Chimney Installation Notes	2
Residential Installation Instructions	3
Clearances To Combustibles For Model 1050A	4
Close Clearance to Combustibles	5
Clearances To Combustibles For Model 1050P	5
Mobile Home & Close Clearance Installations	7
Close Clearance Kit	10
Chimney Systems Installation Instructions	12
Outside Combustion Air Installations	14
Pipe Shield Installations	15
OPERATION	16
Safety Information	16
Notes About First Fires	17
Lighting A Fire	17
Maintaining The Fire	18
MAINTENANCE	19
Care & Cleaning	19
Glass Replacement	19
Ash Removal Using Ash Drawer	20
Chimney Cleaning	20
Baffle Removal	21
Wood Fuel Information	21
Wood Moisture Test	22
TROUBLE SHOOTING	22
SPECIFICATIONS	23
OSBURN LIMITED WARRANTY	24
Q.A. CHECKLIST	27

INSTALLATION

The Osburn Model 1050 is certified for both residential and mobile home (mobile home certified in USA only) installations, as a freestanding space heater, providing installation and usage is according to the information given in this manual.

This Stove is designed for safe operation. Altering or modifying the unit, or the installation without proper authorization will void the certification, warranty, and safety listing and may result in a safety hazard.

DO NOT abuse the unit, either by **over firing** or by using wood or combustibles with **salt content**, or harmful chemicals. Misuse is not covered by warranty.

SAFETY INFORMATION

NOTE: This appliance is not recommended for use in a home if an occupant has any respiratory or any other related problems.

1. It is important to follow the installation and operation instructions. An improperly installed or operated stove could result in a safety hazard or fire, or damage to the unit which would not be covered by the warranty. Contact local building or fire officials about restrictions and installation requirements in your area. You should be familiar with the installation and be sure that the work is done in accordance with this manual.
WARNING: Do not install in a sleeping room.
2. Where lesser clearances are desired, consult your local authority as regulations may vary regarding the use of clearance reducing devices. Listed wall and floor shields are available to reduce clearances, and most building codes provide information on materials which may be used to reduce clearances.
3. Maintain at least the minimum clearances to combustible material as specified in this manual. Clearances are measured to the nearest part of the stove (i.e. top edge on the side). Clearances to any combustibles when measured directly out from the front and up from the top of the stove, must be a minimum of 48" (1219mm).
4. Maintain at least the minimum floor protection for combustible floor materials as specified in this manual. Floor protection to the front is to be measured from the fuel loading door opening. Note that floor protection is required for spark and ash protection, but not for limiting floor temperatures from the radiant heat of the stove. These units were designed and safety tested so that without any protection, the floor would not overheat even under overfiring conditions. The hearth should be 18" (457mm) to the front and 8" (203 mm) to the sides and back for Canada. For the U.S., the hearth should be 16" (406mm) to the front and 8" (203mm) to the sides and rear.
5. The unit is not to be connected to any air distribution duct.
6. In any home, it is recommended that installation of a commonly available listed smoke detector or alarm is made. Normal operation of the stove will have no effect on the alarm.

7. The stove is to be connected only to a lined masonry chimney conforming to building codes for use with solid fuel or to listed factory built chimney suitable for use with solid fuel. Minimum chimney size is 16" (406mm) diameter. Maintain a 11' (3.4m) minimum overall height measured from the base of the appliance. Masonry and metal chimneys should be inspected for deterioration and to determine if they meet the minimum requirements, and be upgraded if necessary. The chimney must extend at least 3' (910mm) above the roof and at least 2' (610mm) above the highest point within an area of 10' (3m) of the chimney.

CAUTION: Do not fill the framed space around the chimney with insulation or any other material. Insulation placed in this area could cause adjacent combustibles to overheat.

8. The appliance should be connected to the main chimney by one of the following:
 - minimum 24 gauge black steel chimney connector pipe
 - minimum 25 gauge blued steel chimney connector pipe
 - Doublewall stove pipe

The chimney connector pipe must not pass through an attic or roof space, or closet, or similar concealed space, or a floor, ceiling, wall, or partition of combustible construction. If passing through a wall, ceiling, or into a masonry chimney, use either components listed for that specific use, or means according to accepted codes.

9. Do not use makeshift compromises during installation as they could be a safety hazard, and a fire could result.
10. Do not connect this appliance to a chimney or flue serving another appliance.

CHIMNEY INSTALLATION NOTES

The flue is a critical component to a satisfactory installation. Your Osburn stove will attain its best performance if installed with a chimney that generates proper draft. Draft is the force which moves air from the appliance up through the chimney. The amount of draft in your chimney depends on the length of the chimney, local geography, nearby obstructions, and other factors. If you test the draft, using a pressure gauge, the reading should be .05 - .07 inches of water at a medium high fire in the model 1050. Chimneys constructed outside of the home on an exterior wall should be avoided if possible, especially in colder climates. Outside chimneys may not draw as well and may downdraft, due to the difficulty in heating it up to operating temperature. Cooler chimneys will result in increased creosoting, less draft, and poorer performance. Draw or draft is proportional to overall chimney height, as well as to stack temperature, and therefore draw can be increased by installing additional chimney lengths, and by reducing heat loss from the chimney. Too much draft may cause excessive temperatures in the stove. A manual damper may be installed in the vertical connector pipe to help reduce excessive draft which in turn will increase burn time. Inadequate draft may cause backpuffing into the room and plugging of the chimney. For best results, use of a 6" (152mm) chimney extending vertically off the unit, or a masonry chimney which is located close to the appliance and connected with a short length of horizontal connector, is recommended. Restrictions, such as using more than 2 elbows, should be avoided, and any horizontal runs should be kept to a minimum length, especially with short chimneys.

NOTE: UNDER HIGH DRAFT CONDITIONS IT MAY BE REQUIRED TO PLACE TWO 1" x 8" METAL STRIPS ON TOP OF THE CERAMIC INSULATION BLANKET, IN FRONT AND BEHIND THE FLUE COLLAR. THESE METAL STRIPS WILL ACT AS WEIGHTS TO PREVENT THE INSULATION FROM BEING DRAWN TOWARD THE FLUE HOLE. THE METAL STRIPS (WEIGHTS) WILL BE LOCATED INSIDE THE FIREBOX WHEN PACKAGED.

If venting into an exterior chimney, best results will be obtained using a connector vertically off the unit to the highest possible point before elbowing off horizontally to the chimney. The unit must not be installed with insulated chimney connected directly to the appliance, for efficiency and safety reasons, since the connector is a primary source of heat transfer. A minimum connector length of 4' (1.2mm) is recommended for best results.

Ensure that all joints in the flue system are sealed, since any leaks will result in reduced performance as well as a possible safety hazard.

RESIDENTIAL INSTALLATION INSTRUCTIONS

1. If installed on a non-combustible floor the hearth area under the stove should extend at least 6" (152mm) beyond each side and to the back of the unit, and 18" (457mm) in front of the unit. If the stove is to be installed on top of a combustible floor it must be protected by a non-combustible material covering the hearth area for protection from sparks and ash. Refer to local codes for suitable floor protection materials. The stove should be placed to maintain the minimum clearances to combustible walls specified for the connector used.
2. Choose a location for the unit and locate it in position, maintaining proper clearances.

NOTE: If using pipe shields for closer clearances, refer to the pipe shields installation instructions.

Vertical chimney installation:

Suspend a plumb to the centre of the stove flue collar from the ceiling and mark the position on the ceiling. Determine if the chimney will pass between the roof joists, and if not, relocate the stove so that it will.

Alcove installation:

The minimum width and height of the alcove is 54" (1372mm) wide and 7' (2134mm) high. The maximum depth is 48" (1219mm). Security Doublewall connector and Security XSF or SF Ceiling Finish Support must be used for this installation, please also use the vertical chimney installation notes also. Also see the clearances chart for proper clearances. Before cutting a floor joist, roof joist or wall studs, consult a professional (ie: building inspector) to ensure structural integrity is maintained.

3. Mark the location for the required floor protection as noted in #1. Remove the unit, and install the floor protector if required. If outside air is to be used, install it now (refer to the instructions on outside air installation). Reinstall the unit.
4. When connecting to a factory built chimney, ensure that the factory built chimney is installed according to the manufacturer's listed instructions. Clean the chimney if required. See also #11 of mobile home installation instructions.

5. Install sections of single wall or doublewall connector between the stove and the chimney. Secure all chimney connector pipe joints with three (3) sheet metal screws. Chimney connector pipe and chimney must be installed with the male or crimped end down, in order to prevent creosote dripping outside the chimney joints. If non-telescopic sections are to be used, they must be cut to length, allowing for overlap. Maintain chimney connector pipe clearances to combustible walls.

CLEARANCES TO COMBUSTIBLES FOR MODEL 1050A
For units equipped with ash drawer and heatshield

	MEASURED FROM OUTSIDE EDGE OF STOVE	MEASURED FROM CONNECTOR
(a) Using single wall pipe: Side Back Corner	A. 15" (380mm) B. 14" (355mm) C. 12" (305mm)	D. 24" (610mm) E. 20" (510mm) F. 22 1/2" (570mm)
(b) Using single wall with pipe shields: Side Back Corner	A. 14" (355mm) B. 10" (255mm) C. 12" (305mm)	D. 23" (585mm) E. 16" (405mm) F. 22 1/2" (570mm)
(c) Using Security Chimneys Ltd. DL42A doublewall pipe: Side Back Corner	A. 14" (355mm) B. 13" (330mm) C. 13" (330mm)	D. 22 1/2" (572mm) E. 19" (485mm) F. 23" (585mm)
(d) Alcove installation - Using Security Chimneys Ltd. doublewall pipe and Security Chimneys Ltd. SF ceiling finish support: Side Back	A. 14" (355mm) B. 13" (330mm)	D. 22 1/2" (570mm) E. 19" (485mm)

**CLOSE CLEARANCE TO COMBUSTIBLES
THIS APPLIES TO UNITS EQUIPPED WITH A HEATSHIELD ONLY**

	MEASURED FROM OUTSIDE EDGE OF STOVE	MEASURED FROM CONNECTOR
<p>(e) Using Security Chimneys Ltd. DL42A with a 18" (460mm) pipe shield spaced 4" (100mm) from pipe shield and 21" (535mm) x 23" (585mm) stove shield, and an XSF or SF ceiling support:</p> <p>Side Back Corner</p>	<p>A. 20" (510mm) B. 3" (75mm) C. 13" (330mm)</p>	<p>D. 29" (740mm) E. 9" (230mm) F. 23" (585mm)</p>
<p>(f) Using Security Chimneys Ltd. DC2100 Doublewall connector and stove shield:</p> <p>Side Back Corner</p>	<p>A. 20" (510mm) B. 7" (180mm) C. 13" (330mm)</p>	<p>D. 28" (710mm) E. 12" (305mm) F. 23" (585mm)</p>
<p>CLEARANCES TO COMBUSTIBLES FOR MODEL 1050P This unit is not equipped with an ash drawer or heatshield</p>		
<p>(a) Using single wall pipe:</p> <p>Side Back Corner</p>	<p>A. 15" (380mm) B. 16" (406mm) C. 12" (305mm)</p>	<p>D. 24" (610mm) E. 20" (510mm) F. 22 1/2" (570mm)</p>
<p>(b) Using single wall with pipe shields:</p> <p>Side Back Corner</p>	<p>A. 14" (355mm) B. 12" (305mm) C. 12" (305mm)</p>	<p>D. 23" (585mm) E. 16" (405mm) F. 22 1/2" (570mm)</p>
<p>(c) Using Security Chimneys Ltd. DL42A doublewall pipe:</p> <p>Side Back Corner</p>	<p>A. 14" (355mm) B. 15" (380mm) C. 13" (330mm)</p>	<p>D. 22 1/2" (572mm) E. 19" (485mm) F. 23" (585mm)</p>
<p>(d) Alcove installation - Using Security Chimneys Ltd. doublewall pipe and Security Chimneys Ltd. SF ceiling finish support:</p> <p>Side Back</p>	<p>A. 14" (355mm) B. 15" (380mm)</p>	<p>D. 22 1/2" (570mm) E. 19" (485mm)</p>

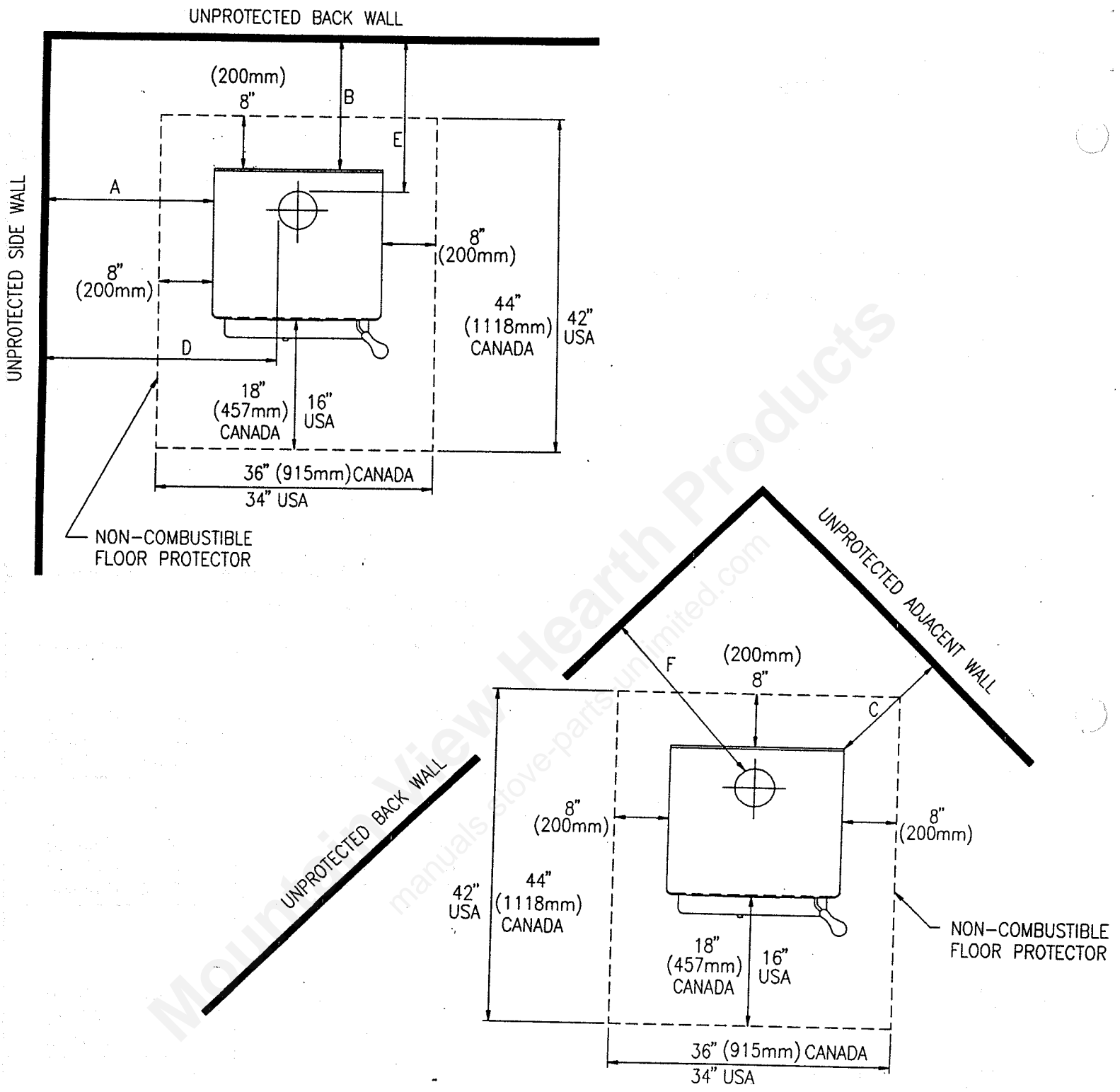

Figure 1

Stove clearances to combustibles (A, B, & C) measured from the top edges of the stove to rear heat shield. D, E, & F are measured from connector. Front clearance measured from the full loading opening.

ALCOVE INSTALLATION

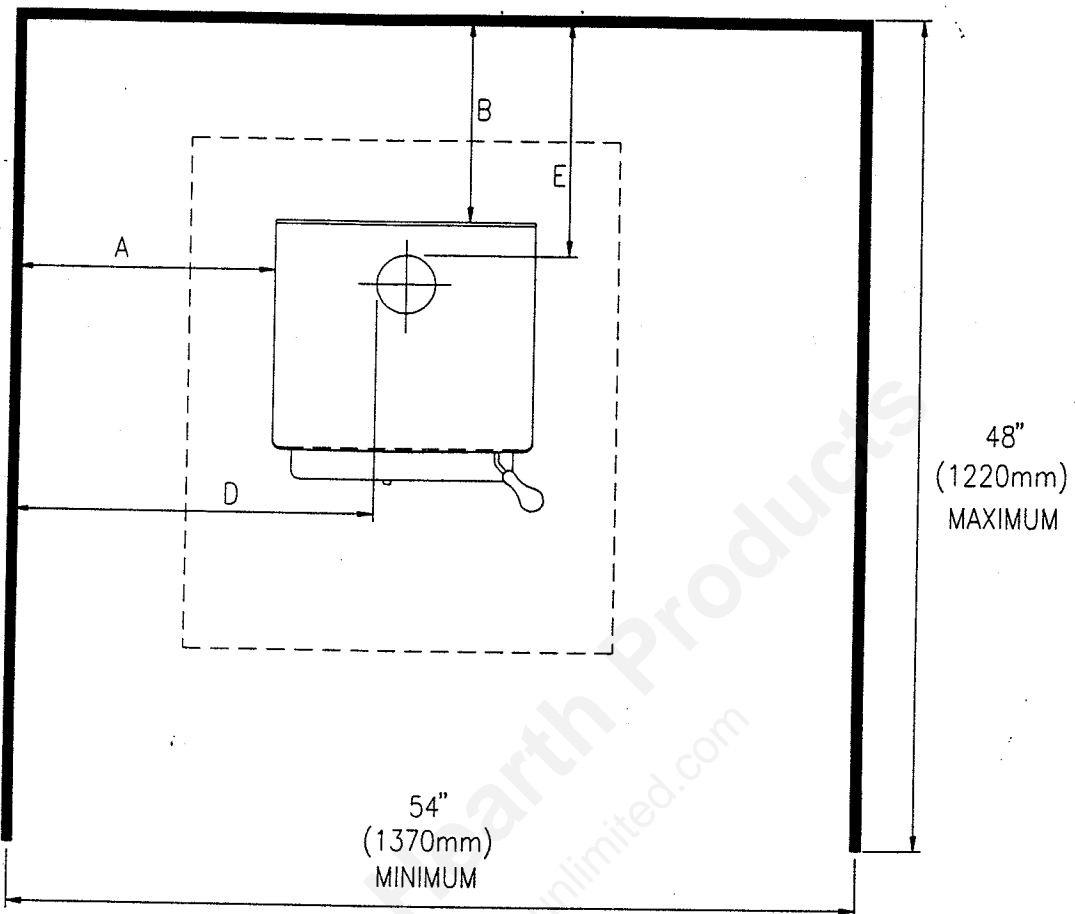

Figure 2

MOBILE HOME & CLOSE CLEARANCE INSTALLATION INSTRUCTIONS (U.S.A. ONLY)

1. Mobile home installations are only listed for the specific components outlined below. For safety reasons, do not substitute materials or components. **Caution:** The structural integrity of the mobile home floor, wall, and ceiling/roof must be maintained.
2. Mobile home units must be secured to the floor.
3. Do not install in a sleeping room.
4. Mobile home units must be provided with outside combustion air (see combustion air installation).
5. Mobile home units in the USA must be grounded to the frame of the mobile home using a #8 ground wire with the approved terminations and star washers.
6. The stove must be connected to a listed Security Chimneys Ltd. factory built chimney suitable for use with solid fuels and having a flue size of 6" (150mm) in diameter. The chimney must be a minimum of 12' (3700mm) in height from the hearth pad to the top of the chimney assembly. The stove must be connected to the chimney with Security doublewall connector of 6" (150mm) diameter.

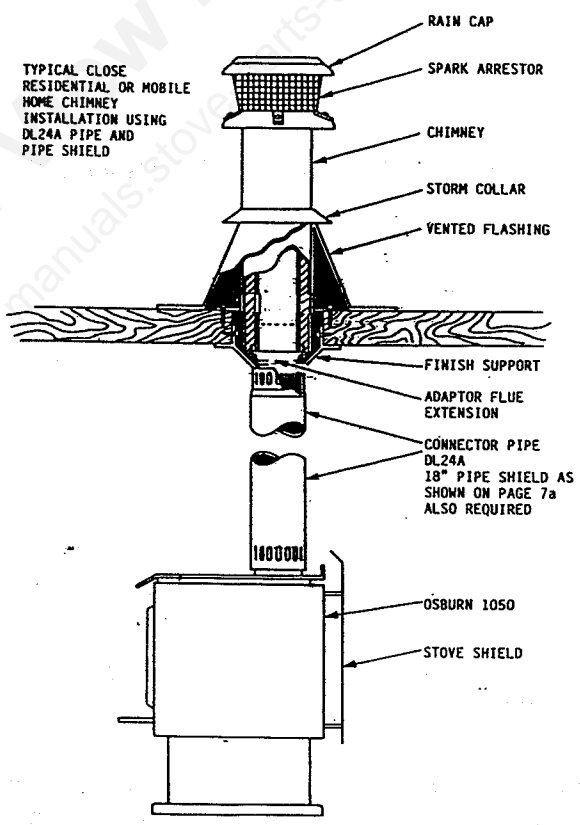
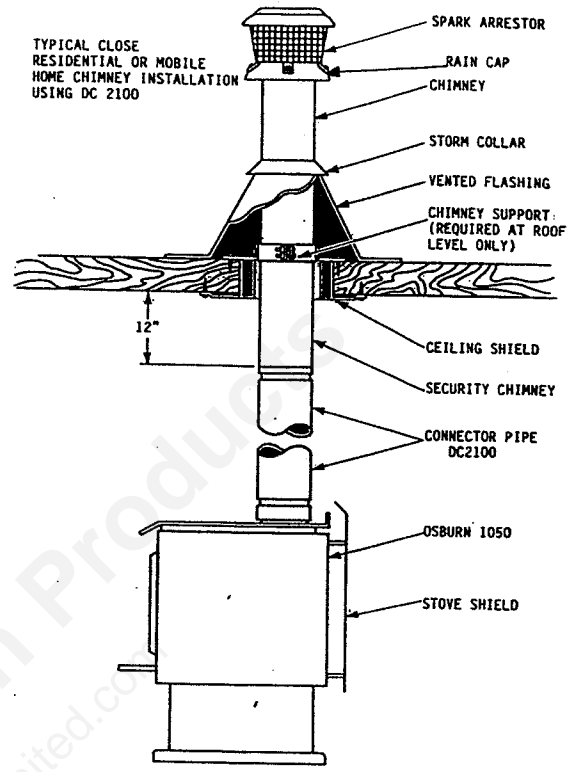
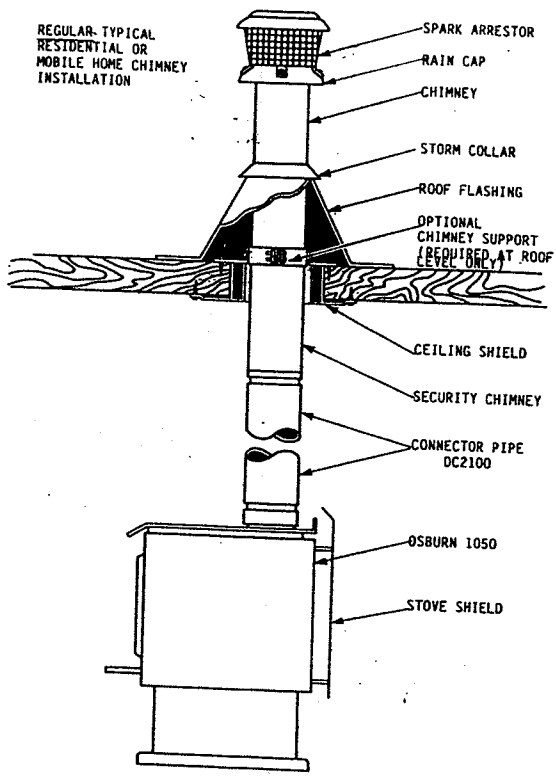

Figure 3

The doublewall connector must not pass through an attic or roof space, or closet, or similar concealed space, or a floor, ceiling, wall or partition of combustible construction. When connecting to a Security chimney, ensure that the chimney is installed in an approved manner, maintaining all clearances and using all parts as required by the chimney manufacturer. The chimney/connector systems, and the individual components, listed for the Osburn 1050 for mobile home applications are as follows:

(USA ONLY) SECURITY CHIMNEYS LTD.

COMPONENT	REGULAR	CLOSE	CLOSE
Chimney adaptor	P	P	-
Connector	DL42A	DL42A	DC2100
Flue Extension	P	P	-
Support	SF	SF	ST
Chimney*	ASHT	ASHT	ASHT-12" into room
Roof Flashing	F, FA, or FB	FAMH	FAMH
Rain Cap	CPE	CPE	CPE
Radiation Shields	-	18" pipseshield & stoveshield	RSMH & stoveshield
*use 4' minimum length of 6" diameter			

Install these components according to the following instructions:

7. The floor must be protected by a non-combustible floor protector extending at least 6" (150mm) beyond each side and to the back of the unit and 18" (460mm) in front of the unit. Refer to local codes in case of disagreement with these instructions.
8. Choose a suitable location for the unit and locate it in position, maintaining proper clearances. Suspend a plumb line to the centre of the stove flue collar from the ceiling and mark the position on the ceiling. Determine if the chimney will pass between the roof joists and if not, relocate the stove so that it will.
9. Before cutting a roof joist, consult a professional (ie. building inspector) to ensure structural integrity is maintained.
10. Mark the location for the required floor protection as noted in #7. Remove the unit, and install the floor protector. Install the Osburn fresh air kit now, (refer to the instructions on outside air installation). Reinstall the unit. Secure the unit by prying out the two plastic plugs in the pedestal, and installing 3/8" x 3 1/2" (10mm x 85mm) lag bolts in the holes provided.

11. Ensure that the factory built chimney is installed according to the following instructions:
Clean the chimney if required.
- (a) Find the location where the chimney will pass through the roof. Cut and frame the hole 14 3/8" x 14 3/8" (365mm x 365mm) if using the SF ceiling support. Staple and seal the vapour barrier in the hole. Cut and frame the hole 12" x 12" (300mm x 300mm) if using the RSMH.
 - (b) From below, push the support into the framed hole. Nail the support to the framed box using twelve 3" (75mm) spiral nails, or screw the RSMH to the ceiling if SF is not being used.
 - (c) Attach the flue extension (or chimney adapter found in the support box) to the bottom of the first length of the chimney using the three metal screws provided. Put this chimney length in the support. Push it down firmly in place. NOTE: The visible coupling must be on top.

For RSMH installation, screw the ST chimney support onto the first length of chimney without the flue extension so that when the chimney is put in place through the framed hole and the RSMH shield, 10" (255mm) of chimney protrudes into the room. Screw the ST onto the roof where the support braces overlap the roof.

- (d) Put the roof flashing in place. Seal the joint between the roof and flashing with roofing pitch or tar. For sloping roofs, place the flashing under the upper shingles and on top of the lower shingles. Nail the flashing to the roof using roofing nails. Place the storm collar over the chimney and the flashing. Tighten it with the bolt supplied making sure that the joint is properly caulked. Make sure that the flashing is vented.
- (e) Fit the spark arrestor raincap to the top of the chimney. Secure it tightly in place.
- (f) From below, place the double-wall pipe in the stove flue. Extend the pipe until it comes in contact with the ceiling support and so that the pipe connector attached to the bottom of the insulated pipe goes inside the double wall pipe. When using the DC2100, extend the pipe until it comes in contact with the chimney. The DC2100 will lock into the bottom of the ASHT. Screw in a metal screw at the point where the telescopic sections overlap, and tighten the locking band to hold it in place. Secure all connecting pipe joints according to manufacturers instructions, maintain chimney connector clearances to combustible walls.

CLOSE CLEARANCE KIT

When installing at close clearance, the DL42A pipe must have a 18" (450mm) pipe shield screwed onto it. This pipe shield must be spaced 4" (100mm) out toward the back from the DL42A, and must be 3" (75mm) up from the cook top. Locate on the rear of the DL42A connector the 4" (100mm) spacers (see Figure 4) and drill them into the connector using a drill and the supplied hexhead self-tapping screws. Position the spacers so that the flat side faces the horizontal; that way the vertical rigidity will be maintained. Place the shield onto the spacers so that it curves around the pipe. Drill the other two hexhead self-tapping screws through both the 18" (450mm) pipe shield and the bent tab of the 4" (100mm) spacer.

If the stove is to be installed using the DL42A and DC2100 at the close clearances, ensure that it has a rear stove shield placed on it. To install the stove shield, place two 2 1/2" (63mm) screws through the top two holes of the shield (see Figure 4). Place two 2" (50mm) spacers over the screws, and turn the screws into the top two holes at the rear of the stove. In the same manner, turn the other two 12" (2 63mm) screws into the bottom two rear stove holes (see Figure 4).

CAUTION: DO NOT fill the framed space around the chimney with insulated or any other material. Insulation placed in this area could cause adjacent combustibles to overheat.

DO NOT CONNECT THIS UNIT TO A CHIMNEY SERVING ANOTHER APPLIANCE. DO NOT USE MAKESHIFT COMPROMISES DURING INSTALLATION AS THEY COULD BE DANGEROUS.

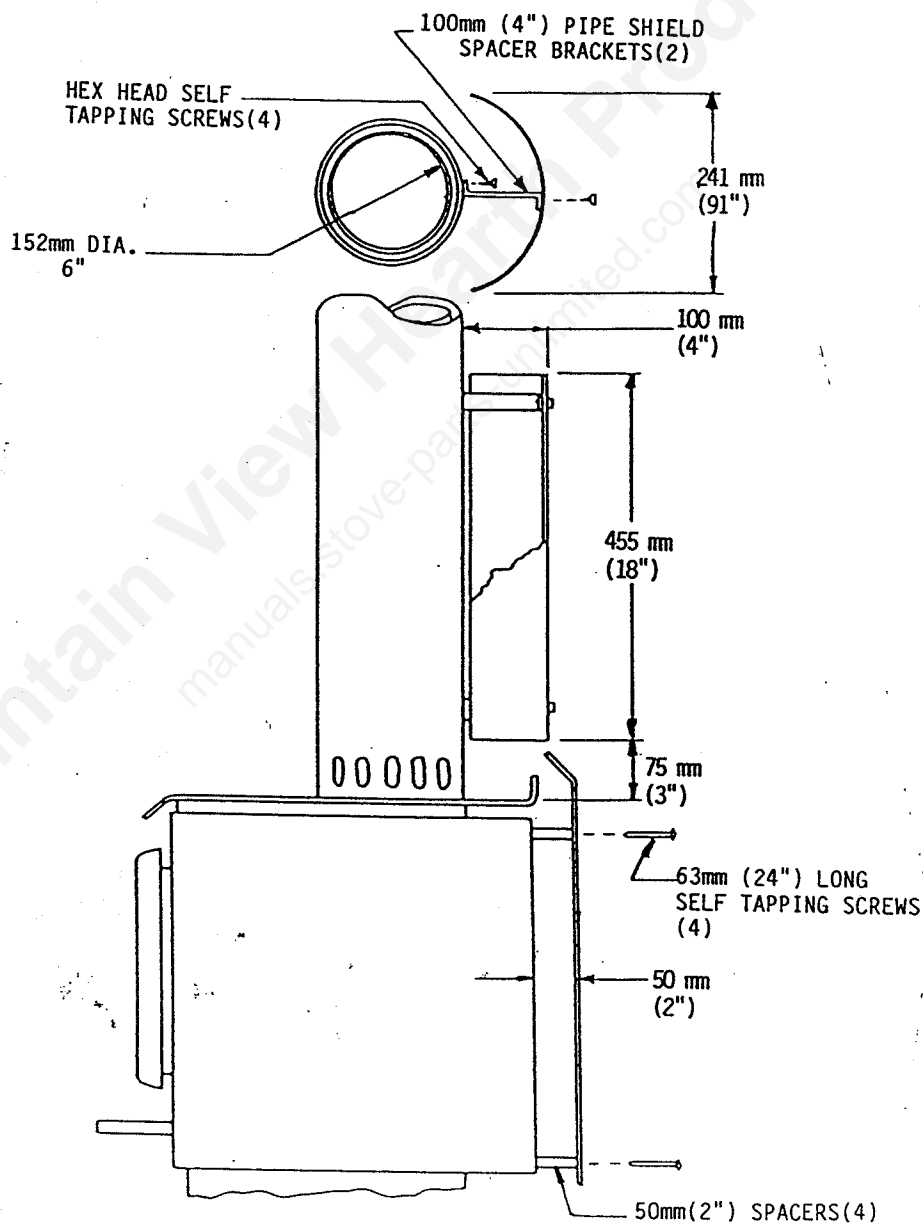

Figure 4

CHIMNEY SYSTEMS INSTALLATION INSTRUCTIONS

Dura-vent, Gsw, Selkirk Metalbestos, & Ameri-tec

1. Choose a suitable location for the unit and locate it in position, maintaining proper clearances shown below. Suspend a plumb line to the centre of the stove flue collar from the ceiling and mark the position on the ceiling. Determine if the chimney will pass between the roof joists and if not, relocate the stove so that it will.

CHIMNEY BRAND NAME	CLEARANCE TO STOVE		CLEARANCE TO CONNECTOR	
GSW				
Sidewall	14"	(355mm)	23"	(585mm)
Backwall	12"	(305mm)	17 3/4"	(450mm)
Corner	9"	(230mm)	20"	(510mm)
SELKIRK METALBESTOS				
Sidewall	13"	(330mm)	21 3/4"	(555mm)
Backwall	14"	(355mm)	19 3/4"	(500mm)
Corner	8"	(203mm)	19"	(485mm)
SIMPSON DURA-VENT				
Sidewall	12"	(305mm)	20 1/2"	(520mm)
Backwall	8"	(203mm)	13 1/2"	(345mm)
Corner	6"	(152mm)	17"	(430mm)
AMERI-TEC				
Sidewall	14"	(355mm)	22 1/2"	(570mm)
Backwall	12"	(305mm)	15 1/2"	(395mm)
Corner	9"	(230mm)	20"	(510mm)

2. Before cutting a roof joist, consult a professional (ie. building inspector) to ensure structural integrity is maintained.
3. Mark the location for the required floor protection. Remove the unit, and install the floor protector. Install the Osburn fresh air kit now, (refer to the instructions on outside air installation). Reinstall the unit. If in a mobile home, secure the unit by prying out the two plastic plugs in the pedestal, and installing 3/8" x 3 1/2" (10mm x 85mm) lag bolts in the holes provided.

4. Use only the component parts listed below:

COMPONENT	GSW	SELKIRK METALBESTOS	SIMPSON DURA-VENT	AMERI-TEC
Connector Pipe	JSP-6TL	6DS-AJ	6-DVL-CC-PEA	6DCC-T55
Chimney Adaptor	JSP6CA1	6DS-CPA	6-DVL-CC-C	6PL-SWA
Support/Shield	JSC6CCSB	6T-RSP /6T-MHJS	6-SDP-DCR-SB	6PL-CSRI/ 6PL-CSS
Chimney	Model SC (US)	Model SS II	6-SDP-SS (&-P)	6HS
Locking Band	JSC6SL	(With chimney)	N / A	N / A
Roof Flashing	JSC6ATC or JSC6AAF	6T-TF	6-SDP-F	6FFU
Storm Collar	JSC6ASC	6J-SC	6-SDP-SC	6SC
Rain Cap	JSC6RC (-MH when used in mobile homes)	6T-CT	6-SDP-DRC-C	6PL-MPC

Ensure that the chimney systems are installed according to the following instructions:

(a) Find the location where the chimney will pass through the roof. Cut and frame the hole according to the following table for the chimney brand and component being used.

BRAND

Dura-Vent
Jacks-Evans
Selkirk

HOLE SIZE

14 1/2" x 14 1/2" (370mm x 370mm)
12" x 12" (305mm x 305mm)
12" x 12" (305mm x 305mm)

Staple and seal the vapour barrier in the hole.

(b) From below, push the support or shield into the framed hole. The supports should protrude below the ceiling the following amounts: Dura-Vent 6" (150mm), Jacks-Evans 2" (50mm). Level the support and slit the corners where it extends above the roofline. Bend the support flaps (created from slitting) flush with the roof, and nail the support or flaps to the framing or roof using eight 3" (75mm) spiral nails, two per side. Screw the decorator trim to the ceiling around the support. Screw the Selkirk shield to the ceiling using four #8 x 1 1/4" (32mm) screws.

(c) i) **Jacks-Evans:** Attach the chimney adaptor to the bottom of the first section of chimney. Install the draw band at the bottom of the chimney by tightening the draw band bolt, and drilling four sheet metal screws through the draw band in to the outer casing of the chimney.

ii) **Selkirk:** Install the 6T-RSP to the first chimney section so that the chimney will protrude down past the shield and into the room by 3 1/2" (90mm). Attach the chimney adaptor to the bottom of the first length of the chimney.

- iii) Place the first chimney length in the support or through the shield. Push it down firmly in place. For the Dura-Vent, place the chimney connector into the bottom of the starter piece of chimney. Screw the 6T-RSP of the Selkirk on to the roof where the support braces overlap the roof. Place and secure the rest of the required chimney sections. Attach locking bands to the joints of the Jackes-Evans and the Selkirk chimney sections.
- (d) Put the vented roof flashing in place. Seal the space between the roof and flashing with roofing pitch or tar (Ameri-Tec uses unvented flashing). For sloping roofs, place the flashing under the upper shingles and on top of the lower shingles. Nail the flashing to the roof using roofing nails. Place the storm collar over the chimney and the flashing. Tighten it with the supplied nut and bolt. Seal it to the chimney with a suitable waterproof non-combustible mastic.
- (e) Fit the spark arrestor raincap to the top of the chimney. Secure it tightly in place.
- (f) From below, place the double-wall pipe in the stove flue collar and secure it to the collar with at least two screws. Install decorative trim pieces where necessary. Extend the pipe until it comes in contact with the chimney adaptor or the pipe connector, attached to the bottom of the insulated pipe, and goes inside the double wall pipe. Drill in a metal screw at the point where the telescopic sections overlap. For Selkirk pipe, tighten the locking band to hold it in place. Secure all connecting pipe joints according to manufacturers instructions, maintain chimney connector clearances to combustible walls.

CAUTION: DO NOT fill the framed space around the chimney with insulated or any other material. Insulation placed in this area could cause adjacent combustibles to overheat.

DO NOT CONNECT THIS UNIT TO A CHIMNEY SERVING ANOTHER APPLIANCE. DO NOT USE MAKESHIFT COMPROMISES DURING INSTALLATION AS THEY COULD BE DANGEROUS.

OUTSIDE COMBUSTION AIR INSTALLATIONS (REQUIRED FOR MOBILE HOMES)

Your Osburn stove is designed to use either room air or outside air for combustion. If you use outside air for combustion you can provide the outside air in close proximity to the unit (this is the recommended method) or directly to the unit.

If outside air is connected directly to the unit, be aware that in certain circumstances, flue reversal could possibly occur and this is **HIGHLY DANGEROUS**. The combustion air supply is not designed to handle hot flue gases and adjacent combustibles could ignite. Some signs of flue reversal occurring are smoke coming from the outside combustion air intake or flames going up the door and into the airwash air supply at the top of the door. If this occurs shut down the unit immediately and discontinue use until the problem is rectified.

Combustion air can be vented directly to the base of the appliance by cutting a 5" (125mm) hole in the floor under the unit, and then installing an Osburn "fresh air kit." The kit consists of a 16" (405mm) long, 5" (125mm) diameter duct with mesh rodent guard, mounting hardware, and insulation to close off the room air source. Additional lengths of 5" (125mm) diameter duct and elbows will be required if extending the ducting to an outside wall. Locate the center of the hole at the center of the pedestal base. If a vapour barrier is present, staple it to the inside of the 5" (125mm) diameter hole. To ensure no cold air leakage into the home and positive draw of air from the outside, install the 3" x 24" (76mm x 610mm) piece of fibreglass so that it will block off the notches on the backside of the base when the stove is placed on top. Make sure that the hearth is flat. If there are any cracks between the pedestal base and the hearth, they should be sealed with extra insulation.

Watch for the possibility of the outside air intake becoming iced over, or otherwise clogged or restricted. This can be detected by the almost immediate smothering effect of closing the door when burning kindling or the draft control becomes ineffective on flame adjustment (door closed). Keep the air duct clear of obstacles and ensure that rodent/bird guards are in place. Smoke detectors should not be affected if the stove is installed and operated properly.

PIPE SHIELD INSTALLATIONS

When installing optional pipe shields for closer clearances, use a spacer at each end of the shield assembly, and at each joint where the shields overlap. Maintain a 1" (25mm) clearance from the stove top, and a 3" (75mm) clearance from the Security finish support. Note: The Security model 2100 XSF finish support is required for this installation. If more than one pipe shield is required overlap the shields by 1" (25mm) (see Figure 5).

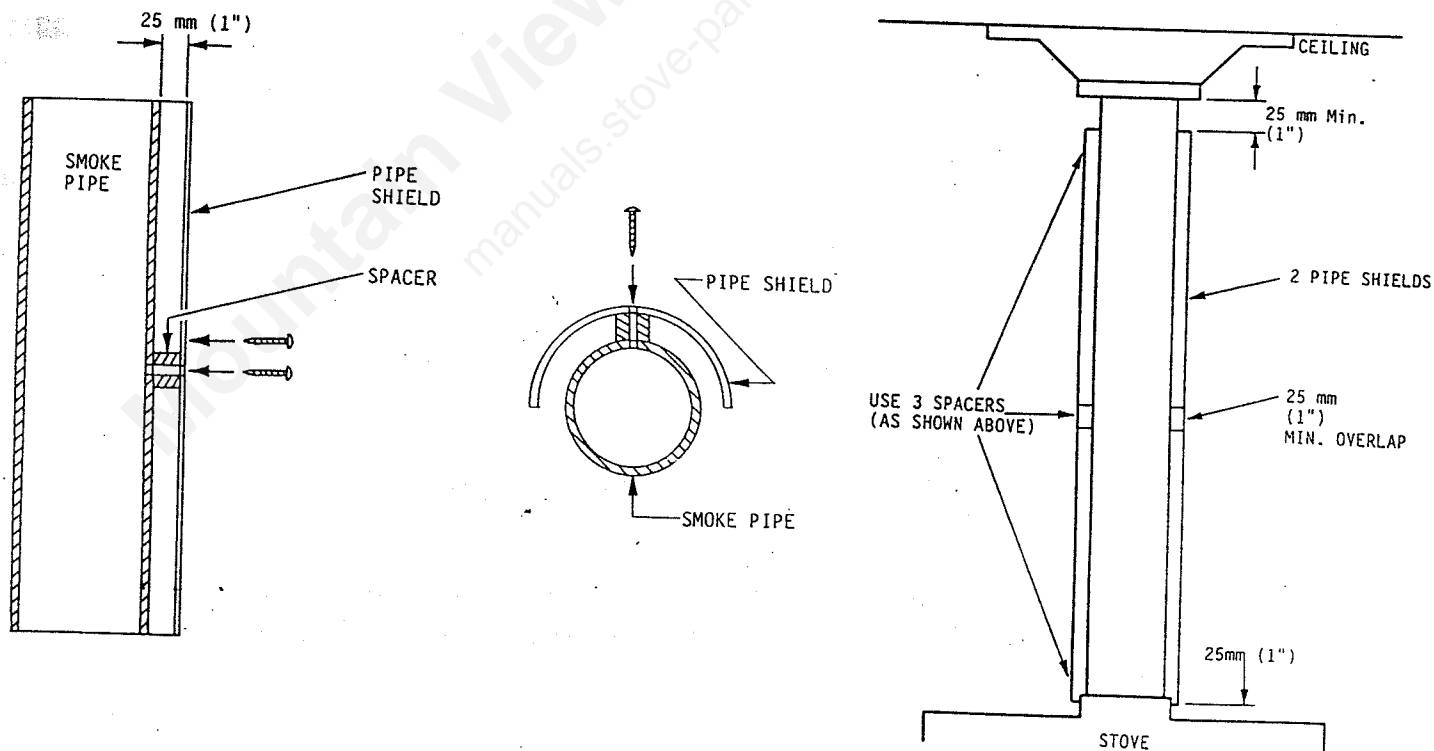

Figure 5

OPERATION

SAFETY INFORMATION

1. Your Osburn stove is designed to burn cordwood fuel only. Fuel for stove must not be stored closer than the required clearances to combustibles and not in the space required for charging and ash removal. Do not burn coal, charcoal or trash in the unit. Highly flammable items such as trash may ignite creosote in the chimney, resulting in a chimney fire.
2. Even though your Osburn has been specifically designed and tested to prevent smoke spillage, always open the door slowly, this will minimize the likelihood of smoke spillage or a back draft of flame or smoke into the room. Ensure that the baffle is pushed tightly against the rear of the stove.
3. Never use gasoline type lantern fuel, kerosene, solvents, charcoal lighter fluid, or inflammable liquids to start or "freshen" a fire in the stove. Keep all such liquids well away from the stove while it is in use.
4. Do not elevate the fire by means of grates.
5. All stove surfaces become very hot during operation. Care is needed, especially with children, to avoid contacting these surfaces.
6. **CAUTION: DO NOT OVERFIRE THIS HEATER.** Do not burn the fuel in the stove at a rate higher than that which will cause the ember bed level to exceed 1/2 the door opening height. If burning hot fires regularly, purchase a stove top thermometer, and do not exceed 450°C (850°F) as measured on the cook top. If the door handle of the stove becomes excessively hot to the touch, consider this to be an indication of overfiring. Overfiring can result in a safety hazard and permanently damage to the stove and chimney, this damage will not be covered by the warranty.
7. Regular chimney maintenance, as well as good burning practices, are required to prevent chimney fires. Establish a routine for firing the stove. Check daily for creosote build-up. (See instructions under chimney cleaning in the maintenance section.) Contact your local, municipal, state, or provincial fire authority for information on how to handle a chimney fire before there is any chance that it may happen.
8. In the event of a stove or chimney component failure, replace only with equipment that is equivalent to the original, available from your Osburn dealer.
9. Ashes should be disposed of with care. (See instructions on ash removal.) Clean the stove frequently so that soot, ash and creosote do not accumulate.
10. Although the ceramic glass is extremely durable under any normal use, a few precautions are required. Do not attempt to push logs further into the fire by using the door, as the glass may break if it is heavily contacted or abused by any solid object.

11. Never operate the stove with the door open, or cracked slightly open, except briefly during the lighting operation, and during refuelling. Leaving the door open continuously could seriously overheat the chimney and adjacent combustibles. Do not operate the stove if there is an abnormal air leakage into the stove, such as through deteriorated gaskets or cracked or broken glass. Do not operate the stove without a door gasket. Leakage can result in overheating, or in very airtight homes, could possibly cause smoking into the room. Smoke contains carbon monoxide which, in sufficient quantities, is poisonous and is a health hazard.
12. If installed, operated and maintained properly, your Osburn stove will give you years of trouble free and safe service.

NOTES ABOUT FIRST FIRES

Before firing, remove the protective plastic covering on the decorative strips and ensure that the room is well ventilated. Burning a large, hot fire the first time is **NOT** recommended, since the heat will burn the uncured paint and give off smoke and odour.

Curing the paint is recommended to preserve the best quality finish. Heating the stove up too intensely on the first fire will dull and lighten the colour on overheated areas, and cause smoke and odour to emit into the room. To cure the paint, the first two fires should be burned for only about twenty minutes. Allow the stove to get only warm but not hot (i.e. 250 degrees F. measured by a stove top thermometer), and allow the stove to cool down. Light a third fire and burn it for about forty minutes to 450 degrees Fahrenheit or less. Once again cool the stove to room temperature, then operate it according to the following instructions. This extra care will result in a more durable, and uniform finish.

LIGHTING A FIRE

1. Place enough crumpled balls of newspaper or paper into the stove to cover the bottom of the firebox.
2. Place small dry kindling on the crumpled paper.
3. Place larger dry kindling on top of the small kindling.
4. Open the draft controls (located on the front of the stove) wide by moving the handle to the right and pulling out. This draft control handle is a dual function control. Moving the control handle from the left toward the right will increase the amount of air flowing down the front across the glass door. Pulling the draft control handle out toward the front will increase the air flowing into the top rear of the firebox - use this front to back action to maximize the secondary combustion once the stove is at operating temperature.
5. Light a fire at the bottom of the crumpled paper and close the door. If the fire tends to go out, momentarily hold the door slightly ajar to fan the fire. As soon as the fire catches hold, close the door.
6. Ideally the large kindling should be burned until a thick bed of red embers is obtained. At that point, add cordwood fuel and continue to operate the front draft controls wide open until the fire is well established. Once the firebox is hot, the draft controls can be partially closed by moving the draft control handle to the left and pushing in to adjust the intensity of the fire.

Use the following table to adjust the draft control to the desired burn rate:

BURN RATE	FRONT DRAFT SETTING	REAR DRAFT SETTING
Low and Medium Low	Move control against the left side	Push control in all the way
Medium	Move control toward right by 1/8"	Pull control out by approx. 1/8"
Medium High	Move control toward right by 3/8"	Pull control out by approx. 1/4 to 1/2"
High	Move control against the right side	Pull control out all the way

Closing the draft control down too soon will hurt combustion efficiency, and result in creosote build-up in the chimney (which could lead to a chimney fire some time in the future).

NOTE: For safety reasons, never leave the unit unattended with the door open or ajar. An open door, and especially a door partially open or cracked if left for longer than required for good ignition can potentially result in unsafe chimney temperatures, and in hot embers or ignited fuel falling out of the unit. Prolonged door open operation is not needed provided the unit has been properly installed and if dry kindling is used to start the fire.

MAINTAINING THE FIRE

Your Osburn stove will work the best if a thick bed of hot embers is maintained in the bottom of the firebox, and a minimum of two large pieces of seasoned fuel are added. Combustion efficiency is largely related to establishing a hot ember bed, and hot firebox temperatures. The quicker the stove and fuel get up to operating temperature, the better. A small intense fire is preferred to a large smouldering fire, both to improve combustion efficiency and to reduce the amount of creosote emitted. The best performance will be obtained by adding relatively small amounts of fuel to a well established ember bed, and then operating with the air inlet control open long enough to obtain a hot fire. Cordwood should be placed with air spaces in between. Use your poker to make an air channel in the embers below the wood, this will allow air to flow under the wood, and cause a more efficient burn. Overnight burns can be accomplished by first operating the stove on a full load with the air inlet controls wide open.

Once the fire is well established, and the moisture has been driven out of the wood, shut the air control to a low setting. The unit should then burn cleanly without smouldering. If the fire smoulders without flame, re-establish a hotter fire before shutting the air control to the low setting. A blue flame burning up in the top of the fire chamber is a good indication of a clean efficiently burning fire.

Refuelling technique is important for good performance. The best efficiency and performance from your stove can be obtained by adding partial loads of fuel and allowing that partial load to get up to operating temperature before adding additional fuel. Adding a large amount of fuel at one time will result in a longer time to get the fuel up to its ignition temperature, resulting in a longer time to reach optimal performance. When refuelling, hold the door partially open (1" or less) long enough (less than 5 minutes) to ensure good ignition of the fuel, so that the fuel has well established flames. When refuelling, care is required to ensure that fuel or embers do not fall out of the door. The unit will burn about 2.0 to 2.5 lb/hour at its minimum setting and so 20 to 25 lbs. of wood are required for an overnight burn.

MAINTENANCE

CARE & CLEANING

Do not attempt to clean the stove, glass or door when the unit is hot. Do not use an abrasive glass cleaner which will scratch the glass. Use only a clean damp cloth on the door, since cleaner may remove the plating or paint.

Under normal operation the glass is designed to stay clean. Glass cleaning may be required when burning damp wood and/or when burning slow fires, however, generally speaking, if the glass is not staying clean then the unit is being underfired. Dirty glass may be self cleaned by burning a hot fire. (i.e. dry wood and opened draft controls) for a couple of hours. **NOTE:** Only hand clean the glass when the fire is out and the stove is cold. A light film can usually be cleaned with paper towel and water. If heavy cleaning is required, the use of a non-abrasive cleaner such as ammonia or commercial glass cleaner for woodstoves is recommended, and should be rinsed off with water for best results. Good burning techniques will result in clean glass.

GLASS REPLACEMENT

NOTE: When the fire is out and the stove is cold, replace only with 9" x 13" (225mm x 325mm) x 5mm Ceramic glass using the original gaskets, retainers and screws. Do not substitute materials. Replacement parts are available from the manufacturer or your local Osburn dealer.

Note where all parts are installed for replacement purposes.

1. Remove the door from the stove by lifting up and off. If hinges are stiff, swing the door from side to side while pulling up.
2. Place the door face down on a flat clean unabrasive surface and remove the two glass retainers by undoing the screws. Use care to avoid scratching the surface of the door.
3. Remove the glass frame and 1/2" (12.5mm) round gasket as a complete unit. Do not remove the gasket from it's frame unless you intend to replace this gasket, in which case high temperature glue is required.
4. Remove the glass.
5. Leave the other gasket around the glass inset in the door and place the new piece of glass on top of it.
6. Install the glass frame assembly on top of the glass with the gasket rope against the glass
7. Replace the frame retainer and screws, being careful not to break the screws, as they will be weaker than usual due to the heat.
8. Turn the door face upwards and push the gasket rope gently back into the frame so that it is evenly distributed around the frame.
9. Replace the door onto the stove.

ASH REMOVAL USING ASH DRAWER

CAUTION: Ashes can start fires, even after several days of inactivity. Never dispose of ashes in a combustible container. Remove ashes only when stove and ashes are cold.

Whenever the ashes get 3 to 4 inches deep in the firebox, they should be emptied into the ash drawer, using the following instructions:

1. Make sure the fire is out, and the stove is cold.
2. Lift the ash plate at the left rear of the firebox by hooking the poker through the loop on the plate and lifting up.
3. Push the ashes through the hole and leave some ashes to cover the ash plate once it is replaced.
4. Clear the ashes from the area where the ash plate normally sits so that the plate will properly seat against the stove bottom; tap it down with your poker to ensure proper seating.
5. Cover the ash plate with the remaining ashes and continue operation of your stove as usual.
6. The ash drawer itself should be emptied when full. It is located on the left side of the pedestal and can be removed by pulling it out toward the left. The ashes should be placed in a metal container with a tightly fitting lid. The closed container of ashes should be placed on a non-combustible floor or on the ground, well away from all combustible materials, pending final disposal. See also number 6 of your Operating Safety Instructions.

Leave an ash bed of approximately 1" (25mm) deep on the firebox bottom to help maintain a hot ember bed. If the ashes are disposed of by burial in soil or otherwise locally dispersed, they should be retained in the closed container until all cinders have thoroughly cooled. Do not place other waste materials in the metal ash container.

CAUTION: If bright embers are burning at the back left corner of the firebox during the operation of a low or medium low fire, air may be leaking past the ash plate. If this is happening, a possible fire hazard exists. The stove should be shut down and allowed to cool and a proper sealing of the ash plate to the stove bottom should be made.

CHIMNEY CLEANING

The chimney and the chimney connector pipe must be maintained in good condition and be kept clean in order to be safe. This means that the chimney should be checked regularly for creosote build-up. Inspection and cleaning of the chimney is facilitated by a removable baffle. When wood is burned slowly, it produces tar and other organic vapours, which combine with expelled moisture to form creosote. The creosote vapours condense in the relatively cool chimney flue of a slow-burning fire. As a result, creosote residue accumulates on the flue lining. When ignited, this creosote makes an extremely hot fire.

Your Osburn stove has been designed to reduce the amount of creosote produced. Even so, the chimney connector pipe and chimney should be inspected at least once every two months during the heating season to determine if a creosote build-up has occurred. If creosote has accumulated, it should be removed to reduce the risk of chimney fire. Call a professional chimney sweep, or go to your local Osburn dealer and obtain a do it yourself chimney brush, and have the chimney cleaned.

BAFFLE REMOVAL

To remove the baffle, push up on the right side of the baffle and remove the right top brick. Then raise the whole baffle, move the baffle toward the front and lower the right side down toward the door opening, and out the door. ALWAYS operate the unit with the baffle in place with the fiberfrax insulation over it. Installation is the reverse of the removal.

Fire prevention planning should include contacting your local, municipal, provincial, or state authority for information on how to handle a chimney fire in the home. Establish a plan on what to do in case of a fire, and on how to get out alive. The minimum fire protection in any home should be a smoke detector and a fire extinguisher. In the event of a chimney fire, close the draft control, and call your fire department.

WOOD FUEL INFORMATION

Seasoned dense wood is recommended. Wood should be air dried in a ventilated under cover area for six months to a year or more. This reduces the moisture content of the wood, resulting in better stove performance. An example of the energy values of some common wood fuels is given in the table. Dry seasoned wood can be distinguished from green wood because it has checks or cracks in the ends. Wet or green wood will tend to cause the fire to smoulder, producing large amounts of creosote. It will also prove difficult to keep burning properly and the fire will tend to go out. Green wood produces very little heat, and sometimes is the cause of customers thinking that the stove does not work. Decayed wood or low density wood has very little energy content or heating value, and will not burn satisfactorily for long periods of time. In New Zealand Clean Air Zones, use of damp, wet (greater than 25% moisture content), or green wood is not permitted.

For recommended and maximum wood sizes, refer to the specifications. If you must burn wet wood, use only small amounts mixed with dry wood. Never burn salt wood, beachwood, chemical treated wood, or wood which was in salt water since the deposits left will deteriorate the firebox. Damage caused by chemical or salt is not covered under warranty.

WOOD SPECIES Hardwoods	(20% MOISTURE) MILLION BTU/CORD	WOOD SPECIES Softwoods	(20% MOISTURE) MILLION BTU/CORD
Birch	23.6	Fir Douglas	20.6
Oak, White	28.3	Hemlock	17.1
Alder	17.6	Jack Pine	18.4
Apple	33.0	Spruce	16.8
Maple	24.4	Cottonwood	16.2

WOOD MOISTURE TEST

Add one large piece of wood to the top of an established fire. If it starts to burn on three sides within one minutes, it is dry and seasoned and right for burning. If it turns black and starts to burn in three minutes, it is damp. If it turns black and does not start burning until after five minutes, it is green and wet. If it hisses at any time the wood is soaked and will not burn until excess moisture is boiled away.

TROUBLE SHOOTING

<u>Problem</u>	<u>Possible cause</u>	<u>Solution</u>
Smoke in the room	Downdraft Chimney blocked Chimney damper shut Baffle out of place Upgrade chimney	Clean chimney Open or remove damper Locate baffle in position Paint is curing Refer to instructions
Wood burns poorly, or is slow to start	Low draw Wet or decayed wood	Upgrade chimney Use proper fuel or no heat
Blocked intake air		Check intake air supply by removing panel on pedestal and opening a window
Dirty glass	Stove is being underfired	Refer to instructions
Wood burns too fast	Too much draft in chimney Air leakage	Install manual damper in connector pipe. Check air control to see if flame is affected by low and high settings.

SPECIFICATIONS

MODEL	Osburn 1050
TEST STANDARDS	<ol style="list-style-type: none">1. ULC S627 (CSA B366.2) residential2. UL 1482 residential and mobile home (U.S.A. only)3. Oregon Department of Environmental Quality4. U.S. Environmental Protection Agency. Passed July 1990 emissions standards
HEAT OUTPUT RANGE	10600-42900 BTU/Hr.(at 63% default efficiency) BTU/HR output will vary with cord wood usage depending on the type and condition of cord wood used.
SHIPPING WEIGHT	285lbs (130 Kg)
COOK TOP HEIGHT	28" (710mm)
COOK TOP WIDTH	24" (610mm)
DEPTH	22" (560mm)
MINIMUM NON-COMBUSTIBLE HEARTH SIZE	36" wide x 43" deep (915mm wide x 1095mm deep)
FIREBOX SIZE	16 3/4" wide x 12" deep (426mm wide x 305mm deep)
DOOR OPENING SIZE	15" wide x 8 3/4" high (381mm wide x 222mm high)
RECOMMENDED LOG SIZE	14 1/2" x 6" Dia. (368mm x 150mm Dia.)
FLUE OUTLET	6" Dia. (150mm) diameter
OPTIONS	<ul style="list-style-type: none">- FAN (In Canada Only)- OUTSIDE COMBUSTION AIR- ETCHED GLASS