

QUADRA-FIRE

Installation, Operation, and Maintenance Instructions
Models: Quadra Fire-2000 & Quadra Fire-3000

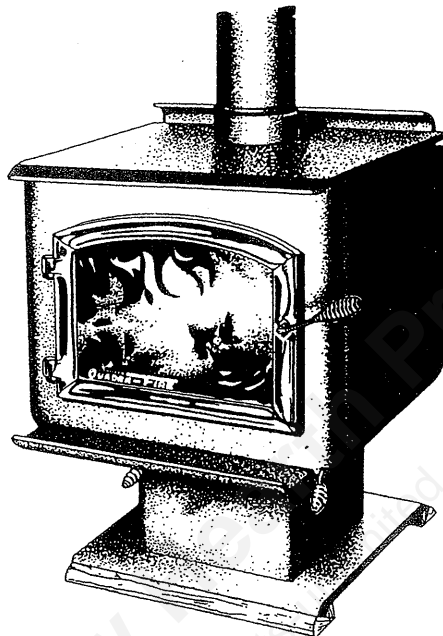

CONGRATULATIONS-You are now the proud owner of one of the finest stoves in the world for you home-the **QUADRA-FIRE**.

Now, before installing your stove and building your first fire -

PLEASE READ ALL OF THE OWNERS MANUAL AND SAFETY NOTES.

IMPORTANT SAFETY NOTES:

1. When installing your stove, particular attention should be paid to fire protection. If this unit is not properly installed, a house fire may result. For your safety, follow the installation instructions and contact local building or fire officials about restrictions and installation inspection requirements in your area.
2. Never use gasoline or similar liquids to start a fire in this unit. Keep all such liquids well away from stove.
3. During operation, if any part of the stove starts to glow, the stove is in an overfired condition. Close the primary and secondary air controls completely until the glowing has stopped.
4. Cool ashes should be disposed of carefully - using a metal container.
5. Do not burn wet or green wood. Store in dry location.
6. Do not burn garbage.
7. Do not permit creosote or soot to accumulate excessively in the chimney or inside the firebox.
8. Check your chimney system thoroughly when installing into an existing metal or masonry chimney. Seek professional advice if in doubt about its condition.
9. Do not use single wall pipe for exterior chimney applications.
10. Do not connect this unit to a chimney flue already serving another appliance.
11. Comply with all minimum clearances to combustibles as shown in this manual.



401 N. Wynne

Colville, Washington 99114

TABLE OF CONTENTS

I.	Installation Materials Needed	3
II.	Installation	3
	Clearances to Combustibles	3
	Floor Protector	3
	Venting System	4
	Chimney Connector	4
	Connection to a Masonry Chimney	4, 5
	1. Chimney	5
	2. Thimble	6
	A. Brick chimney thimble assembly	7
	B. 6 inch solid pack chimney with metal supports	8
	Connection to a Masonry Fireplace	8
	Connection to a Metal Prefabricated Chimney	9, 10
	Mobile Home Installation	11, 12
III.	Operating Instructions	13
	Primary and Secondary Air Systems	13
	Operating Tips	13
	Building A Fire	13
	Care & Cleaning of Glass & Plated Surface	14
	Ash Removal	14
	Firebrick	14
	Wood Selection & Storage	14
IV.	Maintenance Instructions	15
	Creosote	15
	1. Formation and need for removal	15
	2. Inspection and removal	15
V.	Warranty	15
	Warranty Card	15, 16

INSTALLATION MATERIALS NEEDED FOR YOUR SAFETY

CHIMNEY CONNECTOR: (also known as flue pipe or stove pipe) The chimney connector joins the stove to the chimney. It should be 6 inch diameter 24 MSG black or blued steel 24 gauge minimum.

THIMBLE: A manufactured or site-constructed device installed in combustible walls through which the chimney connector passes to the chimney. *It is intended to keep walls from igniting.*

CHIMNEY: APPROVED MASONRY (see specifications on page 3 with at least 5/8" fire clay lining joined with refractory cement or other listed system suitable for use with wood stoves
or

PREFABRICATED 6 inch listed high temperature* residential type and building heating appliance chimney. Components required by manufacturers for installation such as the chimney support base, firestop (as appropriate), attic insulation shield, insulated tee, etc., are necessary to assure a safe chimney installation. Use only components manufactured for the chimney.

CLEARANCE TO COMBUSTIBLES

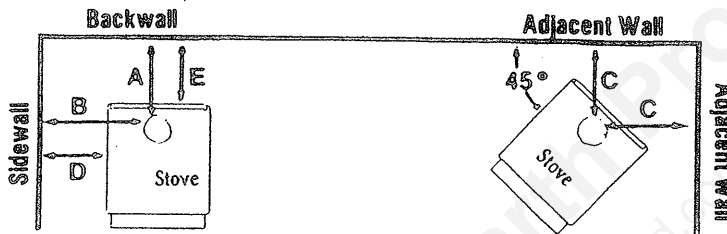

Minimum Clearances to Combustible Materials (in inches)

Installation	Clearance	Chimney & Connector	Dimension				
			A	B	C	D	E
Residential	Standard	Note: 1	14	21	18	13	11
Residential	Reduced	Note: 2	6	21	18	13	3
Mobile Home	Standard	Note: 3	6	21	18	13	3
Alcove	Standard	Note: 2 & 3	6	21	N/A	13	3

AVOID FIRE: Maintain the designated clearance distance to combustibles. Insulation must *not* touch the chimney. There must be the designated air space clearance around the chimney. This air space around a chimney is necessary to allow natural heat removal from the area. Insulation in this space will cause a heat buildup which may ignite wood framing.

Note 1: 6 inch diameter single wall, minimum 24 MSG black or blued steel connector pipe with listed factory-built chimney suitable for use with solid fuels or a masonry chimney.

Note 2: 6 inch diameter double wall air insulated connector pipe with listed factory-built Class "A" chimney or a masonry chimney. (Mobile Home must be equipped with a rain cap and spark arrestor).

Note 3: Alcove spec's: Maximum depth of Alcove shall be no more than 48", and a minimum of 72" high. Minimum distance from stove to header/arch is 32". Minimum distance from stove is 13" to sidewall, 42" ceiling.

Note: Unit has not been tested with a horizontal connector. Refer to local building codes.

When locating your stove, consider safety, convenience, traffic flow, and the fact that the stove will need a chimney and chimney connector.

FLOOR PROTECTOR:

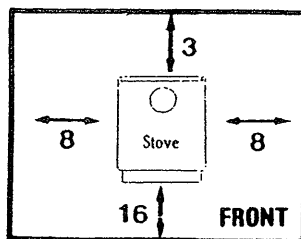

Floor protector must be 3/8" min. thickness non-combustible material or equivalent, extending beneath heater and to the front/sides/rear as indicated.

*Chimney tested to 2100 °F.

VENTING SYSTEM

The venting system consists of a chimney connector and a chimney. These get extremely hot during use. Temperatures inside the chimney may exceed 2000° in the event of a creosote fire. To protect against the possibility of a house fire, the chimney connector and chimney must be properly installed and maintained. A thimble *must* be used when a connection is made through a combustible wall to a chimney. A chimney support package *must* be used when a connection is made through the ceiling to a prefabricated chimney. These accessories are absolutely necessary to provide safe clearances to combustible wall and ceiling material.

This stove may be connected to a lined masonry chimney or a listed high temperature prefabricated residential type building heating appliance chimney. Do not connect it to a chimney serving another appliance. To do so will affect the safe operation of both appliances.

CHIMNEY CONNECTOR

The chimney connector must be 6 inch diameter 24 gauge minimum (type) steel. Do not use aluminum or galvanized steel. They cannot properly withstand the extreme temperatures of a wood fire. Do not use chimney connector pipe as a chimney. You must connect your stove to a chimney comparable to those illustrated in this manual.

Chimney connector sections must be attached to the stove and to each other with the crimped end toward the stove (FIGURE 1). This allows creosote to run into the stove and not onto the outside of the pipe. All joints should be secured with three sheet metal screws. Otherwise, in the event of a creosote fire, the connector may vibrate apart.

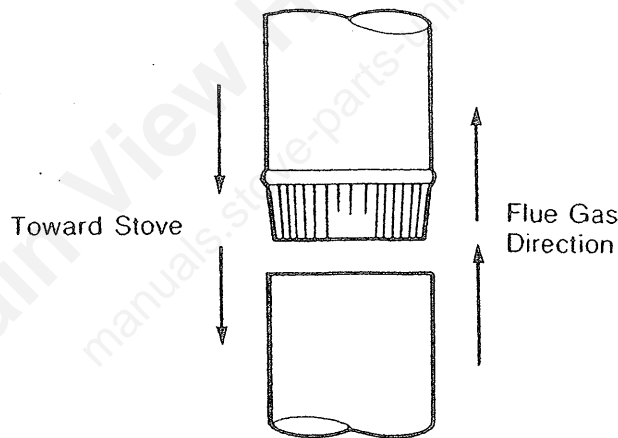

Figure 1

For proper operation the chimney connector should be as short as possible. Horizontal lengths of chimney connector should have an upward slope from the stove of 1/4 inch per foot.

Maintain 14 inches clearances between the chimney connector and the wall and ceiling unless a wall protection system is installed.

CONNECTION TO A MASONRY CHIMNEY

1. Chimney-Should the stove be connected to masonry chimney, the chimney should be examined for cracks, loose mortar, other signs of deterioration and blockage. The stove should not be installed until it is determined that the chimney is safe for use. Since an oversized flue contributes to the accumulation of creosote, the size of the flue should be checked to determine that it is not too large for the stove. For this stove, the flue should be no larger than 30 sq. inches. The chimney should also be checked to assure it meets the minimum standards of the National Fire Protection Association (NFPA) Standard 211. Following is a list of the more critical minimum requirements for a properly constructed chimney.

The masonry wall of the chimney, if brick or modular block, must be a minimum of 4 inches nominal thickness. A mortar or rubble stove wall must be at least 12 inches thick.

The chimney must have a fire clay flue liner (or equivalent) with a minimum thickness of 5/8 inch and must be installed with refractory mortar. There must be at least 1/2-inch air space between the flue liner and the chimney wall (FIGURE 2). An equivalent liner must be a listed chimney liner system or other approved material.

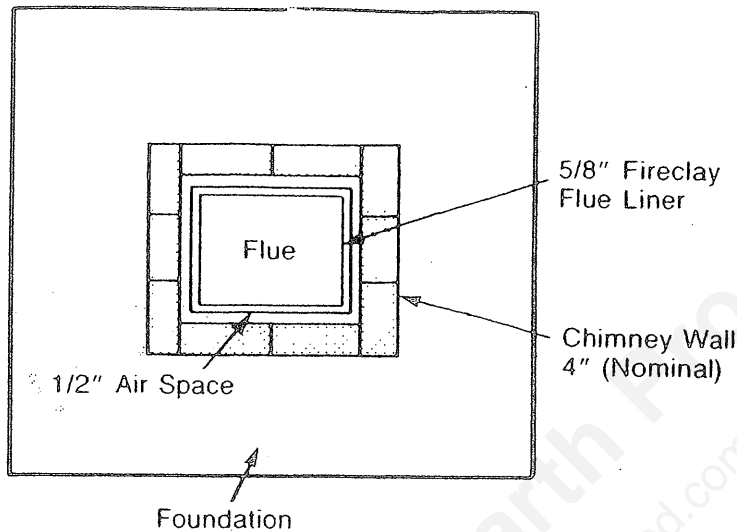

Figure 2

A chimney inside the house must have at least 2 inches of clearance to the combustible structure. A chimney outside the house must have at least one inch clearance to the combustible structure. Fire stops must be installed at the spaces where the chimney passes through floors and/or ceiling (FIGURE 3).

FIRESTOPPING

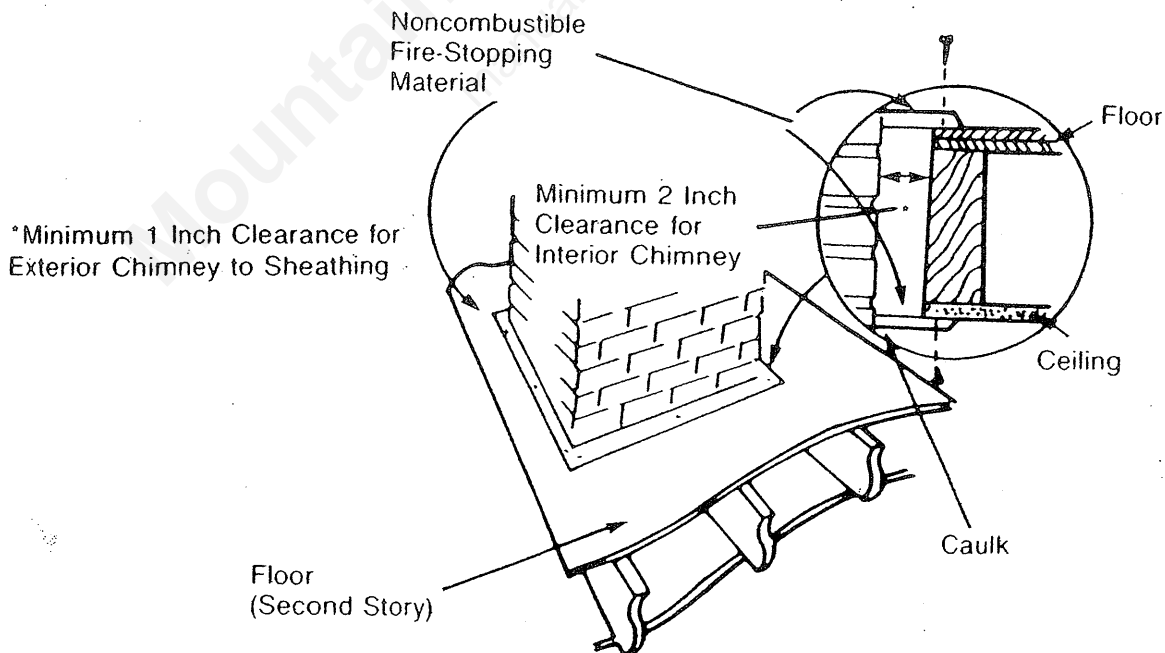

Figure 3

Remember that insulation must not contact the chimney. There must be air space around the chimney. Insulation must be 2 inches or more from the chimney (FIGURE 4).

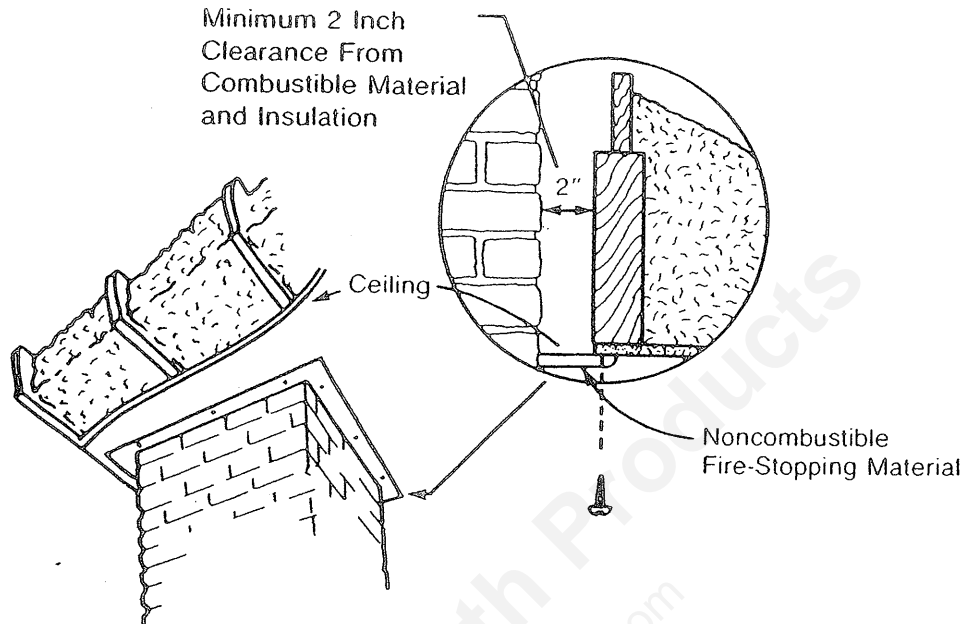

Figure 4

A chimney must be the required height above the roof or other obstruction for safety and for proper draft operation. The requirement is that the chimney must be at least 3 feet higher than the highest point where it passes through the roof and at least 2 feet higher than the highest part of the roof or structure that is within 10 feet of the chimney, measured horizontally (FIGURE 5).

CHIMNEY HEIGHT

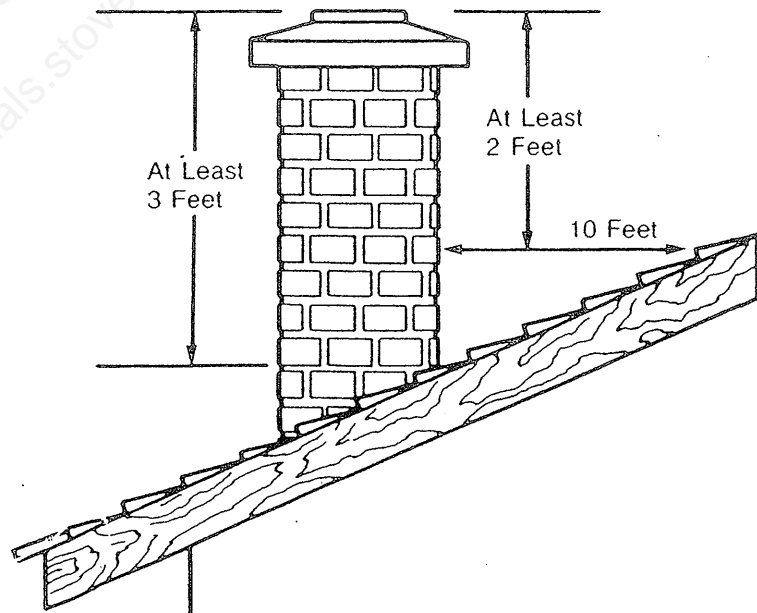

Figure 5

2. Thimble-A thimble must be used when the connection from the stove is made through a combustible wall into a masonry chimney. There are several methods to use for connection through a combustible wall, two of which are illustrated in this manual. Local building authorities may be consulted or NFPA 211 may be used for additional methods of chimney connection.

Also, listed prefabricated metal thimbles can be bought for use with wood stoves. The manufacturer's installation for the thimbles must be strictly followed to assure the safety of the system. Be sure to maintain the designated clearance to combustible materials.

A. Brick chimney thimble assembly-Construction of the brick thimble assembly requires 12 inches of brick around a fire clay liner. Be sure the point of penetration allows a 24 inch clearance from the connector to the ceiling. An opening of 30 inches (for a 6 inch chimney connector) must be cut in the wall to maintain the required 12 inches of brick separation from combustibles. It will be necessary to cut wall studs and install a header and sill frame to maintain proper dimensions and to hold the weight of the brick (FIGURE 6).

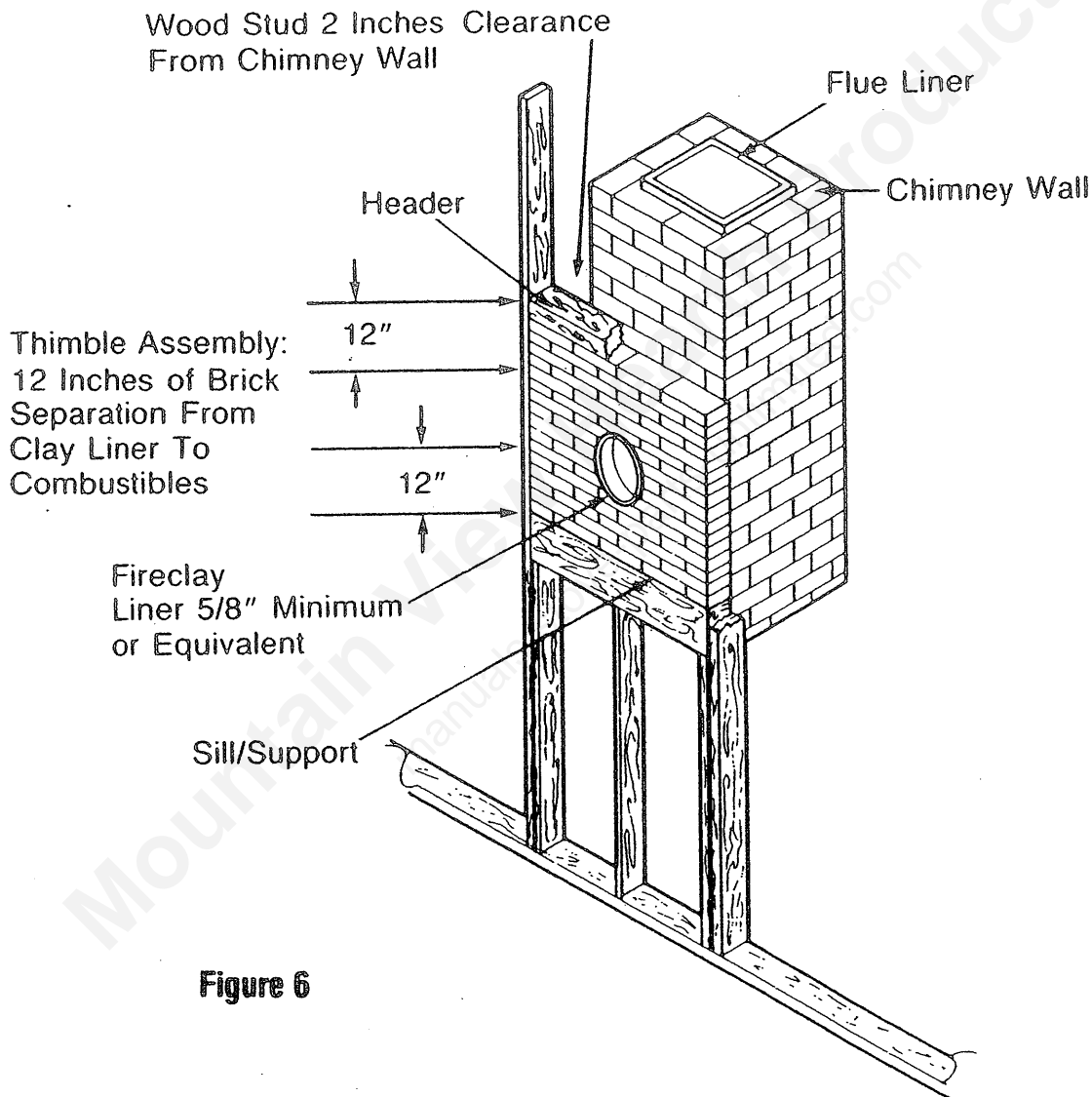
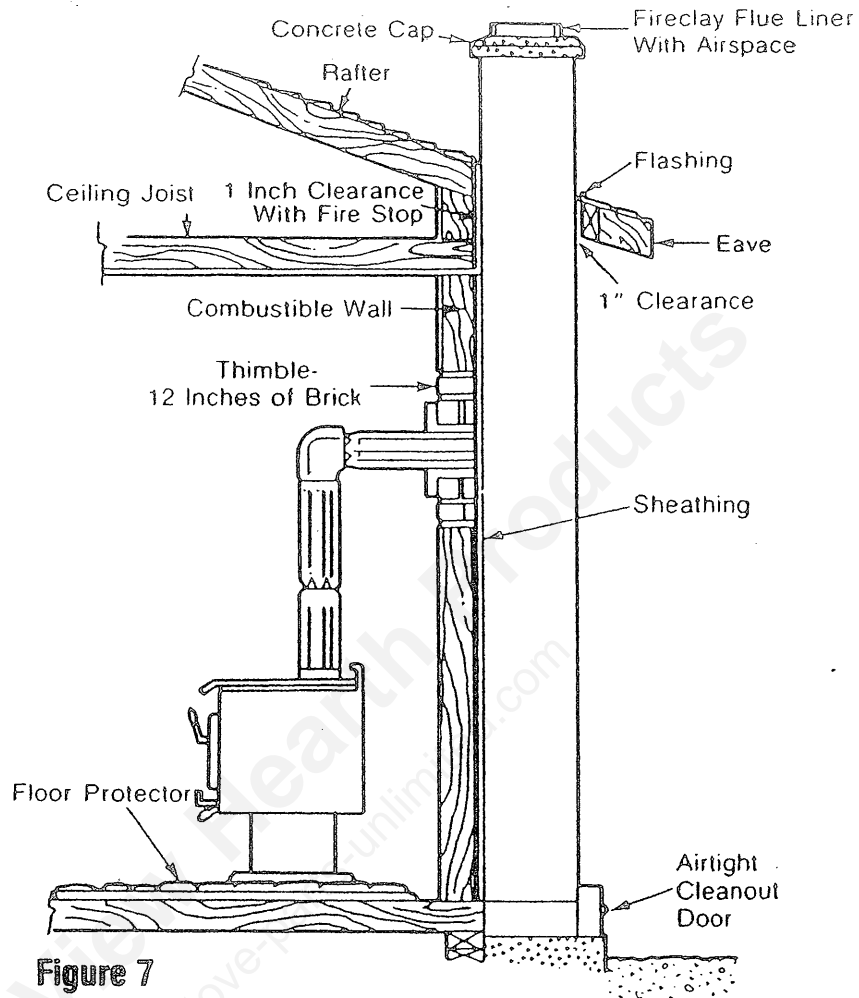

Figure 6

Minimum 3 1/2-inch (4-inch nominal) thick solid bricks are to be used. The fire clay liner (ASTM C35 or equivalent), minimum 5/8-inch wall thickness, must not penetrate into the chimney beyond the inner surface of the chimney flue liner and must be firmly cemented in place. If it is necessary to cut a hole in the chimney liner, use extreme care to keep it from shattering. Refractory mortar must be used at the junction to the chimney liner (FIGURE 7). After the assembly is complete, insert the chimney connector in the fire clay liner. Do not push it beyond the inside edge of the chimney liner because this will affect the draw of the chimney.



B. 6 inch solid pack chimney with metal supports as a thimble-For the method of installation to a masonry chimney shown in FIGURES 8 and 9, it will be necessary to purchase a 6 inch inside diameter 12-inch long section of prefabricated listed solid pack chimney to use a thimble. Purchase a wall spacer, trim collar and wall band that are manufactured to fit the chimney section you purchase.

The safety features of this system are: the 2-inch air space between the chimney section and combustible wall, and the 1-inch air space around the chimney connector as it passes through the chimney section to the chimney.

The location of the opening through the wall to the chimney must leave a minimum 24 inch vertical clearance between the connector pipe and the ceiling to prevent the ceiling from catching fire.

Cut out a 14 1/2 inch diameter opening in the wall. It may be necessary to cut wall studs and install a header and sill frame to maintain the wall support. The hole in the chimney must have at least a 6 inch diameter fire clay liner or equivalent secured with refractory mortar. If it is necessary to cut a hole in the chimney liner, use extreme care to keep it from shattering.

First, make the frame for the thimble, being sure it is no smaller than 14 1/2 inch diameter, to maintain a 2-inch air space around the chimney section. Attach the wall spacer to the chimney side of the frame. Then insert the frame into the opening, toenailing it to the wall studs. Install the wall band in the framing to secure the chimney section in place. Insert a single section of chimney connector into the chimney through the wall band, being sure it does not protrude into the chimney beyond the edge of the chimney flue lining. Apply high temperature furnace cement to the end of the chimney section and install it over the connector, through the wall band, and through the wall spacer. Tighten the wall band to hold the chimney section firmly in place and against the chimney. Install the trim collar on the outside of the opening. Check to assure there is a 1-inch air space between the connector and the chimney section. Also, during installation, always check to assure that a 2-inch air space is being maintained to the wood framing. Do not fill this space with insulation. Insulation in this air space will cause a heat buildup which may ignite the wood framing.

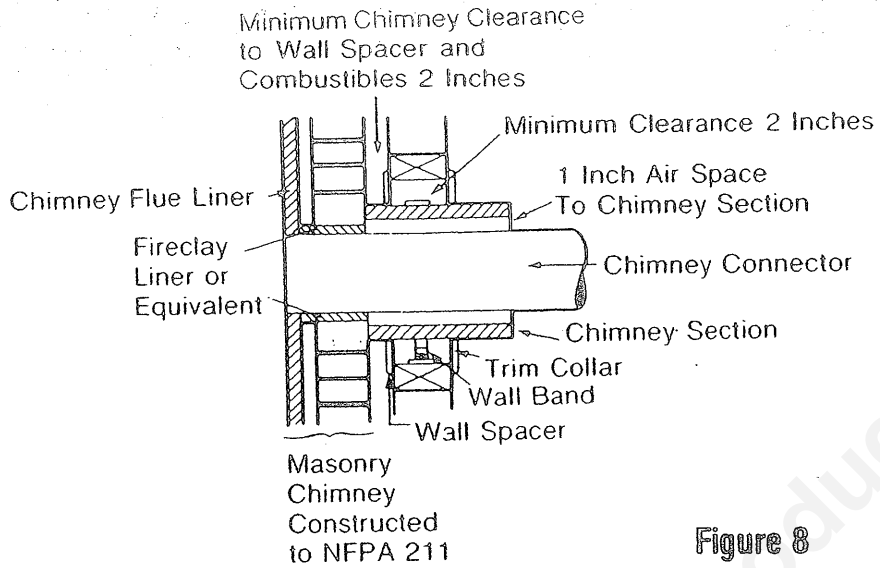

Figure 8

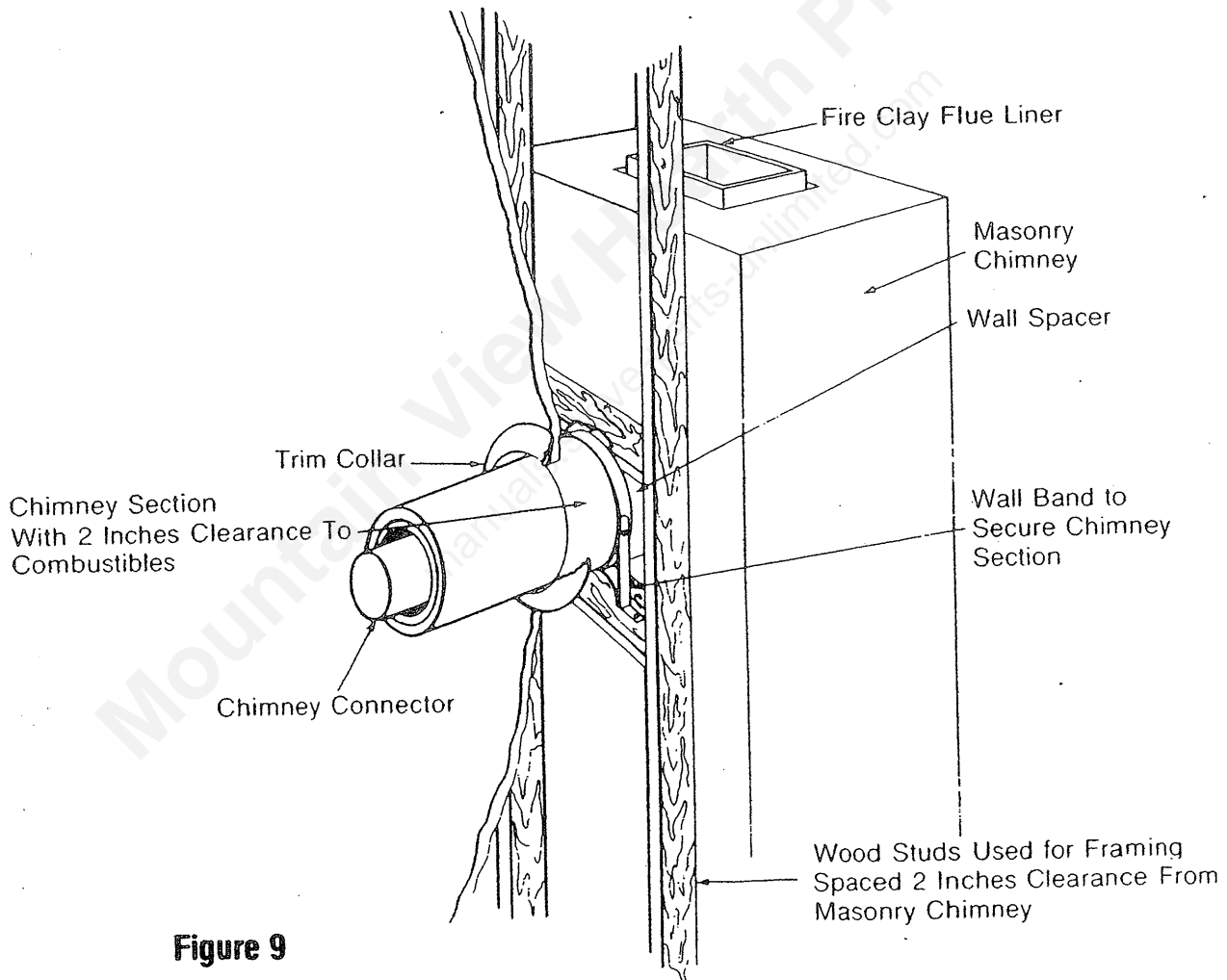

Figure 9

CONNECTION TO A METAL PREFABRICATED CHIMNEY

When a metal prefabricated chimney is used, the manufacturer's installation instructions must be followed precisely. You must also purchase (from the same manufacturer) and install the ceiling support package or wall pass through and "T" section package, firestops (when needed), insulation shield, roof flashing, chimney cap, etc. Maintain the proper clearance to the structure as recommended by the manufacturer. This clearance is usually a minimum of 2 inches, although it may vary by manufacturer or for certain components.

There are basically two methods of metal chimney installation. One method is to install the chimney inside the residence through the ceiling and the roof (FIGURES 10 and 11). The other method is to install an exterior chimney that runs up the outside of the residence (FIGURES 12 and 13). The components illustrated may look exactly like the system you purchase, but they demonstrate the basic components you will need for proper and safe installation.

The chimney must be the required height above the roof or other obstruction for safety and for proper draft operation. The requirement is that the chimney must be at least 3 feet higher than the highest point where it passes through the roof and at least 2 feet higher than the highest part of the roof or structure that is within 10 feet of the chimney, measured horizontally (FIGURE 5).

REMEMBER: Follow the manufacturer's installation instructions and maintain the manufacturer's specified clearance distances.

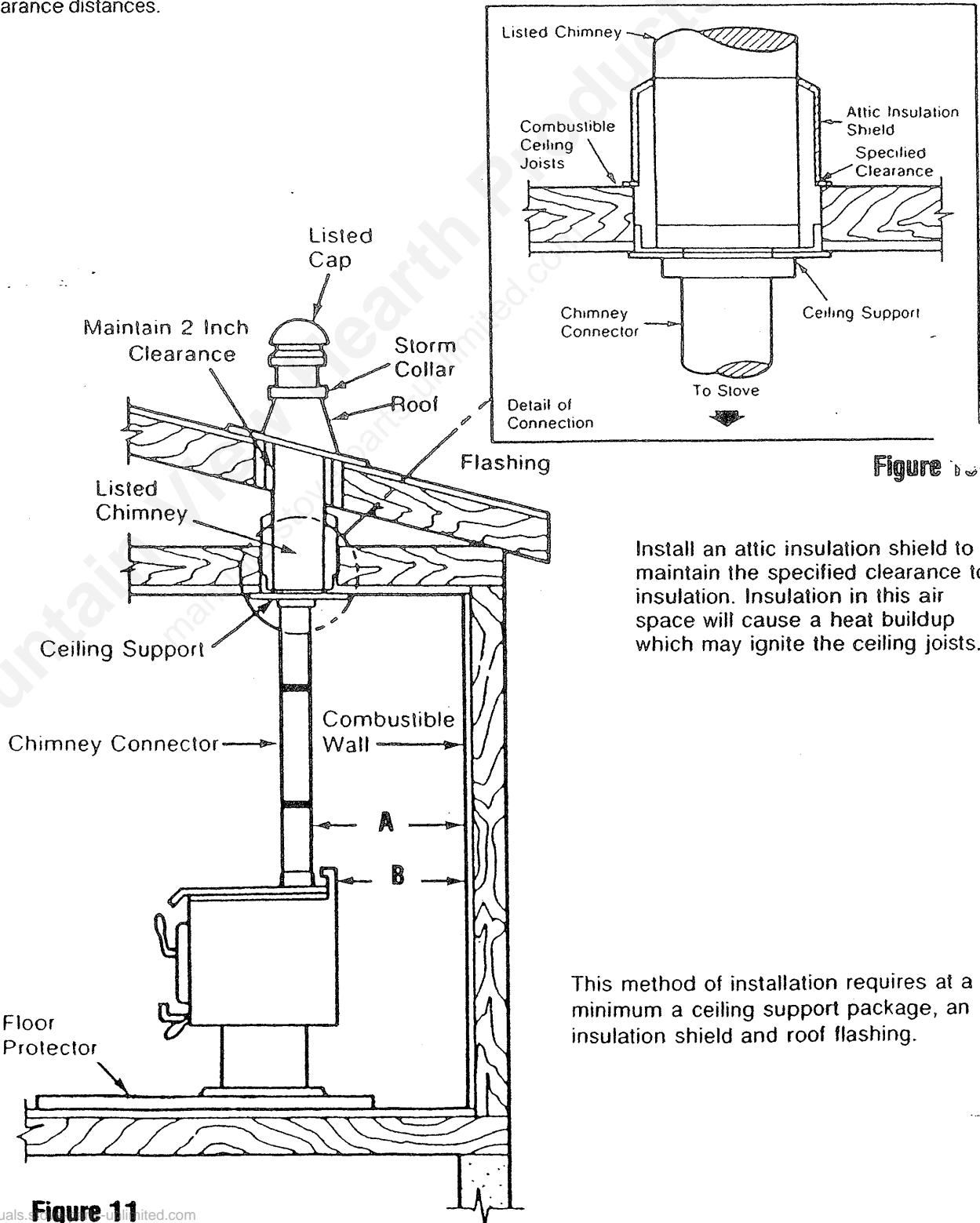

Install an attic insulation shield to maintain the specified clearance to insulation. Insulation in this air space will cause a heat buildup which may ignite the ceiling joists.

This method of installation requires at a minimum a ceiling support package, an insulation shield and roof flashing.

Minimum Clearances to Combustible Materials (in inches)

Installation	Clearance	Chimney & Connector	Dimension	
			A	B
Residential	Standard	Note: 1	14	11
Residential	Reduced	Note: 2	6	3
Mobile Home	Standard	Note: 2	6	3
Alcove	Standard	Note: 2 & 3	6	3

Note 1: 6 inch diameter single wall, minimum 24 MSG black or blued steel connector pipe with listed factory-built chimney suitable for use with solid fuels or a masonry chimney.

Note 2: 6 inch diameter double wall air insulated connector pipe with listed factory-built Class "A" chimney or a masonry chimney. (Mobile Home must be equipped with a rain cap and spark arrestor).

Note 3: Alcove spec's & maximum depth of Alcove shall be no more than 48", and a minimum of 72" high. Minimum distance from stove to header/arch is 32". Minimum distance from stove is 13" to sidewall, 42" to ceiling.

Note: *Unit has not been tested with a horizontal connector. Refer to local building codes.

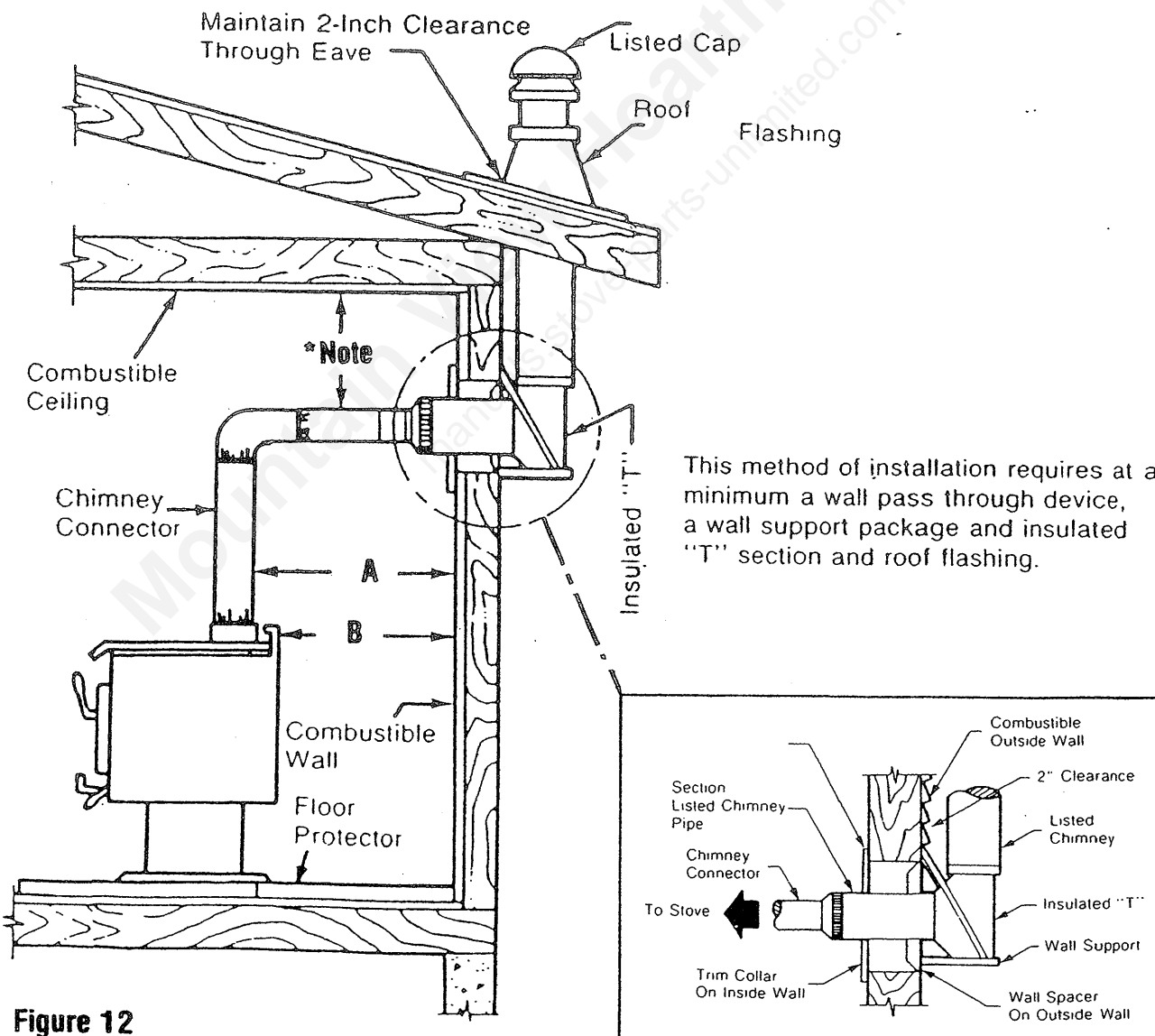

Figure 12

Figure 13

MOBILE HOME INSTALLATION

Must use required outside air kit #60-EG see (FIGURE 14) for installation into mobile home.

1. An outside air inlet must be provided for combustion and be unrestricted while unit is in use.
2. Unit is to be secured to mobile home structure.
3. Do not install unit in a sleeping room.
4. The structure integrity of the mobile home floor, walls, and ceiling/roof must be maintained.
5. Unit is to be grounded with #8 copper grounding wire or equivalent and terminated at each end with N.E.C. approved grounding device.
6. Refer to clearance to combustibles section page 2 for listing to combustibles plus appropriate chimney and connector.

OUTSIDE AIR KIT INSTRUCTIONS:

1. Remove screws from each side of secondary draft door.
2. Install cover (A) using the two screws as illustrated.
3. Rodent screen (B) can be screwed or nailed down to cover hole through floor of hearth.
4. Slide 1 1/4" rope gasket (C) underneath base of stove to seal off room air.

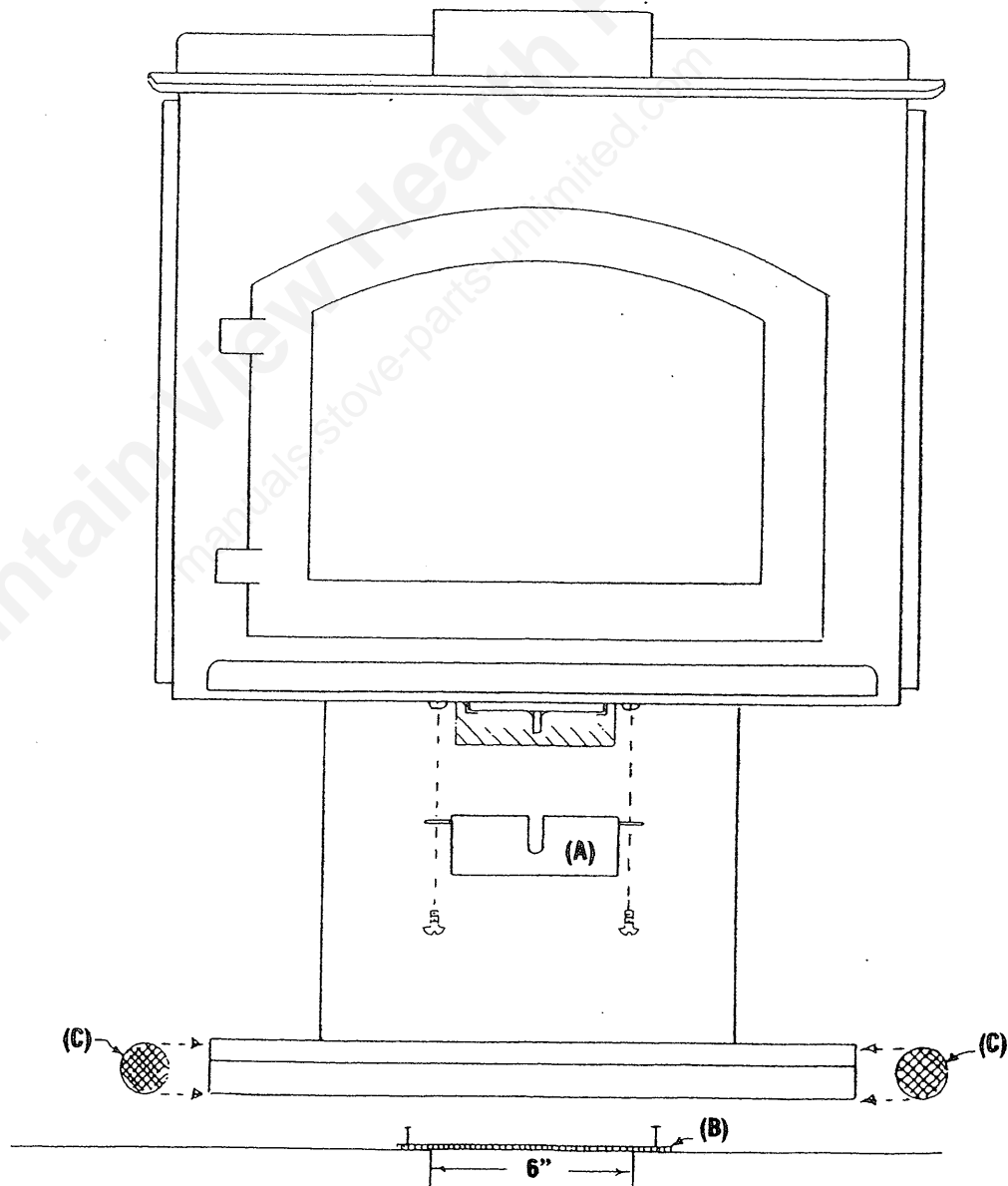

Figure 14

OPERATION OF STOVE

The **Quadra-Fire 2000 & 3000** has met and surpassed the most stringent emissions standards in the nation. Proper operation and maintenance of your appliance is essential to obtain peak efficiency and lowest emissions which result in more heat per pound of wood. Follow the operating procedures listed below for best results.

PRIMARY AIR SYSTEM

The primary combustion air enters in at the lower rear of the firebox through the diffuser plate. This air supply is controlled by the push rod located at the front right side of the stove. For maximum burn rates (more heat) push rod in, for minimum burn rates (less heat) pull rod out.

SECONDARY AIR SYSTEM

The secondary air enters at the upper front of the firebox near the top of the glass door. This pre-heated air supplies the necessary fresh oxygen to mix with the unburned gases, helping to create secondary, tertiary and quaternary combustions. This air is regulated by the push rod beneath the ash catcher. For more secondary air, push rod in, for less secondary air, pull rod out.

OPERATING TIPS

Here are a few tips on operating your **Quadra-Fire** stove to obtain efficiency with lowest emissions.

1. Regardless of desired heat output, when loading stove, burn it hot for a minimum of five minutes before setting draft controls for desired heat output.
2. Regulate burn rate (heat output) by primary draft control. Use only enough secondary air to ignite and maintain secondary combustion. On low to medium burn rates this means that the secondary air needs to be open 1/32" to 1/4".
3. Heat output settings:

B.T.U./hr.	Primary	Secondary
1. Below 10,000	Closed	3/8" open for 10 minutes then close to 1/32" open
2. 10,000-15,000	Closed	3/4" open for 10 minutes then close to 1/16" open
3. 15,000-30,000	1/4" Open	3/4" open for 12 minutes then close to 1/4 open
4. Maximum heat	Full Open	Full Open

4. Burn dry, well-seasoned wood (See Wood Selection and Storage).

BUILDING A FIRE

There are many ways to build a fire. The basic principle is to light easily ignitable tinder or paper, which ignites the fast-burning kindling, which in turn ignites the slow burning firewood. Here is one method that works well:

1. Place several wads of crushed paper on the firebox floor.
2. Lay small dry sticks of kindling on top.
3. Open primary and secondary air controls fully.
4. Make sure that no matches or other combustibles are in the immediate area of the stove. Be sure the room is adequately ventilated and the flue unobstructed.
5. Light the wadded paper in the stove, **Never** light or rekindle stove with kerosene, gasoline, or charcoal lighter fluid; results can be fatal.
6. Keep door ajar about one inch for one to two minutes or until kindling is sufficiently ignited then close the door.
7. Once the kindling is burning quickly, add several full length logs three to four inches in diameter. Be careful not to smother the fire. Stack the pieces of wood carefully - near enough to keep each other hot, but far enough away to allow adequate air flow between them.
8. When ready to reload the stove, add more logs. Large logs burn slowly, holding a fire longer. Small logs burn fast and hot, giving quick heat. Larger logs create less creosote and emissions than smaller logs.
9. Adjust the primary and secondary air controls: the more you close down the controls, the lower and slower the fire will burn. The more open the controls are, more heat will be produced.

As long as there are hot coals, repeating steps eight and nine will maintain a continuous fire throughout the season.

Note: The special high temperature paint that your stove is finished with will cure as your stove heats. You will notice an odor and perhaps see some vapor rise from the stove surface, this is normal. We recommend that you open a window until the odor dissipates and paint is cured.

CARE AND CLEANING OF GLASS

Quadra-Fire stoves are equipped with "Pyroceram II" super heat resistant glass which can only be broken by impact or misuse. Do not slam stove door or impact the glass. When closing door, make sure that logs do not protrude against glass.

Clean glass with a non-abrasive glass cleaner such as Elco Glass Cleaner, available from your Aladdin dealer. Abrasive cleaners may scratch and cause glass to crack.

Inspect glass regularly. If you find a crack or break, immediately put fire out and return door to your dealer for replacement of glass before further use. Do not substitute materials for glass replacement.

CARE AND CLEANING OF PLATED SURFACES

Clean 24K gold plated surfaces with warm soapy water. Nickel plated surfaces can be cleaned with a non-abrasive polish such as Flitz Metal Polish, available from your Aladdin dealer. Polishes with abrasive agents will scratch.

ASH REMOVAL

Remove cold ashes (never hot) from the stove by shoveling them into a metal container with a tight-fitting lid. Always treat ashes as if they contain hot coals and store the container on a non-combustible floor away from combustible material pending final disposal.

FIREBRICK

The firebox of your **Quadra-Fire** Stove is lined with high quality firebrick which has exceptional insulating properties. No need for a grate, simply build a fire on the firebox floor of your stove.

OVERFIRING

Do not overfire. Using flammable liquids or too much wood, or burning trash in the stove, may result in overfiring. If the chimney connector or stove glows red or even worse, white, the stove is overfired. This condition may ignite creosote in the chimney, possibly causing a house fire.

If you overfire, immediately close the stove damper and doors, if open, to reduce the air supply to the fire.

WOOD SELECTION AND STORAGE

Dry and well-seasoned wood will not only minimize the chance of creosote formation but will give you the most efficient fire. Even dry wood contains at least 15% moisture by weight, and should be burned hot enough to keep the chimney hot for as long as it takes to dry it out - about one hour. It is a waste of energy to burn unseasoned wood of any kind.

Dead wood lying on the forest floor should be considered wet and requires full seasoning time. Standing wood can be considered to be about 2/3 seasoned. To tell if wood is dry enough to burn, check the ends of the logs. If there are cracks radiating in all directions from the center, it's dry. If your wood sizzles in the fire, even though the surface is dry, it may not be fully cured. Splitting of wood before it is stored reduces drying time. Wood should be stacked so that both ends of each piece are exposed to air, if space is available, since more drying occurs through the cut ends than the sides. This is true even with wood that has been split. Store wood undercover, such as in a shed, or covered with a tarp, plastic, tarpaper, sheets of scrap plywood, etc.

MAINTENANCE INSTRUCTIONS

CREOSOTE

1. **Formation and need for removal**-When wood is burned slowly, it produces tar and other organic vapors which combine with expelled moisture to form creosote. The creosote vapors condense in the relatively cool chimney flue of a newly started fire or from a slowly burning fire.

As a result, creosote residue accumulates on the flue lining. When ignited, this creosote makes an extremely hot fire which may damage the chimney or even destroy the house.

The chimney connector and chimney should be inspected at least twice monthly during the heating season to determine if a creosote buildup has occurred.

If creosote has accumulated, it should be removed to reduce the risk of a chimney fire.

2. **Inspection and removal**-Inspect the system at the stove connection and at the chimney top. Cooler surfaces tend to build creosote deposits quicker, so it is important to check the chimney from the top as well as from the bottom.

The creosote should be removed with a brush specifically designed for the type of chimney in use. A chimney sweep can perform this service. It is also recommended that before each heating season, the entire system be professionally inspected, and cleaned and repaired if necessary.

ALADDIN STOVE PRODUCTS, INC.
LIMITED WARRANTY

Aladdin Steel Products warrants the Quadra-Fire 2000 and Quadra-Fire 3000 models against defects in materials or workmanship to the original retail purchaser for a period of five years following the date of retail purchase. To secure this warranty, the purchaser must return the warranty card within ten (10) days of the purchase to:

ALADDIN STEEL PRODUCTS, INC.
401 N. Wynne
Colville, WA 99114

The manufacturer is responsible only for repair or replacement of the defective part and may request that the purchaser ship the part to the manufacturer for inspection. The manufacturer is not responsible for special, incidental or consequential damages.

Misusing or altering the stove **VOIDS** this warranty - this includes, but is not limited to, using other than recommended fuels, over heating, and any alterations or modifications.

This warranty does not cover glass, paint, plated surfaces, gaskets and firebrick.

DETACH AND RETURN WITHIN TEN DAYS OF THE DATE OF PURCHASE.

Stove Model _____ Serial No. _____

Date Purchase _____

Purchased from _____

Address _____

Your Name _____

Your Address _____

Installed by: _____ Sell _____ Contractor _____ Other _____

Have you complied with local building codes _____ Yes _____ No _____

Was your stove purchased for a _____ House _____ Cabin _____ Other _____

How did you find out about **Quadra-Fire**

_____ Newspaper _____ Dealer _____ Radio _____ T.V. _____ From a friend _____

Friends that may be interested in **Quadra-Fire**

Name _____ Name _____

Address _____ Address _____

Thank you for buying a **Quadra-Fire** Stove.



CUSTOMER RECORD

Stove Model _____

Serial Number _____

Date Purchase _____

From _____

Aladdin Steel Products, Inc.

401 N. Wynne St.
Colville, WA 99114

Mountain View Hearth Products
manuals.stove-parts-unlimited.com

QUADRA-FIRE

QUADRA-FIRE

PLACE
STAMP
HERE

Aladdin Steel Products, Inc.
401 N. Wynne St.
Colville, WA 99114

Page 16

BRICK PATTERNS

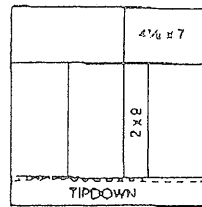

OF 2000

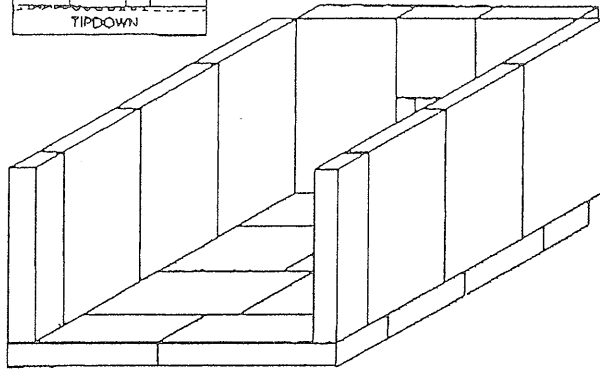

OF 3000

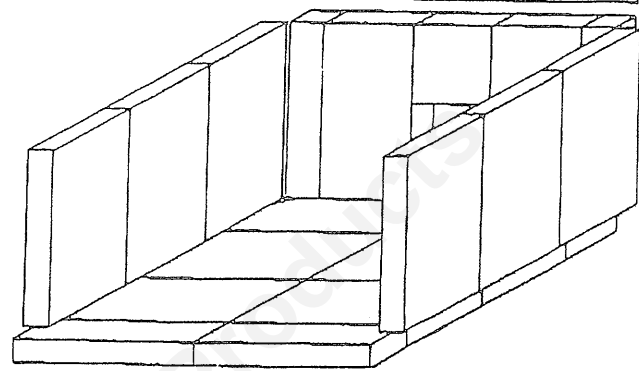
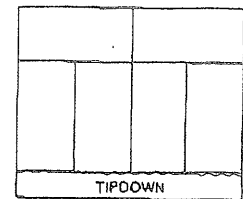

MAINTENANCE INSTRUCTIONS

CREOSOTE

1. Formation and need for removal-When wood is burned slowly, it produces tar and other organic vapors which combine with expelled moisture to form creosote. The creosote vapors condense in the relatively cool chimney flue of a newly started fire or from a slowly burning fire.

As a result, creosote residue accumulates on the flue lining. When ignited, this creosote makes an extremely hot fire which may damage the chimney or even destroy the house.

The chimney connector and chimney should be inspected at least twice monthly during the heating season to determine if a creosote buildup has occurred.

If creosote has accumulated, it should be removed to reduce the risk of a chimney fire.

2. Inspection and removal-Inspect the system at the stove connection and at the chimney top. Cooler surfaces tend to build creosote deposits quicker, so it is important to check the chimney from the top as well as from the bottom.

The creosote should be removed with a brush specifically designed for the type of chimney in use. A chimney sweep can perform this service. It is also recommended that before each heating season, the entire system be professionally inspected, and cleaned and repaired if necessary.

**ALADDIN STEEL PRODUCTS, INC.
LIMITED WARRANTY**

Aladdin Steel Products, Inc. warrants the **Quadra-Fire 2000** and 3000 models against defects in materials or workmanship (except optional electrical component parts) for a period of five (5) years following the date of retail purchase.

Optional electrical component parts are warranted against defects in materials or workmanship for a period of one (1) year following the date of retail purchase. Proof of purchase is required to secure warranty.

To secure this warranty, the purchaser must return the warranty card within ten (10) days of the purchase to:

**ALADDIN STEEL PRODUCTS, INC.
401 North Wynne
Colville, WA 99114**

The manufacturer is responsible only for repair or replacement of the defective part and may request that the purchaser ship the part to the manufacturer or authorized repair facility in your state. Warranty claims should be made directly to the manufacturer at the above address. The manufacturer is not responsible for special, incidental or consequential damages.

Misusing or altering the stove or optional electrical component parts **VOIDS** this warranty - this includes but is not limited to, using other than recommended fuels, over heating, and any alterations or modifications.

This warranty does not cover freight, glass, paint, plated surfaces, gaskets and firebrick.