

# QUADRA-FIRE

*North America's Best*

## Installation, Operation, and Maintenance Instructions Model: Quadra-Fire 1000 Pellet Stoves

(Models 1000 Gold and 1000 Classic)

*Clean Air*

*We Care*

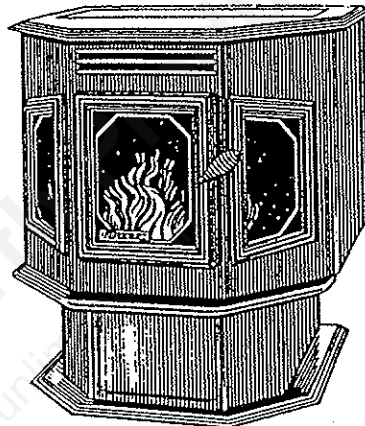

**Also Available in French  
Ask Your Dealer**

**Nous Avons Aussi Le Manuel en Français.  
Demandez à Votre Vendeur**

**CONGRATULATIONS** -- You are now the proud owner of one of the finest stoves in the world for your home -- the **QUADRA-FIRE**.

Now, before installing your stove and building your first fire -- record the serial number on the warranty card.

### **PLEASE READ ALL OF THE OWNER'S MANUAL AND SAFETY NOTES. IMPORTANT SAFETY NOTES.**

- 1 When installing your stove, particular attention should be paid to fire protection. If this unit is not properly installed, a house fire may result. For your safety, follow the installation instructions and contact local building or fire officials about restrictions and installation inspection requirements in your area.
- 2 **Read the operating instructions before you plug in the stove.**
- 3 Always unplug the stove before cleaning or servicing.
- 4 Do not connect the stove to a chimney flue already serving another appliance.
- 5 The stove operates with a negative pressure fire box and a positive pressure exhaust. It is imperative that the chimney system be air tight and installed correctly.
- 6 Dispose of all ashes in a metal container.
- 7 Comply with all minimum clearances to combustibles as shown in this manual.
- 8 The **QUADRA-FIRE 1000** is tested and approved for pelletized biomass fuel only. Burning of any other type of fuel voids your warranty!
- 9 Aladdin Steel Products, Inc., manufacturers of the Quadra-Fire pellet stove, reserves the right to alter its products, their specification and/or price without notice.

ALADDIN STEEL PRODUCTS INC., GRANTS NO WARRANTY, IMPLIED OR STATED, FOR THE INSTALLATION OR MAINTENANCE OF THIS UNIT AND ASSUMES NO RESPONSIBILITY FOR ANY CONSEQUENTIAL DAMAGE(S).

# ALADDIN

ALADDIN STEEL PRODUCTS, INC.

401 N. WYNNE

COLVILLE, WASHINGTON 99114

**SAVE THESE INSTRUCTIONS**

# TABLE OF CONTENTS

	Page
Safety Notes .....	1
Installation .....	3
I Clearances To Combustibles .....	3
II Chimney And Exhaust Connections .....	3
III Floor Protection .....	3
IV Venting Systems .....	4 & 5
A. Alcove .....	4
B. Thru The Wall .....	4
C. Vertical .....	5
D. Thru The Wall And Vertical .....	5
E. Masonry .....	5
F. Alternate Masonry .....	5
Venting Termination Requirements .....	6
Mobile Home Installation .....	6
Thermostat Installation .....	6
Operating Instructions .....	7
Cleaning & Maintenance .....	7 & 8
Top Vent Flue Adapter, Trim Installation & Feed Adjustment Instructions .....	9
Schematics .....	10 & 11
Component list .....	12 & 13
Troubleshooting .....	14 & 15
Warranty .....	16

Quadra-Fire Pellet Stoves are safety tested and listed by Warnock Hersey International to UL 1482, ULC S627, APFI, UM 84-HUD. Also suitable for mobile home installation. This pellet burning appliance has been tested and listed for use in manufactured homes in accordance with OAR 814-23-900 through 814-23-909.

Dimensions:

	Classic	Gold
Width:	29" (737mm)	29.5" (749mm)
Height:	30.5" (775mm)	31" (787mm)
Depth:	25.5" (648mm)	25.5" (648mm)

Heat Output*	40,000 BTU/hr
Particulate Emissions per hr	0.9 g/hr
Fuel Storage Capacity	65Lbs

\*BTU Output will vary, depending on the brand of fuel you use in your stove. Consult with your authorized Quadra-Fire dealer for the best results.

# INSTALLATION

## I. CLEARANCES TO COMBUSTIBLES

### Minimum Clearances To Combustible Materials (U.S. In Inches, Canada In MM)

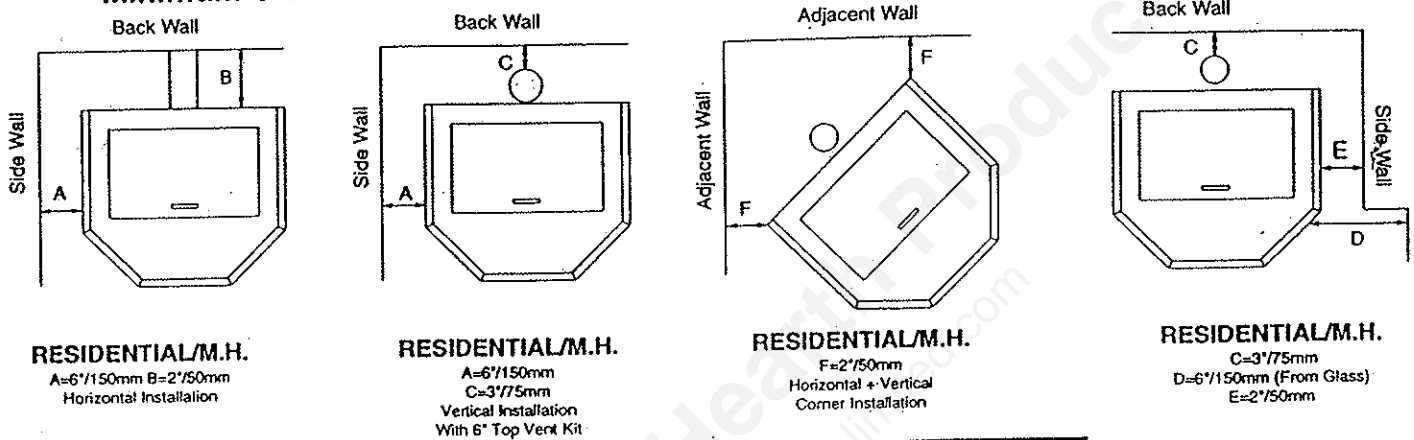

	Rear Vent	Top Vent With 3" Pellet Vent	With 6 Inch Top Vent Kit
Back:	2"/50mm	8"/200mm	9"/225mm
Side:	2"/50mm	2"/50mm	2"/50mm
Corner:	2"/50mm	2"/50mm	2"/50mm
From Side Glass	6"/150mm	6"/150mm	6"/150mm

## II. CHIMNEY AND EXHAUST CONNECTION

1. CHIMNEY & CONNECTOR: Use 3 inch (76mm) or 4 inch (102mm) only diameter type "L" or "PL" venting system.
2. MOBILE HOME: Approved for all listed pellet vent. If using the 3 to 6 inch (76mm to 152mm) vertical top vent kit, you must use listed double wall flue connector to Class A pipe or all Class A pipe. Mobile home must be equipped with a spark arrestor and rain cap.
3. RESIDENTIAL: When using the 3 to 6 inch (76mm to 152mm) vertical top vent kit, it is legal to use 24 GA. single wall flue connector, listed double wall flue connector to Class A listed metal chimneys or masonry chimneys meeting I.C.B.O. standards for wood stove flues.
4. The stove is approved for all 3 or 4 inch (76mm or 102mm) diameter listed pellet vent and it can be either vertically or horizontally vented.

NOTE: All pipe must be sealed, and use welded seam pipe whenever possible.

## III. FLOOR PROTECTION

### Minimum Clearances To Combustible Materials

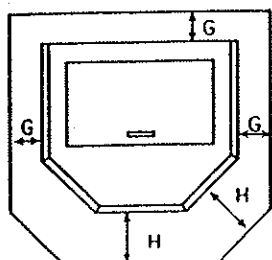

G=2"/50mm  
H=6"/150mm

Floor protector must be 3/8" (10mm) minimum thickness non-combustible material or equivalent, extending beneath heater and to the front/sides/rear as indicated.

# IV. VENTING SYSTEM

## A. Alcove

The QUADRA-FIRE 1000 is approved for the standard alcove height of 72 inches (1830 mm), maximum alcove depth of 60 inches (1525 mm) or for a reduced alcove height of 43 inches (1090 mm) with a minimum of 12.5 inches (320 mm) of clearance from the top of the stove. The maximum alcove depth is 36 inches (915 mm) and the listed sidewall clearances are a minimum of 2 inches (50 mm).

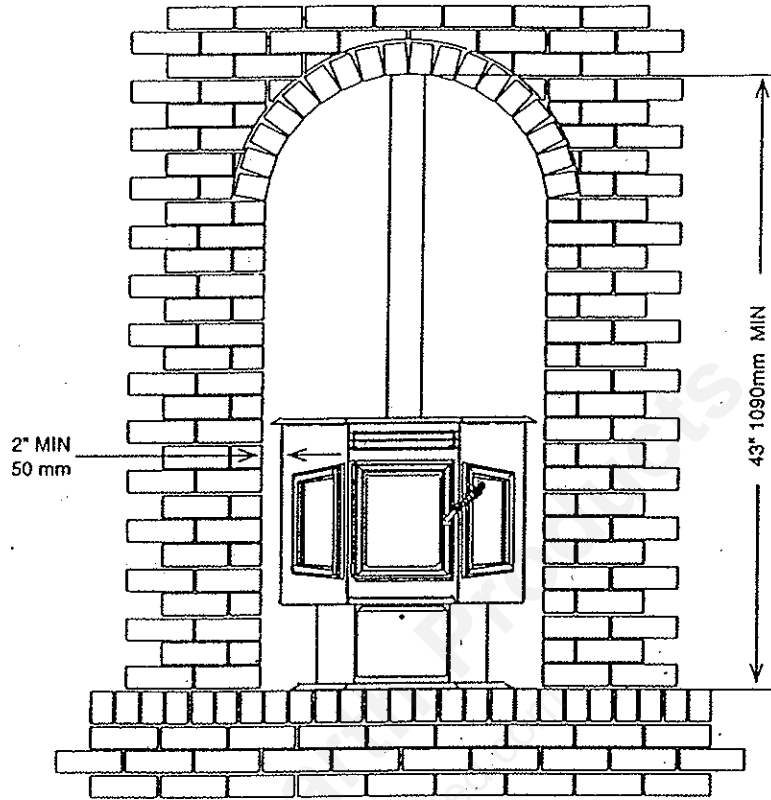

### VENTING SYSTEM RECOMMENDATION

The stove is approved for horizontal exhaust, however we recommend that the exhaust go vertical for eight feet (2.4m), or above the eave of the house. This will help draw smoke out of the stove in the event of a power failure.

## VENTING SYSTEMS

### B. Through the wall.

We recommend going vertical 8' (2440 mm) or above eave.

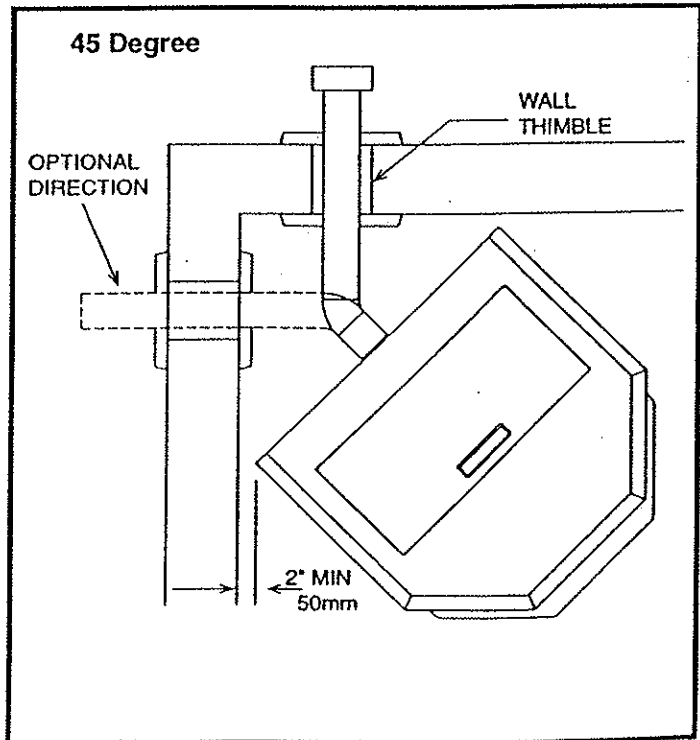
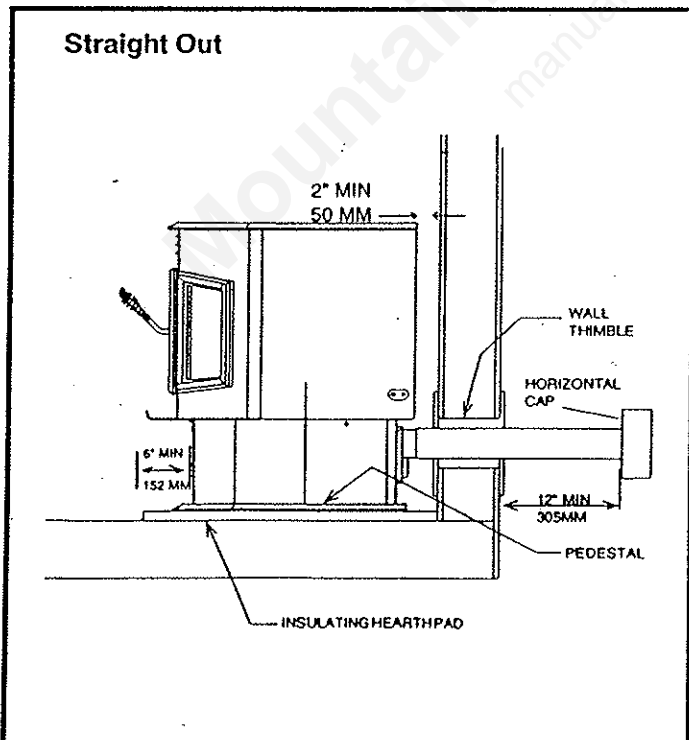

### C. Vertical

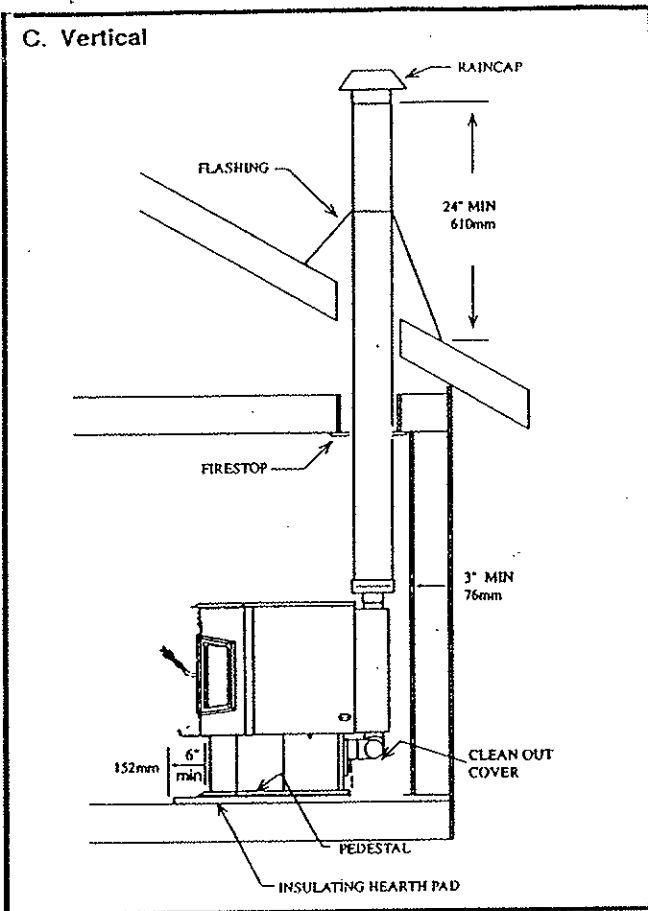

### D. Thru The Wall And Vertical

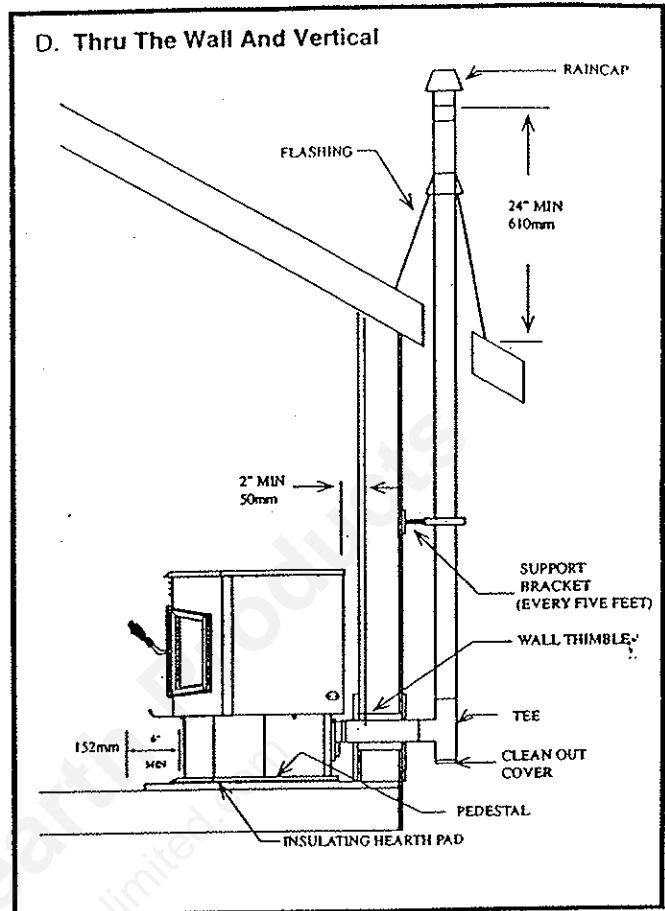

### E. Masonry

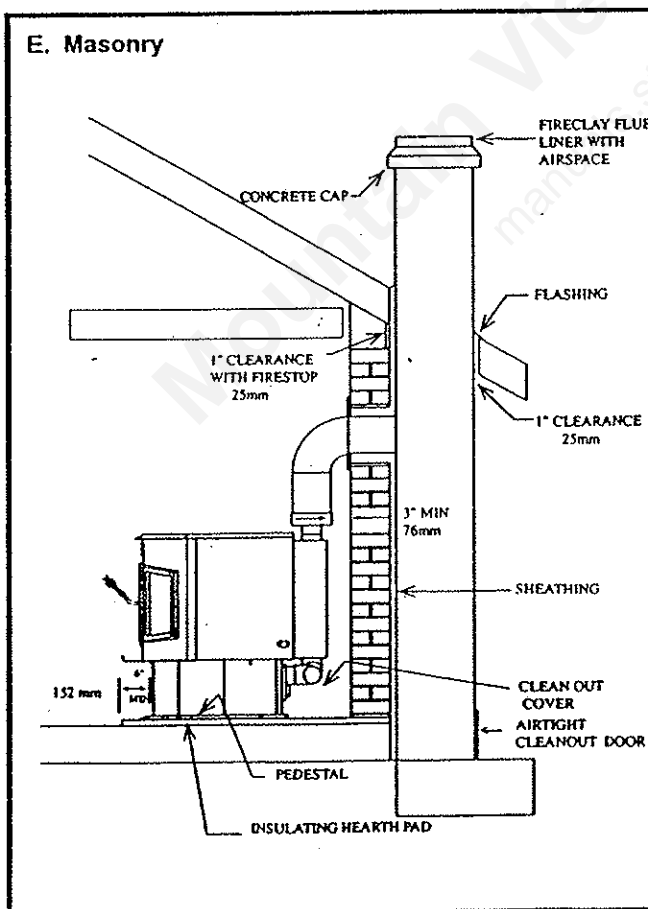

### F. Alternate Masonry

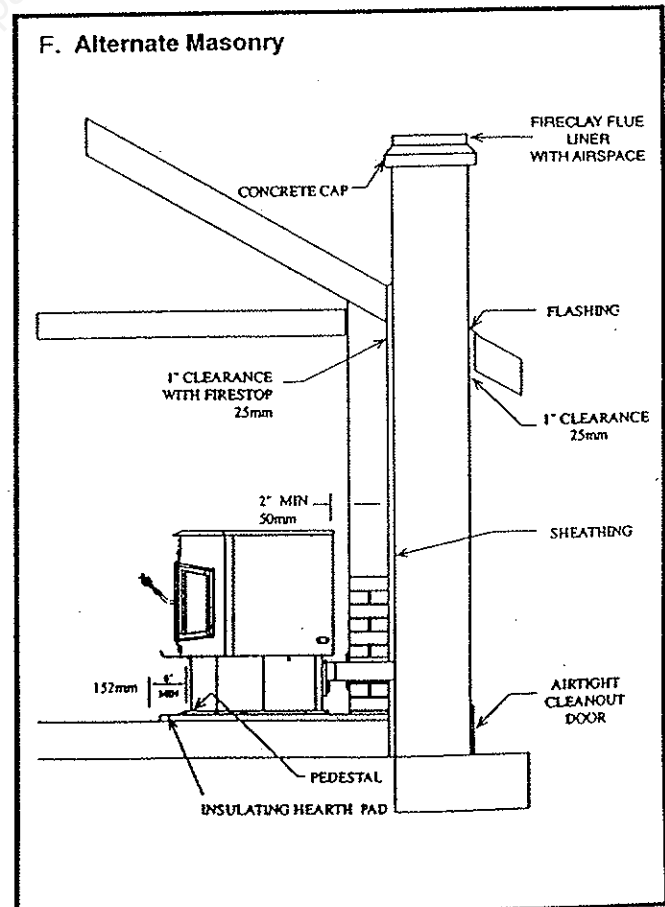

## VENTING TERMINATION REQUIREMENTS

1. Do not terminate vent in any enclosed or semi-enclosed area, such as: carports, garage, attic, crawl space, under a sundeck or porch, narrow walkway or closely fenced area, or any location that can build up a concentration of fumes such as a stairwell, covered breezeway, etc.
2. Vent surfaces can get hot enough to cause burns if touched. Noncombustible shielding or guards may be required.
3. Termination must exhaust above air inlet elevation. It is recommended that at least five feet (1.5m) of vertical pipe be installed when the appliance is vented directly through a wall to create some natural draft to prevent the possibility of smoke or odor during appliance shutdown, and to keep exhaust from causing a nuisance or hazard from exposing people or shrubs to high temperatures. In any case, the safest and preferred venting method is to extend the vent through the roof.
4. Distance from doors and windows, or gravity or ventilation air inlet into building:
  - a. Not less than 4'/1.2m below;
  - b. Not less than 4'/1.2m horizontally from;
  - c. Not less than 1'/305mm above.
5. Distance from bottom of termination and grade - 12"/305mm minimum. This is conditional upon the plants and nature of grade surface. When determining the final termination, use caution due to the heated exhaust gases and fly ash. The grade surface must not be a lawn. Distance from bottom of termination and public walkway - 7'/2.1m minimum.
6. Distance to combustible materials - 2'/510mm minimum. This includes: adjacent buildings, fences, protruding parts of the structure, roof overhang, plants and shrubs, etc.

## MOBILE HOME INSTALLATION

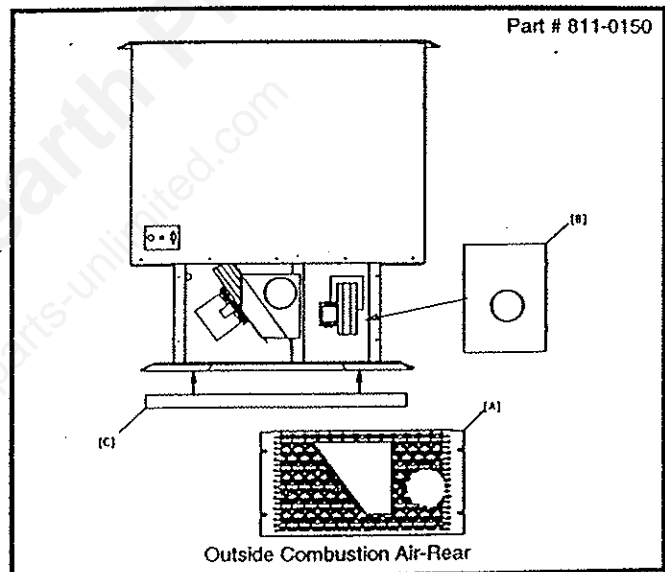
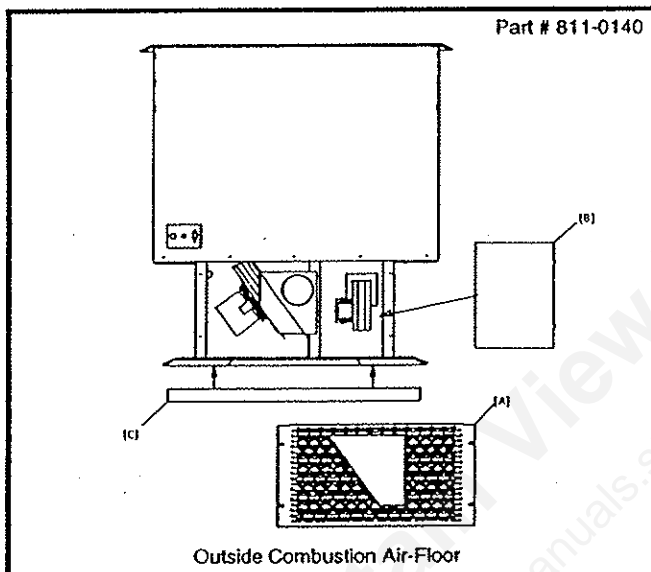

1. An outside air inlet must be provided for the combustion air and be unrestricted while the stove is in use.
2. The stove is to be secured to the mobile home.
3. Do not install the stove in a sleeping room.
4. The structural integrity of the mobile home floor, walls and ceiling/roof must be maintained.
5. The stove is to be grounded with #8 copper grounding wire or equivalent terminated at each end with an N.E.C. approved grounding device.
6. Refer to clearance to combustibles section on page 3 for listings to combustibles and appropriate chimney systems.

## THERMOSTAT INSTALLATION

1. A 24 volt AC thermostat is required to operate this pellet stove. Some thermostats are equipped with an adjustable heat anticipator. Our current rating is .05 amps. The anticipator needs to be adjusted to the lowest setting available.
2. When mounting a thermostat on a wall be sure to follow your thermostat installation instructions carefully. Note: Be sure the thermostat is level for accurate readings. The thermostat should be mounted on an inside wall and not in direct line with the stove convection air. NOTE: If the thermostat is located too close to the stove, you may need to set the temperature setting slightly higher to maintain the desired temperature in your home.
3. There is a four screw terminal block located on the back of the stove beside the fuse receptacle adjacent to the power cord inlet. The top and bottom screws are the mounting screws for the terminal block, THE CENTER TWO SCREWS ARE FOR THE THERMOSTAT WIRES. Attach the red wire to the second screw from the top on the terminal block and the white wire to the third screw from the top.

# OPERATING INSTRUCTIONS

## 1. Fuel Size And Material

- Fuel pellets are basically made from sawdust or wood by-products. If the source material is hardwood, it will have a higher mineral content creating a heavier ash. Minerals and other unburnable materials such as sand will turn into glass when heated to the extreme temperatures our firepot reaches. This is what forms clinkers in the bottom of the firepot. Trees from different areas will vary in mineral content. That's why some fuels make more clinkers than others. Pellets are manufactured in either 1/4 inch or 5/16 inch (6mm or 8mm) diameter and many varying lengths. Pellet length may even vary by lot from the same manufacturer. That's why the feed rate may need to be adjusted occasionally. We recommend that you buy fuel in multiton lots whenever possible. Buying larger quantities of fuel at one time will greatly reduce the number of times the feed adjustments will need to be made. NOTE: This stove will operate properly with either 1/4 inch or 5/16 inch (6mm or 8mm) diameter pellets. However, pellets exceeding 1-1/4 inches (32mm) in length can cause missed ignitions.

## 2. Before Your First Fire

- First make sure your stove has been properly installed and that all safety requirements have been met. Pay particular attention to the fire protection, venting and thermostat installation instructions.
- Now open the front door of the stove and remove all of the accessories that were placed there for shipment. Remove all labels that are affixed to the glass.
- Check the position of the thermocouple and make sure that it protrudes approximately 3/4" to 1" (19mm to 25mm) into the firepot. It may be necessary to slide the thermocouple and protection tube into their proper position. Now close the front door.
- Next open the front pedestal access door with the hex key supplied, CUT the rubber band from the firepot and remove the cardboard packing from underneath the firepot. Unwrap and insert the cleanout plug into its preformed location in the firepot. Now close the front pedestal access door and lock it into place with the door key.
- You are now ready to load fuel, but first see that all the accessories have been removed from the hopper. Now fill the hopper with pellets.
- Remember that a working thermostat is required for proper operation of this stove. At this time set the thermostat to its lowest setting.

## 3. Starting Your First Fire

- Now plug the stove in. The combustion blowers will come on. Even though the thermostat is not calling for heat, the combustion blowers will stay on for approximately eight minutes. This is normal.
- Next adjust the thermostat to its highest setting. The red light, next to the restart button on the right side of the stove, will come on. This will indicate that the thermostat is calling for heat.
- The fuel feed system and the igniter are now turned on. NOTE: The fuel feed system will not run when the front door is open.
- For your first fire, it will be necessary to press the restart button once at approximately two and a half minutes for start-up and again at five minutes. This will fill the feed system and allow the stove to light.
- The stove will now continue to run as long as the thermostat is calling for heat. Once the stove has ignited, let the stove burn for approximately 15 minutes, then set the thermostat to the desired room temperature.

## 4. General Operation Information

- Understand that the stove is like most modern furnaces in that it has only one burn rate, full on. When the thermostat calls for heat, your stove will automatically light and deliver heat in the most efficient and economical way.
- Once all of the start-up procedures have been completed, you simply set the thermostat to a comfortable setting and enjoy the stove, but remember you will have to add pellets. The thermostat location will have some effect on the stove's operation. When the thermostat is located close to the stove, it may require a slightly higher temperature setting to keep the rest of the house comfortable. If the thermostat location is upstairs while the stove is downstairs, you will notice higher temperature near the stove.
- During each ignition cycle, it is normal to see some smoke. The smoke will stop once the fire starts.
- After your stove has been burning for approximately fifteen minutes, the convection blower will automatically turn on. This blower transfers heat from your stove into the room and will continue to run after the thermostat has stopped calling for heat until all of the heat has been extracted from the stove.
- Occasionally, the stove may run out of fuel and shut itself down. If this happens, the red light will be on. To restart the stove, fill the hopper and press the restart button next to the light. When you press the restart button, the red light will go out and when the button is released the light will come back on. You should see a fire in about four minutes. If not, press the restart button again.

# CLEANING AND MAINTENANCE

NOTE: Unplug The Stove Before Any Cleaning And Maintenance!!

## 1. Firepot

It takes very little time to clean the firepot. We recommend that you clean the firepot at least once a week, however, if the fuel you are burning has a high dirt content it will be necessary to clean the firepot more often. Dirty fuel will cause clinkers to form in the firepot. A clinker is formed when dirt or a nonburnable substance is heated to 2000° F (1093° C) and becomes glass-like. When removing clinkers from the firepot some ceramic may stick to the clinker. This is normal with dirty fuel and will not affect the operation of the firepot.

To clean the firepot: A - Disconnect power; B - Open the front pedestal access door; C - Remove cleanout plug from firepot base; D - Open main firebox door; E - Remove clinkers and scrape ash down igniter hole in the bottom of the firepot and into the bottom ashpan; F - Empty ashpan into a metal container. NOTE: Hot embers remain hot for many days. Store in a safe place away from combustibles; G - Reinstall plug, close the cleanout door, and close the main door; H - Reconnect power cord to outlet.

## 2. Fire Box Ash Removal

Clean as needed. First remove the cover plate located just inside the main door in front of the firepot. Then lift out the ashpans and empty into a metal container. NOTE: Hot embers remain hot for many days. Store in a safe place away from combustibles. Replace ashpans and cover plate and resume stove operation.

### 3. Heat Exchanger Maintenance And Cleaning

There are two aluminum finned heat exchangers in the stove. They should be inspected after each ton of fuel and cleaned if necessary. **NOTE: Clean Only When Stove Is Cold.** The large heat exchanger is located at the top of the firebox and is accessible through the front door. To do this, remove the large top stainless steel cover by sliding it upwards towards the door. It should then fall into your hands. Clean the heat exchanger with a brush and vacuum out the ashes. If the large heat exchanger is extremely dirty, you should remove the small stainless steel cover located against the back of the firebox. **NOTE: Remove ashpans before removing small heat exchange cover.** To remove cover, place a screwdriver into the feed tube and lift upwards, it should then pull forward towards you. The small rear heat exchanger is now exposed and may be cleaned with a bottle brush or similar item. Vacuum the area behind this and then reinstall the cover plates and ashpans.

### 4. Venting System

The venting system should be inspected and cleaned at least once a year or more often depending upon the quality of your fuel. If you are experiencing nuisance shutdowns check for a clogged exhaust system. If the exhaust is restricted, the vacuum safety switch will shut the stove off (the red light will remain on).

### 5. Door And Latch Adjustment

To adjust the door hinges the door must be removed. To do this, first open the door and loosen the lock nuts on the hinges behind the face. Then remove the top hinge pin and lift the door up and off the lower hinge. The hinges are then turned in or out to adjust. Next, replace the door and tighten the lock nuts.

The door latch is adjusted by removing the nut on the back of the door latch. Remove the latch cam and square key and add or subtract a washer to space the cam as needed.

### 6. Blowers

#### A. Positive Combustion Blower (30 CFM)

This blower should be checked for dust accumulation every six months. To clean it, remove the pedestal cover on the lower left side of the stove. Remove cover plate screw on the blower (be sure to note air shutter position), open plate, use brush & vacuum to clean impellers, and return air shutter to its proper position.

Note: This blower requires no lubrication.

#### B. Negative Combustion Blower (80 CFM)

Fuel quality is the factor for determining how often this blower should be cleaned. With good fuel the impellers should not have to be cleaned more than once a year, with poor fuel it will need to be cleaned more often. To clean it, remove the pedestal cover on the lower right side of the stove. Then remove the four nuts holding the blower to the mount. Next remove the two nuts from the exhaust port of blower which will release the blower from the stove. Note: Now is a good time to clean the rear heat exchanger. In cleaning the impeller and housing, take care not to bend the impeller blades. Before reinstalling the blower, check to see that the impeller set screws are tight on both impellers. Note: This blower requires no lubrication.

#### C. Convection Blower (160 CFM)

This blower will require cleaning at the beginning of each heating season. To clean this blower, remove the left side panel to access the blower. Use a brush & vacuum to clean the impellers. Note: This blower requires no lubrication.

### 7. Reading The Fire & Adjustment Procedures

A properly adjusted fire has a short active flame pattern, that extends out of the firepot two to four inches (50mm to 102mm). If the fire has tall flames with black tails and seems somewhat lazy, the feed rate will need to be reduced. Start adjusting this type of fire by sliding the feed adjustment rod down about 1/2 inch (13mm)(see feed adjustment instruction pg. 9). Within fifteen minutes, your adjustment will have taken affect. If the fire is still too tall, lower the feed adjustment plate again. If the fire is still lazy and you have reached the end of travel for the feed adjustment plate, you will need to increase the combustion air. Start by removing the set screw on the 30 CFM blower air adjustment plate and open it in 1/4 inch (16mm) increments until the fire has a nice active flame pattern.

When the fire is too small and rarely peaks above the top of the firepot, you will need to increase the feed rate by adjusting the plate upwards. If the feed adjustment plate reaches the end of its travel and the fire is still low and very active, you will need to close the air adjustment on the 30 cfm combustion blower until the flame is properly adjusted.

## TOP VENT FLUE ADAPTER INSTRUCTIONS

### INSTALLATION INSTRUCTIONS

- 1) Put a layer of silicone on the 3" (76mm) exhaust outlet
- 2) Slide the flue adapter on to the rear exhaust outlet
- 3) Adjust the assembly to a vertical position
- 4) Slide the outer shield up or down to mate evenly with the top of stove
- 5) Tighten the adjusting screws (A) when the shield is in the proper position
- 6) Drill six holes (B) with #26 drill bit (provided) into the back of the stove using the outer shield as a pattern (make sure the assembly is vertical)
- 7) Insert the mounting gaskets between the stove and the outer shield
- 8) Install the six mounting screws (B)
- 9) Install the stove pipe into the 6" adapter (be sure to silicone all joints)

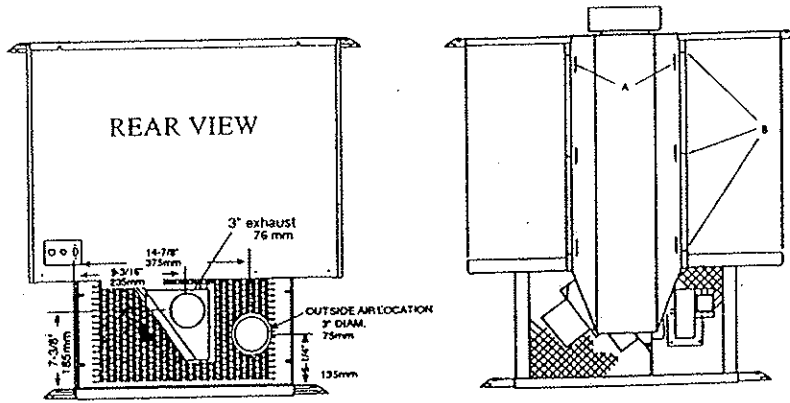

## TRIM INSTALLATION INSTRUCTIONS

For 1000 Gold models only

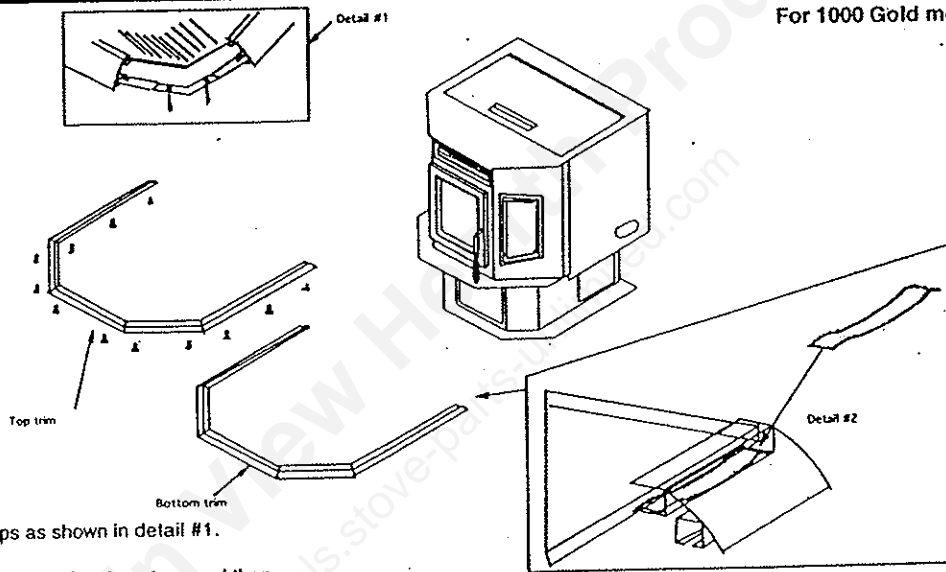

- STEP 1** Install corner clips as shown in detail #1.
- STEP 2** Slide the top trim on to the stove top, and then tighten the mounting screws.
- STEP 3** Slide the bottom trim assembly onto the pedestal base. Then insert the spring clip from the rear as shown in detail #2

## FEED ADJUSTMENT INSTRUCTIONS

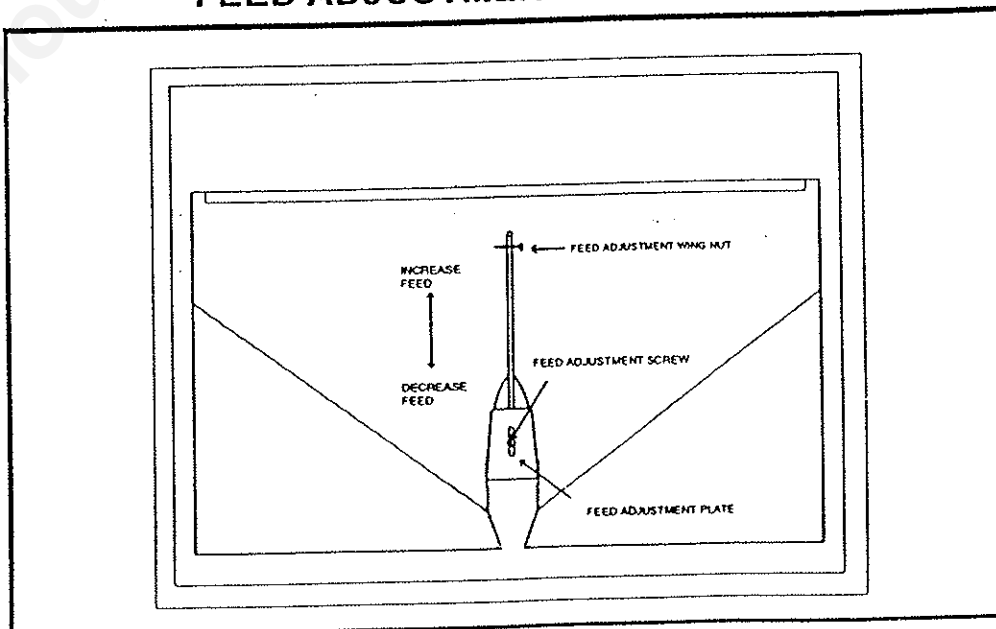

# SCHEMATIC

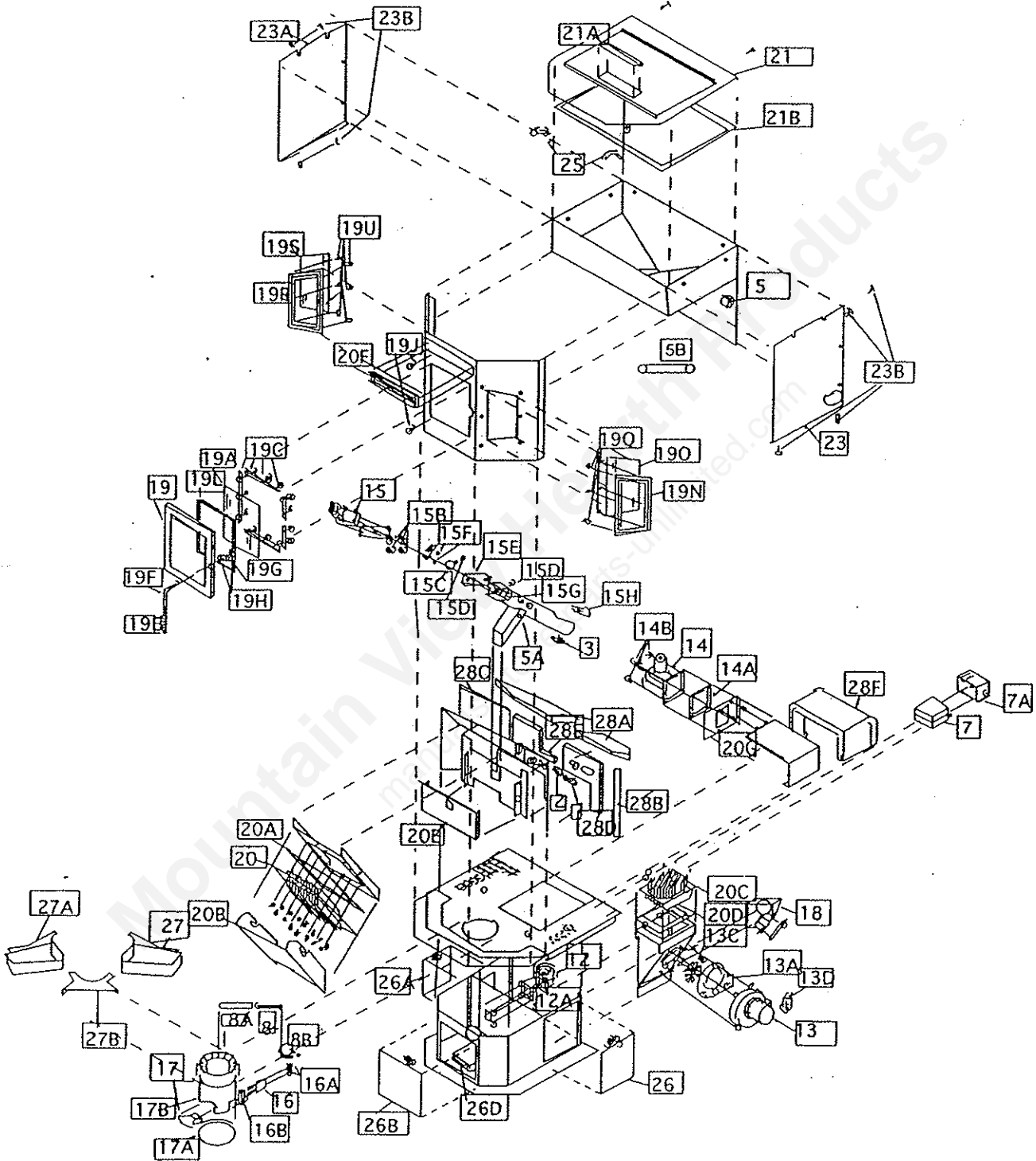

## SCHEMATIC KEY

Description	PG	Schematic#	Description	PG	Schematic#
Electrical Cord	12	1	Front Door Glass Frame		19C
Fuse Holder	12	2	Handle Spring 1/2"		19E
Light Base	12	3	Handle Rod 1/2"		19F
Light Lens	12	3A	Handle Cam		19G
Vacuum Switch		5	Handle Washers (1)		19H
Brass Hose Fitting		5A	Front Door Adjustable Hinges (2)		19J
Rubber Vacuum Hose		5B	Front Door Hinge Pins (2)		19K
Thermostat Terminal Block	12	6	Front Door Gasket		19L
Control Box		7	Right Side Window Frame		19N
Junction Box		7A	Right Side Glass (Clear) w/Gasket		19O
Thermocouple		8	Right Side Mounting Screws		19Q
Thermocouple Ceramic Cover		8A	Left Side Window Frame		19R
Thermocouple Wire Relief		8B	Left Side Glass (Clear) w/Gasket		19S
Thermocouple Terminal Block	12	8C	Left Side Mounting Screws		19U
Snap Disc #1 (Conv. Blower)		9	Heat Exchanger Front (Large)		20
Snap Disc #2 (Thermostat Override)		10	Heat Exchanger Front Gasket		20A
Snap Disc #3 (Auger Protector)		11	Heat Exchanger Baffle Cover (Large)		20B
Blower #1 (30 CFM Pos.)		12	Heat Exchanger Rear (Small)		20C
Blower #1 Gasket		12A	Heat Exchanger Rear Gasket		20D
Blower #2 (80 CFM Neg.)		13	Heat Exchanger S/S Cover Rear (Small)		20E
Blower #2 Gasket		13A	Heat Exchanger Louvers		20F
Blower #2 Impeller		13C	Rear Heat Exchanger Cover		20G
Blower #2 Exhaust Gasket		13D	Top Assembly		21
Blower #3 (160 CFM Conv.)		14	Hopper Lid Handle		21A
Blower #3 Gasket		14A	Hopper Gasket		21B
Blower #3 Nuts (3) Screw (1)		14B	Right Side Cover (Facing Stove)		23
Feed Motor		15	Left Side Cover (Facing Stove)		23A
Feed Motor Mounting Screws (4)		15B	Top Assembly Wing Nuts		25
Feed Motor Coupler		15C	Pedestal Door Right Side		26
Feed Motor Coupler Set Screws (2)		15D	Pedestal Door Left Side		26A
Nylon Bushing		15E	Pedestal Door Front		26B
Bushing Mounting Nuts (2)		15F	Pedestal Ash Pan		26D
Feed System Coil Spring		15G	Firebox Ash Pan Right Side		27
Feed Adjustment Rate		15H	Firebox Ash Pan Left Side		27A
Igniter		16	Firebox Ash Pan Center Cover		27B
Igniter Ceramic Wire Nuts (2)		16A	Insulation Firebox Top		28A
Ceramic Firepot And Plug		17	Insulation Firebox Right Side		28B
Firepot Gasket		17A	Insulation Firebox Left Side		28C
Exhaust Transition Box		18	Insulation Firebox Rear Right		28D
Front Door		19	Insulation Firebox Rear Left		28E
Front Glass (Clear) w/Gasket		19A	Insulation Conv. Blower Housing		28F

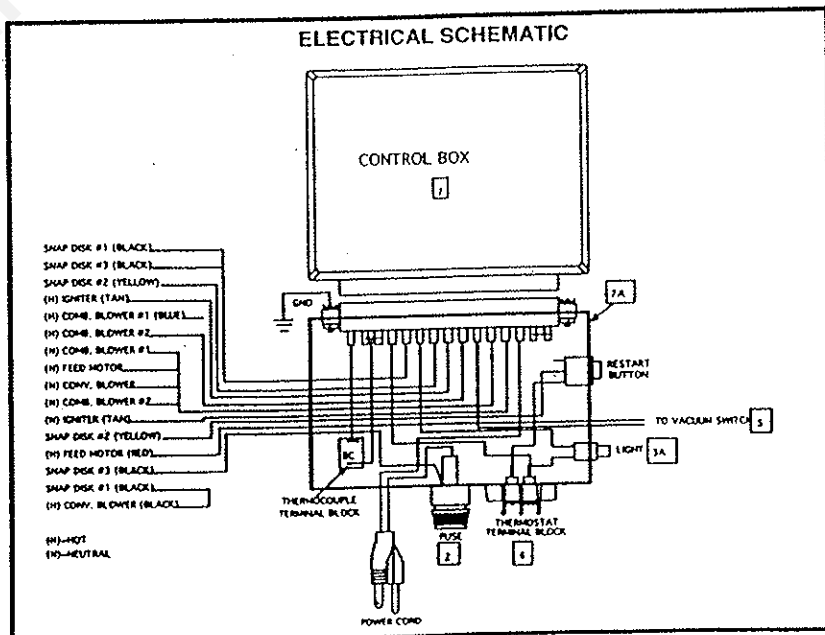

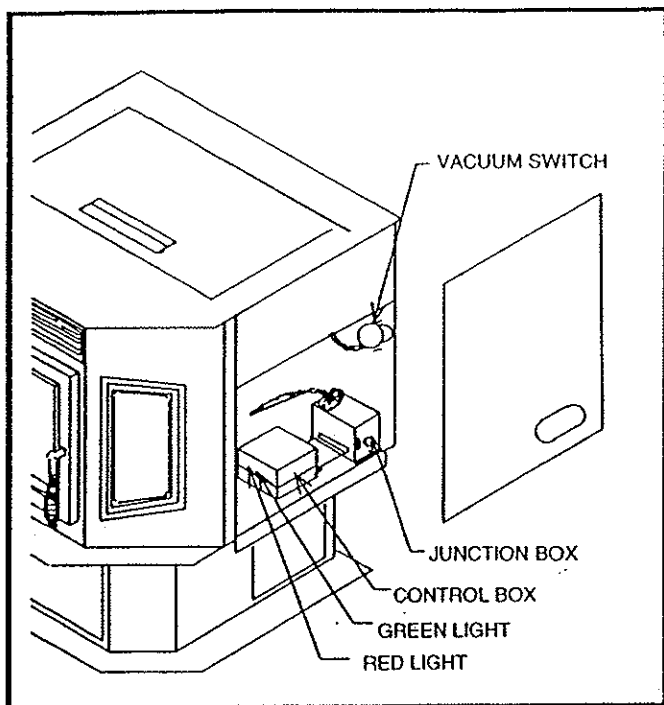

## COMPONENT INFORMATION

### 1. POWER SUPPLY

- A. Check wall receptacle for 120 volt, 60 Hz (standard current). Make sure the outlet is grounded and has the correct polarity.

### 2. FUSE

- A. The fuse is located in a holder on the backside of the stove next to the power cord. To inspect the fuse, push in and turn the fuse holder cap counterclockwise then pull out. Replace with a standard 7 amp, 120 volt fuse if necessary. If the fuse continues to blow, contact your local dealer.

### 3. LIGHT

- A. The light is located on the right hand side next to the reset button. The function of the light is to indicate that the thermostat is calling for heat.
- B. If the thermostat is calling for heat, the stove is burning, and the light is not on, check the bulb. Replace with a 28 volt (#85 lamp) bulb.

### 4. RESTART BUTTON

- A. The reset button is located on the right hand side next to the call light. The function of the button is to momentarily open the thermostat circuit which restarts the system. However, this will only work when the thermostat is calling for heat and the red light is on.
- B. If the light is on, no fire, and there is fuel in the firepot, push the restart button, wait for ignition, you should have fire within four minutes.
- C. If the light does not go out when button is depressed, switch may be faulty. Contact your local dealer.

### 5. VACUUM SWITCH

- A. The vacuum switch is located on the back wall above

junction box on the right side body of the stove. This switch turns the feed system on when vacuum is present in the firebox. Check the rubber hose for leaks or cracks if the feed system fails to start. Also, be sure there is no restriction in the exhaust system and the exhaust blower is running. The vacuum switch is a safety device to shut off the feed motor under the conditions above.

### 6. THERMOSTAT

- A. The stove is designed to run on a 24 volt AC thermostat. Remove the front cover and check to see that the contact points are not stuck in either the open or closed position and that both wires are properly connected to the thermostat. NOTE: The anticipator should be set on the lowest settings available. Also check wire leads at terminal block, located at back of the stove, for loose connections. Manual thermostats have proven to be more accurate & reliable with the pellet stoves.

### 7. CONTROL BOX (BLACK BOX)

- A. The control box is located on the upper, right hand side of the stove. It is plugged into the junction box. If the stove has just been plugged in and combustion blowers did not start, check the control box to see that it is securely plugged in. If this does not solve the problem, go to pg. 14, # A.
- B. The green light located on the front of the control box notifies you that the stove has reached a temperature of 200° F (93° C) in the firepot. If this light is not lit in the first three to four minutes of operation, the stove will shut down. Check the thermocouple.
- C. The red light located to the left of the green light is to indicate that the stove has reached operating temperature of at least 1000° F (538° C). If this light does not come on within the first 9 minutes of start up, the stove will shut down. The stove will not try to relight again by itself. You must manually push the restart button to start the cycle over.
- D. Disconnect the power supply to the stove, then remove control box (BLACK BOX) and take it to your nearest QUADRA-FIRE dealer for testing. NOTE: Do not open the CONTROL BOX, this will void your warranty!

### 8. THERMOCOUPLE

- A. The thermocouple is located on top of the firepot inside of the ceramic protection tube. Remove the ceramic tube and inspect the thermocouple for deterioration or breakage.
- B. Check the terminal block screws to see if they are tight and making a good electrical connection. NOTE: The yellow wire is connected to the terminal located closest to the front of the stove. The red wire is connected to the terminal closest to the rear of the stove.
- C. Upon reinstalling the ceramic cover, be sure the thermocouple is touching the inside end of the ceramic cover and the cover is extending 3/4" to 1" (19mm to 25mm) into the firepot.
- D. The thermocouple controls the turning on and off of the red and green lights on the control box.

### 9. SNAP DISC #1 (Convection Blower)

- A. Snap disc # 1 is located on the upper, right hand side of the stove. It is the first snap disc (1-black, 1-purple wire leading into snap disc) on the left in the insulation board. The function of this snap disc is to turn the convection blower (heated air into the room) on and off as needed.

#### 10. SNAP DISC #2 (Thermostat Override)

- A. Snap disc # 2 is located on the upper, right hand side of the stove. It is the second snap disc (2-yellow wires leading into snap disc) on the left in the insulation board. This snap disc will turn the stove off if an overfire condition occurs or if the convection blower should fail to operate. After the stove cools, the snap disc will automatically reset itself and the stove will relight.

#### 11. SNAP DISC #3 (Back Burn Protector)

- A. Snap disc # 3 is located on the upper, right hand side of the stove, on the feed tube. If for any reason the stove tries to burn back into the feed system or push exhaust up the feed tube, this snap disc will shut the entire system off. However, sometimes in shipment this disc will trip and shut power off to the entire stove. To reset, unplug the stove and push red button in the center of the snap disc in and then plug the stove back in.

#### 12. BLOWER #1 (Positive Draft 30 CFM)

- A. This blower controls the height and velocity of the fire. It is located on the lower left hand side of the pedestal Chimney draft, outside air, or some airtight homes can affect fire height and ignition time. Should the fire be too high or too low, adjustment of the air intake may be necessary. Opening the intake will reduce flame height, closing the intake will raise flame height, but may cause ash buildup in the firepot.

#### 13. BLOWER #2 (Negative Draft 80 CFM)

- A. This blower creates a slight negative pressure (partial vacuum) in the firebox. It is located on the lower right hand side of the pedestal. It works in conjunction with the 30 cfm blower to create a proper burn. If this blower should shut down or fail, a positive pressure will exist in the firebox. As a result, the vacuum switch will shut down the feed system. (Door must be closed for feed motor to work!)
- B. Check electrical leads at the blower for power.
- C. Check both impeller blade set screws for tightness. Check mounting nuts for tightness. Check gasket for wear. See cleaning and maintenance for blower removal.

#### 14. BLOWER #3 (Convection 160 CFM)

- A. The 160 cfm blower pushes the heated air into the room. It is located on the upper left hand side of the stove. This blower must come on within 10 to 15 minutes after ignition or the stove will overheat and cycle on and off. Check wiring connections at blower and snap disc #1 which controls this blower.
- B. Check impeller set screws for tightness (also the mounting nuts and screws).

#### 15. FEED SYSTEM

- A. The feed system is located beneath the top of the stove and centered in front of the hopper. To access, remove the top four wing nuts, 2 are located inside the hopper at the back and two in the front of the hopper

behind the side curtains near the face. This system pulls pellets by using a hollow spring auger up the feed tube from the hopper and drops them down the feed chute into the firepot. If you are having fuel problems, check the following:

1. Check the ramp feeding the firepot in the firebox to see that it is free of fuel or other materials (i.e. sawdust, foreign objects).
2. Check the set screws on the end of the motor shaft to see that it is tight and not slipping.
3. Check the electrical power to motor.
4. Check vacuum hose connections.

#### 16. IGNITER

- A. The igniter is located in chamber at the bottom of the firepot. It may be visually inspected by removing the cleanout plug. NOTE: The element on the igniter is extremely brittle. Be very careful in handling it.
- B. Check the wire leads to the igniter for loose or bad connection (ceramic wire nuts). Note: Unplug stove before checking wire nuts.

#### 17. CLEANOUT PLUG AND FIREPOT

- A. Clean firepot (see section on cleaning and maintenance).
- B. Make sure the cleanout plug in the bottom of the firepot is pushed in all the way.
- C. Check the gasket between the firepot and firebox bottom. A bad seat will affect ignition time and flame height.

#### 18. EXHAUST

- A. If the exhaust is dirty or plugged, the vacuum switch will keep the feed system from coming on. Check the chimney system and exhaust for blockage. The chimney & exhaust system should be cleaned before every heating season.

#### 19. DOOR GASKET

- A. Check the door gasket to see that the door is going completely closed and that there are no air leaks. This can be done by closing the door on a piece of paper and checking that the paper is firmly held in place. If adjustment should be necessary, refer to the cleaning and maintenance section.

#### 20. HEAT EXCHANGERS

- A. There may be a little smoke at the time of the first fire. This is normal. If smoke persists check the seal on the heat exchangers for leaks and tighten mounting bolts. (See cleaning and maintenance - heat exchangers).

#### 21. HOPPER

- A. Check for fuel.

#### 22. THIS IS NORMAL

- A. Both combustion blowers do come on when the stove is first plugged in or directly after a power failure. They will run for approximately 8 minutes.

#### 23. POOR FUEL

- A. Some pellets have a high ash content and/or dirt content than others. You may burn these fuels, but more frequent cleaning of the firepot (heat exchangers, blowers & exhaust system) will be necessary.

# TROUBLESHOOTING

NOTE: In order to identify the components location refer to the schematic on page 10.  
Caution: Unplug stove before servicing.

## A. PLUG IN STOVE - NO RESPONSE

1. Check the power supply for 120 volts.
2. Check the fuse in junction box (7 amp, 120 volt fuse AGC-7).
3. Check snap disc #3 (unplug stove before checking; push reset on snap disc #3).
4. Control box (consult dealer).

## B. CALL LIGHT ON - NO FIRE, NO FUEL IN FIREPOT

1. Check hopper for fuel, sawdust or bridging of pellets in the bottom of the hopper.  
Note: Stove may stop feeding while there are some pellets in hopper. If so continue to check area below.
2. Make sure exhaust blower is operating (80 cfm).
3. Check venting system for obstructions that might cause restrictions and cause vacuum safety switch to shut off the auger.
4. Check the heat exchanger system for high ash contents. If build up is present, clean the heat exchanger system
5. Push restart button and try to light the stove again.

## C. CALL LIGHT ON - NO FIRE, PARTIALLY BURNED FUEL IN FIREPOT

1. Clean the firepot and check that the igniter hole & fuel ramp are clean and the plug is tightly in place.
2. Inspect the thermocouple and cover
  - a. The cover needs to make contact with end of the thermocouple.
  - b. The thermocouple should protrude approximately 3/4 to 1 inch (19mm to 25mm) into the firepot.
  - c. Push the restart button - the thermocouple test lights located on the control box will automatically turn on. When the thermocouple reaches 200° F (93° C) the GREEN LIGHT comes on, and at 1,000° F (538° C), the RED LIGHT comes on. If they fail to turn on after the fire starts, the thermocouple may need replacement.
  - d. The stove is possibly not reaching 200°F (93° C) temperature because of lack of fuel. Check fuel supply and possibly need to increase fuel feed rate (pg 9).

## D. LIGHT ON - NO FIRE - FUEL IN FIREPOT

1. Clean the firepot (probably a bridging problem at the ignition hole located at the bottom of the firepot).
2. Push the restart button.
3. Check the igniter to see if it comes on; if it does not;

- a. Check the connection under the firepot (ceramic wire nuts).
- b. Make sure the igniter is properly installed tightly, and centered in the igniter hole in the firepot.

## E. SLOW OR SMOKY START-UP

1. Clean the firepot & check the firepot gasket for a good seal between the firepot and the firebox.
2. Check the 30 cfm and 80 cfm combustion blowers to make sure that they are working.
3. Visually check cleanliness of the firebox, the heat exchanger and the venting.
4. The feed rate may be too high. Adjust, if necessary, by the fuel adjustment rod located in the hopper.
5. Due to elevation, the air adjusting plate on the 30 cfm blower may need to be adjusted to get the right air to fuel ratio.

## F. RUNS FOR 10 MINUTES - THEN STOPS FEEDING FUEL

1. Inspect the thermocouple and cover
  - a. The cover needs to make contact with end of the thermocouple.
  - b. The thermocouple should protrude approximately 3/4 to 1 inch (19mm to 25mm) into the firepot.
  - c. Push the restart button - the thermocouple test lights located on the control box will automatically turn on. When the thermocouple reaches 200°F (93° C) the GREEN LIGHT comes on, and at 1,000°F (538° C), the RED LIGHT comes on. If they fail to turn on after the fire starts, the thermocouple may need replacement.
2. Check the control box (consult dealer).
3. Check G.

## G. FEED SYSTEM FAILS TO START

1. Make sure that the front door to the firebox and the door to the ash cleanout in the pedestal are closed tightly.
2. Check to make sure that the exhaust (80cfm) is coming on and working:
3. Check heat exchangers and venting system for obstructions or heavy ash build up.
4. Vacuum switch hose may be plugged
  - a. Pull the hose off and blow through it to make sure it is clear. Note: Unplug stove from power outlet.
5. Down drafts or poor venting systems that do not follow manufacturers recommendations can also cause this problem.
6. Check the hopper and the feed system for blockage.

**H. THERMOSTAT WILL NOT START UNIT**

1. Check power to the stove
  - a. Unplug for 10 seconds, plug in. The 30 & 80 cfm blowers should come on, if they do go to #3.
2. The thermostat or thermostat wiring may be faulty.
  - a. Disconnect the thermostat wires from the terminal block located on the back of the stove. Make a jumper wire in order to create a manual bypass to determine if it is the stove or the thermostat. Note: Unplug the stove while hooking up the jumper wire. Plug stove back in and the unit should come back on and light. If the unit lights, check the thermostat and the wires connecting them.
3. Snap disc #2 would cause this if an overheat situation occurs. The snap disc should reset itself once it cools down.
4. Snap disc #3 will need to be manually reset if the unit had overheated.
5. Check the control box (consult dealer).

**I. UNIT FAILS TO SHUT OFF**

1. Check the thermostat and the thermostat wires
  - a. Remove one of the thermostat wires from the terminal block (the stove should go into a normal shutdown cycle).
2. Check the control box (consult dealer).
3. Check the junction box (consult dealer).

**J. SMOKE FROM THE CONVECTION AIR OUTLET**

1. Check the exhaust blower system and all the venting connections.
2. Most smoke in house problems stem from poor venting. Inspect all venting.

**K. CONVECTION BLOWER KEEPS RUNNING OR FAILS TO START**

1. Snap disc #1 may need to be replaced.
2. Check the wire connection on snap disc #1 and the convection fan to make sure a good connection is being made.
3. Check the convection blower.

**L. UNIT CYCLES ON AND OFF - THERMOSTAT ALWAYS ON**

1. Check that snap disc #1 is coming on and turning the convection blower on, or snap disc #2 will be shutting the feed system off until it cools, and resets itself.

**M. LARGE FIRE, ASH BUILD UP & DIRTY GLASS**

1. Clean the firepot and check the firepot gasket for a good seal between the firepot and the firebox surfaces.
2. Visually check the cleanliness of the firebox, the heat exchanger and the venting.
3. Reduce the feed rate, if necessary, to maintain a fire height of about 2" to 4" (50mm to 102mm) above the top of the firepot.
4. If all of the above does not help, it may be possible that an air adjustment on the 30 cfm blower is needed. Open more to increase the air which will help even the air to fuel ratio.

**N. UNIT BURNING - NO CALL LIGHT**

1. Replace light bulb (#85 lamp).

**O. STOVE IGNITES - GOES OUT - LIGHT STILL ON (NUISANCE SHUT DOWN)**

1. Inspect the thermocouple and cover
  - a. Make sure that the thermocouple end and cover make contact.
  - b. The thermocouple and cover should extend approximately 3/4" to 1" into the firepot.
  - c. Push the restart button - the thermocouple test lights located on the control box will automatically turn on. When the thermocouple reaches 200°F (93° C) the GREEN LIGHT comes on, and at 1,000°F (538 C), the RED LIGHT comes on.
2. Check the fire height (2 to 4 inches (50mm to 102mm) out of the firepot)
  - a. Too high of a fire will lower vacuum in the firebox and the vacuum switch may turn off the feed system; resulting in a total shutdown or feed system shutdown until vacuum is regained. NOTE: This may happen with complicated venting systems or at high altitudes. Use the feed adjustment plate to slow fuel input and reduce the fire height. If this does not help, check the air adjusting plate.
  - b. Too low of a fire will let the firepot temperature drop below 1000°F (538° C) and will turn the stove off. Increase fuel, check for sawdust and bridging of pellets.
3. Check the heat exchanger and the venting system for buildup or restriction (clean out ash build up).
4. Check the vacuum switch for proper operation
  - a. Make sure that the vacuum hose is not clogged.
  - b. With normal operation, the vacuum switch should shut the feed system off when the door is opened and restart the feed system when the door is closed again.



*North America's Best*

## LIMITED WARRANTY

ALADDIN STEEL PRODUCTS INC., warrants the QUADRA-FIRE 1000 pellet stove to the original purchaser, for a period of 5 years from date of purchase, to be free of defects in material and workmanship. This warranty gives you specific legal rights and you may have other rights which may vary from state to state.

ALADDIN STEEL PRODUCTS INC., shall not be liable for incidental or consequential damages or commercial loss.

This warranty is limited to defects in material and workmanship and it does not apply to loss or damage which is the result of accident, misuse, negligence, improper installation or any other cause occurring after delivery to the ORIGINAL PURCHASER. No person is authorized to extend or enlarge any liability or obligation which ALADDIN STEEL PRODUCTS INC., may have in connection with the sale of the pellet stove.

No repair or replacement costs will be honored without approval of ALADDIN STEEL PRODUCTS INC.

All replacement parts must be returned to your authorized ALADDIN STEEL PRODUCTS INC., dealer at purchasers expense for inspection prior to repair or replacement.

This warranty does not include or cover the cost of labor involved in removing or replacing a defective part, all of which must be borne by the original purchaser.

All electrical components are warranted for a period of one year from date of purchase. The electrical control box is sealed and cannot be opened or tampered with - without the authorization of ALADDIN STEEL PRODUCTS INC., or your authorized QUADRA-FIRE dealer. Doing so will void your warranty.

### S-7 Firepot warranty:

The S-7 firepot is covered by a full three (3) year warranty. Note: This warranty does not cover normal erosion from usage, igniter, degradation from poor quality fuel or contaminated fuel, and customer damage.

Glass, painted surfaces, gaskets, insulation board, plated surfaces or ceramic parts are not covered under this warranty.

### — IMPORTANT —

This warranty is not valid unless the warranty registration card has been properly completed in full and returned within 30 days from the date of purchase.

The defective stove or part is promptly delivered, with all freight and handling charges prepaid, to ALADDIN STEEL PRODUCTS INC., or your authorized QUADRA-FIRE dealer from which the stove was purchased.

For your records:

DATE PURCHASED \_\_\_\_\_ MODEL# \_\_\_\_\_

AUTHORIZED DEALER \_\_\_\_\_ SERIAL # \_\_\_\_\_

Copyright, Aladdin Steel Products Inc., 1995