

QUADRA-FIRE®

TUBE CHANNEL ASSEMBLY REPLACEMENT INSTRUCTIONS

PART:

SRV7033-023

SRV7039-004

FOR WOOD APPLIANCES:

2100 MILLENIUM
3100 MILLENIUM
4300 SERIES

DISCOVERY I
DISCOVERY II
DISCOVERY III

Included in Kit:

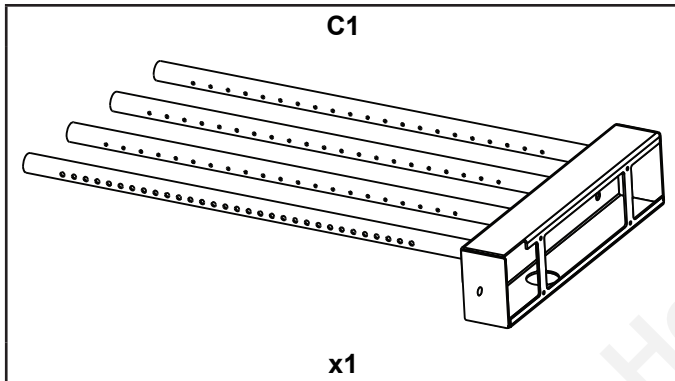

Included in kit:

Quantity one (1) Tube Channel Assembly (C1)

Tools Required:

Phillips head screwdriver and 7/16 inch socket wrench

Model	Service Kit
2100 Millennium	SRV7039-004
3100 Millennium	SRV7033-023
4300 Series	SRV7033-023
Discovery I	SRV7039-004
Discovery II	SRV7033-023
Discovery III	SRV7033-023

NOTE: Service Space

In order to replace the tube channel assembly a minimum clearance is required on the right side of the stove in order to remove the tubes with the stove in place. If space is not available, the stove will have to be disconnected from the chimney to proceed with the tube replacement.

Model	Required Space
2100	17 inches (432mm)
3100	19 inches (483mm)
4300	19 inches (483mm)

Removing Manifold Tube Channel

1. Using a Phillips head screwdriver, remove the right side shield by removing the two (2) screws in the back (Figure 1).
2. Using a Phillips head screwdriver, remove the four (4) screws from channel cover; set channel cover aside (Figure 1).
3. Using a 7/16 inch socket wrench remove the two (2) channel nuts inside of chamber (Figure 1).
4. Slide out tube channel assembly with gasket; discard both.

Replacing Manifold Tube Channel

NOTE: Gasket is installed from factory onto the Tube Channel Assembly (C1). If not installed, simply line up the wholes of the gasket with the tubes slide to base of Tube Channel Assembly (C1).

1. Validate gasket is already installed onto Tube Channel Assembly (C1).
2. Slide the Tube Channel Assembly (C1) into side of firebox and insert each tube into the corresponding holes in the tube channel rack starting with the back hole first (Figure 1).
3. Make sure Tube Channel Assembly (C1) is flush against the side of the stove and secure with two (2) channel nuts (Figure 1).
4. Re-install channel cover and side shield (Figure 1).

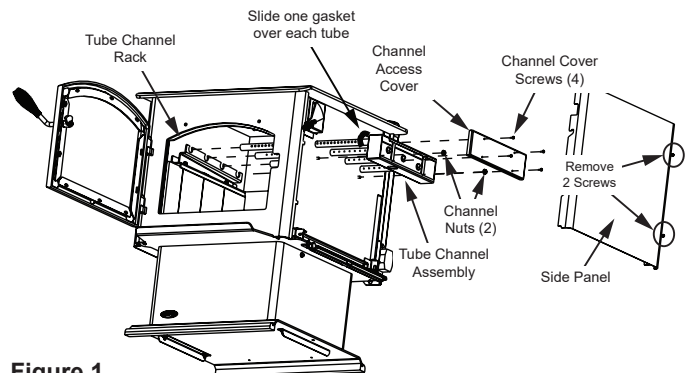

Figure 1