

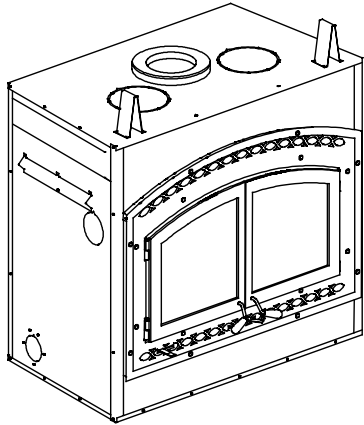

INSTALLATION AND OPERATION INSTRUCTIONS

WCT6840WS





SAVE THESE INSTRUCTIONS FOR FUTURE REFERENCE

An French manual is available upon request. Order P/N 900090-00.

Ce manuel est disponible en français, simplement en faire la demande.

Numéro de la pièce 900090-00.

	! WARNING
	<ul style="list-style-type: none">• Hot! Do not touch! The glass and surfaces of this appliance will be hot during operation and will retain heat for a while after shutting off the appliance. Severe burns may result.• Carefully supervise children in the same room as appliance.
<ul style="list-style-type: none">• If small children are present in the home, it is recommended that this appliance be fitted with an adjustable safety gate or barrier screen.	

EPA Wood-Burning Fireplace
P/N 900089-00 REV. NC 12/2013

MODEL

WCT6840WS

This installation manual will enable you to obtain a safe, efficient and dependable installation of your fireplace system. Please read and understand these instructions before beginning your installation.

Do not alter or modify the fireplace or its components under any circumstances. Any modification or alteration of the fireplace system, including but not limited to the fireplace, chimney components and accessories, may void the warranty, listings and approvals of this system and could result in an unsafe and potentially dangerous installation.

IHP wood-burning fireplaces are designed for use as a supplemental heater. They are not intended for continuous use as a primary heat source.

! WARNING

- The fireplace cannot be operated without a door or firescreen. Consult your dealer to select the correct replacement door or firescreen.
- The fireplace is equipped with a blower, electrical connection must be made prior to fireplace installation
- Important! To assure proper alignment of glass doors: Install this fireplace in a square and plumb condition, using shims as necessary at sides and/or bottom.
- Install the fireplace only as described in these instructions.



Listed to standards:
ULC-S610 and UL-127
Report No. 304-7213
EPA Cert. No. 609

NATIONAL
FIREPLACE
INSTITUTE



www.nficertified.org

We recommend that our woodburning hearth products be installed and serviced by professionals who are certified in the U.S. by the National Fireplace Institute® (NFI) as NFI Woodburning Specialists or who are certified in Canada by Wood Energy Technical Training (WETT).



IMPORTANT! GENERAL SAFETY PRECAUTIONS. READ AND UNDERSTAND THESE SAFETY RULES BEFORE YOUR FIRST FIRE.

! WARNING

The WCT6840WS fireplace must be installed with an outside air kit, which is included with fireplace.

! WARNING

THE FIREPLACE MUST BE OPERATED WITH THE DOORS FULLY OPENED OR DOORS FULLY CLOSED. IF THE DOORS ARE LEFT PARTLY OPENED, GAS AND FLAME MAY BE DRAWN OUT OF THE FIREPLACE OPENING, CREATING RISKS OF BOTH FIRE AND SMOKE. IF THE UNIT IS OPERATED WITH THE DOORS FULLY OPENED, THE FIRE SCREEN MUST BE USED.

! WARNING

NEVER use gasoline, gasoline-type lantern fuel, kerosene, charcoal lighter fluid, naphtha, engine oil or similar liquids to start or "freshen up" a fire in this fireplace. Keep any flammable liquids a safe distance from the fireplace at all times.

! WARNING

THIS FIREPLACE HAS NOT BEEN TESTED WITH AN UNVENTED GAS OR A FIREPLACE INSERT. TO REDUCE RISK OF FIRE OR INJURY, DO NOT INSTALL AN UNVENTED GAS LOG SET OR FIREPLACE INSERT OR OTHER PRODUCTS NOT SPECIFIED FOR USE WITH THIS FIREPLACE.

! WARNING

Use care when selecting window treatments for windows located near the fireplace. Avoid using combustible flowing window treatments such as curtains on nearby windows that are of sufficient length to be blown in front of an open flame when the window is opened.

Keep any combustible furniture, materials or decorative pillows at least 48" (1219 mm) from the front fireplace opening.

! WARNING

Never leave your fireplace unattended while it is burning.

! IMPORTANT

When burning wood, use SOLID NATURAL DRY WELL-SEASONED WOOD ONLY. Hardwoods are recommended (soft woods tend to burn very quickly).

- DO NOT burn treated wood, charcoal, coal, trash, cardboard, driftwood, woods dipped in tar, Christmas tree greens, pitch, pine tar, creosote, chemical chimney cleaners, flame colorants, polystyrene packaging, wood products with synthetic binders (i.e. plywood). Plywood, lumber and other misc. materials can produce abnormally high temperatures, sputtering and smoking fires and may contain hazardous chemicals to treat insects and fungus.
- Burning unapproved fuels can produce excessive temperatures, beyond the design capabilities of the fireplace and may produce excess sparks or may contain hazardous chemicals. Burning unapproved fuels can result in a chimney fire, a house fire, personal injury, death or loss of property.

! WARNING

Never leave children unattended when there is a fire burning in the fireplace.

! WARNING

To avoid the risk of damaging fireplace materials and increasing the risk of fire, do not use the fireplace to cook or warm food.

! WARNING

Be careful adding wood fuel to the fire or handling fireplace tools such as shovels, tongs or pokers.

! WARNING

Never modify or alter your fireplace system in any way. To do so may create a potential fire hazard and void the limited warranty, listings and approvals of this system.

! WARNING

The bottom refractory can be cracked by excessive abuse such as tossing heavy logs onto the grate or gouging with fireplace tools. Exercise caution when adding wood to your fireplace.

! WARNING

Neither the manufacturer nor the seller warrants "smoke free" operation nor are we responsible for inadequate system draft caused by mechanical systems, general construction conditions, inadequate chimney heights, adverse wind conditions and/or unusual environmental factors or conditions beyond our control.

! WARNING

Always ensure that the air inlet to the fireplace is free from debris and any other obstructions that can block the entrance of air.

CONGRATULATIONS!

When you purchased your new fireplace, you joined the ranks of thousands of individuals whose answer to their home heating needs reflects their concern for aesthetics, efficiency and our environment. We extend our continued support to help you achieve the maximum benefit and enjoyment available from your new fireplace.

Thank you for selecting a IHP fireplace as the answer to your home supplemental heating needs.

TABLE OF CONTENTS

Safety Rules.....	Page 2
Introduction.....	Page 3
Parts Required.....	Page 3
Optional Equipment.....	Page 3
Operating The Fireplace.....	Page 3
Fuel.....	Page 3
Combustion Control.....	Page 4
Refueling For Best Performance.....	Page 5
Smoking – Causes And Troubleshooting.....	Page 5
Important Cautions.....	Page 5
Maintaining Your Fireplace.....	Page 5
Creosote.....	Page 5
Chimney Maintenance.....	Page 6
Dealing With A Chimney Fire.....	Page 6
Door Frame Finish Care.....	Page 6
Disposing of Ashes.....	Page 6
Refractory Replacement.....	Page 6
Door Installation.....	Page 6
Door Adjustment.....	Page 6
Glass Care - Replacement.....	Page 7
Glass Care - Cleaning.....	Page 7
Gasket Replacement.....	Page 7
Fireplace Installation.....	Page 7
Locating The Fireplace.....	Page 7
Facade Installation.....	Page 9
Framing, Facing And Mantel.....	Page 9
Hearth Extension Requirements.....	Page 9
Cold Climate Installations.....	Page 9
Nailing Flanges.....	Page 11
Mantel and Facing.....	Page 11
Fireplace Blower.....	Page 12
Hot Air Ducting Installation.....	Page 12
Gravity Kit.....	Page 10
Outside Air Kit.....	Page 13
Chimney System.....	Page 14
Chimney Installation Notes.....	Page 14
Chimney Installation Instructions.....	Page 15
Offset Chimney Installation.....	Page 16
Angled Wall Radiation Shield.....	Page 19
Chimney Support Installation.....	Page 19
Chimney Chase And Multiple Terminations.....	Page 19
Masonry Application Instructions.....	Page 20
Installation Accessories.....	Page 21
Replacement Parts.....	Page 22
Specifications.....	Page 22
Clearance to Combustibles.....	Page 22
Chimney Components Lists.....	Page 23
Warranty.....	Page 25
Product Reference Information.....	Page 26

THE FIREPLACE INTRODUCTION

The WCT6840WS wood-burning fireplace is an energy efficient, heat circulating, closed combustion fireplace. You will receive a lifetime of comfort and enjoyment from your fireplace provided it is installed, maintained and operated properly.

- Please read these instructions and retain this manual for future reference.
- Before beginning the fireplace installation, consult the local authorities to obtain your building permit and check your local building codes. Install the fireplace only as described in these instructions and using only IHP components.
- This fireplace has been tested for CAN/ULC S610-M87 and ANSI/UL 127 under report number 304-7213. It has also been tested for EPA 40 C.F.R Part 60, section 60.532(b). Certificate number 609.
- The WCT6840WS fireplace is not intended for use with a gas log set. Do not use a fireplace insert or any other product with this fireplace unless it is specified by IHP for use with this appliance. Failure to follow these instructions will void the certification and the warranty of the fireplace and may result in an unsafe installation.
- These appliances are designed to provide supplemental heat to the immediate area only. Therefore, it is advisable to have an alternate heat source when installed in a dwelling.
- These appliances are not approved for Manufactured Home installations.

PARTS REQUIRED

Fireplace model: WCT6840WS

- **7" diameter chimney*** - Model Secure Temp® S-2100+, Nova Temp® HT6000+, Secure Temp GX (U.S. only) or ACBI manufactured by Security Chimneys International™ only, including:
 - Chimney lengths
 - Elbows (where necessary)
 - Associated components as per these installation instructions
- **Decorative Doors** - Required (Order Separately - See **Page 21**)
- **Front Facade kit - Required** (Order Separately - See **Page 21**)
- **UZY7 Blower** (included in the fireplace).
- **VRUW Blower Speed Control** (included)
- **Outside air kit (Included w/Fireplace)**

OPTIONAL EQUIPMENT

- AC Chimney Adaptor * (required if using AC Chimney *)
- AC Chimney Outside Air Kit
- Gravity Venting System
- Rigid Firescreen

Additional Equipment (optional)

- Forced Air Kit ❶
- Gravity Venting System
- Tubinox™* chimney (or Projet® SS*), 7" diameter with adaptor for installation in a masonry chimney.

❶ **Not tested under EPA certification. If installed, this appliance no longer qualifies for EPA certification.**

OPERATING THE WCT6840WS FIREPLACE

Fuel - USE SOLID NATURAL WOOD FUEL ONLY. The WCT6840WS fireplace is designed to work best when fueled with dry seasoned natural wood only. Hardwoods are preferred to softwoods since the energy content of wood is relative to its density. Hardwoods will result in a longer burning fire and less frequent refueling. A moisture content of 15% to 20% (seasoned) is recommended. Wood that has been cut and split and let to dry under a cover for a period of one year will usually meet that criteria. The required drying time will vary depending on the climate. Wood that is packed tight together will take longer to dry. Seasoned wood is darker in color than wet wood and will have visible cracks in the grain on the ends. Excessively wet wood will be difficult to burn and will result in lower efficiency, increased creosoting and deposits on the glass and in the chimney. Excessively dry wood will burn well but will also have higher emissions and shorter burning time.

Do not burn scrap or garbage, treated wood or wood such as driftwood from the ocean which has been exposed to salt or other chemicals. Salt or chemicals can corrode the firebox and chimney. Do not burn large amounts of paper, cardboard, Christmas tree branches or building construction materials. Intense firing with these materials may overheat the fireplace, causing damage to the unit, a fire or even possibly igniting a chimney fire if the chimney is creosoted. Burning unapproved fuel, resulting in excessive pollutants being emitted, may be prohibited and subject to a fine or other penalty by the authority having jurisdiction in your area.

Processed firelogs can be used. Use only firelogs that have been evaluated for the application of fireplace and refer to firelog warnings and caution markings on packaging prior to use.

First Fires

Before using the fireplace make sure to remove the plastic wrapping and EPA label on plated door. Remove any glue residue left by the label using mild soap.

Make sure the doors are properly adjusted, thus avoiding color change to finish due to overheating.

The first five or six fires should be small fires of short duration (about 30 to 60 minutes).

This will help cure the refractory bricks. During the first few fires of this appliance there may be some odor and smoke due to the curing of the paint, dust accumulation and burning off of lubricants used in the manufacturing process. It may set off a smoke alarm located in the same room. For this reason the room should be well ventilated for the first few fires.

HEAT OUTPUT

The WCT6840WS fireplace is the largest member of the IHP high efficiency fireplaces. The heat generated from its fire is more efficiently captured and distributed. In spite of the large amount of heat that the WCT6840WS fireplace can deliver, it should not replace the main source of heat in your home. This fireplace will bring extra warmth and ambiance to your home by distributing its heat as described further in the manual.

COMBUSTION CONTROLS

Primary Air and Air Boost Controls

There is no flue damper in the WCT6840WS fireplace. As is common with air tight appliance, the combustion air control sets the flow of air entering the firebox. This allows for a more precise control of the fire. The combustion air control is located below the door on the left side. The main source of air (primary air) entering the firebox can be diminished by moving the air combustion control from left to right. The primary air is fully opened when the

air control is completely moved to the left. This air combustion control should be in the closed position when the fireplace is not in operation. This will minimize air leakage up the chimney.

The combustion air control should be opened before opening the doors to minimize the possibility of back draft coming into the room (**Figure 1-A**) More details are available in *Refueling For Best Performance* on **Page 5**.

Time Delayed Air Boost System

The time delayed air-boost system register is located underneath the door handles. Placed in the fully opened position, a timer with a maximum duration of 2 hours is engaged.

The register gradually reduces the amount of air injected, allowing for a better start of the fire, whatever the conditions (See sections *Building a Fire* and *Refueling For Best Performance* for proper sequence of operation). This allows you to start the fire, set the primary air control to the desired burn level and the fireplace will automatically adjust itself to that level once the fire is fully established (**Figure 1-B**).

Accelerated Combustion

The maximum heat output for the WCT6840WS fireplace is achieved by burning with the door closed and the combustion air opened and pulled out. Through this method, the WCT6840WS fireplace can produce up to 80,000 BTU of heat per hour.

However, it will be necessary to reload with wood every one or two hours. This is the least efficient method of burning the WCT6840WS fireplace.

Use caution when firing with the combustion air control wide open. Only burn cord wood in this manner. Small dry pieces of softwood and construction scraps will burn very intensely using this method and may damage the firebox.

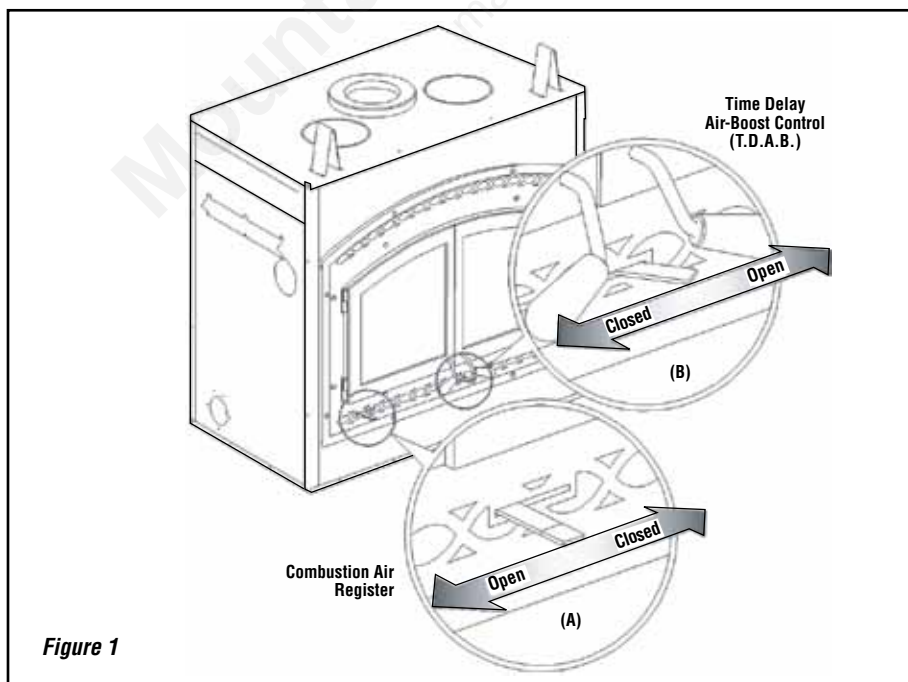

Figure 1

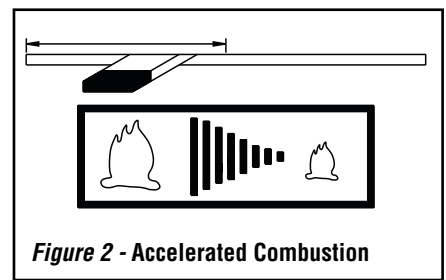

Figure 2 - Accelerated Combustion

Medium Combustion

This is the recommended mode of operating the WCT6840WS fireplace and should be the one normally used since it will deposit the least amount of creosote on the glass and in the chimney. The combustion air control must be 3/4 closed. The precise setting will depend on many factors, including chimney length and the moisture content of the wood.

For instance, a long chimney will necessitate closing the damper more. To obtain the proper combustion, close the damper completely, then open it about 1/2" to 3/4". Three medium size pieces of cord wood-burning on a bed of hot coals will generate an approximate heat output will of 35,000 BTU per hour and the loading time will be about every 3-4 hours. Softwoods may be burned using this method but the combustion time will be substantially reduced.

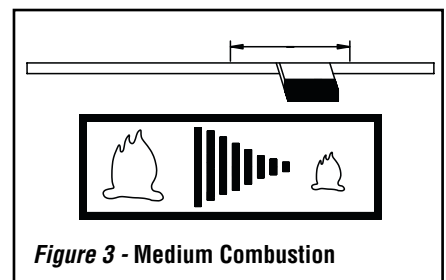

Figure 3 - Medium Combustion

Slow Combustion

When the air combustion control is completely closed, the fireplace is in a slow combustion phase. If the hearth is hot enough, slow combustion will not extinguish the fire, but there will be a noticeable change in the flame pattern. The flames will be slow and may appear dirty if the wood is too wet (moisture content of 20% and more).

Do not allow the wood to burn without flame, since this will produce excessive creosote in the unit. Creosote may accumulate on the glass door. This method of burning should be used only after operating the WCT6840WS fireplace with the air control opened to produce a hot fire for about an hour or at medium pace for at least three (3) hours. Slow combustion can be used at night in order to reduce the heat output and to prolong the burn. The loading time will be between 6-8 hours and at this combustion rate, the level of BTU's is at its lowest.

NOTE: DIAGRAMS & ILLUSTRATIONS ARE NOT TO SCALE.

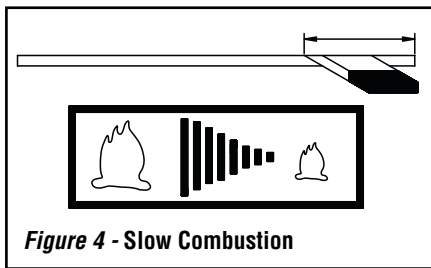

Figure 4 - Slow Combustion

Building a Fire

- To start a fire, place several crumpled up balls of newspaper in the firebox. Place small dry pieces of kindling on top of the paper, criss-crossing the kindling so that there are air spaces in between. The kindling should be placed at the center of the firebox so as to allow for sufficient air circulation.
- Adjust the primary air control and start the time delayed air-boost system by pushing the register towards the right. Light the newspaper. Leave the doors partially opened to facilitate the start-up.
- Once kindling fire is well established, cord wood can be added. You may set the primary air control to the desired level (see *Primary Air Combustion Control* and *Air Boost Controls* section for proper operation of the air controls).
- Set the primary control to the desired burn level. The fireplace will automatically go to that level after the fire is fully established and the air boost is closed.

The unit will burn best with 2-3 pieces of cord wood spaced 1 to 2 inches apart and allowing air to get under the fuel. Criss-crossing or arranging the fuel so that air can get underneath will help the fire to get started easily. The unit should be operated with the air control fully open long enough to get the cord wood well ignited.

REFUELING FOR BEST PERFORMANCE

To reload the WCT6840WS fireplace at the end of a combustion cycle, when no flame is visible and there are only ashes left:

- Completely open the air control level and the T.D.A.B. (Time Delay Air Boost) level. See **Figure 1**.
- Open the doors about 1" and wait 5 seconds until the air flow has stabilized. Then open the doors completely, put the logs in and close the doors.
- Set the air control to the desired burn level. The T.D.A.B will close by itself progressively.

To reload the WCT6840WS fireplace when the fireplace is still hot with a few visible flames:

- Open the air control completely. The T.D.A.B can be set to a lower setting in order to facilitate lighting.

- Open the doors about 1" and wait 5 seconds until the air flow has stabilized. Then open the doors completely, put the logs in and close the doors.
- Set the air control to the desired burn level.

NOTES:

- For spectacular fire and optimization of the fireplace efficiency, we recommend that the wood load be placed as far back as possible.
- It may be necessary to turn off any blower(s) in operation during the refueling process in order to minimize smoking in the room. It is recommended to wait 15 to 30 minutes before turning the blower(s) back on to ensure successful rekindling.

SMOKING – CAUSES AND TROUBLESHOOTING

To reduce the likelihood of smoke coming into the room when opening the door, set the combustion air controls to the left ("Accelerated Combustion") before opening the door. Your fireplace has been designed and tested to provide smoke free operation.

As the fire burns, air goes up the chimney. This air must be replaced through the outside air duct. When operating the WCT6840WS fireplace, open a nearby window temporarily to check if there is adequate replacement air supply. Occasionally, there may be a small amount of smoking upon lighting the fire, until the chimney heats up but this should not last. If the fireplace continues to smoke it is probably for one of the following reasons:

- The doors are partially opened** - When you open the doors, open them completely.
- Negative pressure in the house** - As the fire burns, air goes up the chimney. This air must be replaced through leakage into the house or through the outside air duct (optional). When operating the fireplace, open a nearby window temporarily to check if there is adequate replacement air supply.
- Fans operating (e.g.: range hood)** - These fans draw air out of the house and may actually cause a negative pressure in the house. Turn off all fans and open a nearby window to determine if this is the cause of the problem.
- Wetwood** - Wet or tarred wood will smoulder and smoke instead of burning properly. Your dealer can help you determine if you have properly seasoned wood for burning.
- Dirty or blocked chimney** - Check to make sure the chimney is clear and clean. If dirty call a certified chimney sweep or use a properly sized chimney brush to clean.
- Chimney not long enough** - The minimum chimney height is 12 feet not including the fireplace height. The chimney must extend at least three (3) feet (915 mm) above its point of contact with the roof and at least two (2) feet (610 mm) higher than any roof or wall within ten (10) feet (3 m) of it. When installed with offsets, the minimum chimney height is 15 feet. Additional height will increase draft and will decrease the tendency to smoke.

G. Poor chimney draft

With no fire, there should be sufficient draft to exhaust cigarette smoke introduced under the baffle. Chimneys installed against an outside wall without protection may generate back draft problems which will cause start-up problems. To prevent this, open a nearby window; roll up a piece of paper, light it and hold it in the upper part of the firebox to warm up the chimney. Wait until the draft is sufficient, then start the fire.

- Blower for forced air kit operating** - Make sure that the blower is at the "off" position when you open the fireplace door for reloading.

IMPORTANT CAUTIONS

- Do not block the hot air vents to the fireplace as this will cause the fireplace to overheat.**
- Never use gasoline, gasoline-type lantern fuel, kerosene, charcoal lighter fluid, or similar liquids to start or 'freshen up' a fire in this fireplace. Keep all such liquids well away from the fireplace while it is in use.**
- Do not burn coal. The sulphur in coal will corrode the firebox and chimney.**
- Do not burn driftwood which has been in the ocean or salt water. The salt will corrode the firebox and chimney.**
- Do not burn wood in the area in front of the grate.**
- Do not abuse the unit by burning paper, or cardboard or construction material such as pressed wood, plywood or lumber. Wood protectors, metallic paper, coal, plastic, waste, sulphur and/or oil will damage the fireplace.**
- Do not allow the wood to smoulder or burn without flame, since this will produce excessive creosote in the unit as well as increased particulate emissions.**

MAINTAINING YOUR WCT6840WS FIREPLACE

Creosote - Formation and Need for Removal
When wood is burned slowly, it produces tar and other organic vapors, which combine with expelled moisture to form creosote. The creosote vapors condense in the relatively cool chimney flue of a slow-burning fire. As a result, creosote residue accumulates on the flue lining. When ignited this creosote makes an extremely hot fire.

The chimney shall be inspected at least twice a year during the heating season to determine when a creosote buildup has occurred.

When creosote has accumulated it shall be removed to reduce the risk of a chimney fire.

When the creosote accumulation is large, a creosote fire in the chimney can damage the chimney and overheat the surrounding wood framing. Creosote formation in a chimney can be minimized by making sure there is always visible flame burning, avoid smouldering fires and by proper refuelling techniques.

Chimney Maintenance

Regular chimney inspection and maintenance combined with proper operation will prevent chimney fires. Keep your chimney clean. Do not allow more than 1/16" (1.6 mm) creosote build up in your chimney. The amount of creosote will depend on variables such as frequency of use and type of fire. We recommend that you:

- A. Initially inspect the chimney system weekly. From this, you will learn how often it will be necessary to clean your chimney.
- B. Have your chimney cleaned by a qualified chimney sweep. If you wish to clean it yourself, we recommend using a stiff plastic or non-metallic brush. If a metal brush is used, its size should be slightly smaller than the flue to avoid damaging the chimney. Do not use a brush that will scratch the stainless steel interior of the chimney.
- C. Do not expect chemical cleaners to keep your chimney clean. The rain cap can be removed for inspection and/or cleaning of the chimney.

Caution: It is necessary to remove the deflector from the top of the firebox before cleaning the chimney.

Dealing With a Chimney Fire

Regular chimney maintenance and inspection can prevent chimney fires. If you have a chimney fire, follow these steps:

1. **IMPORTANT:** Close the fireplace door and the combustion air controls; this will stifle the fire.
2. Alert your family of the possible danger.
3. If you require assistance, alert your fire department.
4. If possible, use a dry chemical fire extinguisher, baking soda or sand to control the fire. Do not use water as it may cause a dangerous steam explosion.
5. Ensure that sparks and hot embers coming out of the chimney are not igniting the roof.
6. Do not use the fireplace again until your chimney and fireplace have been inspected by a qualified chimney sweep or a fire department inspector.

Door Frame Finish Care

Use a glass cleaner and a soft cloth to polish the casing. Do not use abrasives such as steel wool, steel pads or an abrasive polish for they may scratch the frame's finish.

DISPOSING OF ASHES

Remove ashes only when the fire is out and the ashes are cold (24 to 48 hours after the fire is out).

Do not leave the ashes in the house as they give off carbon monoxide and other toxic gases.

! WARNING

Disposal of Ashes: Ashes should be placed in a metal container with a tight fitting lid. The closed container of ashes should be placed on a non-combustible floor or on the ground well away from all combustible materials, pending final disposal. If the ashes are disposed of by burial in soil or otherwise locally dispersed, they should be retained in the closed container until all cinders have thoroughly cooled.

REFRACTORY REPLACEMENT

The intense heat of the fire will normally cause hairline cracks in the refractory brick. These cracks can be minimized by proper curing as described in section *First Fires*. They will not normally diminish the effectiveness of the refractory brick. If large cracks develop, then the refractory should be replaced. To replace the refractory bricks, follow these steps:

1. Remove the side refractory brackets (6)
2. Remove the front refractory bricks (3)
3. Remove the bottom refractory brick (4)
4. Remove the left side refractory bricks (5)
5. Remove the right side refractory bricks (2)
6. Remove the back refractory brick (1)
7. Remove the deflectors (7) above the tubes (Can be removed without removing other bricks for chimney cleaning)

To install the new refractory bricks, follow the above steps in reverse.

DOOR INSTALLATION

The doors must be put in place only when the installation of the WCT6840WS fireplace is completed. All you have to do is fit the male part of the hinge, already on the door, to the female part, which is on the fireplace. To remove the doors, simply pull them up from the hinges. The door adjustment has been set at the factory. If the fit is still not perfect, you can adjust the door using the hinge screws (See *Figure 7-1*)

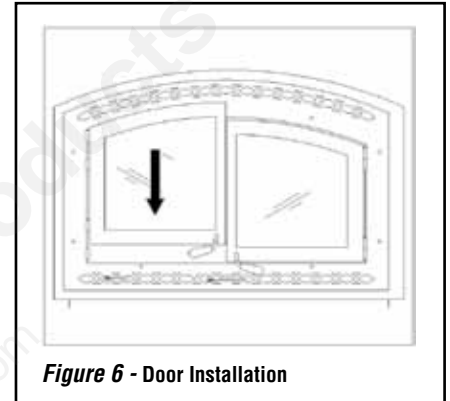

Figure 6 - Door Installation

DOOR ADJUSTMENT

The doors may need to be adjusted to be completely airtight. The gaskets' air-tightness can be adjusted using the adjustment screw located on the right side of the fireplace facade (An Allen key #1/8 – not supplied – will be necessary for this adjustment) (see *Figure 7-2*).

Checking Door Seal

A one-inch strip of paper may be used to perform a test of the integrity of the door seal. Close the door on the paper in at least eight points. It is normal to feel only a slight amount of friction. The door gasket does not need to be "tight" in all areas, since a small amount of leakage is not hazardous or detrimental to the performance of your fireplace.

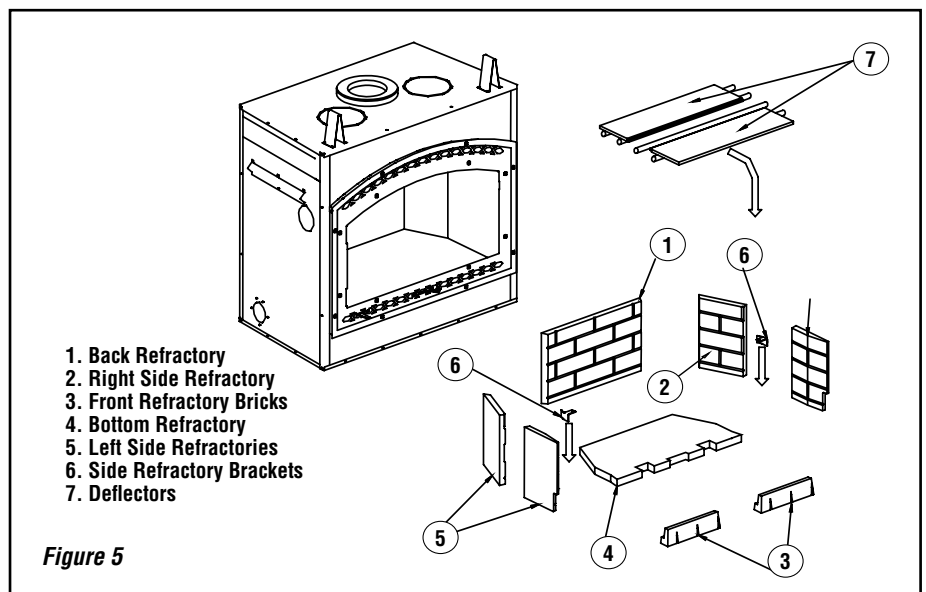

Figure 5

NOTE: DIAGRAMS & ILLUSTRATIONS ARE NOT TO SCALE.

⚠ WARNING

- Use only a IHP glass doors, specifically designed for the WCT6840WS fireplace.
- The fireplace cannot be operated without door or firescreen. Consult your dealer to select the correct replacement door or firescreen.
- Important! To assure proper alignment of glass doors: Install this fireplace in a square and plumb condition, using shims as necessary at sides and/or bottom.

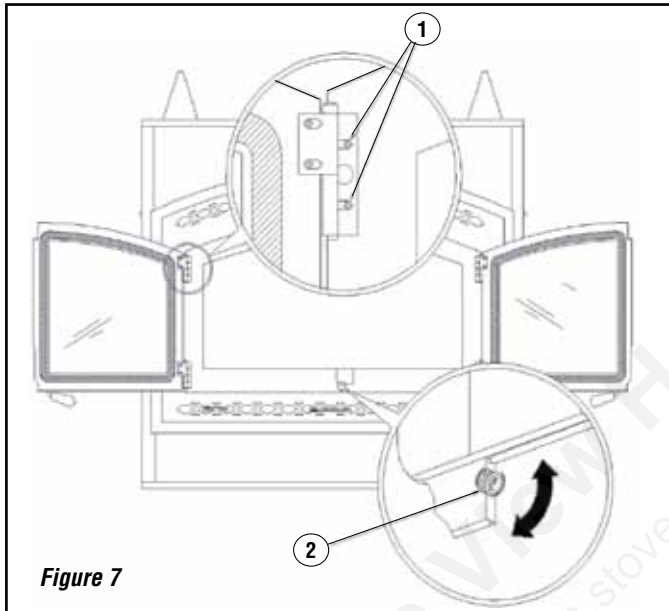

Figure 7

GLASS CARE

Glass Replacement

The glass used for the WCT6840WS fireplace is a high temperature ceramic glass (1,400° F). If the glass breaks or cracks, it must be replaced with an identical ceramic glass. Tempered glass or ordinary glass will not withstand the high temperatures of the WCT6840WS fireplace. Replacement glass should be purchased from a IHP dealer (see "Replacement Parts" on [Page 22](#)).

DO NOT OPERATE THE UNIT WITH CRACKED OR BROKEN GLASS.

Glass Cleaning

The WCT6840WS fireplace is designed to keep the glass clean under normal operating conditions. If the WCT6840WS fireplace is operated continuously with the combustion air controls closed, the glass will tend to get dirty unless the fuel, firebox and glass are maintained at hot temperatures (see section *Refueling For Best Performance*). To clean the glass, there are a number of specially designed cleaners to remove creosote. Your IHP Dealer can recommend a suitable cleaner. Regular household glass cleaners will not clean creosote. **Do not use abrasives such as steel pads, steel wool or oven cleaner as they will scratch the glass.**

DO NOT USE CHEMICAL GLASS CLEANERS ON PAINTED SURFACES AS IT MAY CAUSE THE PAINT TO PEEL.

CAUTION : DO NOT ALLOW WINDOW CLEANER TO GET IN CONTACT WITH DOOR GASKET OR PAINT ON FACADE OR DOOR. ONCE CLOSED, CONTACT OF GLASS CLEANER WITH THE FIREPLACE FACADE CAN PROVOKE PAINT PEELING OFF.

Gasket Replacement

Remove the doors from the unit (see section *Door Installation*) and lay them on a clean nonabrasive surface. To replace the gasket, first remove all of the old gasket and gasket cement. Make sure that the surface is totally clean before applying new cement (a high temperature silicone caulking rated at 500° F (260° C), is suitable) or adhesion problems may result. Apply gasket cement to the gasket channel and install the new gasket. This replacement part is available from your IHP Dealer in the following dimensions:

Gasket	Part #	Length	Qty	Dimensions
Around the glass	PR-SR1685C	61-3/4" (1569 mm)	2	1" width x 3/16" thick (26 mm x 5 mm)
On the door frame	PR-SR1823I	48-3/8" (1229 mm)	2	3/4" diameter (19 mm)
Between the doors	PR-SR1823J	17-5/8" (448 mm)	2	5/8" diameter (16 mm)

Table 1

FIREPLACE INSTALLATION

Locating The WCT6840WS Fireplace

The best location to install your fireplace is determined by considering the location of windows, doors, and the traffic flow in the room where the fireplace is located, allowing space in front of the unit for the hearth extension and the mantel, and taking into consideration the location of the hot air ducts (optional), outside air kit and chimney. If possible, you should choose a location where the chimney will pass through the house without cutting floor or roof joists (see fireplace dimensions on [Page 10](#)).

Usually, no additional floor support is needed for the fireplace. The adequacy of the floor can be checked by first estimating the weight of the fireplace system. Weights are given in the appendix. Next, measure the area occupied by the fireplace. Note the floor construction and consult your local building code to determine if additional support is needed.

The WCT6840WS fireplace may be installed directly on the floor or on a raised base and a minimum of 80" measured from the base of the appliance to the ceiling is required.

When selecting the location, the chimney outlet position and the direction of the wind are important factors affecting the chimney performance. To allow a maximum draft and to reduce wind turbulence, the chimney must:

- Penetrate the highest part of the roof.
- Be installed as far as possible from roof offsets, trees or any other obstructions that may cause wind turbulence and back drafts in the chimney.
- The least amount of offsets (elbows) possible. **NOTE:** A maximum of 2 offsets is allowed.

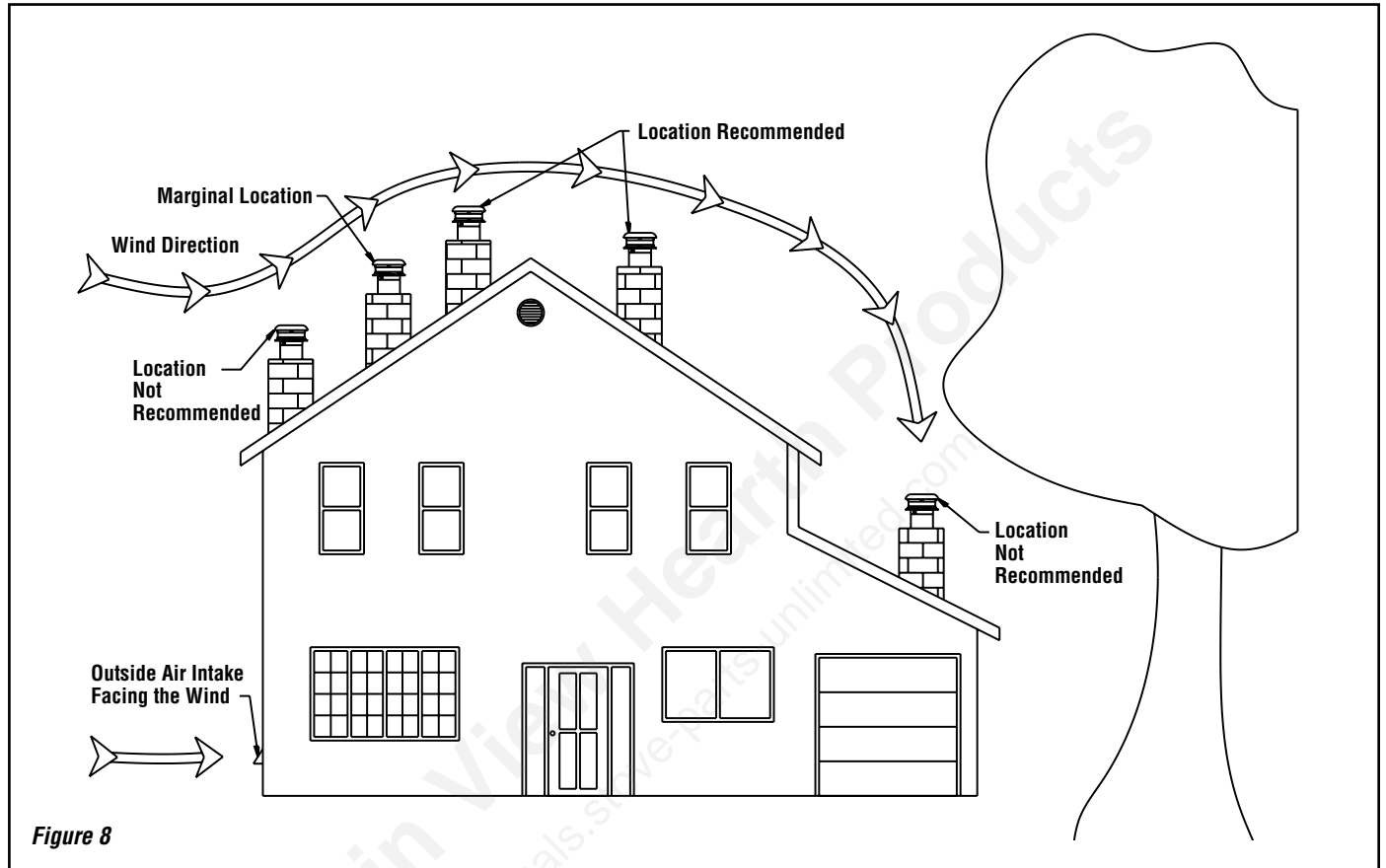

Figure 8

Facade Installation

Install the Facade per instructions provided in Facade Kit (ordered separately - see **Page 21**).

Framing, Facing And Mantel

The construction of the framing, facing, and mantel must be in accordance with the standards and the following illustrations (**Figures 10 and 11**):

- A. Frame the fireplace using 2" x 3" or heavier lumber.
- B. **WARNING: Combustible materials cannot be used in the space directly above the fireplace, except for the studs above the facade that support the facing and mantel. This area must remain empty for a height of 80" (2,032 mm) measured from the base of the appliance.**
- C. Frame the fireplace with vertical studs at the sides of the fireplace running from floor to ceiling (see **Figure 10**). If combustible facing is to be used, position the studs back, from the front edge of the fireplace (a space that is the thickness of the facing material, so that the facing can be installed flush with the fireplace facing). Frame headers between the vertical studs only as follows:
 - Place 2" x 3" or 2" x 4" headers, only along the upper part of the front, side and back faces (some codes may require a 2" x 6" on an outside bearing wall). Do not put wood or any combustible material within the area above the fireplace except on the front facing.
 - Place headers only as required to support the facing and mantel.
- D. **WARNING: The fireplace must not be in contact with any insulation or loose filling material. Cover the insulation with Drywall panels around the fireplace.**

Hearth Extension Requirements

The WCT6840WS fireplace may be installed directly on a combustible floor. The supplied safety metal strip must be positioned as follows: One half under the front of the fireplace and the other half must extend on the floor over which the hearth extension will be built (see **Figure 9a**).

- * The safety metal strip must cover the entire width of the fireplace

The combustible floor in front of the fireplace must be covered with a non-combustible material (tile, marble, stone, etc). See **Figure 9b**.

COLD CLIMATE INSTALLATIONS

Climates where temperatures will fall below 0°C (32°F).

The heating performance of the appliance will vary depending upon the level of insulation, house design, how the appliance is operated, etc.

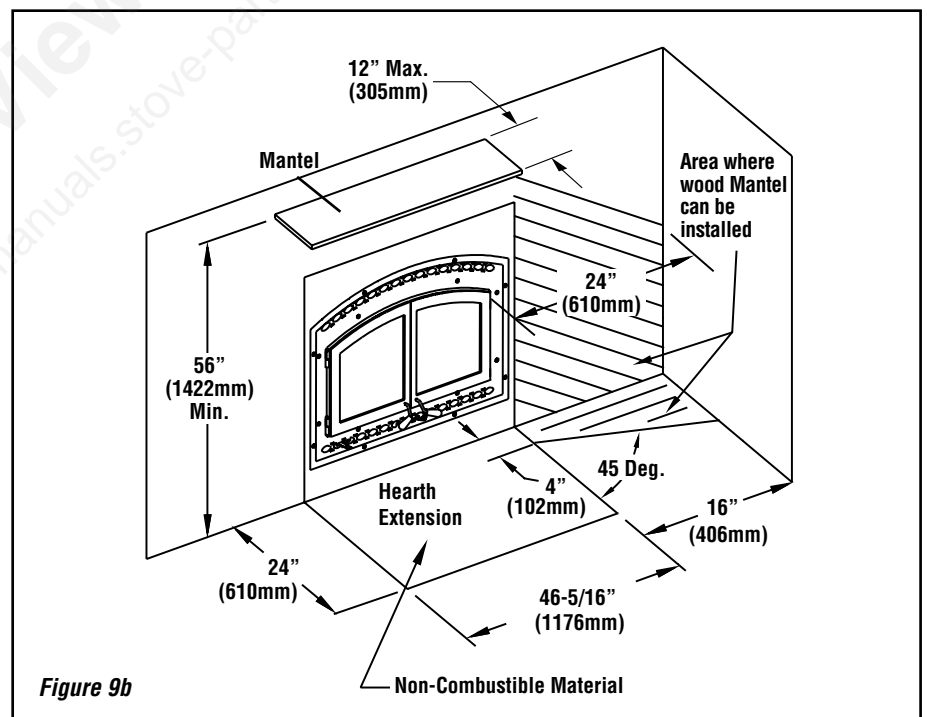
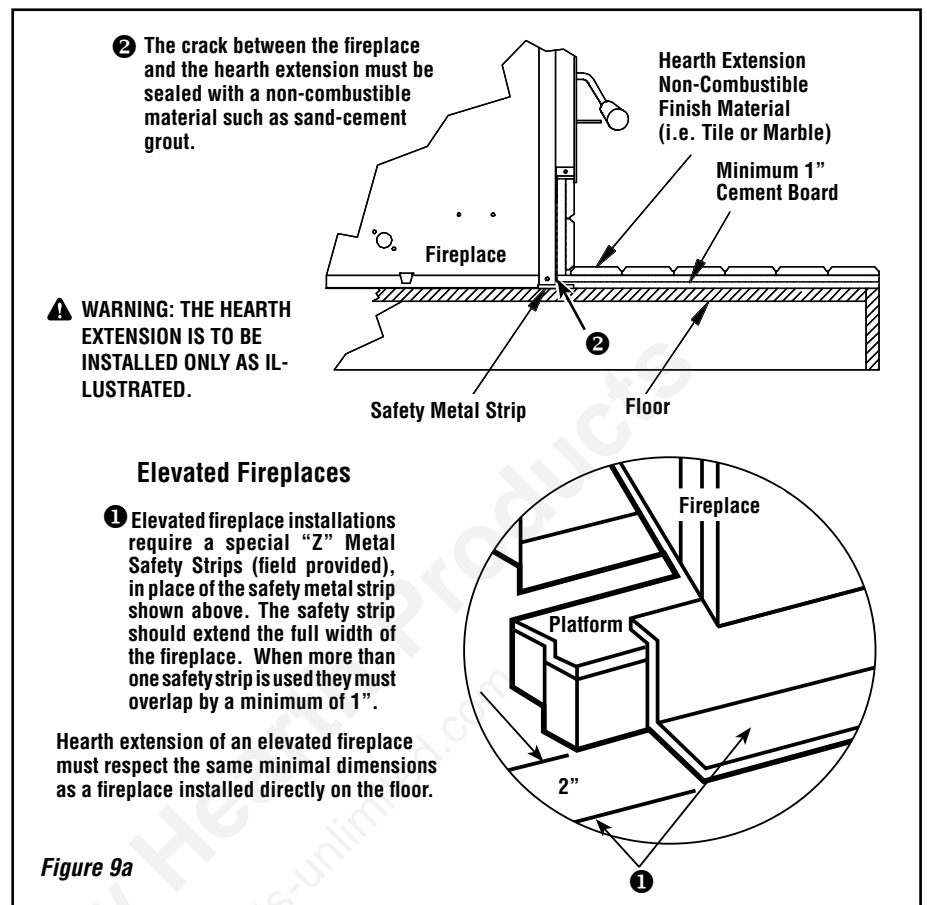

If this fireplace is being installed in a cold climate, it is especially important to seal all cracks around the fireplace and wherever cold air could enter the room with noncombustible material. Also, the outside air inlet duct should be wrapped with noncombustible insulation to minimize the formation of condensation. Do not place insulation materials directly against the chimney sections. We recommend that you use the insulated wall radiation shield since it will maintain the home's thermal barrier. AC chimney is NOT recommended in very cold climates (in areas with temperatures below 0°C (32°F)).

NOTE: DIAGRAMS & ILLUSTRATIONS ARE NOT TO SCALE.

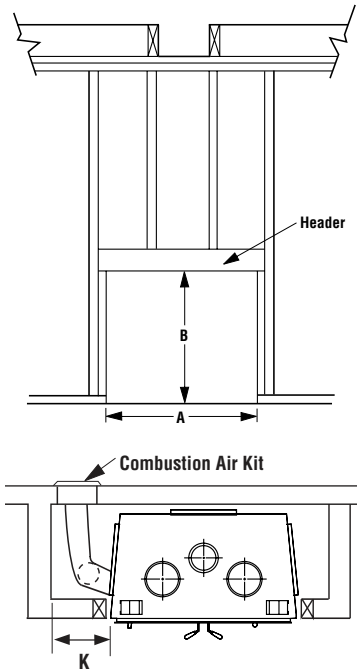

Combustible materials can NOT be used in the space directly above the fireplace. Do not fill the space above the fireplace with any material (Except the wood framing)

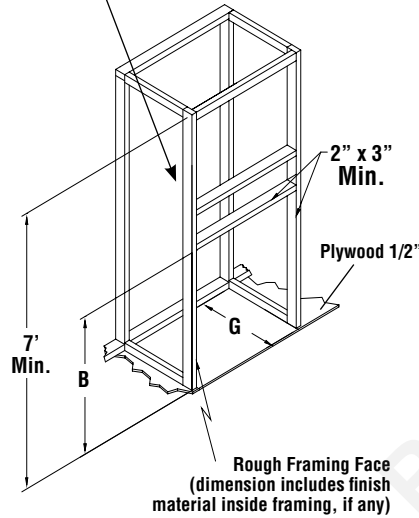

* Total depth is 25 inches including the back spacer minus 1/2 inch for drywall to be flush with the facing.

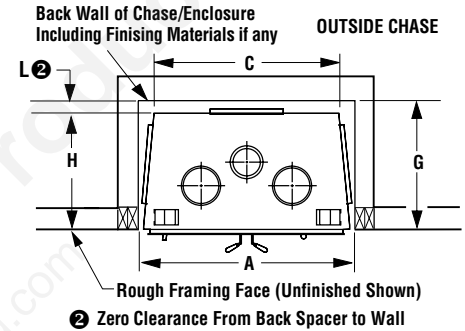
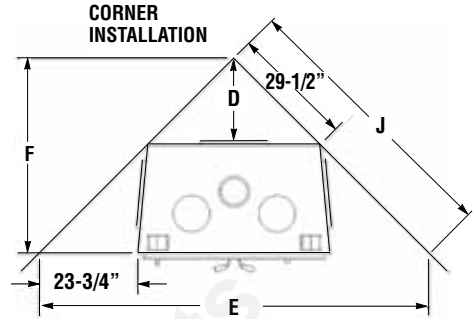

FRAMING DIMENSIONS Fireplace Opening Width		
A ①	46-1/4"	1175 mm
B	49-3/8"	1254 mm
C	42-3/4"	1086 mm
D	20-7/8"	530 mm
E	93-7/8"	2384 mm
F	47"	1194 mm
G	27-3/4"	705 mm
H	26-3/4"	680 mm
J	66-3/8"	1686 mm
K	8"	203 mm
L	1"	25 mm

NOTES
Diagrams, illustrations and photographs are not to scale – consult installation instructions. Product designs, materials, dimensions, specifications, colors and prices are subject to change or discontinuance without notice.
All framing dimensions calculated for 1/2" dry wall at the fireplace face. If sheathing the chase or finishing with other thickness materials, calculations will need to be made.
* The fireplace must not be in contact with any insulation or loose filling material. Cover the insulation with Drywall panels around the fireplace.

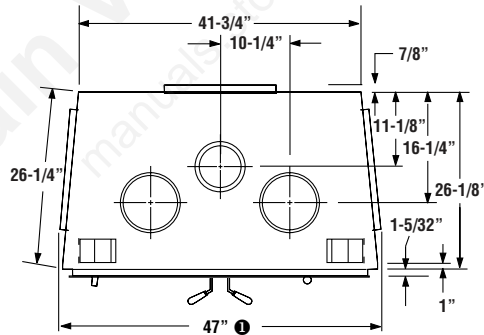

① The front framing width (A=46-1/4") will need to be 47" before pushing the fireplace into framing.

FACING

! IMPORTANT

The facade must be removable once installed. The facade is designed to overlap any facing material installed on the front of the fireplace. If thicker material is installed, use the facade as a template and make sure it can be easily removed for servicing.

1. Combustible material must be installed flush with the fireplace. It may not project in front of and on the fireplace (i.e. the steel facade of the fireplace) (Figure 14).
2. Non-combustible materials such as brick, stone or ceramic tile may project in front of and onto the fireplace facing (Figure 12).

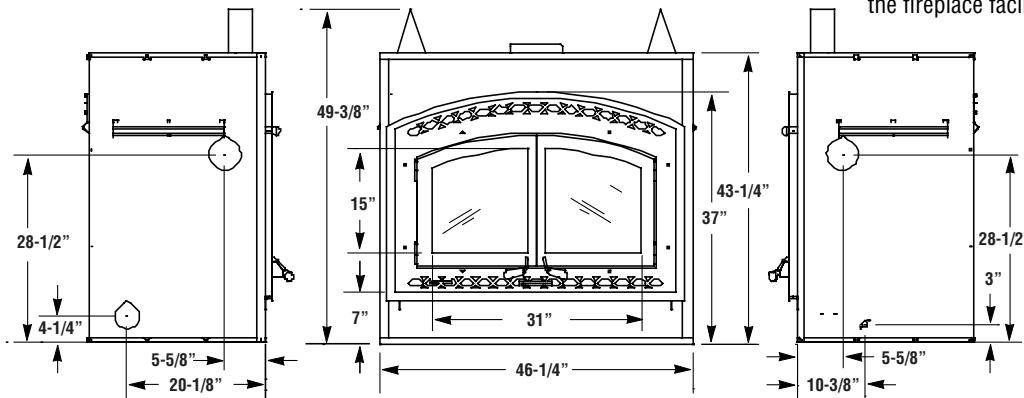
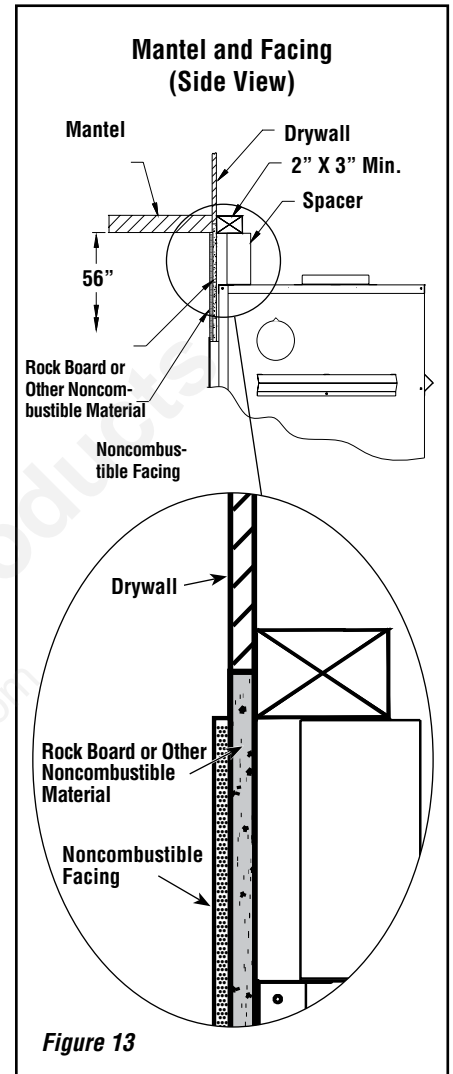
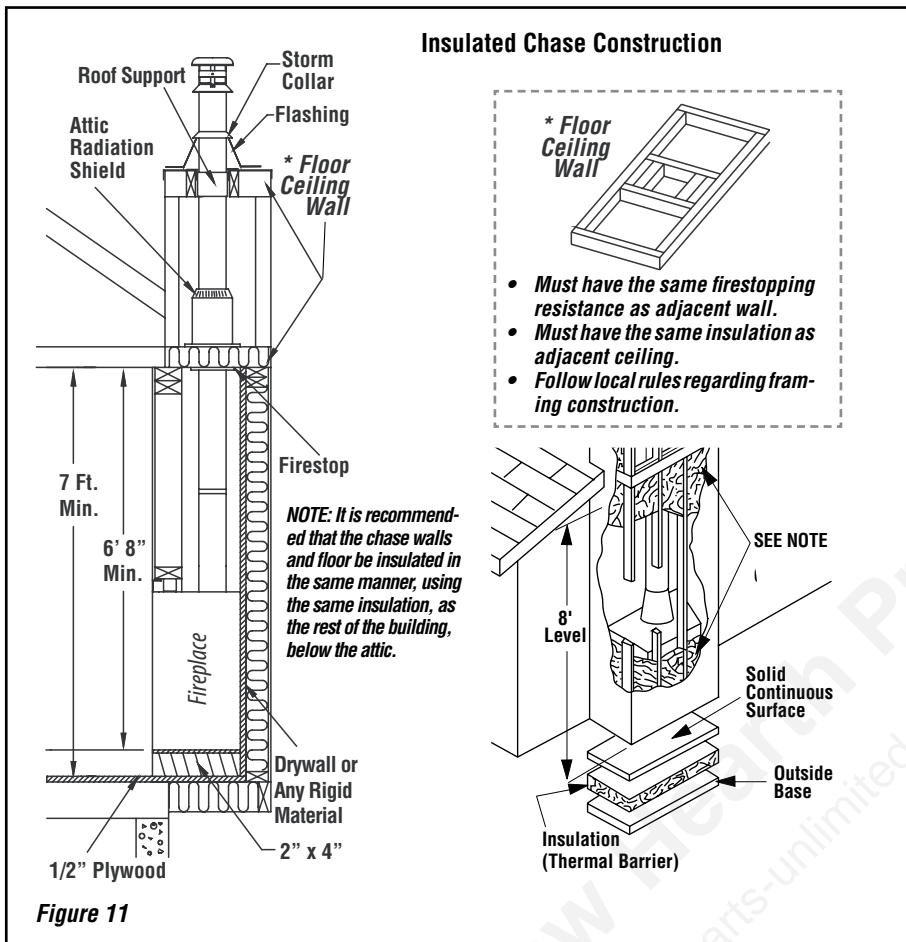
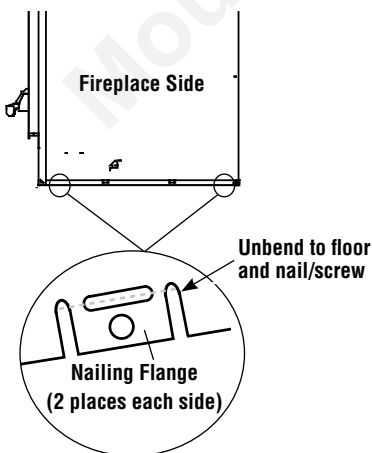

Figure 10



Nailing Flanges

Four nailing flanges are provided to secure the fireplace to the floor (see figure below). Bend the nailing flanges down so that each flange is flush with the floor, then using nails or screws, secure the fireplace to the floor (2 places each side). The heads of the screws or nails must be large enough to completely cover the holes in the nailing flanges.



MANTEL and FACING

The mantel must be installed at least 56" (1143 mm) above the base of the fireplace (Figure 13).

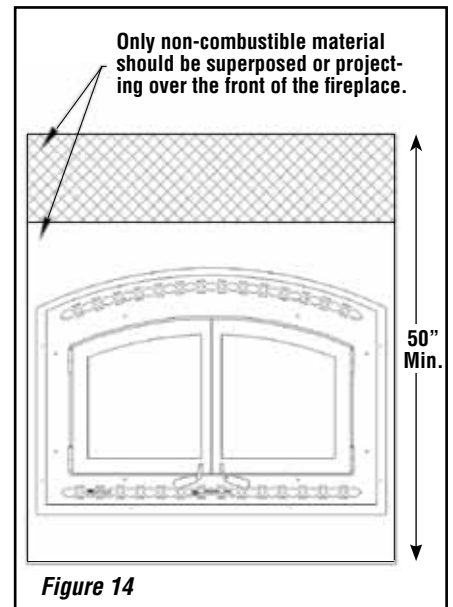
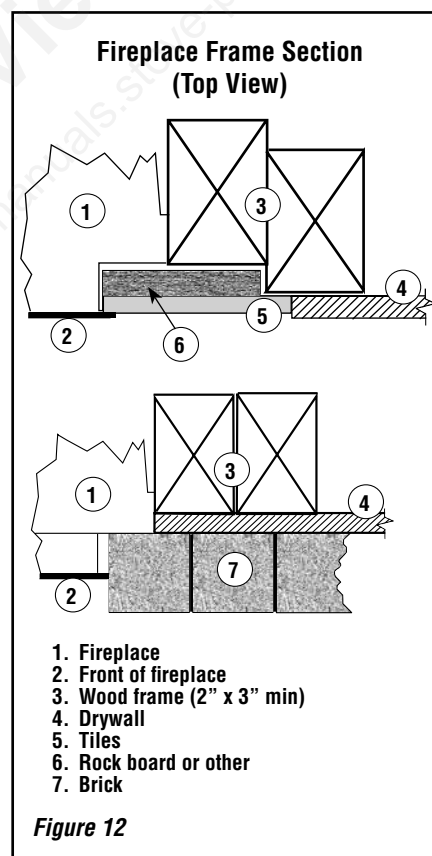

Fireplace Blower

The fireplace comes equipped with a heat activated blower. It is located in the bottom of the fireplace, towards the back. It uses 120 V and must be connected to the main electrical circuit by a qualified electrician. For connection, use the electrical box supplied with the unit located on the bottom right corner of the fireplace.

If you wish to adjust the blower speed, the variable speed control (VRUW) provided must be installed in line with the wiring. Again, use a qualified electrician for installation.

If the blower requires servicing,

- 1- Remove the doors and decorative facade.
- 2- Remove the screw located below the blower motor that holds it to the back of fireplace.
- 3- Pull the blower out of the unit through the square hole located in the front bottom right corner.

HOT AIR DUCTING INSTALLATION

The WCT6840WS fireplace is approved for use with a Gravity Kit:

Gravity Kit

The gravity kit is designed for double hot air outlets and includes:
(See **Figure 15**)

- 2 telescopic lengths 8" I.D.
- 2 90° elbows 8" I.D.
- 2 hot air outlet kits (grill and frames)
- 2 adaptors

See *Gravity Kit Accessories* on **Page 21**.

Only the blower available with the fireplace can be used with the gravity kit. For safe installation, the gravity kit must meet the following requirements:

Minimum height* 68" (1,727 mm)

Maximum length See **Figure 16**

* The height of the louver must be measured from the base of the WCT6840WS fireplace to the middle point of the louver.

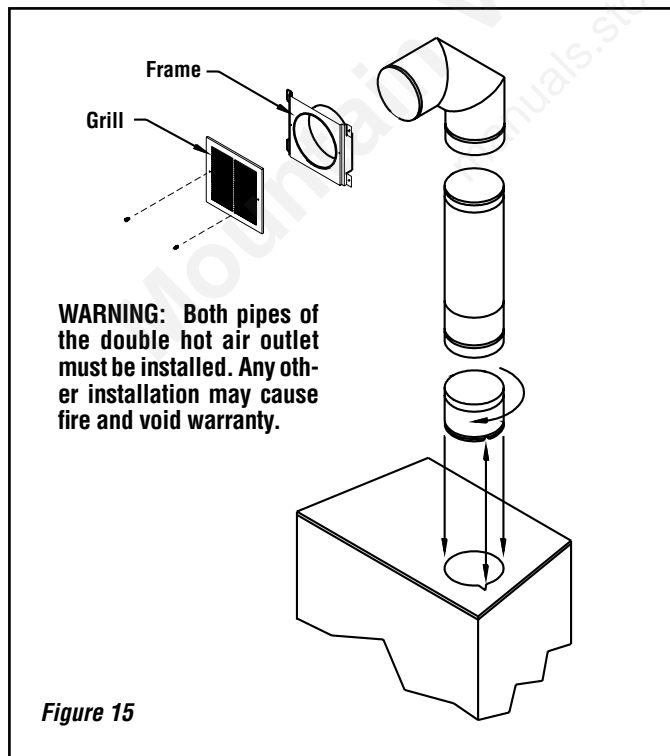

When installing the double outlet system, the hot air outlets can be installed in the same room as the fireplace, or one or both of the outlets can be installed in adjacent or upper rooms. Installing the ducts at different elevations will tend to exhaust more heat out of the higher outlet (**Figure 16**).

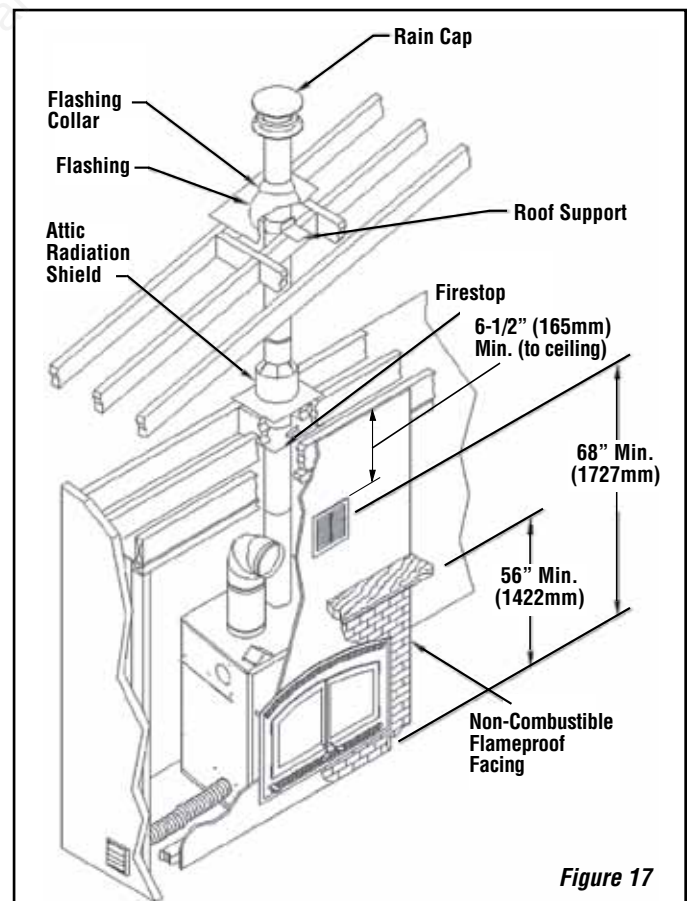
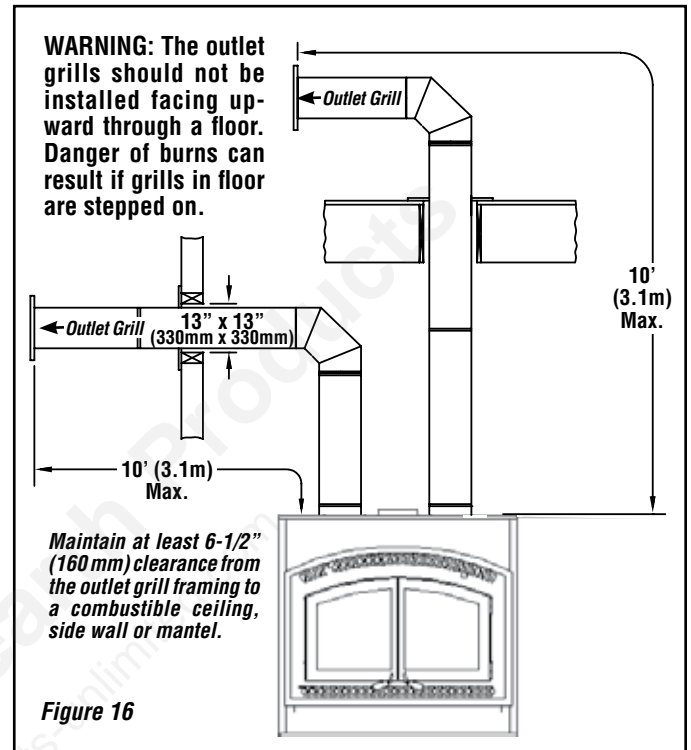

The duct system must be installed respecting the following:

1. Remove the plates closing up the 8" diameter holes on top of the fireplace. Then, cut the insulation in order to obtain two 8" dia. openings. Fix the adaptors on the fireplace openings by turning clockwise (**Figure 15**).
2. Maintain at least a 2" (50 mm) clearance between the ducts and any combustible material; the required hole size is 13" x 13" (330 mm x 330 mm).
Exception #1: For the grills, the framing can be 10-3/4" x 10-3/4" (275 mm x 275 mm) to provide the clearance as required by the integral spacers on the double outlet duct system.
3. The maximum number of elbows in a run of duct is two.
4. Maintain at least 6-1/2" (160 mm) clearance from the outlet grill framing to a combustible ceiling, side wall or mantel.
5. When traversing a combustible wall or floor, a firestop must be installed at the wall or floor penetration. The hole size must be 13" x 13" (330 mm x 330 mm)
6. Do not connect the hot air ducts to a central heating system. Malfunction of the heating system's blower will cause the fireplace to overheat. A furnace duct is only single wall and not double wall as is required for the WCT6840WS fireplace hot air exhaust.
7. Use only IHP grills and components as described in this manual. Other grills or registers may be too restrictive and may overheat the fireplace or ceiling.
8. Do not use insulated flexible ducts as they will overheat.
9. Do not use tees or any other components than the ones specifically listed here.
10. Never allow the ducting to pitch down as hot air will be trapped creating a fire hazard. Never route the ducting downwards.
11. The hot air outlet grills must be installed with the louvers pointing downwards in order to prevent overheating adjacent ceilings.

OUTSIDE AIR KIT

It is mandatory to install an outside air connection to the WCT6840WS fireplace. The following components are required and are included with the fireplace:

- Outside air kit (includes 4 inch flex that goes up to ten (10) feet long)
- 4" Adaptor for fireplace connection

Outside Air Installation

The outside air assembly may be installed according to the following requirements:

- A) Duct length should be kept to a minimum. The maximum length of a 4" interior diameter (100 mm) insulated flexible duct is 20 feet (6.1 m). The duct can be extended to a maximum of 40 feet (12 m) using a 6" interior diameter (150 mm) insulated flexible duct (See note below).
- B) The air intake register must not be installed more than ten (10) feet (3050 mm) above the base of the fireplace.
- C) The fresh air must come from outside the house. The air intake must not draw air from the attic, basement or garage.
- D) The air intake should be installed where it is not likely to be blocked by snow or exposed to extreme wind and away from automobile exhaust fumes, gas meters and other vents.
- E) The duct and register may be installed above or below floor level.

NOTE: We recommend not to exceed 20 feet of 4" flexible pipe. If you require a longer length we recommend that you use a 5" diameter flexible pipe for the complete run up to 30 feet and a 6" diameter pipe for a run of up to 40 feet.

Make a 4-1/4" (110 mm) hole in the outside wall of the house at the chosen location. From outside, place the outside air register in the hole (open side down) and fasten the register to the wall with screws as shown (see **Figure 18**). Slip the pipe into the insulated sleeve. Place the insulated pipe over the register tube and over the fireplace's outside air connector (see **Figure 19**). At each end, carefully pull back the insulation and plastic cover exposing the flexible pipe. Using the aluminium tape provided, wrap the tape around the joint between the flexible pipe and the air inlets. Carefully push the insulation and plastic cover back over the pipe. Using aluminium tape, fasten the plastic cover in place.

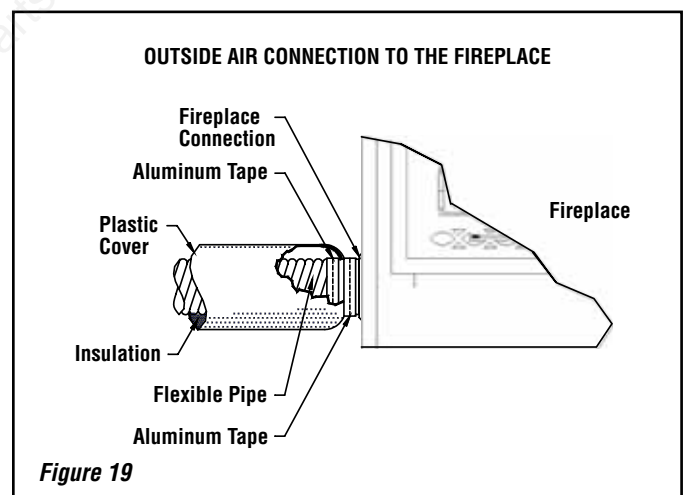
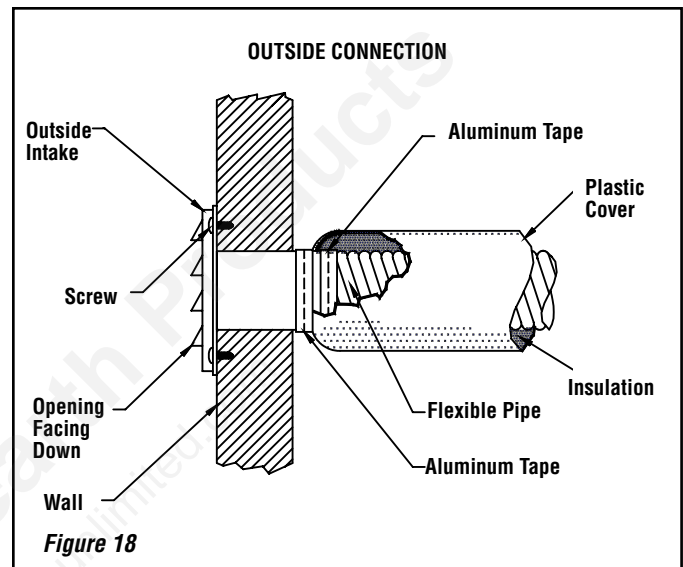

THE CHIMNEY SYSTEM

Chimney Installation Notes

1. If possible, install an interior chimney as it will provide better performance. In areas with continuous temperatures below 0°F (-18°C), the use of an exterior chimney increases the likelihood of operating problems such as low draft, high rate of creosoting, and poor start-up characteristics. Exterior chimneys are also prone to down-drafting and flow reversal. Installations which are located on lower floors in the house, such as in a basement, in combination with an outside chimney, are especially prone to flow reversal.
2. The fireplace model WCT6840WS may be installed only with Security Chimneys International Ltd 7" diameter chimney systems model Secure Temp® S2100+* / Nova Temp® HT6000* / Secure Temp GX* (U.S. only) or ACBI*.
3. A chimney venting a fireplace shall not vent any other appliance.
4. The minimum chimney height is 12 feet (3.7 m) excluding the fireplace.
5. All chimney installations must include at least one support in order to be able to take any lateral load. The maximum chimney length that can be supported by the fireplace is nine (9) feet (2.75 m) for Secure Temp S2100+* / Nova Temp HT6000+* / Secure Temp GX* and 26 feet (8m) for ACBI chimney. In altitude, add 18" (450 mm) to the chimney for every 2,000 feet (600 m) above sea level.
6. The chimney must extend at least three (3) feet (915 mm) above its point of contact with the roof and at least two (2) feet (610 mm) higher than any wall, roof or building within ten (10) feet (3 m) of it (**Figure 20**).
7. If the chimney extends higher than five (5) feet (1,500 mm) above its point of contact with the roof, it must be secured using a roof brace.
8. A rain cap must be installed on top of the chimney. Failure to install a rain cap may cause corrosion problems.
9. Cut and frame square holes in all floors, ceilings, and roof that the chimney will go through to provide a 2" (51mm) clearance between the chimney and any combustible materials. At the point of penetration through the floors, ceilings or roof, a 1" (25mm) clearance is acceptable **for AC chimney* only** (see **Table 2**). Do not fill the required clearance spaces with insulation or any other combustible material.
10. Portions of the chimney which may extend through accessible spaces must be enclosed to avoid contact with combustible materials or damage to the chimney.
11. When offsets are used, the pipe may not penetrate a ceiling or floor unless it is running vertical (no 30° offsets).

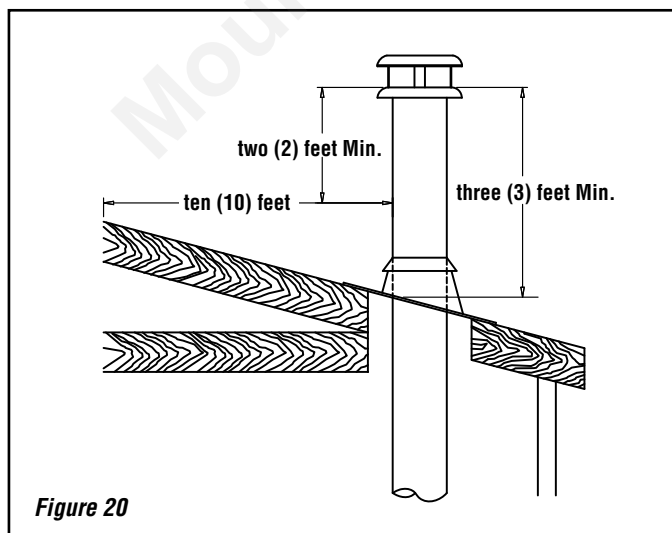

Figure 20

NOTE: 2" clearance to combustibles around chimney components required.

NOTE: Blown or fill type insulation materials must not be in contact with the fireplace or in the enclosure frame as described in "Enclosure" section.

NOTE: Local codes may not require firestopping at the ceiling levels for outside chase installations. However, it is recommended for safety and the reduction of heat loss.

CHIMNEY INSTALLATION INSTRUCTIONS

1. Cut and frame the holes in the ceiling, floor and roof where the chimney will pass (see **Figure 21**). Use a plumb-bob to line up the center of the holes. The sizes are indicated in **Table 2** for the floor and ceiling holes and **Table 3 (Page 16)** for the roof holes.

CHIMNEY MODEL*	SQUARE HOLE SIZE OPENING
Secure Temp® S2100+ Nova Temp® HT6000+ Secure Temp GX	15 in (380 mm)
ACBI: Ceiling, Floor and Roof (1" clearance *)	15 in (380 mm)
Wall	17 in (432 mm)
NOTE: See Table 3 for Sloped Roof Framing	
Table 2 - Flat Roof Framing	

* The following exception has been approved for this appliance; The required 2" pipe clearance may be reduced to a 1" clearance at the ceiling, floor and roof penetration points for AC chimney* only. All other locations require 2" clearance.

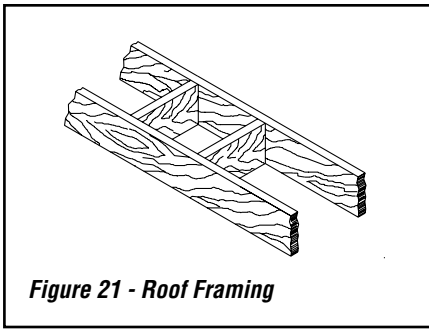

Figure 21 - Roof Framing

2. From below, install a firestop in each ceiling/floor separation through which the chimney will pass. At the attic level, install an attic radiation shield from above (**Figures 22a and 22b**).
3. For Secure Temp® S2100+* / Nova Temp® HT6000+* / Secure Temp GX* chimneys, place the first chimney length on the fireplace. To lock it in place, turn 1/4 of a turn clockwise. With the ACBI chimney*, you must use a starter section before installing the first chimney length (**Figure 23**). Continue installing chimney lengths making sure to lock each length in place.
4. Every time the chimney passes through a ceiling or a wall, install the appropriate firestop. When you reach the desired height, install the roof support. When installing a support, slightly lift the chimney system so the weight will lie on the support, not on the fireplace to reduce expansion noises (Refer to instructions included with the support). For an ACBI chimney* use an universal support AC10SU*.
5. Put the roof flashing in place and seal the joint between the roof and the flashing with roofing pitch (see **Figures 24 and 25**). For sloping roofs, place the flashing under the upper shingles and on top of the lower shingles. Nail the flashing to the roof, using roofing nails.
6. Place the storm collar over the flashing, and tighten it with the bolt supplied. Finally, seal the joint between the storm collar and the chimney, using silicone caulking.
7. Install the chimney cap. Once the chimney cap is in place, the roof flashing can be washed with a solvent or vinegar and then painted with rust-proof paint.

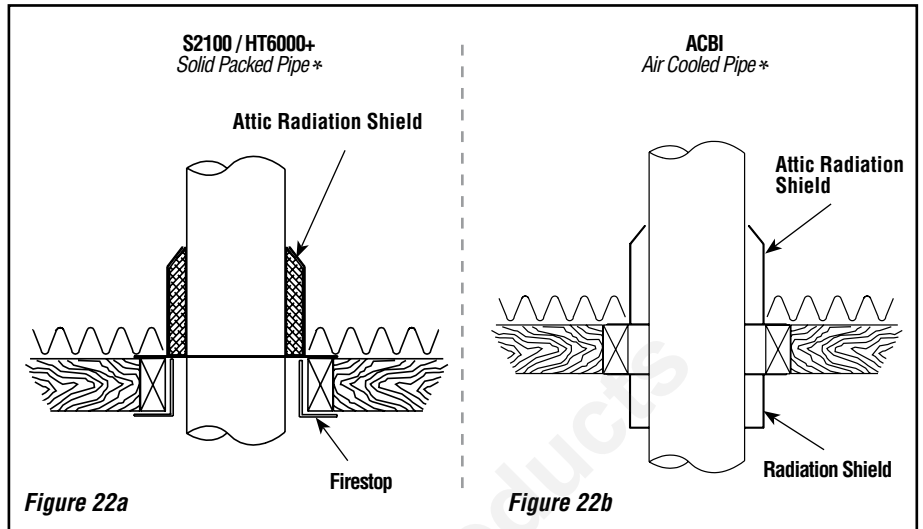

Figure 22a

Figure 22b

CHIMNEY INSTALLATION

MODEL ACBI*

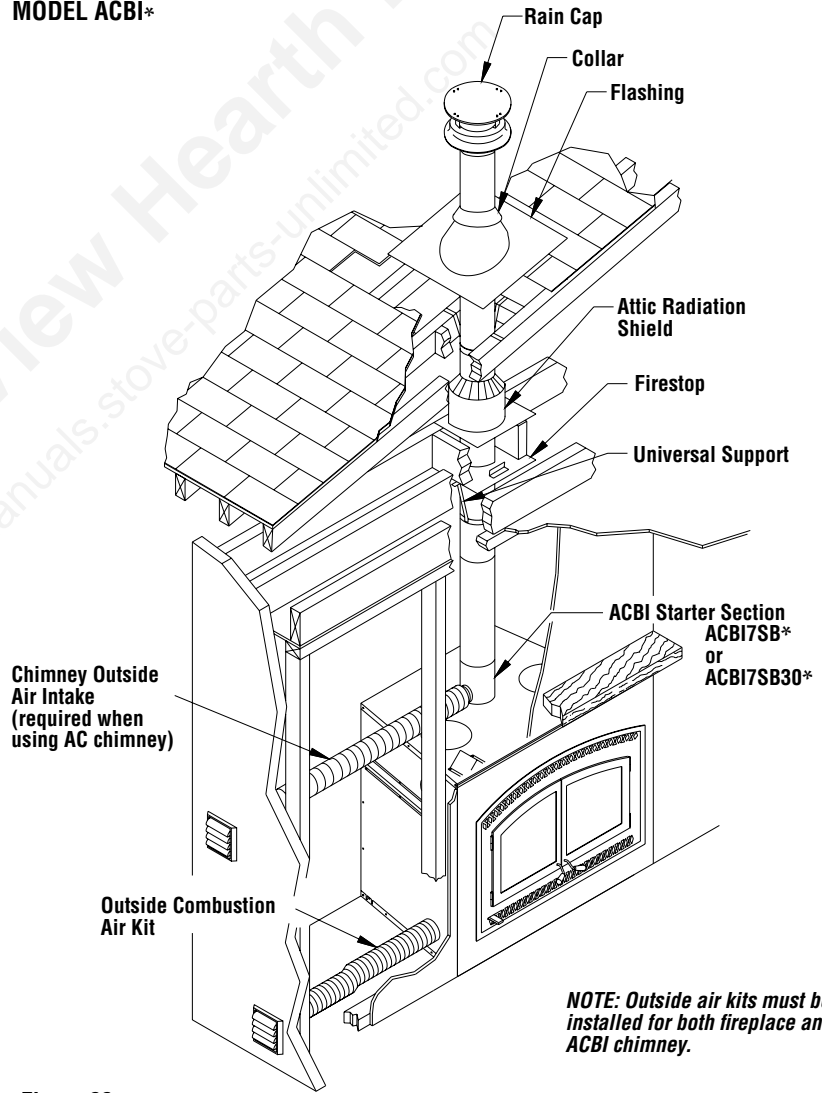
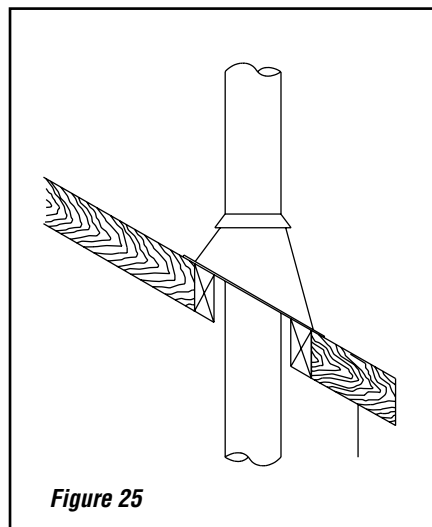
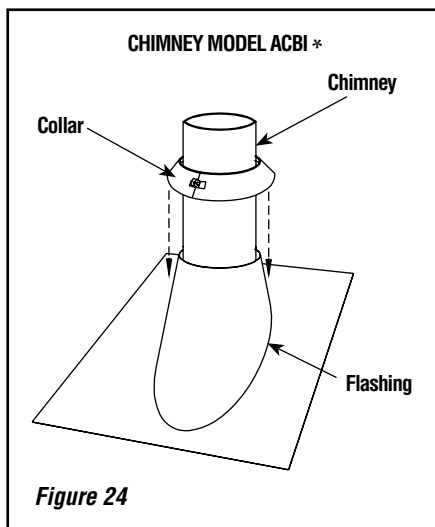

Figure 23



After reaching the location requiring the elbow, proceed as follows:

Secure Temp® S2100+ / Nova Temp® HT6000+ / Secure Temp GX Chimneys *

1. Install the first elbow; turn it in the required direction. Fasten it to the chimney with the three (3) 1/2" (12 mm) metal screws provided with the elbow.
2. Install the necessary chimney lengths to achieve the required offset. Lock the chimney lengths together: it is recommended to use three (3) 1/2" (12 mm) screws. If the offset length is made of two (2) chimney lengths or more, use an offset support halfway up the offset. If penetrating a wall, install a wall radiation shield (see **Figures 27 and 28**).
3. Use another elbow to turn the chimney vertically. Secure the elbow, using three (3) 1/2" (12 mm) screws (provided with the elbow).
4. Use a plumb-bob to line up the center of the hole. Cut a hole for the chimney in the ceiling/floor. Frame this hole as described previously (refer to *Chimney Installation Instructions on Page 14*).
5. From below, install a firestop (See **Figure 22a**).
6. A support (XST+* or XSO+*) must be used on the first 15' section (5 m).
7. Continue with the regular installation.

ACBI Chimney*

1. Install the first elbow. Turn it in the required direction. To lock it in place, turn 1/8 of a turn. Fasten the straps attached to the elbow to the surrounding frame, using nails or drywall screws (**Figure 27**).
2. Install the necessary chimney lengths to achieve the required offset. Lock the chimney lengths together. If penetrating a wall, use a wall radiation shield.
3. Use another elbow to turn the chimney vertically. Lock it to the chimney. Fasten the straps attached to the elbow to the surrounding framing using nails or drywall screws.
4. Use a plumb-bob to line up the center of the hole. Cut a hole for the chimney in the ceiling. Frame this hole as described previously.
5. From below, install a firestop (see **Figure 22b**).
6. Continue with the regular installation.

NOTE: When using ACBI* chimney, an ACBI7SB* (H3258*) starter section must be used before installing an elbow. When an offset is needed immediately off the top of the fireplace, an elbow starter section, ACBI7SB30* (H3259*) is available.

Roof Down Slope Hole Size		
DEGREE OF SLOPE	Secure Temp® S2100+ * Nova Temp® HT6000+ * Secure Temp GX *	ACBI *
Roof Pitch	7"	7"
0 *	15" (380 mm)	15" (380 mm)
2/12	15-3/8" (390 mm)	15-3/8" (390 mm)
4/12	16-1/8" (410 mm)	16-1/8" (410 mm)
6/12	16-7/8" (430 mm)	16-7/8" (430 mm)
8/12	18-1/4" (465 mm)	18-1/4" (465 mm)
10/12	19-5/8" (500 mm)	19-5/8" (500 mm)
12/12	21-3/8" (545 mm)	21-3/8" (545 mm)

* Cross Slope Hole Size
Put the chimney cap into place.
Wash the roof flashing with a solvent or vinegar, then paint it with rust-proof paint.

Table 3

OFFSET CHIMNEY INSTALLATION

After reaching the location requiring the elbow, proceed as follows. The minimum chimney height when using elbows is:

Minimum Chimney Height When Using Elbows	
Fireplace Model	WCT6840WS
Chimney Model*	Secure Temp S-2100+ / Nova Temp HT6000+ / Secure Temp GX / ACBI
Vertical Installation	3.66 m (12')
Two (2) Elbows	4.57 m (15')
Four (4) Elbows	5.18 m (17')

Table 4

NOTES:

- Must return to vertical before penetrating ceiling or floor.
- A maximum of 2 offsets are allowed.

Offset Dimensions

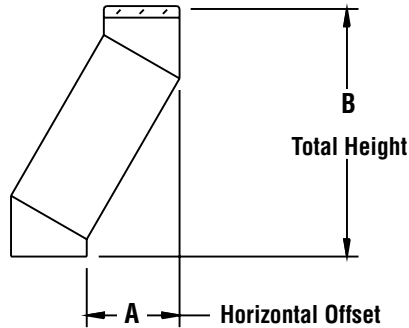

Chimney *	Elbow	Offset & Height	Two Lengths Between Elbows									
			8"	12"	18"	24"	36"	8" & 36"	12" & 36"	18" & 36"	24" & 36"	36" & 36"
GX S2100+ HT6000+ 7"	15°	A	3" (76 mm)	4-1/4" (108 mm)	5-3/4" (146 mm)	7-1/4" (184 mm)	10-1/4" (260 mm)	12-1/4" (311 mm)	13-1/4" (337 mm)	14-3/4" (375 mm)	16-1/4" (413 mm)	19-1/2" (495 mm)
		B	20-3/4" (527 mm)	24-1/4" (616 mm)	29-1/2" (749 mm)	34-3/4" (883 mm)	45" (1143 mm)	51-1/4" (1302 mm)	54-3/4" (1391 mm)	60" (1524 mm)	65-1/4" (1657 mm)	75-1/2" (1918 mm)
	30°	A	7-1/2" (191 mm)	9-1/2" (241 mm)	12-1/2" (318 mm)	15-1/2" (394 mm)	21-1/2" (546 mm)	25" (635 mm)	27" (686 mm)	30" (762 mm)	33" (838 mm)	39" (991 mm)
		B	16-1/2" (419 mm)	20-1/4" (514 mm)	26-1/4" (667 mm)	32" (813 mm)	43-1/2" (1105 mm)	50-1/2" (1283 mm)	54-1/4" (1378 mm)	60" (1524 mm)	65-3/4" (1670 mm)	77-1/2" (1969 mm)
	45° Canada Only	A	10" (254 mm)	12-3/4" (324 mm)	17" (432 mm)	21-1/4" (540 mm)	29-3/4" (755 mm)	34-11/32" (872 mm)	37-5/32" (949 mm)	41-13/32" (1052 mm)	45-21/32" (1160 mm)	54-1/8" (1375 mm)
		B	17-9/16" (446 mm)	20-7/16" (519 mm)	24-5/8" (625 mm)	28-7/8" (733 mm)	37-3/8" (949 mm)	42" (1067 mm)	44-3/4" (1137 mm)	49" (1245 mm)	59-9/32" (1353 mm)	61-3/4" (1568 mm)

Chimney *	Elbow	Offset & Height	One Length Between Elbows					Two Lengths Between Elbows				
			---	12"	18"	36"	48"	---	12" & 48"	18" & 48"	36" & 48"	48" & 48"
ACBI 7"	15°	A	---	5-1/2" (140 mm)	7" (178 mm)	11-1/2" (292 mm)	14-3/4" (375 mm)	---	17-1/2" (445 mm)	19" (483 mm)	23-5/8" (600 mm)	26-3/4" (679 mm)
		B	---	32-1/4" (819 mm)	38" (965 mm)	55-1/2" (1410 mm)	67" (1702 mm)	---	77-1/8" (1959 mm)	82-7/8" (2105 mm)	100-1/4" (2318 mm)	111-1/8" (2823 mm)
	30°	A	---	10-1/2" (267 mm)	13-1/2" (343 mm)	22-1/2" (543 mm)	28-1/2" (724 mm)	---	33-3/4" (857 mm)	36-3/4" (933 mm)	45-3/4" (1162 mm)	51-3/4" (1314 mm)
		B	---	30-1/8" (765 mm)	35-3/8" (899 mm)	51" (1295 mm)	61-3/8" (1559 mm)	---	70-1/2" (1791 mm)	75-5/8" (1921 mm)	91-1/4" (2318 mm)	101-5/8" (2581 mm)

NOTE: With the ACBI chimney[®], a starting length of 6" high must be used on top of the fireplace before installing an elbow.

Figure 26

OFFSET CHIMNEY INSTALLATION *

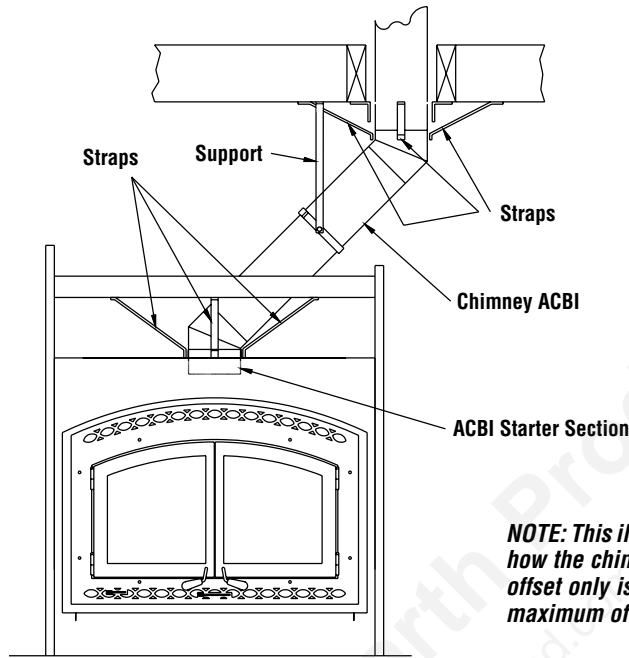

NOTE: This illustration is not to scale. It represents how the chimney must be supported. A 30 degree offset only is allowed in the USA and a 45 degree maximum offset is allowed in Canada.

Figure 27

OFFSET CHIMNEY INSTALLATION WITH WALL PENETRATION *

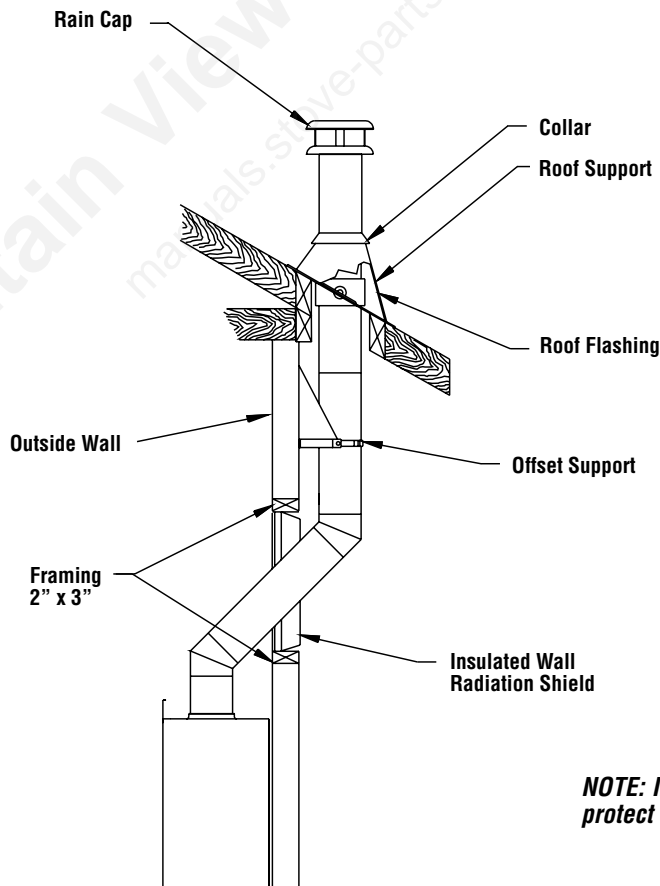

NOTE: In cold areas it is recommended to protect the chimney in a insulated chase.

Figure 28

ANGLED WALL RADIATION SHIELD * (XRSMI30 and AC10RSMI30)

When traversing a combustible wall with the chimney at a 30° or 45° angle, an angled firestop or wall radiation shield must be installed. Only one is required.

NOTE: 45° angle for Canada only (XRSMI45 *).

In cold climate locations (climates where temperatures will fall below 32° F / 0° C), we recommend that you use the insulated wall radiation shield since it will maintain the home's thermal barrier.

XRSMI30 and AC10RSMI30 (XRSMI45 - Canada Only)		
Chimney Model (7" dia).*	Angle	Hole Size
Secure Temp® S2100+ Nova Temp® HT6000+ Secure Temp GX (US only)	30°	15" x 38-1/4" (380 mm x 972 mm)
Secure Temp S2100+ Nova Temp HT6000+	45° Canada only	15" x 25-7/8" (380 mm x 657 mm)
ACBI	30°	17 x 42-1/2" (432 mm x 1080 mm)

Table 5

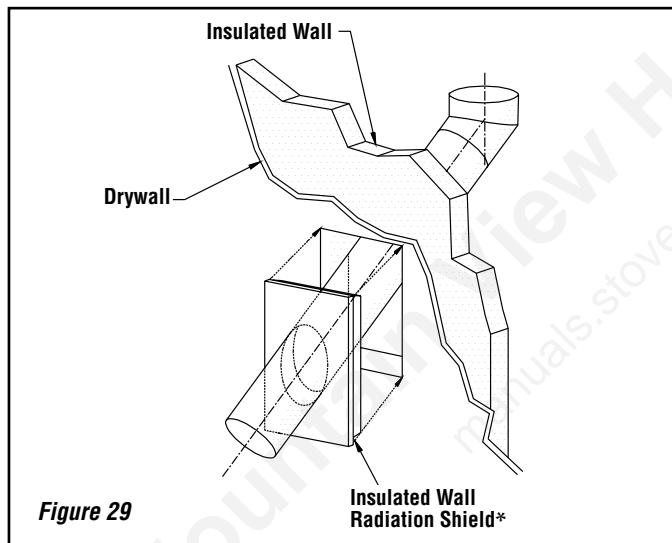

Figure 29

CHIMNEY SUPPORT INSTALLATION

Universal Roof Support

When installing a support, slightly lift the chimney system so the weight will lie on the support, not on the fireplace to reduce expansion noises. This support has three possible uses:

1. For Secure Temp® S2100** / Nova Temp® HT6000** / Secure Temp GX*, it must be used on a roof to support the chimney.
2. It may be used on a floor, ceiling or roof above an offset to support the chimney above the offset.
3. It may be used on a floor, ceiling or roof as a supplementary support when the chimney height exceeds 15 feet (4.6 m).

Table 6 gives maximum height of supported chimney.

NOTE: For the ACBI chimney*, a support section (ACBI7SL*) must be used every 30 feet (9m) or an universal support every 20 feet (6m) instead of the universal roof support (ST*).

For roof support installation, refer to the instructions provided with the support.

UNIVERSAL OFFSET SUPPORT

This support is used to support the chimney above an offset. When the chimney offset is used to traverse a wall this support may be used on the wall to support the chimney. The maximum heights are given in **Table 6**. For offset support installation, refer to the instructions provided with the support.

CHIMNEY*	MAXIMUM HEIGHT OF SUPPORTED CHIMNEY	
	Offset Support	Roof Support
Secure Temp S2100+ Nova Temp HT6000+ Secure Temp GX	16 feet (5.49 m).	18 feet (6.1 m).
ACBI	40 feet (12.19 m).	50 feet (15.20 m).

Table 6

CHIMNEY CHASE AND MULTIPLE TERMINATIONS

For the purpose of this manual, a chimney chase is considered a part of the chimney system rather than part of a building. The termination must be placed a minimum of 18" (460 mm) above the chase.

For installations where more than one chimney is located in the same chase or within the same area, we suggest that their terminations be separated by at least 16" (410 mm) horizontally, and 18" (460 mm) vertically. This separation is to prevent smoke migrating from one chimney to another (see **Figure 30**).

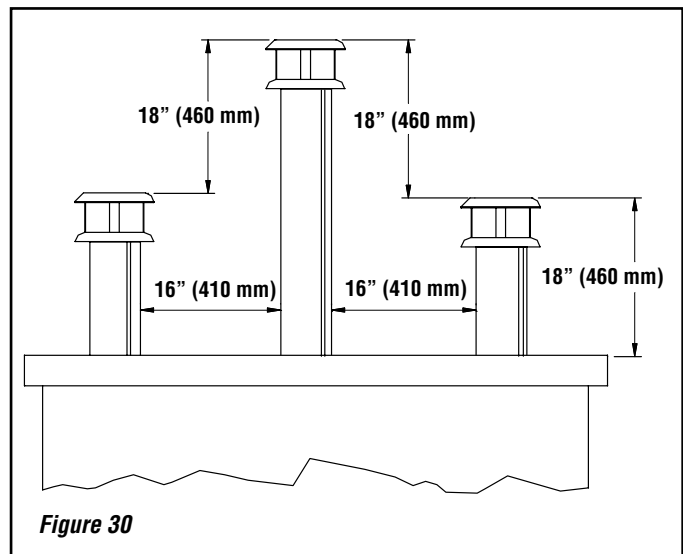

Figure 30

INSTALLATION INSTRUCTIONS FOR MASONRY APPLICATION

WARNING: Before starting the installation, the masonry chimney must be inspected by a qualified chimney sweep.

The following requirements must be respected:

1. The chimney must be absolutely clear of any soot residue or creosote. Check for cracks, loose or missing bricks that could inhibit correct installation of the liner.
2. The clearance to combustibles must be a minimum of 1" between the outside of the masonry and any wood framing or loose insulation.
3. The chimney must be built in accordance with the current building code.
4. No other appliance can be connected to the same chimney.
5. The clearances to combustibles for the BISTMA30* connectors are 2" on the side and bottom and 16" at the top.
6. The connector parts are not necessary if the connection between the insulated length and the stainless steel liner is done within the masonry chimney.

Installation:

The chimney must be relined with a stainless steel liner model Tubinox™* or Projet® SS* of the same diameter as the outlet of the fireplace.

For connection at 30° angle, a special connector (BISTMA30*) must be used to connect the liner to the insulated chimney.

*** IMPORTANT NOTE - The use of a 45° connector (BISTMA*) is approved for use in Canada ONLY. Installations in the USA must use the 30° connector (BISTMA30*).**

Follow these steps:

- 1- Position the fireplace in its location. Temporarily install the S2100+ elbow* on the top of the fireplace and, using a level, mark with an oval the location where the flue liner will enter the masonry chimney.
- 2- In the middle of the oval, drill a hole in the masonry chimney at 30°.
- 3- Increase the size of the hole until a 30° Tubinox* liner elbow can be easily slipped through.
- 4- Slide the liner down from the top of the masonry chimney until you reach the hole level.
- 5- Slip through the hole a 30° liner elbow and connect it to the liner.
- 6- Add a small liner section to the liner elbow which will allow the liner to extend at least 12" (measured at the top of the liner) from the masonry chimney.
- 7- Seal the opening around the liner with high temperature refractory cement.
- 8- The next steps must be done in the following order:

See typical installation illustrated below.

- A. Select the S2100+ length* that will fit between the elbow and the liner so that it will slide at least 2" over the liner section (You may need to cut the liner for a better fit).
- B. Take that section and the BISTMA30* cover and slide it over the liner. Make sure you have enough opening to be able to install the S2100+ elbow* without difficulty.
- C. Install the 30° elbow on the fireplace.
- D. Slide the length section back down on the elbow and twist lock the two together.
- E. Pull the cover down over the length and install the insulation pad over the liner; be careful to cover the liner completely.
- F. Slide back the cover over the insulation and fix it in place using the 3 metal screws supplied.

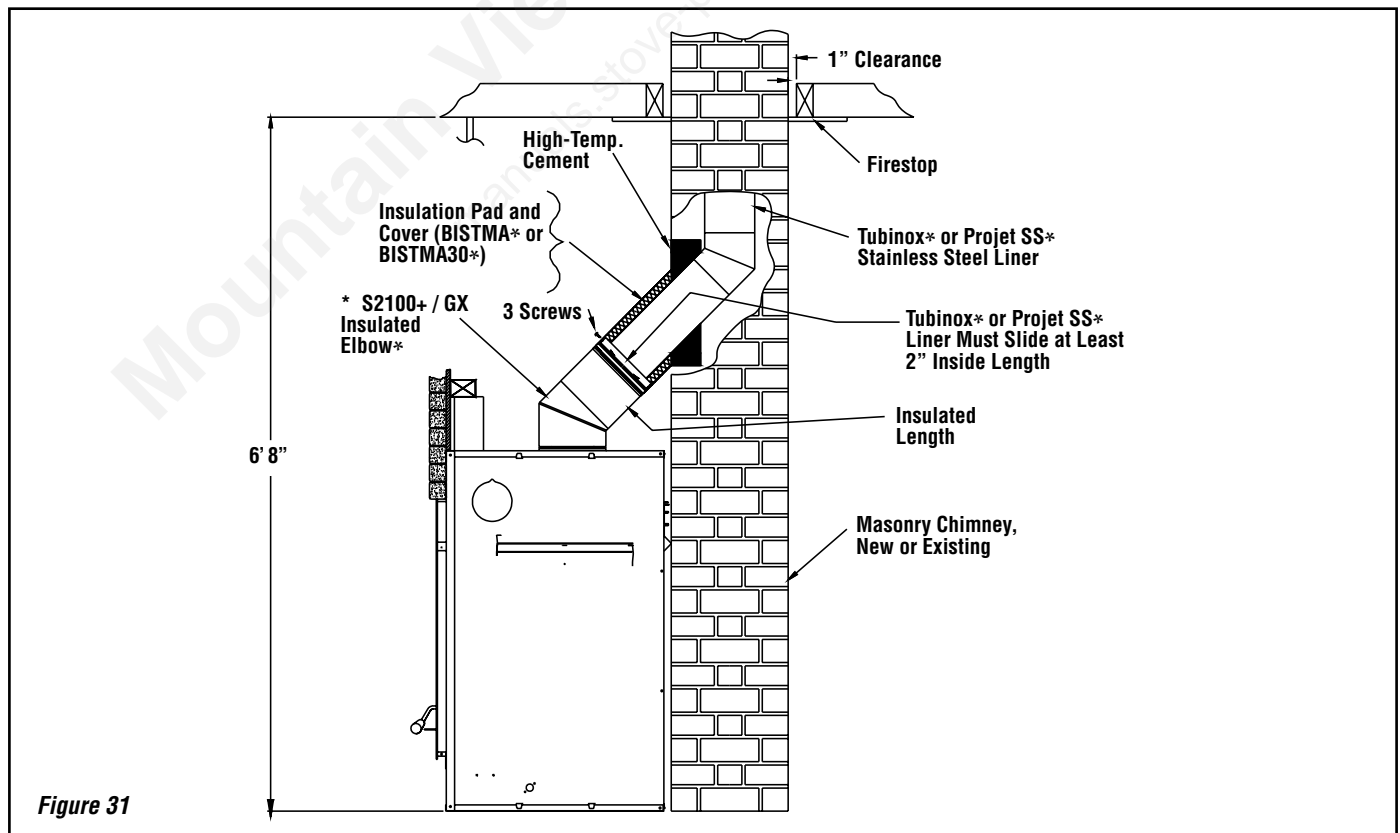

Figure 31

OPTIONAL INSTALLATION ACCESSORIES

Installation Accessories	
Description	Cat./Part No.
Facades (Required - Order Separately)	
WCT6840WS Facade Black, BTFBK	BTFBK
WCT6840WS Facade Hammered Steel, BTFMC	BTFMC
Doors - (Required - Order Separately)	
WCT6840WS Doors Black, BTCBK	F1852
WCT6840WS Doors Hammered Steel, BTCMC	F1853
Outside Air Kit (included with fireplace)	
Outside Air Coupler To Connect Outside Air (UZI) To Fireplace, UZIAD	UZIAD
Outside Air Ducting - includes 4" insulated flex x 10' long, UZI	UZI
Gravity Kit	
Gravity kit: Complete double duct system includes: 2 elbows 90°, 2 telescopic lengths, 2 grill supports and 2 black grills, 2 fireplace adaptors. , 7B30ZK-1	H8947
Gravity Kit Accessories	
Elbow 90°, 8" dia., 7B26ZE90	H8948
Elbow 45°, 8" dia., 7B26ZE45	H8949
Telescopic length, 8" dia. (15" to 26"), 7B26ZLA	H8950
Adjustable length 8" dia (2" - 5"), 7B26ZL2A	H8951
Length two (2) feet, 8KL2	H8954
Length one (1) feet, 8KL1	H8953
Wall radiation shield, 8" I.D., 7B26ZR	H8952

Fireplace Kits	
Description	Cat./Part No.
Rigid firescreen, BTZN	BTZN
Central Forced Air Kit Accessories ❶	
Central Forced Air Kit, Central forced air kit including: blower (BISZY), flex adaptor (BISAF), 2 clamps, variable speed control (VRUW), thermo-disk (VTU), fan to flexible pipe adapter (BISAVF), back draft damper (BISBD), aluminium tape, BISFWK-1	BISFWK-1
Flexible pipe 5" I.D. x 15 ft. Long, 5FLEX15	5FLEX15
Flexible pipe 5" I.D. x 30 ft. Long, 5FLEX25	5FLEX25
Heating and cooling thermostat, 24V, HCTW	HCTW

❶ **Not tested under EPA certification. If installed, this appliance no longer qualifies for EPA certification.**

REPLACEMENT PARTS LIST

WCT6840WS - Replacement Parts	
Description	Cat./Part No.
Fireplace Blower	PR-UZY7
Blower Motor Speed Control	VRUW
Snap Disc, Blower	VTU
Baffle refractory (2 pieces) (top of firebox)	PR-IS02205
Top Hearth Insulation	PR-IS02521
Front Refractory Bricks	PR-SR2421
Back Refractory Brick	PR-SR2415
Right Side Refractory Bricks - Back	PR-SR2417
Right Side Refractory Bricks - Front	PR-SR2419
Left Side Refractory Bricks - Back	PR-SR2416
Left Side Refractory Bricks - Front	PR-SR2418
Bottom Refractory Brick	PR-SR2422
Wooden Door Handle	PR-SR1787
Door Latch (top and bottom)	PR-SR2543
Hinge Assembly, Fireplace and Door	PR-SR1800T
Decorative Screw Caps, Black (2)	PR-SACMEFBK
Decorative Screw Caps, Brushed Nickel (2)	PR-SACMEFBN
Timer	PR-SR2425
Ceramic Glass Left	PR-SR2356G
Ceramic Glass Right	PR-SR2356D
Secondary Air Tube (4)	PR-SR2379
Log Retainers (2)	PR-B2CH
Around the Glass Gasket (61-3/4")	PR-SR1685C
On the Door Frame Gasket (48-3/8")	PR-SR1823I
Between the Doors Gasket (17-5/8")	PR-SR1823J
Door Radiation Shield Kit	PR-SR2401KIT
Touch-up Paint, Aerosol, Black Metallic	H8159
Touch-up Paint, Charcoal (for hammered steel facade)	PR-P6201
Outside Air Coupler For AC Chimney 4" ID, UACZI	H3274
Outside Air Coupler To Connect Outside Air (UZI) To Fireplace, UZIAD	UZIAD
Blower 250 CFM for central forced air kit, BISZY	BISZY
Blower variable speed control with decorative wall plate for (BISZY), VRUW	VRUW
Thermo-disk, on/off blower control (for BISZY), VTU	VTU
Blower to flexible pipe adaptor, BISAVF	BISAVF
Backdraft damper, BISBD	BISBD
Fireplace to Flex adaptor and 2 clamps, BISAF	BISAF

Contact an IHP dealer to obtain any of these parts. Never use substitute materials not approved by IHP. Use of non-approved parts can result in poor performance and safety hazards.

SPECIFICATIONS

Cat. No.	Model
F1791	WCT6840WS

Product Reference Information	
Weight	450 lbs
Height	49-3/8"
Width	46-1/4"
Depth	27"
Firebox W x H x D measured in front	31" x 14-1/2" x 14"
Chimney weight - Secure Temp® GX (7" dia)	9.5 lb per linear foot
Chimney weight - ACBI	3.75 lb per linear foot

CLEARANCE TO COMBUSTIBLES

The following clearances meet the minimum requirements for a safe installation:

Side wall (fireplace front): 24" (457 mm) measured from the fireplace side.

Ceiling: 6' 8" (2,032 mm) measured from the base of the fireplace

Fireplace enclosure:

Bottom: 0"

Side: 0" to spacer

Back: 0" to spacer

Top: Do not fill the space above the fireplace with any material (Except the wood framing. See **Figure 10**)

Chimney: 2" (50 mm), except for through ceiling application, ACBI chimney, 1" (25 mm) clearance.

Mantel: 56" (1422 mm) measured from the base of the fireplace.

SECURITY CHIMNEYS™ - PARTS AND COMPONENTS LISTS

The components listed below must be ordered from Security Chimneys International™. Contact your Security Chimneys Distributor or Dealer for ordering information.

Security Chimneys International Limited 450-973-9999
 2125 Monterey, Laval, Quebec 1-800-361-4909 (USA)
 Canada, H7L 3T6 1-800-667-3387 (Canada)
 www.securitychimneys.com

Secure Temp® GX - 2" Insulated Galvanized Chimney System (Recommended Insulated System) <i>Galvanized (7" ID and 11" OD) U.S.A. ONLY</i>	
Description	Cat./Part No.
Lengths and Misc. Chimney Components	
Length 8", 7GXL8	7GXL8
Length 12", 7GXL12	7GXL12
Length 18", 7GXL18	7GXL18
Length 24", 7GXL24	7GXL24
Length 24" (stainless steel exterior flue), 7XL24	7XL24
Length 36", 7GXL36	7GXL36
Length 36" (stainless steel exterior flue), 7XL36	7XL36
Length 48", 7GXL48	7GXL48
Length 48" (stainless steel exterior flue), 7XL48	7XL48
15° Elbow, 7GXE15	7GXE15
30° Elbow, 7GXE30	7GXE30
Rain Termination Cap, 7CC (stainless steel)	7CC
Wall Band, XBM	XBM
Supports	
Offset Support, XSO	XSO
Roof / Floor support, XST	XST
Roof Brace, XBS2	XBS2
Roof Flashings	
Roof Flashing, Flat (includes spacer and collar), 7XF	7XF
Roof Flashing, Adjustable (5° to 30°) (includes spacer and collar), 7XFA	7XFA
Roof Flashing, Adjustable (30° to 45°) (includes spacer and collar), 7XFB	7XFB
Storm Collar (spacer included), 7XFC	7XFC
Firestops and Braces	
Firestop, 7XBF	7XBF
Radiation shield, 7XRS	7XRS
Insulated attic radiation shield, 7XRSA	7XRSA2
30° Insulated wall radiation shield, 7XRSMI30	7XRSMI30
Wall Band, XBM	XBM

Fireplace Model WCT6840WS - Approved Venting Components manufactured by Security Chimneys International™ only.

- **7" diameter chimney** - ACBI (air cooled), Secure Temp® GX (U.S. only) and Secure Temp S-2100+ (or Nova Temp® HT6000+).
- **7" diameter chimney for relining masonry chimneys** - Tubinox™ chimney (or Projet® SS), 7" diameter with adaptor for installation in a masonry chimney.

NOTES:

- ① *Nova Temp HT6000+ is equivalent to S-2100+*
- ② *Chimney Adaptor (S-2100+ / HT6000+) for CANADA ONLY - If you want to install a S-2100+ / HT6000+ chimney, an adaptor is available (7UCA).*
- ③ *ACBI Chimney is NOT recommended at elevations above 4,000 feet or in cold climates (climates where temperatures will fall below 32° F / 0° C). When using ACBI chimney, an ACBI7SB starter section must be used before installing an elbow. When an offset is needed immediately off the top of the fireplace, an elbow starter section (ACBI7SB30) is available.*

SECURITY CHIMNEYS™ - PARTS AND COMPONENTS LISTS

The components listed below must be ordered from Security Chimneys International™. Contact your Security Chimneys Distributor or Dealer for ordering information.

Security Chimneys International Limited 450-973-9999
 2125 Monterey, Laval, Quebec 1-800-361-4909 (USA)
 Canada, H7L 3T6 1-800-667-3387 (Canada)
 www.securitychimneys.com

ACBI Chimney* (7" I.D., 13" O.D. AC - Air Cooled)	
<i>* AC Chimney is NOT recommended at elevations above 4,000 feet or in cold climates (climates where temperatures will fall below 32° F / 0° C).</i>	
Description	Cat./Part No.
One of the following adaptors is required if installing an AC chimney system	
Starter Section w/ air intake, 7" Dia., ACBI7SB	H3258
Offset Starter Section 30°, 7" Dia., ACBI7SB30	H3259
The following outside air kit is required if installing an AC chimney system	
Outside Air Kit (Chimney) (4" ID Flex X 10' Long, Insulation, Outside Register And Coupling), ACZI	H1967
Lengths and Misc. Chimney Components	
12" Length, 7" Dia., ACBI7L12	H3252
18" Length, 7" Dia., ACBI7L18	H3253
36" Length, 7" Dia., ACBI7L36	H3254
48" Length, 7" Dia., ACBI7L48	H3255
15° Elbow, 7" Dia., ACBI7E15	H3256
30° Elbow, 7" Dia., ACBI7E30	H3257
Rain Termination Cap (regular), 7" Dia., ACBI7CPR	H3260
Spark Arrester Screen (universal spark arrester band), PE	PE
Wall Band, XBM	XBM
Supports	
Support section (10" long), ACBI7SL	H3263
Universal support, AC10SU	H3265
Roof Flashings	
Flat roof flashing (includes spacer and collar), ACBI7FR	H3275
Roof Flashing, Adjustable, 5° - 30° (includes spacer and collar), ACBI7FAR	H3276
Roof Flashing, Adjustable, 30° - 45° (includes spacer and collar), ACBI7FBR	H3277
Misc.	
Firestop, ACBI7BF	H3268
Radiation Shield, ACBI7RS	H3269
Attic Radiation Shield, ACBI7RSA	H3270
Telescopic Attic Radiation Shield, ACBI7RST	H3271
Insulated Wall Radiation Shield 30°, AC10RSMI30	H3272
Storm Collar, AC10FC	H3278

Tubinox™ LL Chimney Lining System Rigid Stainless Steel Liner For Relining A Masonry Chimney, 7" Diameter <i>Listed to ULC-S635M, UL-1777 and ULC-S640M at 2100° F</i>	
Description	Cat./Part No.
6" Length, 7" Dia., 7LL6	7LL6
12" Length, 7" Dia., 7LL12	7LL12
24" Length, 7" Dia., 7LL24	7LL24
36" Length, 7" Dia., 7LL36	7LL36
48" Length, 7" Dia., 7LL48	7LL48
Adjustable Length (7" to 11"), 7" Dia., 7L7A	7L7A
Split Base Tee, 7" Dia., 7LT	7LT
Tee Cap, 7" Dia., 7TCS	7TCS
Twist Lock Tee Cap, 7" Dia., 7LTC	7LTC
Elbow 30°, 7" Dia., 7LE30	7LE30
Elbow 45°, 7" Dia., 7LE45	7LE45
Elbow 90°, 7" Dia., 7LE90	7LE90
Rain Termination Cap (regular), 7" Dia., 7LCS	7LCS
Rain Termination Cap (deluxe), 7" Dia., 7LCC	7LCC
Supports	
Top Support, Part# 7LST	7LST
Support Assembly, 7LSA	7LSA
Interior Support, Part# 7LSB	7LSB
Adaptor Flexible Pipe (male), 7LAAM	7LAAM
Adaptor Flexible Pipe (female), 7LAAF	7LAAF
Stainless Steel Flex - five (5) feet Long, 7LLFLEX	7LLFLEX
Adj. Insulated Wall Radiation Shield 6" to 12", 7LRSMI	7LRSMI
Adaptors to Masonry Chimney	
Masonry Chimney Adaptor, 45°, BISUMA (for use with Tubinox liner) CANADA ONLY	BISUMA
Masonry Chimney Adaptor, 30°, BISTMA30 (for use with Tubinox liner)	BISTMA30

Gravity Kit Accessories	
Elbow 90°, 8" dia., 7B26ZE90	7B26ZE90
Elbow 45°, 8" dia., 7B26ZE45	7B26ZE45
Telescopic length, 8" dia. (15" to 26"), 7B26ZE45	7B26ZE45
Adjustable length 8" dia (2" - 5"), 7B26ZE45	7B26ZE45
Wall radiation shield, 8" I.D., 7B26ZR	7B26ZR
Black grill with support, 7B30ZO	7B30ZO
Brass grill (for 7B30ZK), 7B30ZGB	7B30ZGB
Length one (1) feet, 8KL1	8KL1
Length two (2) feet, 8KL2	8KL2
Length three (3) feet, 8KL3	8KL3
Length four (4) feet, 8KL4	8KL4
Length five (5) feet, 8KL5	8KL5

Innovative Hearth Products Superior™ Brand Wood-Burning Fireplace 20 Year Limited Warranty

THE WARRANTY

Innovative Hearth Products ("IHP") 20 Year Limited Warranty warrants your Superior™ Brand wood burning fireplace ("Product") to be free from defects in materials and workmanship at the time of manufacture. The Product body, firebox and ceramic glass carry the 20 Year Limited Warranty. Ceramic glass carries the 20 Year Limited Warranty against thermal breakage only. After installation, if covered components manufactured by IHP are found to be defective in materials or workmanship during the 20 Year Limited Warranty period and while the Product remains at the site of the original installation, IHP will, at its option, repair or replace the covered components. If repair or replacement is not commercially practical, IHP will, at its option, refund the purchase price or wholesale price of the IHP product, whichever is applicable. IHP will also pay IHP prevailing labor rates, as determined in its sole discretion, incurred in repairing or replacing such components for up to five years. THERE ARE EXCLUSIONS AND LIMITATIONS to this 20 Year Limited Warranty as described herein.

COVERAGE COMMENCEMENT DATE

Warranty coverage begins on the date of installation. In the case of new home construction, warranty coverage begins on the date of first occupancy of the dwelling or six months after the sale of the Product by an independent IHP dealer/distributor, whichever occurs earlier. The warranty shall commence no later than 24 months following the date of product shipment from IHP, regardless of the installation or occupancy date.

EXCLUSIONS AND LIMITATIONS

This 20 Year Limited Warranty applies only if the Product is installed in the United States or Canada and only if operated and maintained in accordance with the printed instructions accompanying the Product and in compliance with all applicable installation and building codes and good trade practices.

This warranty is non-transferable and extends to the original owner only. The Product must be purchased through a listed supplier of IHP and proof of purchase must be provided. The Product body and firebox carry the 20 Year Limited Warranty from the date of installation. Vent components, trim components, paint and applied stains are excluded from this 20 Year Limited Warranty. The following do not carry a 20 Year Limited Warranty but are warranted as follows:

Air tubes, baffles and brick retainers – Repair or replacement for one year from the date of installation

Cast iron parts – Replacement for one year from date of installation

Catalyst – Carries a separate warranty. Refer to the warranty certificate provided for that part

Electrical components – Repair or replacement for one year from the date of installation

Fireplace screens, refractory and side shields (metal or refractory) – Repair or replacement for two years from date of installation. Excludes hairline cracks.

Fuel grates – These parts are considered consumable accessories and therefore are not warranted, with the exception of defects in material or workmanship which are covered for 90 days from the date of installation

Gaskets – Replacement for one year from date of installation

Gold & nickel plating – Replacement for two years from date of installation. Excludes tarnishing

Optional glass doors – Repair or replacement for 90 days from the date of installation

Refractory & screens – Replacement for two years from date of installation. Excludes hairline cracks

Removable air tubes – Repair or replacement for seven years from date of installation. IHP prevailing labor rates for years one through five.

Labor coverage – Prevailing IHP labor rates apply for the warranty period of the component.

Parts not otherwise listed carry a 90 day warranty from the date of installation.

Whenever practicable, IHP will provide replacement parts, if available, for a period of 10 years from the last date of manufacture of the Product.

IHP will not be responsible for: (a) damages caused by normal wear and tear, accident, riot, fire, flood or acts of God; (b) damages caused by abuse, negligence, misuse, or unauthorized alteration or repair of the Product affecting its stability or performance. (The Product must be subject to normal use with approved fuels listed in the Operation Manual provided with the product. This includes burning such fireplace fuels as wood and natural or propane gas. Fuel products with abnormal burning characteristics, including but not limited to fuel such as driftwood, coal or plywood and wood products using a binder may burn at excessive temperatures and may cause damage to the Product or may cause it to function improperly.); (c) damages caused by failing to provide proper maintenance and service in accordance with the instructions provided with the Product; (d) damages, repairs or inefficiency resulting from faulty installation or application of the Product.

Coverage of this 20 Year Limited Warranty is conditional upon use of an adequate fuel grate on factory-built fireplaces only, when applicable.

IHP is not responsible for inadequate fireplace system draft caused by air conditioning and heating systems, mechanical ventilation systems, or general construction conditions which may generate negative air pressure in the room in which the appliance is installed. Additionally IHP assumes no responsibility for smoking conditions caused by inadequate chimney height, adjoining trees or buildings, adverse wind conditions or unusual environmental factors and conditions. Certain IHP Products are listed for use with Security Chimneys International, Ltd. or IHP chimney systems only. Use of chimney components other than that specified in the Product manual will void the Product warranty.

This 20 Year Limited Warranty covers only parts and labor as provided herein. In no case shall IHP be responsible for materials, components or construction which are not manufactured or supplied by IHP or for the labor necessary to install, repair or remove such materials, components or construction. Additional utility bills incurred due to any malfunction or defect in equipment are not covered by this 20 Year Limited Warranty. All replacement or repair components will be shipped F.O.B. from the nearest stocking IHP factory.

LIMITATION ON LIABILITY

It is expressly agreed and understood that IHP's sole obligation and the purchaser's exclusive remedy under this warranty, under any other warranty, expressed or implied, or in contract, tort or otherwise, shall be limited to replacement, repair, or refund, as specified herein.

In no event shall IHP be liable for any incidental or consequential damages caused by defects in the Product, whether such damage occurs or is discovered before or after replacement or repair, and whether such damage is caused by IHP's negligence. IHP has not made and does not make any representation or warranty of fitness for a particular use or purpose, and there is no implied condition of fitness for a particular use or purpose.

IHP makes no expressed warranties except as stated in this 20 Year Limited Warranty. The duration of any implied warranty is limited to the duration of this expressed warranty.

No one is authorized to change this 20 Year Limited Warranty or to create for IHP any other obligation or liability in connection with the Product. Some states and provinces do not allow the exclusion or limitation of incidental or consequential damages, so the above limitations or exclusions may not apply to you. The provisions of this 20 Year Limited Warranty are in addition to and not a modification of or subtraction from any statutory warranties and other rights and remedies provided by law.

INVESTIGATION OF CLAIMS AGAINST WARRANTY

IHP reserves the right to investigate any and all claims against this 20 Year Limited Warranty and to decide, in its sole discretion, upon the method of settlement.

To receive the benefits and advantages described in this 20 Year Limited Warranty, the appliance must be installed and repaired by a licensed contractor approved by IHP.

Contact IHP at the address provided herein to obtain a listing of approved dealers/distributors. **IHP shall in no event be responsible for any warranty work done by a contractor that is not approved without first obtaining IHP's prior written consent.**

HOW TO REGISTER A CLAIM AGAINST WARRANTY

In order for any claim under this warranty to be valid, you must contact the IHP dealer/distributor from which you purchased the product. If you cannot locate the dealer/distributor, then you must notify IHP in writing. IHP must be notified of the claimed defect in writing within 90 days of the date of failure. Notices should be directed to the IHP Warranty Department at 1508 Elm Hill Pike, Suite 108; Nashville, TN 37210 or visit our website at WWW.SUPERIORFIREPLACES.US.COM.

WARRANTY

Your fireplace is covered by a limited warranty. Please read the warranty to be familiar with its coverage.

Retain this manual. File it with your other documents for future reference.

PRODUCT REFERENCE INFORMATION

We recommend that you record the following important information about your fireplace. Please contact your IHP dealer for any questions or concerns.

REPLACEMENT PARTS

See **Page 22** for a complete replacement parts list. Use only parts supplied from the manufacturer.

Normally, all parts should be ordered through your IHP distributor or dealer. Parts will be shipped at prevailing prices at time of order.

When ordering repair parts, always give the following information:

1. The model number of the appliance.
2. The serial number of the appliance.
3. The part number.
4. The description of the part.
5. The quantity required.
6. The installation date of the appliance.

If you encounter any problems or have any questions concerning the installation or application of this system, please contact your dealer.

IHP

1508 Elm Hill Pike, Suite 108

Nashville, TN 37210

Visit us at www.SuperiorFireplaces.us.com

Model Number	_____
Serial Number	_____
Date Installed	_____
Dealer's Name	_____
Dealer's Phone Number	_____



We recommend that our woodburning hearth products be installed and serviced by professionals who are certified in the U.S. by the National Fireplace Institute® (NFI) as NFI Woodburning Specialists or who are certified in Canada by Wood Energy Technical Training (WETT).



IHP reserves the right to make changes at any time, without notice, in design, materials, specifications, and prices, and also to discontinue colors, styles, and products. Consult your local distributor for fireplace code information.

