

Put LOPI Logo Here

OWNER'S MANUAL

PREPARATION, INSTALLATION, OPERATION AND MAINTENANCE
KEEP THIS MANUAL

September, 1992

- **Masonry
Fireplace
Insert**

Flush Bay 96

(E.P.A. Phase II Approved)

Tested to U.L. 127, U.L. 1482, U.L. 907 Standards by:
Warnock Hersey Professional Services, LTD

Manufactured by:

INTRODUCTION

We welcome you as a new owner of a wood heating appliance. In purchasing a Lopi Flush Bay 96 you have joined the growing ranks of concerned individuals whose selection of an energy system reflects both a concern for the environment and aesthetics. The Lopi Flush Bay 96 is one of the finest home heaters the world over. This manual will illustrate and detail the variety of uses and applications for your heating appliance. Please familiarize yourself with the Owner's Manual before installing your appliance and save the manual for future reference. This manual covers in detail the necessary steps required in assembling and installing your appliance to meet all safety codes. Included are helpful hints and suggestions which will make the installation and operation of your new appliance an easier and more enjoyable experience. We offer our continual support and guidance to help you achieve the maximum benefit and enjoyment from your appliance.

Many years of warmth,

President

Plant Manager

Technical Director

Dir. of Engineering

Production Manager

Controller

Foreman

Customer Service Mgr.

Q.C. Manager

Shipping Manager

Sales Manager

Sales Manager

Sales

IMPORTANT INFORMATION

Record Important Product Data Here

No other Lopi Flush Bay 96 appliance has the same serial number as yours. You will find the serial number on the backside of the appliance.

This serial number will be needed in case you require service of any type.

Model: _____

Serial Number: _____

Purchase Date: _____

Purchased From: _____

Mail your Warranty Card Today, and Save Your Bill of Sale.

To receive full warranty coverage, you will need to show evidence of the date you purchased your appliance. Do not mail your Bill of Sale to us.

We suggest that you attach your Bill of Sale to this page so that you will have all the information you need in one place should the need for service or information occur.

SAFETY PRECAUTIONS

- VIEWING DOOR MUST BE CLOSED AND LATCHED DURING OPERATION.
- THE APPLIANCE IS DESIGNED AND APPROVED FOR BURNING OF WOOD ONLY. THE BURNING OF ANY TYPE FUEL OTHER THAN WOOD WILL VOID ALL WARRANTIES AND SAFETY LISTING OF THE APPLIANCE. DO NOT ATTEMPT TO BURN ANY OTHER FUEL THAN SPECIFIED IN THIS MANUAL.
- THIS APPLIANCE MUST BE PROPERLY INSTALLED IN ORDER TO PREVENT THE POSSIBILITY OF A HOUSE FIRE. FOR YOUR SAFETY THE INSTALLATION INSTRUCTIONS MUST BE STRICTLY ADHERED TO. DO NOT USE MAKESHIFT METHODS OR COMPROMISE IN INSTALLATION.
- THE FLUE SYSTEM SHOULD BE CHECKED TWICE A YEAR MINIMUM FOR ANY BUILD-UP OF SOOT OR CREOSOTE.
- CONTACT YOUR LOCAL BUILDING OFFICIALS TO OBTAIN A PERMIT AND INFORMATION ON ANY INSTALLATION RESTRICTIONS OR INSPECTION REQUIREMENTS IN YOUR AREA. ALSO, NOTIFY YOUR INSURANCE COMPANY THAT YOU ARE INSTALLING YOUR WARNOCK HERSEY LISTED INSERT.
- GASOLINE OR OTHER FLAMMABLE LIQUIDS MUST NEVER BE USED TO START THE FIRE OR "FRESHEN-UP" THE FIRE. DO NOT STORE OR USE GASOLINE OR OTHER FLAMMABLE LIQUIDS IN THE VICINITY OF THIS APPLIANCE.
- THIS APPLIANCE MUST BE CONNECTED TO A LISTED HIGH TEMPERATURE RESIDENTIAL TYPE CHIMNEY OR AN APPROVED MASONRY CHIMNEY WITH A STANDARD CLAY, TILE, OR STAINLESS STEEL LINER.
- NEVER BLOCK FREE AIRFLOW THROUGH OPEN VENTS.
- ASHES MUST BE DISPOSED OF IN A METAL CONTAINER WITH A TIGHT FITTING LID, AND PLACED ON A NON-COMBUSTIBLE SURFACE BEFORE FINAL DISPOSAL.
- NEVER TRY TO REPAIR OR REPLACE ANY PART OF THE APPLIANCE UNLESS INSTRUCTIONS ARE GIVEN IN THIS MANUAL. ALL OTHER WORK SHOULD BE DONE BY A TRAINED TECHNICIAN.
- DO NOT MAKE ANY CHANGES OR MODIFICATIONS TO THE APPLIANCE OR AN EXISTING MASONRY FIREPLACE OR CHIMNEY TO INSTALL THIS APPLIANCE.
- WAIT UNTIL THE APPLIANCE HAS COOLED BEFORE CARRYING OUT MAINTENANCE PROCEDURES.
- TRAVIS INDUSTRIES, INC. GRANTS NO WARRANTY, IMPLIED OR STATED, FOR THE INSTALLATION OR MAINTENANCE OF YOUR APPLIANCE, AND ASSUMES NO RESPONSIBILITY FOR ANY CONSEQUENTIAL DAMAGE(S).
- ALWAYS FOLLOW THE INSTRUCTIONS IN THE OWNER'S MANUAL.
- KEEP THIS MANUAL FOR LATER USE.
- DO NOT CONNECT THIS APPLIANCE TO ANY CHIMNEY SERVING ANOTHER APPLIANCE.
- KEEP FURNITURE, DRAPES, CURTAINS, WOOD, PAPER AND OTHER COMBUSTIBLES A MINIMUM OF 36" AWAY FROM THE APPLIANCE.

IMPORTANT INFORMATION

INTRODUCTION.....	1
SAFETY PRECAUTIONS.....	2
FEATURES AND SPECIFICATIONS.....	4
CHIMNEY INFORMATION & REGULATIONS.....	5
The 3-Foot, 2-Foot, 10-Foot Rule.....	5
Factory-Built Chimneys.....	6
Determining the Distance Between the Chimney and Combustibles.....	6
Masonry Chimneys.....	7
OPTIONAL EQUIPMENT.....	8

INSERT INSTALLATION

PREPARATION FOR INSTALLATION - MASONRY INSERT.....	11
FIREPLACE INSERT - SPECIFICATIONS.....	13
MASONRY FIREPLACE INSERT INSTALLATION.....	15
Installation Using a Direct Connection.....	15
Installation Using a Positive Connection.....	17
Installation Using a Face Seal Connection.....	19
INSTALLATION OF A FIREPLACE BLOCK-OFF PLATE.....	20

OPERATING YOUR APPLIANCE

Location and Use of Controls.....	22
Burning Procedure.....	23
Burning Your Appliance Efficiently.....	24
Daily Use of Your Appliance.....	24
Wood.....	25
Seasoning Wood.....	26
Storing Wood.....	28

CARE AND MAINTENANCE

CARE AND MAINTENANCE.....	31
Maintenance Schedule.....	31
Maintenance Instructions.....	31

BEFORE CALLING FOR SERVICE

BEFORE CALLING FOR SERVICE.....	34
---------------------------------	----

REPLACEMENT PARTS AND REMOVAL INSTRUCTIONS

Replacement Parts.....	35
Removal Instructions.....	35
5-YEAR WARRANTY.....	42
SAFETY LABEL.....	43

FEATURES AND SPECIFICATIONS

- * EPA Phase II Approved **CONVENIENT**
 - * Large Firebox Capacity - 2.5 cu. ft. **HIGH HEAT OUTPUT**
 - * 3/16, 1/4 and 5/16" Steel Plate Construction **VERSATILE**
 - * Long Burn time - Up to 12 Hours **CLOSE CLEARANCES**
 - * Heavy Duty Firebrick Lining **DURABLE**
 - * Conveniently Located Single Push-Pull Combustion Air Control
 - * 22" Log Length Capacity
-

Heating Capacity	1,500 to 2,250 sq. ft.
Maximum B.T.U.'s/hr	75,300 (Cord Wood)
Overall Efficiency	70.3 % (Oregon Method)
Emissions Grams/hr	7.4 (EPA Method)
Maximum Burning Time (Hours).....	10 to 12
Flue Opening Diameter	6 in.
Height from Floor to Top of Appliance	22 1/2 in.
Overall Width in Fireplace	29 3/8 in.
Overall Depth in Fireplace	17 1/8 in.
Fuel.....	Solid Wood Only
Weight.....	345 lbs.

Emissions, Efficiency, Heating Capacity and Burn Times may vary depending on actual home floor plan, type of fuel used, and moisture content of wood. Emissions and efficiency numbers are those that have been certified by the U.S. E.P.A. and the Oregon Department of Environmental Quality.

CHIMNEY INFORMATION & REGULATIONS (Cont.)

Factory-Built Chimneys

Depending on the manufacturer and where the chimney is to be installed, special supports, roof assemblies, radiation shields, or locking bands may be supplied as a part of the chimney system. The manufacturer's installation instructions, which are reviewed by the listing agency, specifies when and where each of these components must be used.

There are three standard installations with factory-built chimneys. Each type of installation should use flashing and an adjustable storm collar at the roof line to prevent water from entering the house. Manufacturers require that chimneys extending beyond a certain height above the roof (frequently above 5 feet) must also be braced.

A chimney cap keeps out rain, birds and other animals, and may reduce down drafts. Spark arresters, wire mesh devices designed to catch sparks and burning particles emitted with the smoke, may be included with factory-built chimney caps. These spark arresters may become encrusted with creosote, blocking the proper flow of flue gases out of the chimney. When burning wood, it is recommended that the spark arrester be cleaned regularly, or removed entirely unless individual conditions or local codes require their use.

Determining the Distance Between the Chimney and Combustibles

The chimney must be kept a minimum distance of 2" away from combustibles (e.g., drywall, wood framing, etc.). The distance between the outside surface of a chimney and combustibles is measured horizontally, at right angles to the chimney. The pitch of the platform (e.g., the roof) must be considered in calculating the size of the hole that is cut.

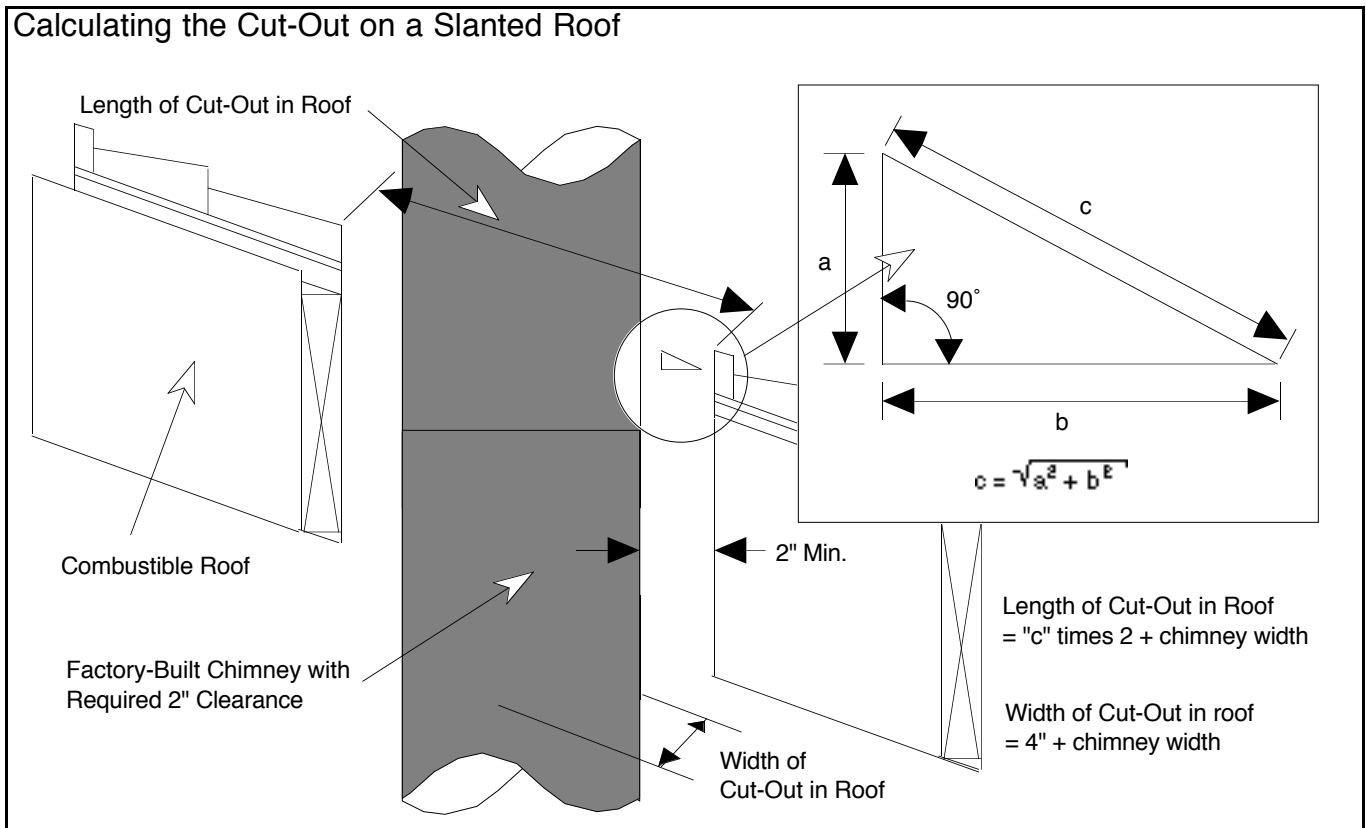

CHIMNEY INFORMATION & REGULATIONS (Cont.)

Determining the Distance Between the Chimney and Combustibles (Continued)

Installers may find it convenient to create hole cut-out templates for pitches common to their area rather than performing the calculations or using a trial "cut and measure" system for each installation.

Carefully read the specifications, as minimum clearances other than 2 inches are sometimes required by the manufacturer. Maintain a minimum clearance of 2" or what the manufacturer requires, **whichever is greater**.

Masonry Chimneys

If you are going to use an existing masonry chimney for your wood heating appliance make sure the chimney is inspected and found in good and safe condition. If the existing chimney is not in good condition repairs should be made before installation.

WARNING:

Do not connect this unit to a chimney flue serving another appliance.
Do not use makeshift compromises in the installation.

OPTIONAL EQUIPMENT

Your Flush Bay 96 comes assembled and only needs the blower attached. The options available for the appliance are listed below and require some assembly.

1. Surround Panels - 8", 10", and 12" Sizes (Includes Insulation)
2. Surround Panel Brass Trim (Included with Surround Panels)

1. Surround Panels

The surround panels for your insert are sold separately and come in the three sizes listed below. It is very important that you choose the surround panels that will adequately suit your installation. For direct or positive connections the surround panels do not require insulation for an airtight seal. For face seal connections the surround panels must overlap the fireplace at least 2" on the top and sides and require insulation to insure an airtight seal.

SURROUND PANEL SIZES SIZE ON APPLIANCE (INCLUDING TRIM)

8"	45 1/2" width by 29 3/4" height
10"	49 1/2" width by 31 3/4" height
12"	53 1/2" width by 33 3/4" height

NOTE: For a Face Seal Connection it is recommended that you have at least 2" of overlap. On brick or stone facing an overlap of 2 1/2" may be necessary for an airtight seal due to the rough surface.

It is very important that your surround panels overlap the fireplace opening by 1/4" or more. This will insure a good seal and provide a more attractive facade. When determining your surround panel size, remember that the panels must overlap the fireplace opening in both width **and** height. The surround panels may overlap the fireplace opening by more than the 1/4" recommendation if it is to allow for a complete seal. Any questions on selection of the surround panels should be directed towards your dealer. To install the surround panels, first refer to the type of installation you are using (e.g. Face Seal Connection, Direct Connection, etc...). Follow the directions listed for the type of installation you are doing, and follow the directions below when they are referred in that section.

1. The insert should be placed one foot away from the hearth to install the surround panels. After the side surround panels are installed, the insert can be placed into position. To mount the right side panel, you will first need to attach two of the metal clips. Slide the clips over the inward holes on the right panel so that the threaded side will be facing towards the insert when it is installed. See the illustration on the following page.
2. Carefully position the right side panel by making it angle backwards then sliding it into the appropriate location. Make sure to keep the metal clips in place while placing the panel in position. The inside portion portion of the panel bent at 90 degrees will fit behind the sheet metal that makes up the right side of the insert. See the illustration on the following page.
3. Attach the right side panel to the insert by screwing the two screws into the metal clips through the holes on the right side of the appliance. Tighten the screws enough to pull the panels against the insert.
4. Repeat steps 1 through 3 for mounting the left side panel.
5. Slide the top panel into place, making sure to align it properly over the two side panels.
NOTE: If using a positive or direct connection, the top panel should be installed after the flue is connected to the appliance.

OPTIONAL EQUIPMENT (Continued)

ATTACHING THE METAL CLIPS TO THE LEFT SIDE PANEL

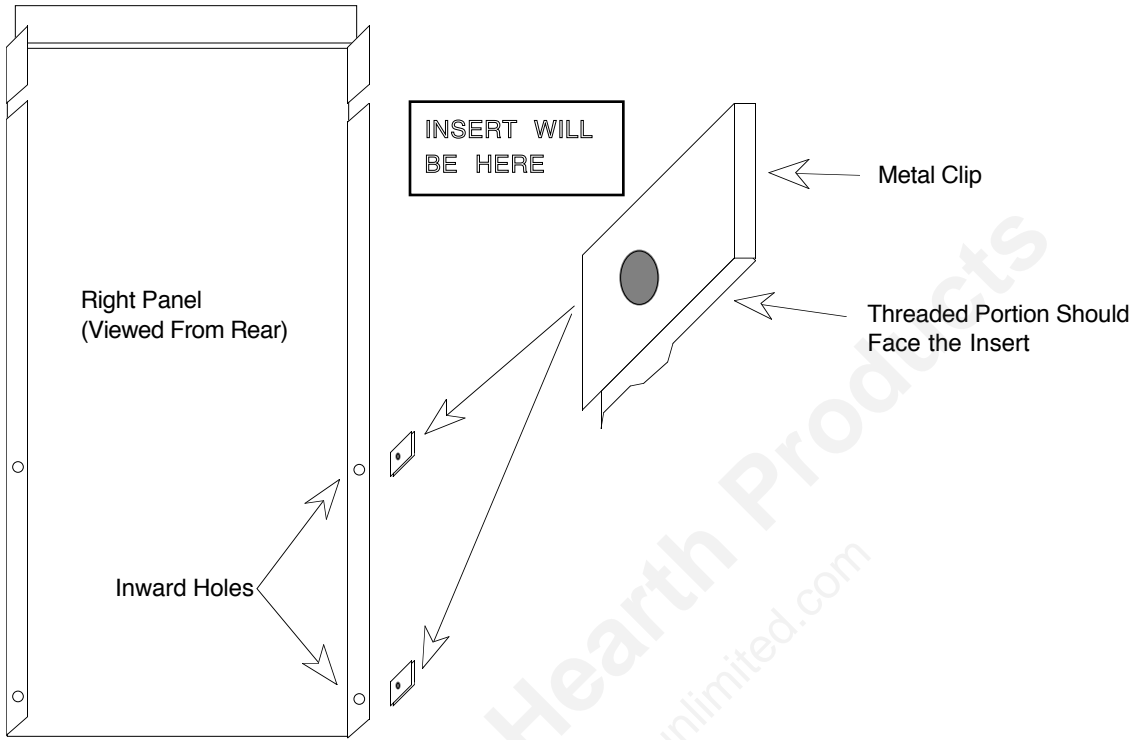

#1 - Rotate the Panel Back

#2 - Slide into Position

#3 - Rotate the Panel Forward

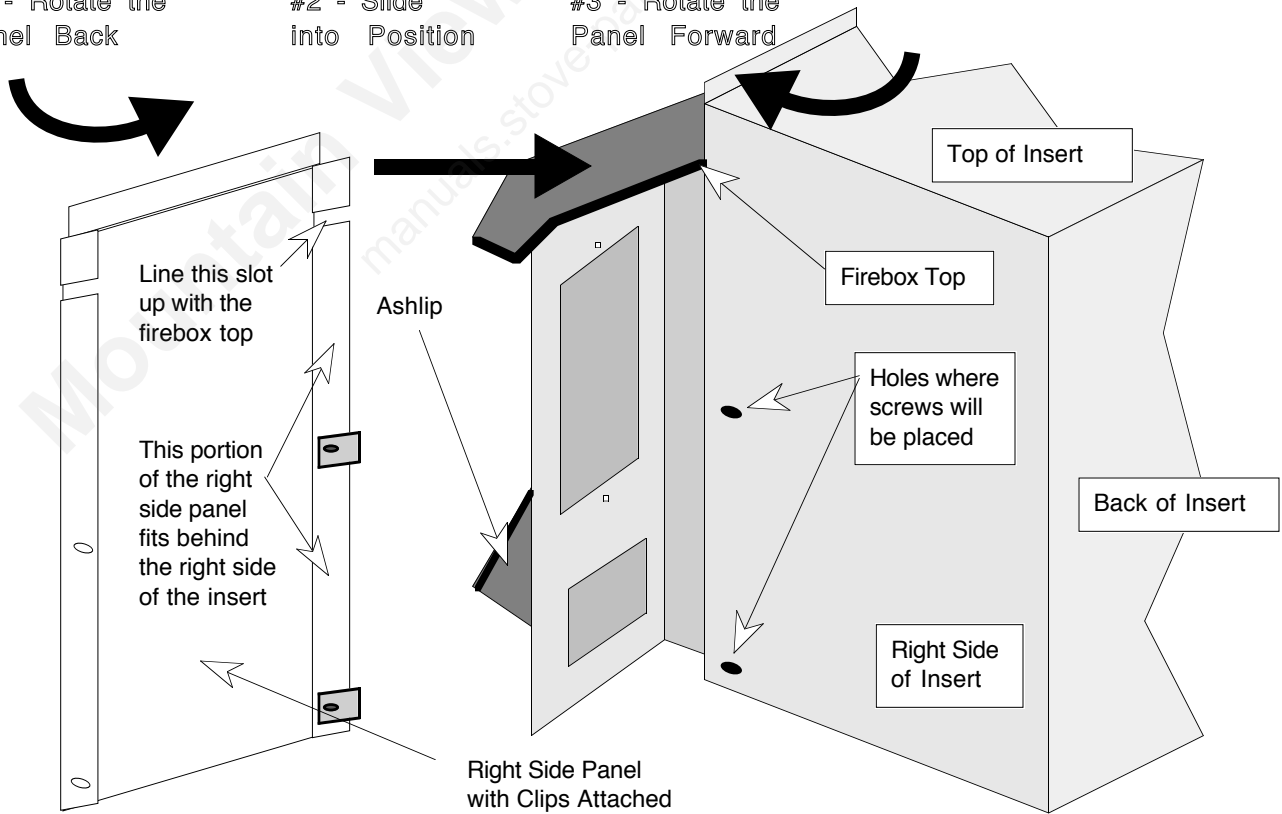

OPTIONAL EQUIPMENT (Continued)

SURROUND PANEL INSULATION INSTALLATION

Insulation is required for the surround panels if you are installing the insert with a face seal connection. The direct and positive connections do not require surround panel insulation.

1. Position insert approximately 6" from the face of the fireplace and glue the insulation to the back of the panels to match the fireplace opening. Fiberglass wool insulation strips are used to make the seal between surround panels and the face of the fireplace. NOTE: When installing the brass trim, refer to the brass trim installation section before continuing.
2. Push insert in until seal is made against the face of the fireplace. Be careful not to scratch your hearth.
3. Make sure insert is square in fireplace opening. Use a screwdriver to tuck any exposed insulation behind the panels. Check for a good seal by running a match around the perimeter of the facing panel to determine if any drafts are occurring. If so, fill the spot with more insulation and recheck.

2. Surround Panel Brass Trim

The surround panel brass trim is an item included with your panels that greatly enhances the appearance of your insert and is easy to install.

To install the trim, first remove the trim from the packaging and lay it on the floor so each piece has the front side facing down (it is slightly rounded – see the cross section below). The piece that will fit on the top is the longest with bevels on both ends. To determine the left from the right side, find the end that is beveled and place it so its bevel touches the bevel of the top piece. The three pieces should form an upside-down "U" with a bevel between each separate piece.

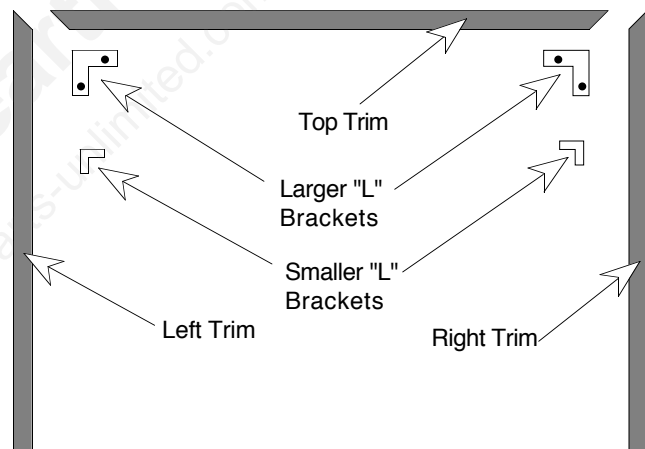

Next, take one of the two larger "L" brackets and insert it into the slot in the left side of the top brass trim. Take the left side brass trim and insert it into the other end of the larger "L" bracket. Do the same thing with the smaller "L" bracket. Make sure the top and side brass trim align properly. Insert two of the four set-screws included with the brass trim package into the larger "L" bracket and tighten. This will hold the left brass trim to the top. Repeat these steps for the right trim. With the three pieces of brass trim assembled together, slide the entire brass trim onto the finished surround panels from the top down. Make sure it goes all the way on and fits flush with the bottom of the surround panels.

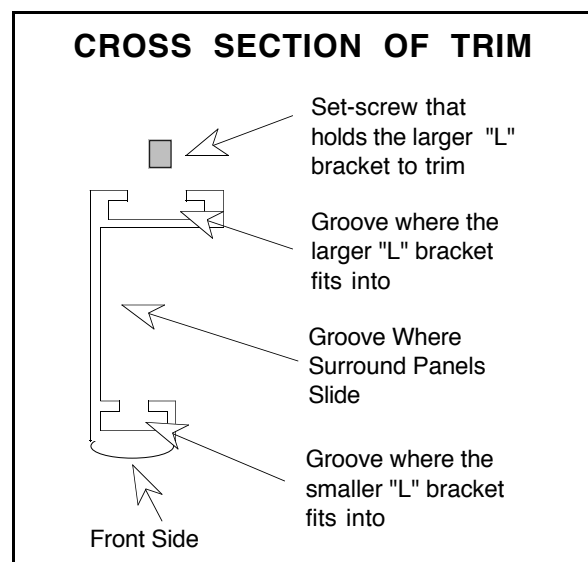

PREPARATION FOR INSTALLATION - MASONRY FIREPLACE INSERT

READ THIS ENTIRE MANUAL BEFORE YOU INSTALL AND USE YOUR NEW APPLIANCE. FAILURE TO FOLLOW INSTRUCTIONS MAY RESULT IN PROPERTY DAMAGE, BODILY INJURY, OR EVEN DEATH.

PREPARATION:

1. Remove all tape and packaging.
2. Remove the wood shipping frame from around and under the appliance.
3. Check that no parts have become loose and the appliance has not been damaged during shipping.
4. Remove the hardware pack from the appliance.
5. **READ THE OWNER'S MANUAL BEFORE PROCEEDING.**

- * Appliance should be located such that no doors, drapes, furniture or other combustibles can be placed close or swing closer than the minimum 36" clearance.
- * The appliance must be installed in a level, secure position.

REQUIRED FLOOR PROTECTION:

NOTE: Minimum hearth extension of 45 3/8" width by 18" depth from fireplace opening is required.

CHIMNEY LENGTH	Maximum	Minimum
Vertical	33 Feet	15 Feet

OPTIONS

Your fireplace insert comes completely assembled. Options available for your fireplace insert are:

1. Surround Panels - 8", 10", and 12" Sizes
2. Surround Panel Brass Trim (Included with Surround Panels)

SAFETY

For your safety, examine the fireplace and chimney prior to installation of the insert to determine that they are free from cracks, loose mortar, creosote deposits, blockages, or other signs of deterioration. If evidence of deterioration is noted, the insert should not be installed until after repairs have been made. Any opening between the masonry of the fireplace and the facing masonry must be permanently sealed. Your fireplace insert is listed for installation into masonry fireplaces, and is approved to be installed with one of the following connections:

1. Positive
2. Direct
3. Face Seal

NOTE: It is recommended your chimney have a minimum 28 and a maximum of 144 square inch cross-sectional area to use a face seal connection, otherwise your chimney may not have sufficient draw for the fireplace insert to operate correctly. If your chimney does not fit within these parameters it is recommended you install a direct or positive connection.

When lifting the appliance, you may choose to remove the interior components to make it lighter. Refer to the section "REPLACEMENT PARTS AND REMOVAL INSTRUCTIONS" for the proper sequence of removal and replacement of internal components.

PREPARATION FOR INSTALLATION - MASONRY FIREPLACE INSERT

INSTALLING THE BLOWER

1. Locate the box containing the blower which is shipped with the flush bay insert.
2. Remove the blower from the box and check for damage that may have occurred during shipping.
3. Remove the two hex head screws from the face of the appliance. See the illustration below.
4. Place the blower under the ashlip and align the two slots in the back mounting bar with the two holes in the face of the appliance.
5. Insert one of the screws in each hole. Pull the blower assembly up as far as it will go to eliminate any space between the blower and ashlip.
6. Tighten both screws securely.
7. Insert the plug into a grounded outlet.

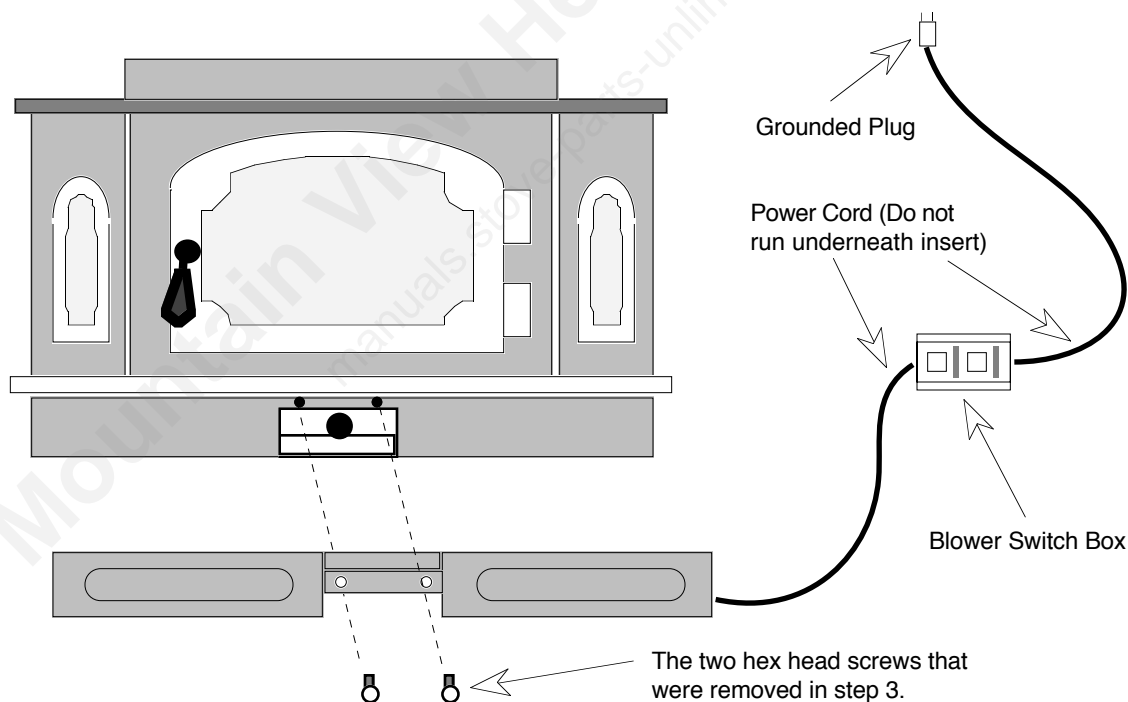

NOTE: Do not run the power cord underneath or in contact with the insert.

FIREPLACE INSERT - SPECIFICATIONS

LOCATION OF FLUE COLLAR DIMENSIONS REQUIRED FOR INSTALLATION INTO FIREPLACE AND PANEL SIZING.

TOP VIEW

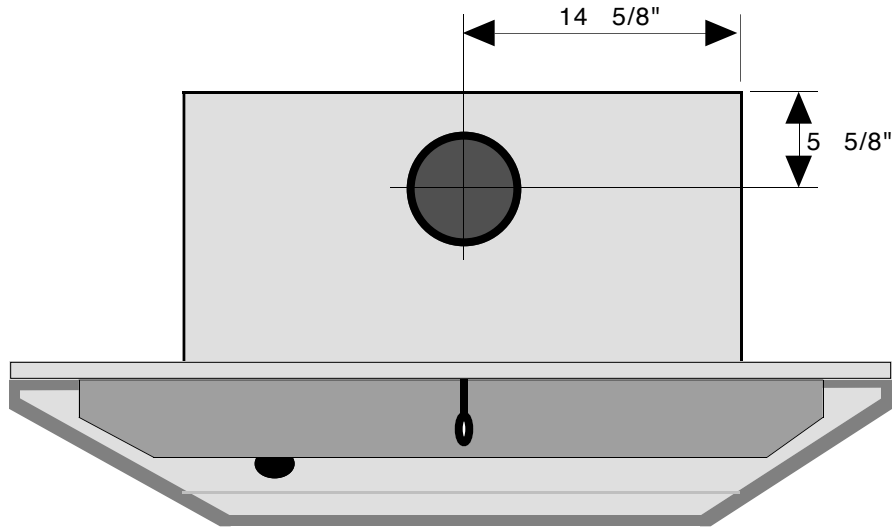

FIREPLACE SIZING

Measure and center the insert into the fireplace based on the provided measurements.

- A. Minimum Height (Front) 22 1/2"
- B. Minimum Height (Back) 22 1/2"
- C. Minimum Width (Front) 29 3/8"
- D. Minimum Width (Back) 29 3/8"
- E. Depth into Fireplace 16 1/2"
- F. Extension onto Hearth (From Face of Fireplace) 4 3/4"

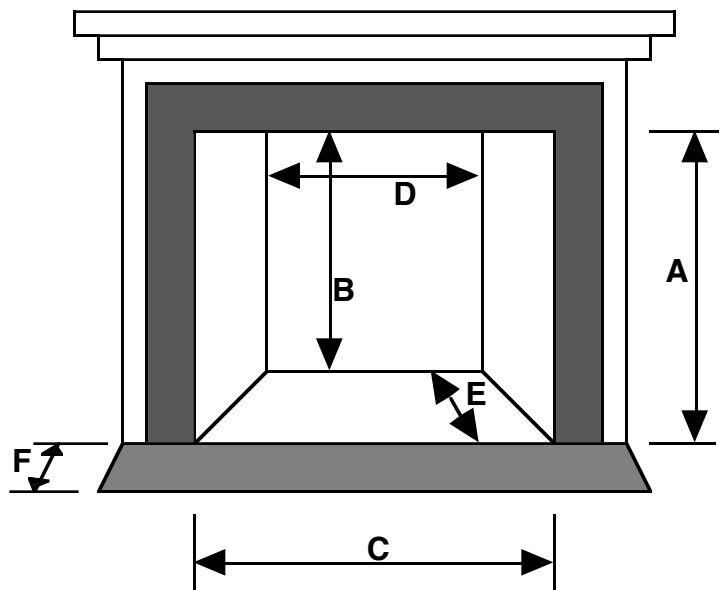

FIREPLACE INSERT - SPECIFICATIONS (Continued)

FLOOR PROTECTION:

Hearth of 45 1/4" width and 18" depth when the insert is in place (see "E" and "F" below).

CLEARANCE TO COMBUSTIBLES:

A. Adjacent Sidewall to Insert	15"
B. Side Facing	13 1/2"
C. Top Facing With Shield	30" 17"
D. Mantle to Insert With Shield	32" 19"
E. Minimum Floor Protection-Front	18"
F. Minimum Floor Protection-Side	8"

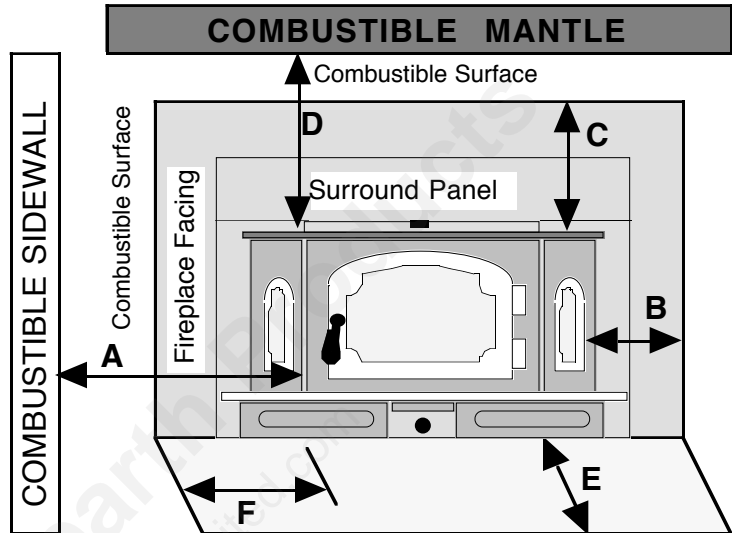

NOTE: For clearances, use this clearance diagram or the clearance diagram on the safety label attached to the back of the appliance.

LEVELING BOLTS

If your fireplace is stepped down from the hearth, you will be required to use the leveling bolts located within the hardware package.

Prior to placing the insert in the fireplace opening, measure the step-down. Screw the 1/2" bolts provided into the threaded holes in the back corners of the insert body and adjust them to match the step-down measurement. As you install the insert the leveling bolts may need further adjustment. This may be done by tilting the insert slightly and turning the bolts.

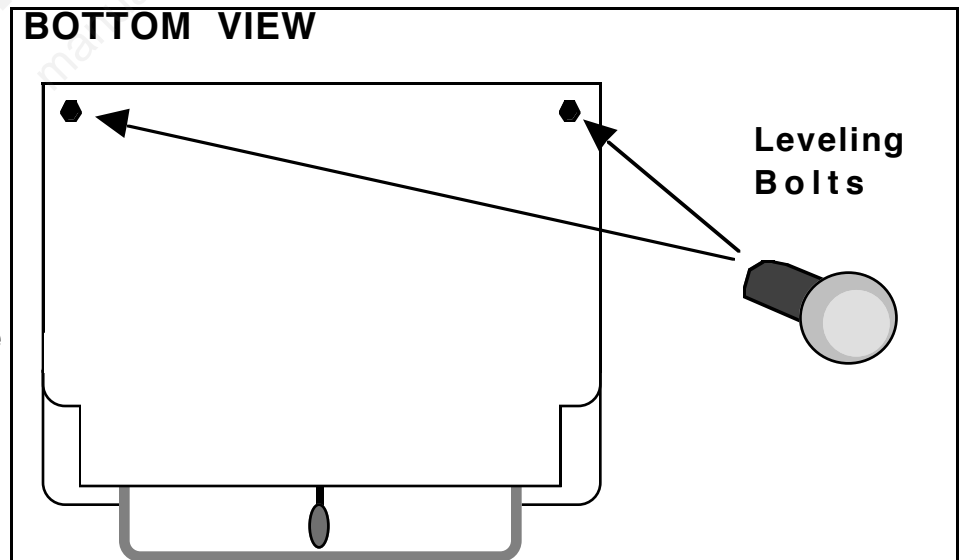

MASONRY FIREPLACE INSERT INSTALLATION

Installation Using a Direct Connection

Using the direct connection between your insert and masonry chimney allows you to use your existing chimney with a minimum of installation work. An airtight seal must be made with a block-off plate to insure that your chimney will draw the smoke out of the appliance. The directions below illustrate one way to install your insert into a direct connection masonry chimney. There are other alternative methods. Check with your dealer or installer for information on other options available to you. The directions below should be followed in the order listed.

1. Inspect the masonry chimney and follow all the rules outlined in the section titled "CHIMNEY INFORMATION & REGULATIONS".
2. Follow the directions for making a block-off plate in the section titled "INSTALLATION OF A FIREPLACE BLOCK-OFF PLATE".
3. Follow all of the regulations and guidelines specified in the sections titled "FIREPLACE INSERT - SPECIFICATIONS" and "PREPARATION FOR INSTALLATION - MASONRY FIREPLACE INSERT".

4. Once the plate is in position, slide the pipe into the plate up through the damper. It **must** extend up to the flue liner or at least one foot past the block-off plate.
5. Install the surround panels by following the directions in the section titled "OPTIONAL EQUIPMENT". You may now place your new appliance into the fireplace opening and position the connector pipe so that it can be easily pushed into the flue opening on top of the insert. You may want to use a towel or blanket to protect the floor while positioning the insert.

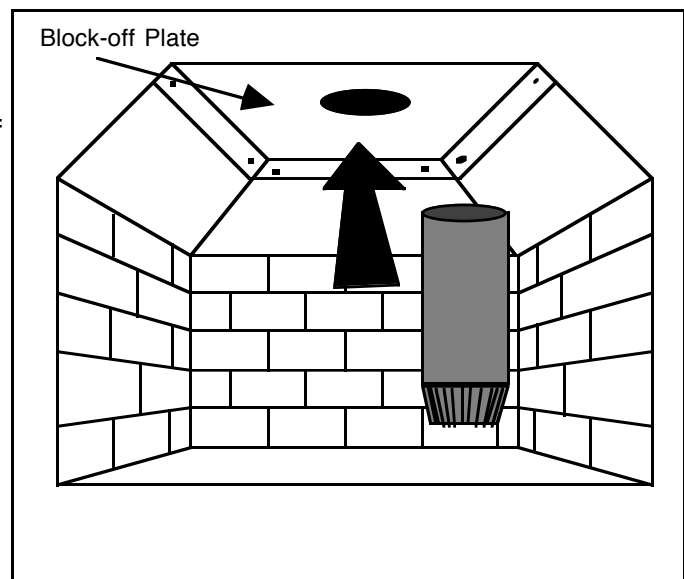

6. Once this has been accomplished, reach in and pull the connector pipe down into the flue of the insert. If ample room between the top of the insert and the fireplace opening does not exist, you will need to remove the top firebricks by following the directions in the section "REPLACEMENT PARTS AND REMOVAL INSTRUCTIONS". Then reach inside the appliance and pull the connector down by placing your hand up through the flue opening of the appliance. The chimney connector should fit tight and secure into the flue opening.
7. With the connector in place, you have now completed the direct connection for your insert. It is a good idea to check your connection by trying to rock the chimney connector back and forth. If it feels snug, a good connection is established. If you can feel some play when you rock it back in forth, make sure that the insert is properly aligned and that the connector fits tight into the flue collar on the top of the insert.
8. Take a look at the figure on the following page. Make sure all of the items listed are complete.

MASONRY FIREPLACE INSERT INSTALLATION (Cont.)

Installation Using a Direct Connection (Continued)

Follow the installation instructions in reverse order for periodic inspection and cleaning.

SIDE VIEW OF FIREPLACE INSERT DIRECT CONNECTION

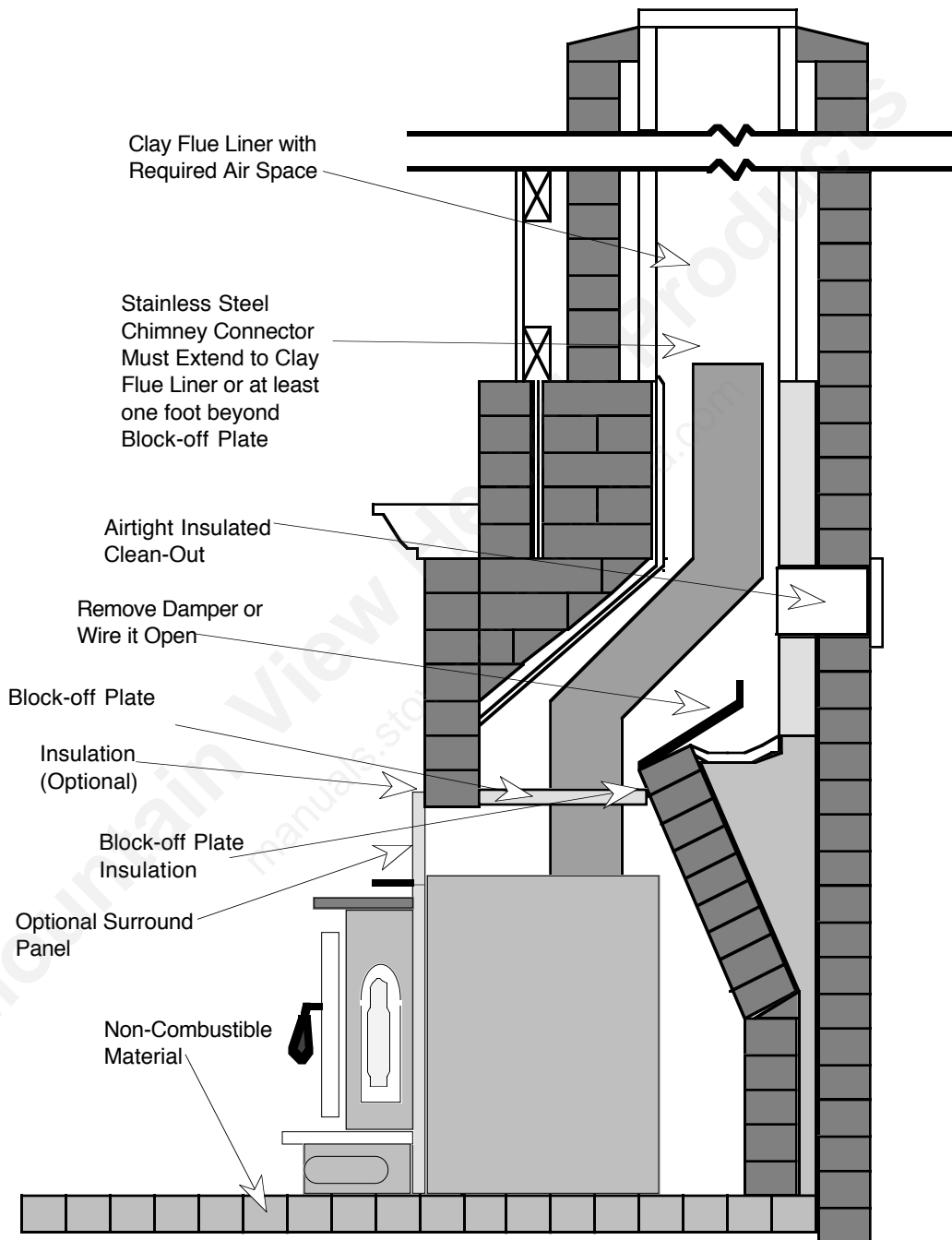

Follow the directions on the previous page for installation.

MASONRY FIREPLACE INSERT INSTALLATION (Cont.)

Installation Using a Positive Connection

Using a positive connection between your insert and masonry chimney allows you to use your existing masonry chimney to support a new factory-built chimney liner. The advantages of a positive connection are excellent chimney draft and ease of cleaning. A block-off plate is not needed for this type of installation because the positive connection provides sufficient draft. If one is used, it need not be airtight. The directions below illustrate one way to install your positive connection. There are several other alternative methods. Check with your dealer or installer for information on other options available to you.

1. Install the positive connection (full reline) through the masonry chimney according to the manufacturer's instructions for installation and support. Make sure to follow all of the manufacturer's safety precautions during assembly. Inspect the masonry chimney and positive connection so that all of the rules outlined in the section titled "CHIMNEY INFORMATION & REGULATIONS" are met.
2. If a block-off plate is desired (optional), follow the directions for making a block-off plate in the section titled "INSTALLATION OF A FIREPLACE BLOCK-OFF PLATE".
3. Follow all of the regulations and guidelines specified in the sections titled "FIREPLACE INSERT - SPECIFICATIONS" and "PREPARATION FOR INSTALLATION - MASONRY FIREPLACE INSERT".

4. If you are using a block-off plate, slide the pipe into the plate up through the damper. If you are not using a block-off plate, make sure the last segment of the positive connection will reach the insert once it is inserted into the fireplace.
5. Install the surround panels by following the directions in the section titled "OPTIONAL EQUIPMENT". You may now place your insert into the fireplace opening and position the connector pipe so that it can be easily pushed into the flue opening on top of the insert. You may want to use a towel or blanket to protect the floor or panel finish while positioning the insert.

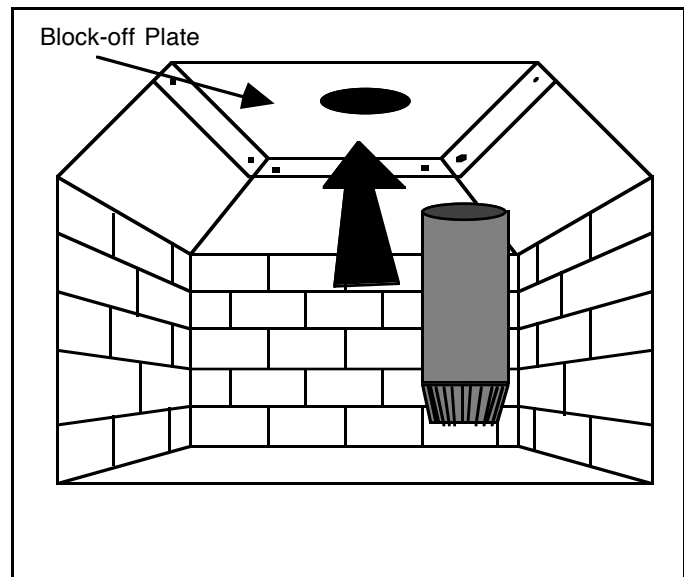

6. Once this has been accomplished, reach in and pull the connector pipe down into the flue of the insert. If ample room between the top of the insert and the fireplace opening does not exist, you will need to remove the top firebricks by following the directions in the section "REPLACEMENT PARTS AND REMOVAL INSTRUCTIONS". Then reach inside the appliance and pull the connector down by placing your hand up through the flue opening of the appliance. The chimney connector should fit tight and secure into the flue opening.
7. With the connector in place, you have now completed the positive connection for your insert. It is a good idea to check your connection by trying to rock the chimney connector back and forth. If it feels snug, a good connection is established. If you can feel some play when you rock it back in forth, make sure that the insert is properly aligned and that the connector fits tight into the flue collar on the top of the insert.

MASONRY FIREPLACE INSERT INSTALLATION (Cont.)

Installation Using a Positive Connection (Continued)

8. Take a look at the figure below. Make sure all of the items listed below are completed.

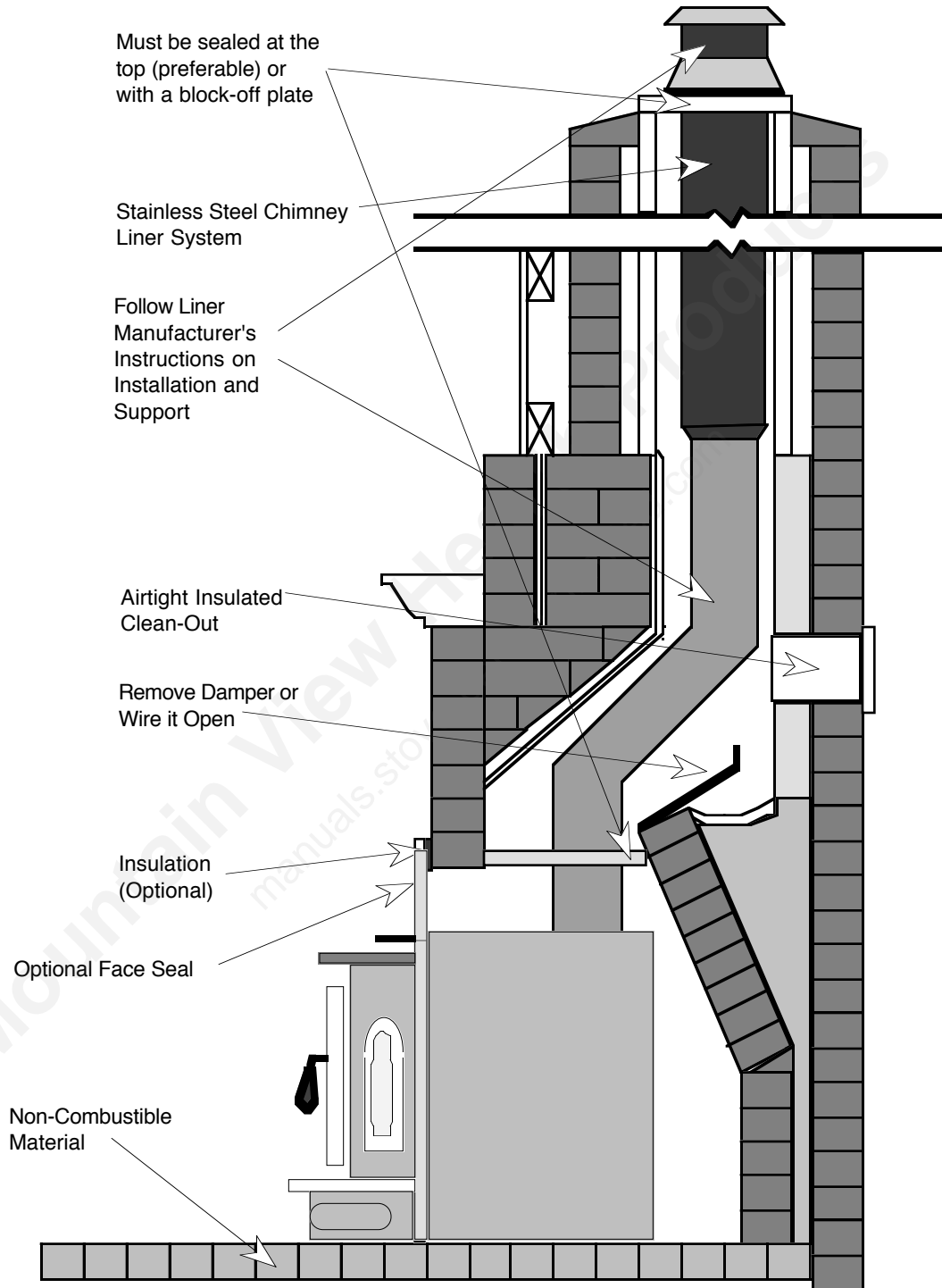

Follow the installation instructions in reverse order for periodic inspection and cleaning.

MASONRY FIREPLACE INSERT INSTALLATION (Cont.)

Installation Using a Face Seal Connection

NOTE: It is recommended your chimney have a minimum 28 and a maximum of 144 square inch cross-sectional area to use a face seal connection, otherwise your chimney may not have sufficient draw for the fireplace insert to operate correctly. If your chimney does not fit within these parameters it is recommended you install a direct or positive connection.

Using a face seal connection allows you to use your existing masonry chimney with your new insert. The advantages of a face seal connection are ease of installation and low cost. The directions below illustrate the way to install a face seal connection with your insert.

1. Inspect the masonry chimney to make sure the fireplace meets all of the rules outlined in the section titled "CHIMNEY INFORMATION & REGULATIONS". Make sure the fireplace and chimney are thoroughly cleaned and in good condition.
2. Follow all of the regulations and guidelines specified in the sections titled "FIREPLACE INSERT - SPECIFICATIONS" and "PREPARATION FOR INSTALLATION - MASONRY FIREPLACE INSERT".
3. Wire open or remove the fireplace damper
4. Follow the directions specified in the section titled "SURROUND PANEL INSTALLATION" for installation of the panels **and** the insulation. Insulation between the surround panels and the facing of the fireplace is required.
5. Take a look at the figure below. Make sure all of the items listed are completed.

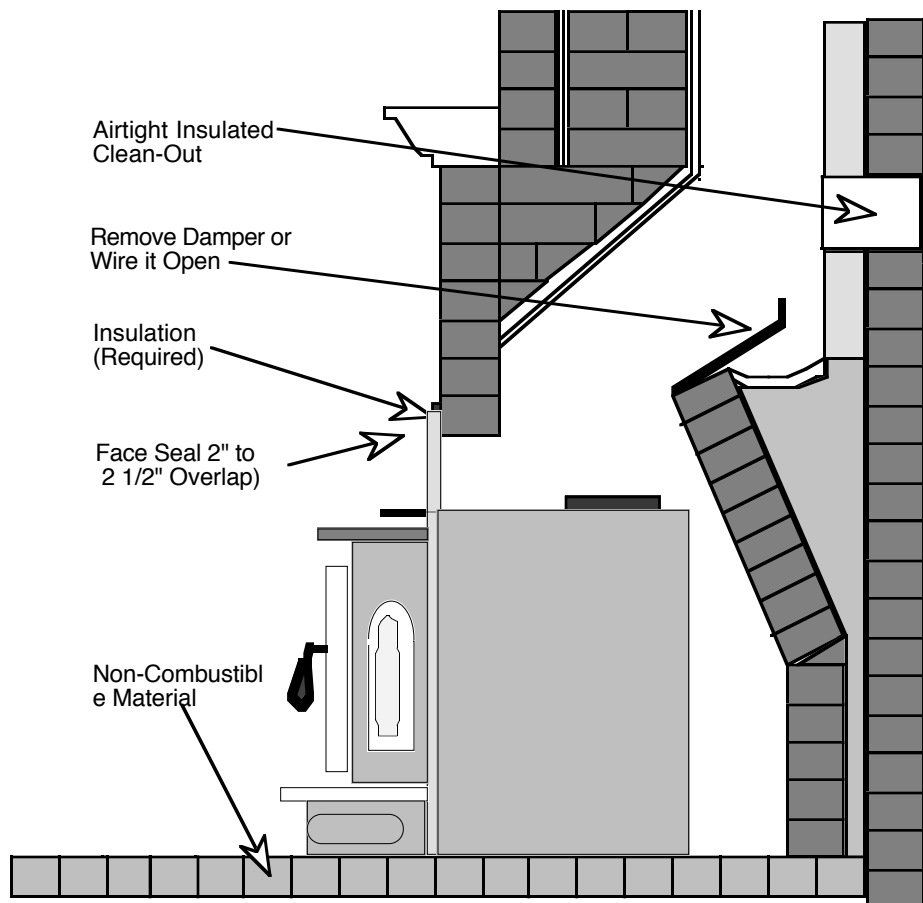

Follow the installation instructions in reverse order for periodic inspection and cleaning.

INSTALLATION OF A FIREPLACE BLOCK-OFF PLATE

A block-off plate is used to prevent the exhaust going into a masonry fireplace from entering the inside of the house. It ensures a tight seal between the masonry fireplace and the stove pipe leading through it. A properly made block-off plate, coupled with either a positive or direct connection, provides the wood heating appliance with a vacuum draw that pulls the flue gases out of the appliance and out the top of the chimney. The directions below show how a block-off plate is made.

1. Measure below damper area the width from side to side at rear of smoke chamber. Label this Measurement "A".
2. Measure the width below damper area from side to side at front of smoke chamber. Label this Measurement "B".
3. Measure the depth below damper front to back of smoke chamber. Label this Measurement "C".
4. Make a template of your measurements, but add 2" to each of the sides.

CROSS SECTION OF FIREPLACE

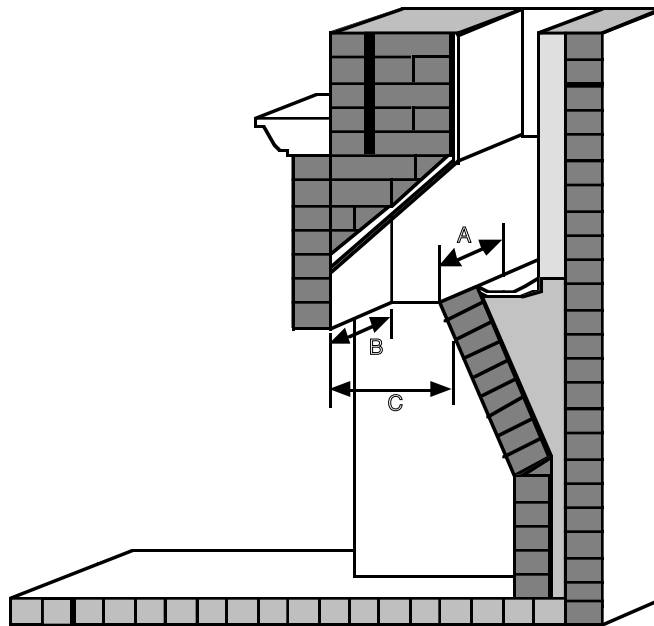

Your template should resemble the drawing on the next page with the dotted lines indicating your initial measurements and the solid line indicating the additional 2". You will use this template to cut a piece of sheet metal (minimum 24 gauge) to install in your smoke chamber.

The solid line will represent the shape of the piece of sheet metal cut while the dotted line will represent where you will bend the sheet metal for installation. Mark the position of several holes on each side to suit your specific installation, and drill 1/4" diameter holes.

INSTALLATION OF A FIREPLACE BLOCK-OFF PLATE (Continued)

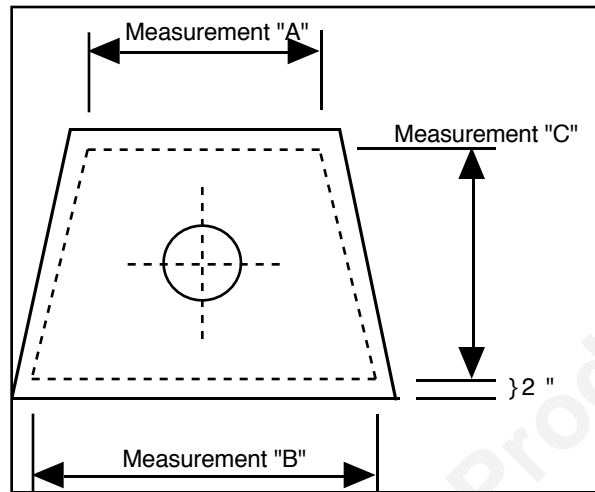

5. Bend the sheet metal as indicated on the template at a 45 degree angle on each side after cutting the sheet metal (This 2" lip will allow you to screw this plate into the smoke chamber inside your fireplace). The 2" lip with the 1/4" diameter holes will allow you to screw the plate to the firebox walls.
6. Determine the position of where to cut the 6-1/4" hole in the sheet metal plate so that it lines up with the chimney flue opening and the final position of the wood burning appliance, then cut the hole. If you are installing surround panels with your insert, refer to the section "SURROUND PANEL INSTALLATION" for how to position your insert correctly.
7. Put the plate in position and drill the mounting holes. Then bolt into position using the mounting bolts. The seal can be completed by using fiberglass insulation and/or furnace cement between the masonry and the block-off plate.

NOTE: Allow the furnace cement to cure for 12 to 24 hours before starting a fire.

OPERATING YOUR APPLIANCE

Location and Use of Controls

Combustion Air Control

The Combustion Air Control is located in the center under the ashlip and is operated by pushing or pulling the control. When the control is completely pushed in, it is in the fully open position. When it is completely pulled out, it is in the fully closed position.

Bypass Damper Control

The bypass Damper Control is located on the center top of the appliance, and is operated also by pushing or pulling the control. When pulled out all the way, it is in the fully open position. When pushed in all the way, it is in the fully closed position.

NOTE: The Bypass Damper Control becomes very hot during operation and should only be controlled with the operating tool provided.

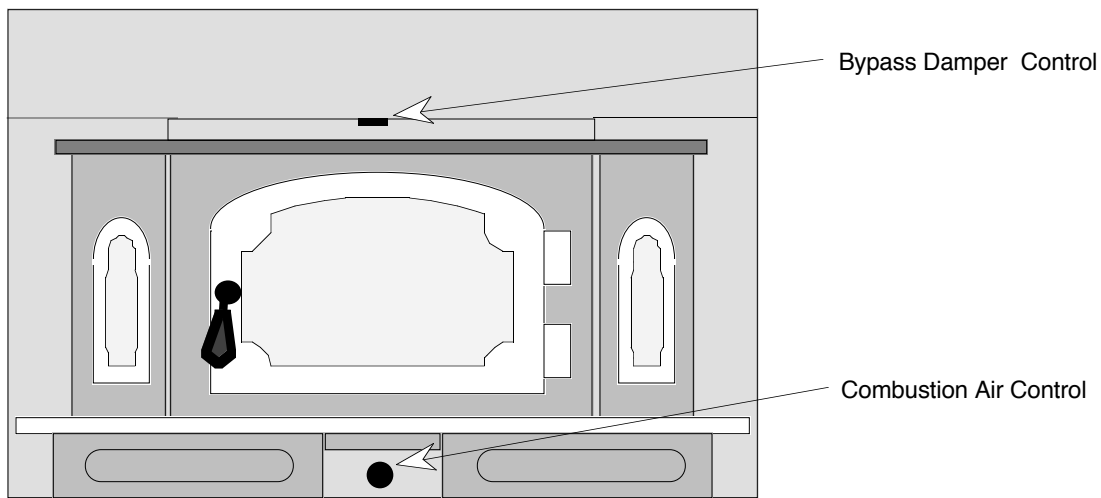

Blower Controls

The blower controls are located on the switch box that is connected by a cord to the blower. There are two rocker switches that determine the speed and mode (automatic or manual) of the blower. The two speeds are RUN (slower) and STARTUP (faster). The two modes are AUTO (appliance will detect heat and turn the blower on when the insert is hot) and MAN (manual – the blower will run on the speed setting selected).

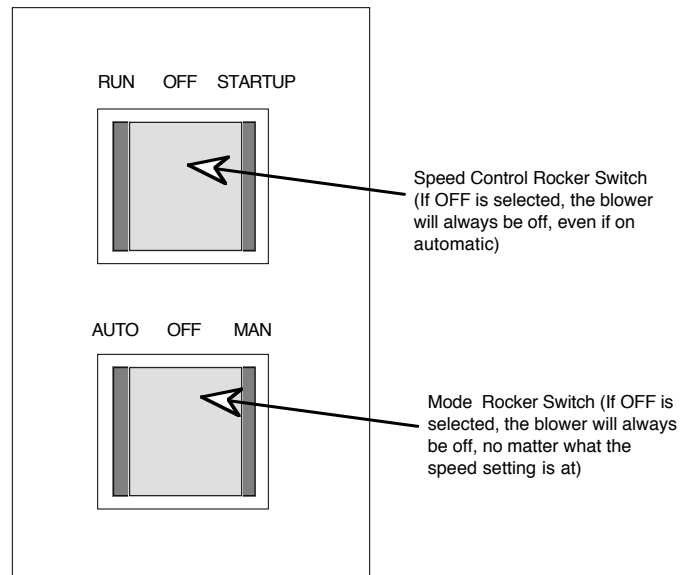

OPERATING YOUR APPLIANCE (Continued)

To build a fire in disregard of the information provided in this section can cause permanent damage to your appliance and void your warranty.

This appliance is not designed for use with the door open. Burning with the loading door open could create a safety hazard.

Burning Procedure

1. Open the door and place some paper and kindling or a solid, wax impregnated firestarter inside the appliance.
2. Make sure that the combustion air intake control is fully open by pushing the control knob all the way in. Open the bypass damper control, located on the top center of the appliance, by pulling it all the way out.
3. Now light the fire. Once the kindling is burning, add some small dry pieces of wood and close the loading door and the bypass damper. NOTE: The first two or three fires in your new appliance will cause the high temperature paint to give off a slight odor and a small amount of smoke. This is the paint curing. For best results during the curing of the paint, burn small intense fires so the appliance does not overheat. The high temperature paint cures best at medium temperatures. Also, the viewing glass may become somewhat obscured the first few times, as your appliance is drying all moisture from bricks and even the steel itself.
4. Next add two or three medium size dry logs (use of green or wet wood in your appliance will develop creosote, cloud glass, and greatly decrease its efficiency). At this time establish a hot fire with a bed of red hot coals.
5. To slow the rate of burn, you can close (pull out) the combustion air intake control (lower center of the appliance) as needed.
6. The bypass damper should be opened only when starting a fire, and when reloading the appliance.

NOTE: Over-restricting the amount of combustion air into the appliance will cause creosote build-up on glass and in the appliance and flue. This will also greatly decrease the efficiency of the appliance.

Do not open the door of your appliance when the air control inlet is fully closed. There is a possibility with a solid fuel burning appliance that doing so could result in a sudden flash of flames as the fire ignites with oxygen. However, your LOPI has been thoroughly safety tested to reduce this possibility.

If your home is a new, airtight energy efficient home, you may have to supply an outside air inlet to prevent possible air starvation to appliance.

OPERATING YOUR APPLIANCE (Continued)

Burning Your Appliance Efficiently

Your Lopi Flush Bay 96 is designed to heat your home efficiently with the lowest amount of creosote build-up and pollutants emitted. The following steps provide a guideline to efficient burning:

On cold days, when you wish for high heat output from your appliance, load the appliance fully after the fire has been established and burn at a medium-high to high burn mode. When a comfortable heat level in your home has been reached, subsequent loadings would be of lesser amounts of wood. On warmer days, burn smaller fires, using less wood. This method will give you the most efficient burn possible.

Although the fire will burn longer at a lower setting, your appliance will not produce as much heat and it will increase soot accumulation on the appliance, chimney and glass.

For an overnight burn, establish a hot fire. Before you are ready to retire, completely fill the appliance with wood. With the controls in the fully open position, let the fire burn intensely for 20-30 minutes. Next adjust the draft control so that a low, lazy flame is visible. In the overnight burn, you should be able to maintain a fire for about 10-12 hours, depending on the type of wood used, and still have a coal bed, with no visible flame, left to start the morning fire. To re-establish a fire after an overnight burn, open the controls fully and stir the ashes to bring hot coals to the surface. Then follow the instructions under "first fire". If you dampen the fire down too low, you will not only lower the heat output, but you will be promoting creosote build-up. It will take a few days of practice to achieve the desired settings.

APPROXIMATE COMBUSTION AIR CONTROL SETTINGS

TYPE OF BURN RATE

AIR CONTROL SETTING

Overnight Burn	Fully Closed
Medium Burn	Open 1/16"
Medium High Burn.....	Open 1/8" to 3/8"
High Burn	Fully Open

Daily Use of Your Appliance

During daily use of your appliance you will learn what rates of burn best accommodate your heating needs. A stove thermometer is highly recommended. Approximate low burn is 300 degrees F., approximate medium burn is 500 to 600 degrees F. and approximate high burn is 800 degrees F. with the thermometer located on the top of the appliance.

Some helpful hints: After loading your appliance, open the air control and allow your appliance to burn vigorously for 20 to 30 minutes. This will assist in the burn-off of any creosote which accumulates over periods of extended use at low settings.

OPERATING YOUR APPLIANCE (Continued)

Wood

This appliance is designed to burn natural wood only. Higher efficiencies and lower emissions generally result when you burn air dried, seasoned hardwoods as compared to softwoods or to green or freshly cut hardwoods. **DO NOT BURN** treated wood, garbage, solvents, trash, coal, cardboard, colored paper, or wax impregnated logs (i.e. Duraflame, etc.). Burning treated wood, garbage, solvents, colored paper or driftwood from salt water may result in release of toxic fumes and may render the appliance ineffective and void the limited warranty. Burning coal, cardboard or loose paper can produce soot, large flakes, char or fly ash that can coat the inside of your appliance, causing smoke spillage into the room.

Choosing the kind of firewood to burn in your appliance depends on what is available to you. If all you can obtain is softwoods, obviously, that will be your choice.

Softwoods such as pine and fir are easily ignited and burn rapidly with hot flames. Since they burn so easily and quickly you will have to spend more time loading your firebox, especially in the high burn mode. With softwoods it will be much more difficult to achieve an overnight burn. Furthermore, softwoods make it necessary to reload the appliance more often. The chart below outlines the advantages of using hardwood.

SPECIES*	LBS./CORD**	BTU's/CORD**	Hours per Cord at 40,000 BTU's per Hour**
ALDER	2540	19,050,000	476
APPLE	4400	33,000,000	825
ASH	3440	25,800,000	645
BIRCH	3040	22,800,000	705
CEDAR	2060	15,450,000	386
COTTONWOOD	2160	16,200,000	405
DOGWOOD	4320	31,725,000	793
ELM	2260	16,950,000	423
FIR, DOUGLAS	2970	22,275,000	556
HEMLOCK	2700	20,250,000	506
MAPLE	3200	24,000,000	600
OAK, RED	3680	27,600,000	690
OAK, WHITE	4200	31,500,000	787
PINE	2250	16,875,000	421
REDWOOD	2400	18,000,000	450
SPRUCE	2240	16,800,000	420

* At 20% moisture content

** All values are approximate

If you have a choice it is best to use the more dense hardwoods for a longer lasting fire. The best arrangement is to have a mix of softwoods and hardwoods for ease of start-up and a longer lasting fire. Also, it is a good idea once the fire is established to use larger diameter logs stacked tightly together. This will promote a longer burn time.

Wood is typically sold by the "cord". A cord is a nicely stacked pile of logs measuring 4 feet wide by 4 feet high by 8 feet long. Always look for the driest wood especially if you purchase your wood by weight. Unseasoned, wet wood is much heavier.

Moisture content of the wood greatly affects the way any appliance operates. Well seasoned wood (split, stacked and kept dry for at least 12 months) is your best fuel choice.

OPERATING YOUR APPLIANCE (Continued)

Wood (Continued)

Wet wood not only causes more work for you due to the increase in weight making it more burdensome to carry, but most importantly it will not burn as efficiently. You will receive less heat output from a wet piece of wood because it wastes energy evaporating the water, energy that should be used for heating your home. When a wet piece of wood is placed in your appliance it will also cause more creosote accumulation on the glass, in the appliance, flue and chimney. The primary reason for this is, as the water evaporates from the wood it will "spit" creosote-like material. If you can hear your wood sizzle or you can see moisture bubbling from the ends of the logs placed in a HOT appliance, your wood is too wet! Another big advantage to burning seasoned wood, aside from higher efficiency and less creosote, is LESS POLLUTION!

Seasoning Wood

Green wood will burn, but seasoned or dry wood is lighter, has more heat value, and is less apt to form creosote deposits. Any moisture in the wood reduces the recoverable heat because water absorbs heat in the process of being changed to steam. The net heat from a pound of completely dry (no moisture) hardwood is about 7,950 BTU's. All wood has some moisture in it which reduces the net usable heat at a rate of 1,200 BTU's per pound of water.

The moisture in the wood of living trees varies among species, within a species, and even within individual trees. Frequently, there is a significant difference between the quantity of moisture contained in the central column of heartwood of a tree and the outer layers of sapwood which is surrounded with bark. For example, freshly cut American beech has been found to have a heartwood moisture content of 72%. In contrast, heartwood moisture contents in American elm, northern red oak, and white ash are 95, 80 and 46%, respectively.

When drying wood, the greater the surface area exposed to the air, the more rapid the drying. Therefore, stack the wood in loose piles that are raised off the ground. Wood greater than 8 inches in diameter or longer than 4 feet dries very slowly. Reduce the size of such sticks by splitting and/or sawing.

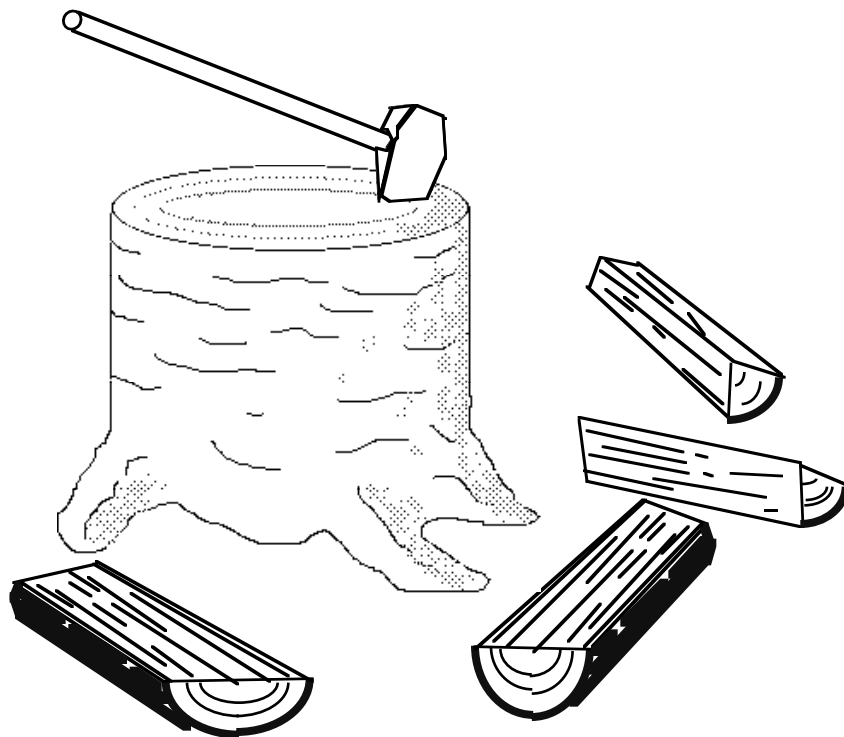

OPERATING YOUR APPLIANCE (Continued)

Seasoning Wood (Continued)

Place firewood in an open area to obtain rapid drying and to prevent deterioration. Preferably, put a cover on the top tier of wood. If you cut trees in summer, let them lie for a week. The leaves will draw moisture from the wood and dry it more quickly than if you limb the tree immediately.

Seasoning can be accelerated greatly by simply stacking fuelwood in a sunny location and then covering it with clear plastic sheeting. In sunny weather, temperatures within the plastic covering will rise much higher than outside, warming the wood and evaporating the contained moisture. The water vapor produced either escapes or condenses on the plastic covering; therefore some arrangement for ventilation is necessary. It is also desirable to hold the plastic away from the rough ends of the wood to prevent abrasion, allow air to flow, and keep any condensation from re-wetting the wood.

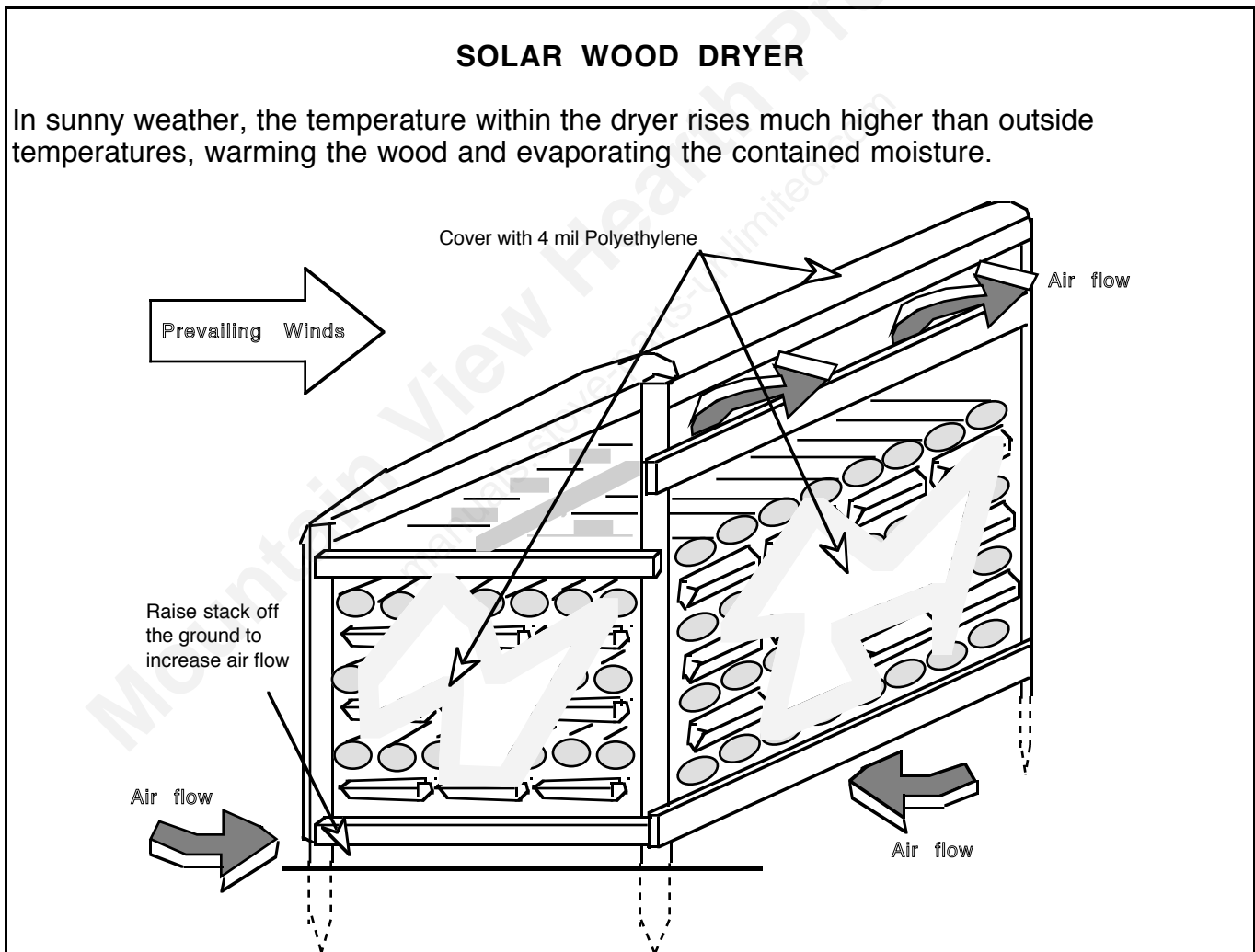

Many arrangements for plastic covering are possible. Thin 2 millimeter, clear polyethylene sheeting sold for drop cloths or garden mulching is not recommended because it is easily torn. The 4 millimeter thickness is more satisfactory and less costly than 6 millimeter. Any clear polyethylene deteriorates badly after a few months of exposure to full sunlight, so the stack may have to be re-roofed to remain dry over winter.

OPERATING YOUR APPLIANCE (Continued)

Seasoning Wood (Continued)

The bathroom scales can be used to check if firewood is still seasoning. Weigh a basket or bag of a few pieces of firewood. Place them back in the wood pile as an identified appliance. Then weigh them again in about a month. If they have lost weight, the wood is still drying. Cracks that appear in the end of logs are good signs that the wood is well seasoned.

Generally, wood that is 1) cut to length, 2) split, and 3) stacked in the open, preferably with a cover, during the winter, should be thoroughly seasoned by the next heating season.

Storing Wood

Firewood is best stored outdoors, under cover and near the house so that valuable space in the house is not used, insects are kept outside, and the dirt problem is reduced. Store the wood under cover to keep it dry and its fuel value high. It can be stored in a wood shed, utility building, garage or under a sheet of plastic or sheet metal roofing.

When drying wood, the greater the surface area exposed to the air, the more rapid the drying. Wood greater than 8" in diameter or longer than 4' dries very slowly. Reduce the size of such sticks by splitting and/or sawing. Be sure to keep an air space between the wood and any covering. Stack the wood in loose piles that are raised off the ground. This will promote air circulation that helps dry the wood.

TYPICAL WOOD SHED

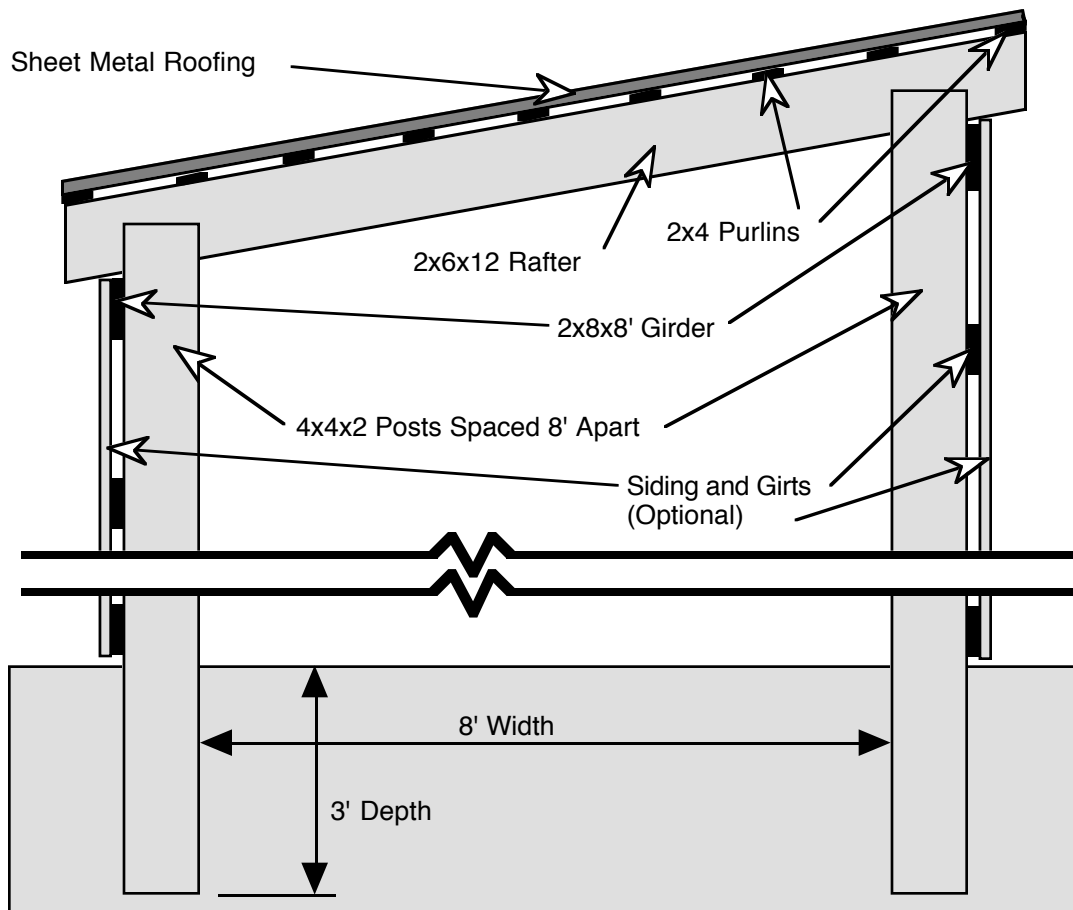

OPERATING YOUR APPLIANCE (Continued)

Storing Wood (Continued)

If sufficient space is available under a roof, seasoning and storage can be accomplished in one handling. This practice eliminates the extra handling of moving wood that has been dried outside into a covered storage area.

Outside, wood will dry to between 14 and 25% moisture content depending on humidity, temperature, and wind. In a garage or woodshed it may dry to between 10 and 15% moisture content; and wood may dry to between 5 and 12% in the house.

End braces can be used if you have difficulty stacking wood and if the pile collapses at either end. Constructed with two-by-fours, end braces are like book ends and can be built to accurately measure a standard cord. The boards beneath the woodpile keep the bottom row off wet ground.

In some homes a wood box can be constructed inside the house, convenient to the wood appliance and which has loading access outside. The access door to the wood box from the outside of the house should be tight fitting.

OPERATING YOUR APPLIANCE (Continued)

SAFETY IN OPERATION

The Following Safety Rules Should Be Followed Whenever Using Your Appliance:

- 1. Do not use this appliance for any purpose other than heating. Burn solid wood fuels only.**
- 2. Never use gasoline, gasoline-type lantern fuel, kerosene, engine oil, charcoal lighter fluid, or similar liquids to start or "freshen up" a fire. Keep all such liquids well away from the appliance while it is in use.**
- 3. Do not burn garbage in your appliance, or use chemicals or fluids to start the fire.**
- 4. Use caution when loading fuel into the appliance after it is already burning vigorously.**
- 5. Do not over-fire the appliance at any time. If the appliance glows red, it is over-fired.**
- 6. Keep all household combustibles and appliance fuel at least 3 feet from the appliance at all times. Store fuel in a dry place well away from the appliance.**
- 7. Do not support or elevate the fire off of the firebrick. Burn the fire directly on the bricks. Do not use a grate.**
- 8. Educate your children of the dangers associated with fire and the presence of a hot appliance. Touching a radiating surface can cause serious burns. Child guards are available through your dealer.**
- 9. Keep loading door closed at all times except to load fuel.**
- 10. Avoid placing logs and fire against viewing glass.**
- 11. Maintain the door and glass seal and keep them in good condition.**
- 12. Do not modify your combustion air control to allow more air into your appliance.**
- 13. Do not burn any kind of coal in this appliance.**
- 14. Do not slam door or strike glass.**

CARE AND MAINTENANCE

Maintenance Schedule

The following schedule should be followed to insure your appliance stays in peak condition.

Weekly Maintenance: The following should be done once a week:

ASH DISPOSAL
BRASS CLEANING
GLASS CLEANING

Bi-Monthly Maintenance: The following should be done every two months:

CHECK FOR CREOSOTE
DOOR AND GLASS GASKET INSPECTION
LUBRICATE THE DOOR HINGE AND CONTROLS

Yearly Maintenance: The following should be done after each heating season:

FIREBRICK REMOVAL AND CLEANING
APPLIANCE TOUCH-UP
BLOWER CLEANING (If Applicable)

Maintenance Instructions

ASH DISPOSAL

During constant periods of use ashes must be periodically removed from the appliance to prevent a build-up which will affect the performance and limit the fuel load capacity.

Ashes should be placed in a metal container with a tight fitting lid. The closed container of ashes should be stored on a non-combustible floor or on the ground, well away from any combustible material, pending final disposal. If the ashes are to be disposed of by burial in soil or otherwise locally dispersed, they should be retained in the closed container until all cinders have thoroughly cooled. Other waste must not be placed in this container.

BRASS CLEANING

Your appliance may come with a solid brass door, ashlip trim and panel trim, which will require periodic attention to retain its luster. Use a non-abrasive polish, such as "FLITZ" on the solid brass door and clean it only when it is cool. A suitable polish is available at your dealer. The brass ashlip and panel trim should only be cleaned with soap and water. The use of ANY type of brass polish will damage the finish.

GLASS CLEANING

Clean the glass only when the appliance is cool, using a non-abrasive cleaner. If glass cracks or breaks, let the appliance cool before replacing it. **DO NOT OPERATE THE APPLIANCE WITH BROKEN OR MISSING GLASS. IF THE GLASS DOES BREAK, FOLLOW THE DIRECTIONS IN THE SECTION TITLED "REPLACEMENT PARTS AND REMOVAL INSTRUCTIONS" FOR REPLACING THE GLASS.**

CARE AND MAINTENANCE (Continued)

DOOR AND GLASS GASKET INSPECTION

A damaged or deteriorated glass or door gasket will allow air to enter the appliance through the space between the door and firebox. This will allow smoke to enter the room and hamper efficient burning. Inspect the door gasket to make sure it is flexible and completely intact. Any torn, broken, or flattened gaskets should be replaced by following the directions in the section titled "REPLACEMENT PARTS AND REMOVAL INSTRUCTIONS".

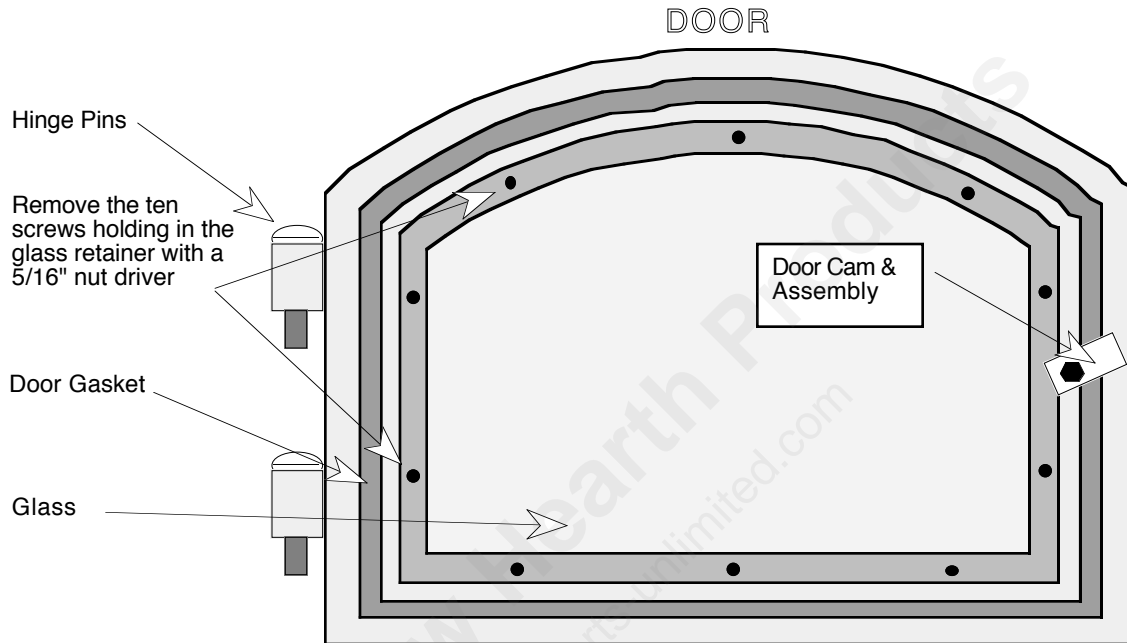

LUBRICATE THE DOOR HINGE AND CONTROLS

It is highly recommended that you periodically lubricate any moving parts such as the door hinges, combustion air control and bypass damper control rods. This will eliminate any scraping or squeaking noises as well as allow the parts to move freely. A high temperature lubricant, such as Permatex Industrial (R) Anti-seize lubricant, is required. Graphite or low-temperature lubricants will only last a few days.

CHECK FOR CREOSOTE

Creosote is a tarry liquid or solid resulting from the distilling of wood during the combustion process. Using wet wood or burning at lower temperatures will result in a heavier creosote deposit. Creosote vapors will condense in a relatively cool chimney flue of a slow burning fire. As a result, creosote residue accumulates on the interior surface of the chimney and flue pipes, considerably reducing their diameter. When ignited, this creosote makes an extremely hot and dangerous fire. The chimney should be inspected at least once every 2 months during the heating season to determine if a creosote build-up of approximately 1/4" has accumulated. If this is the case, the creosote should be removed to reduce the risk of a chimney fire.

Most problems with creosote are due to poor chimneys with low draft and/or cold walls, and to a low rate of burn when little heat is needed during the spring and fall months. Burning green and resinous wood also creates creosote.

To prevent creosote accumulation

1. Burn your appliance with the combustion air control wide open for 20 to 30 minutes daily during the burning season. This will burn out creosote deposits in your appliance.

CARE AND MAINTENANCE (Continued)

CHECK FOR CREOSOTE (Continued)

2. Burn the appliance with the combustion air control wide open for about 20 minutes every time you add fresh wood. This allows the wood to achieve the charcoal stage faster and burns the wood vapors which might otherwise be deposited within the system.
3. Burn only seasoned, dry wood. Seasoned wood is wood that has been dried for at least one year.
4. A small, more intense fire is preferable to a large smoldering one that will deposit creosote within the system.
5. Establish a routine for using your new appliance. Be aware that the hotter the fire, the less creosote is deposited on the glass and chimney system. Weekly inspection and cleaning may be necessary during times of heavy appliance usage. Contact your local fire authority for information on how to handle a chimney fire. Have a clearly understood plan to handle such a fire.
6. We recommend that you have your chimney system and appliance checked and cleaned by a competent chimney sweep twice a year.

FIREBOX INSPECTION AND CLEANING

At the end of each heating season, remove all of the ash inside the firebox and check for any scale that may have built up during the heating season. Remove any scale from the inside of the firebox with a wire brush or scraper. With a flashlight check to see that all of the firebrick lining the firebox is in good condition. If any of the firebrick is cracked or broken, follow the directions in the section titled "REPLACEMENT PARTS AND REMOVAL INSTRUCTIONS" for removal and replacement of any damaged firebrick.

APPLIANCE TOUCH-UP

The outside of the appliance can be touched up using high temperature "Forrest Stove-Brite" paint, available at your dealer. This will improve the looks of your appliance, but is not necessary. To touch up paint, first sand the area to be painted with 120 grit sandpaper, clean it with water only, and dry with a clean cloth. Paint using light covering coats. The newly painted area will appear darker until the paint goes through the curing process.

BLOWER CLEANING

You should remove your blower from the appliance at least twice a year for cleaning. Dust will accumulate on the blower cover as well as the blower motor and impellers. These parts should be cleaned to insure adequate flow of air and minimize strain on the motor.

BEFORE CALLING FOR SERVICE

SAVE TIME AND MONEY - CHECK THIS LIST BEFORE YOU CALL FOR SERVICE

To eliminate unnecessary service calls, first read all the instructions in this manual carefully. The following checklist provides possible solutions to common occurrences that are not the result of defective workmanship or materials in this appliance.

If you do have a problem that you cannot fix yourself, call the dealer where you purchased your appliance. When calling, have this manual handy with the model, serial number and purchase date of your appliance.

Problem	Possible Cause	Don't Call for Service Until You Check
Start-up fire extinguishes itself.	<ul style="list-style-type: none"> • Combustion air inlet blocked. • Combustion air control closed. 	<ul style="list-style-type: none"> • Combustion air inlet is not blocked. • Combustion air control is open.
Lazy orange smoky flame.	<ul style="list-style-type: none"> • Bad Fuel. • Restricted Flue. • Poor Draft. 	<ul style="list-style-type: none"> • Wood is dry & seasoned. • Chimney is clean & unrestricted. • Sufficient chimney length & correct size.
Smoke smell inside house.	<ul style="list-style-type: none"> • Restricted chimney or reverse flow (down draft). • Air leak from faulty door or glass gasket. • Door is out of adjustment. 	<ul style="list-style-type: none"> • Chimney is clean & unrestricted. • Chimney is not receiving a down draft due to wind or other obstruction. • Door and glass gasket are in good condition and sealing properly. • Door is aligned with the opening so the door gasket makes an airtight fit around the opening.
Appliance won't shut down.	<ul style="list-style-type: none"> • Air leak from faulty door or glass gasket. • Door is out of alignment. 	<ul style="list-style-type: none"> • Door and glass gasket are in good condition and sealing properly. • Door is aligned with the opening so the door gasket makes an airtight fit around the opening.

REPLACEMENT PARTS AND REMOVAL INSTRUCTIONS

Several components inside your appliance are serviceable by you. These components are usually easy to remove and replace without special tools. Before you attempt to carry out any of these steps, be sure to read through the entire section. To order new parts, use the chart below to order the appropriate part number through your dealer. Use only parts from your dealer made specifically for your appliance.

Replacement Parts

Part Name	Part Number	Part Description
Door Gasket	90-1512	7/8" Dia. Round Fiberglass
Glass Gasket	90-1496	3/8" Flat Fiberglass
Door Glass	90-1421	19 1/8" x 10 1/4"
Firebrick (note size)	90-4000	1 1/2" x 4 1/2" x 9"
Secondary Air Tubes	90-5000	Two Tubes, 21 1/4" Long
Front Baffle Support Angle ("Y" Bar)	90-5030	22" Long
Rear Baffle Support Angle ("T" Bar)	90-5031	22" Long
By-Pass Damper Adjustment Tool	90-2010	
Door Handle	90-2052	Brass Spring
Air Control Handle	90-2059	Brass Spring
By-Pass Damper Handle	90-2012	
Owner's Manual	92-3001	
Cast Glass Retainer	90-2020	
Air Control/Plate with Springs	90-2060	

Removal Instructions

The remaining text in this section details the items below. Make sure to follow the directions closely when performing one of the procedures. If re-assembly directions are not given with the instructions, re-assemble by following the directions in reverse order. All of these procedures can be done without special tools.

- Removing and Replacing the Glass
- Removing and Replacing the Glass Gasket
- Removing and Replacing the Door Gasket
- Removing and Replacing the Firebricks
- Removing and Replacing the Secondary Air Tubes

REPLACEMENT PARTS AND REMOVAL INSTRUCTIONS (Continued)

Removing and Replacing the Glass

DO NOT OPERATE THE APPLIANCE WITH BROKEN OR MISSING GLASS. IF THE GLASS DOES BREAK, FOLLOW THE DIRECTIONS BELOW FOR REPLACING THE GLASS.

To replace the glass, first remove the door cam assembly by removing the nut with a 9/16" wrench. Then remove the ten screws holding in the glass retainer with a 5/16" nut driver. Replace only with Neoceram 5mm thick, available from your dealer.

Unscrew the ten screws on the glass bracket with a 5/16" nut driver. Pull the glass retainer, glass, and glass gasket away from the door. Replace the glass with Travis Industries Inc. replacement glass (available at your dealer). The replacement glass is high temperature, high shock ceramic glass. When re-installing, make sure the gasket is properly aligned ..

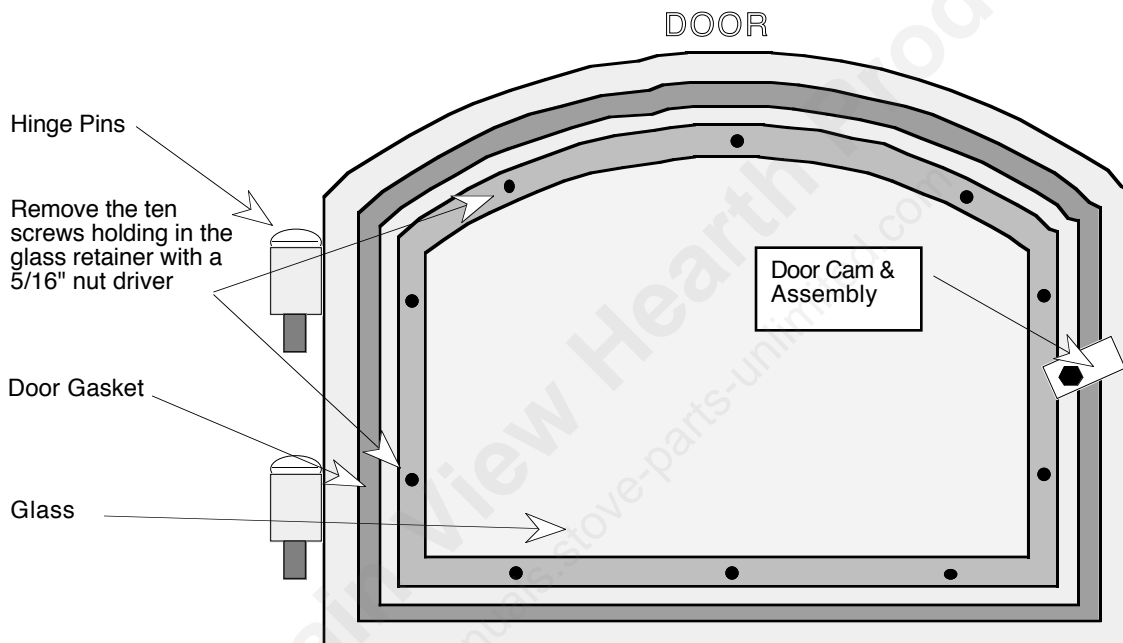

Removing and Replacing the Glass Gasket

A damaged or deteriorated glass gasket will allow air to enter the appliance through the space between the door and glass. This may cause smoke to enter the room and hamper efficient burning. To replace the glass gasket, follow the directions for removal of the glass and when re-installing, place the new gasket in place.

Removing and Replacing the Door Gasket

A damaged or deteriorated door gasket will allow air to enter the appliance through the space between the door and firebox. This will allow smoke to enter the room and hamper efficient burning. The door gasket is held in place with special cement made to withstand extreme heat. To remove the gasket, carefully pull the gasket away from the door and scrape any excess cement off the door. To replace, use the manufacturer's gasket and cement (provided by your dealer) and re-attach the gasket, making sure it is aligned properly around the opening.

REPLACEMENT PARTS AND REMOVAL INSTRUCTIONS (Continued)

Removing and Replacing the Firebricks

The firebricks inside your wood-burning appliance are used to store the radiating heat and create a more thorough combustion inside the firebox. Occasionally one of them will crack and require replacement. The directions below are divided into three sections, each section addressing either the baffle (top) firebricks, side and back firebricks, or floor (bottom) firebricks. Before any bricks are removed, make sure the appliance is cool and cleaned out. The chart below describes the number and size of bricks by placement.

# of Firebricks	Full Size (9" by 4 1/2" with a 1 1/4" thickness)	Half Size (4 1/2" by 4 1/2" with a 1 1/4" thickness)	Cut Size (4 1/2" by 7" with a 1 1/4" thickness)
Floor (bottom)	7	1	
Side and Back	11		
Baffle (top)	6		1

REMOVING THE FLOOR (BOTTOM) FIREBRICKS

1. Make sure the appliance is cool and cleaned out.
2. Remove the door by opening it 90 degrees and pulling it upwards. Make sure to grasp the door by both ends. It is heavy and can be damaged easily.
3. Remove the center forward firebrick by lifting its front top edge (see illustration below). Do not use any object to pry the firebrick, for this may cause the firebrick to chip or crack.
4. Remove the rest of the front bricks, one by one, following the order listed in the illustration to the right. Remove the rear bricks in the order listed.
5. To replace the floor firebricks, follow these directions in reverse order, placing the bricks snug against the firebricks lining the side of the firebox.

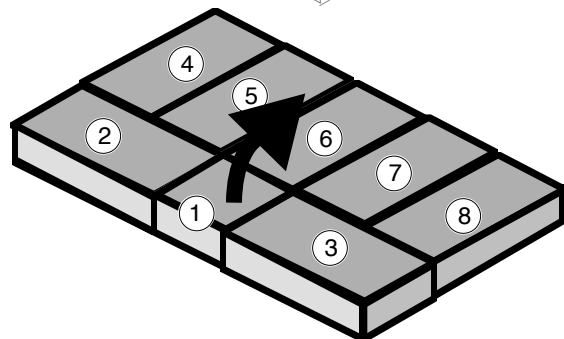
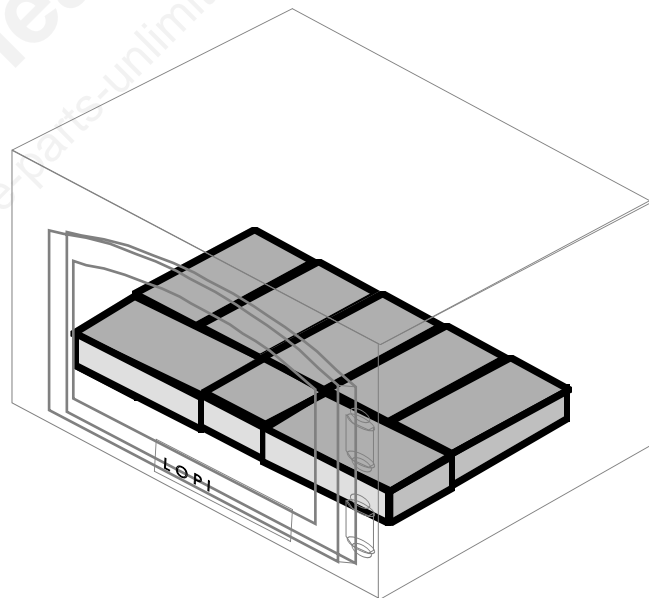

REPLACEMENT PARTS AND REMOVAL INSTRUCTIONS (Continued)

Removing and Replacing the Firebricks (Continued)

REMOVING THE SIDE AND BACK FIREBRICKS

1. Follow the directions for removing the floor firebricks.
2. Once the bottom firebricks are removed, the side and back firebricks can be pivoted out from behind the metal clips that hold the firebricks in place. Grasp the bricks, one at a time, from the bottom and pivot them out from the bottom. See the diagram to the right to see the order of removal.
3. To replace the side and back firebricks, follow these directions in reverse order, placing the bricks snug against each other and against the walls of the firebox.

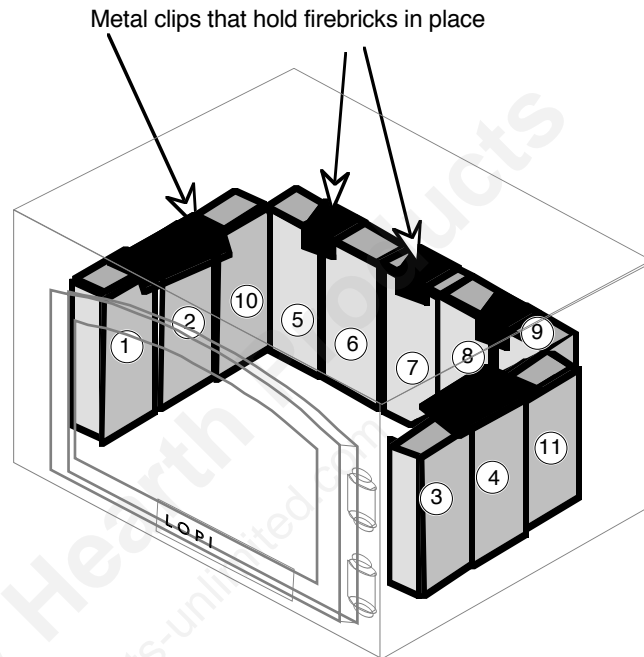

REMOVING THE BAFFLE (TOP) FIREBRICKS & COMPONENTS

1. Make sure the appliance is cool and cleaned out.
2. Remove the door by opening it and pulling it upwards. Make sure to grasp the door by both ends. It is heavy and can be damaged.
3. Take a close look at the exploded view for this section (two pages down). Note the position of the Front Baffle Angle (referred to as the "Y" Bar). It must be lifted and rotated to expose the first line of firebricks. Note the drawing titled "Rotating the Y-Bar" to see the before and after affect of rotating the Y-Bar. When rotating the Y-Bar you will force the first row of bricks to form a slight angle.

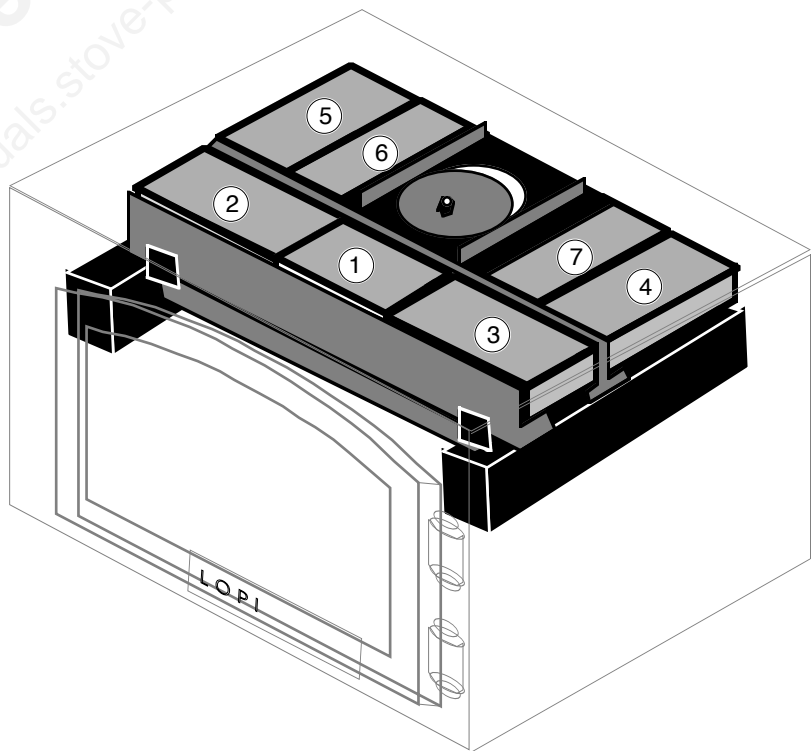

REPLACEMENT PARTS AND REMOVAL INSTRUCTIONS (Continued)

Removing and Replacing the Firebricks (Continued)

REMOVING THE BAFFLE (TOP) FIREBRICKS & COMPONENTS (Continued)

4. With the "Y" Bar rotated, pull the front three bricks over the "Y" Bar and out of the appliance (bricks #1 through #3 in the illustration on the preceding page).
5. Remove the "Y" Bar.
6. Remove the Rear Baffle Angle (referred to as the "T" Bar) by sliding it out in a forward direction. This will cause some of the back bricks to tilt slightly.
7. Pull out the two bricks that are touching the side walls of the firebox (bricks #4 and #5). These are tight, so some force may be needed to pull them out.
8. Slide the remaining bricks to the side, being careful to catch the damper plate and damper when they no longer rest on top of these two bricks (bricks #6 through #8).
9. Remove the remaining bricks along with the damper plate and damper.

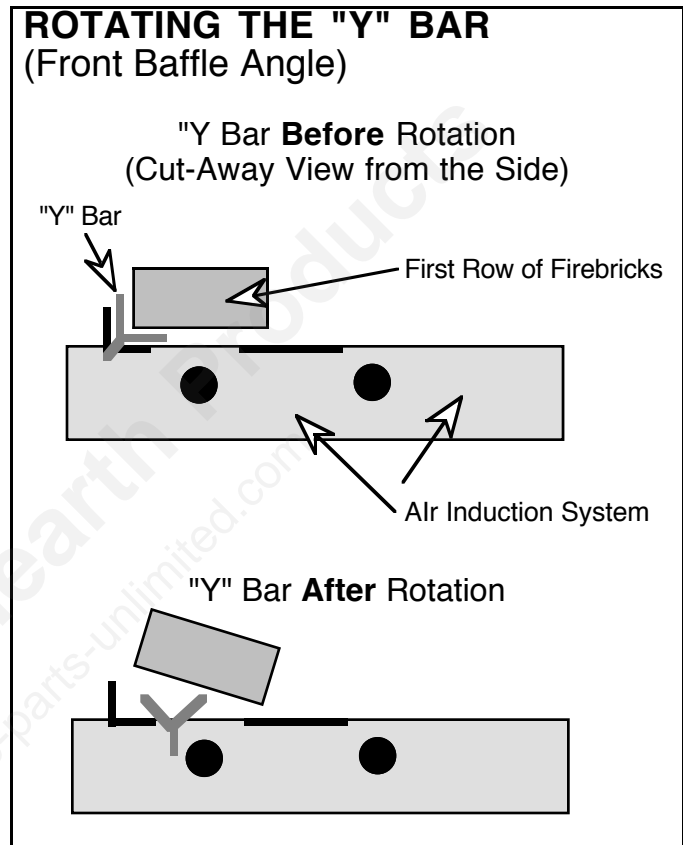

REPLACING THE BAFFLE (TOP) FIREBRICKS & COMPONENTS

1. Place two bricks in the far rear of the appliance so they rest on top of the air induction system and are approximately 9" apart.
2. Place the damper on top of the damper plate, with the slot of the damper plate close to you. Insert the damper plate with the damper resting on top of it so the two pieces rest on one of the bricks placed in the far rear. It will rest at a slight angle to the left or the right, depending on which firebrick you placed it on.
3. Line up the damper rod so the peg is directly above the slot on the damper. It must be inserted into the slot for your damper control to work.
4. Lift the damper plate onto the other firebrick, making sure the damper rod is inserted into the damper. The damper plate should be level and centered in your appliance. Test the damper control by gently pushing it back in forth, checking to see if the damper moves. If it does move correctly, proceed. If the damper does not move, remove one of the firebricks, re-align the damper, and proceed with this step again.

REPLACEMENT PARTS AND REMOVAL INSTRUCTIONS (Continued)

Removing and Replacing the Firebricks (Continued)

REPLACING THE BAFFLE (TOP) FIREBRICKS & COMPONENTS (Continued)

5. Slide two more firebricks into the rear of the appliance. They will fit very snug, so some effort may be required. The firebricks will not lie flat until the "T" Bar is placed into position.

6. Slide the "T" Bar into position, making sure it goes under the back firebricks.

7. Place the "Y" Bar into position, but rotate it so that it looks like the drawing on the previous page: "Y Bar after Rotation".

8. Slide the forward firebricks into position. The smaller firebrick should be in the middle.

9. Rotate the "Y" Bar so that it looks like the drawing on the previous page: "Y Bar before Rotation".

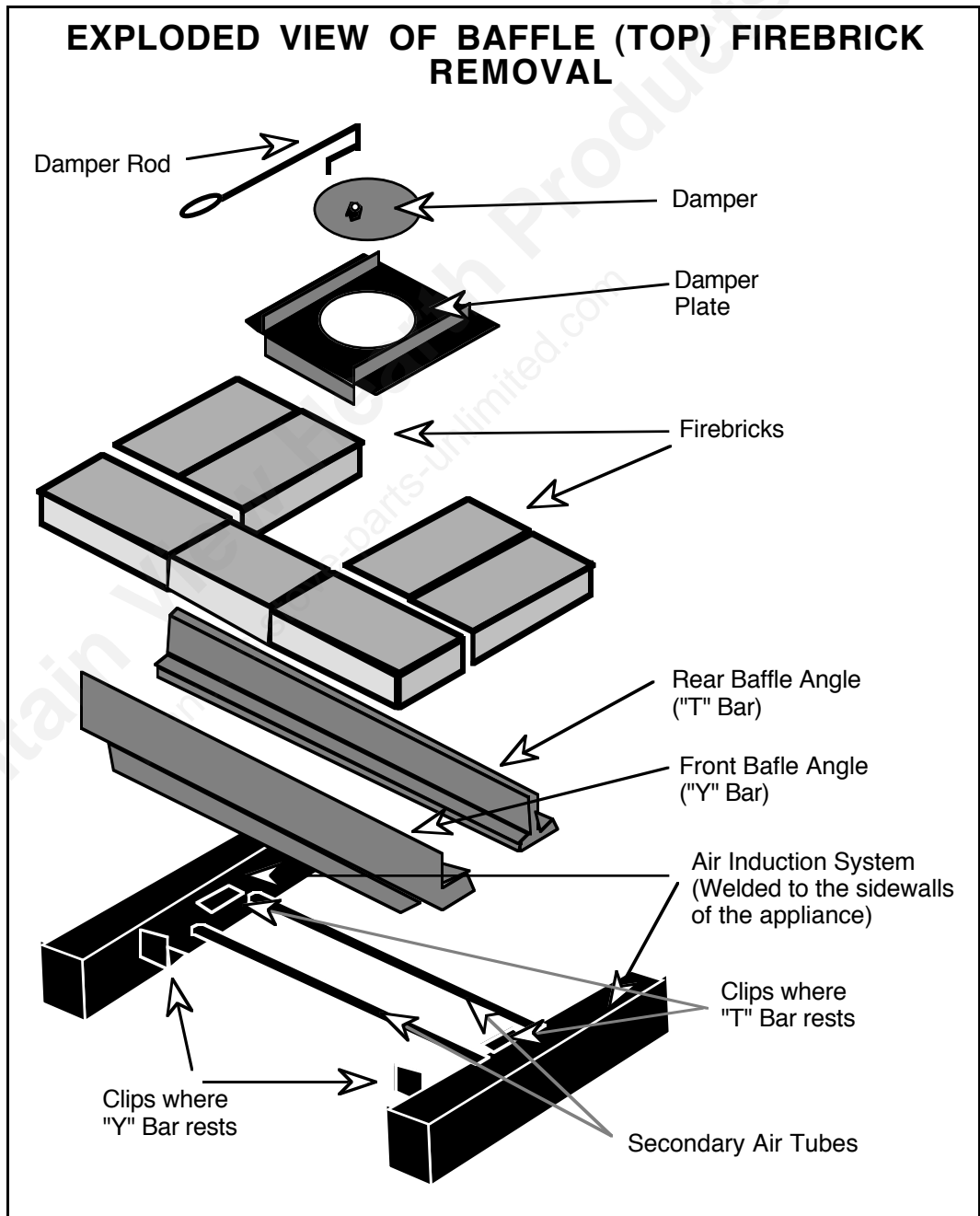

REPLACEMENT PARTS AND REMOVAL INSTRUCTIONS (Continued)

Removing and Replacing the Secondary Air Tubes

The secondary air tubes are two tubes with holes that run along the top of the firebox. Over time they may wear and become ineffective. The secondary air tubes should be replaced if they crack or show severe deterioration, because they supply air into the firebox that allows for a more efficient fire. There are two secondary air tubes, one is in the front of the firebox and the other is in back. These parts are available from your dealer.

To remove either secondary air tube, first remove the two pins located on the right side of the firebox that hold the tube in place.

These pins are removed by using a screwdriver or needle-nose pliers to pry them out of their holes. The pins are held in place by flanges on the pins that expand once they are pushed into the hole. Therefore, you may have to pry with some amount of force when trying to remove them.

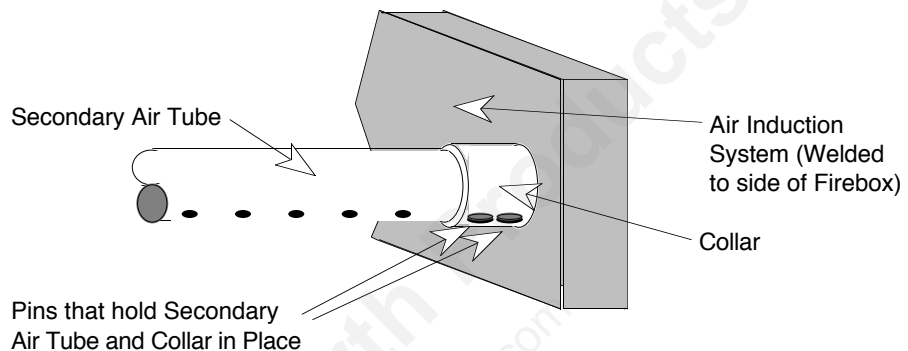

Slide collar to the left after removing both of the pins.

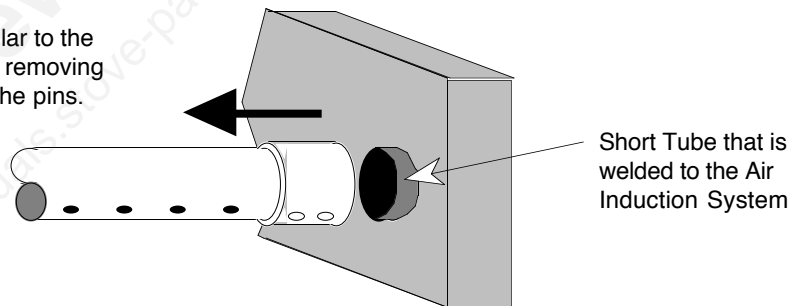

One pin holds the secondary air tube to a collar while the other pin holds the collar to a short tube welded to the air induction system. Once both pins are removed, the collar can be slid to the left and the secondary air tube and collar can be pulled down and away from the left side. To replace the secondary air tube, place the collar on the secondary air tube, insert the secondary air tube into the hole on the left side of the firebox, and slide the collar over to the right so it slides over the short tube that is welded to the air induction system on the right side. Then line up the secondary air tube and collar so the holes for the pins line up and insert both new pins that are included with the replacement air tube kit.

5-YEAR WARRANTY

TRAVIS INDUSTRIES, INC. warrants the **LOPI FLUSH BAY 96** appliance to be defect-free in material and workmanship for five (5) years from the date of purchase, with the exception of the glass, paint, refractory, removable baffle parts and blowers. The blowers and removable baffle parts are warranted for one (1) year from the date of purchase to be defect - free in material and workmanship. The glass, paint and refractory are not warranted.

Exclusions to this limited warranty include: Injury, malfunction to the product, loss, damage, defect, failure to function due to accident, negligence, misuse, improper installation, alteration or adjustment of the manufacturer's settings of components, lack of proper and regular maintenance, damage incurred while the appliance is in transit, alteration, or act of God.

This limited warranty excludes damage caused by normal wear and tear, such as paint discoloration or chipping, worn or torn gasketing, eroded or cracked refractory, etc. Also excluded is damage to the appliance caused by abuse, improper installation, the use of fuel or fuel loads other than specified by the manufacturer or use not set forth in the Owner's Manual. An over-fired condition will cause warped metal parts and discolored or burned-off paint.

TRAVIS INDUSTRIES, INC. is free of liability for any damages caused by the appliance, as well as inconvenience expenses, material and labor charges incurred by the removal or reinstallation of any **LOPI** appliance. Incidental or consequential damages are not covered by this warranty. In some states, the exclusion of incidental or consequential damage may not apply.

This warranty does not cover any loss or damage incurred by the use or removal of any component or apparatus to or from the **LOPI** appliance without the express written permission of TRAVIS INDUSTRIES, INC. and bearing a TRAVIS INDUSTRIES, INC. label of approval.

Any statement or representation of **LOPI** products and their performance contained in **LOPI** advertising, packaging literature, or printed material is not part of this limited warranty.

This warranty is automatically voided if the appliance's serial number has been removed or altered in any way.

Only the original purchaser of an **LOPI** appliance is covered by this warranty. If the appliance is used for commercial purposes, it is excluded from this warranty.

No dealer, distributor, or similar person has the authority to represent or warrant **LOPI** products beyond the terms contained within this warranty. TRAVIS INDUSTRIES, INC. assumes no liability for such warranties or representations.

THIS LIMITED WARRANTY IS THE ONLY WARRANTY SUPPLIED BY TRAVIS INDUSTRIES, INC., THE MANUFACTURER OF THE APPLIANCES. ALL OTHER WARRANTIES, WHETHER EXPRESS OR IMPLIED, ARE HEREBY EXPRESSLY DISCLAIMED AND PURCHASER'S RECOURSE IS EXPRESSLY LIMITED TO THE WARRANTIES SET FORTH HEREIN.

This warranty is limited to the time frame set forth above. In some states, time limitations on warranties do not apply.

HOW TO USE YOUR TRAVIS INDUSTRIES, INC. FIVE-YEAR WARRANTY: If you find your appliance to be defective in workmanship or material within a 5-year period from the date of purchase contact your local authorized LOPI dealer. If your dealer is unable to repair your appliance's defect, you may process a warranty claim through TRAVIS INDUSTRIES, INC., including the name of the dealership where you purchased the appliance, a copy of your receipt showing the date of the appliance's purchase, and the serial number on your appliance. At that time, you will be asked to ship your appliance, freight charges prepaid, to TRAVIS INDUSTRIES, INC. TRAVIS INDUSTRIES, INC., at its option, will repair or replace, free of charge, your LOPI appliance if it is found to be defective in material or workmanship within the time frame stated within this limited warranty. In addition, TRAVIS INDUSTRIES, INC. will refurbish your appliance at no charge to you, restoring its appearance and condition. TRAVIS INDUSTRIES, INC. will ship your appliance, freight charges prepaid by TRAVIS INDUSTRIES, INC., to your regional distributor, or dealership.

To register your TRAVIS INDUSTRIES, INC. Five-Year Warranty, complete the enclosed warranty card and mail it within ten (10) days of the appliance purchase date to: TRAVIS INDUSTRIES, INC., 10850 117th Place N.E., Kirkland, WA 98033.

OTHER RIGHTS:

This warranty provides you with certain legal rights. You may have additional rights, which vary from state to state, in regards to this warranty.

APPLIANCE SERIAL NUMBER _____

DATE OF PURCHASE _____

DEALER NAME AND ADDRESS _____

**Complete
and save
for your
records**

Travis Industries, Inc. reserves the right to change, without notice, product features or specifications described.

SAFETY LABEL