

# Freedom Bay

Owner's Manual

- May, 2001 -

- Masonry Fireplace Insert

## SAFETY NOTICE:

If this appliance is not properly installed, a house fire may result. For your safety, follow the installation directions. Contact local building or fire officials about restrictions and installation inspection requirements in your area.

# Freedom Bay Fireplace Insert

 **Travis Industries, Inc.**  
10850 117th Place N.E. Kirkland, WA 98033

Part # 93508026

\$10.00

Warnock Hersey



Listed

## Introduction

We welcome you as a new owner of a Lopi Freedom Bay wood-burning appliance. In purchasing a Lopi Freedom Bay you have joined the growing ranks of concerned individuals whose selection of an energy system reflects both a concern for the environment and aesthetics. The Lopi Freedom Bay is one of the finest appliances the world over. This manual will explain the installation, operation, and maintenance of this appliance. Please familiarize yourself with the Owner's Manual before operating your appliance and save the manual for future reference. Included are helpful hints and suggestions which will make the installation and operation of your new appliance an easier and more enjoyable experience. We offer our continual support and guidance to help you achieve the maximum benefit and enjoyment from your appliance.

## Important Information

No other Lopi Freedom Bay appliance has the same serial number as yours. The serial number is stamped onto the label on the right side of the appliance.

This serial number will be needed in case you require service of any type.

Model: LOPI Freedom Bay

Serial Number: \_\_\_\_\_

Purchase Date: \_\_\_\_\_

Purchased From: \_\_\_\_\_

\_\_\_\_\_  
\_\_\_\_\_

### **Mail your Warranty Card Today, and Save Your Bill of Sale.**

To receive full warranty coverage, you will need to show evidence of the date you purchased your appliance. Do not mail your Bill of Sale to us.

We suggest that you attach your Bill of Sale to this page so that you will have all the information you need in one place should the need for service or information occur.

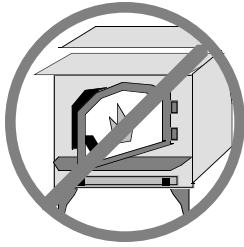

- The viewing door must be closed and latched during operation.
- Never block free airflow through the air vents on this appliance.



- Gasoline or other flammable liquids must never be used to start the fire or "Freshen Up" the fire. Do not store or use gasoline or other flammable liquids in the vicinity of this appliance.

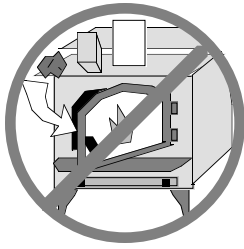

- This appliance is designed and approved for the burning of cord wood only. Do not attempt to burn any other type of fuel other than cord wood in this appliance, it will void all warranties and safety listings.

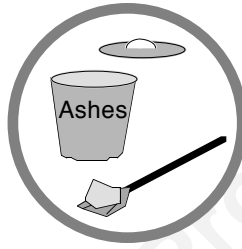

- Ashes must be disposed in a metal container with a tight lid and placed on a non-combustible surface well away from the home or structure.



- Do not touch the appliance while it is hot and educate all children of the danger of a high-temperature appliance. Young children should be supervised when they are in the same room as the appliance.

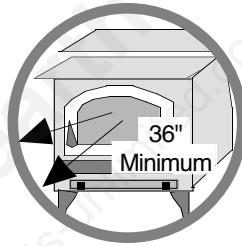

- Keep furniture, drapes, curtains, wood, paper, and other combustibles a minimum of 36" away from the appliance.

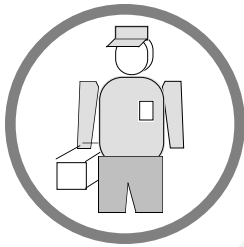

- This appliance must be properly installed to prevent the possibility of a house fire. The instructions must be strictly adhered to. Do not use makeshift methods or compromise in the installation.



- Contact your local building officials to obtain a permit and information on any installation restrictions or inspection requirements in your area. Notify your insurance company of this appliance as well.

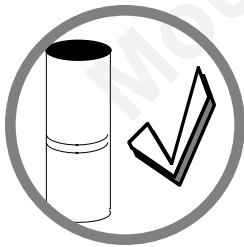

- Inspect the chimney connector and chimney at least twice monthly and clean if necessary. Creosote may build up and cause a house fire.
- Do not connect this appliance to any chimney serving another appliance.

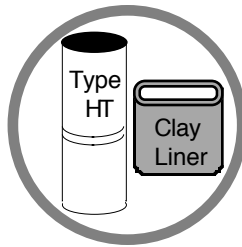

- This appliance must be connected to a listed high temperature (HT) residential type chimney or an approved masonry chimney with a standard clay tile, or stainless steel liner.

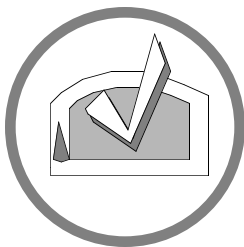

- Maintain the door and glass seal and keep them in good condition.
- Avoid placing wood against the glass when loading. Do not slam the door or strike the glass.

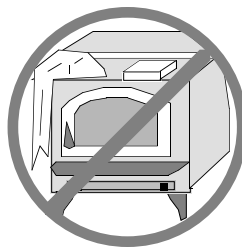

- Do not place clothing or other flammable items on or near this appliance.



- Never try to repair or replace any part of this appliance unless instructions are given in this manual. All other work must be done by a trained technician.

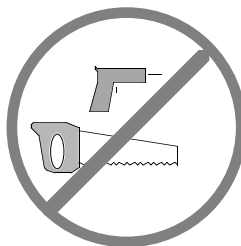

- Do not make any changes or modifications to an existing masonry fireplace or chimney to install this appliance.
- Do not make any changes to the appliance to increase combustion air.

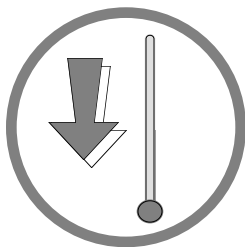

- Allow the appliance to cool before carrying out any maintenance or cleaning.



- Overfiring the appliance may cause a house fire. If a unit or chimney connector glows, you are overfiring.

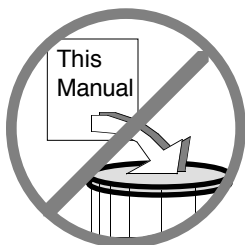

- Do not throw this manual away. This manual has important operating and maintenance instructions that you will need at a later time. Always follow the instructions in this manual.



- Do not use a grate or other device to elevate the fire off of the firebox floor. Burn the fire directly on the bricks.



- **Travis Industries, Inc. grants no warranty, implied or stated, for the installation or maintenance of your appliance, and assumes no responsibility of any consequential damage(s).**

**Introduction and Important Information**

Introduction and Important Information ..... 1  
 Safety Precautions..... 2

**Features and Specifications**

Features and Specifications .....5

**Insert Installation**

Before You Begin..... 6  
 Planning The Installation..... 6  
 Preparation for Installation..... 6  
 Insert Installation Considerations..... 6  
 Optional Equipment Requirements ..... 6  
 Insert Placement Requirements .....7  
 Hearth Requirements..... 7  
 Insert Size Requirements .....7  
 Masonry Fireplace Requirements ..... 8  
 Leveling Bolt Installation .....8  
 Blower Installation.....8  
 Block-Off Plate Installation..... 9

**INSTALLATION DIAGRAMS**

Insert with Positive Connection .....10  
 Insert with Direct Connection .....10  
 Insert with Face Seal Connection ..... 11

**Operating Your Appliance**

Before You Begin..... 12  
 Paint Curing ..... 12  
 Location of Controls.....12  
     Approximate Air Control Settings ..... 12  
     Bypass Control.....13  
 Learning to Burn your Appliance..... 13  
     How to Start a Hot Fire Quickly ..... 13  
     How to Reload Your Appliance ..... 14  
     How to Adjust the Heat Output Precisely ..... 14  
     How to Obtain an Overnight Burn ..... 15  
     Good Burning Habits ..... 15  
 Blower Operation ..... 16  
 A Word about Wood .....17

**Maintaining Your Appliance**

Maintenance Schedule..... 19  
 Remove Ash From The Firebox (If Necessary)..... 19  
 Clean The Viewing Glass (If Necessary) ..... 19  
 Clean The Brass (If Necessary) ..... 19  
 Check For Creosote Buildup..... 19  
 Door And Glass Inspection ..... 20  
     Adjusting the Door Cam ..... 20  
     Replacing the Door Gasket ..... 21  
     Replacing the Glass or Glass Gasket..... 21  
 Lubricate The Door Hinge..... 21  
 Touch-Up Paint ..... 22  
 Blower Cleaning ..... 22  
 Firebrick And Baffle Inspection And Cleaning..... 22  
     Firebrick Removal and Replacement Inst. .... 23  
     Baffle Removal and Replacement Instructions..... 23  
     Secondary Air Tube Replacement Instructions .... 25  
 Replacement Parts List..... 25

**Troubleshooting**

Troubleshooting Table ..... 26

**Warranty**

Warranty..... 27

**Listing Information**

Listing Information..... 28

**Optional Equipment**

Surround Panel Installation ..... 29  
 Insulation Installation..... 30  
 Brass Trim Installation (Optional) ..... 30  
 Flue Adapter Installation ..... 31

**Index**

Index ..... 32

**Installation Options:**

- Insert into a Masonry Fireplace

**Features:**

- |  |   |
|--|---|
| <ul style="list-style-type: none"> <li>• EPA Phase II Approved</li> <li>• 3.1 Cubic Foot Firebox Volume</li> <li>• Single, Push/Pull Operating Control</li> <li>• Accepts Logs Up to 24" Long</li> </ul> | <ul style="list-style-type: none"> <li>• Long Burn Time - Up to 12 Hours</li> <li>• 5/16 to 3/16" Steel Construction</li> <li>• Heavy Duty Refractory Firebrick</li> <li>• Optional High-Tech Blower</li> </ul> |
|--|---|

**Heating Specifications:**

Approximate Maximum Heating Capacity (in square feet)*	1,200 to 2,250
Maximum BTU's per Hour (Cord Wood Calculation)	74,300
Overall Efficiency (Oregon Method)	70%
Maximum Burn Time (Hours)	12

\* Heating capacity will vary depending on the home's floor plan, degree of insulation, and the outside temperature. It is also affected by the quality and moisture level of the fuel.

**Dimensions:**

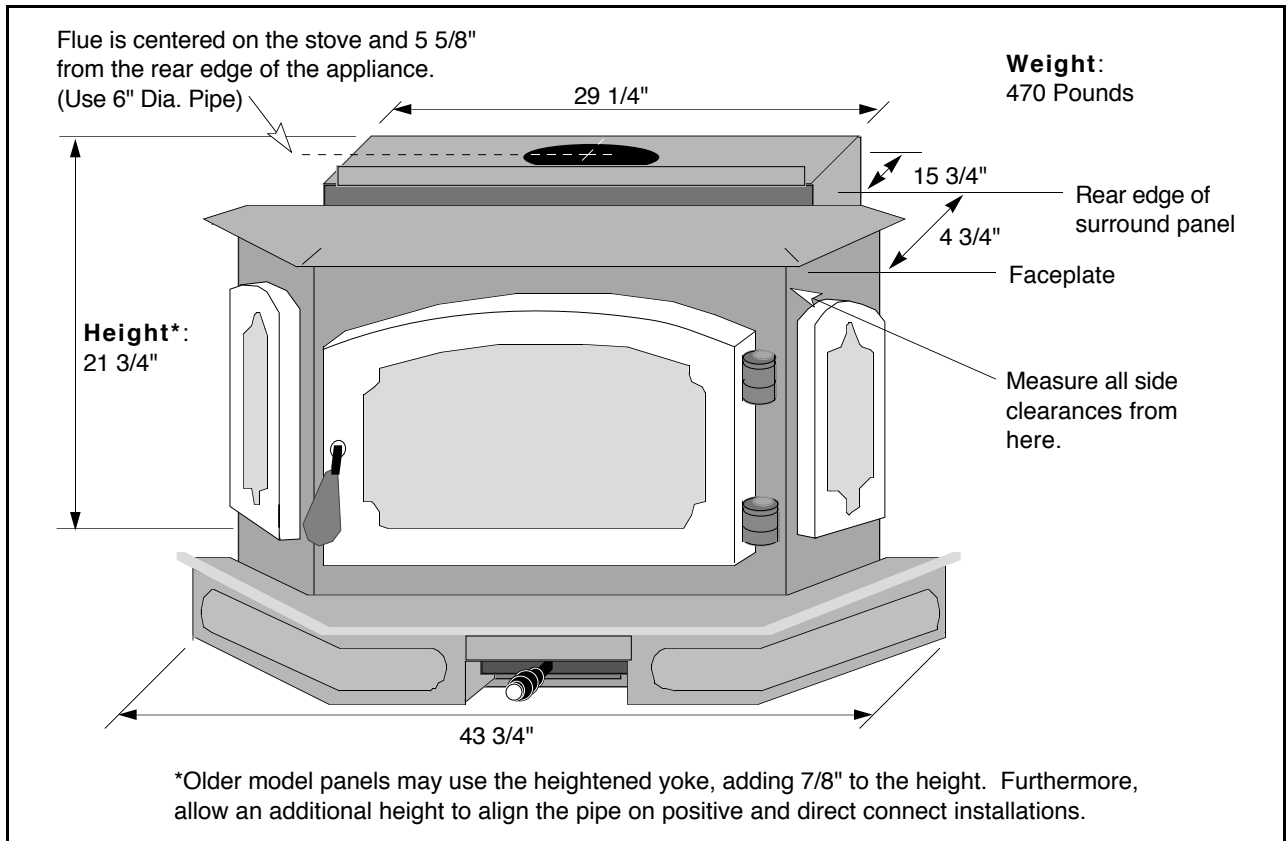

**Emissions:** 2.6 Grams Per Hour (EPA Phase II Approved) – Tests conducted by E.E.S.P.C. Lab.

**SAFETY NOTICE:**

**If this appliance is not properly installed, a house fire may result. For your safety, follow the installation directions. Contact local building or fire officials about restrictions and installation inspection requirements in your area.**

- Check with local building officials for any permits required for installation of this stove and notify your insurance company before proceeding with installation.

**PLANNING THE INSTALLATION**

**HINT:** We suggest that you have an authorized Travis Industries dealer install your insert. If you install the insert yourself, your authorized dealer should review your plans for installation.

This insert is approved for installation into an existing masonry fireplace. Depending upon your installation concerns, several options are yours to provide the most desirable installation. The sections that follow detail the requirements that must be met for a safe installation. To further help installation, the most common types of installations are explained in the section "Insert Installation Considerations". Prior to installing your insert make a detailed plan with dimensions to double-check them against all of the requirements listed.

**PREPARATION FOR INSTALLATION**

- Check for damage to the exterior of the insert (dents should be reported, scratches can be fixed by applying touch up paint).
- Check the interior of the firebox (cracked firebrick should be replaced, displaced baffle components should be replaced).
- Remove the box that contains the blower. Place it aside and install it last (see "Blower Installation" on page 8)

**HINT:** The insert can be lightened by removing the firebricks and baffle. - see "Firebrick and Baffle Inspection and Cleaning" on pages 22 - 24.

**INSERT INSTALLATION CONSIDERATIONS**

The table below details the most common types of installations and the considerations for each type of insert installation. Alternative methods of installation are available if they comply with local building codes.

<b>Installation Type</b>	<b>Considerations</b>
Insert with Positive Flue (Full Reline) (Page 10)	<ul style="list-style-type: none"> <li>• Utilizes existing masonry fireplace</li> <li>• Provides best draft</li> <li>• Easiest to clean</li> </ul>
Insert with Direct Connect Flue (Page 10)	<ul style="list-style-type: none"> <li>• Utilizes existing masonry fireplace</li> <li>• Provides good draft</li> <li>• Requires fireplace block-off plate - see page 9</li> </ul>
Insert with Face Seal Connection (Page 11)	<ul style="list-style-type: none"> <li>• Utilizes masonry fireplaces with a cross section of 28" to 144"</li> <li>• Provides okay draft</li> <li>• Easiest to install</li> <li>• Requires insulation (see "Insulation Installation" on page 30)</li> </ul>

**OPTIONAL EQUIPMENT REQUIREMENTS** (See the back of this manual for installation instructions)

- Must be installed with the surround panels

## INSERT PLACEMENT REQUIREMENTS (See the illustration below)

- The insert must be placed so that no combustibles are within, or can swing within (e.g. drapes, doors), 36" of the front of the insert
- Insert and hearth must be installed on a level, secure floor
- Sidewalls must maintain a minimum 15" to the insert
- Non-combustible side facing must extend 13 1/2" from the insert
- Non-combustible top facing must extend 30" above the insert (17" with mantle shield)
- Mantle must be a minimum 32" above the insert (19" with mantle shield)
- Hearth must extend 16" in front of the faceplate
- Hearth must extend 8" from the sides of the insert

The diagram illustrates the placement of a fireplace insert within a masonry fireplace. It shows a brick surround with a 'Combustible Mantle' on top and 'Non-Combustible Facing' on the sides. The insert is positioned within 'Surround Panels'. Measurements A through F indicate the required clearances: A (side wall to insert), B (side facing), C (top facing), D (mantle to insert), E (hearth front), and F (hearth side). A note indicates that side clearances should be measured from the side wall.

Minimum Clearances	Masonry Fireplace
A Sidewall to Insert	15"
B Side Facing	13 1/2"
C Top Facing	30"
With mantle shield	17"
D Mantle to Insert	32"
With mantle shield	19"
E Hearth (Front)*	16"
F Hearth (Side)**	8"

\* Measure from faceplate, does not include the distance the insert sticks out on the hearth (4 3/4").

\*\*Total hearth width must be at least 45 1/4"

## HEARTH REQUIREMENTS (See the illustration above)

- Must extend 16" in front of the insert and 8" on both sides (total of 20 3/4" deep by 45 1/4" wide)
- Must be non-combustible and at least .018" thick (26 gage)

## INSERT SIZE REQUIREMENTS

The diagram shows the dimensions of the fireplace opening for the insert. Measurements A through F indicate the required fireplace size: A (front height), B (rear height), C (front width), D (rear width), E (depth), and F (hearth). A note indicates that older model panels may use a heightened yoke, adding 7/8" to the height. An additional note states that a room is needed to align the pipe on positive and direct connect installations.

Minimum Fireplace Size	Masonry Fireplace
A Height* (front)	21 3/4"
B Height* (rear)	21 3/4"
C Width (front)	29 1/4"
D Width (rear)	29 1/4"
E Depth	15 3/4"
F Hearth**	4 3/4"

\* Older model panels may use the heightened yoke, adding 7/8" to the height. Furthermore, additional room is needed to align the pipe on positive and direct connect installations.

\*\* Does not include the required 16" of floor protection in front.

**MASONRY FIREPLACE REQUIREMENTS**

- Chimney must have a clay tile liner or a stainless steel liner (positive connection)
- Entire fireplace, including chimney, must be clean and undamaged. Any damage must be repaired prior to installation of the insert
- Chimney height: 15' minimum; 33' maximum.
- Entire fireplace, including chimney, must meet local building requirements

**Drafting** This appliance relies upon natural draft to operate. External forces, such as wind, barometric pressure, topography, or factors of the home (negative pressure from exhaust fans, chimneys, air infiltration, etc.), may adversely affect draft. Travis Industries can not be responsible for external forces leading to less than optimal performance.

**LEVELING BOLT INSTALLATION**

Inside the accessory pack are a pair of leveling bolts used to level the insert if the fireplace has a stepped-up hearth. To install, raise the rear of the insert up and insert the leveling bolts into the holes in the rear corners of the insert. Screw the bolts down until they extend the same height as the hearth steps up. After the insert is installed, fine-tune the leveling bolts to level the insert (see the illustration below).

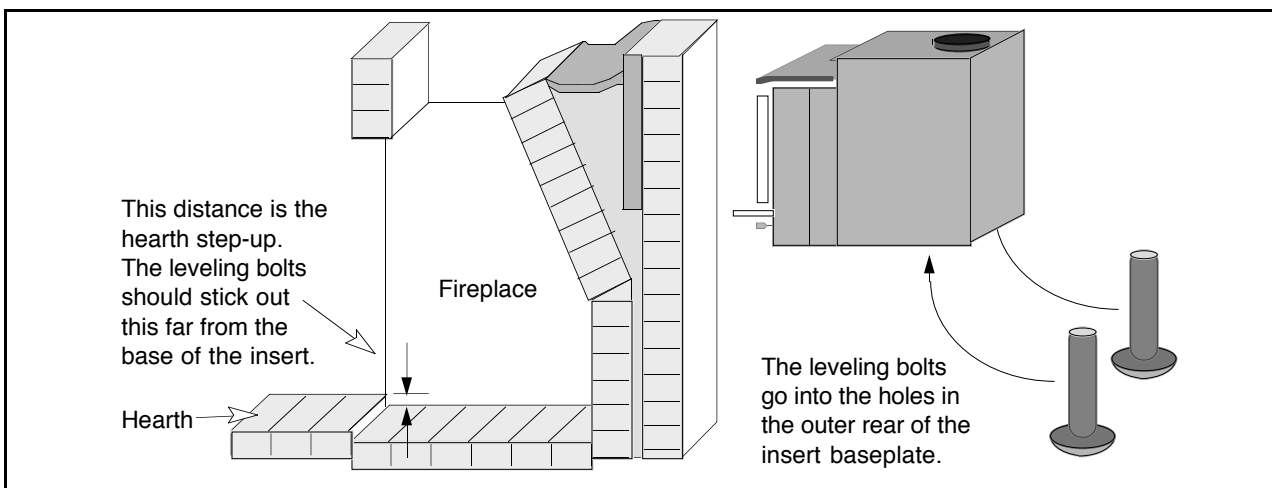

**BLOWER INSTALLATION**

The included blower is fragile and should be installed last (see directions below).

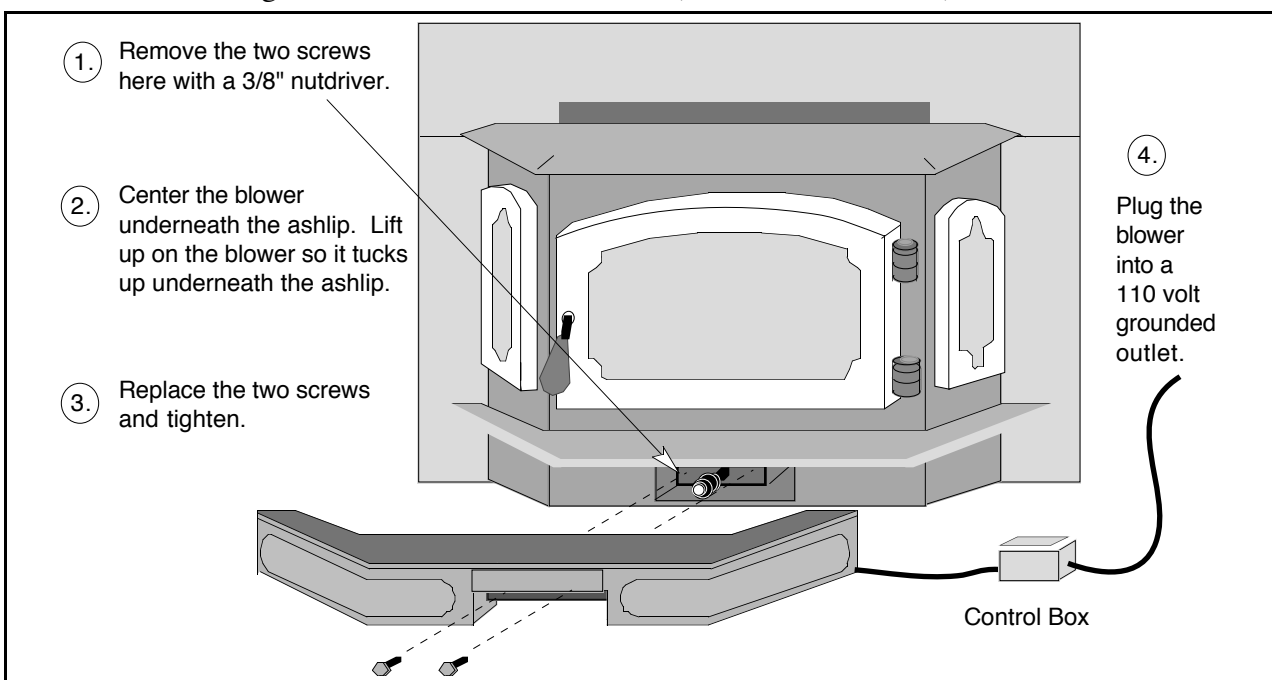

**BLOCK-OFF PLATE INSTALLATION**

Whenever this appliance is installed with a direct connection a block-off plate, or other non-combustible seal-off device (e.g. damper adapter), will need to be installed. This device is used to seal the chimney, insuring no smoke enters the home and providing the chimney system with a seal to provide greater draft. The directions below detail the steps for construction and installation of a block-off plate.

1. Determine a location for the block-off plate at the top of the firebox below the damper area (make it high enough to allow installation of the connection pipe). The location should be level and in an area where it can be mounted easily. Measure the width at the rear ("A") and front ("B") of the firebox at the height where the block-off plate will be installed (see the illustration below). Then measure the depth of the location where the block-off plate will be installed ("C").
2. Make a cardboard template of the measurements, but add a 2" flange to each side. This flange will be used to mount the block-off plate to the inside of the firebox. Bend the flanges downwards on the template and place it inside the fireplace. If the template fits correctly in its planned location, go to the next step. If it does not, make a new template with the appropriate corrections until it fits correctly.
3. With the template in place, mark the location that is centered in the fireplace and 10 1/4" back from the fireplace opening. This location approximates the center of the flue when the insert is in place (a slight offset may occur based upon insert and block-off plate placement). Remove the template and cut a 6 1/4" diameter hole centered on this mark.
4. Make the block-off plate of 24 gage or thicker steel to match the template. Drill two holes in each flange for mounting the plate.
5. Mount the block-off plate using the appropriate screws. Masonry screws must be used for mounting a block-off plate in a masonry fireplace.
6. Insulate the block-off plate using high-temperature fiberglass insulation (Kaowool® or equivalent) and furnace cement (allow the cement to dry for at least 24 hours before burning).
7. After placing the appliance and installing the pipe through the block-off plate, use high-temperature fiberglass insulation and furnace cement to seal any cracks between the pipe and block-off plate.

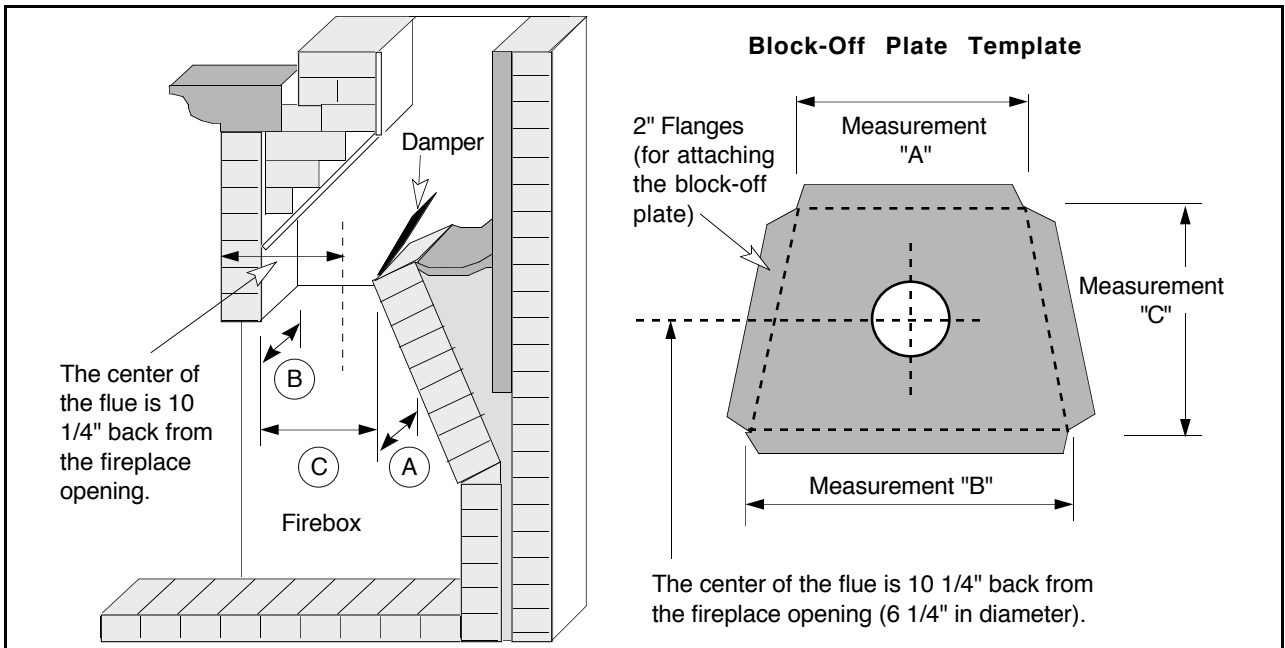

**INSERT WITH POSITIVE CONNECTION**

**NOTE:**  
Most factory-built chimney manufacturers make stainless steel chimney liners, either flexible or rigid. This provides a wide variety of installation options. Make sure to follow the manufacturer's instructions for installation and support.

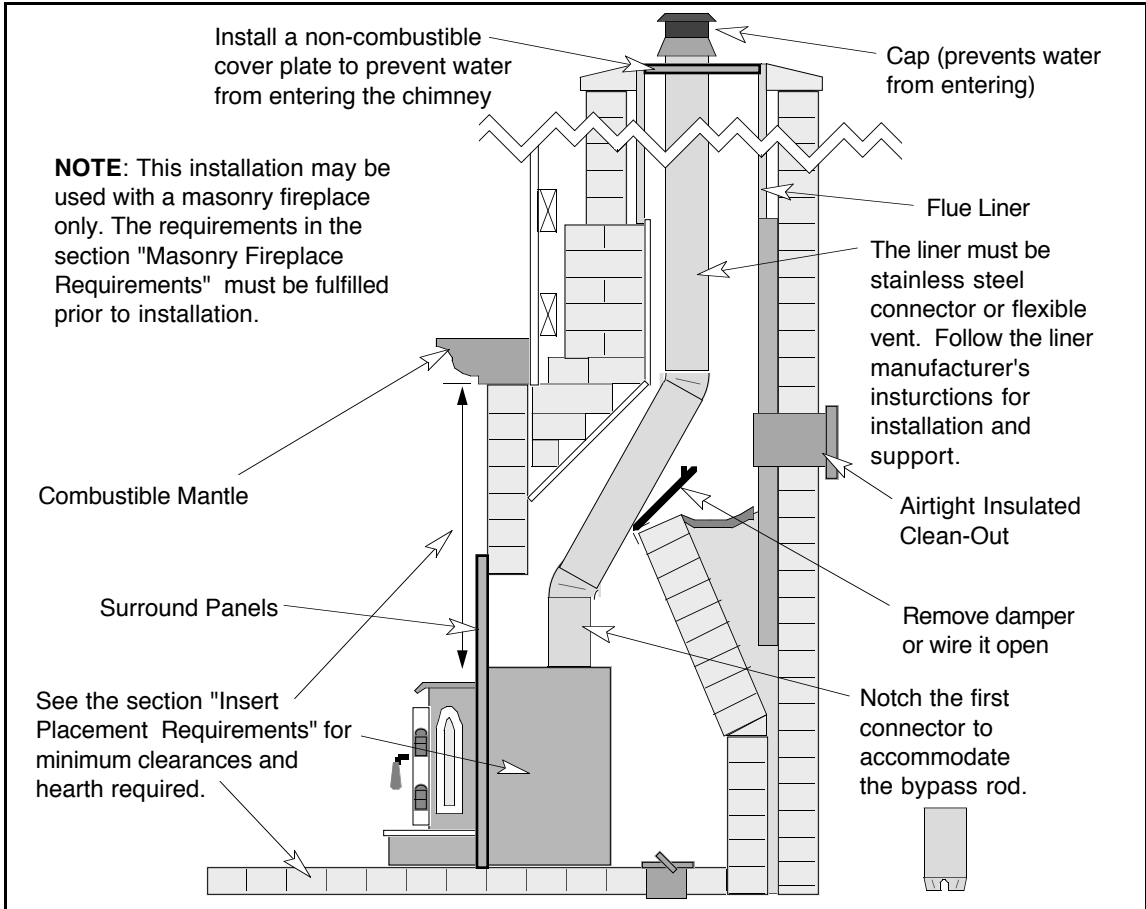

**INSERT WITH DIRECT CONNECTION (MASONRY FIREPLACE)**

**NOTE:**  
Direct connections require installation of an airtight block-off plate or damper adapter (see the section "Block-off Plate Construction" for details on constructing and installing a block-off plate).

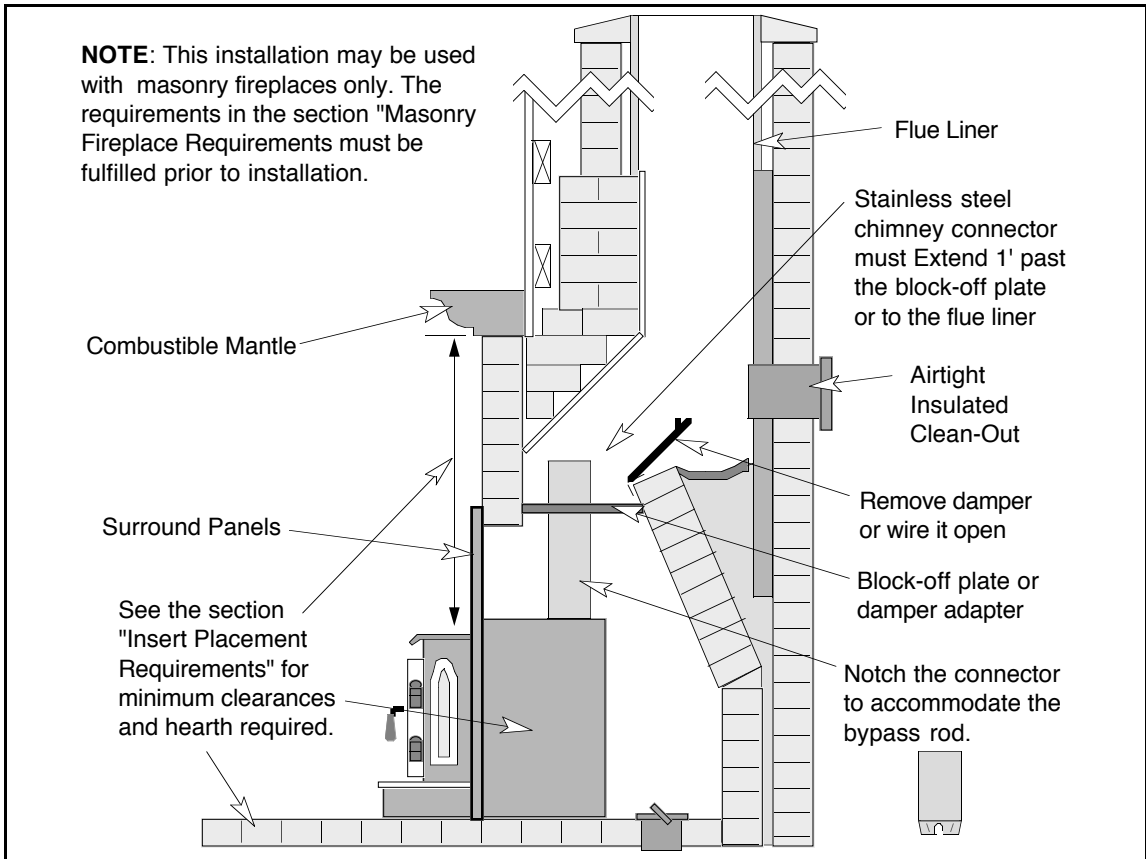

**INSERT WITH  
FACE SEAL  
CONNECTION**

**NOTE:**  
Face seal connections require installation of the surround panels and insulation (see the section "Surround Panels Installation" on page 29).

**NOTE:** This installation may be used with a masonry fireplace only. The requirements in the section "Masonry Fireplace Requirements" must be fulfilled prior to installation.

**NOTE:** It is recommended your chimney have a minimum 28 and a maximum of 144 square inch cross-sectional area to use a face seal connection, otherwise your chimney may not have sufficient draw for the fireplace insert to operate correctly.

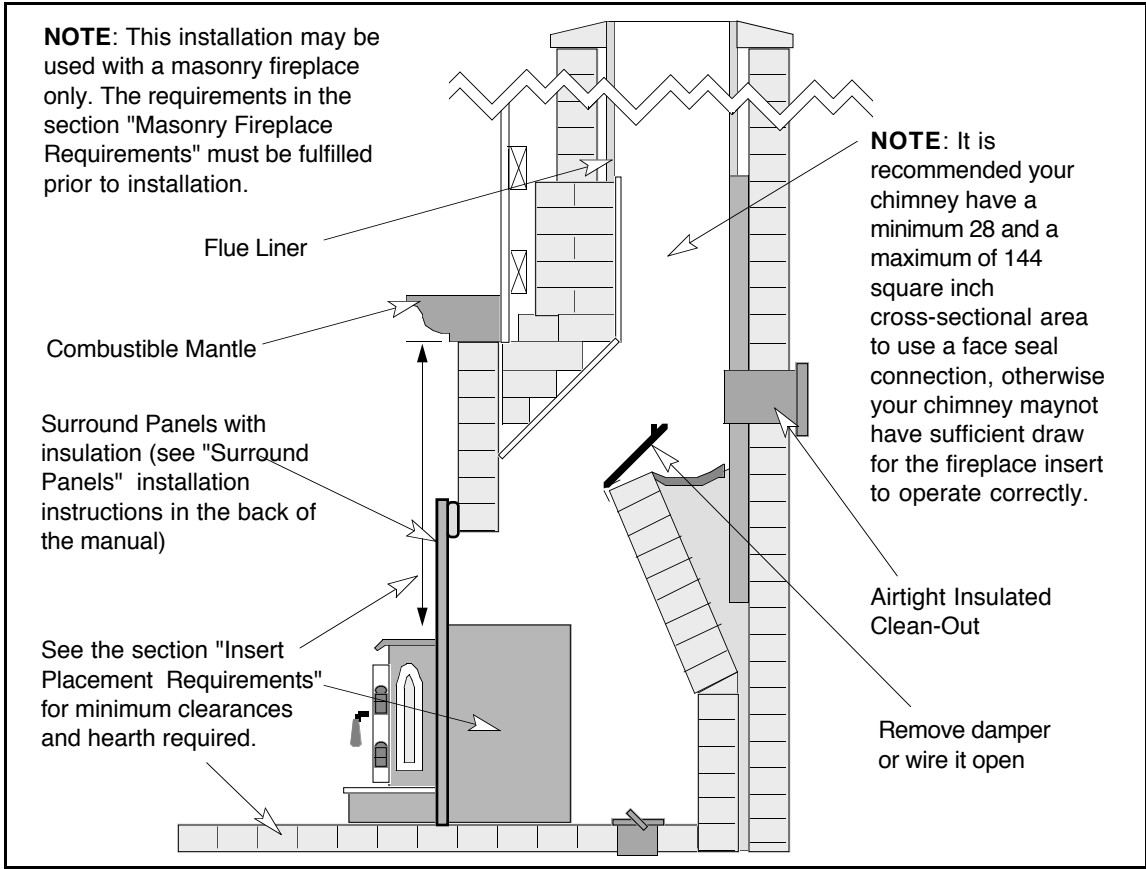

**SAFETY NOTICE:**

**If this appliance is improperly operated , a house fire may result. For your safety, read the directions below and the Safety Precautions listed on pages 2 and 3 prior to operating this appliance.**

- If you have any questions regarding the operation of this appliance, contact your dealer.
- ! Building a fire in disregard of the information provided in this section can cause permanent damage to your appliance and void your warranty.
- ! Never use gasoline, lantern fuel, kerosene, charcoal lighter fluid, or similar liquids to start of "freshen up" a fire in this appliance. Keep these liquids well away from the appliance.
- ! Keep furnishings and other combustible materials away from the appliance.

**PAINT CURING**

The paint on this stove cures under heat. Start a small fire and burn at a low rate for the first fire. You will notice fumes and smoke from the paint curing and oil burning off the steel. This is normal. We recommend you open windows to vent the room.

**ASH REMOVAL**

Ashes should be placed in a metal container with a tight fitting lid. The closed container of ashes should be placed on a noncombustible floor or on the ground, away from all combustible materials, pending final disposal. Ashes should be retained in the closed container until all cinders have thoroughly cooled.

**LOCATION OF CONTROLS**

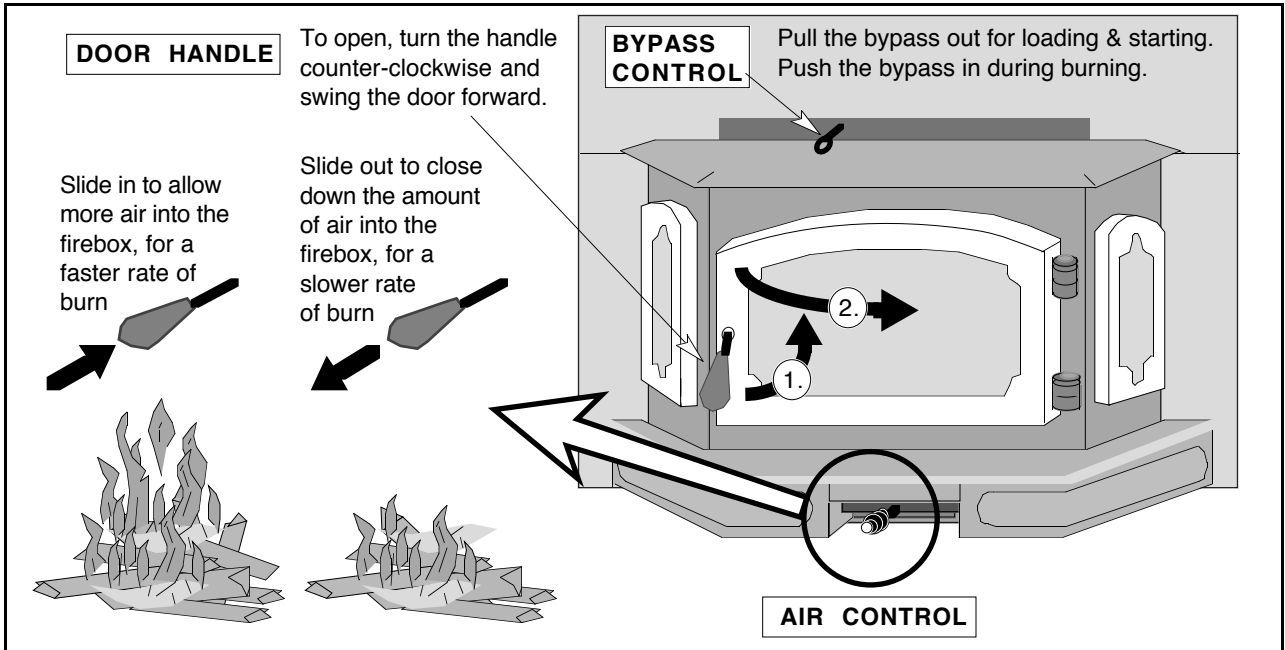

- Do not open the door when the air control is closed. This may result in a sudden flash of flames as the fire ignites with oxygen. However, this appliance has been designed to reduce this possibility.
- The controls become hot during operation – use a glove or other device if necessary.
- Open the door for refueling only, do not operate with the door open or removed.

<b>Approximate Air Control Settings:</b>	Overnight Burn .....	Fully out to 9/32" open
	Medium Burn .....	9/32" open to 5/16" open
	Medium High Burn .....	5/16" open to 7/16" open
	High Burn .....	7/16" open to pushed fully in

**Bypass Control**

The bypass control is centered along the top of the appliance and is operated by pushing or pulling the control in or out. When the control is completely pulled out, the bypass allows the smoke to go directly up the flue, creating more draft for starting the appliance or reloading. When it is pushed in, the smoke must go around the baffle which utilizes secondary combustion and makes the appliance more efficient (see the illustration below).

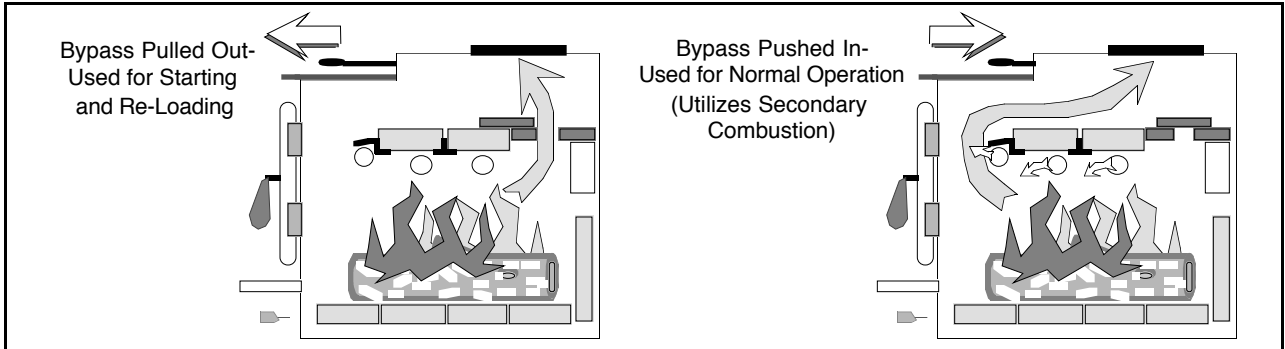

**LEARNING TO BURN YOUR APPLIANCE**

Using a wood-burning appliance takes some getting used to. Once you become accustomed to operating your appliance, you will be able to start a hot fire quickly, adjust the heat output precisely, and obtain overnight burns easier. Experienced wood burners may not need the information below, but may be able to re-affirm their skills by reading the following. The better you understand your appliance, the more rewarding you will find it.

**How to Start a Hot Fire Quickly**

Your wood-burning appliance acts much like an engine - before it will work at its best, it needs to reach a high temperature. The most common mistake in starting a fire is to use too little kindling, closing the bypass too soon, or turning the air control down too early. For good results, **YOU MUST OBTAIN AN INTENSE FIRE BEFORE CLOSING THE AIR CONTROL DOWN.** The steps below detail one method for starting a fire.

1. Pile several pieces of kindling on top of newspaper or a fire starter in the center of the firebox (it is better to have too much kindling than not enough). Place two medium sized pieces of wood on either side of kindling laying front to back.
2. Make sure the air control is fully open (push all the way in) and the bypass opened (pull all the way out). Start the newspaper or fire starter. Note: you may want to crack the door during starting to allow for more air.
3. Allow the kindling to start and burn. Then place another medium size piece of wood on top of the burning kindling so that it straddles the two medium pieces and close the door. This arrangement takes advantage of the air inlet located in the center under the door to feed the fire with adequate oxygen. You may notice the flames burning from the front to the back.
4. Let the fire burn at least 15 minutes before closing the bypass. Wait at least 30 minutes or until the appliance is fully hot before closing the air control down.

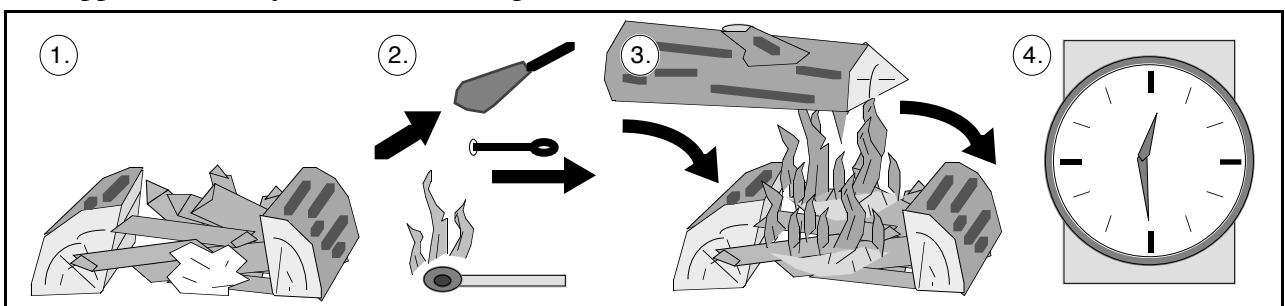

**How to Reload Your Appliance**

When reloading your appliance, you can avoid smoke entering the room by following the steps below:

1. Push the air control all the way in so the fire starts to burn quickly, helping draft.
2. Pull the bypass out all the way and wait 30 seconds to establish a strong draft.
3. Open the door one inch and let air enter the appliance for a few seconds.
4. Carefully place the new wood on top of the existing fire. Close the door and shut the bypass by pushing it all the way in. Let the fire burn on high for at least 20 minutes before turning it down – this will reduce creosote build-up.

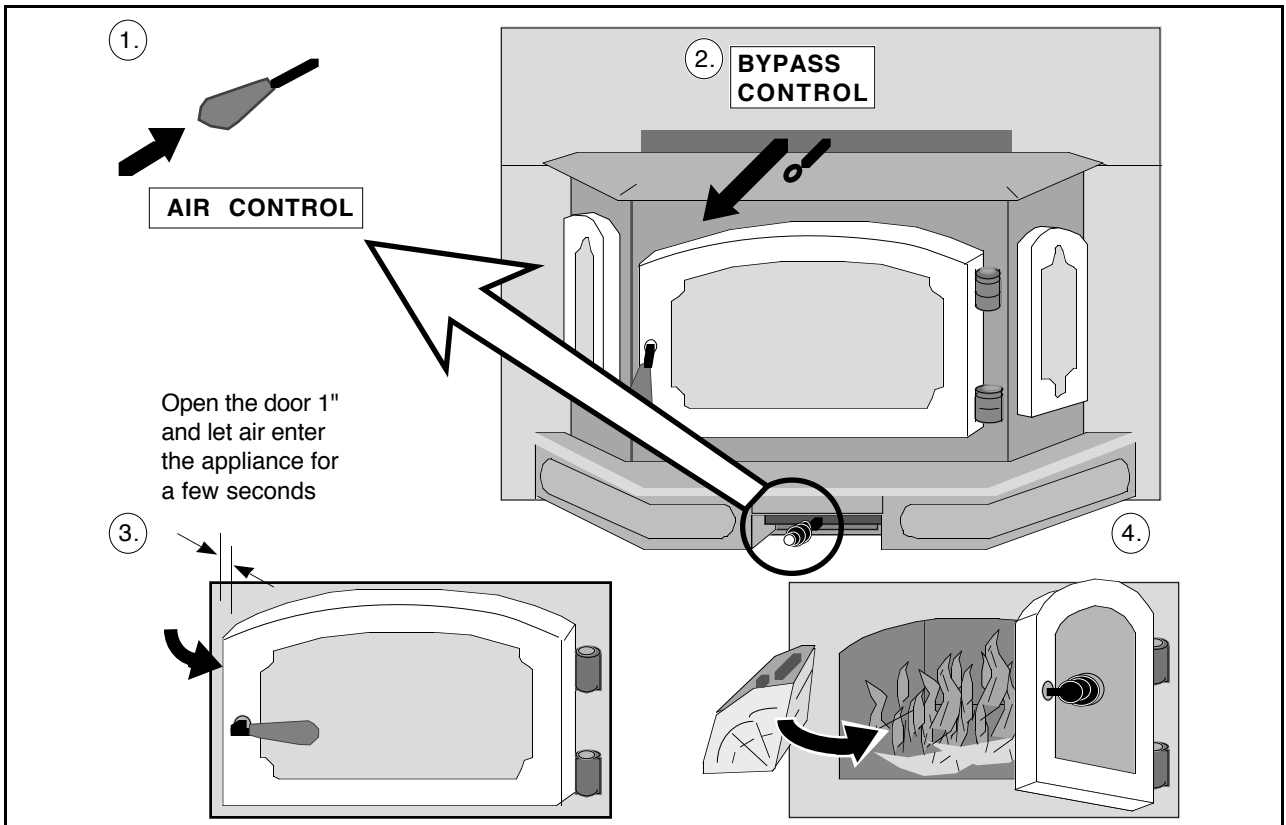

**How to Adjust the Heat Output Precisely**

One complaint from wood-burning appliance owners is controlling the heat output to obtain a consistent room temperature. The reason for this is the inherent lag time between adjusting the air control and the change in heat output. Simply put, if you turn a hot appliance down now, it will continue to put off high amounts of heat for an additional 15 minutes. To obtain consistent room temperature, think ahead.

When the room is starting to warm, and is almost up to the right temperature, turn the appliance down. If you utilize an optional blower, turn it on and off to increase or decrease room temperature. If you find the appliance must be turned down often, burn smaller, more intense fires instead. Although this means more reloadings, it will reduce creosote build-up and give a more consistent heat output.

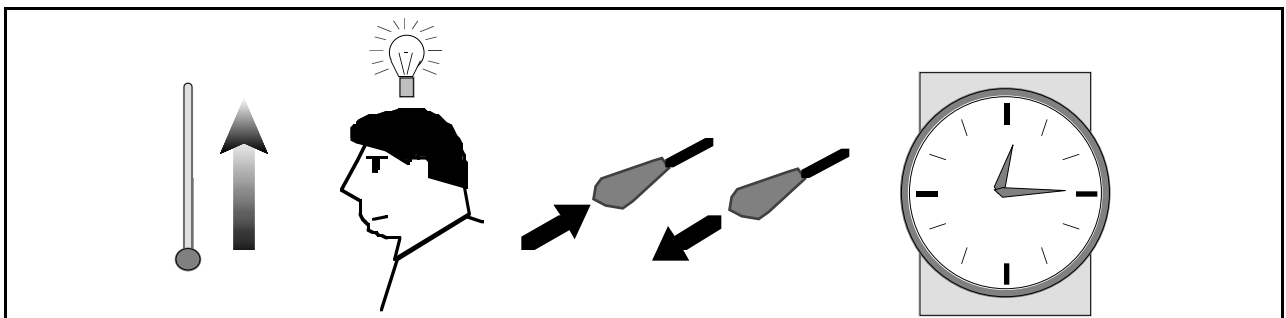

**How to Obtain an Overnight Burn**

An overnight burn of 10 hours may be obtained with a small amount of coals left over in the morning if the right steps are taken.

1. Establish a hot fire.
2. Fill the appliance with large pieces of wood, preferably hardwoods like oak or maple.
3. Let the wood burn on high for 20 to 30 minutes to allow the new pieces of wood to catch fire and burn off any moisture.
4. Pull the air control out to a low setting. **HINT:** You want an air control position that is the farthest in, yet still allows coals to be left in the morning. Experiment using air control positions that are farther and farther in until a suitable position is found.
5. In the morning, break down the coals and lay kindling and small pieces of wood on top of the coals to re-establish the fire. **NOTE:** Even the smallest amount of coals can start a new fire easily because of all the heat energy stored in the firebrick. If there are no coals left, yet the appliance is hot, you will find starting a new fire will be much easier and the appliance will start giving off heat much quicker than if started cold.

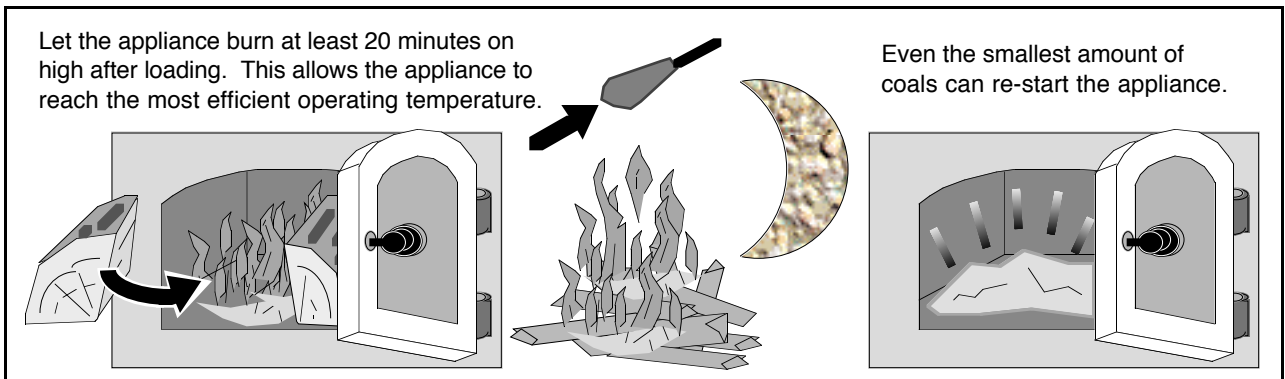

**Good Burning Habits**

Increased efficiency, reduced emissions, and less creosote are the rewards of good burning habits.. The items below list good habits to establish with your new appliance.

- Get the appliance hot before turning it down
- Use smaller pieces of wood during start-up and high burns to increase temperature
- Use larger pieces of wood for overnight or sustained burns
- Stack the wood tightly together to establish a longer burn
- Leave a bed of ashes (1/2" deep) to allow for longer burns
- Be considerate of neighbors & the environment: burn dry wood only
- Burn small, intense fires instead of large, slow burning fires when possible
- Learn your appliance's operating characteristics to obtain optimum performance

**NOTE:** A stove thermometer gives you a good indication of how hot your appliance is burning when placed directly on top of the appliance. Low burn is approximately 300 degrees F., medium burn 500 to 600 degrees F., and high burn 700 to 800 degrees F.

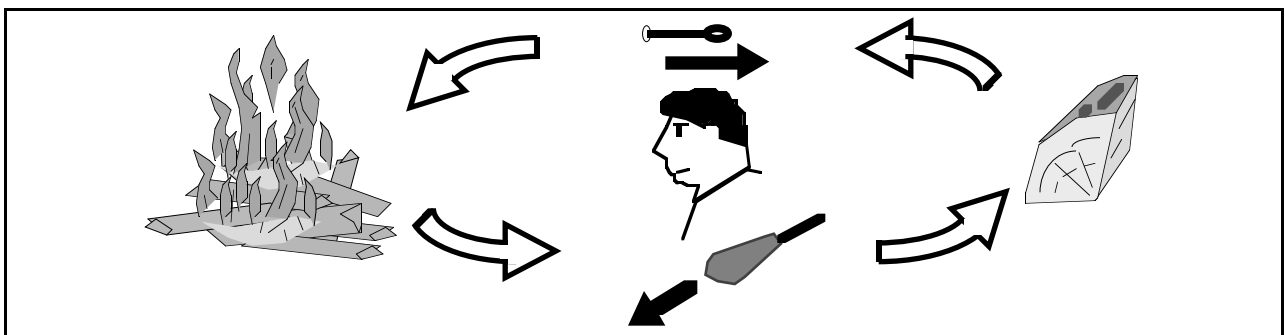

## **BLOWER OPERATION**

The blower assists the convection chamber in distributing heat to your home. The directions below detail the options you have with the blower and the best method for operation.

### **What turns the blower on**

The blower includes a heat-sensing device that does not allow the blower to turn on until the appliance is up to temperature. Once up to temperature, the blower will operate at the speed determined by the position of the blower knob (see the illustration below). The blower shuts off once the appliance cools.

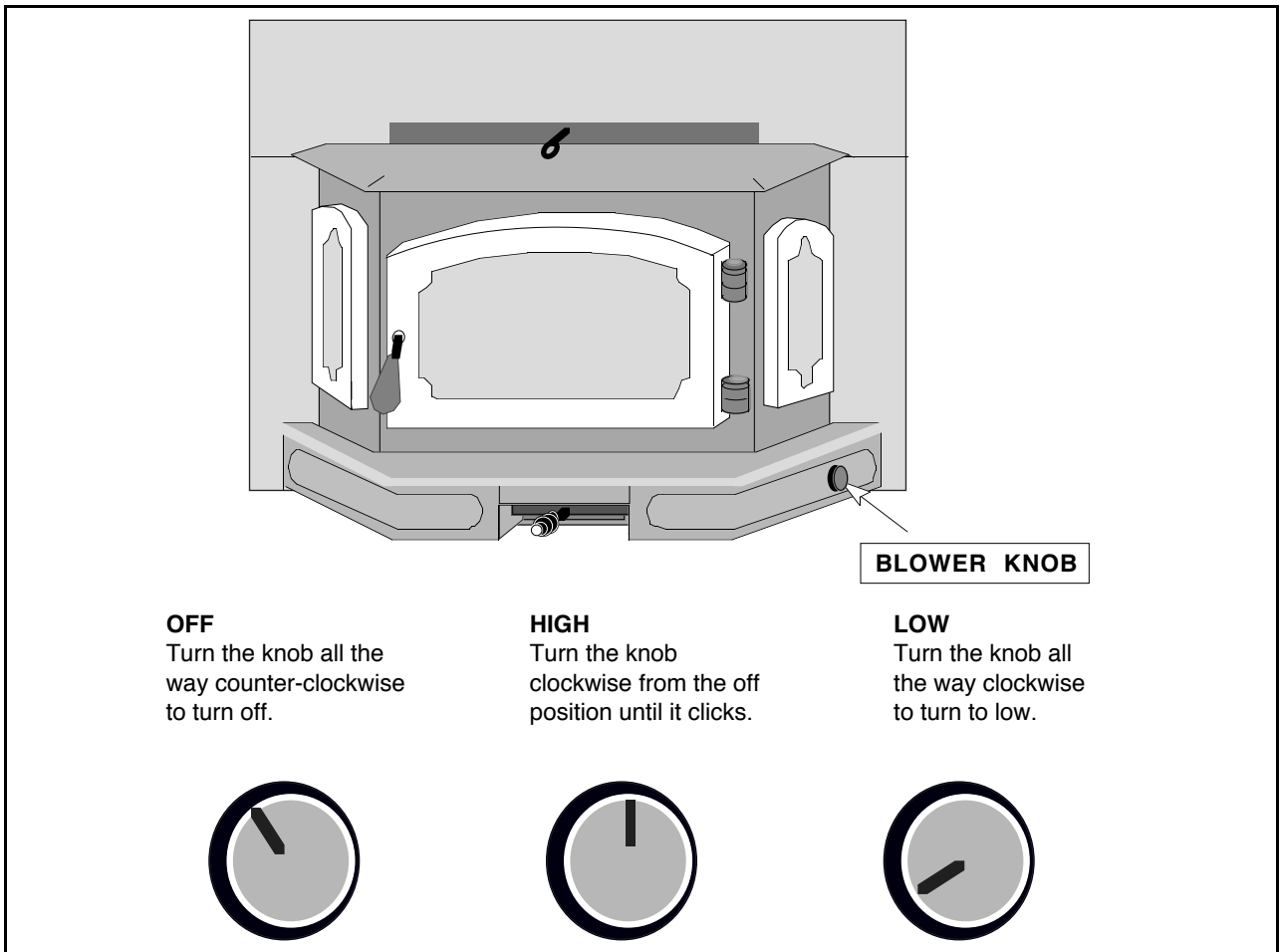

### **How to Use the Blower to Regulate Heat**

Turn the blower to high if the room needs heat and the appliance is up to temperature. When the room has reached a high enough temperature, turn the blower off to stop the heat transfer. Used in conjunction with the air control, a steady temperature can be achieved.

**A WORD ABOUT WOOD**

This appliance is designed to burn natural cord wood with high efficiencies and low emissions. With properly dried wood, you will fully realize the heating and clean-burning potential of our high-technology appliance. With poor wood, this high-technology appliance will become much less efficient and produce more emissions. Read on to find out more about the type of fuel you should use.

**The Drier the Better**

The most common mistake made by wood-burners is using wet, green, or un-seasoned fuel. Ask any experienced wood-burner, and he or she will tell you the importance of dry wood. The reason is this: wet, green, or un-seasoned wood still has water in it. When the wood burns it must use its heat energy to evaporate the water. This robs your home of heat (it also leads to greater smoke and creosote due to lesser firebox temperatures). Dry wood usually has cracks in the grain. It will also be lighter and when two pieces are knocked together a crisp "knock" will be heard, not a dull "thud". When burning green, wet, or unseasoned wood you may notice difficulty in lighting, and water bubbling out of the grain when it becomes hot.

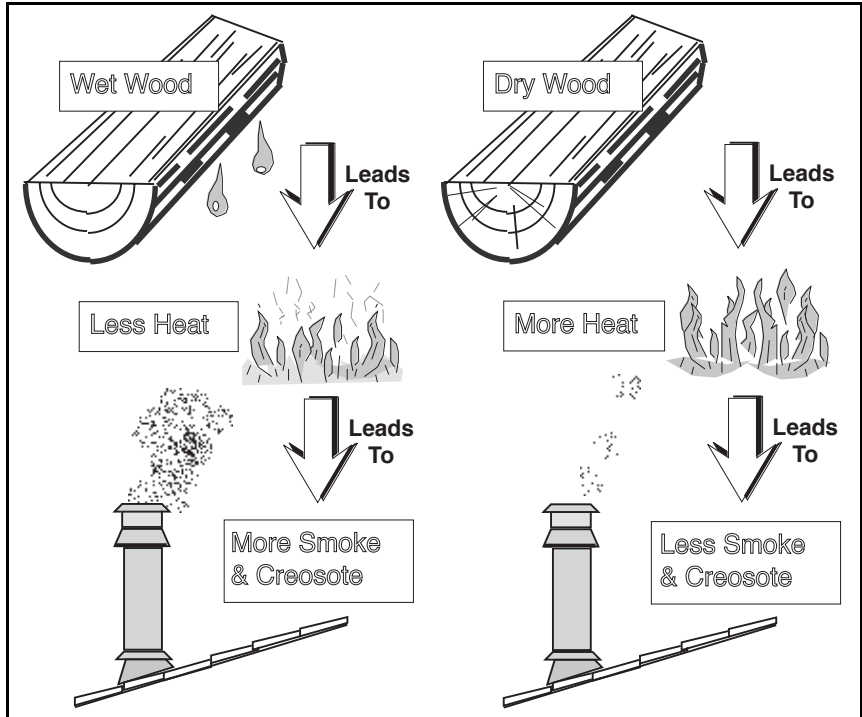

**How to Dry and Store Wood**

Aging is the only economical method for drying wood. Follow the steps below to dry and store wood:

1. Make sure the wood is split into quarters and is no longer than 18" long (Hint: if you cut trees in summer, leave the leaves on for a week, this will draw moisture from the wood to dry it quicker).
2. Stack the wood in loose piles that are covered and off the ground (this is to allow air to pass over each piece of wood – promoting faster drying) If no shelter is built, place clear polyethylene plastic over the wood (at an angle to allow moisture to run off). Let dry for at least one year.
3. Store the wood in a dry location, preferably outside to prevent insects and dirt from entering the home. When needed, move small loads inside where the added heat will promote further drying.

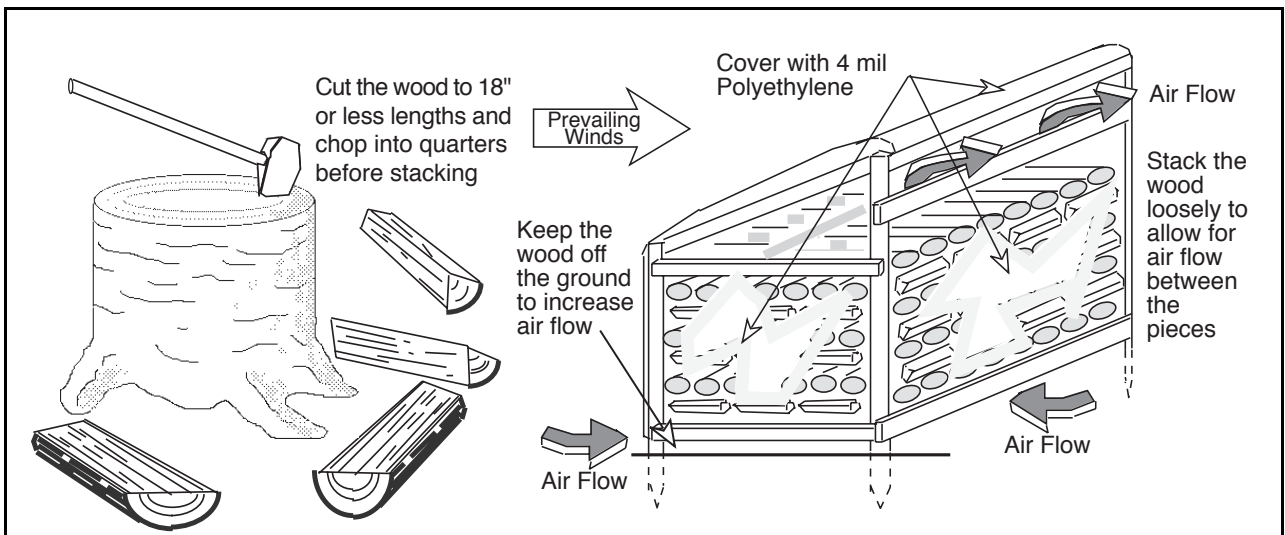

**A WORD ABOUT WOOD (CONTINUED)**

**Constructing a Wood Shed**

The drawing to the right details the construction of an inexpensive wood shed that will promote drying, increasing the heat output from your wood.

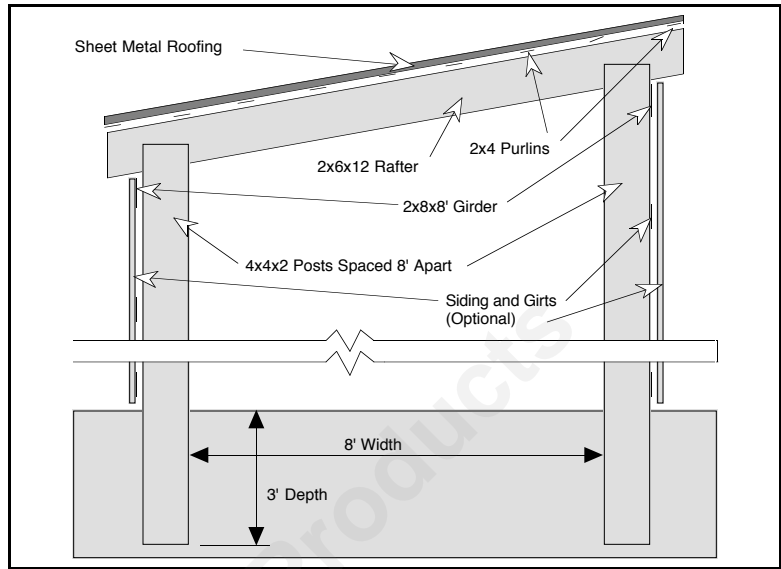

**What Type of Wood is Best**

Choosing the kind of firewood to burn in your appliance depends on what is available to you. Softwoods, such as pine or fir ignite and burn quicker, but require more frequent loadings and are less suited for overnight burns. For longer burns, with less frequent loadings, we recommend harder woods such as oak or maple. The chart below details the BTU (heat) output of the various species. Note the higher BTU output of the harder woods. The best arrangement is to have softwoods for starting and immediate heating and hardwoods for overnight and sustained burns.

SPECIES (20% moisture)	LBS./CORD (Approximate)	BTU's/CORD (Approximate)	Hours per Cord at 40,000 BTU's per Hour (Approximate)
ALDER	2540	19,050,000	476
APPLE	4400	33,000,000	825
ASH	3440	25,800,000	645
BIRCH	3040	22,800,000	705
CEDAR	2060	15,450,000	386
COTTONWOOD	2160	16,200,000	405
DOGWOOD	4320	31,725,000	793
ELM	2260	16,950,000	423
FIR, DOUGLAS	2970	22,275,000	556
HEMLOCK	2700	20,250,000	506
MAPLE	3200	24,000,000	600
OAK, RED	3680	27,600,000	690
OAK, WHITE	4200	31,500,000	787
PINE	2250	16,875,000	421
REDWOOD	2400	18,000,000	450
SPRUCE	2240	16,800,000	420

**How to Buy Wood**

Wood is sold by the cord (4' wide by 4' high by 8' long). Buy wood in the spring and summer, when prices are lower and it will have plenty of time to dry. If buying in winter, have the wood moisture tested (test several pieces). You will receive up to 25% more heat from a cord of dry wood than from wet or green wood. Rotate your wood so as to allow for the maximum drying time for all pieces.

**Don't Burn Wood Scraps, Garbage, Paper, Wax Logs, Coal, Etc.**

Wood scraps from construction are typically chemically treated, making them difficult to burn and dangerous due to emitting chemicals. The same holds true for garbage, solvents, driftwood containing salt, cardboard, and colored paper. Coal and wax impregnated logs burn especially hot, creating a possible safety hazard. In addition, all the aforementioned items may create excessive creosote.

## **MAINTENANCE SCHEDULE**

Your appliance requires periodic maintenance to work correctly. The steps involved with maintenance are usually quick and easy. Look through this maintenance schedule and plan accordingly.

**WARNING:** Failure to properly maintain and inspect your appliance may reduce the performance and life of the appliance, void your warranty, and create a fire hazard.

**PERIODIC MAINTENANCE** (every week when appliance is in use):

- Remove ash from the firebox (if necessary)
- Clean the viewing glass (if necessary)
- Clean the brass (if necessary)
- Check for creosote buildup in the chimney and connector

**BI-MONTHLY MAINTENANCE** (every two months during the heating season):

- Door and glass inspection
- Lubricate the door hinge

**YEARLY MAINTENANCE** (before every heating season):

- Touch-up paint
- Blower cleaning
- Firebrick and baffle inspection and cleaning

## **REMOVE ASH FROM THE FIREBOX (IF NECESSARY)**

At least once a week while the appliance is in use, check the level of ash on the floor of the firebox. If 1" or more of ash has accumulated, let the appliance cool and place the excess ash into an airtight container away from any structure. After the ash is fully extinguished it may be disposed. A 1/2" to 1" bed of ash is desirable, for it allows the appliance to burn at a slightly lower speed.

**WARNING:** Ashes removed from the appliance must be stored in an airtight container away from any structure until fully extinguished before disposing.

## **CLEAN THE VIEWING GLASS (IF NECESSARY)**

This appliance has an airwash to keep the glass clean. However, burning un-seasoned wood or burning on lower burn rates leads to dirtier glass (especially on the sides). Clean the glass by following the directions below. For especially dirty glass, use fine steel wool to remove build-up.

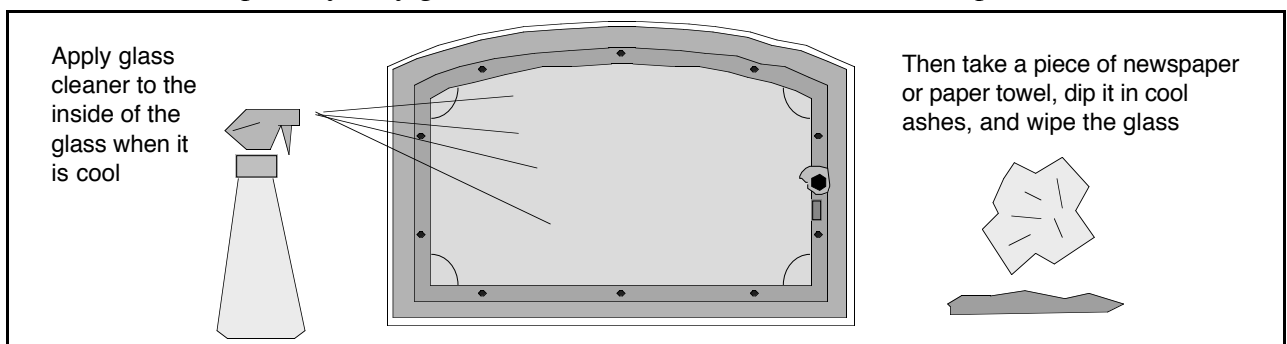

## **CLEAN THE BRASS (IF NECESSARY)**

If your insert has a brass door, it may be cleaned using a non-abrasive polish (such as FLITZ®) when the appliance is cool. The brass trim and ashlip is anodized, and should be cleaned with soap and water.

## **CHECK FOR CREOSOTE BUILDUP**

Creosote buildup should be checked twice monthly during the heating season. Either look down the chimney from the top or remove a chimney connector section. Any more than 1/4" of buildup requires chimney cleaning. Creosote develops quickest when burning at a low temperature or when burning un-seasoned wood. When wood is burned slowly, it produces tar and other vapors which combine with moisture to form creosote. Creosote vapors condense in the relatively cool chimney flue and creosote residue accumulates on the flue lining. When ignited, this creosote makes an extremely hot fire.

## **DOOR AND GLASS INSPECTION**

The door must seal air-tight for the appliance to work correctly. Check the two items below and follow the appropriate remedy to fix any problems.

- Check the door cam operation. When closed, the door cam should pull the door against the face of the appliance, but not be so tight as to not allow the handle to point downwards. If the operation is not correct, see the section "Adjusting the Door Cam" below.
- Remove the door by opening it and lifting it off the hinges. Place the door face down and check the door gasket (see the illustration below). If the door gasket requires replacement, see the section "Replacing the Door Gasket" on the following page. Check the glass and glass gasket. If the glass or gasket require replacement, see the section "Replacing the Glass or Glass Gasket" on the following page.

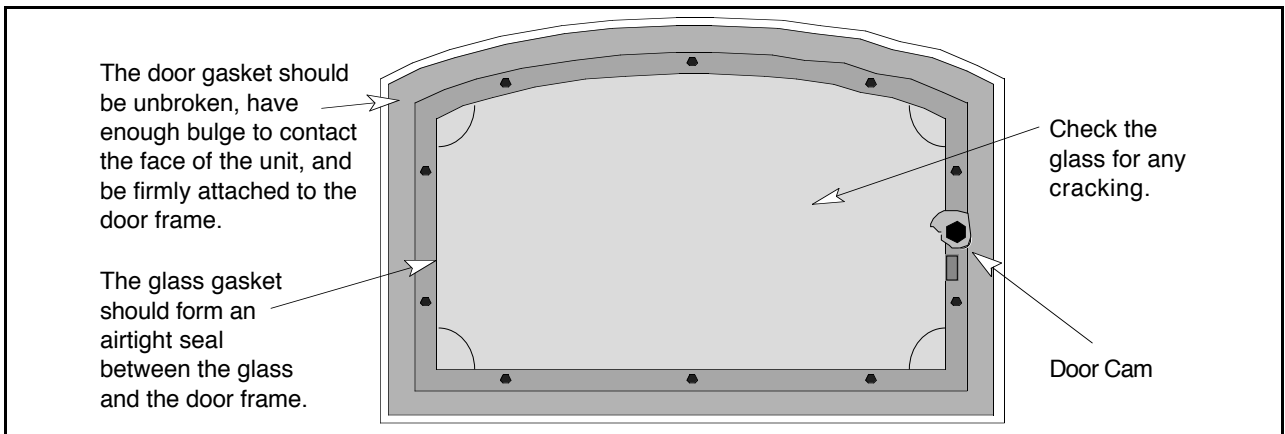

## **Adjusting the Door Cam**

If the door cam does not pull the door against the face of the appliance, the door cam will need to be tightened (see the illustration below for details). If the door handle does not turn down all the way, it is too tight and will need to be loosened (see the illustration below for details). Before adjusting, remove the door by opening the door and lifting it off the hinges.

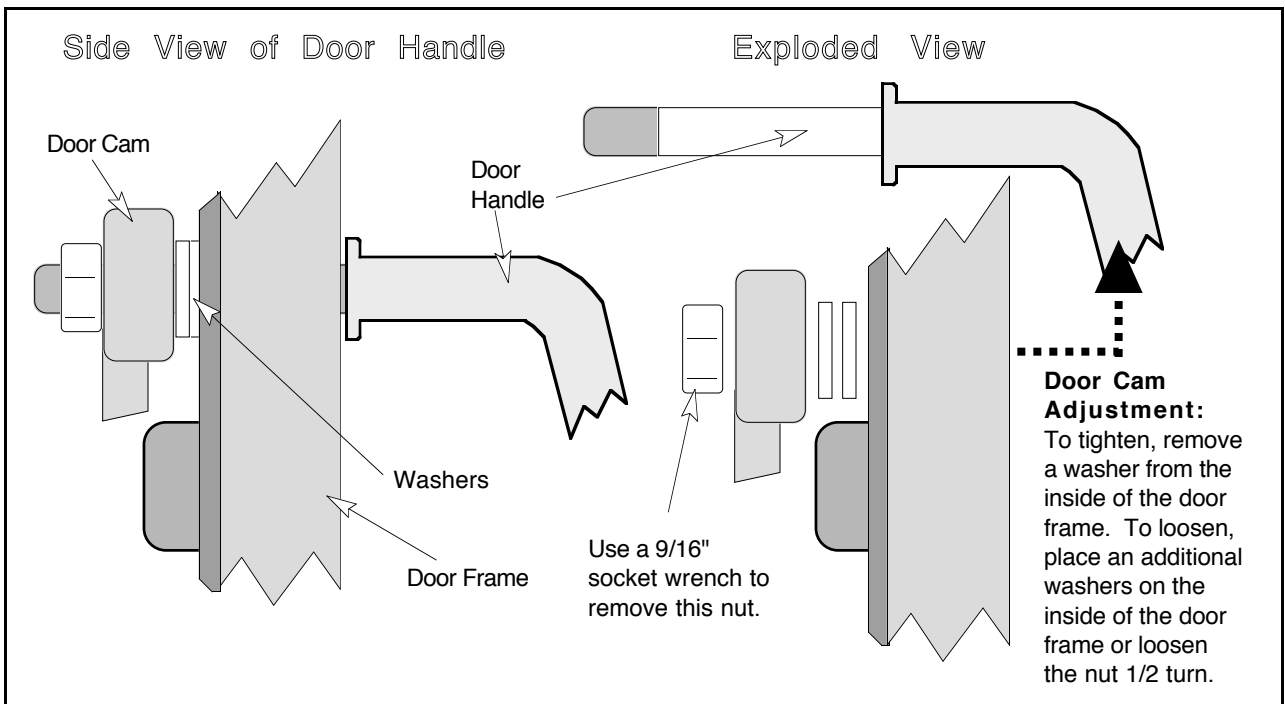

**Replacing the Door Gasket**

Remove the door by opening it and lifting it off the hinges. Remove the old gasket by stripping it away with a screwdriver or other tool (see the illustration below). Apply a line of gasket cement (available from your dealer) in the groove that follows the perimeter of the door. Insert the gasket into the groove. Do not stretch the gasket as you place it into the groove. Cut off any excess gasket when done. Allow 2 hours for the cement to dry. When re-installing the door, the gasket may need to be flattened by repeatedly opening and closing the door.

**Replacing the Glass or Glass Gasket**

Remove the door by opening it and lifting it off the hinges. Remove the door handle from the door. Then remove the glass retainer by unscrewing the ten screws that hold it in place with a 5/16" nutdriver (see the illustration below). Carefully remove the glass. Make sure the 3/4" black channel tape (new or old) runs around the perimeter of the glass. If using a new gasket, trim off any excess. Place the glass (new or old) in place so there is a small gap between the edge of the glass and the door frame. Make sure the gasket is tucked underneath the glass so the glass does not touch the door frame. Place the glass retainer in place and secure it with the screws removed earlier. Make sure the white gasket stays in place and seals the window. Tighten the glass retainer until the gaskets start to flatten.

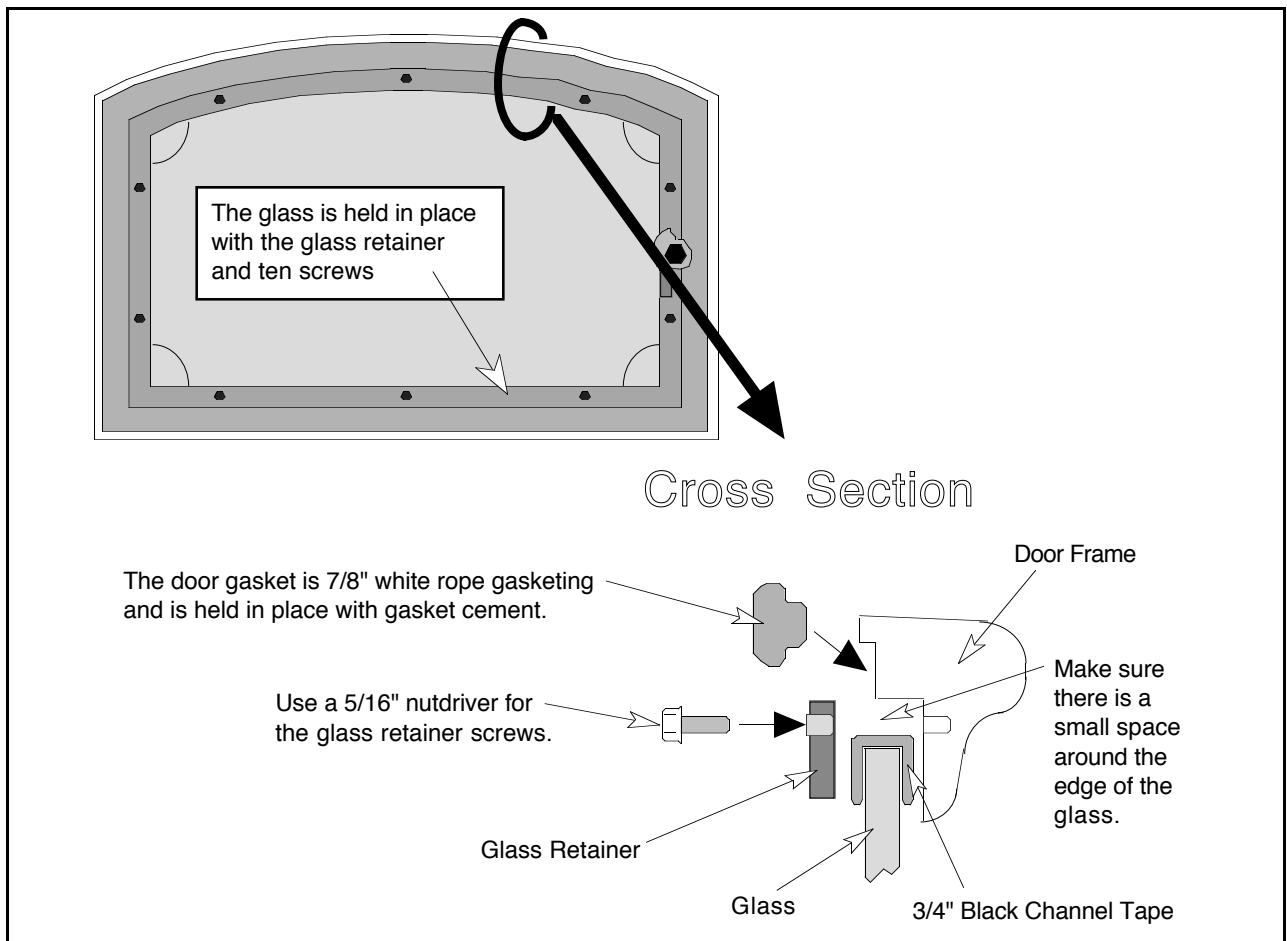

**LUBRICATE THE DOOR HINGE**

Periodically lubricate the door hinges with a high temperature lubricant (such as Permatex Industrial® Anti-Seize). Lubricating the door involves removing the door by opening it and lifting it off the hinges, and placing lubricant on the hinge pins.

### **TOUCH-UP PAINT**

Included with the owner's pack of this appliance is a can of Stove-Brite® paint. To touch up nicks or dulled paint, apply the paint while the appliance is cool. Use 120 grit sandpaper (clean with water and dry with a piece of cloth) if the surface requires smoothing. Wait at least one hour before starting the appliance. The touched up area will appear darker than the surrounding paint until it cures from heat. Curing will give off some fumes while curing – open windows to ventilate the fumes.

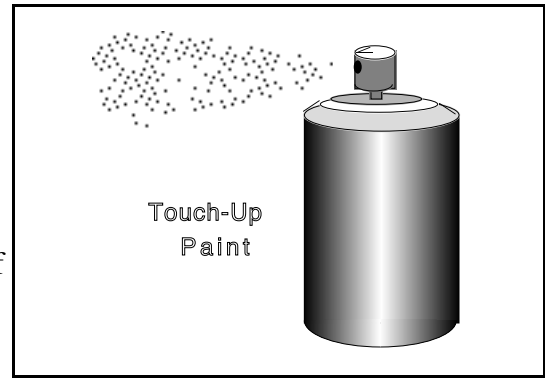

### **BLOWER CLEANING**

The blower for this appliance will gather dust as it circulates air. Before cleaning, remove the blower from the appliance (see "Blower Installation" on page 8). Remove all dust and debris from the blower grill and around the interior of the blower.

### **FIREBRICK AND BAFFLE INSPECTION AND CLEANING**

With the appliance cool, remove all ash from the firebox and scrape away any scale that may have built up on the surface of the firebrick with a wire brush or scraper. Any of the firebrick on the floor or walls of the firebrick that is cracked must be replaced (see the section "Firebrick Removal and Replacement Instructions"). Next, inspect the baffle components. The illustration below details the areas that must be inspected. If any of the components need to be replaced, see the section "Baffle Removal and Replacement Instructions".

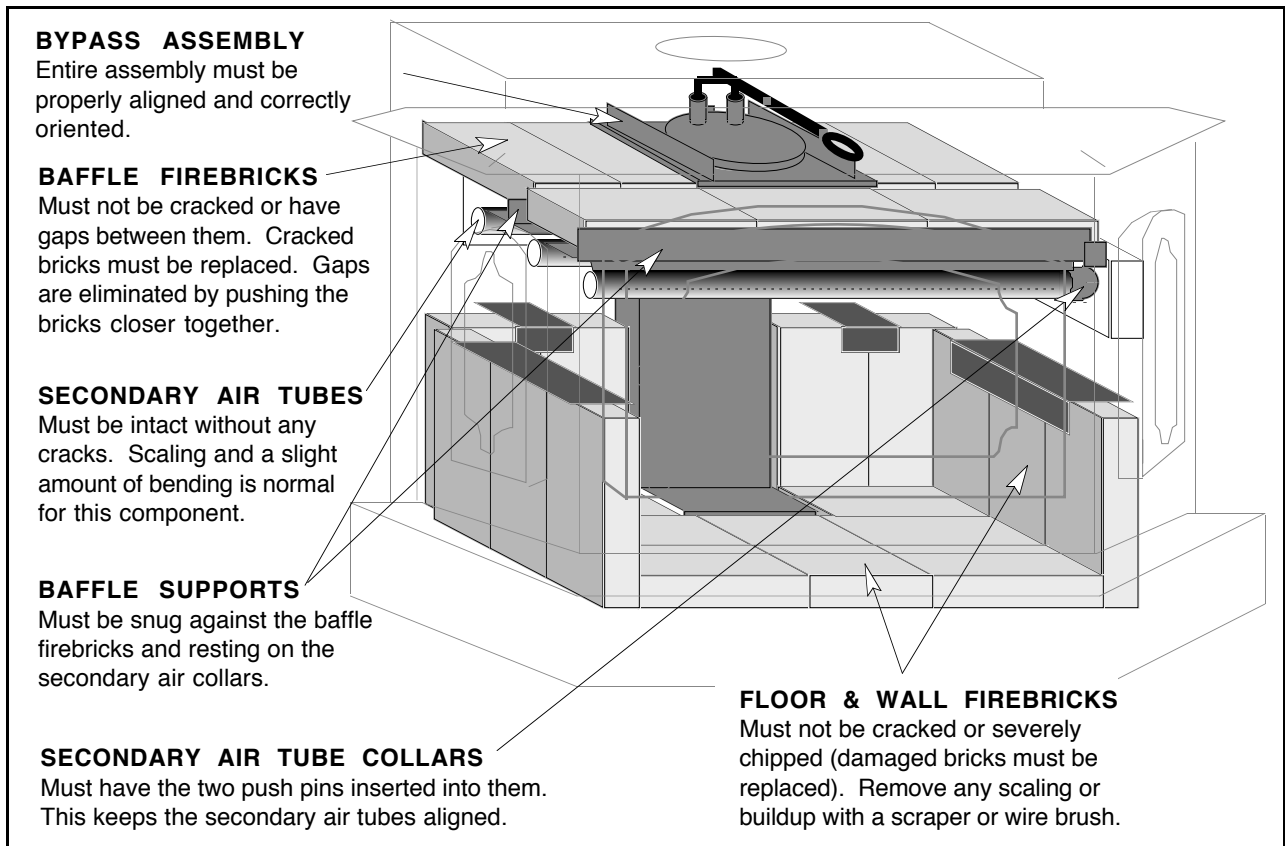

**Firebrick Removal and Replacement Instructions**

With the appliance cool, remove all ash from the firebox. Only the firebrick that is damaged must be replaced. If the damaged firebrick is on the floor, it can be replaced by simply removing the firebrick in front of it. **NOTE: Do not pry firebrick to remove, this will chip or crack the firebrick.** If a firebrick on the wall of the firebox needs replacement, the floor firebrick near it will need to be removed first. The wall firebrick is held upright by a clip on the walls of the firebox. To remove, pivot it out from the bottom. See the illustration below.

**WALL FIREBRICKS**  
First remove the firebricks on the floor in front of the firebrick needing replacement. Then pivot it out from the bottom to clear the clip that holds it in place.

**FLOOR FIREBRICKS**  
Remove the firebricks in front of the firebrick needing replacement.

**FIREBRICK SIZES -**  
All firebrick is 1 1/4" x 4 1/2" x 9" except those labeled.

Firebrick labeled **(A)** are 1 1/4" x 4 1/2" x 6 3/8".

Firebrick labeled **(B)** are 1 1/4" x 4 1/2" x 8 1/4".

**CLIPS -**  
Hold the wall firebrick in place.

**Baffle Removal and Replacement Instructions**

The view below details the baffle components. Instructions for removal are on the following page.

Bypass Rod - threaded in two locations for easy removal

Bypass Damper

Bypass Handle

Baffle Firebrick

Center Baffle Support

Forward Baffle Support

Bypass Support - note its orientation and how it rests on the rear baffle firebrick

Baffle supports rest on these tabs

**Baffle Removal and Replacement Instructions (continued)**

All of the baffle components are removable to facilitate easy cleaning and repairs. Make sure the appliance is cool before removing any of the components. See the instructions on the following page for removing the secondary air tubes.

**REMOVING BAFFLE COMPONENTS**

1. Lift up on the front portion of the front three firebricks.

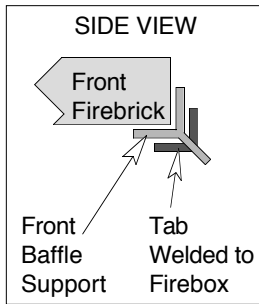

2. Lift the front baffle support and rotate it forward until it can be removed.

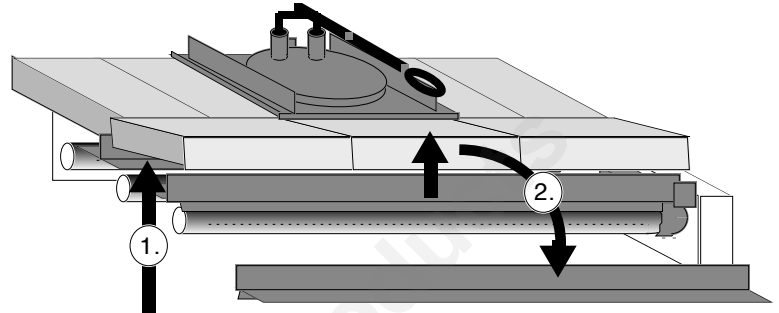

3. Slide the center front firebrick forward and out the door opening. Then slide the side front firebricks towards the middle then out in the same manner.

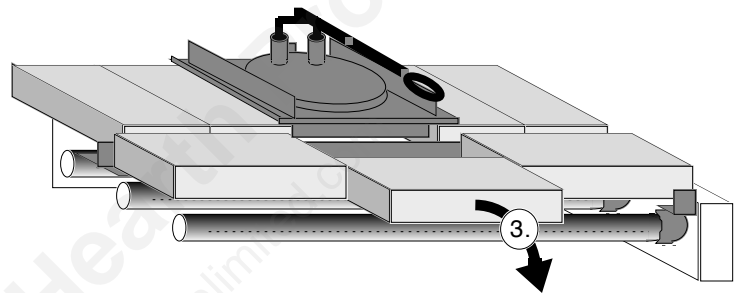

4. Slide the center baffle support forward and out of the firebox.

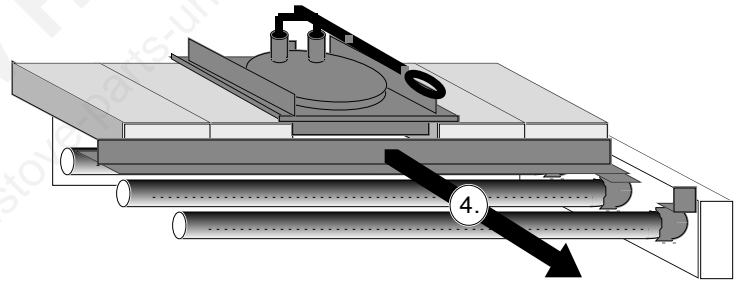

5. Slide the rear firebrick forward and out of the firebox. NOTE: When the center rear firebrick are slid forward the baffle support will come to rest on the rear secondary air tube and rear air channel.

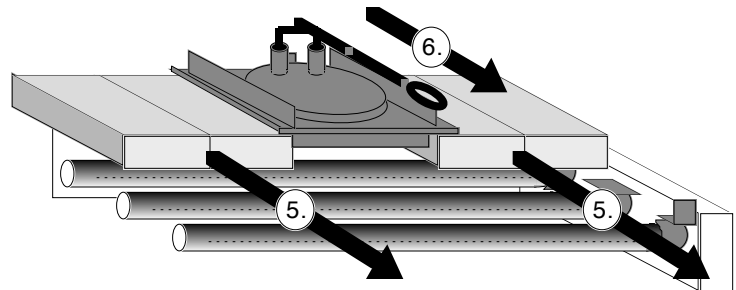

6. Slide the bypass all the way forward.

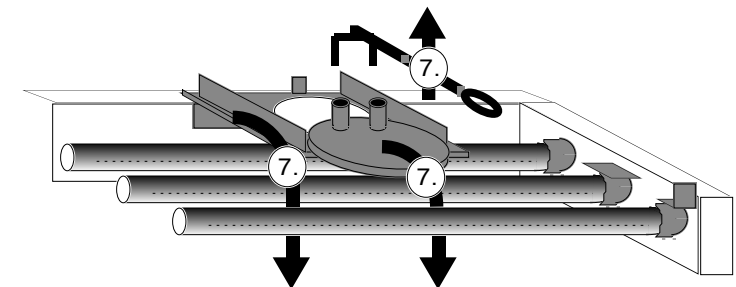

7. Reach into the firebox and push up on the bypass rod until the bypass damper separates from the bypass rod. Remove both the bypass damper and bypass assembly by sliding them between the front two secondary air tubes.

**REPLACEMENT INSTRUCTIONS:**

- A. Place the bypass support above the secondary air tubes in the rear center of the firebox.
- B. Position the bypass damper so the bypass rod inserts into the two tubes on the bypass damper (make sure to have correct orientation). Then slide the bypass damper over the bypass support until both are centered in the firebox.
- C. Follow the instructions above in reverse order, starting with step number 5.

### Secondary Air Tube Replacement Instructions

**REMOVING THE SECONDARY AIR TUBES**  
Follow the directions to the right to remove any of the three secondary air tubes.

**NOTE:** When replacing, make sure the two holes on the secondary air tube sleeve line up with the hole on the secondary air tube and the hole on the air tube stub welded to the side air channel.

Pry out both pins on the secondary air tube sleeve (use a screwdriver).

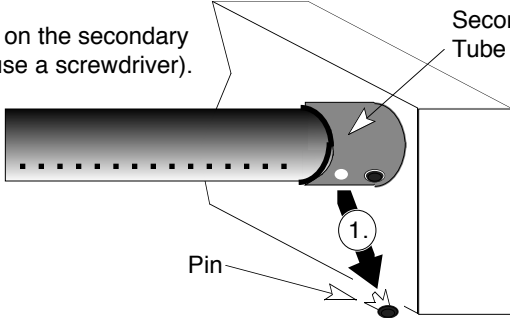

Slide the secondary air tube sleeve to the left.

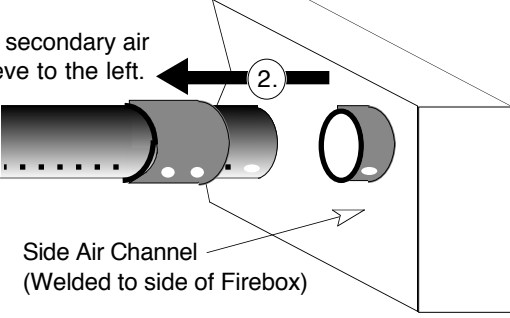

Slide the secondary air tube to the right until it disengages from the left side.

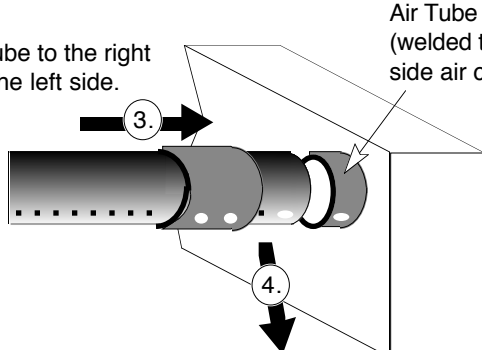

### REPLACEMENT PARTS LIST

PART	PART DESCRIPTION
Door Gasket	Black 7/8" dia. Fiberglass rope 64" long
Glass Gasket	Black 3/4" x 1/8" fiberglass channel tape 60" long
Door Glass	5 mm neoceram, 11 7/8" tall @ center, 19 1/4" wide
Retainer for Door Glass	Cast steel retainer attaches to door with ten screws (included)
Handle for Door	Brass spring (1/2")
Door Handle	Steel shaft with threaded end (includes spring handle)
Door Cam	Cast brass
Air Control Handle	Brass spring (3/8")
Firebrick	1 1/4" x 4 1/2" x 9" silicon based refractory - some firebrick will require cutting
Secondary Air Tube	22 7/8" long with 3/16" holes every 3/4", includes two pins
Front Baffle Support	23 5/8" long, 1 1/2" angle iron welded to 21 1/8" long 1" deflector at 45° angle
Center Baffle Support	23 5/8" long, 1 1/2" angle iron welded to 23 5/8" long 1" strip to form a "t"
Bypass Support	9" by 9" square 5/16" thick with two 7 1/4" x 1" guides top & bottom, stop
Bypass Damper	6 11/16" dia. Circle of 5/16" thick steel, two 1" tubes welded to top for yoke
Bypass Yoke and Bypass Extender	All 3/8" dia. Rod, 6" (before bending) yoke welded to 7" rod, + 7" extender
Bypass Handle	Cast iron eye bolt
Owner's Manual	This document
Air Control Slider	Steel plate with air control rod
Air Control Floating Plate with Springs	8 springs and the floating plate used to guide air control slider
Bypass Pull Tool	Tool used to adjust bypass

<b>Problem:</b>	<b>Possible Cause:</b>	<b>Remedy:</b>
<b>Smoke Spills From Door When Loading</b>	• Door was opened before the air control was pushed in	Pull the air control all the way out a few seconds before opening the door.
	• Door was opened before the bypass was pulled out	Pull the bypass all the way out before opening the door (see "Bypass Control" on page 13)
	• Door was opened too quick	Door should be opened a crack to allow air to enter before opening all the way (see "How to Reload your Appliance" on page 14).
	• Draft is not adequate	Your installer or dealer can give you more information on draft. The most common causes of low draft are a short, offset, or small chimney, an external down draft due to wind, an extremely air-tight home with exhaust fans, or a thermal down draft due to appliance placement.
<b>Kindling Does Not Start</b>	• Cold air block in chimney	A cold air block keeps the appliance from establishing a draft. First ignite a piece of newspaper in the appliance before starting the kindling.
	• Kindling is wet or too large to light	Kindling must ignite quickly to be effective. Wet or large kindling will make starting very difficult.
	• Bypass was closed	Pull the bypass all the way out before starting the appliance (see "Bypass Control" on page 13).
<b>Appliance Does Not Put Off Much Heat</b>	• Wood is wet, unseasoned, or green	Wet wood will give off much less heat than dry, seasoned wood (see "A Word about Wood" on page 17).
	• Appliance requires time to warm up	The appliance will not give off heat until it has been burning on high for at least one half hour (see "Learning to Burn your Appliance" on page 13).
	• Bypass was open	The bypass should be closed once the fire is established to increase the appliance's efficiency (see "Bypass Control" on page 13).
<b>Appliance Does Not Burn Overnight</b>	• Wood is fast burning	Lighter, faster burning woods (e.g. alder, pine) are less suited for overnight burns (see "A Word about Wood" on page 17)
	• Wood is in small pieces	Wood should be large to facilitate a slower burn (see "How to Achieve an Overnight Burn" on page 15).
	• Check for coals - there may be some there	Even a small amount of coals are enough to start a new fire if kindling is placed on top.
<b>Appliance Does Not Burn Fast On High</b>	• Draft is low	Your installer or dealer can give you more information on draft. The most common causes of low draft are a short, offset, or small chimney, an external down draft due to wind, an extremely air-tight home with exhaust fans, or a thermal down draft due to appliance placement.
	• Wood is wet	Wet wood will give off much less heat than dry, seasoned wood (see "A Word about Wood" on page 17).
	• Appliance is cool	New high-tech. appliances have a lag time between adjusting the air control and the fire speeding up.
<b>Blower Does Not Turn On</b>	• Appliance is not hot enough yet	Appliance must be up to temperature for the blower to turn on if it is turned to "AUTO" (see "Blower Operation" on page 16).
	• Blower is not plugged in or circuit is off	Check the outlet that the blower is plugged into with a lamp to see if it has power.
<b>Smoke Is Dirty From Chimney</b>	• When reloading or starting, smoke is higher than normal	The fire is evaporating the water from the wood, giving off more visible smoke.
	• Wood is wet	Wet wood will give off much more smoke than dry, seasoned wood (see "A Word about Wood" on page 17).

To register your TRAVIS INDUSTRIES, INC. 7 Year Warranty, complete the enclosed warranty card and mail it within **ten (10)** days of the appliance purchase date to: TRAVIS INDUSTRIES, INC., 10850 117th Place N.E., Kirkland, Washington 98033. TRAVIS INDUSTRIES, INC. warrants this appliance (appliance is defined as the equipment manufactured by Travis Industries, Inc.) to be defect-free in material and workmanship to the original purchaser from the date of purchase as follows:

**Years 1 & 2 - COVERAGE: PARTS & LABOR**Firebox Assembly:

Firebox, Baffle Supports, Air Tubes, Air Channels, Convection Chamber

Door Assembly:

Solid Brass or Cast Door, Latch Assembly, Glass Retainers

Air Control Assembly

Slider Plate, Pressure Plate

**Exclusions:** Paint, Gasketing

Ceramic Glass

Glass (breakage from thermal shock)

Firebrick

Breakage from thermal shock

Accessories

Legs, Pedestal, Panels, Blower

RE-INSTALLATION ALLOWANCE

In cases where heater must be removed from home for repairs, a partial cost of re-installation is covered (pre-authorization required)

ONE-WAY FREIGHT ALLOWANCE

One-Way Freight Allowance On Pre-Authorized Repair Done At Factory Is Covered.

**Years 3 Through 5 - COVERAGE: PARTS & LABOR**Firebox Assembly:

Firebox, Baffle Supports, Air Tubes, Air Channels, Convection Chamber

Air Control Assembly

Slider Plate, Pressure Plate

**Exclusions:** Paint, Gasketing, Accessories (Legs, Pedestal, Panels, Blower), Glass, Firebrick, Re-Installation Allowance

Door Assembly:

Solid Brass or Cast Door, Latch Assembly, Glass Retainers

ONE-WAY FREIGHT ALLOWANCE

ONE-Way Freight Allowance On Pre-Authorized Repair Done At Factory Is Covered.

**Years 6 & 7 - COVERAGE: PARTS ONLY**Firebox Assembly:

Firebox, Baffle Supports, Air Tubes, Air Channels, Convection Chamber

Door Assembly:

Solid Brass or Cast Door, Latch Assembly, Glass Retainers

Air Control Assembly

Slider Plate, Pressure Plate

**Exclusions:** Paint, Gasketing, Accessories (Legs, Pedestal, Panels, Blower), Glass, Firebrick, Re-Installation Allowance, One-Way Freight Allowance, Labor

**CONDITIONS & EXCLUSIONS**

- This new appliance must be installed by a qualified installer. It must be installed, operated, and maintained at all times in accordance with the instructions in the Owner's Manual. Any alteration, willful abuse, accident, neglect, or misuse of the product shall nullify this warranty.
- This warranty is nontransferable, and is made to the ORIGINAL purchaser, provided that the purchase was made through an authorized Travis dealer.
- Discoloration and some minor expansion, contraction, or movement of certain parts and resulting noise, is normal and not a defect and, therefore, not covered under warranty. Over-firing (operation where the steel may glow red) of this appliance can cause serious damage and will nullify this warranty.
- The warranty, as outlined within this document, does not apply to the chimney components or other Non-Travis accessories used in conjunction with the installation of this product. If in doubt as to the extent of this warranty, contact your authorized Travis retailer before installation.
- Travis Industries will not be responsible for inadequate performance caused by environmental conditions such as nearby trees, buildings, roof tops, wind, hills or mountains or negative pressure or other influences from mechanical systems such as furnaces, fans, clothes dryers, etc.
- This Warranty is void if:
  - The unit has been operated in atmospheres contaminated by chlorine, fluorine or other damaging chemicals.
  - The unit is subject to submersion in water or prolonged periods of dampness or condensation.
  - Any damage to the unit, combustion chamber, heat exchanger or other components due to water, or weather damage which is the result of, but not limited to, improper chimney/venting installation.
- Exclusions to this 7 Year Warranty include: injury, loss of use, damage, failure to function due to accident, negligence, misuse, improper installation, alteration or adjustment of the manufacturer's settings of components, lack of proper and regular maintenance, damage incurred while the appliance is in transit, alteration, or act of God.
- This 7 Year warranty excludes damage caused by normal wear and tear, such as paint discoloration or chipping, worn or torn gasketing, chipped or cracked firebrick, etc. Also excluded is damage to the unit caused by abuse, improper installation, modification of the unit, or the use of fuel other than that for which the unit is configured (use cord wood only).
- Damage to brass surfaces caused by fingerprints, scratches, melted items, or other external sources left on the brass surfaces from the use of abrasive cleaners is not covered in this warranty.
- TRAVIS INDUSTRIES, INC. is free of liability for any damages caused by the appliance, as well as inconvenience expenses and materials. Incidental or consequential damages are not covered by this warranty. In some states, the exclusion of incidental or consequential damage may not apply.
- This warranty does not cover any loss or damage incurred by the use or removal of any component or apparatus to or from the Travis appliance without the express written permission of TRAVIS INDUSTRIES, INC. and bearing a TRAVIS INDUSTRIES, INC. label of approval.
- Any statement or representation of Travis products and their performance contained in Travis advertising, packaging literature, or printed material is not part of this 7 year warranty.
- This warranty is automatically voided if the appliance's serial number has been removed or altered in any way. If the appliance is used for commercial purposes, it is excluded from this warranty.
- No dealer, distributor, or similar person has the authority to represent or warrant Travis products beyond the terms contained within this warranty. TRAVIS INDUSTRIES, INC. assumes no liability for such warranties or representations.
- Travis Industries will not cover the cost of the removal or re-installation of hearths, facing, mantels, venting or other components.
- If for any reason any section of this warranty is declared invalid, the balance of the warranty remains in effect and all other clauses shall remain in effect.
- This 7 year warranty is the only warranty supplied by Travis Industries, Inc., the manufacturer of the appliance. All other warranties, whether express or implied, are hereby expressly disclaimed and purchaser's recourse is expressly limited to the warranties set forth herein.

**IF WARRANTY SERVICE IS NEEDED:**

- If you discover a problem that you believe is covered by this warranty, you **MUST REPORT** it to your Travis dealer **WITHIN 30 DAYS**, giving them proof of purchase, the purchase date, and the model name and serial number.
- Travis Industries has the option of either repairing or replacing the defective component.
- If your dealer is unable to repair your appliance's defect, he may process a warranty claim through TRAVIS INDUSTRIES, INC., including the name of the dealership where you purchased the appliance, a copy of your receipt showing the date of the appliance's purchase, and the serial number on your appliance. At that time, you may be asked to ship your appliance, freight charges prepaid, to TRAVIS INDUSTRIES, INC. TRAVIS INDUSTRIES, INC., at its option, will repair or replace, free of charge, your appliance if it is found to be defective in material or workmanship within the time frame stated within this 7 year warranty. TRAVIS INDUSTRIES, INC. will return your appliance, freight charges (years 1 to 5) prepaid by TRAVIS INDUSTRIES, INC., to your regional distributor, or dealership.
- Check with your dealer in advance for any costs to you when arranging a warranty call. Dealers may require you to pay a service or trip charges for any warranty work. This charge can vary from store to store.

The data on the label below matches the data on the label attached to the side of your insert.



**Warnock Hersey**  
NER-QA219.TL-116

**DO NOT REMOVE THIS LABEL**  
Listed Solid Fuel Burning Appliance  
Suitable for use in masonry fireplaces.



**ENERGY SYSTEMS**

---

**MODEL:**  
**FREEDOM BAY** (FLUSH BAY-96)

Tested to: UL-1482/UL-907

**SERIAL NUMBER**

Report No. 6009 (May 1994)

---

**PREVENT HOUSE FIRES** - Install and use only in accordance with the manufacturer's installation and operating instructions. Contact your local building or fire officials about restrictions and installation inspection in your area. Refer to local building codes and manufacturer's instructions for precautions required for passing a chimney through a combustible wall or ceiling. Do not run a chimney connector through a combustible wall or ceiling. Do not connect this unit to a chimney flue serving another appliance. Clearances may be reduced by methods specified in NFPA 211, listed wall shields, pipe shields, or other means approved by local building or fire officials.

**Minimum Clearances to Combustible Materials Fireplace Insert Installation**

Freedom Bay	
K. Mantle	32.0 in.
with Mantle Shield	19.0 in.
L. Top Facing	30.0 in.
with Shield	17.0 in.
M. Adjacent Sidewall	15.0 in.
N. Side Facing	13.5 in.

**Insert Clearance Diagram**

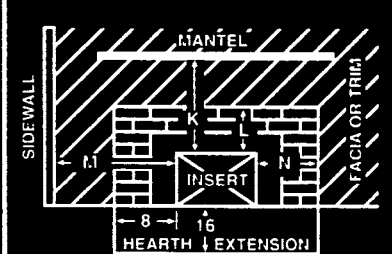

Front 16.0 in.  
Sides 8.0 in.

---

**COMPONENTS REQUIRED FOR MASONRY FIREPLACE INSTALLATION:**  
Surround Panels.

Direct flue connection is optional. Do not remove bricks or mortar from masonry fireplace.

Note: Replace glass with 5mm neoceramic or ceramic glass only.

For use with solid wood fuels only. Operate only with feed door closed - open to feed fire only. Do not use a grate or elevate fire - build fire directly on the hearth.

---

Manufactured By:  **Travis Industries, Inc.**  
10850 117th Pl. N.E. Kirkland, WA 98033

---

U.S. ENVIRONMENTAL PROTECTION AGENCY  
Certified to comply with July 1990 particulate emission standards.

Date of Manufacture

1997 1998 1999 Jan. Feb. Mar. Apr. May June July Aug. Sept. Oct. Nov. Dec.



**DO NOT REMOVE THIS LABEL**      Made in U.S.A.

**SURROUND PANEL INSTALLATION (SEE TABLE BELOW FOR PART NUMBER)**

Surround panel size is determined by the type of installation and the size of the fireplace opening. Direct and positive connections do not require insulation or panels that overlap the fireplace opening (panels that overlap the fireplace opening are usually more attractive). Face seal connections require surround panels that overlap the fireplace opening on the top and sides at least 2" (2 1/2" for rough surfaces). This overlap is needed for the insulation that forms the airtight seal between the surround panels and the fireplace. Any questions on selection of the surround panels should be directed towards your dealer. The table below details the size of the surround panels when installed.

SURROUND PANEL SIZE	SIZE ON APPLIANCE (Including Trim)	PART #
8"	45 3/8" width by 29 1/2" height	99300104
10"	49 3/8" width by 31 1/2" height	99300105
12"	53 3/8" width by 33 1/2" height	99300111

The surround panels should be installed prior to installing the insert. Place the insert 12" from the fireplace opening before installing the surround panels.

1. Follow the directions in the illustration below to install the side panels.

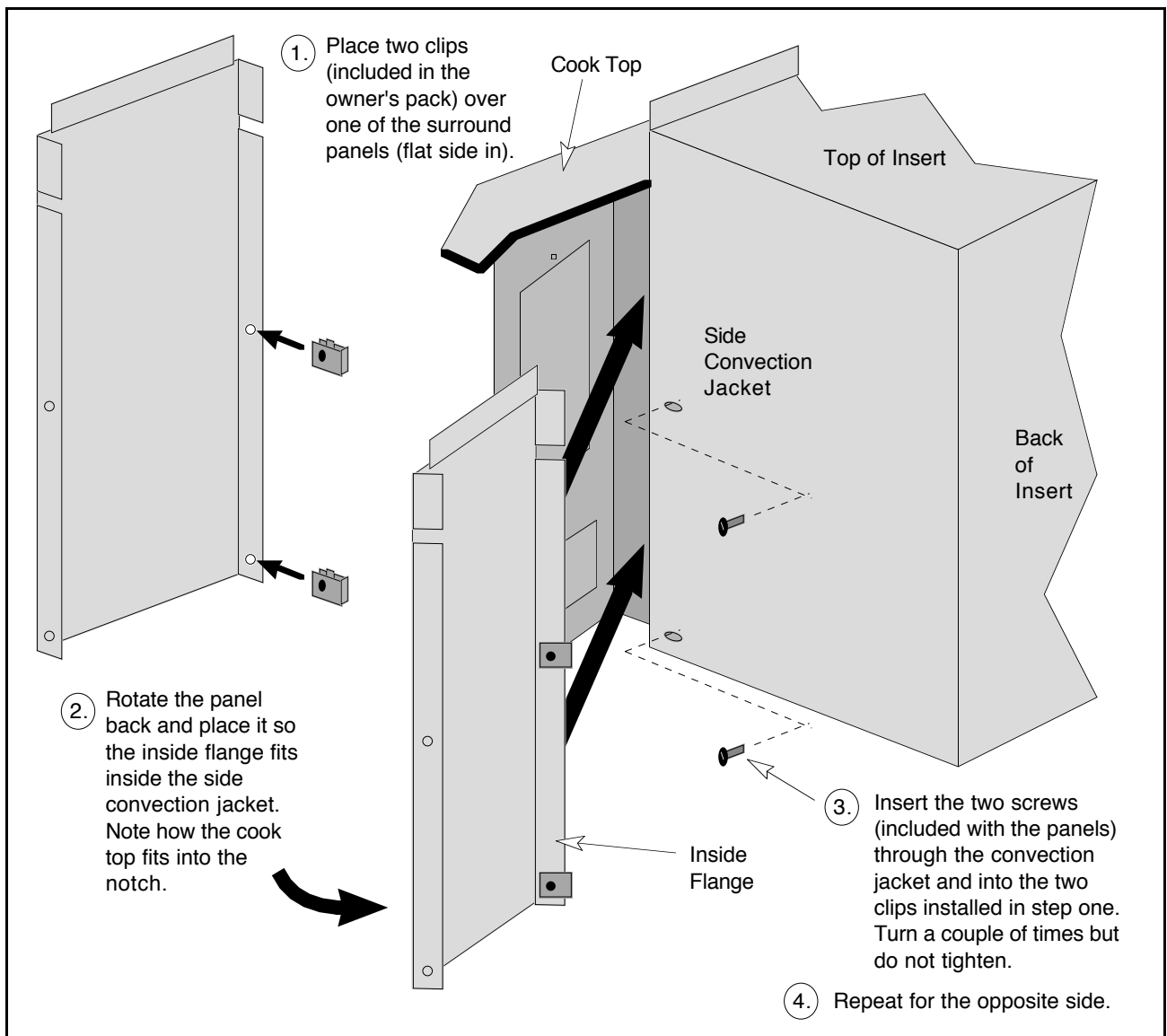

**SURROUND PANEL INSTALLATION (CONTINUED)**

3. Install the top panel (see the illustration below). Adjust the top panel so its edges are flush with the side edges of the side panels.

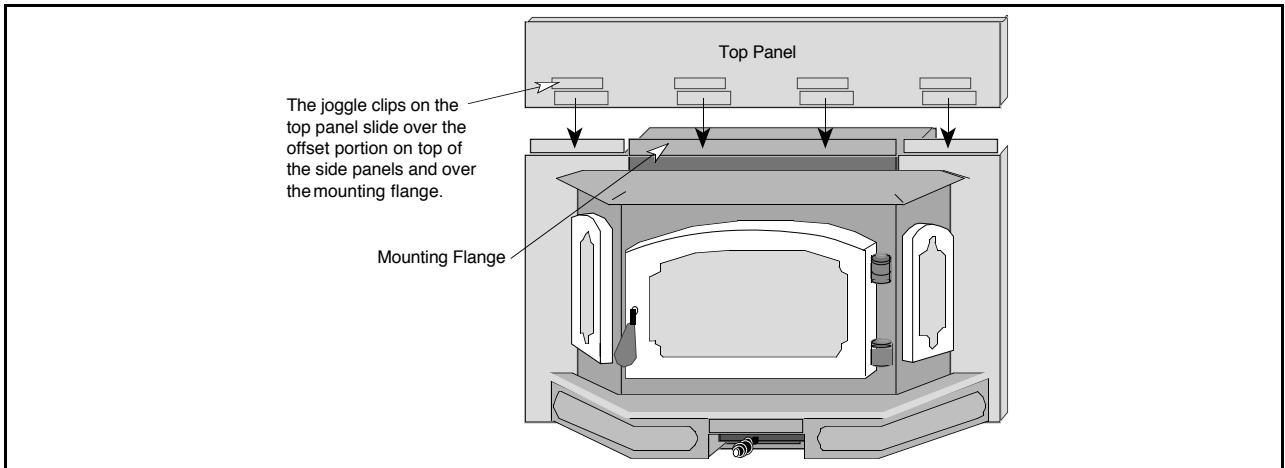

4. Adjust the position of the side panels so they are: 1) flush with the bottom of the insert; 2) both the same distance back from the front of the insert; 3) perpendicular to the floor. Tighten the nuts that hold the side panels in place.

**Insulation Installation**

The installation of the insulation is required only for face seal connections. Direct and positive connections do not require the insulation to be installed.

1. With the insert drawn 12" away from the fireplace, glue the insulation strip included with the surround panel kit to the back of the panels using RTV silicon or stove gasket cement. The insulation should be installed so it overlaps the fireplace opening to form a seal between the panels and the fireplace face. Let the silicon or cement dry.
2. Push the insert into the fireplace, insuring a seal is made with the insulation between the panels and the fireplace face. Use a screwdriver to tuck any exposed insulation behind the panels.

**Brass Trim Installation (Optional)**

The optional surround panel brass trim greatly enhances the appearance of your insert and is easy to install. Follow the directions below to install.

1. Lay the three pieces of brass trim on the floor in front of the insert. Arrange the brass trim so that it resembles the illustration below. The rounded edge of the trim that will be facing outwards when installed should be facing down.
2. Insert each "L" bracket leg into the groove in the 45° cut end of each side piece. Slide the other leg of each "L" bracket into the groove in each end of the top piece. Tighten the four set screws with a screwdriver into the "L" brackets, insuring that the 45° cuts are butted together to form a neat joint. Pick up the brass trim and slide it over the top panel until the trim is flush with the bottom edge of the top panel.

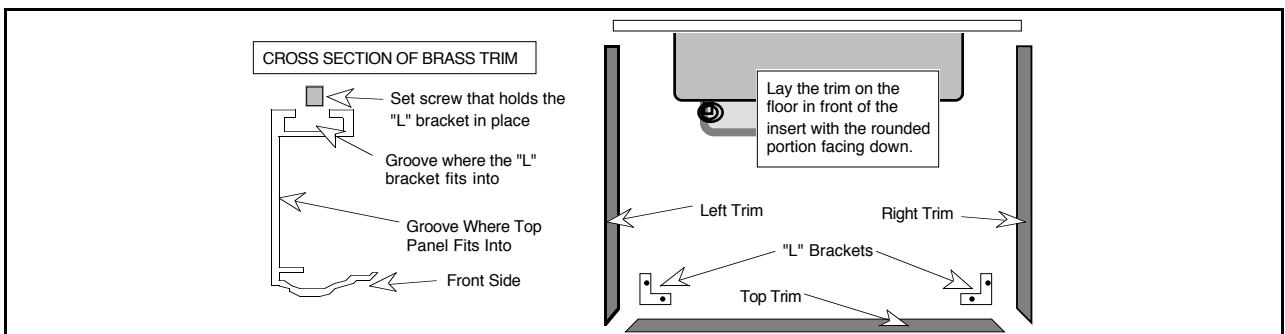

**SURROUND PANEL INSTALLATION (CONTINUED)**

3. Some kits include double-back tape. For those kits, follow the instructions below.

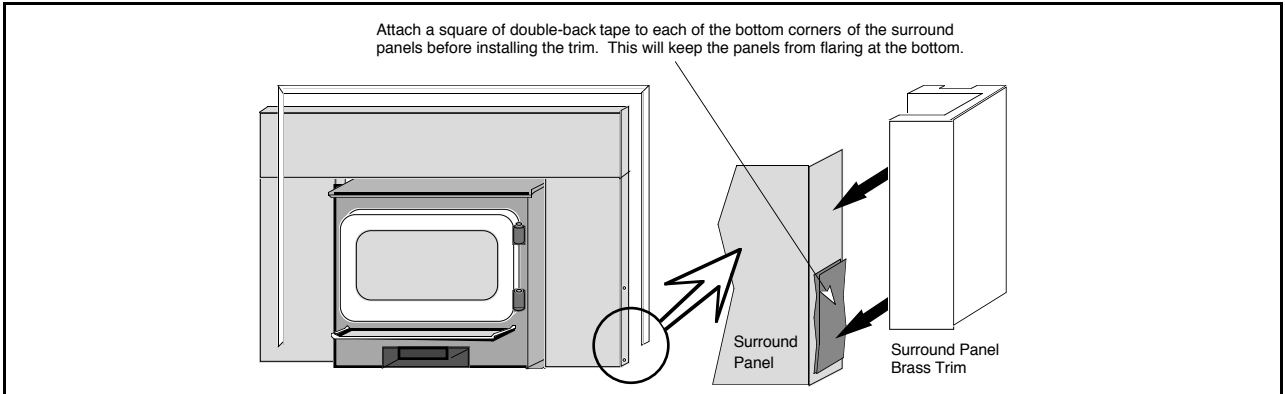

**FLUE ADAPTER INSTALLATION (PART NUMBER 98900120)**

The flue adapter has a built in flue collar with pre-drilled holes designed to make flue attachment easier. It may also be used to adjust the position of the flue exit, up to 2 1/2" forward or 1 5/8" back.

1. Determine the position of the flue adapter that best suits the installation. Mark the location of the four mounting holes on the top of the insert (NOTE: the position is variable – see the illustration below for details). Remove the flue adapter and drill four 5/32" holes into the top.
2. Adhere the self-adhesive gasket included with the flue adapter along the bottom perimeter of the adapter. Cut off any excess gasket.
3. Place the flue adapter in place. Use a 5/16" nutdriver to attach the four screws that secure it to the insert.

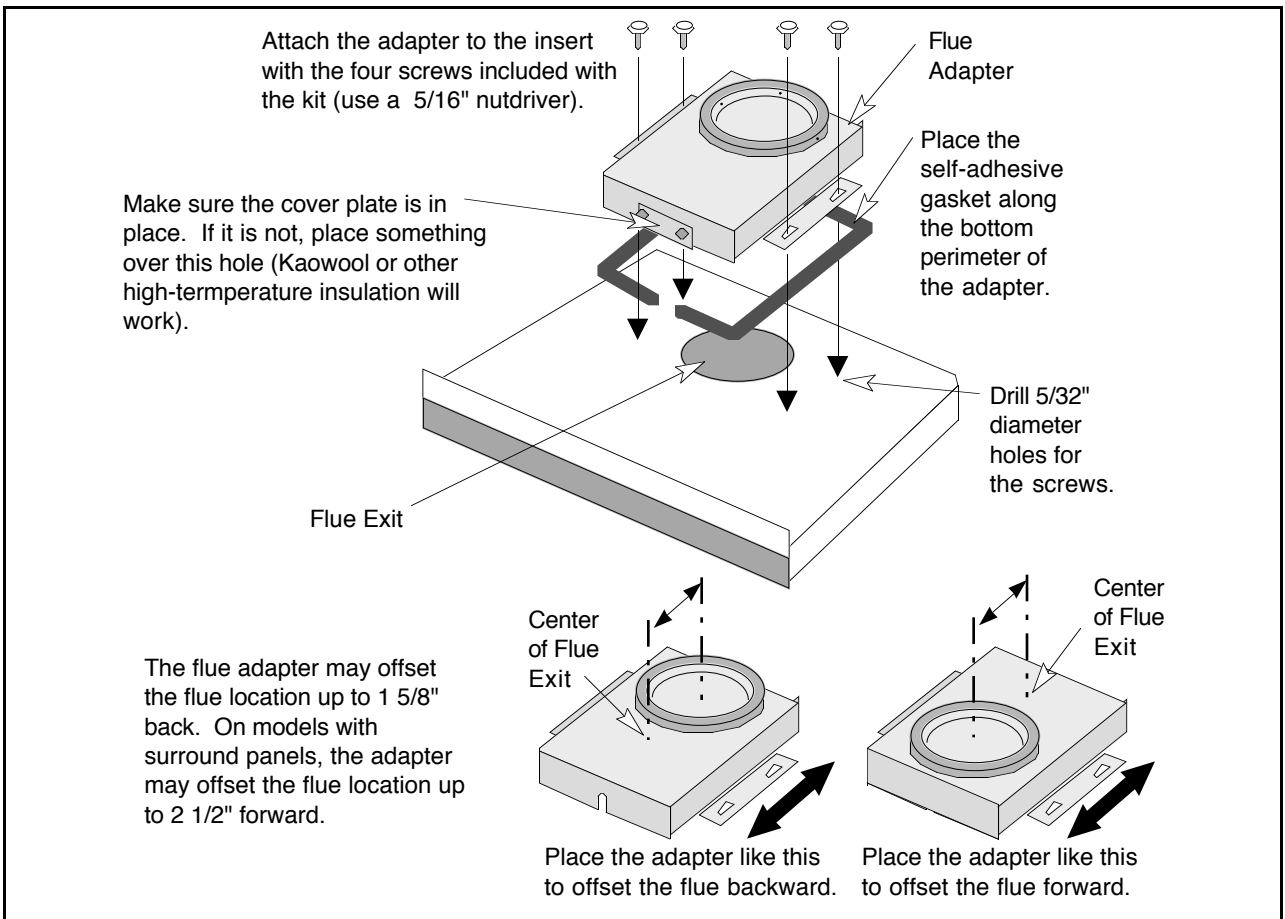

Adjusting the Heat Output.....	14	Heating Capacity.....	5
Air Control Settings.....	12	Insert Placement Requirements.....	7
Ash Removal.....	19	Insert Size Requirements.....	7
Baffle (removal and replacement).....	23	Insulation Installation (for panels).....	30
Block-Off Plate Installation.....	9	Leveling Bolt Installation.....	8
Blower (cleaning).....	22	Listing Information.....	28
Blower (installation).....	8	Location of Controls.....	12
Blower (operation).....	16	Log Length (Up to 24").....	5
Brass Cleaning.....	19	Maintenance Schedule.....	19
Brass Trim Installation (for panels).....	30	Masonry Fireplace Requirements.....	8
BTU Output.....	5	Offset (Flue Adapter).....	31
Bypass Control.....	13	Optional Equipment Requirements.....	6
Chimney Inspection (Creosote Inspection).....	19	Overnight Burn.....	15
Chimney Requirements (Masonry Fireplace Req.).....	8	Paint (touch-up).....	22
Clearances.....	7	Paint Curing.....	12
Creosote Inspection.....	19	Panels.....	29
Dimensions.....	5	Parts List.....	25
Direct Connection.....	10	Positive Connection.....	10
Door (Inspection).....	20	Reloading Your Appliance.....	14
Door Cam.....	20	Replacement Parts List.....	25
Door Gasket.....	21	Safety Label.....	28
Door Hinge (lubricating).....	21	Safety Precautions.....	2
Efficiency.....	5	Secondary Air Tube (replacement).....	25
Emissions.....	5	Secondary Air Tube (warranty - 5 yrs).....	27
EPA Emission.....	5	Specifications.....	5
Face Seal Connection.....	11	Starting the Fire.....	13
Fan Cleaning (Blower).....	22	Surround Panel Installation.....	29
Fan Installation (Blower).....	8	Table of Contents.....	4
Fan Operation (Blower).....	16	Troubleshooting Table.....	26
Firebox Size.....	5	Warranty.....	27
Firebrick (inspection and cleaning).....	22	Weight (Dimensions).....	5
Firebrick (removal and replacement).....	23	Wood Types.....	17
Fireplace Requirements.....	8		
Fireplace Sizing.....	7		
Floor Protection (see Hearth Requirements).....	7		
Flue Adapter Installation.....	31		
Flue Size (6").....	5		
Fuel to Use (cord wood only).....	17		
Glass (Inspection).....	20		
Glass Cleaning.....	19		
Glass or Glass Gasket.....	21		
Hearth Requirements.....	7		