



**Johnson Energy
Systems, Inc.**

Models

1750/7350

1700/9950

OWNERS MANUAL

SOLID FUEL OUTDOOR FURNACE

• **Assembly**

• **Installation**

• **Operation**

• **Repair Parts**



Warrnock Hersey



**IMPROPER INSTALLATION MAY VOID YOUR WARRANTY
SAVE THIS MANUAL FOR FUTURE REFERENCE**

CAUTION:

**Read All Instructions Carefully Before Starting The
Installation or Operating the Furnace**

- FOR PARALLEL INSTALLATION WITH EXISTING FORCED AIR, GAS OR OIL FIRED FURNACE
- FOR INSTALLATION AS A CENTRAL FURNACE

UNITED STATES STOVE COMPANY

111 Industrial Dr.

P.O. Box 151

South Pittsburg, TN 37380

85812 8/92

CONGRATULATIONS!

You've purchased one of America's Finest Wood and Coal Burning Furnaces. By heating with wood and coal you're helping CONSERVE AMERICA'S ENERGY!

Wood is our Renewable Energy Resource. Please do your part to preserve our wood supply. Plant at least one tree each year. Future generations will thank you.

NOTE:
YOUR UNIT MUST BE INSTALLED BY A QUALIFIED
FURNACE INSTALLER. IMPROPER INSTALLATION
COULD VOID YOUR WARRANTY.

NOTE: SEE PAGE 5, FIRST PARAGRAPH

Tools and Materials Needed

TOOLS

Pencil
6 Foot Folding Rule or Tape
Tin Snips
Drill, Hand, or Electric
Drill Bit (For Sheet Metal Screws 1/8" Diameter)
Screw Driver (Blade Type)
Gloves
Sabre Saw
5/16" Nut Driver or 5/16" Socket w/Ratchet

MATERIALS

1/2" Sheet Metal Screws
6" Inside Diameter Listed Double Wall Residential Type or
Building Heating Alliance Chimney
Electrical Wiring
6" Draft Regulator
3/8" Conduit & Conduit Connectors
Furnace Cement (Manufacturer Recommends:
Rutland Black - Code 78 or Equivalent)
Plenum and Duct Work as Required

CAUTION LABELS

Your furnace has the following labels. Read and obey all labels.

DANGER: RISK OF FIRE OR EXPLOSION

DO NOT burn garbage, gasoline, drain oil, or other flammable liquids.

WARNING: FIRE HAZARD

DO NOT operate with fire draft exceeding .06 inches w.c.

DO NOT operate with fuel loading or ash removal doors open.

DO NOT store fuels or other combustible material within the marked installation clearances.

**CAUTION
HOT SURFACES
Keep Children Away
Do Not Touch During Operation**

SAFETY NOTICE:

If this heater is not properly installed, a house fire may result.

For your safety, follow the installation directions. Contact local building or fire officials about restrictions and installation inspection requirements in your area.

RULES FOR SAFE INSTALLATION AND OPERATION

Read these rules and the instructions carefully. Failure to follow them will cause a hazard that could result in death, serious bodily injury, and/or property damage.

1. Check your local codes. The installation must comply with their rulings.
2. Do not connect this furnace to an aluminum Type B gas vent. This is not safe and is prohibited by the National Fire Protection Association Code. This furnace requires a double wall listed factory built chimney for residential type or building heating appliance chimney. Use a 6" diameter chimney that is high enough to give a good draft.
3. Inspect chimney before and frequently during the heating season for any deposit of creosote or soot which must be removed (see Chimney Maintenance, Page 13).
4. CAST IRON PARTS MUST BE "SEASONED" TO AVOID CRACKING. BUILD ONLY SMALL FIRES ON FIRST USE.
5. To prevent injury, do not allow anyone to use this furnace who is unfamiliar with the correct operation of the furnace.
6. For further information on using your furnace safely, obtain a copy of the National Fire Protection Association (NFPA) publication "Chimney's, Fireplaces and Solid Fuel Burning Appliances" NFPA 211. The address of the NFPA is Batterymarch Park, Quincy, MA 02269.
7. Keep the ashpit section free of excess ashes. Do not allow ashes to stack higher than the sides of the ash pan.
8. DISPOSAL OF ASHES -Place ashes in a metal container with a tight fitting lid. Keep the closed container on a noncombustible floor or on the ground, well away from all combustible materials. Keep the ashes in the closed container until all cinders have thoroughly cooled. The ashes may be buried in the ground or picked up by a refuse collector.
9. CAUTION-The special paints used on your furnace may give off some smoke while they are curing during first few fires. Build small fires at first. The metal used in construction of the furnace and duct work has a light coating of oil. This could give off smoke and/or odors from registers when furnace is used for the first time. This should disappear after a short period of time. Once this burn-off has occurred, it should not reoccur.
10. Keep the feed and ash doors closed at all times except while tending the furnace. (SEE OPERATING INSTRUCTIONS)
Your Furnace is designed to be installed in a parallel air flow arrangement with a gas or oil-fired forced air upflow-type central furnace, or it may be installed as a central furnace.

About Your Furnace

Your Hot Blast Furnace is designed to be a supplemental or central heating source for your home. This solid fuel furnace may be installed in conjunction with a properly operating central furnace that is listed or certified in accordance with nationally recognized safety standards and equipped with the required controls and other safety features and which has been installed in accordance with appropriate standards of National Fire Protection Association with installation clearances specified in the furnace name plate marking. The installation must be accomplished by a qualified agency (one who is engaged in, and is responsible for, or is thoroughly familiar with the installation and operation of the gas, oil, and solid fuel burning heating appliances, who is experienced in such work, familiar with all precautions required, and has complied with all the requirements of the authority having jurisdiction.) The installation shall be in strict accordance with the manufacturer's installation instructions furnished with the solid fuel furnace.

The Furnace is designed to operate in a parallel air flow arrangement with the central furnace or as a central furnace. The Furnace is designed to operate in either of the installations.

Model 1750/7350

Fig. 1

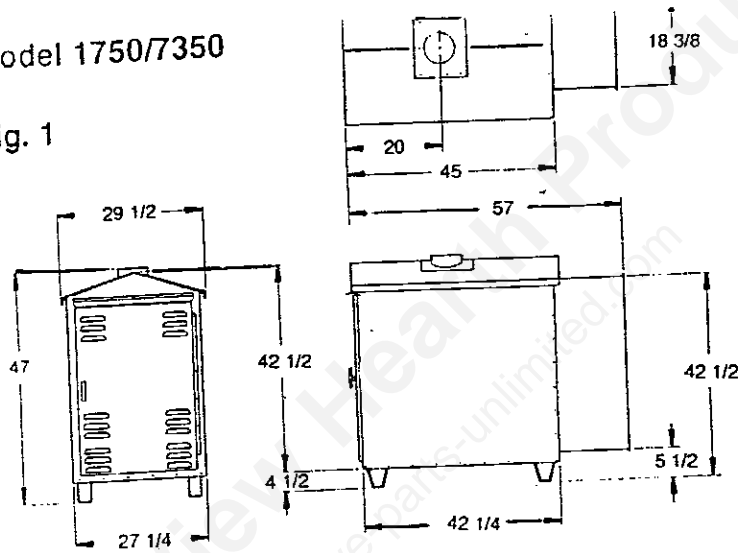

Model 1700/9950

Fig. 2

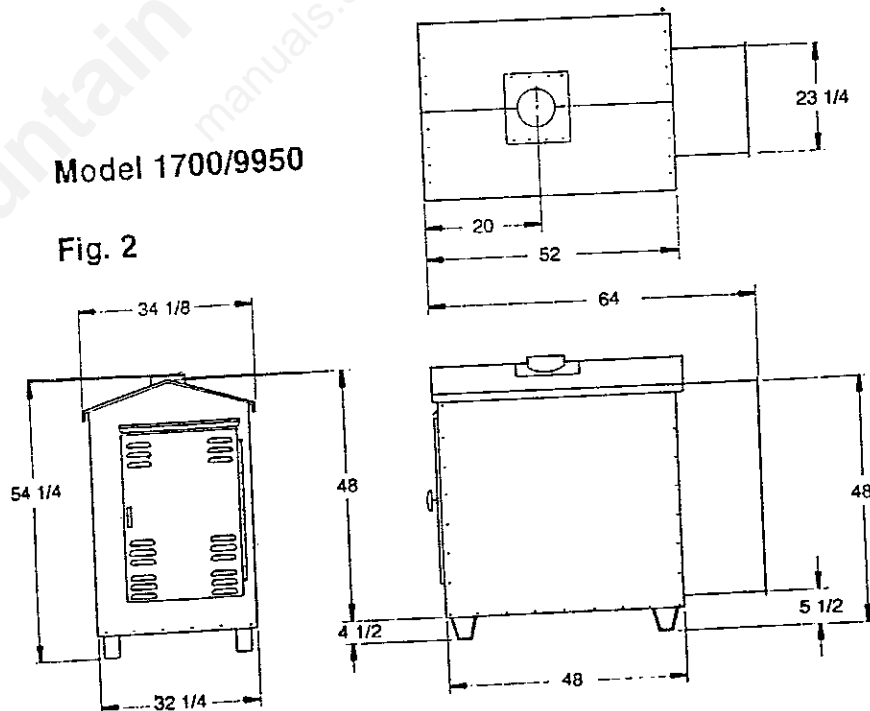

Locating the Furnace

1. Locate your furnace on the outside of the house, but in a centrally located area to facilitate and shorten piping and duct work.
2. Place the furnace on a level, non-combustible pad.
3. The unit will require installation with the following clearances:
Plenum to sidewall = 6 inches
Plenum to ceiling = 2 inches
4. The following illustrations represent recommended installations.

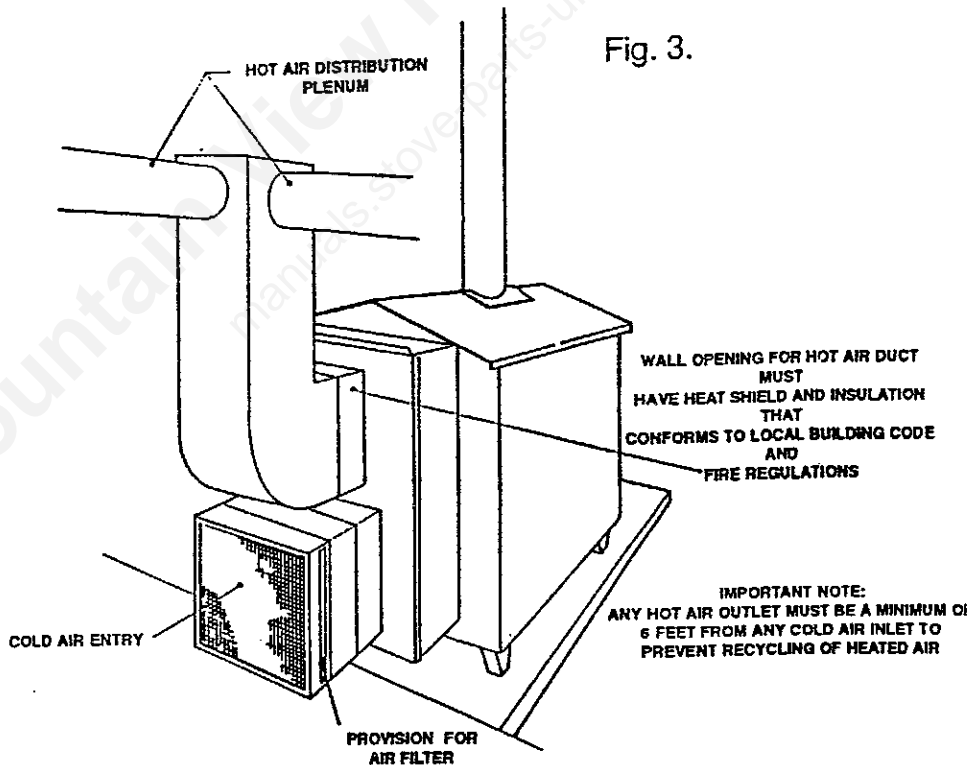

TYPICAL INSTALLATION THROUGH WALL OF BUILDING

FIG.4

TYPICAL ARRANGEMENT WHEN BOTH COLD AIR AND HOT AIR DUCTS MUST BE ON SAME LEVEL: AS UNDER CRAWL SPACE OR MOBILE HOME.

BOTH HOT AIR AND COLD AIR TRUNK LINES MUST BE INSTALLED (OUTSIDE ONLY) WITH A MINIMUM OF 6" INSULATION AND COVERED AND WEATHERPROOFED

HOT AIR OUTLET

COLD AIR INLET

DUCTS CAN BE SIDE BY SIDE WHEN PIPING RUNS ARE USED AND INLET AND OUTLETS ARE KEPT AT LEAST 6 FEET APART

Fig. 5

TYPICAL ARRANGEMENT WITH DUCTS SIDE-BY-SIDE AND PIPING RUNS

HEAT

RETURN AIR

chimney connection

LISTED FACTORY BUILT CHIMNEY

1. Carefully follow chimney manufactures instructions, use only a double wall listed residential type double wall building heating appliance chimney.
2. The top of the chimney must be at least 3 feet above the roof and be at least 2 feet higher than any point of the roof within 10 feet. (See Fig. 6)

Fig. 6

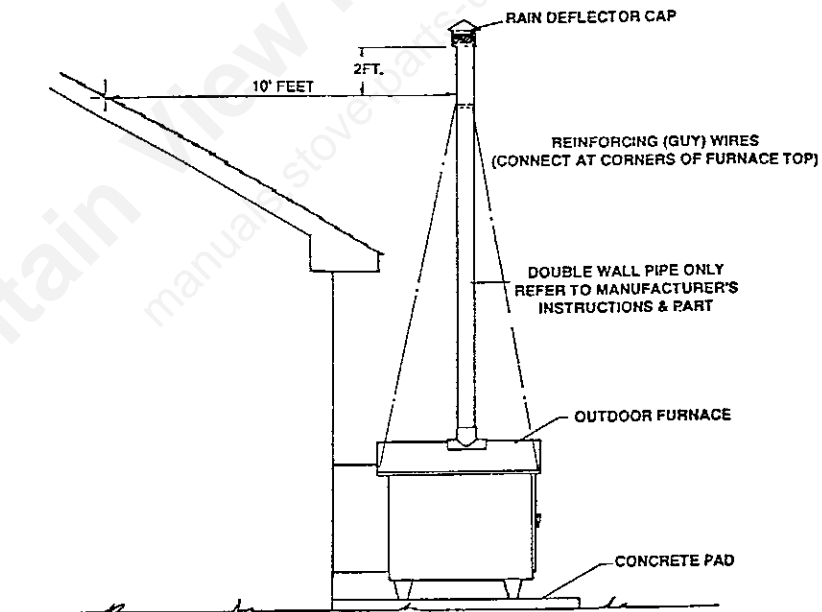

Wiring Diagram

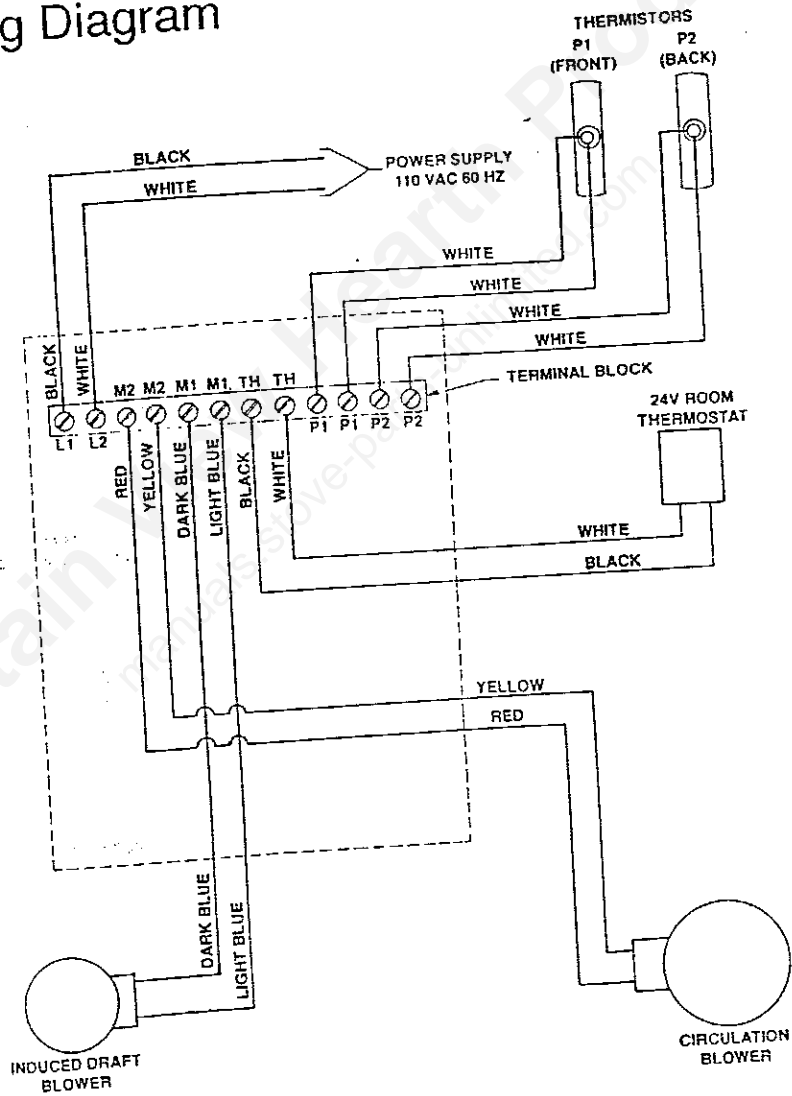

Fig. 7

Installation

1. This installation must be done by a qualified heating equipment installer.
2. The installation is to be done in compliance with National Fire Protection Association standards: No. 89M, 90B, 211, 70 (National Electric Code) and Uniform Mechanical Code 913, 6-4 in states where applicable.
3. The "Authority Having Jurisdiction" is to inspect all chimneys and installation for adequate venting and for compliance with standard and local codes and regulations regarding installation of wood burning appliances.
4. Locate the furnace as close as practical to the existing central hot air heating system, maintaining clearances as stated on page 7. Clearances from combustible materials must be complied with.
5. The installation must be made only on a non-combustible pad.
6. Install the smoke pipe connector to the chimney with double walled pipe (to be purchased separately), seal the smoke pipe in the connector with furnace cement. The chimney shall be securely supported, and joints fastened with sheet metal screws or rivets.
7. Connect electrical supply in the electrical box inside the cabinet door on the right. See Wiring Diagram on Page 10.
8. Remove the cover from the box and connect power supply wire at points designated on wiring diagram. The power supply wiring must be 90 degrees centigrade in a metal conduit and should be completed by a qualified installer complying with NFPA Standard No. 70 and local codes.

NOTE:

A separate breaker switch should be located in the power supply line between the main power source and the furnace, and should be turned off during the summer months to prevent sunlight from turning the forced draft blower on.

Operating Instructions

FUEL, (COAL)

Egg size (1 3/16" or larger) coal for residential furnaces, or any of the specially packaged fireplace coals can be used. Coal with a low ash content (2% to 6%) is recommended.

FUEL (WOOD)

Hardwood 18" to 24" should be split and airdried (seasoned) for 6 months.

LIGHTING THE FIRE

Note:

This furnace has no manual primary air for combustion. When starting a fire the feed door must be left open until it is determined that the fire is self sustaining. During this period the fire must be watched closely, and the feed door closed as soon as possible.

1. Open the feed door, place paper and kindling on the grate for starting the fire.
2. Light the fire (See Note Above) DO NOT leave the fire unattended until feed door is closed.
3. Add wood or about 15lbs. of coal after fire is burning briskly. Be careful not to smother the kindling fire.
4. Set room thermostat for desired temperature (the forced draft blower will not come on until the temperature has reached 95 degrees Fahrenheit in the air exchange area in the furnace walls.

service hints

Do not expect a furnace to draw. It is the chimney that creates the draft. Smoke spillage or excessive build-up of water or creosote in the chimney are warnings that the chimney is not functioning properly. Correct the problem before using furnace. Possible causes are:

1. If the chimney is operating too cool, water will condense in the chimney and run back into the furnace. Creosote formation will be rapid and may block the chimney. Operate the furnace at a high enough fire to keep the chimney warm preventing this condensation.
2. If the fire burns well but sometimes smoke or burns slowly, it may be caused by the chimney top being lower than another part of the house or a nearby tree. The wind blowing over a house or a tree, falls on top of the chimney like water over a dam, beating down the smoke. The top of the chimney should be at least 3 feet above the roof and be at least 2 feet higher than any point of the roof within 10 feet. (Fig 6).

A draft reading of .05 to .06 w.c. is suggested for proper burning of this unit when using wood or bituminous coal as fuel. When using anthracite coal, this draft reading is a minimum reading.

chimney maintenance

CREOSOTE AND SOOT - FORMATION AND NEED FOR REMOVAL

When wood is burned slowly, it produces tar and other organic vapors, which combine with expelled moisture to form creosote. The creosote vapors condense in the relatively cool chimney flue of a slow-burning fire. As a result, creosote residue accumulates on the flue lining. When ignited, this creosote makes an extremely hot fire.

When coal is burned, the products of combustion combine with moisture to form a soot residue which accumulates on the flue lining. When ignited, this soot makes an extremely hot fire.

The chimney should be inspected at least twice monthly during the heating season to determine if a creosote or soot build up has occurred.

If creosote or soot has accumulated, it should be removed to reduce the risk of a chimney fire.

Chimney fires burn very hot. If the chimney catches fire, immediately call the fire department, and turn off the electrical system serving the furnace. DO NOT open the feed or ash door during a chimney fire.

TROUBLESHOOTING CHART ELECTRONIC CONTROL

PROBLEM	PROBABLE CAUSE	CORRECTIVE ACTION
1. Combustion motor works, but the 3-speed motor is completely inoperative.	a. Motor not connected to the two "M2" terminals.	Connect motor to these terminals.
	b. Probe not connected to the two "P2" terminals	Connect probe to these terminals.
	c. No output voltage between the two "M2" terminals.	Check A/C voltage across these terminals
	d. Relay #3 defective	Replace relay #3
	e. Probe is open-circuited	Check probe resistance
	f. Q3 defective	Replace Q3
2. 3-speed blower blows cold air at low speed.	g. pot #3 defective	Check resistance of pot #3 Should vary from 0-0250kohms.
	a. Relay #1 defective	Replace relay #1
	b. Q1 defective	Replace Q1
	c. pot #1 defective	Check resistance of pot #1 to range from 0-250kohms.
	d. probe #2 defective	Check probe resistance
3. The motor operates at high and medium speeds, but not at low speeds.	e. probe #2 is exposed to sunlight	Shield the wood-burning furnace from sun-light
	a. Q2 defective	Replace Q2.
	b. Relay #2 defective	Replace relay #2.
	c. pot #2 defective	Check resistance of pot #2. It should vary from 0-0250kohms.

PROBLEM	PROBABLE CAUSE	CORRECTIVE ACTION
4. The motor operates at low and high speeds but not at medium speeds.	a. Q2 defective	Replace Q2.
	b. relay #2 defective	Replace relay #2.
	c. pot #2 defective	Check resistance of pot #2. It should vary from 0-250kohms.
5. The motor operates at low speeds but not at high speeds.	a. Q3 defective	Replace Q3.
	b. Relay #3 defective	Replace relay #3.
	c. pot #3 defective	Check resistance of pot #3. It should vary from 0-250kohms.
	d. probe 2 defective	Check resistance of probe 2 at 150 degrees F. Should be 10kohms. +or- 10%.
6. Motor stays on at high speeds at all temperatures.	a. Triac defective	Replace triac.
	b. Q3 defective	Replace Q3.
	c. relay #3 defective	Replace Relay #3.
	d. pot #3 defective	Check resistance of pot #3. It should vary from 0-250 kohms.
	e. probe 2 defective	Check resistance of probe at 77 degrees F. it should be 50kohms +or- 10%.
	f. probe 2 is exposed to solar heating	Shield the wood-burning furnace from sunlight.

PROBLEM	PROBABLE CAUSE	CORRECTIVE ACTION
7. The 3-speed motor operates, but the combustion motor does not go on at any temperature.	a. relays #4 or #5 defective	Replace defective relay.
	b. Q4 or Q5 defective	Replace defective transistor
	c. pot #4 or #5 defective	Check resistance of pots. Each one should range from 0-250kohms
	d. probe 1 defective	Check Probe resistance. Should be 50kohms +or- 10% at 77degrees F. Resistance should decrease with increasing temperature.
	e. no output voltage between the two "M1" terminals	Check AC voltage across the 2 "M" terminals. Should be 115 VAC.
	f. motor not connected to the 2 "M1" terminals	See if combustion motor is connected to these terminals.
	g. probe 1 is not connected to the 2 "P1" terminals.	See if a probe is connected to these terminals.
8. Combustion motor doesn't shut off at temperatures above 200 degrees F.	a. relay #5 defective	Replace relay #5
	b. Q5 defective	Replace Q5
	c. pot #5 defective	Check resistance of pot #5 it should vary from 0-250kohms.
	d. probe #1 defective	Check resistance of probe 1 at 200 degrees F. It should be less than 5kohms.
9. Combustion motor fails to shut off when thermostat opens.	a. Q4 defective	Replace Q4.
	b. relay #4 defective	Replace relay # 4
	c. pot #4 defective	Check resistance of pot #4. it should vary from 0-250kohms.

PROBLEM	PROBABLE CAUSE	CORRECTIVE ACTION
10. Both motors inoperative.	a. No line voltage connected to terminals L1 and L2	Check voltage between terminal L1 and L2.
	b. both (thermistors) probes are not properly connected at the terminal block	Check to make sure that one probe is connected to the terminals P1, O1, and the other to terminals P2, P2.
	c. transformer defective	Check voltage across secondary of transformer. It should be 25V???
	d. DC voltage across C1 below 25VDC	Check DC voltage across C1.
	e. bad solder connections at transformer or terminal block.	Check the solder at transformer, and terminal block.

repair parts: fire box

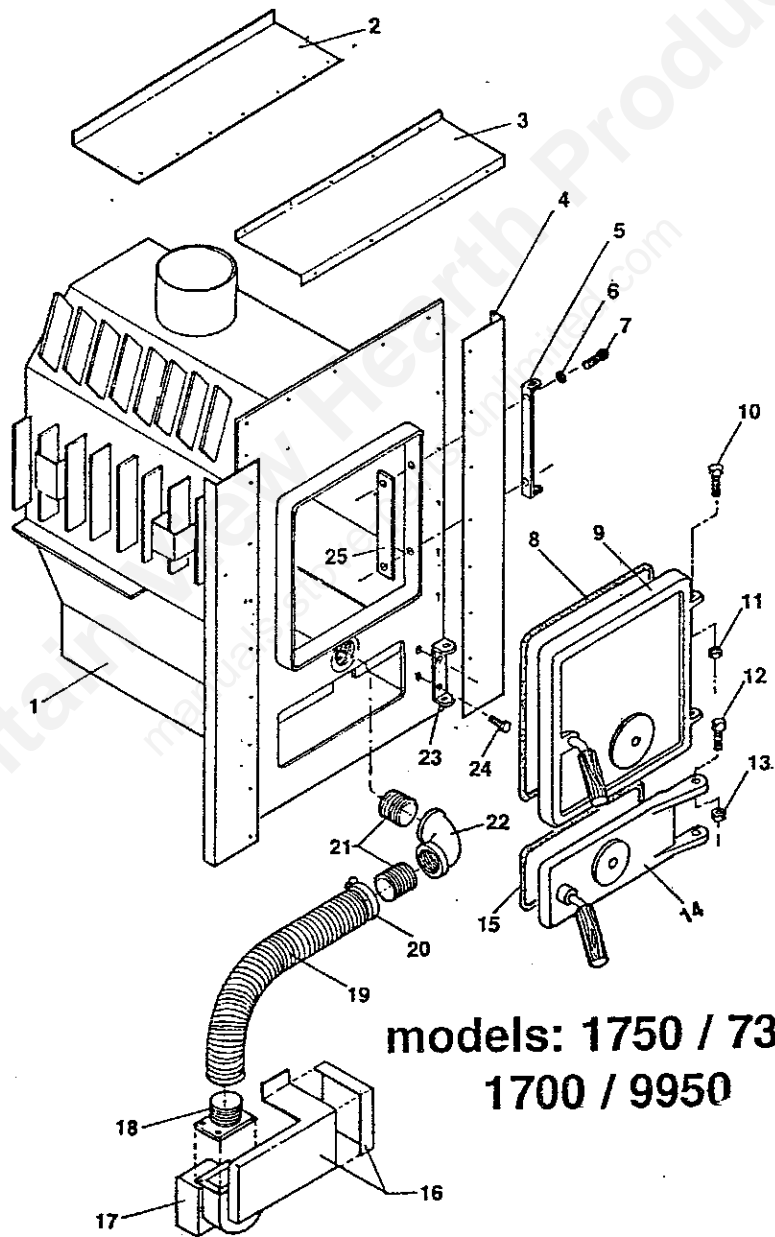

models: 1750 / 7350
1700 / 9950

repair parts: fire box

Key No.	Description	Qty.	1750/7350	1700/9950
1	Fire Box Assembly	1	68412	68414
2	Insulation Retainer Top Rear	1	23339	23346
3	Insulation Retainer Top Front	1	23340	23347
4	Side Insulation Shield	2	23341	23348
5	Feed Door Hinge	1	23342	23342
6	Flat Washer (1/4")	2	83268	83268
7	Bolt - 1/4-20x3/4"	2	83269	83269
8	Feed Door Gasket		88061	88061
9	Feed Door Assy.	1	68417	68417
10	Bolt - 1/4-20x1"	2	83270	83270
11	Locknut 1/4 - 20	2	83271	83271
12	Bolt 3/8-16x1 1/2"	2	83300	83300
13	Locknut 3/8-16	2	83301	83301
14	Ash Door Assy.	1	68419	68419
15	Ash Door Gasket		88062	88062
16	Draft Blower Shield	1	23343	23343
17	Draft Blower	1	80291	80291
18	Tube Connector Assy.	1	68422	68422
19	Flex Tubing	1	86453	86454
20	Tubing Clamp	1	83866	83866
21	Pipe Nipple	2	89504	89504
22	Pipe Elbow	1	89505	89505
23	Ash Door Hinge	1	23344	23344
24	Bolt 3/8-16x1"	2	83315	83315
25	Hinge Plate	1	23345	23345
•	Circulation Blower	1	89506	89506
•	Printed Circuit Board	1	80292	80292
•	Not Shown			

repair parts: cabinet
model 1750/7350
1700/9950

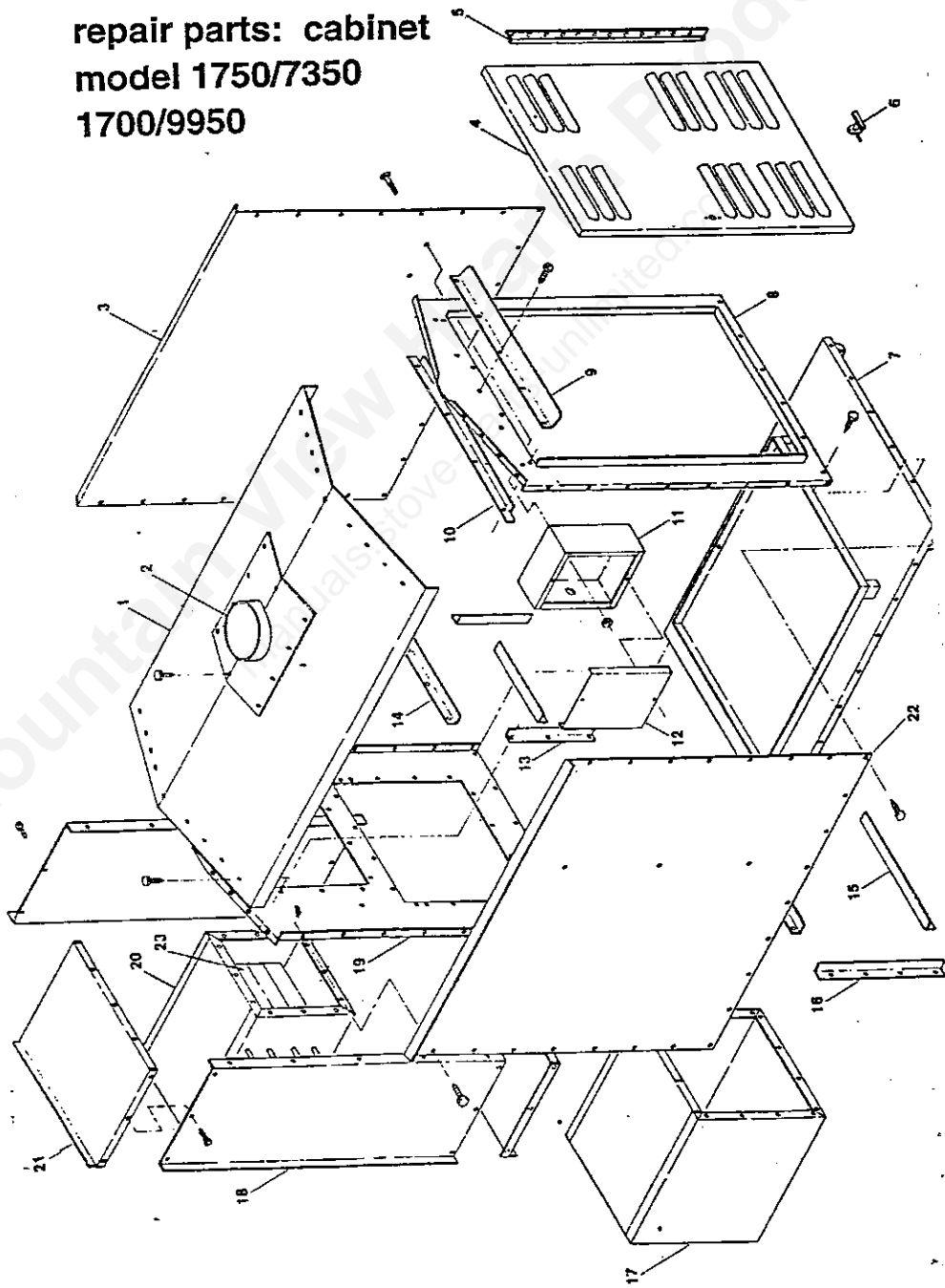

repair parts: cabinet

Key No.	Description	Qty.	1750/7350	1700/9950
1	Top Cover	1	23349	23350
2	Flue Outlet Assy.	1	68441	68443
3	Cabinet Side, Right	1	23352	23351
4	Cabinet Door	1	23353	23353
5	Door Hinge, Cabinet	1	89509	89509
6	Handle Assy.	1	89510	89510
7	Base Assy.	1	68433	68434
8	Front Panel, Cabinet	1	23354	23355
9	Deverter	1	23355	23356
10	Front Brace	1	23357	23357
11	Control Box	1	23358	23358
12	Control Box, Front	1	23359	23359
13	Side Brace, Top	2	23360	23361
14	Top-Bottom Brace, Upper	2	23363	23362
15	Side Brace, Bottom	2	23364	23365
16	Top-Bottom Brace, Bottom	2	23368	23367
17	Cold Air Duct Assy.	1	68440	68435
18	Side Duct Panel	2	23369	23370
19	Cabinet Panel Rear	1	23372	23371
20	Hot Air Duct	1	68447	68444
21	Top, Bottom Duct Panel	2	23373	23374
22	Cabinet, Side Left	1	23376	23375
23	Back Draft Damper	1	89507	89508

repair parts: grate

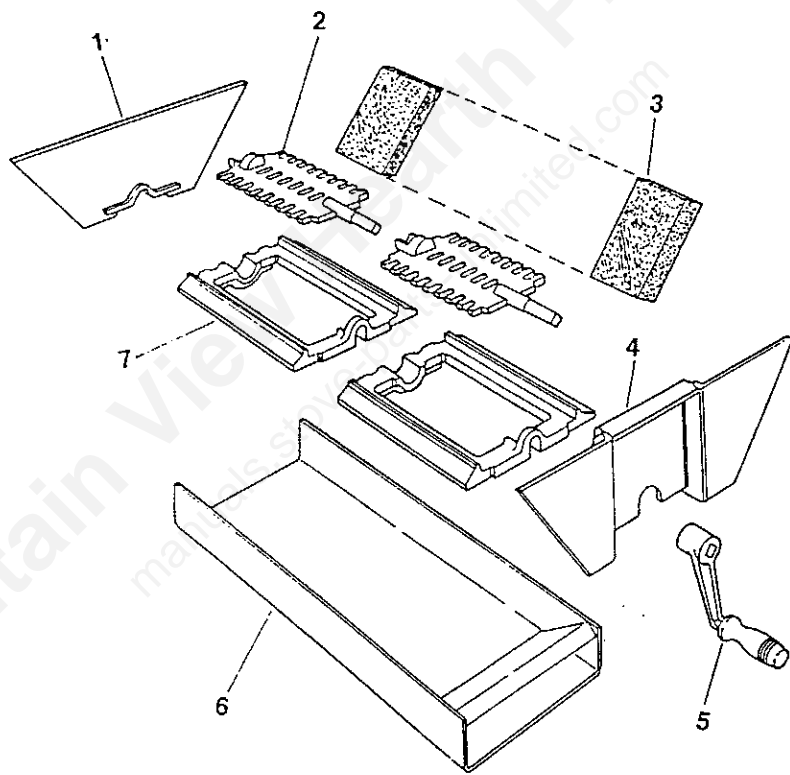

model 1750 / 7350
1700 / 9950

repair parts: grate

Key No.	Description	Qty.	1750/7350	1700/9950
1	Rear Baffle	1	40259	40259
2	Shaker Grate	1 or 2	40257	40257
3	Fire Brick	10 or 12	89066	89066
4	Front Baffle	1	40258	40258
5	Shaker Handle	1	40260	40260
6	Ash Pan Assy.	1	68580	68581
7	Grate Frame	1 or 2	40256	40256

owners manual

HOW TO ORDER REPAIR PARTS

THIS MANUAL WILL HELP YOU TO OBTAIN EFFICIENT, DEPENDABLE SERVICE FROM THE FURNACE, AND ENABLE YOU TO ORDER REPAIR PARTS CORRECTLY.

KEEP IN A SAFE PLACE FOR FUTURE REFERENCE.

WHEN WRITING, ALWAYS GIVE THE FULL MODEL NUMBER WHICH IS ON THE NAMEPLATE ATTACHED TO THE FURNACE.

WHEN ORDERING REPAIR PARTS OR OPTIONS, ALWAYS GIVE THE FOLLOWING INFORMATION AS SHOWN IN THIS LIST:

1. THE PART NUMBER
2. THE PART DESCRIPTION
3. THE MODEL NUMBER: 1750/7350 1700/9950
4. THE SERIAL NUMBER:

BEFORE INSTALLING YOUR HEATER, FILL IN THE SERIAL NUMBER OF YOUR FURNACE, WHICH IF ON THE NAMEPLATE, IN THE SPACE PROVIDED ABOVE.

UNITED STATES STOVE COMPANY
111 Industrial Drive
P.O. Box 151
South Pittsburg, TN 37380