



UNITED STATES STOVE COMPANY

Keeping America Warm Since 1869



MODEL: 1600 / 1800

THE WOOD AND COAL FURNACE

SAFETY NOTICE: IF THIS FURNACE IS NOT PROPERLY INSTALLED, A HOUSE FIRE MAY RESULT. FOR YOUR SAFETY, FOLLOW THE INSTALLATION DIRECTIONS. CONTACT LOCAL BUILDING OR FIRE OFFICIALS ABOUT RESTRICTIONS AND INSTALLATION REQUIREMENTS IN YOUR AREA.

Installation/Operator's Manual #851062E

TABLE OF CONTENTS

Introduction	1
Locating Your Furnace	1
Clearances	1
Chimney Requirements	1-2
Smoke Pipe Installation	2-3
Dampers on Stove Pipes	3
Installation Examples	3-4
Assembly Instructions	5-8
Electrical installation	9
Draft Wiring Diagram	10
Testing and Operating Procedures.....	11-12
Trouble Shooting and Problem Solving	13
Parts Lists	
Model 1600/1800	14-16
Motorized Natural Draft	17
Forced Air Draft.....	18
Optional Electronic Control System	
Installation	19
Parts List Model 1600	19
Wiring Diagrams.....	20-23
Installation of Optional Equipment	
Domestic Hot Water Coil	24
Back Draft Damper	25
Filter Boxes.....	26-27

INTRODUCTION

Thank you for your purchase of a U.S. Stove Woodburning furnace. Your decision to buy a Hotblast Furnace was undoubtedly reached after much careful thought and consideration. We are very proud you chose the U.S. Stove furnace and trust you will receive the comfort and economy that others realize when heating with a U.S. Stove product.

Your dealer is important in your experience with the Furnace not only in your purchase, but in his recommendations for professional installation in your home. The qualified professional installer (as recommended by your dealer) has been expertly trained in solid-fuel furnace installation to assure the safety and comfort for your family while saving you money. Trust your experienced installer. He is a specialist in his field.

IMPORTANT

Before installing and using your Hotblast Furnace, please read the following pages thoroughly and carefully. If you follow the instructions, your Hotblast furnace will give you safe and more dependable service in the years to come.

- ✍ First step; check your local codes. This installation must comply with their rulings.
- ✍ Do not install this furnace in a mobile home or trailer.
- ✓ Always have a smoke or ionization detector installed in your home.
- 4 To prevent injury or damage, do not allow anyone who is unfamiliar with the furnace to operate it.
- X Spend some time with your furnace to become well acquainted with different settings and how each will affect its burning patterns. It is impossible to state just how each setting will affect your furnace because of the variations in each installation.

DISCLAIMER NOTICE

The BTU ranges and heating capacity specifications are provided as a guide only and in no way guarantee the output or capacity of the units. The actual BTU output depends on the type of fuel being burned and its conditions, the thermostat setting, the draft adjustment and the chimney that the unit is hooked up to. The actual area that the unit will heat depends on factors such as the conditions of the building, heat loss, type of construction, amount of insulation, type of air movement, and the location of the unit.

chimney connector and extending at least 2" on either side of the chimney connector.

CLEARANCES

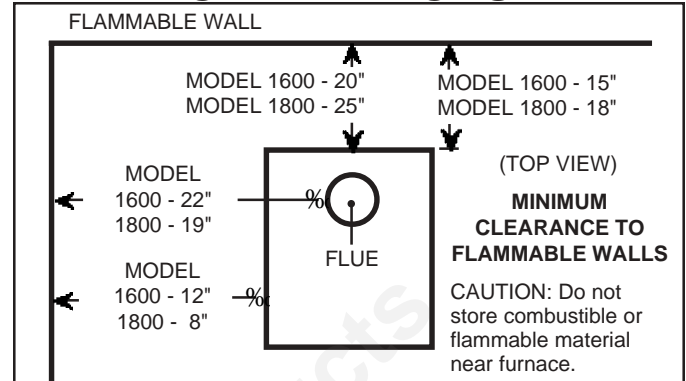

REDUCED CLEARANCES

NFPA guidelines and most codes permit reduced clearances to combustible walls and ceilings if adequate protection is added. A common mistake is to assume that sheet metal, masonry, or asbestos board placed directly against a wall protects it. Materials installed in this manner give very little protection. These materials are good heat conductors, so they will be almost as hot on their back side as they are on the exposed side. Therefore, the combustible wall behind is still a fire hazard.

A wall can be kept cool using these items but only if they're mounted and spaced out from the wall by an inch or two to allow free circulation of room air behind the protective panel. The protective panel should start within a few inches of floor level.

The three rules to follow when constructing wall protectors:

1. Non-combustibility of all materials including mounting or supporting.
2. A well ventilated air space between protector or wall.
3. Sufficient strength and rigidity so that the protector and

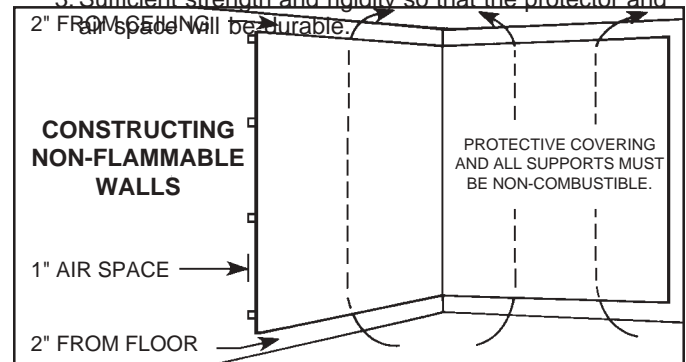

CHIMNEY REQUIREMENTS

A masonry or Class A All-Fuel Metal Insulated Chimney must be used in all airtight wood furnace installations. The minimum recommended flue size for the U.S. Stove Hotblast Furnace is 6" (inside diameter) for round flues, and 7" x 7" for square flues. When making new chimney installations,

LOCATING YOUR FURNACE

The furnace is to be installed maintaining clearances as shown in illustration.

Do not place the furnace directly on a combustible floor. If you're placing it on a combustible floor, an approved fire retardant material equivalent to 3/8" asbestos millboard should be placed under the furnace. The material must extend at least 16" in front of and 8" on either side of the fuel-loading and ash-removal doors, and underneath the

always follow the chimney manufacturers instructions.

NOTE: Type of chimney: Class A All-Fuel also referred to as Low-Heat appliance type chimney per Uniform Mechanical Code:

Chimney, low-heat appliance type is a factory built, masonry or metal chimney suitable for removing the products of combustion from fuel-burning low-heat appliances producing combustion gases not in excess of 1000°F under normal operating conditions but capable of producing combustion gases of 1400°F during intermittent

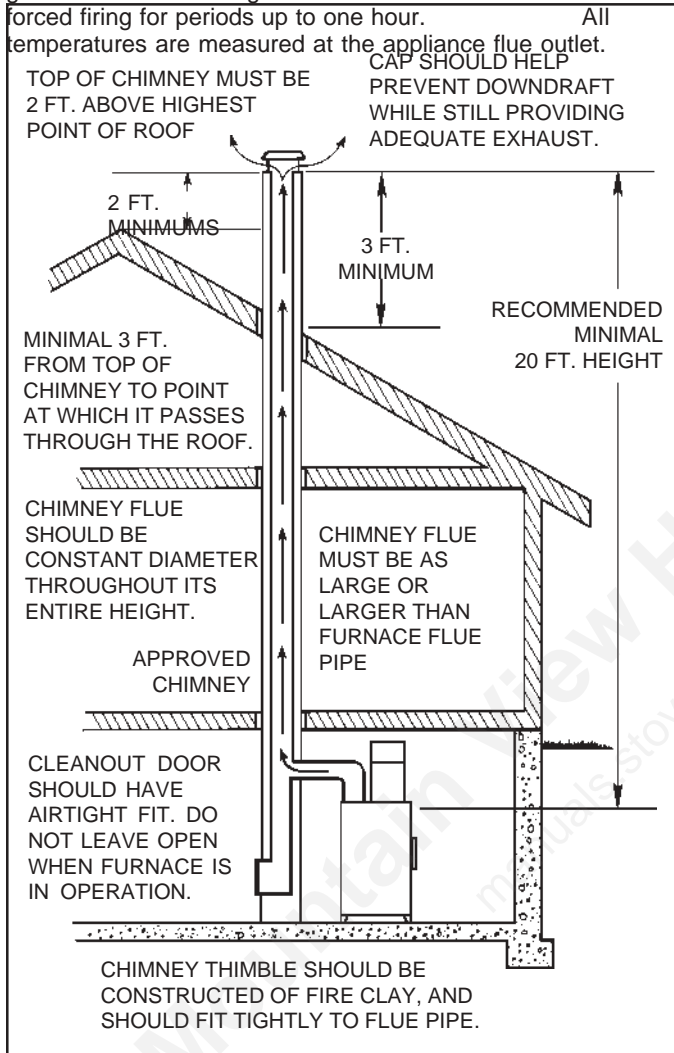

highest point of the house, or 2' above the point at which the chimney is 10' from the roof.

7. The chimney should be relatively straight and vertical.
8. The portion of an all-fuel metal chimney that extends above the roof should be well secured.
9. A masonry chimney should be built on footings and not attached to the house.
10. A rain cap, complete with an animal or bird screen, should be installed on top of the chimney.

CREOSOTE — FORMATION AND NEED FOR REMOVAL

When wood is burned slowly, it produces tar and other organic vapors, which combine with expelled moisture to form creosote. The creosote vapors condense in the relatively cool chimney flue of a slow-burning fire. As a result, creosote residue accumulates on the flue lining. When ignited, this creosote makes an extremely hot fire.

The chimney connector and chimney should be inspected at least twice monthly during the heating season to determine if a creosote build-up has occurred. If creosote has accumulated, it should be removed to reduce the risk of a chimney fire.

SMOKE PIPE INSTALLATION

Clearances to combustible materials (i.e. paneling, ceiling tile, sheet rock, plaster, draperies, casements or wood trim, etc.) will vary with the type of flue connection used. Be sure to maintain the specified clearances for your type of installation.

TYPE OF FLUE CONNECTION	REQUIRED CLEARANCE
24 Gauge or Heavier Single Wall Stainless Steel	18"

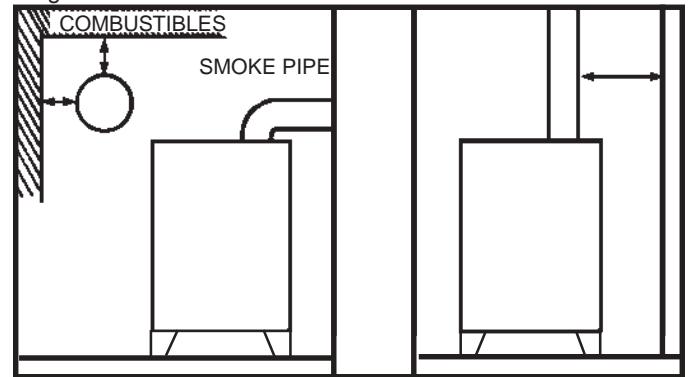

or Black Pipe
 Double Wall Stainless Steel 6" Model 1600
 8" Model 1800

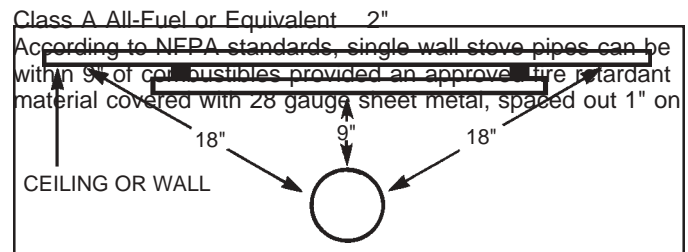

non-combustible spacers, is utilized. See illustration.

1. The wood furnace should be the only heating appliance using a chimney flue. One furnace per flue.
2. A masonry chimney should have a tile or stainless steel liner.
3. The masonry chimney should not have any missing mortar or loose bricks.
4. There should be no mortar or parts of the chimney blocking the chimney flue.
5. There should be a two inch clearance between any chimney (masonry or metal) and combustibles (such as the house).
6. The chimney should extend at least 2' above the

When using a Class A or double wall flue pipe connection, follow the manufacturer's instructions.

When constructing a single wall smoke pipe, the following guidelines must be observed.

1. The smoke pipe should be 24 gauge or heavier stainless steel or black pipe.
2. Secure all joints with three #8 screws.
3. If the smoke pipe must pass through a wall, an approved thimble, at least three times the diameter of the smoke pipe must be used. (i.e. a 6" diameter smoke pipe needs an 18" thimble).
4. The smoke pipe should not be used as a chimney.

IMPORTANT INFORMATION FOR ALL SMOKE PIPES

The smoke pipe must be constructed and installed so that it maintains clearances, keeps condensation and creosote within the pipe, and is capable of withstanding a two to three thousand degree chimney fire.

1. The smoke pipe should slant down toward the furnace a minimum of 1/4" to the foot. At no time should the pipe turn downward toward the chimney or run horizontal.
2. There should be no more than two 90 degree elbows.
3. The smoke pipe should never be longer than six feet. If it is absolutely necessary to make a run of more than six feet (not recommended) use extra support brackets every 3 feet.
4. The smoke pipe should never be reduced to a smaller size than flue opening on the furnace.
5. The smoke pipe should not block the flue of the chimney or extend into it in any way.
6. A good airtight thimble should be used to hold the smoke pipe in the chimney. It should be constructed so the smoke pipe can be removed for cleaning.
7. The smoke pipe should not leave the heated portion of the building to reach the chimney.
8. The smoke pipe should not pass from one story to the next before entering the chimney, nor should it pass through any closed or enclosed space.
9. Heat reclaimers should not be installed or used in the smoke pipe.
10. The smoke pipe should not be located near or in a walk way or well traveled area.

11. All male ends of smoke pipe should run or point towards the furnace.

DAMPERS ON STOVE PIPES

When burning coal, we recommend a Barometric Draft Damper be installed at a safe convenient place between chimney and your furnace.

When you have installed the smoke pipe connecting your furnace to the chimney, tap the pipe hard with your fingernail. Remember the sound it makes - it will be a "ting" echoing inside the stove pipe. If later you tap and hear a muffled thud, you are building up soot in the pipe and should clean it. This pipe should be cleaned at least once or twice during the

heating season.

DO NOT CONNECT TWO HEATERS TO THE SAME CHIMNEY FLUE. The National Fire Prevention Association recommends that woodburning appliances vent into a separate chimney from gas or oil furnaces. If such an installation is contemplated, first check with a local building inspector to find out if a separate flue for a woodburner is required.

If codes allow, use extreme care in making such installations. Be sure that one pipe is higher than the other so that the two openings will not be opposite each other. Also, when connecting two heaters into the same chimney flue, the flue size should be large enough to handle both heaters. Very few codes and standards allow same flue connection. Such installations can cause severe problems. Gas hoods and barometric dampers allow excess air into the chimney causing cooling of the flue gases and a greater creosote build-up potential. If the same flue connections are used, chimneys must be inspected more frequently and the chimney should be cleaned any time the creosote deposits exceed 1/4" thickness. A creosote fire in such a chimney can burn out of control because of the air leak through the barometric damper or gas hood. Keeping the chimney clean and burning well-seasoned wood is absolutely necessary. This type of installation does require more frequent inspection and maintenance.

HEATED AIR DISCHARGE

The Hotblast furnace is designed for use as a supplemental heating source. When used as a supplementary furnace, the 1600/1800 is connected in conjunction with an oil, gas, or electric furnace to the existing duct work which distributes the heated air into several rooms and/or areas.

When used as a space heater, heated air from the 1600/1800 furnace is expelled directly into the room in which the furnace is located. In installations of this type, the flow of heated air from the furnace must not be blocked. It is recommended that an elbow be attached to the heated air discharge to divert the heated air away from combustibles. All other criteria for installation remains unchanged.

CONNECTING HOT AIR DUCT TO FURNACE

We strongly recommend that the hot air duct work be installed by a home heating specialist. If doing the installation yourself, before you decide which installation will best suit your needs, consult a qualified heating technician and follow his recommendations as to the safest and most efficient method of installation.

The following illustrations are the only acceptable configurations when installed with existing oil or gas furnaces.

INSTALLATION EXAMPLES

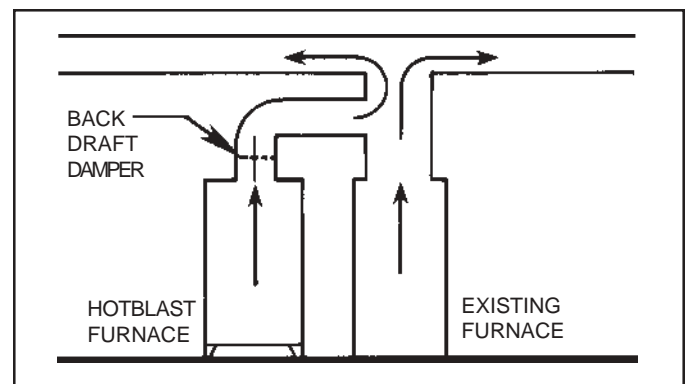

INSTALLATION NO.1

With this installation, a back draft damper is inserted into the heat run before the plenum of the existing furnace to prevent air from the existing furnace to blow back into the furnace when it is not in use. When a back draft damper is employed, it should be located as close to the existing furnace plenum as practical.

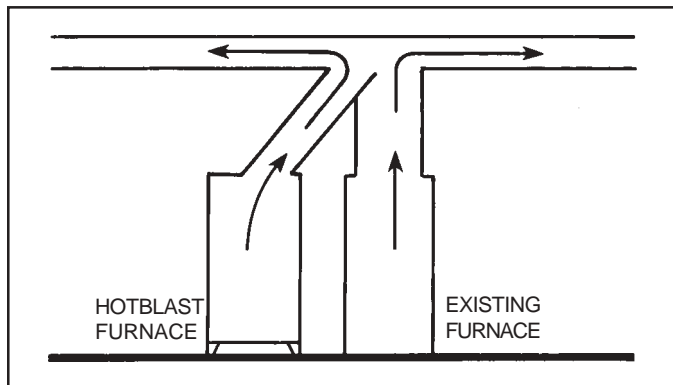

INSTALLATION NO. 2

Extending the hot air duct from the furnace into the existing plenum will help direct the flow of air from the 1600/1800 as well as the flow in the existing furnace. Ducting entering the

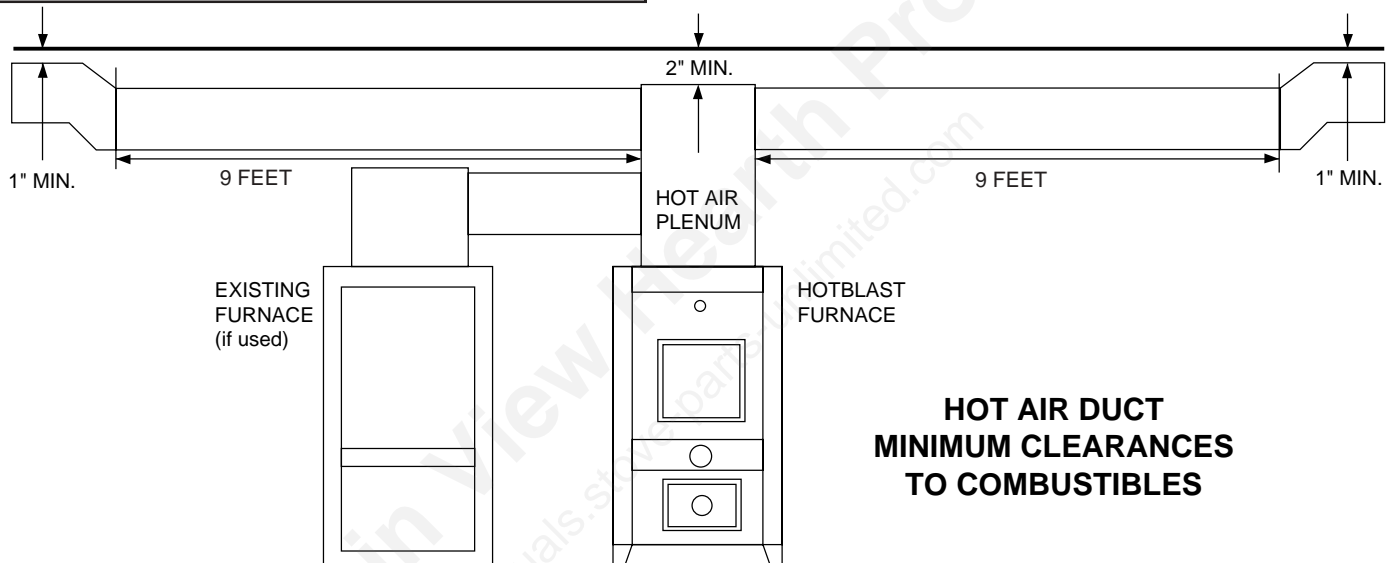
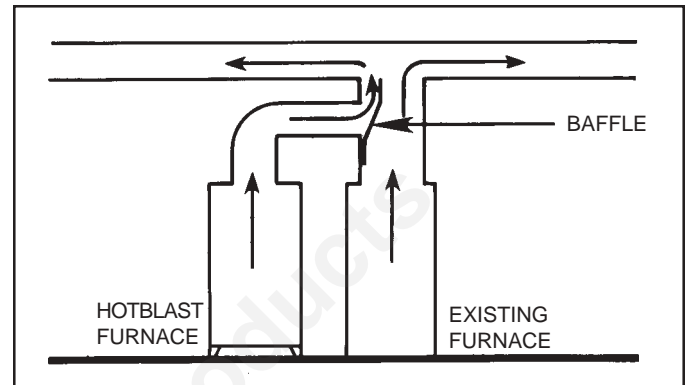

existing plenum at an angle (approximately 45 degrees) will facilitate air flow from the furnace while diverting air from the existing furnace.

incorporated into the system. Return air can be provided by installing a separate duct system or by tying into the cold air return of an existing gas or oil furnace. The cold air return duct can be connected to the furnace with either a factory manufactured U.S. Stove filter box or an equivalent fabricated from sheet metal (See pages 21-23).

INCORRECT INSTALLATION

For cold air return, the following minimum size should be maintained to insure proper furnace performance.

NO RETURN AIR PROVIDED
Model 1600 --- 16" x 20" or equivalent
Model 1800 --- 16" x 20" or equivalent

Failure to provide return air duct of the specified size voids the furnace warranty.

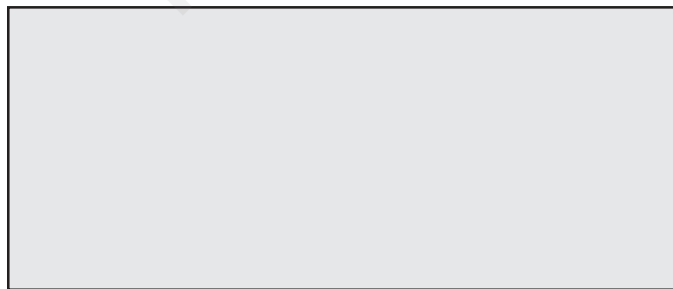
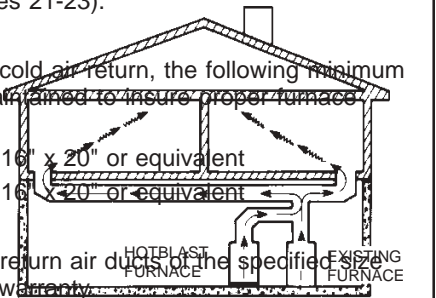

INSTALLATION NO. 3

The baffle on this system should be made the full width of the furnace plenum in order to properly direct the air into the distribution ducts.

RETURN AIR IS VERY IMPORTANT

When installing a Hotblast Furnace, return air must be

A filter should be installed in the cold air return. Furnace filters should be checked and cleaned or replaced regularly.

If return air is not provided, the warm air distributed into your home will be restricted and the efficiency of the furnace decreased. Without a return air system, warm air will be drawn into your basement, unnecessarily heating unused areas of the home. In extreme cases, if your basement or utility room is fairly air tight, the large blower on the 1600/1800 could depressurize the room and pull toxic flue gases from the

furnace, a gas water heater, or gas furnace. The fumes could then be distributed throughout the house.

ASSEMBLY INSTRUCTIONS

- Three 1/2" Lock Nuts
- One 1/2" x 2 1/2" Carriage Bolt
- Six 1/4" x 3/4" Hex Bolts
- Smoke Door
- Two 1/4" x 1-1/4" Carriage Bolts

COMBUSTION AIR

to make sure there is no kinking or damage, and that all necessary parts are located in the firebox. See Parts List for complete combustion that takes place when a furnace is "air starved" causes carbon monoxide (CO) to be formed in quantities that can be dangerous inside a well-sealed home during a source of combustion air from outside prevents this "air starvation" of the furnace.

Your furnace is shipped from the factory in four (4) packages. 1) the furnace, 2) the blower, 3) draft kit, 4) fan limit kit or electronic circuit board. Before assembling the furnace, check carefully. He will take the necessary steps to correct the problem.

Parts List

All models include the following:

- Two Door Handles
- One Fuel Door Latch
- One Ash Door Latch
- One Shake-Grate Handle
- Two 1/2" Washers
- Four 1/4" Hex Bolts
- Four Lock Washers
- Spin Draft
- Five 1/4" Lock Nuts
- One Pivot Bracket
- Four Brass Coil Knobs
- One 1/4" x 1" Hex Bolt

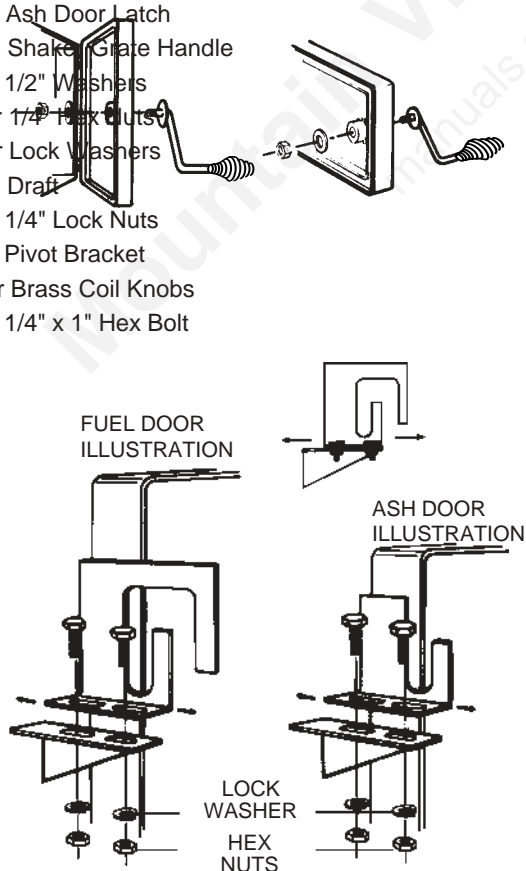

MODEL 1600 - (6) BRICKS ON EACH SIDE

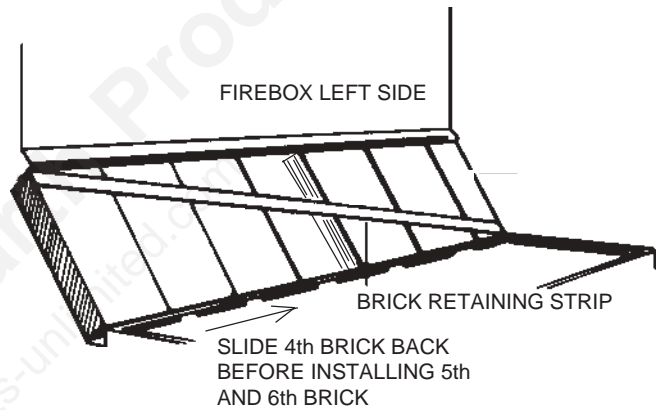

MODEL 1800 - (8) BRICKS ON EACH SIDE

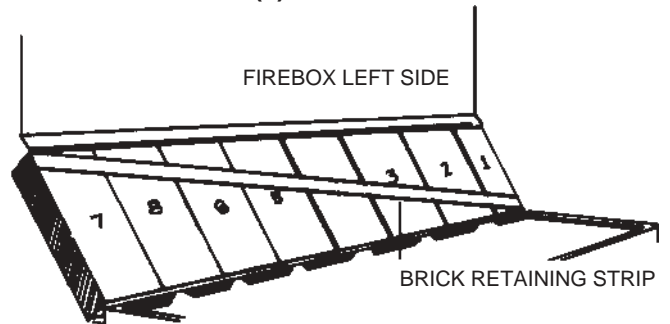

- Two Smoke Door Clips
- Rod Extension
- Manual

DOOR HANDLE INSTALLATION

Insert door handle into door. From rear side of door place 1/2" washer over threaded part of door handle. Then attach 1/2" lock nut, being careful not to over tighten. Handle should turn freely.

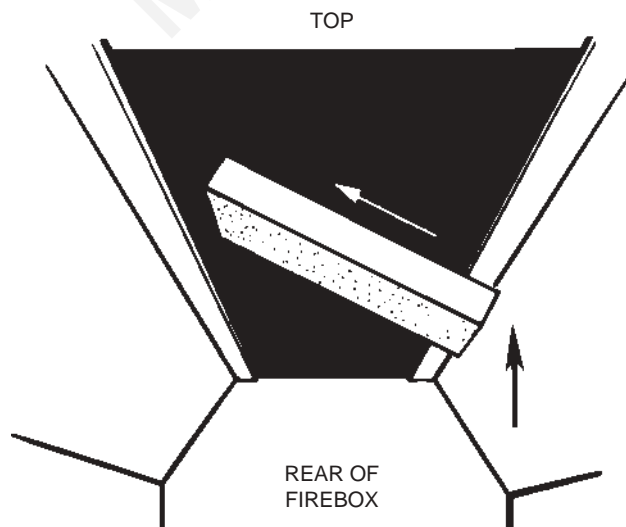
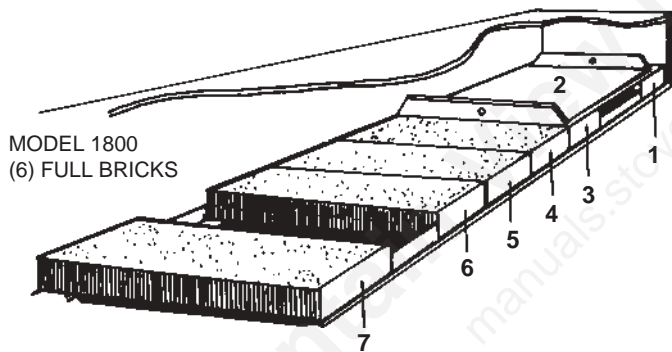
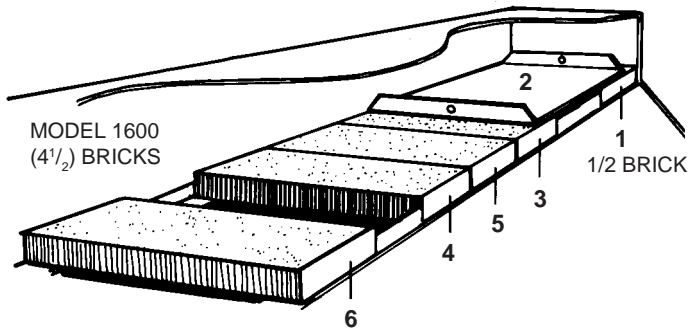

FUEL & ASH DOOR LATCH INSTALLATION

With two 1/4" x 3/4" hex bolts, attach the door latch to the

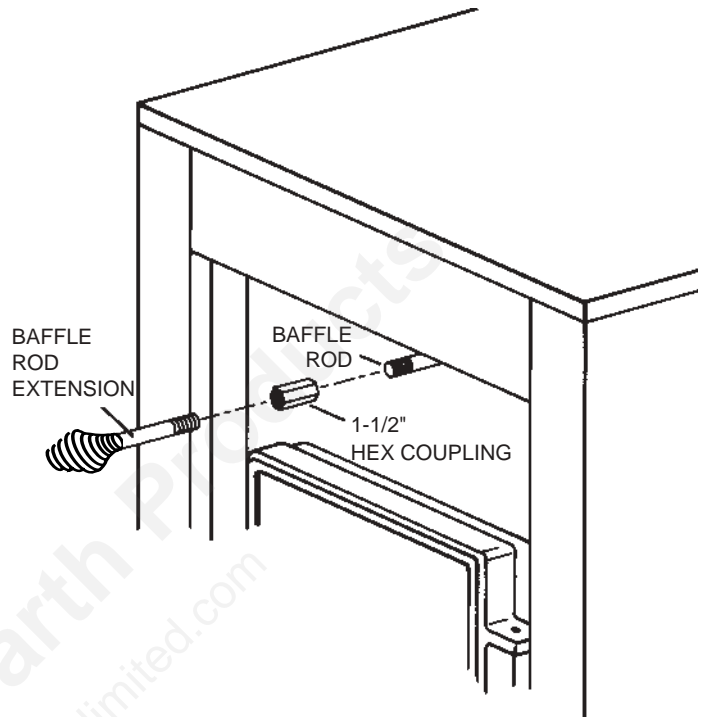

THE MODELS 1600 AND 1800 HAVE BEEN EQUIPPED WITH DIFFERENT PLENUM OPENINGS, THEY ARE AS FOLLOWS:

door latch mounting bracket on the left side of door frame as illustrated. Adjust latch until door closes securely.

MODEL 1800

18"x18" Square Plenum Opening

BRICK INSTALLATION (PRE-INSTALLED AT FACTORY)

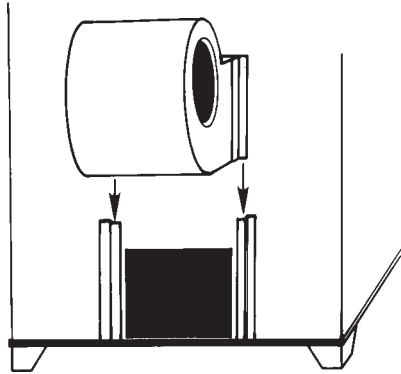

NOTE: Prior to operation, be sure to remove brick retaining strips.

FIREBOX:

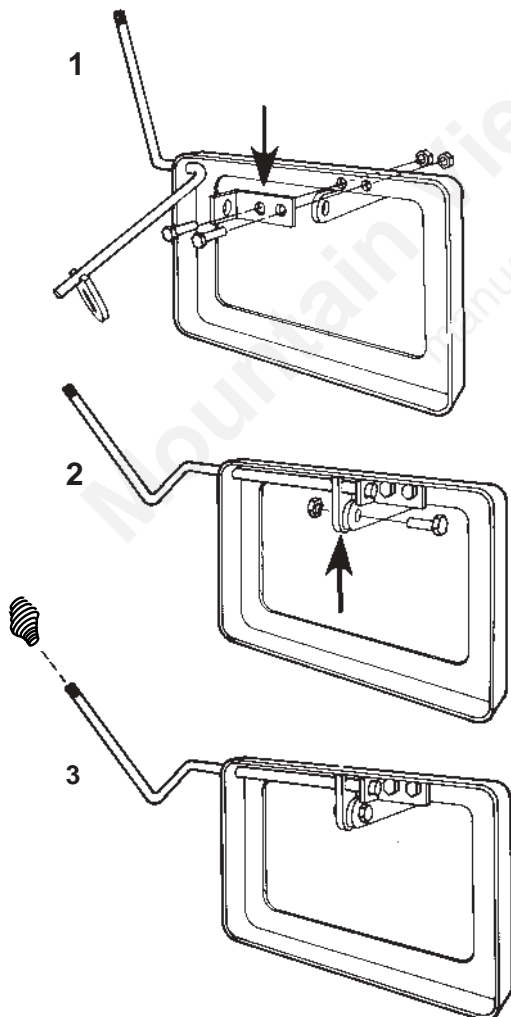

The firebrick must be inserted on each side resting on the

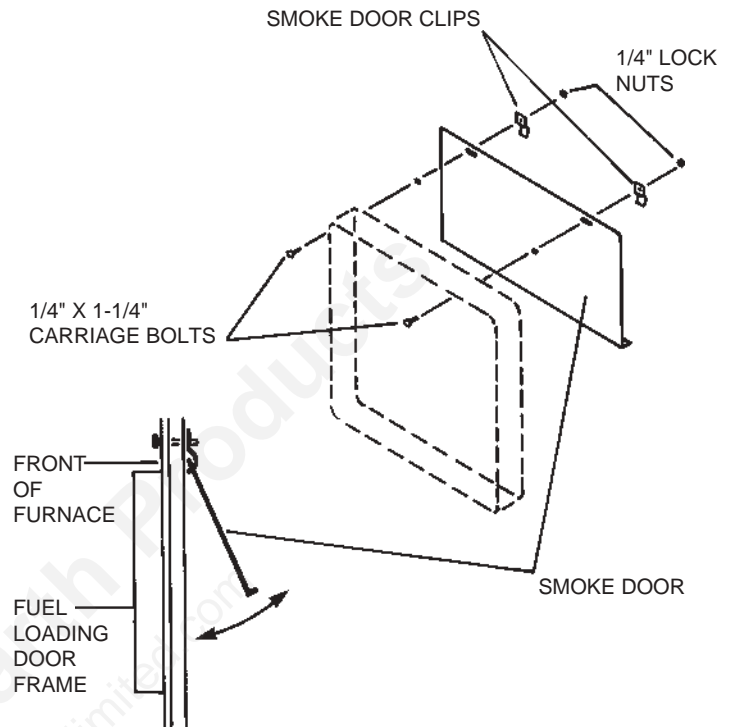

grate frame. First, place cut brick in each back corner. Place remaining brick in place.

SMOKE CHAMBER:

1. Place #1 firebrick in the back of smoke chamber.
2. Slide baffle plate into smoke chamber, flat side down.
3. Place remaining firebrick in smoke chamber as

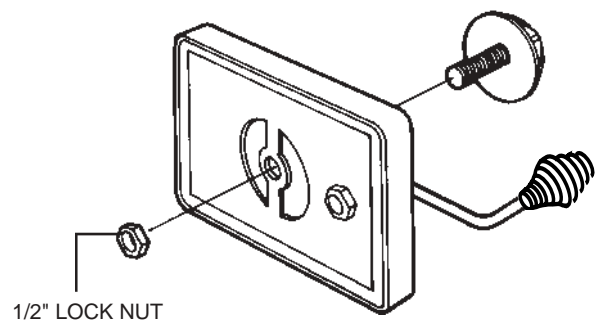
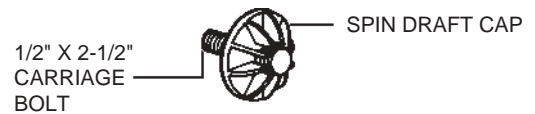

MOUNTING PROCEDURE FOR DRAFTS

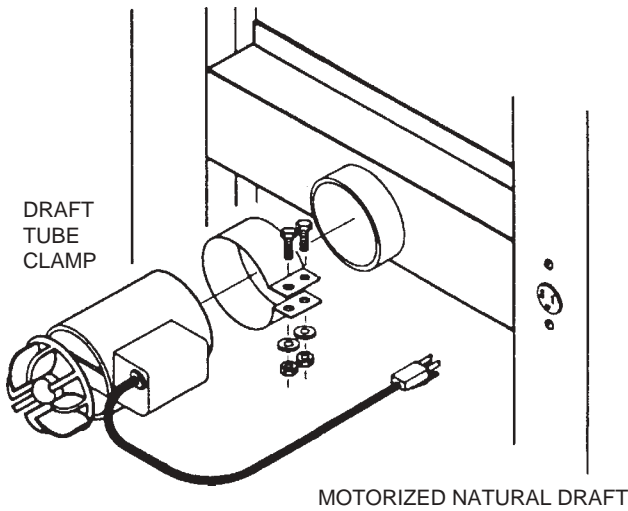

OPTIONAL MOTORIZED NATURAL DRAFT

Models 1600 / 1800

1. Using (2) 1/4" x 1" bolts, lock washers and nuts, attach draft to furnace with draft tube clamp.
2. Plug draft power cord into receptacle on front of furnace.

MODEL 1600/1800 -
KIT #C60357M

FORCED AIR DRAFT (SHIPPED WITH UNIT)

1. Using (2) 1/4" x 1" bolt, lock washer and nut, attach draft adapter bracket to furnace draft tube.

MODEL 1600/1800
KIT #69189

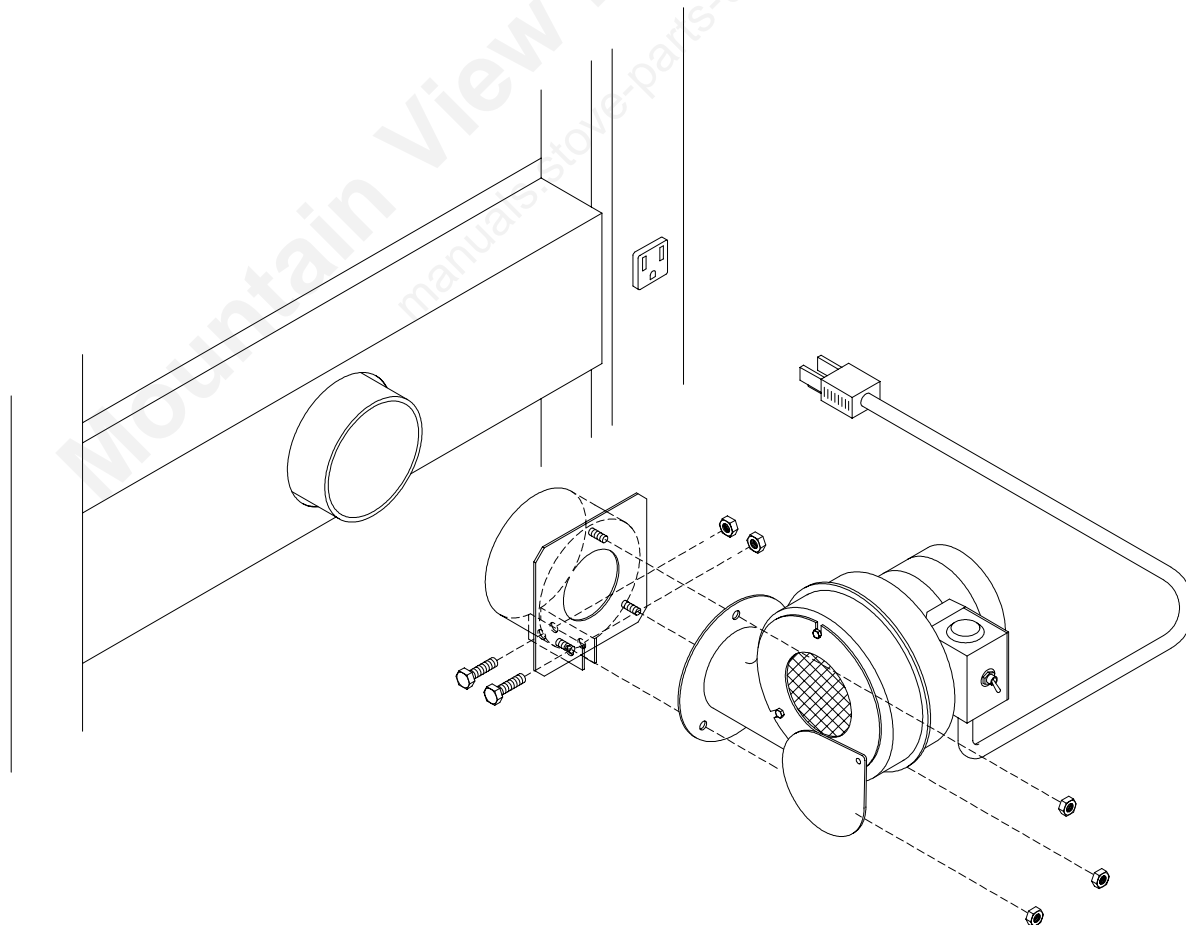

ELECTRICAL INSTALLATION

Predrilled holes are provided on the back of the furnace for mounting the fan center electrical box. Mounting holes and knockouts are also provided to accommodate mounting the high limit control in either the upper left or upper right corner.

The flexible conduit connecting the high limit control to the fan center electrical box has been sized longer for the model 1800. This conduit may be cut shorter to provide a cleaner installation on model 1600.

ALL WIRING MUST BE DONE BY A QUALIFIED ELECTRICIAN

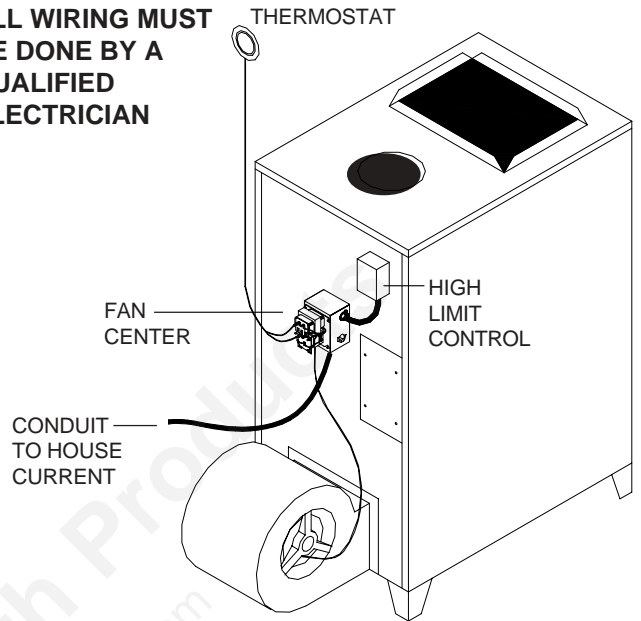

REAR VIEW

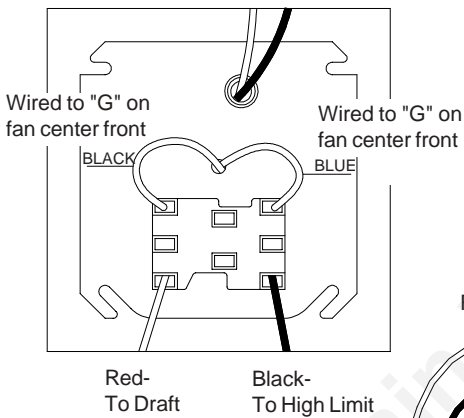

DRAFT WIRING DIAGRAM

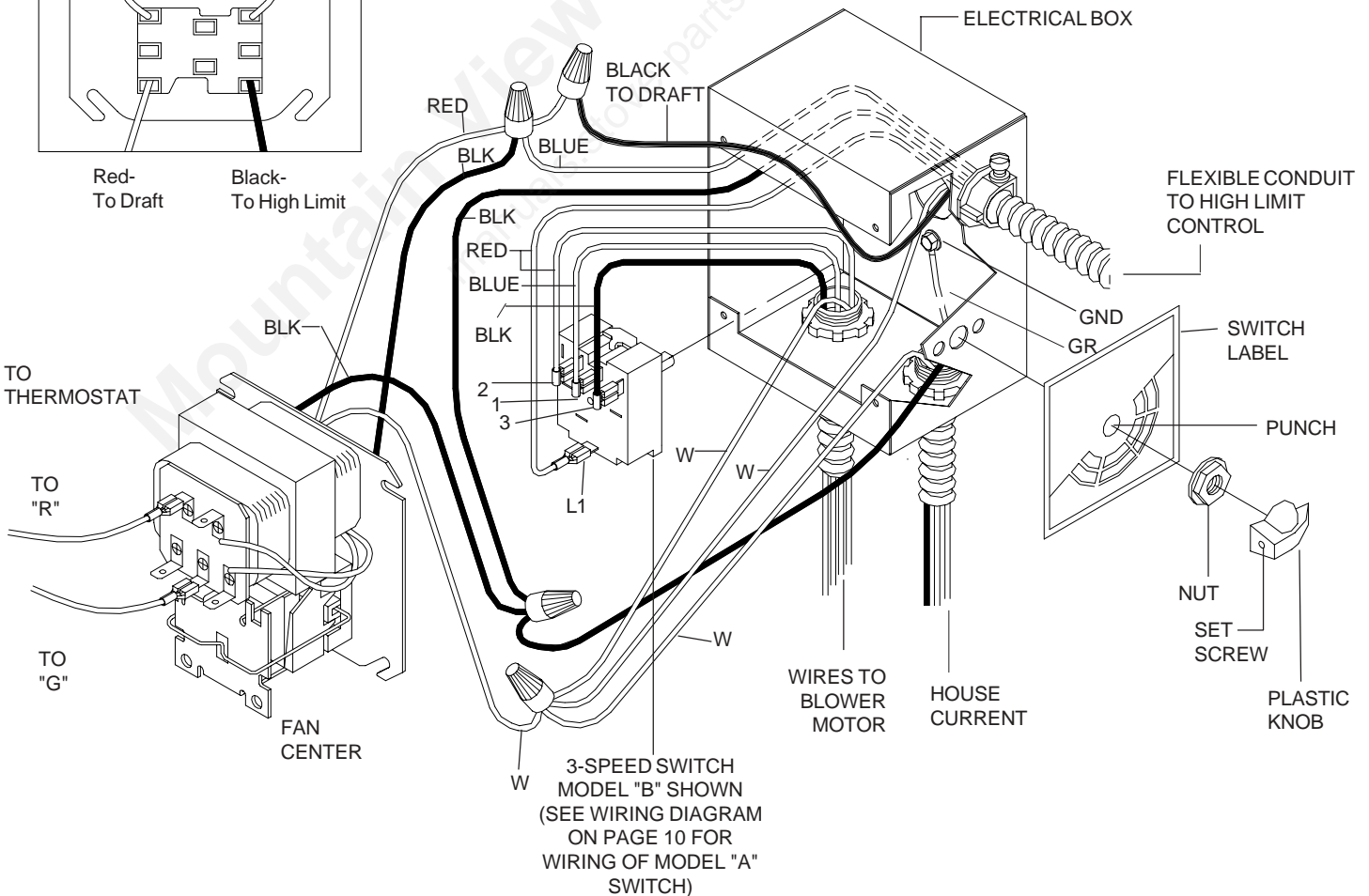

WIRING DIAGRAM

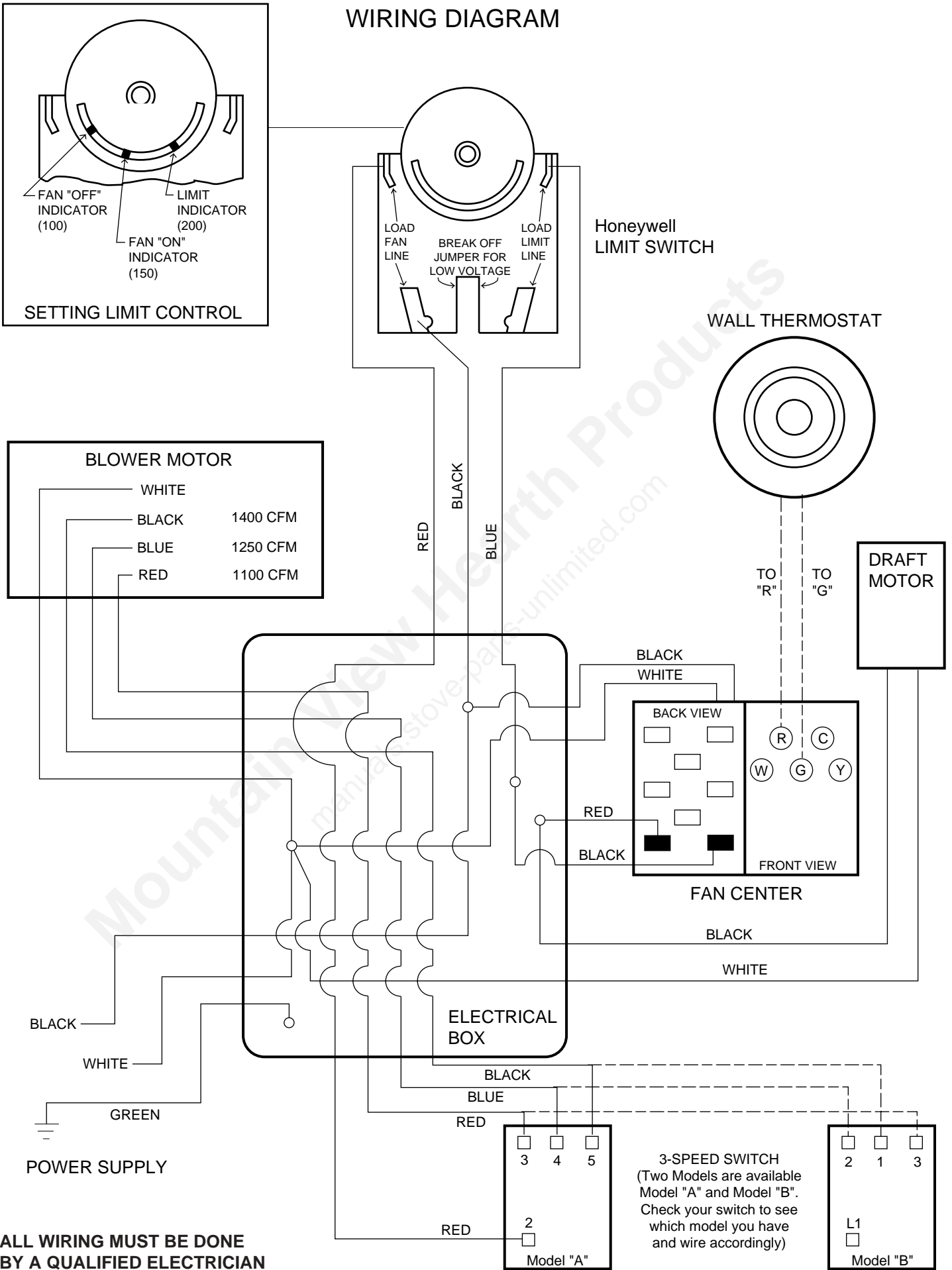

ALL WIRING MUST BE DONE BY A QUALIFIED ELECTRICIAN

TESTING AND OPERATING PROCEDURES

TESTING:

1. If using an optional power draft, check the draft blower by turning the room thermostat up high enough so that the draft blower turns on. Then lower the thermostat setting until you hear it shut off.
2. Use a sheet of newspaper to test your draft by placing it inside the furnace and lighting it.

With completion of the tests above, you are ready to light the furnace. Follow the operating steps.

STARTING A WOOD FIRE Using Motorized Natural Draft

CAUTION: Never use gasoline, gasoline-type lantern fuel, kerosene, charcoal lighter fluid, or similar liquids to start or "freshen up" a fire in the furnace. Keep all such liquids well away from the furnace while it is in use.

1. Turn up thermostat to open motorized damper.
2. Open spin draft cap on ash door.
3. Pull the slide baffle rod to the front position.
4. Open the fuel load door and light fire using kindling and several sheets of newspaper, then close the furnace door. The furnace door should remain closed for 5 to 10 minutes in order to establish the fire. If the fire has established, you are ready to load the furnace.

CAUTION: To prevent flame and smoke spillage, the slide baffle must be pulled out and the fuel door must be cracked for ten seconds before being fully opened.

Do not over fire your furnace! After you have become familiar with its operation, you should know how much wood to use.

4. Load the furnace, close the load door and push the slide baffle rod to rear.
5. Close the spin draft cap on ash door.
6. The motorized natural draft cycles on demand from the U.S. Stove wall thermostat. Setting the thermostat four degrees higher than your existing thermostat is recommended.
During operation, the motorized natural draft remains open until the thermostat temperature setting is reached.

CAUTION: To avoid excessive temperatures, do not operate with fuel door or ash pan open.

STARTING A WOOD FIRE Using Forced Air Draft

Shut off FAD when fuel door is open.

CAUTION: Never use gasoline, gasoline-type lantern fuel, kerosene, charcoal lighter fluid, or similar liquids to start or "freshen up" a fire in the furnace. Keep all such liquids well away from the furnace while it is in use.

1. Open spin draft cap on ash door.
2. Pull the slide baffle rod to the front position.
3. Open the fuel load door and light fire using kindling and several sheets of newspaper, then close the furnace door. The furnace door should remain closed for 5 to 10 minutes in order to establish the fire. If the fire has

established, you are ready to load the furnace.

CAUTION: To prevent flame and smoke spillage, the slide baffle must be pulled out and the fuel door must be cracked for ten seconds before being fully opened.

Do not over fire your furnace! After you have become familiar with its operating, you should know how much wood to use.

4. Load the furnace, close the load door and push the slide Baffle rod to rear.
5. Close the spin draft cap on ash door.
6. The forced air draft cycles on demand from the wall thermostat. Setting the U.S. Stove thermostat four degrees higher than your existing thermostat is recommended. In operation, the power draft blower will run until the U.S. Stove thermostat temperature setting is reached. The draft regulator on the forced air draft is preset at the factory and should require no adjustment.

CAUTION: To avoid excessive temperatures, do not operate with fuel door or ash pan open.

STARTING A COAL FIRE If you burn coal a Forced Air Draft is required.

Shut off FAD when fuel door is open.

- ✓ Open smoke pipe damper all the way. Open all draft controls on your 1600/1800. Pull the slide baffle forward.
- ✓ Place about 10-15 lbs. of coal in on the shaker grates. It should come up to about half of the first firebrick level.
- ✓ Place crumpled paper over the coal and criss-cross a couple handfuls of dry kindling wood 3/4" in thickness on top of paper.
- ✓ Ignite the paper and close loading door. Wait about 30 minutes until coal fire is established before adding more coal. NOTE: NEVER load coal over the level of firebrick.
- ✓ Close by-pass damper and set all draft controls to your own needs. It may take 3 to 4 coal fires to determine how your local coal and the Hotblast Furnace reacts together — adjusts drafts accordingly.
- ✓ Loading with a good bed of coals in the morning — open by-pass damper.

1. In normal shaking, only rock the grates a small amount to sift ash through.

2. Remove all ashes every day from ash pit.

CAUTION: Ashes should be placed in a metal container with a tight fitting lid. The closed container of ashes should be placed on a non-combustible floor or on the ground well away from all combustible materials pending final disposal. If the ashes are disposed of by burial in soil or otherwise locally dispersed, they should be retained in the closed container until all coals have thoroughly cooled.

3. With your poker, push hot burning embers to the rear of the unit and add green coal in front. NEVER load over height of firebrick. This can result in damage to your furnace and home.

4. Close by-pass damper.

- ✓ Too much draft air will cause clinkering of coal and will waste heat up the chimney. Shut draft down to as low a point as you can and still heat your home.

1. NOTE: Never stand in front of loading door when opening it. Stand to the side.

2. NEVER completely cover the live fire with fresh coal. Always leave a generous area of burning coal at the top of the fire and at the rear.
 3. Always keep the ash pit clean.
- ✓ If the fire goes out or does not hold overnight, look for:
1. Poor draft.
 2. Incorrect damper settings.
 3. Improper firing methods for coal being used.
 4. More combustion air needed.
 5. Coal not sized to the furnace. We recommend 1" to 3" diameter pieces of coal.
 6. Ashes, if allowed to accumulate in the ash pit, will not allow the passage of required air for combustion. Keep ash pit clean.
 7. This furnace is not to be used with an automatic stoker unless so certified.

OPERATING NOTES

Do not over draft the furnace! It is designed to operate at .06 inches of water column and must be set with a draft gauge to maintain a steady draft. (Barometric Damper recommended.)

Do not allow ashes to build up higher than 2" above grates.

Be extremely careful when removing furnace ash pan; it can get very hot.

With new steel, there is a small amount of oil or dirt on the metal. You may smell an odor. This is normal during the first operation. You may want to assemble the furnace out of doors and build a small fire in it to "burn off" this dirt and oil before installing the unit.

The furnace is designed to burn air dried wood and coal at a predetermined firing rate. Over firing could result in damage to the heat exchanger and cause dangerous operation. Over firing occurs when the ash door is left open during operation or a highly volatile fuel, i.e. large amounts of small kindling, is used.

When tending the firebox always pull the baffle slide rod out prior to opening load door. Open load door slowly to avoid a "flash back". After closing load door, push the baffle slide rod to the rear.

Equip your home with fire extinguishers and smoke detectors appropriately located.

Inspect air filters regularly. The air filter in the filter box should be changed at least every 30 days.

Oil motor on forced air draft every 90 days with a few drops of 30 wt. oil.

The distribution blower motor motor may be one of two types. If the motor has sealed bearings, no oiling is required.

If the motor is equipped with fill holes, the motor should be oiled every 90 days with several drops of 30 wt. oil.

Check the fit on the load door. It must fit tightly. If it does not, check for deterioration or wear of the ceramic rope seal. Replace defective seals.

Inspect and clean your chimney and stove pipe regularly.

In event of chimney fire, shut all draft controls and call your fire department immediately. Alert everyone in the house. If the fire is still burning vigorously, throw baking soda into firebox or discharge a fire extinguisher into the firebox. After chimney fire is over, completely inspect system for damage before further use.

Slow fires: It is not recommended burning the U.S. Stove

furnace any more than necessary early in the fall and late spring, as you cannot keep the firebox hot enough (without overheating your home) to burn gases. Slow fires can cause excessive creosote build-up in smoke pipe, chimney and firebox.

Wood should be placed directly onto the cast iron shaker grate of the U.S. Stove furnace. Do not use additional grates and/or irons.

In the event of a power failure, you may operate the 1600/1800 furnace provided the following instructions are followed:

1. Any air filter should be removed.
2. If the motorized natural draft is used, the draft cap is to be set at a 1/2 inch opening. If the forced air draft is used, the damper on the built-in draft regulator will automatically open to the preset factory spacing.
3. Do not burn garbage, plastics, gasoline, drain oil or other flammable liquids. Plastics, when burned, form hydrofluoric and hydrochloric acids which will damage and destroy your furnace pipe and chimney. The burning of trash or oil can result in an extremely hot fire and is sometimes a cause of chimney fires.

NEVER BURN GREEN WOOD OR TIRES.

Do not store fuel or other combustible material within marked installation clearances.

NOTE: For further information on using your furnace safely, obtain a copy of the National Fire Protection Association publication "Using Coal and Wood Stoves Safely." NFPA NO. NW-8-1974. The address of the NFPA is 470 Atlantic Ave., Boston, Massachusetts 02210.

**THIS IS A WOOD AND COAL
BURNING FURNACE AND
SHOULD NOT BE ALTERED
IN ANY WAY!**

TROUBLE SHOOTING AND PROBLEM SOLVING

1. Problem:

Smoke puffs from furnace

Solution:

- A. Check chimney draft. Check for blocked chimney or flue pipe. Use mirror to check chimney clearance.
- B. Check ash pit — if it is too full, empty.
- C. Make sure furnace room is not too airtight.
- D. Make sure all of chimney mortar connections are airtight.
- E. Check ash drawer. Make sure it's airtight.
- F. Check chimney for possible down-draft caused by taller surrounding trees or objects. Correct with proper chimney vent cap.
- G. Check the possibility of a cold chimney forcing cool gases backward. Remedied by properly insulating chimney with non-combustible liner — non-combustible insulation.
- H. Fuel may be too green.
- I. Make sure no other fuel burning devices are connected to the chimney impairing the draft.
- J. Check chimney draft, it should be .06 inches of water column.

2. Problem:

Inadequate heat being delivered to your home

Solution:

- A. Check home insulation — is it adequate?
- B. Check hook-up to furnace — is it installed correctly?
- C. Cool air inlet may be inadequate or furnace room too airtight.
- D. Your wood fuel may be too low grade. Hardwoods are recommended.
- E. Make sure your hot air duct (and other duct work) is airtight.
- F. If furnace room is warm but your home isn't, check back draft dampers.
- G. Is air to the blower available?

3. Problem:

Excess smoke or flames coming out door when refueling

Solution:

- A. Wait 15 seconds and open door SLOWLY — then refuel.
- B. Check length of flue pipe to chimney. Your unit should be within six (6) feet of your chimney.
- C. Make sure chimney cap is not too close to the top of the chimney.

- D. Check chimney draft — make sure chimney flue pipe is clean and chimney is of adequate height.
- E. Make sure you're not suffocating the fire with excessive amounts of unburned wood.
- F. Slide baffle should be pulled out prior to load door opening.

4. Problem:

Distribution blower vibrating

Solution:

- A. Tighten blower wheel to motor shaft.
- B. Check for bad fan bearings.

5. Problem:

Distribution blower continues to run or will not run

Solution:

- A. Check fan limit or heat sensor and cable.
- B. Check to see that blower is properly wired. (See Wiring and Assembly Instructions).
- C. Check fuse box or power source.
- D. Check power supply.

6. Problem:

Draft blower continues to run or will not run

Solution:

- A. Check wiring.
- B. Check thermostat or thermostat wire for short.
- C. Make sure temperature is calling for heat.

7. Problem:

Odor from first fire

Solution:

- A. The odor from new steel should disappear in a few hours.
- B. If the odor remains, call you dealer immediately. A bad weld can cause a fume leak.

8. Problem:

Excessive Creosote

Solution:

- A. Check the grade of wood you are burning.
- B. Make sure your unit is serviced by its own proper chimney.
- C. Check length of flue pipe and its connections.
- D. Make sure you are burning the smallest, hottest fire to adequately heat your home.
- E. Also see Solutions to Problem one.

PARTS LIST

MODEL 1600/1800

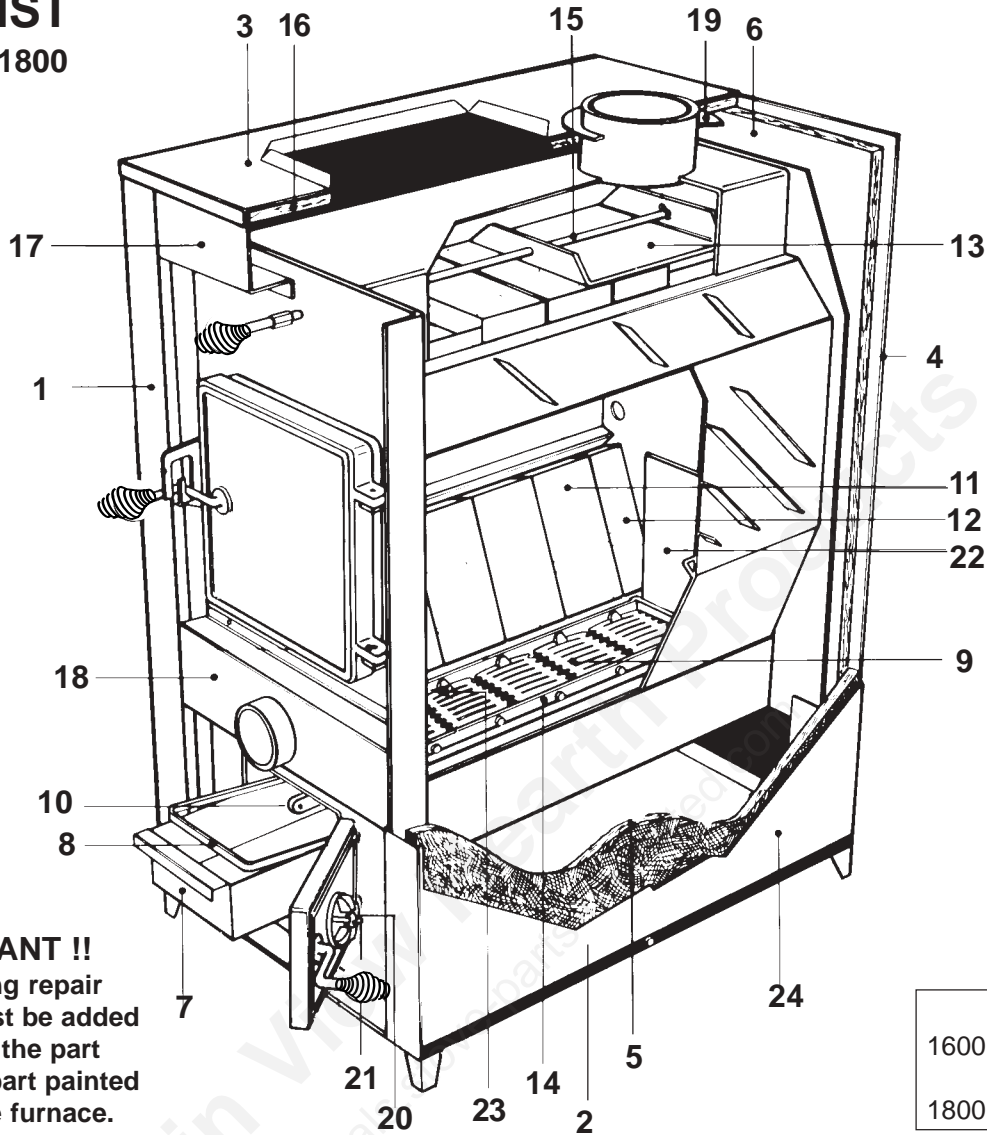

!! IMPORTANT !!
 When ordering repair parts, a "G" must be added to the end of the part number of any part painted **GREEN** on the furnace.

NOTE:
 1600 = 16 - FULL BRICK
 1 - HALF BRICK
 1800 = 22 - FULL BRICK

ITEM	DESCRIPTION	MODEL	PART#
1	Left Side Front Assy.	1600	68821
		1800	68962
2	Right Side Front Assy.	1600	68822
		1800	68961
3	Top Wrapper	1600	69088
		1800	68964
4	Back Weldment	1600	68823
		1800	68963
5	Side Insulation (2ea.)	1600	C98771
		1800	23977
6	Back Insulation	1600	C98971
		1800	23978(2)
7	Ash Pan Weldment	1600	68882
		1800	68919
8	Carrying Handle	1800	24233
9	Shaker Grate Section	1600	23852
		1800	68914
10	Shaker Bar	1600	C000047
		1800	23961
*	Snap in Receptacle	BOTH	80351

ITEM	DESCRIPTION	MODEL	PART#
11	Full Brick	BOTH	89066
12	Full Brick	1600	23887
13	Slide Baffle Plate	BOTH	24231
14	Grate Retainer	1600	40312(2)
		1800	40337(2)
15	Baffle Rod S/S	1600	C10871
		1800	89704
16	Top Insulation	1600	C98871
		1800	23979(2)
17	Front Filler	1600	23817
		1800	24190
18	Draft Cover	1600	23818
		1800	24508
19	Top Flue Ring	1600	22761
		1800	23958
20	Draft Cap	BOTH	23859
21	1/2" x 2-1/2" Bolt	BOTH	C20599
22	Back Liner	1600	40313
		1800	40339
23	Front Liner	1600	40344
		1800	40338
24	Cabinet Side Back	1800	69002

* = NOT SHOWN

PARTS LIST

MODEL 1600/1800

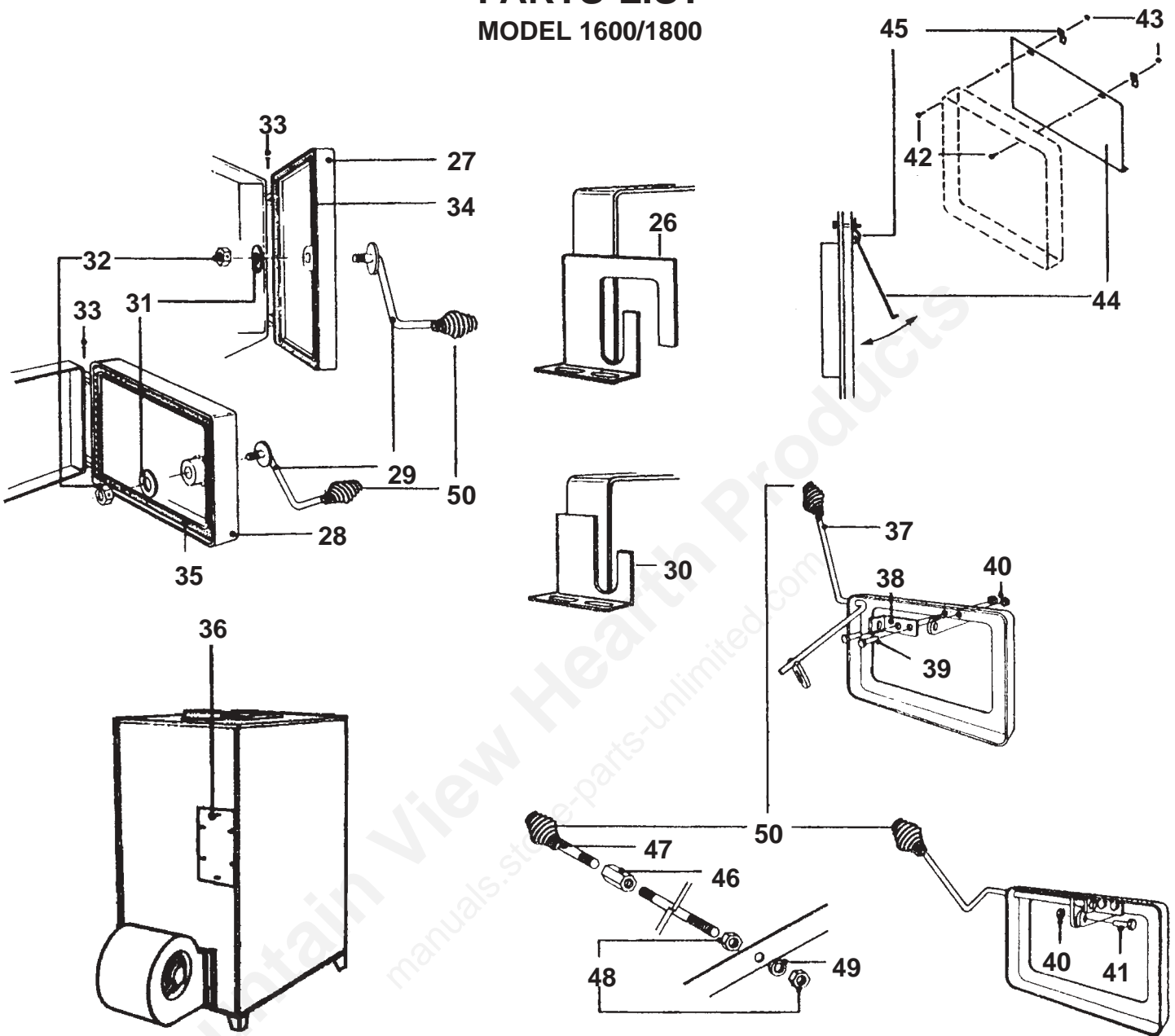

ITEM	DESCRIPTION	PART#
26	Top Safety Latch	23786
27	Feed Door (Drilled)	69091
28	Ash Door (Drilled)	68880
29	Door Latch Handle	24179(2)
30	Ash Door Latch	23823
31	1/2" Flat Washer	83835(2)
32	1/2" Lock Nut	83444(3)
33	5/16" x 1" Hinge Pin	C21399(4)
34	1/2" Rope for Fire Door 52"	88057
35	1/2" Rope for Ash Door 32"	88057
36	Aqua-Siphon Cover	23819
37	Shaker Grate Handle	C000177
38	Hinge Bracket	24204

ITEM	DESCRIPTION	PART#
39	1/4" x 3/4" Hex Bolt	83339(6)
40	1/-20 Kep Nuts	83250(8)
41	1/4" x 1" Hex Bolt	83379
42	1/4" x 1-1/4" Carriage Bolt	83445(2)
43	1/4-20 Kep Nut	83250(2)
44	Smoke Door Curtain	23800
45	Smoke Door Clip	23787(2)
46	1/2" x 1-1/2" Hex Connector	C21899
47	Baffle Rod Extension	C000089
48	1/2" Hex Nut	83276(2)
49	1/2" Coupling	C21899
50	Brass Coil Knob	89574(4)
	Feed Door Assembled	68829
	Ash Door Assembled	68880

PARTS LIST

MODELS 1600 / 1800 Fan Limit Kit #C68399

ITEM	DESCRIPTION	PART#
1	High Limit Control	80145
2	3-Speed Switch	80361
3	Plastic Knob	C9267M
4	Fan Center	80130

MODEL 1600 Blower Kit #C60471 (1400CFM)

MODEL 1800 Blower Kit #C6137M (1800CFM)

ITEM	DESCRIPTION	PART#
5	3-Speed Motor 1/3 hp	C45799
6	Blower Housing (1600)	C46799
	Blower Housing (1800)	C45899

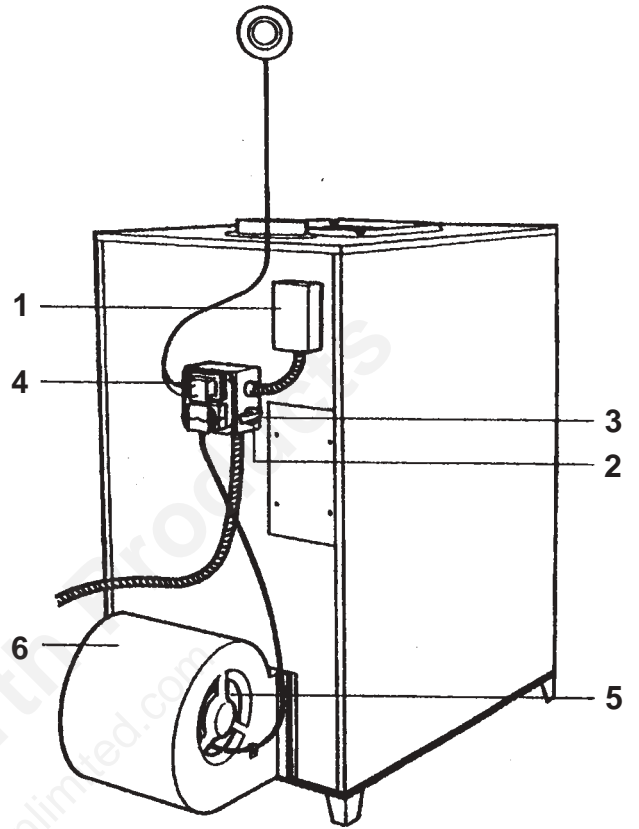

MOTORIZED NATURAL DRAFT PARTS LIST

PRE-ASSEMBLED AT FACTORY
(OPTIONAL KIT)

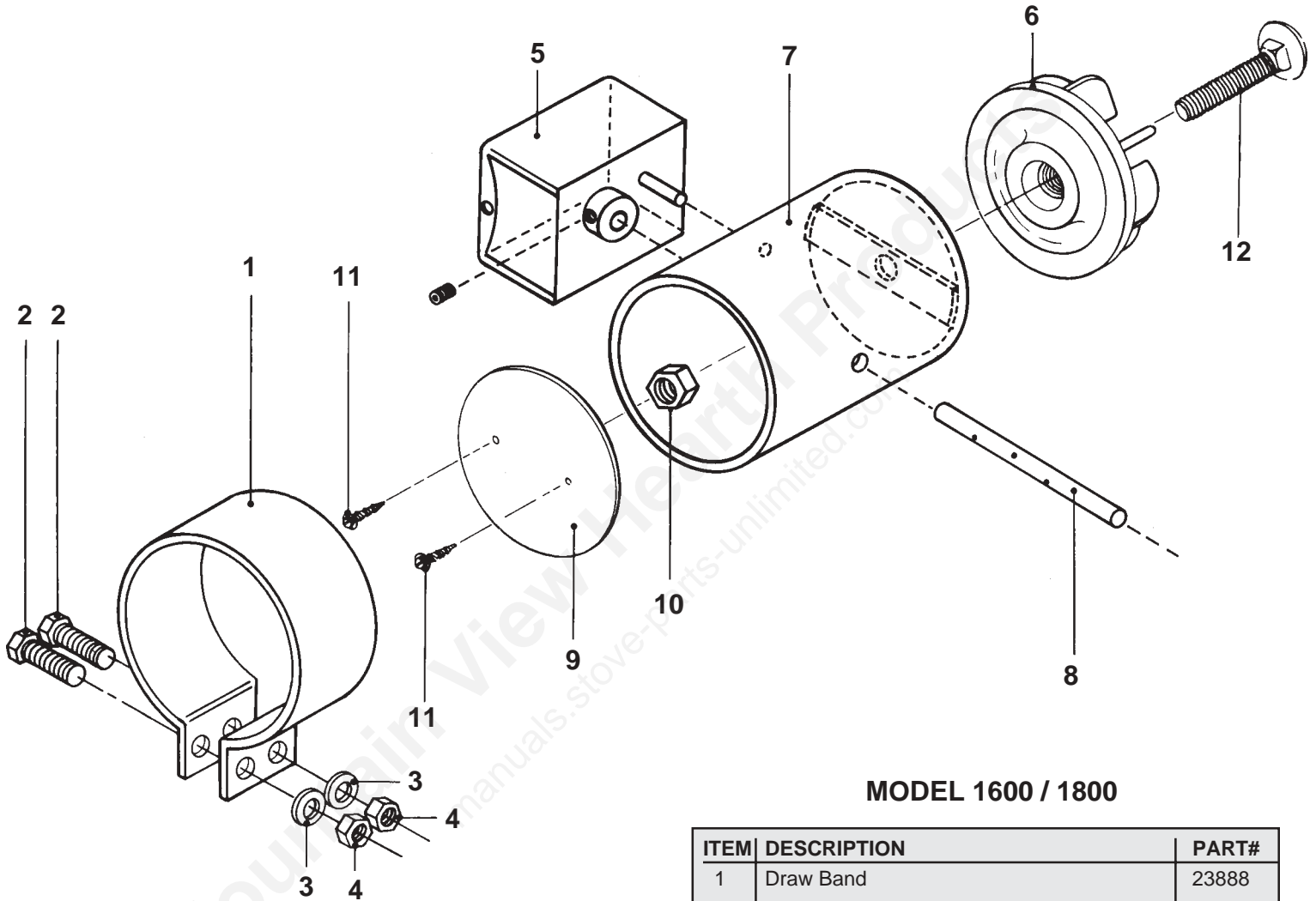

MODEL 1600/1800
MND KIT #C60357M

MODEL 1600 / 1800

ITEM	DESCRIPTION	PART#
1	Draw Band	23888
2	1/4" x 1" Bolt	83379
3	1/4" Lock Washer	83414
4	1/4" Hex Nut	83072
5	Erie Motor-120v	C45099
6	Draft Cap	23859
7	Draft Tube Weldment	68872
8	Flipper Tube	23899
9	Flipper	23898
10	1/2" - 13 Hex Lock Nut	83444
11	#8 x 1/2" Tek Screw	83455
12	1/2 x 2-1/2 Carriage Bolt	C20599
*	Thermostat	80129

FORCED AIR DRAFT PARTS LIST

PRE-ASSEMBLED AT FACTORY

MODEL 1600/1800
KIT #69189

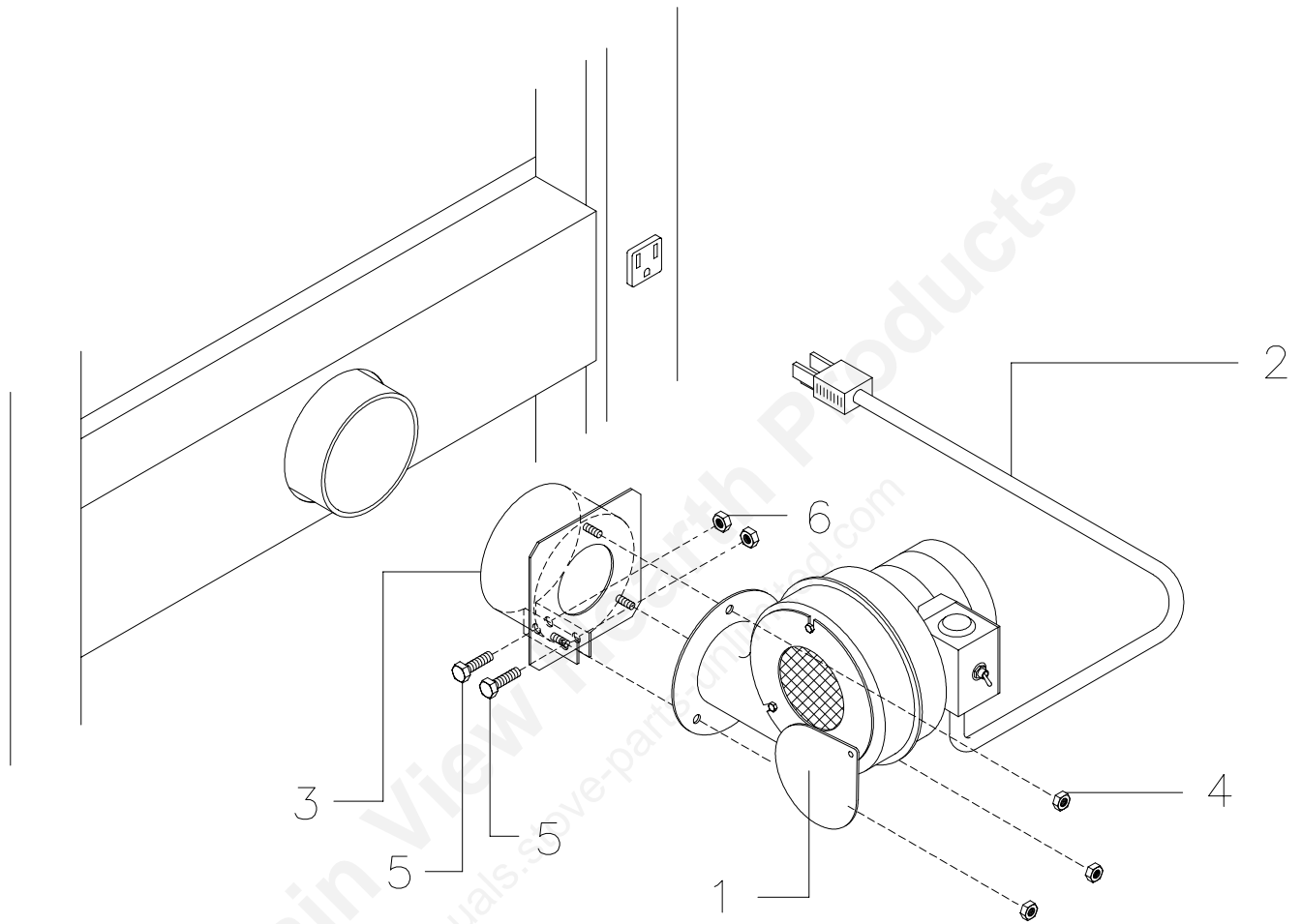

ITEM	DESCRIPTION	PART#
1	Draft Blower	80422
2	Power Supply Cord	C40899
3	FAD Bracket	69192
4	10-24 Kep Nut (3ea.)	83244
5	1/4-20 x 1" Bolt (2ea)	83379
6	1/4-20 Lock Nut	83261

OPTIONAL ELECTRONIC CONTROL SYSTEM

INSTALLATION INSTRUCTIONS

1. Remove top of furnace.
2. Attach heat sensor "L" bracket to pins located on underside of furnace top (see illustration).
3. Mount heat sensor in "L" bracket and run cable from sensor between insulation and furnace top.
4. Feed cable down behind back insulation and pull cable through hole on back of furnace.
5. Attach control box to back of furnace and wire per instructions.

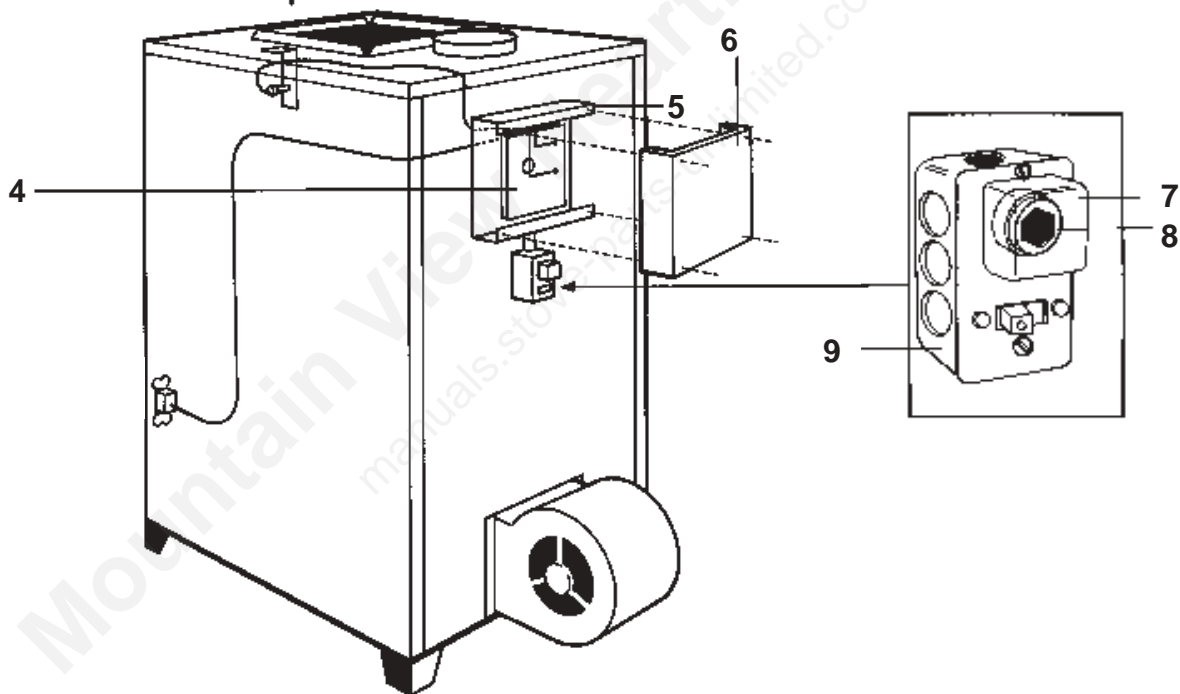
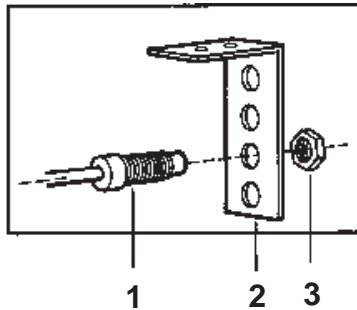
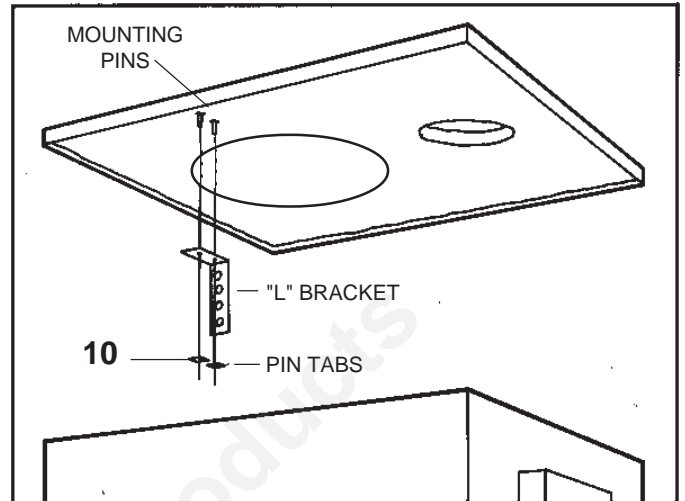

PARTS LIST

MODEL 1600 / 1800

ITEM	DESCRIPTION	PART#
1	Heat Sensor	C47314
2	Heat Sensor Mounting Clip	CL00084
3	3/8" Hex Nut	C20699
4	Electronic Circuit Board - 1988	C45599
5	Circuit Board Box	CL00087

ITEM	DESCRIPTION	PART#
6	Box Cover	CL00085
7	Utility Box Cover	C40399
8	10 Amp Fuse - W10 Fast Blow	C40499
9	Raco Box	C40299
10	Pin Tabs	C99799

WIRING INSTRUCTIONS

ELECTRONIC CONTROL CENTER

All electrical wiring should be performed by a qualified electrician.

ONCE ALL CONNECTIONS HAVE BEEN MADE, REPLACE BOX COVER AND SECURE WITH (4) - 8 X 1/2" TEK SCREWS.

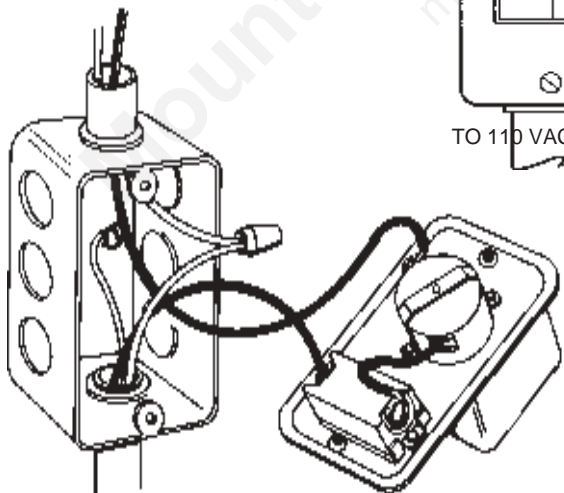
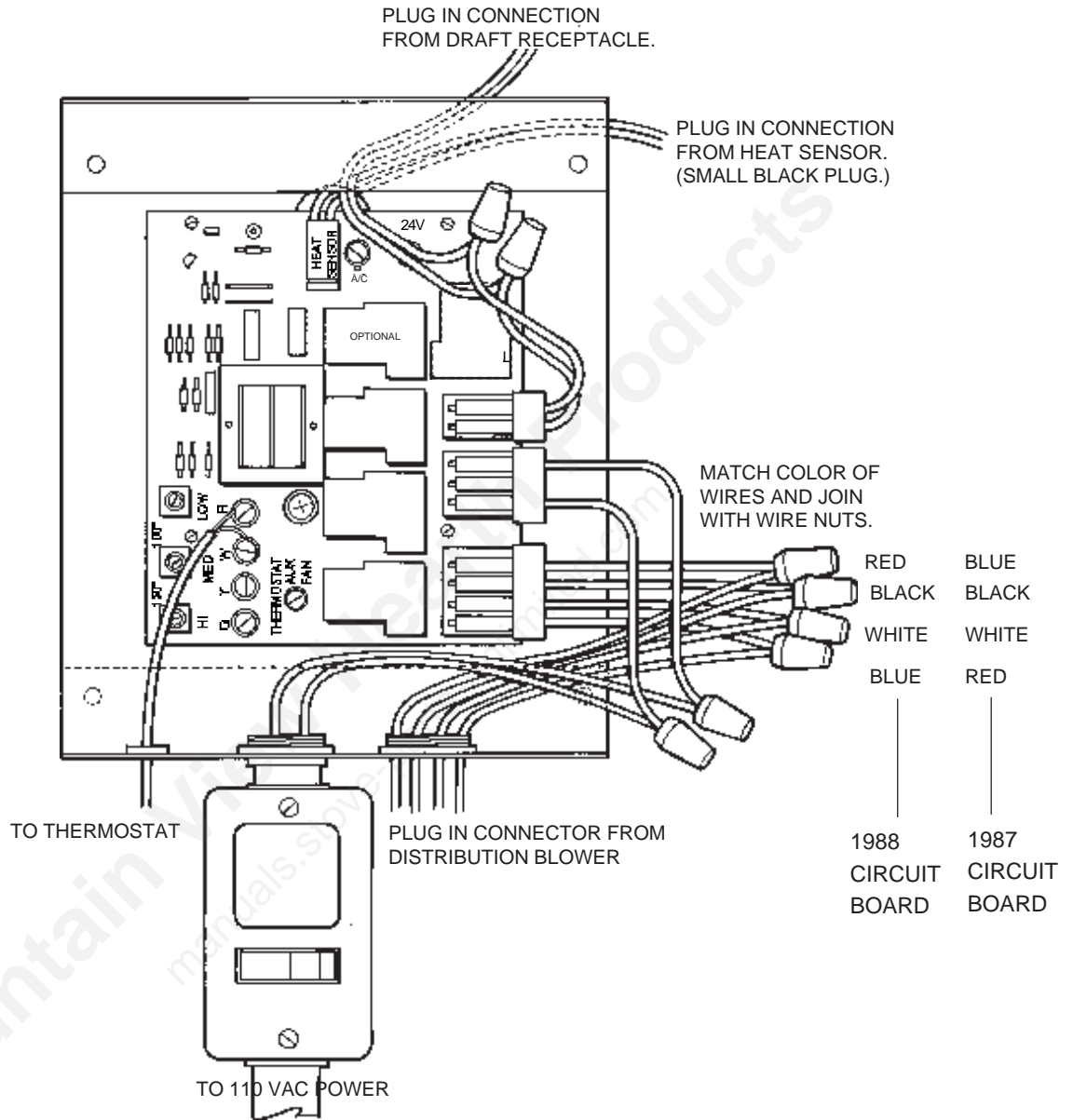

NOTE: DAMAGE TO HEAT SENSOR WILL PREVENT UNIT FROM OPERATING PROPERLY.

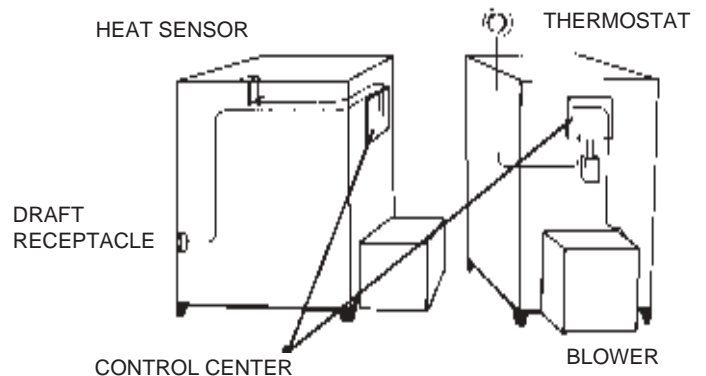

CAUTION
USE NO MORE THAN A 10 AMP FAST-BLO FUSE

3-SPEED BLOWER ADJUSTMENT

The control center is equipped with three adjustments that allow you to select the temperature at which the blower starts operating and automatically switches from one speed to the next.

With the three controls you can set the blower for single (high speed operation), two speed operation, or three speed operation.

The High-Only setting is usually recommended for larger structures where the maximum air flow is required to achieve efficient, uniform heating. (Improper adjustment can cause undesirable cycling.)

The two or three speed settings are more applicable to smaller or medium sized structures and generally make more efficient use of the available heat. Because the blower speeds can be set to automatically change as the plenum temperature increases or decreases, the heat output can be maintained at a more uniform level throughout the cycle of the fire.

The temperature range shown on each control corresponds to the air temperature as measured at the furnace plenum.

INITIAL FACTORY SETTING FOR 3 SPEED OPERATION.
(For any other blower setting see chart)

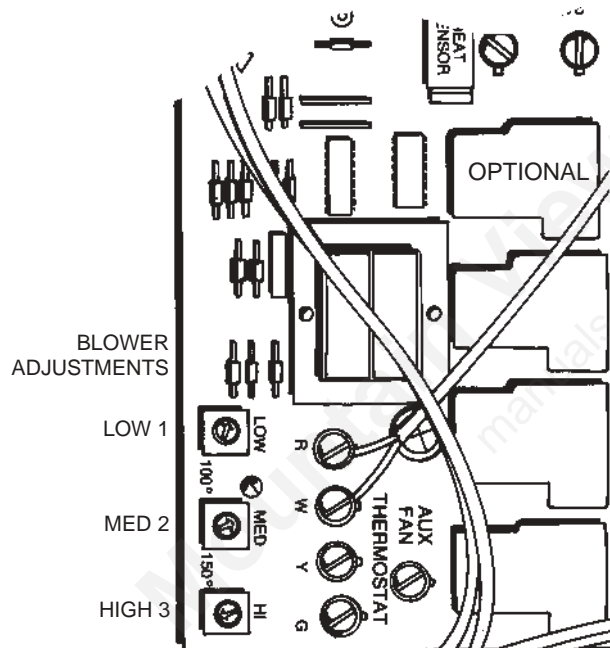

USE SMALL SCREWDRIVER (SUPPLIED)
TO MAKE FURTHER ADJUSTMENTS

NOTE: BLOWER MOTOR CFM'S FOR THE 1600/1800 ARE:
BLUE-1250 CFM
BLACK-1400 CFM
RED-1100 CFM

Refer to the following chart to select the blower speed options.

BLOWER OPERATION	CONTROL	SETTING
One Speed (HIGH) All 3 board wires connected to high speed wire of blower. Tape off low and medium wires to avoid accidental shorting.	1	Turn to temperature where you wish blower to start.
	2	Set at 150°
	3	Set at 150°
Two Speed (MEDIUM AND HIGH) Connect low speed board wire to medium speed blower wire. Connect medium and high speed board wires to high speed blower wire. Tape off low speed blower wire to avoid accidental shorting.	1	Turn to temperature where you wish blower to start.
	2	Set at least 5° higher than Control 1.
	3	Set at 150°
Three Speed (LOW, MEDIUM, AND HIGH)	1	Turn to temperature where you wish blower to start.
	2	Set at least 5° higher than Control 1.
	3	Set at least 5° higher than Control 2. (Initial factory setting: Control 1 - 110° Control 2 - 120° Control 3 - 140°)

If you find the air from the heat registers is too cool, turn Control 1 to a higher temperature setting. The setting of Control 3 for two speed operation and Controls 2 and 3 for three speed operation may also be adjusted up or down to maintain a more constant temperature output.

3 Speed Distribution Blower Operation

- when thermostat calls for heat: L-M-H, H-M-L
- when thermostat isn't calling for heat: H, H-M-L

WIRING DIAGRAMS FOR ELECTRONIC CONTROL SYSTEM

For Model 1600 / 1800

**STANDARD WIRE
(Diagram #1)**

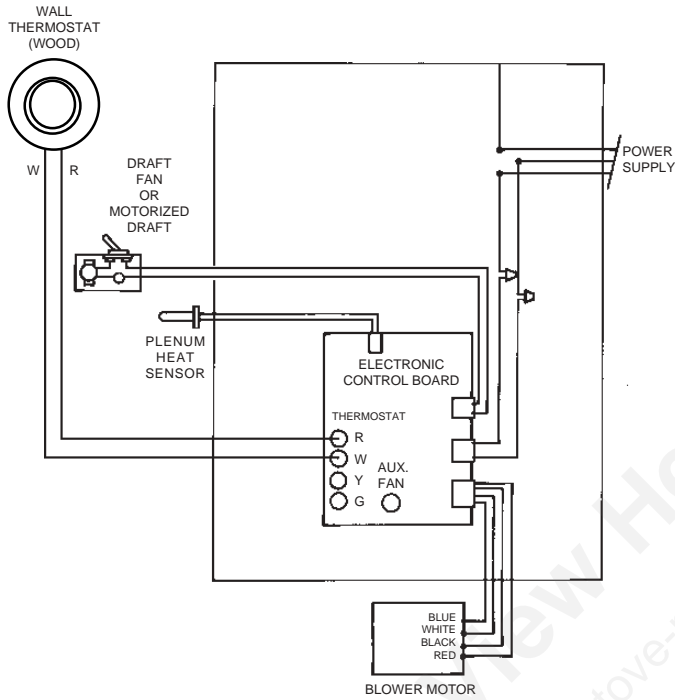

**HEATING OPTION
(Diagram #2)**

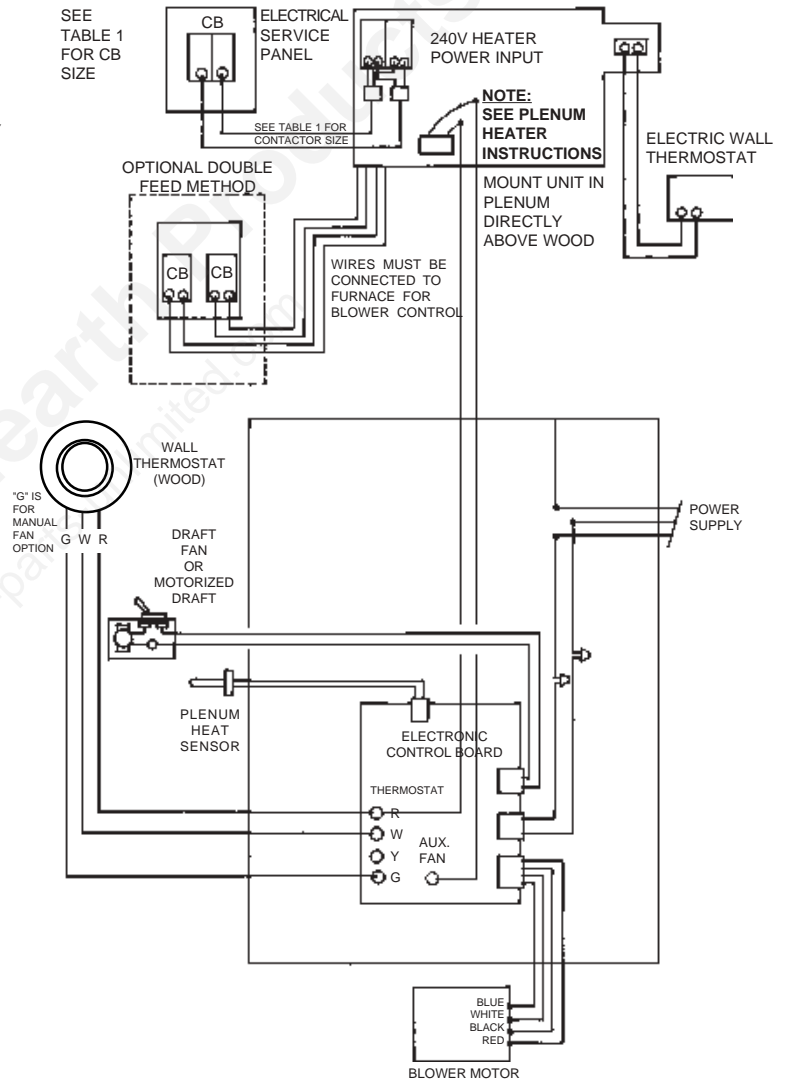

WIRING DIAGRAMS

For Model 1600 / 1800

**AIR CONDITIONING OPTION
(Diagram #3)**

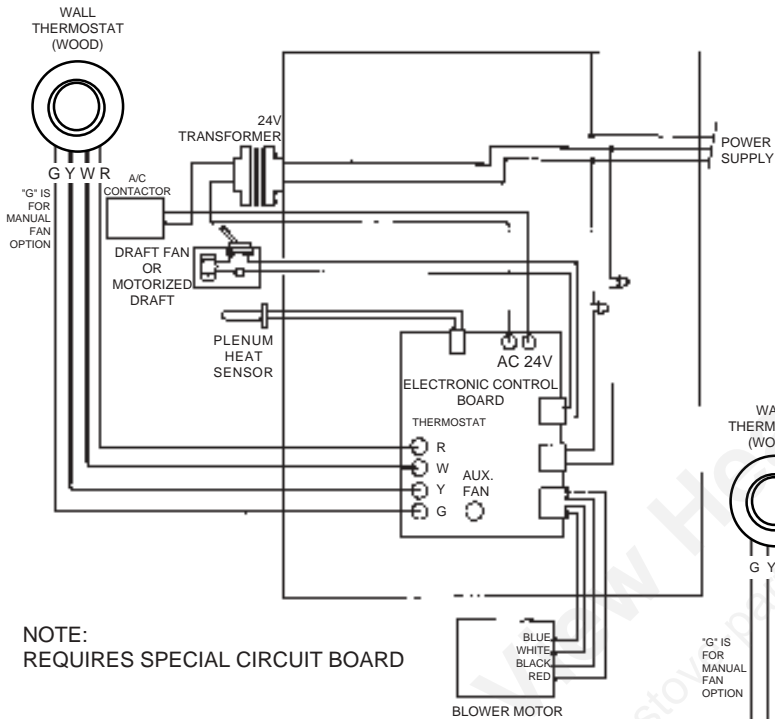

**HEATING & AIR CONDITIONING OPTION
(Diagram #4)**

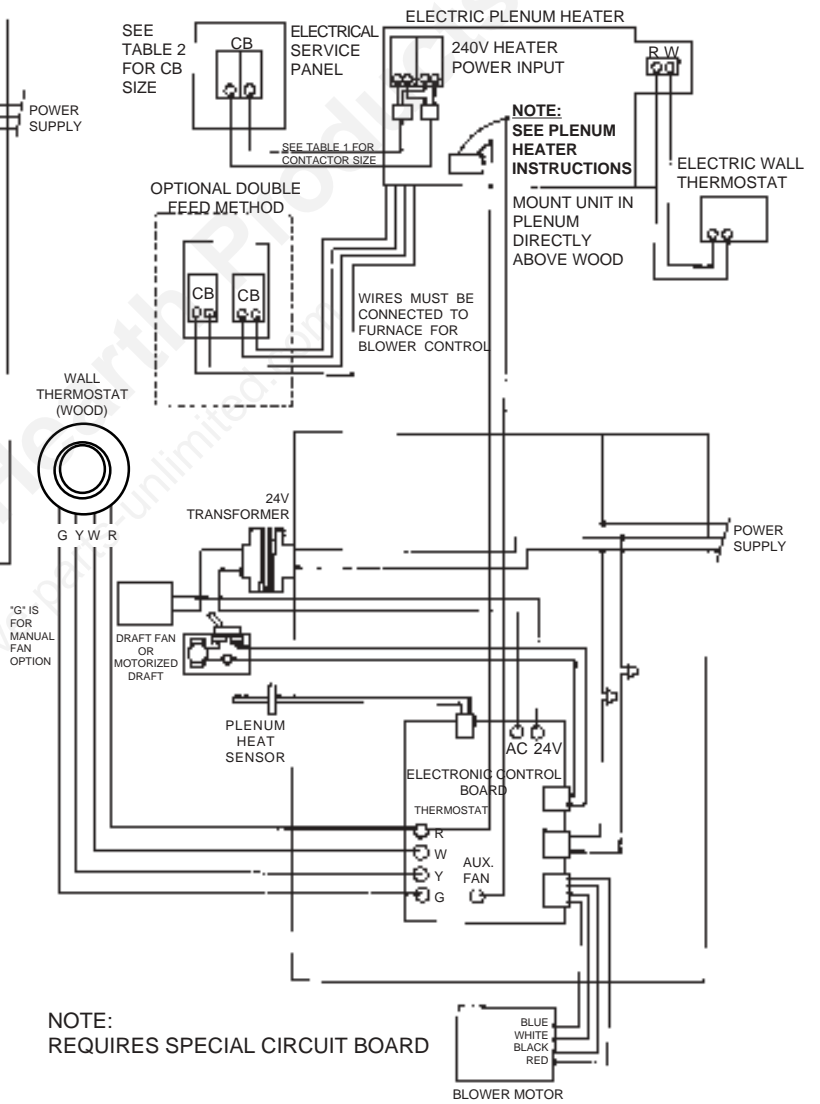

INSTALLATION OF OPTIONAL EQUIPMENT

INSTALLING DOMESTIC HOT WATER COIL

1. Remove access panel at rear of enclosure.
2. With a utility knife cut out the section of fiberglass insulation directly behind the access panel.
3. Remove cover plate from rear of firebox.
4. Place one nut on each end of the coil and thread each as far as they will go.
5. Place the coil through the holes from the inside of the firebox and run a washer and nut down each leg on the outside of the stove. Before tightening the nuts down completely, wrap a piece of hi-temp fiberglass rope gasket, provided with the kit, around each threaded leg between the washer and the outside of the firebox. Tighten the nuts down securely to insure an airtight installation. The installation is now ready to be plumbed to your existing domestic hot water system. Choose one of the three methods described in the Hot Water Kit Installation Instructions.
6. Remove knockouts from access panel and attach to furnace enclosure.
7. Have a qualified plumber connect your domestic hot water pipe to the coil with appropriate fittings.

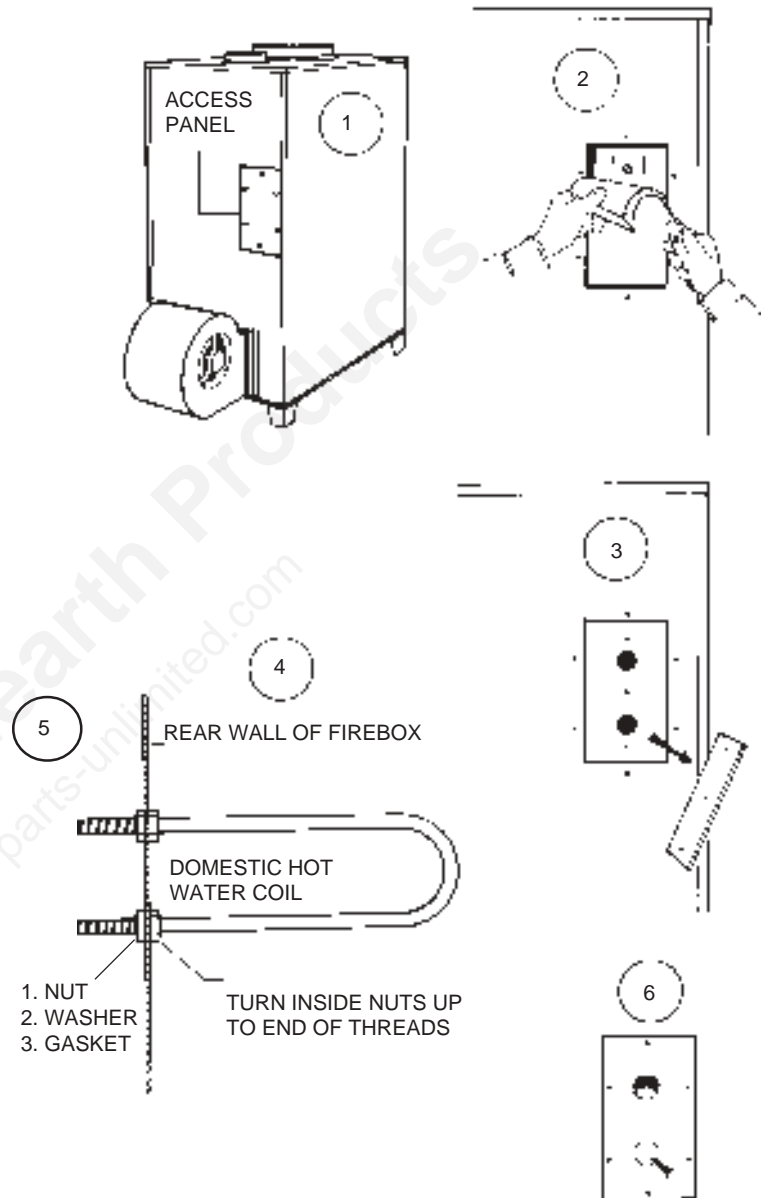

INSTALLING BACK DRAFT DAMPER

The back draft damper may be installed in either a vertical or horizontal section of the hot air duct. It should be positioned as close to the plenum opening of the furnace as practical. Press female end of the back draft damper over Hotblast Furnace collar or male end of the duct pipe. When properly placed the arrows on the air flow decal should point away from the furnace.

MEDIUM BACKDRAFT DAMPER KIT #C62145

LARGE BACKDRAFT DAMPER KIT #C62299

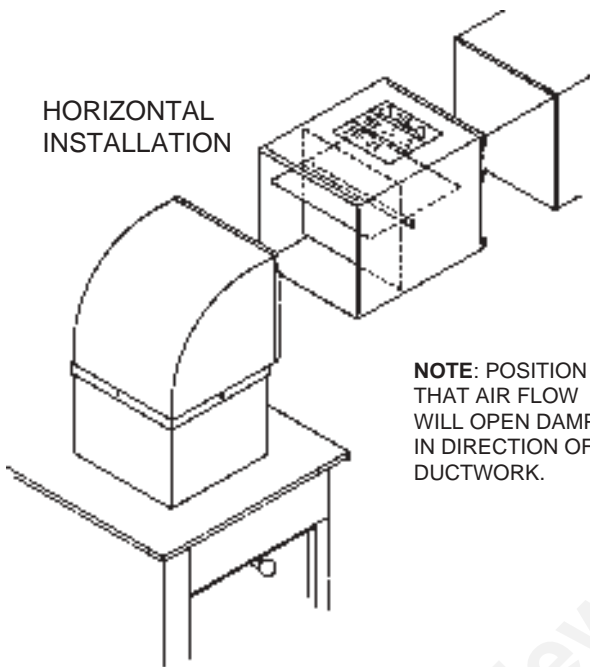

HORIZONTAL
INSTALLATION

NOTE: POSITION SO
THAT AIR FLOW
WILL OPEN DAMPER
IN DIRECTION OF
DUCTWORK.

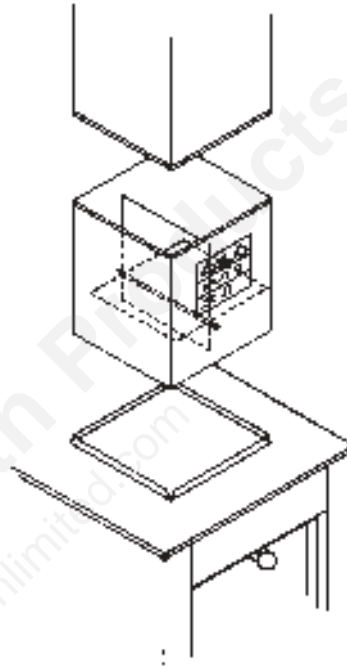

SEE PRODUCT
LABEL.

NOTE: POSITION SO
THAT AIR FLOW WILL
OPEN DAMPER FROM
BOTTOM.

VERTICAL
INSTALLATION

FILTER BOX OPTION MODEL 1600 / 1800

20" x 20" x 1" Filter Required

Assemble filter box sections in the order shown in the illustration and secure with sheet metal screws provided.

1. Assemble parts B and C to part E - bottom.
2. Attach to back of furnace.
3. Assemble part D to parts B and C.
4. Assemble part A - top, after you have attached filter box to furnace and blower is inside filter box on furnace.

NOTE: The side with the 18" square hole can be used as the right or left side. If you want filter on left side of furnace, part "B" should be as shown. If you want filter on right side of furnace, parts "B" and "C" should be reversed.

LARGE FILTER BOX KIT #C61899

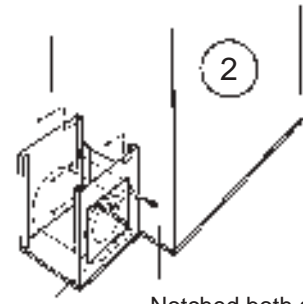

Notched both sides for Blower Wire.

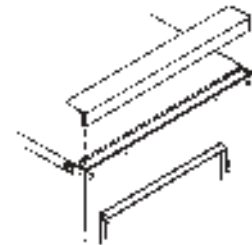
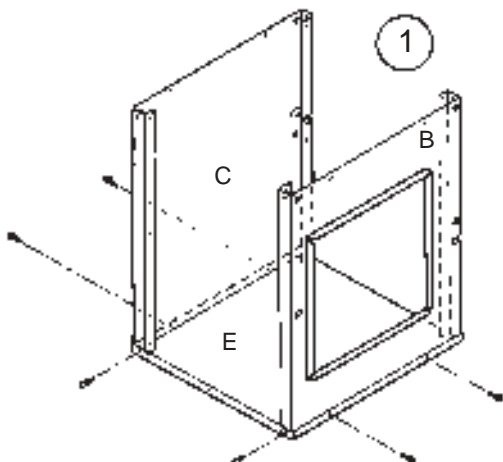
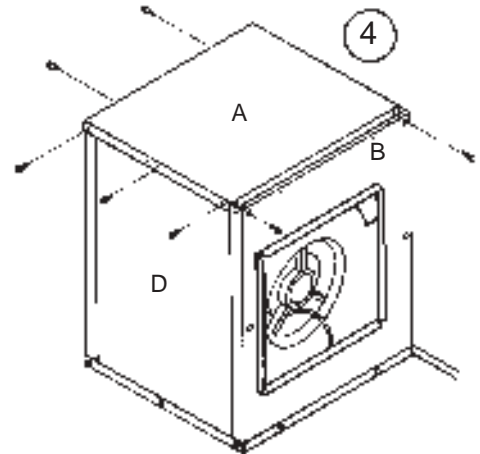
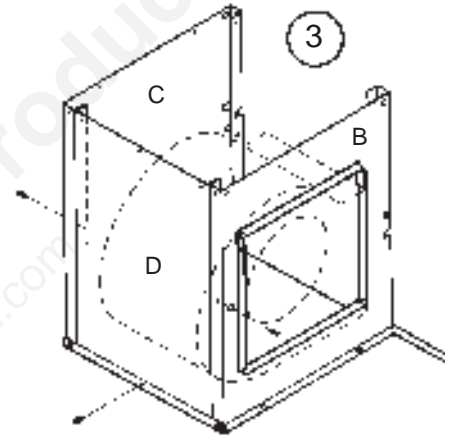

Insert the filter and slide the filter cap into place. The 18" square air intake can be fitted with a collar to accept a return cold air duct.

DELUXE FILTER BOX KIT #C61999

Model 1600 / 1800 (see service bulletin #2)

16" x 20" x 1" Filter Required

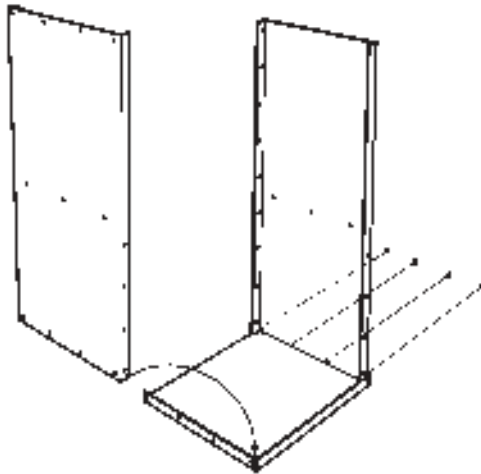

1. Attach sides of filter box to bottom with (4) sheet metal screws per side.

Be sure sides are inside bottom lips and positioned with predrilled holes as illustrated.

Side with no lip faces back of furnace.

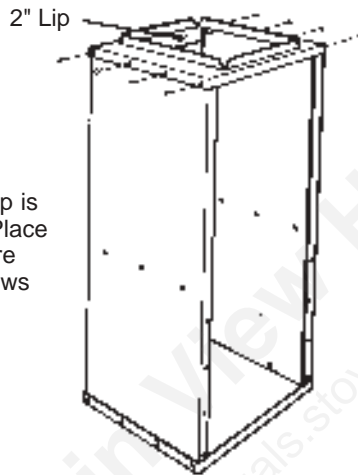

2. Position top so 2" wide lip is turned toward furnace. Place top over sides and secure with (4) sheet metal screws per side.

3. Center assembly from left to right on back of furnace with bottom of filter box resting on edge of furnace bottom.

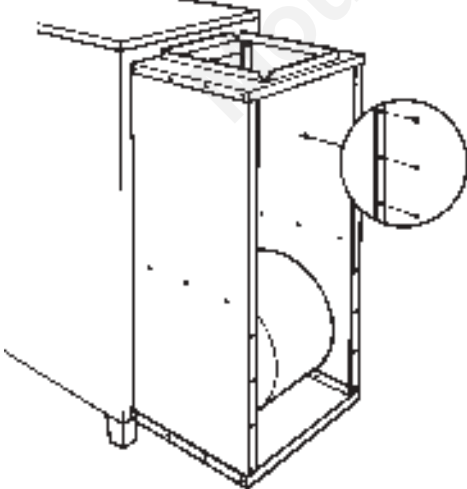

Be sure filter box is perfectly square. Mark position of screw holes on back of furnace. Drill starter holes and secure assembly to back of furnace with self-tapping screws.

NOTE: DO NOT PLACE A SCREW IN THE MIDDLE HOLE

OF EITHER SIDE AT THIS POINT.

4. Attach filter holders to sides of enclosure with sheet metal screws.

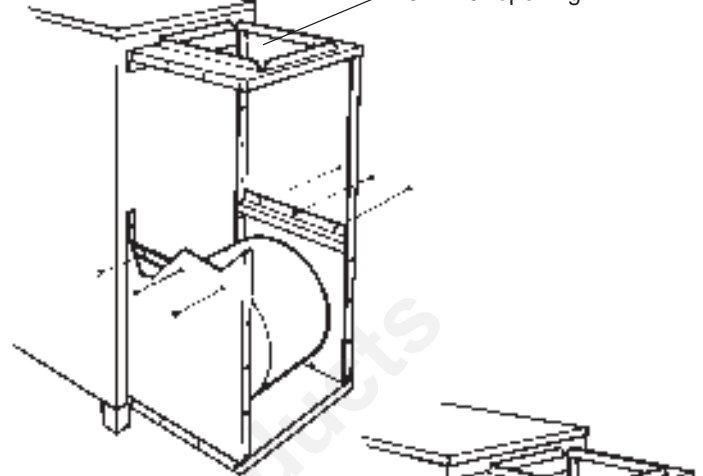

5. Position filter filler between side filter holders and secure to back of furnace with two self-tapping screws.

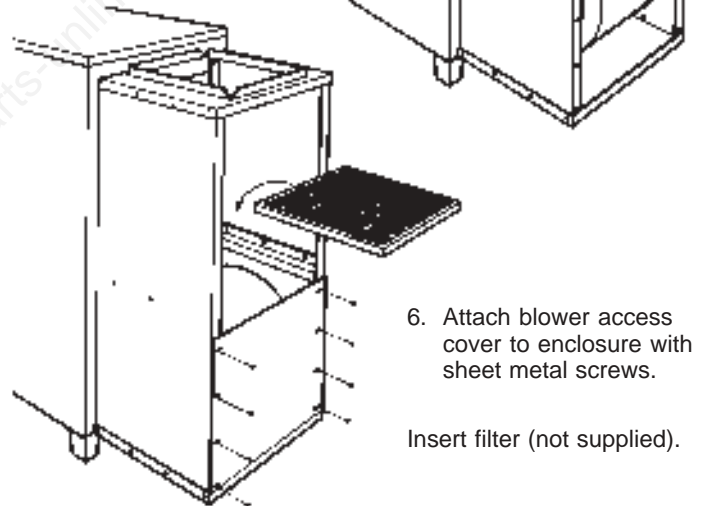

6. Attach blower access cover to enclosure with sheet metal screws.

Insert filter (not supplied).

7. Attach handle to filter cover and slide into position.
8. Connect cold air return duct to top flange of filter box.

NOTE: Drill, punch, or cut access holes as necessary for entrance of power cables, thermostat wire and domestic hot water coil

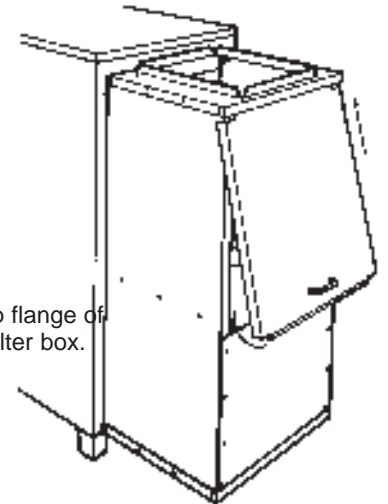

Notes

Mountain View Hearth Products
manuals.stove-parts-unlimited.com

Notes

Mountain View Hearth Products
manuals.stove-parts-unlimited.com

HOW TO ORDER REPAIR PARTS

THIS MANUAL WILL HELP YOU OBTAIN EFFICIENT, DEPENDABLE SERVICE FROM THE HEATER, AND ENABLE YOU TO ORDER REPAIR PARTS CORRECTLY.

KEEP IN A SAFE PLACE FOR FUTURE REFERENCE.

WHEN WRITING, ALWAYS GIVE THE FULL MODEL NUMBER WHICH IS ON THE NAMEPLATE ATTACHED TO THE BACK OF THE HEATER.

WHEN ORDERING REPAIR PARTS, ALWAYS GIVE THE FOLLOWING INFORMATION AS SHOWN IN THIS LIST:

1. The PART NUMBER
2. The PART DESCRIPTION
3. The MODEL NUMBER: 1600 / 1800
4. The SERIAL NUMBER: _____

UNITED STATES STOVE COMPANY

227 Industrial Park Road

P.O. Box 151

South Pittsburg, TN 37380

(423) 837-2100