

SERVICE RECORD

It is recommended that your heating system is serviced regularly and that the appropriate Service Interval Record is completed.

Service Provider:

Before completing the appropriate Service Record below, please ensure you have carried out the service as described in the manufacturer's instructions. Always use the manufacturer's specified spare part when replacement is necessary.

Service 01 Date: _____
 Engineer Name: _____
 License No.: _____
 Company: _____
 Telephone No.: _____
 Stove Inspected: Chimney Swept:
 Items Replaced: _____

Service 02 Date: _____
 Engineer Name: _____
 License No.: _____
 Company: _____
 Telephone No.: _____
 Stove Inspected: Chimney Swept:
 Items Replaced: _____

Service 03 Date: _____
 Engineer Name: _____
 License No.: _____
 Company: _____
 Telephone No.: _____
 Stove Inspected: Chimney Swept:
 Items Replaced: _____

Service 04 Date: _____
 Engineer Name: _____
 License No.: _____
 Company: _____
 Telephone No.: _____
 Stove Inspected: Chimney Swept:
 Items Replaced: _____

Service 05 Date: _____
 Engineer Name: _____
 License No.: _____
 Company: _____
 Telephone No.: _____
 Stove Inspected: Chimney Swept:
 Items Replaced: _____

Service 06 Date: _____
 Engineer Name: _____
 License No.: _____
 Company: _____
 Telephone No.: _____
 Stove Inspected: Chimney Swept:
 Items Replaced: _____

Service 07 Date: _____
 Engineer Name: _____
 License No.: _____
 Company: _____
 Telephone No.: _____
 Stove Inspected: Chimney Swept:
 Items Replaced: _____

Service 08 Date: _____
 Engineer Name: _____
 License No.: _____
 Company: _____
 Telephone No.: _____
 Stove Inspected: Chimney Swept:
 Items Replaced: _____

Note: Register your product on line at www.usstove.com. See "Limited Warranty" section for specific warranty information for your new purchase. Save your receipt with your records for any claims.

OWNERS MANUAL

Models B2350 and B2350B

Wonderlux

THERMOSTAT CONTROLLED COAL CIRCULATOR SERIES

- ASSEMBLY
- INSTALLATION
- OPERATION
- REPAIR PARTS

Conforms To:

UL STD 1482;
 ULC STD S627

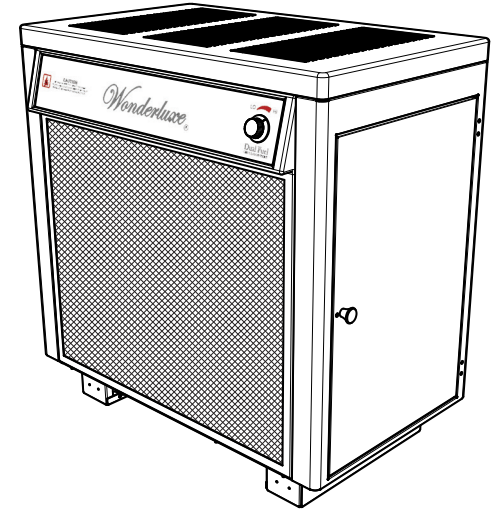

NOTE: This is a coal stove. The use of wood in this stove, other than for coal ignition purposes is prohibited by law.

SAFETY NOTICE:

If this heater is not properly installed, a house fire may result. To reduce the risk of fire, follow the installation instructions. Contact local building or fire officials about permits, restrictions and inspection requirements in your area.

CAUTION:

Please read this entire manual before you install and use your new room heater. Failure to follow instructions may result in property damage, bodily injury, or even death.

DO NOT USE THIS HEATER IN A MOBILE HOME OR TRAILER

United States Stove Company

227 Industrial Park Rd.
 P.O.Box 151
 South Pittsburg, TN 37380
 (423) 837-2100
www.USSTOVE.com



Intertek

851884D-3105F

TOOLS AND MATERIALS NEEDED

TOOLS

- Pencil
- Measuring Tape or 6 foot rule
- Tin Snips
- Drill and 1/8" dia. bit
- Gloves
- Screwdriver (Blade type)
- 5/16" Nut Driver or
5/16" Socket w/Ratchet

MATERIALS

- Chimney Connection- 6" Diameter Black Steel pipe (24 gauge minimum) and elbow(s) either adjustable¹ or corrugated as necessary
 - 1/2" Sheet Metal Screws
 - 6" Inside Diameter Underwriters Laboratories (UL) listed Residential Type and Building Heating Appliance Chimney, Type "HT", or 6" existing Masonry Chimney with flue liner.
 - Floor Protector Material: 3' x 4'-6" (as specified on page 4.)
 - Furnace Cement (Manufacturer recommends: Rutland Code 78 or Equivalent)
- ¹ Avoid adjustable elbows, they leak!

CIRCULATOR DIMENSIONS

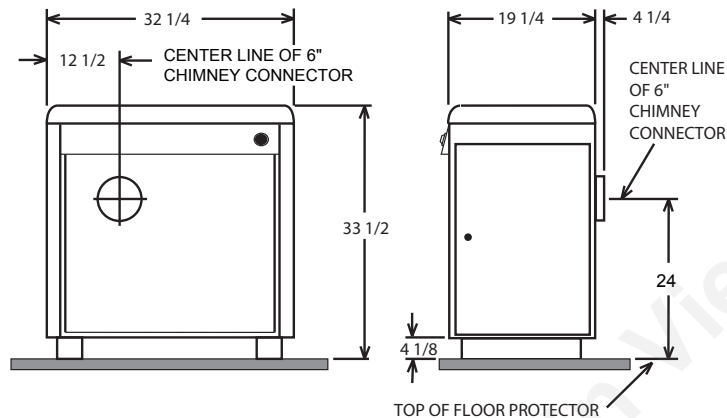

RULES FOR SAFE INSTALLATION AND OPERATION

Save These Instructions! Read these rules and the instructions carefully.

1. Check local codes. The installation must comply with their rulings. Do not install this heater in a mobile home or trailer.
2. Always connect this heater to a chimney or vent to the outside. Never vent to another room or inside a building.
3. Do not connect this heater to an aluminum Type B gas vent. This is not safe and is prohibited by all codes. This heater requires connection to approved chimneys: Either a chimney complying with the requirements for Type HT chimneys in the Standard for Chimneys, Factory Built, Residential Type and Building Heating Appliance, UL 103, or a code approved masonry chimney with a flue liner, preferably round. A larger masonry flue may be used, so long as the flue-section diameter is not greater than 50 sq. in.
4. The chimney portion (whether factor-built or masonry) must be tall enough to provide sufficient draft and safe exit of smoke and combustion products.
5. Be sure that your Chimney is safely constructed and in good repair. Have the chimney inspected by the Fire Department or a qualified inspector (such as a Chimney sweep). Your insurance company may be able to recommend a qualified inspector.
6. Inspect chimney connector and chimney twice monthly during the heating season for any deposit of creosote or soot which must be removed.
7. Provide air for combustion from outside the house into the room where the heater is located. If the intake is not in the same room, air must have free access to the room.

Limited Warranty

The operation of this heater in a manner inconsistent with the owner's manual will void your warranty and is also against federal regulations.

United States Stove Company warrants to the original purchaser its products against premature failure of any component due to workmanship, quality, or materials as follows:

TIME PERIOD:

Firebox	Three Years
Flue Collar	Three Years
All Doors (Feed and Ash Door)	Three Years
Bi-Metal Thermostat	Two Years
Cast Iron, Steel Liners, and Retainers	One Year
Grates	One Year
Door Gaskets	One Year
All Electrical Components (Including Blower) - if equipped	One Year
Cabinet and Trim	One Year

CLAIM PROCEDURE

Any defects should be reported to United States Stove Company or its dealer and/or distributor giving descriptions and pertinent data, including proof of purchase which will be returned upon request.

Providing the heater has been installed and used in accordance with the Owners Manual supplied with the heater, United States Stove Company will either:

- 1) Replace the defective part free of charge
- 2) Replace the heater free of charge
- 3) Where the defect is of a cosmetic (non-functional) nature, United States Stove Company will bear reasonable expense to refurbish the heater, including such items as welding, painting, and incidental labor. A "Reasonable" is defined by terms of this warranty as \$30.00/hour with full refund for any purchase of parts.

NOT COVERED

Specifically not covered under terms of this limited warranty or any other warranty are problems relating to smoking or creosote. Smoking is attributable to inadequate draft due to the design or installation of the flue system or installation of the heater itself. Creosote formation is largely attributable to improper operation of the unit and/or draft as mentioned above. Also, not covered are:

- 1) Removal and re-installation cost.
- 2) Service calls to diagnose trouble (unless authorized in writing by the manufacturer, distributor, or dealer).
- 3) Painted surfaces, brass or brass-colored surfaces.
- 4) Damage or defect caused by improper installation, accidents, misuse, abuse (including overfiring) or alteration.
- 5) Transportation or shipping costs.

LIMITATIONS AND EXCLUSIONS

- 1) United States Stove Company shall not be liable for incidental, consequential, special, or contingent damages anyone might suffer as a result of their breach of this written warranty or any implied warranty.
- 2) Should the heater be replaced by United States Stove Company "free of charge", all further warranty obligations are thereby met.
- 3) Parts and/or service replacements made under the terms of this warranty are warranted only for the remaining period of the original heater warranty.
- 4) Without specific written exclusionary waivers, no one has authority to add to or vary this limited warranty, or to create for United States Stove Company any further obligation of liability in connection with this heater or any other applicable accessory. Any further warranty implication applicable to this heater or any applicable accessory is limited in duration to the same time period as the original statement in the above schedule.

YOUR DUTIES

- 1) This heater, including all applicable accessories, must be installed and operated in accordance with local authorities having jurisdiction and the instructions furnished with the Owners Manual.
- 2) You should keep as permanent record your proof of purchase (or canceled check or invoice).

PROBLEM/RESOLUTION

- 1) As purchaser, you must first contact the dealer and/or distributor from whom you purchased your heater.
- 2) If within a reasonable period of time you do not receive satisfactory service from the distributor and/or dealer, write or call United States Stove Company, Customer Service Department, including complete details of the problem and/or problems you are experiencing, details of your installation, your proof of purchase, and the heater serial number or test agency code number.

WARRANTOR

The warrantor of record is United States Stove Company, PO Box 151, 227 Industrial Drive, South Pittsburg, Tennessee 37380. Phone number: 800-750-2723.

NOTE

This warranty gives you specific legal rights; and, you may also have other rights which vary from state to state.

HOW TO ORDER REPAIR PARTS

This manual will help you to obtain efficient, dependable service from the heater, and enable you to order repair parts correctly.

Keep this manual in a safe place for future reference.

When writing, always give the full model number which is on the nameplate attached to the inside of the cabinet door of the heater.

When ordering repair parts or options, always give the following information as shown in this list:

1. The **PART NUMBER**
2. The **PART DESCRIPTION**
3. The **MODEL NUMBER:** _____
4. The **SERIAL NUMBER:** _____

Before installing your heater, fill in the serial number of your heater in the space provided above.

United States Stove Company

227 Industrial Park Rd.
P.O.Box 151
South Pittsburg, TN 37380
(423) 837-2100
www.USSTOVE.com

8. **CAST IRON PARTS MUST BE "SEASONED" TO AVOID CRACKING. BUILD ONLY SMALL FIRES ON FIRST USE.**
9. To prevent injury, do not allow anyone to use this heater who is unfamiliar with the correct operation of the heater. Do not allow children to use or in any way operate this heater.

CAUTION: DO NOT TOUCH THE HEATER UNTIL IT HAS COOLED. ALWAYS WEAR GLOVES WHEN REFUELING THIS UNIT OR WORKING WITH METAL CABINET PARTS.

10. Keep the ash pit section free of excess ashes. Do not allow ashes to stack higher than the sides of the ash pan. Never allow the ashes to contact the grate.
11. **CAUTION:** The special paints used on your heater may give off some smoke while they are curing during first few fires. Build small fires at first. The metal used in construction of the heater has a light coating of oil. This could give off smoke and/or odors when heater is used for the first couple of times. This should disappear after a short period. Once this burn-off has occurred, it should not reoccur.
12. **CARING FOR PAINTED PARTS-** This heater has a painted outside jacket, which is durable but will not stand rough handling or abuse. When installing your heater, use care in handling. Clean with soap and warm water

MINIMUM CLEARANCES TO COMBUSTIBLE WALLS AND CEILINGS

Minimum clearances to unprotected combustible walls and ceilings as noted by figures 2 through 4 must be maintained. Drapes, curtains, furniture and other combustible materials should be kept much further away from the heater to avoid fire. If you choose to, you may install the heater and chimney connector closer to combustible surfaces than indicated by Figures 2 through 4 if a clearance reduction system is also installed to protect combustible ceilings and walls near the heater and chimney connector. However, there are limits to how close the heater and chimney connector can be installed to combustible surfaces protected by a clearance reduction system.

A correctly installed clearance reduction system protects the combustible surfaces well beyond the sides and above the top of the heater and beyond the sides and top of the chimney connector pipe.

Two common types of clearance reduction systems use sheet metal with a minimum thickness of 28 gauge (galvanized steel, aluminum, copper) or a 3-1/2 inch (4 inch nominal) thick masonry wall. Either of these materials must be spaced out 1 inch from the combustible surfaces. With sheet metal, non-combustible spacers are used to maintain the 1 inch air space. With a masonry wall, metal wall ties and furring strips, if needed are used to anchor the brick to the wall.

when heater is not hot. **DO NOT** use any harsh chemicals (acids or caustics) or scouring powder, as these wear and dull the finish.

13. **KEEP THE FEED DOOR, ASH DOOR AND CABINET DOOR CLOSED AT ALL TIMES EXCEPT WHILE TENDING THE HEATER. KEEP SEALS IN GOOD CONDITION. DO NOT OVERFIRE THE HEATER. THIS WILL HAPPEN IF THE FEED DOOR, OR PARTICULARLY THE ASH DOOR, IS LEFT OPEN DURING OPERATION. UNDER EXTREME CONDITIONS THIS CAN PRODUCE DANGEROUS RESULTS. AT A MINIMUM, IT WILL ALLOW THE PAINT TO DISCOLOR.**
14. **DO NOT USE** the coal bricks that are manufactured from coal dust and a wax-type binder.
15. Use smoke detectors in the room where your heater is installed. We recommend installing smoke detectors in your home if not already installed.
16. **DO NOT** connect this heater to any air distribution duct or system.
17. Never use make-shift compromises during the installation.
18. For further information on using your heater safely, obtain a copy of the National Fire Protection Association (NFPA) publication "Using Coal and Wood Stoves Safely" NFPA No. HS-10-1978. The address of the NFPA is Battery March Park, Quincy, MA. 02269.

To avoid excessive heat transmission, the spacers or wall ties should not be placed directly behind the heater or chimney connector. The 1 inch air space provides free air circulation. It is essential that there be openings at the top and bottom of these clearance reducers so cool air can enter at the bottom and hot air exit at the top. It is the "chimney effect" whereby when the air in the space is heated, it rises exiting from the top and being replaced by cooler air at the bottom, that makes these shields effective.

Masonry, or other non-combustible products, attached directly to a combustible surface without an air space offer very little protection and cannot be considered a clearance reducer unless specified materials have been tested and listed for direct attachment to a combustible surface. The same applies to thin veneer brick and stone coverings. These materials provide adequate protection only when mounted on sheet metal with a 1 inch spacing to the wall.

A variety of prefabricated clearance reduction systems which have been tested and listed are available through heater dealers. Always look for a safety listing label on the product when selecting a clearance reduction system and make sure it is designed for solid fuel appliances. The manufactures of these systems provide specific installation instructions that must be followed exactly for a safe installation.

LOCATING THE HEATER

AS A LOCATION IS SELECTED, KEEP THE FOLLOWING MIND:

1. The chimney connection should be as airtight as possible. The heater must have its own chimney flue. Do not connect this unit to a chimney flue serving another appliance. If there is no chimney near where you wish to place the heater, you can use a UL 103HT Residential Type and Building Heating Appliance Chimney.
2. Place the heater on solid masonry or solid concrete. When the heater is used on a combustible floor, use a non-combustible floor protector of one layer of 3/8" millboard having a thermal conductivity of K=0.84 BTU in./ft. 2 hr. Deg. F with 28-gauge sheet metal or a UL 1618 Listed floor protector with 0.45 R-Value. Have the floor protector extend 16" beyond the door side of the heater and under the connector pipe in the back.
3. Check Figures 2, 3, and 4. Be sure you have the clearances shown from the heater and the connector pipe to combustible surfaces. If you have a solid brick or stone wall behind your heater, you can place the heater as close as you wish to the wall. If the wall is only faced with brick or stone, treat it as a combustible wall.

NOTES

NOTE: BEFORE FIRING HEATER

Slide firebricks toward the rear so no gaps remain between them.

CAUTION:

Keep furnishings and other combustible materials away from the heater.

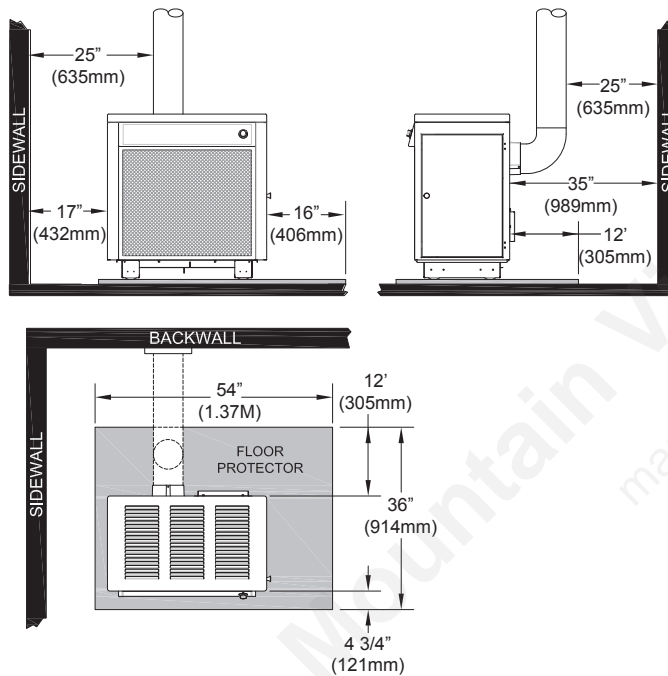

NOTICE:

Clearances stated above may ONLY be reduced by means approved by the regulatory authority.

DO NOT CONNECT TO OR USE IN CONJUNCTION WITH ANY AIR DISTRIBUTION DUCT OR SYSTEM.

EXTERNAL PARTS DIAGRAM/LIST

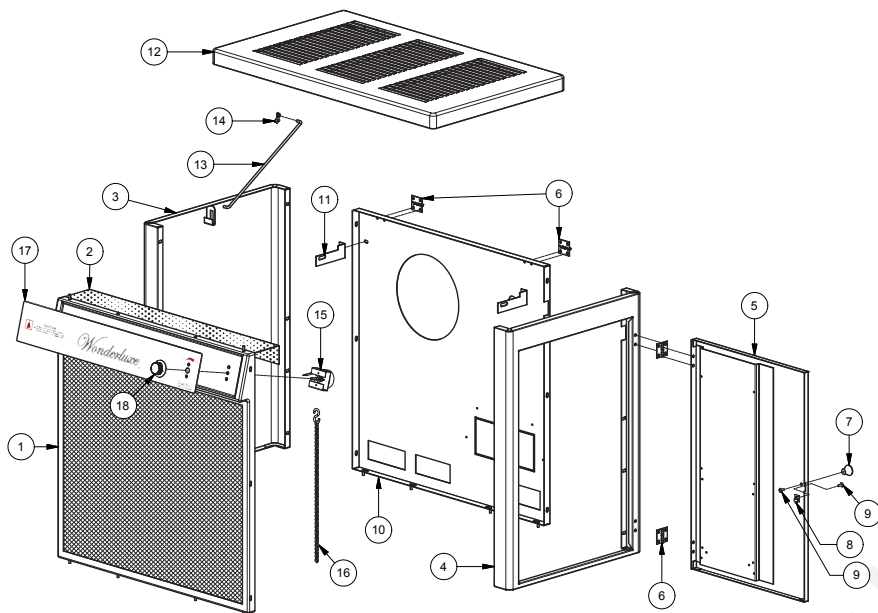

Key	Part No.	Description	Qty.
1	67725P	Panel, Cabinet Front - Pewter	1
2	23477	Shield, Top Thermo	1
3	67967B	Cabinet, Left	1
4	67968B	Frame, Door	1
5	67969B	Door, Cabinet	1
6	89065	Hinge, Door	4
7	89635	Knob, Door	1
8	83093	Latch, Spring	1
9	83005	#10-24 x 1/2 Machine Screw, PH HD	2
10	69557B	Back, Cabinet	1
11	21063	Brace, Back	2
12	67966B	Top, Cabinet	1
13	21593	Support, Hinge	1
14	83833	Clip, Hinge	1
15	67743	Assy., Thermostat	1
16	69271	Chain & Hook Assembly	1
17	851886	Plate, Control Panel - Wonderluxe	1
18	89687	Knob, Thermostat	1

CHIMNEY CONNECTION

Two basic types of chimneys are approved for use with solid fuel: Factory-built and masonry. Factory-built chimney must comply with UL 103 type "HT" standard.

Do not expect your stove or furnace to create draft. Draft is not a function of the appliance. It is purely a function of the chimney. Modern stoves and furnaces are much more air-tight and efficient than those of the past and, therefore require greater draft. A **minimum of .05 w.c. (12.45Pa)**, is required for proper drafting to prevent back-puffing, smoke spillage, and to maximize performance. Gauges to measure chimney draft are readily available at stove shops and are economical to purchase or rent.

Chimneys perform two functions - one of which is apparent: The chimney provides a means for exhausting smoke and flue gases resulting from combustion of the fuel. Secondly, though, the chimney provides "Draft" which allows oxygen to be continuously introduced into the appliance, so that proper combustion is possible.

IMPORTANT

Your chimney connector and chimney must have the same diameter as the stove outlet (6"). If this is not the case, we recommend you contact your dealer in order to insure there will be no problem with the draft.

The stove pipe must be made of aluminized or cold roll steel with a minimum thickness of 0.021" or 0.53 mm. It is strictly forbidden to use galvanized steel.

Your smoke pipe should be assembled in such a way that the male section (crimped end) of the pipe faces down. This will allow condensation in the flue to run back into the heater. Attach each of the sections to one another with three equidistant metal screws and seal each joint with furnace cement.

The pipe must be short and straight. All sections installed horizontally must slope at least 1/4 inch per foot, with the upper end of the section toward the chimney.

To insure a good draft, the total length of the coupling pipe should never exceed 8' to 10' (2.4m to 3.04 m). (Except for cases of vertical installation, cathedral-roof style where the smoke exhaust system can be much longer and connected without problem to the chimney at the ceiling of the room).

It is recommended that no more than two 90 degree bends be used because it may reduce the amount of natural draft. The use of corrugated (non-adjustable) elbows is preferred as they are much more airtight.

You must have at least 18 inches of clearance between any horizontal piping and the ceiling.

The pipe cannot extend into the chimney flue.

The chimney connector must not pass through an attic, roof space, closet, any concealed space, floor, ceiling, wall or combustible construction. Where passage through a wall or partition of combustible construction, the installation must conform to CAN/CSA-B365, Installation Code for Solid-Fuel-Burning Appliances & Equipment.

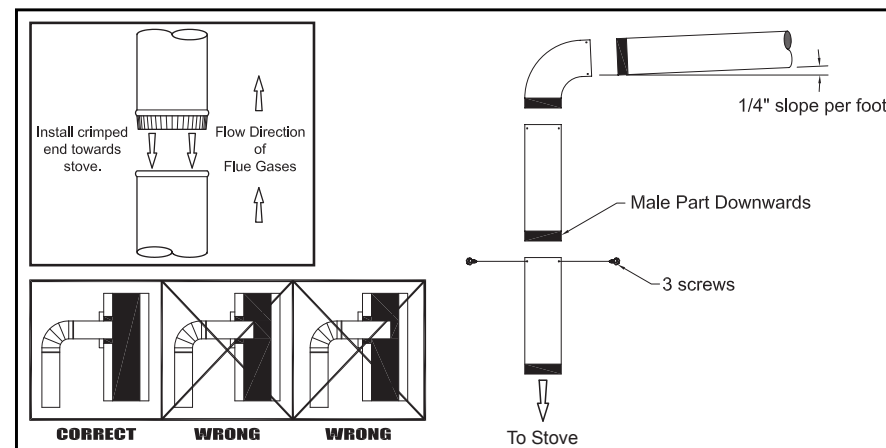

CHIMNEY

Your stove may be hooked up with a 6" factory built or masonry chimney. If you are using a factory built chimney, it must comply with UL 103 standard; therefore it must be a Type HT (2100°F). It is extremely important that it be installed according to the manufacturer's specifications.

If you are using a masonry chimney, it is important that it be built in compliance with the specifications of the National Building Code. It must be lined with fire clay bricks, metal or clay tiles sealed together with fire cement. (Round flues are the most efficient).

The interior diameter of the chimney flue must be identical to the stove smoke exhaust. A flue which is too small may cause draft problems, while a large flue favours rapid cooling of the gas, and hence the build-up of creosote and the risk of chimney fires. Note that it is the chimney and not the stove which creates the draft effect; your stove's performance is directly dependent on an adequate draft from your chimney.

DO NOT CONNECT THIS UNIT TO A CHIMNEY FLUE SERVING ANOTHER APPLIANCE.

The following recommendations may be useful for the installation of your chimney:

1. It must rise above the roof at least 3' (0.9m) from the uppermost point of contact.
2. The chimney must exceed any part of the building or other obstruction within a 10' (3.04m) distance by a height of 2' (0.6m).
3. Installation of an interior chimney is always preferable to an exterior chimney. Indeed, the interior chimney will, by definition, be hotter than an exterior chimney, being heated up by the ambient air in the house. Therefore the gas which circulates will cool more slowly, thus reducing the build-up of creosote and the risk of chimney fires.
4. The draft caused by the tendency for hot air to rise will be increased with an interior chimney.
5. Using a fire screen at the extremity of the chimney requires regular inspection in order to insure that it is not obstructed thus blocking the draft, and it should be cleaned when used regularly.

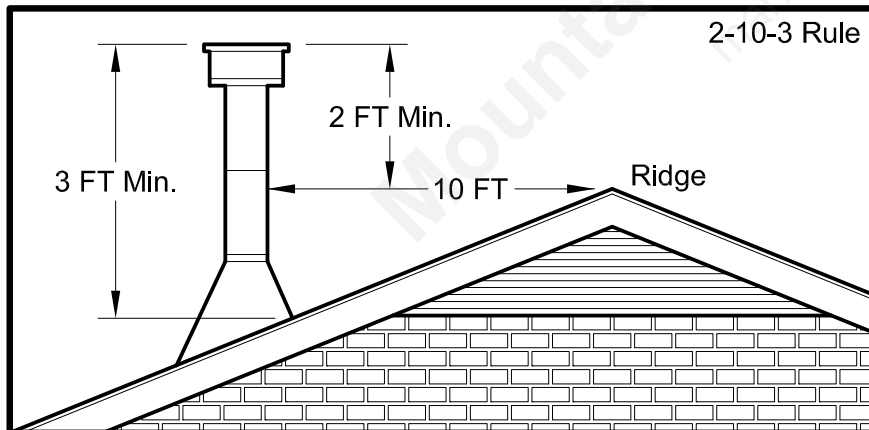

PARTS LIST

Key	Part No.	Description	Qty.
1	67859	Weldment, Base	1
2	22030	Shield, Second Heat (Included w/ 67859)	1
3	22110	Shield, Heat (Included w/ 67859)	1
4	69657	Assy., Heat Jacket	1
5	88032	Gasket, Flue Collar	1
6	40246	Collar, Flue	1
7	22090	Curtain, Smoke	1
8	22171	Clip, Smoke Curtain	2
9	40075	Frame, Draft Damper	1
10	67132	Damper, Draft Control	1
11	25550	Pin, Draft Damper	1
12	83890	Clip, Push	1
13	40100	Liner, Front/Back	3
14	22536	Support, Grate	2
15	40102	Grate, Frame	1
16	40101	Grate, Coal	1
17	40045	Shaker	1
18	40132	Retainer, Brick	2
19	89066	Firebrick (4.5" x 9" x 1.25")	10
20	891940	Assy., Feed Door (Complete)	1
-	40199	Feed Door - Casting Only	-
21	88033	Rope Gasket, 3/8"	3.75 ft.
22	891941	Assy., Ash Door (Complete)	1
-	40289	Ash Door - Casting Only	-
23	88033	Rope Gasket, 3/8"	2.42 ft.
24	83872	Pin, Door - Short	1
25	23441	Pin, Door - Long	1
26	83102	Bolt, 1/4-20 x 1.25" CS, Slotted Hd.	2
27	40056	Wheel, Draft	2
28	83415	Nut, 1/4-20 Jam	2
29	25201	Shield, Flame	2
30	83250	Kep Nut, 1/4-20	4
31	40509	Handle, Door	2
32	89523	Handle, Drop Wood	1
33	22434	Latch, Door (2-Step)	1
34	83045	Washer, Flat	2
35	83273	Washer, Spacer	1
36	22108	Latch, Door (Door Stop)	1
37	23474	Liner, Top	1
38	67444	Ash Pan	1

INTERNAL PARTS DIAGRAM

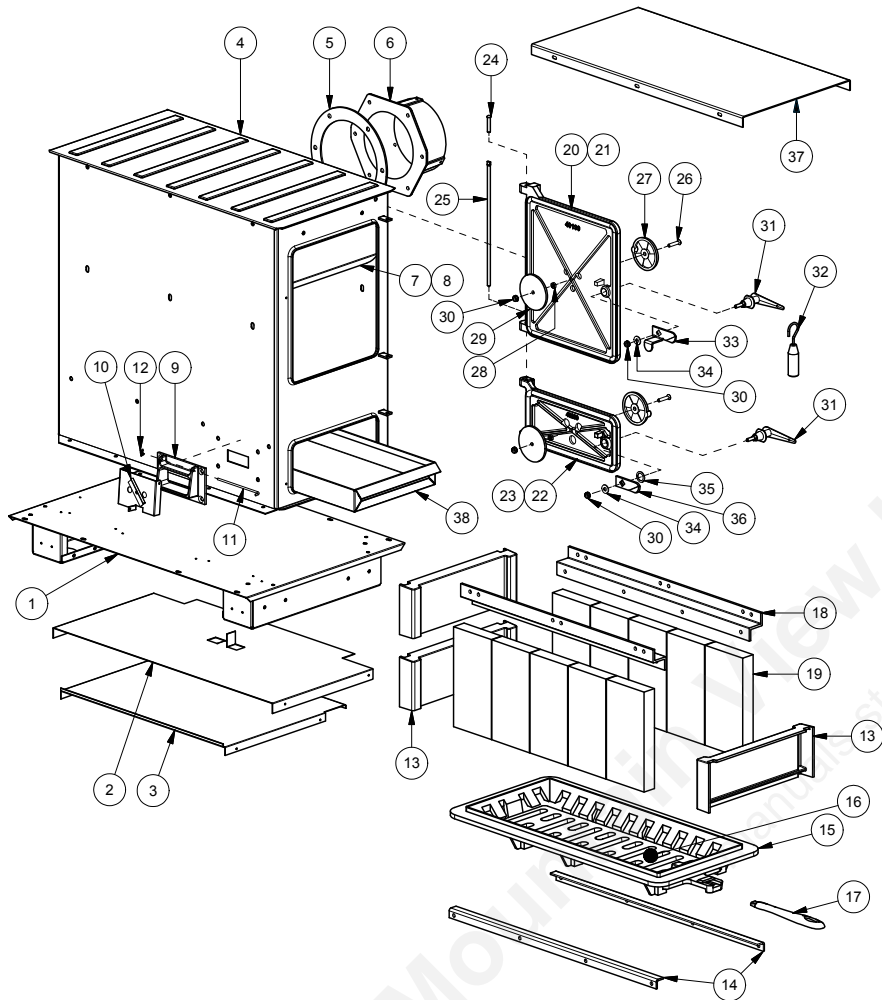

IN ORDER TO MAINTAIN WARRANTY, COMPONENTS MUST BE REPLACED USING ORIGINAL MANUFACTURERS PARTS PURCHASED THROUGH YOUR DEALER OR DIRECTLY FROM THE APPLIANCE MANUFACTURER. USE OF THIRD PARTY COMPONENTS WILL VOID THE WARRANTY.

FACTORY BUILT CHIMNEY

When a metal prefabricated chimney is used, the manufacturer's installation instructions must be followed. You must also purchase (from the same manufacturer) and install the ceiling support package or wall pass-through and "T" section package, firestops (where needed),

insulation shield, roof flashing, chimney cap, etc. Maintain proper clearance to the structure as recommended by the manufacturer. The chimney must be the required height above the roof or other obstructions for safety and proper draft operation.

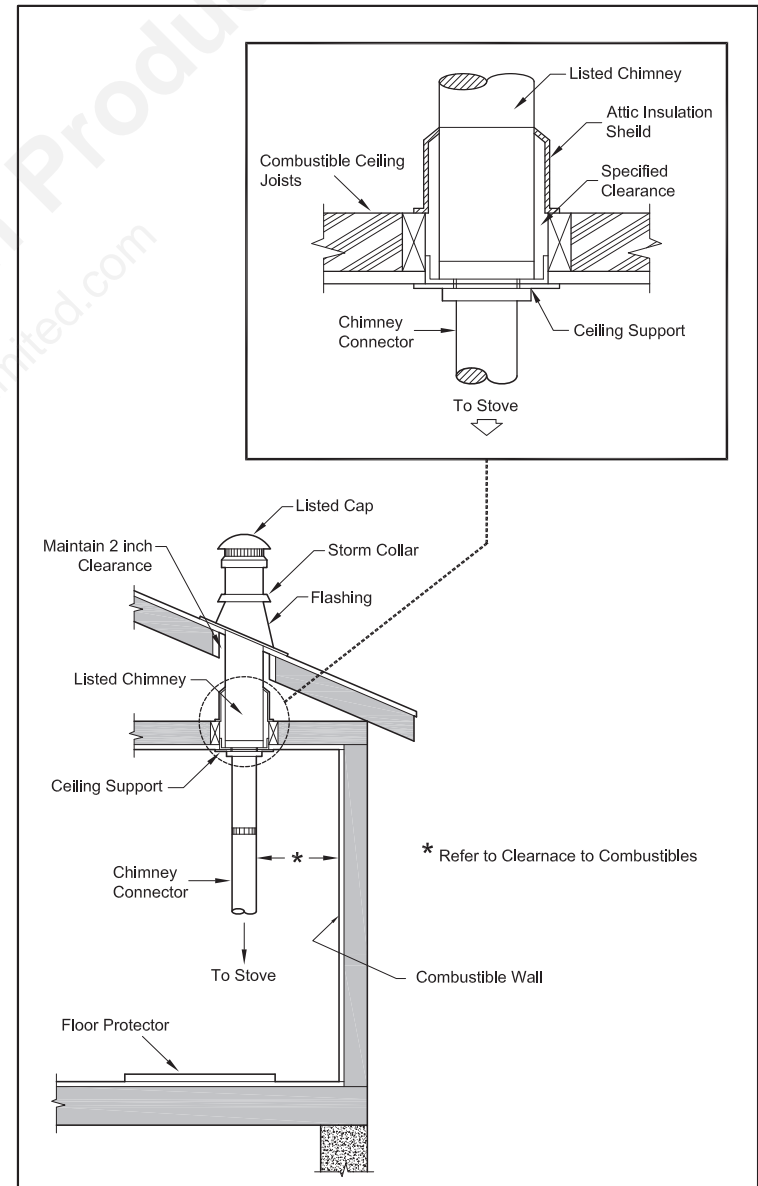

VENTING INTO A FIREPLACE

Many people may wish to convert an existing fireplace to heater use. Usually, safe connection of stovepipe to a masonry chimney requires more effort than connection to a prefabricated chimney. The fireplace must be closed and sealed at the damper in the flue. Good sealants are high temperature caulking, ceramic wool, and furnace cement. Always remember to inspect the masonry chimney and fireplace. If necessary, clean the flue and smoke shelf before beginning your installation. Install the heater into the chimney so that the system can be dismantled for cleaning and inspection.

Before deciding to convert your fireplace or existing chimney, keep in mind that older fireplaces and their chimneys are unsafe. They must be structurally sound, and the flue liner must be in good condition. **Do not use a chimney if it is unlined (should have a fire clay liner to protect brickwork), have it relined professionally.** Clearances to combustibles are explained in the previous section on masonry chimneys. If you have any questions regarding the condition of the chimney, consult a qualified engineer, competent mason, certified Chimney Sweep, or knowledgeable inspector.

Many prefabricated fireplaces fall into the "zero-clearance fireplace" category. This is a factory metal fireplace with multi-layered construction. It is designed to provide enough insulation and/or air cooling so that the base, back and sides can be safely placed in close contact with combustible floors and walls. Although many prefabricated fireplaces have been tested by nationally recognized organizations for use as fireplaces, they have not been tested to accept heaters. In fact, their use as such may void the manufacturer's warranty.

Steel-lined fireplaces, on the other hand, can be used with heaters. These units use a 1/4-inch fire box liner and an air chamber in connection with 8 inches of masonry to meet code. They contain all the essential parts of a fireplace, firebox, damper, throat, smoke shelf, and smoke chamber. Many of them look exactly like a masonry fireplace and must be checked closely for above requirements before installing a coal heater into them.

Another method frequently used by some people is to vent the heater directly into the fireplace. This does not meet code since the

heater is being vented into another appliance - the fireplace. This method should not be attempted because combustion products will deposit and build up in the firebox or fireplace. Be certain not to install a hazard in your house. **You will void your warranty with this installation.**

Connection of the stovepipe directly into the existing masonry chimney over the fireplace opening is the only approved method. This installation performs better, yielding easy to clean and inspect for creosote. Before beginning this type of installation plan carefully; a high degree of skill is required to insure safety.

An entry port for the stovepipe must be cut through the chimney with minimum damage to the fire clay liner. Some involved measurements may be required to locate the flue liner exactly. Before cutting, take time to mark the size and position of the entry port. Position the entry port so that at least 8 inches of the flue liner remains below the port.

Keep in mind that wood mantels and combustible trim around the fireplace must have adequate clearances from the heater and stovepipe or must be protected in an approved manner. Also, be sure to leave at least 24" clearance between the top of the stovepipe and the combustible ceiling or other combustibles. Placing the center of the entry port 2 feet below the ceiling will insure proper clearance for 6 inch, 8 inch, and 10 inch stovepipes. Next, install a fire clay (at least 5/8 in. thick) or metal thimble, being sure that the thimble is flush with the inner flue lining. Secure the thimble in place with refractory mortar. The thimble should be surrounded on all sides with 8 inches of brickwork (solid masonry units) or 24 inches of stone.

Install the stovepipe as far as possible into the thimble, but not past the inside of the flue lining. There should be a small air space (approximately 1/2 in.) between the stovepipe and thimble, allowing for expansion of the stovepipe. Seal this airspace with high-temperature caulking or ceramic wool. Finally, be sure to wire the damper closed and apply the same sealant you used at the stovepipe and thimble junction.

Do not vent up through the fireplace opening, regardless of whether the fireplace opening is closed.

MAINTENANCE

DISPOSAL of ASHES

Ashes should be removed from the stove every few days or when ashes get to 2 to 3 inches deep. Always empty the stove when it is cold, such as in the morning. Ashes should be placed in a metal container with a tight fitting lid. The closed container of ashes should be placed on a non combustible floor or on the ground, well away from all combustible materials, pending final disposal. If the ashes are disposed of by burial in soil or otherwise locally dispersed, they should be retained in the close container until all cinders have thoroughly cooled. Do not use the ash container to dispose of other trash.

CREOSOTE / SOOT - FORMATION AND NEED FOR REMOVAL

When coal is burned slowly, it produces tar and other organic vapors, which combine with expelled moisture to form creosote or soot. The creosote vapors condense in the relatively cool chimney flue of a slow-burning fire. As a result, creosote/soot residue accumulates on the flue lining. When ignited this creosote/soot makes an extremely hot fire. When burning coal, the chimney connector and chimney should be inspected at least twice a month during the heating season to determine if a creosote/soot build-up has occurred. If creosote/soot has accumulated, it should be removed to reduce the risk of a chimney fire.

If a chimney or creosote fire occurs, close all dampers immediately and call the fire department.

Once a chimney fire occurs, it can only be extinguished by removing its source of oxygen. This can be accomplished by shutting any mechanical draft devices and/or discharging a CO² (Carbon Dioxide) or Halon fire extinguisher directly into the heater through an appropriately placed cleanout. If using a Halon extinguisher, please note that it totally displaces oxygen and could become a hazard in itself if enough is discharged into the living space.

CAUTION:

- ASHES COULD CONTAIN HOT EMBERS EVEN AFTER TWO DAYS WITHOUT OPERATING THE STOVE.
- THE ASH PAN CAN BECOME VERY HOT. WEAR GLOVES TO PREVENT INJURY.
- NEVER BURN THE STOVE WITH THE ASH DOOR OPEN. THIS WOULD RESULT IN OVER FIRING THE STOVE. DAMAGE TO THE STOVE AND EVEN A HOUSE FIRE MAY RESULT.

Wait for the heater to cool, then inspect the chimney area for damage. A chimney fire may cause ignition of wall studs or rafters which you thought were at a safe distance from the chimney. If no damage results, perform a chimney cleaning to ensure there is no more creosote deposits remaining in the chimney. We suggest having your chimney inspected by a qualified person before using again.

Establish a routine technique for seasoning, storing, and burning your fuel. Check daily for creosote build-up until experience shows how often you need to clean to be safe. Be aware that the hotter the fire, the less creosote or soot is deposited and weekly cleaning may be necessary in mild weather even though monthly cleaning may be enough during the colder months. Contact your local municipal or provincial fire authority for information on how to handle a chimney fire if one occurs. Have a clearly understood plan to handle the situation if such an event were to happen.

NOTICE:

KEEP YOUR CHIMNEY CONNECTOR AND CHIMNEY CLEAN AND IN GOOD CONDITION. DOING SO CAN MAINTAIN HEATER EFFICIENCY AND REDUCE THE RISK OF A FIRE.

to a near closed position - but leave the ash pit damper at least partially open to prevent the fire from going out. Adjust the stove pipe damper to reduce the draft on the fire. With anthracite there will be short blue flames above the coal, except when the fire is started or a new charge is added. If, however, there is no flame then the fire needs more air from the bottom (unless it is near the end of its burn cycle and needs to be recharged).

Only when the coal is burned down to half its original depth it is time to add fresh coal. When doing so, open the stove pipe damper and turn the thermostat damper to high, which will allow the fire to burn off any accumulated gases. Open the feed door, and with a small rake, hoe, or hooked poker pull the glowing coals to the front of the firebox. Try not to disturb the fire too much. Next, add a fresh charge to the back being careful not to seal off the top. Close the feed door, but leave the spin damper (or thermostat) open for a few minutes until the volatile gases have burned off. It is not necessary to shake down the ashes each time you refuel the furnace. Experience will be your best teacher.

DR6 - 6" DRAFT REGULATOR - OPTIONAL KIT

In the unlikely event that your heater "overfires" (a condition evidenced by elbows, stove pipes, and connectors glowing red in appearance or otherwise discoloring), then your installation is subject to excessive draft created by either a chimney too tall or too great in diameter in conjunction with its height, or some other factor of an indeterminate cause. In this event, you should install a barometric draft regulator. Such installation will preclude any over-firing and/or any hazardous consequences of potential overfiring.

Barometric draft regulators are generally available where you purchased your stove or may be ordered directly from United States Stove Company at a nominal charge.

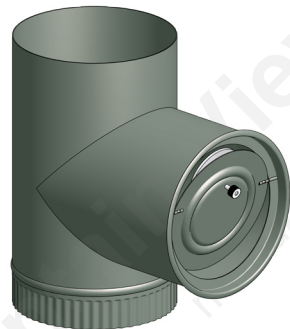

B36TK - THERMODISC KIT FOR B36 BLOWER - OPTIONAL

Wish your blower would turn ON and OFF as the heater gets warm and cold? It can with this optional kit from U.S. Stove. It connects in line with your power supply cord and mounts to the back of the heater. When the snap disc reaches 120 degrees, the blower automatically turns ON and turns itself OFF if it reaches 90 degrees. See your Dealer for details or call U.S. Stove directly.

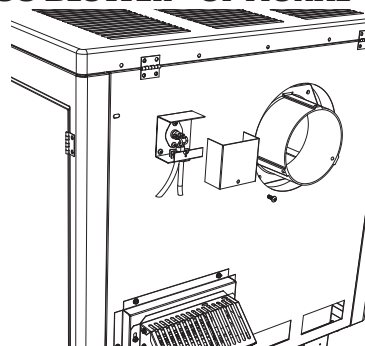

BANKING THE FIRE:

For extended operation, such as overnight, the fire will need to be banked. To do so heap coal up along the sides and back of the firebox so that the fire gradually burns it over a longer period of time. The intensity of the fire will also be reduced without letting it go out. Follow the same procedure as for refueling. If possible, avoid shaking, as a heavier layer of ash will help reduce the intensity of the fire during this time. After loading, let the fire establish itself for about 30 minutes. Then close your damper and automatic control to the point where the house does not become too cold. It is important that you begin banking early enough before retiring or leaving that you can make necessary adjustments after the fire is well established.

To revive a coal fire that is almost out, (1) open the ash door and stove pipe damper and close the spin damper under the door to get a good draft through the grate. (2) place a thin layer of dry coal over the entire top of the fire. **DO NOT POKE OR SHAKE THE FIRE AT THIS TIME!** (3) after the fresh coal has become well ignited shake the grate (just a little), refuel.

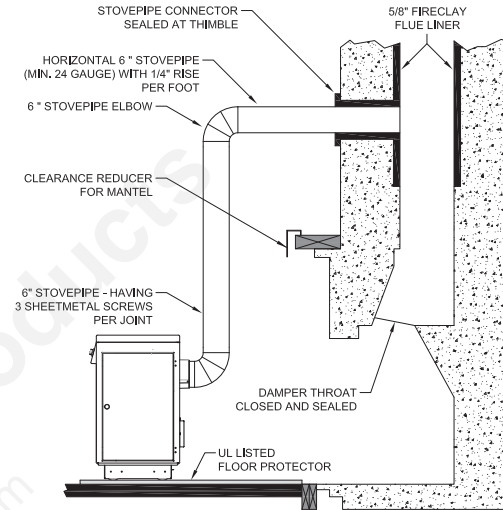

MASONRY CHIMNEY

Masonry Chimneys have several positive attributes: If properly built, they are quite durable, and most homeowners consider them more attractive perhaps than a non-enclosed factory built chimney. And, if the chimney is located within the confines of the house (that is, not attached to an exterior wall), its mass alone will store heat longer and continue to release the heat long after the fire has died. Masonry chimneys have many disadvantages though.

Masonry chimneys constructed on an exterior wall are exposed to cold outdoor temperatures, promoting greater heater loss, higher accumulations of creosote, and reduced draft which leads to poorer heater or furnace performance.

When considering a masonry chimney, round tiles are preferable to square or rectangular, as round tiles have much better airflow characteristics and are far easier to clean. Unfortunately, most North American chimneys use square or rectangular tile liners that are really designed for open fireplaces, not stoves or furnaces. Of most importance, second only to overall chimney height, is the diameter of the flue liner itself. In most instances, it should be sized to the appliance; i.e., 6" flue outlet on the appliance requires a 6" flue. The inner diameter should never be less than the flue outlet diameter and should never be greater than 50% of the appliance

flue outlet. For example, do not expect a burning stove or furnace to function properly if installed into a chimney with a flue liner greater than 50% the appliance outlet -- such as a 6" flue outlet requires a 6" diameter for optimum drafting, but can function well with an 8", but becomes borderline beyond 8" diameter.

Masonry chimneys built of concrete blocks without flue liners of at least 5/8" fireclay do not meet modern building codes. A solid fuel appliance must not be joined to a chimney flue which is connected to another appliance burning other fuels.

If your chimney has a typically oversized flue liner of 8x12 inches or greater, or if it is unlined, it will be necessary for you to reline the chimney, using many of the modern approved and economical methods such as stainless steel, castable refractory, or properly sized fireclay linings.

If you have any question regarding venting your appliance, feel free to contact the factory at the address and phone number on this Owner's Manual. You may also contact NFPA (National Fire Protection Association) and request NFPA Standard 211 (1984 Edition). Their address is Battery March Park, Quincy, Massachusetts 02269. Another helpful publication is NFPA Standard 908, available at the same address. Specify 1984 Edition on either of the above publications.

MASONRY CHIMNEY continued...

Ensure that a masonry chimney meets the minimum standards of the National Fire Protection Association (NFPA) by having it inspected by a professional. Make sure there are no cracks, loose mortar or other signs of deterioration

and blockage. Have the chimney cleaned before the stove is installed and operated. When connecting the stove through a combustible wall to a masonry chimney, special methods are needed.

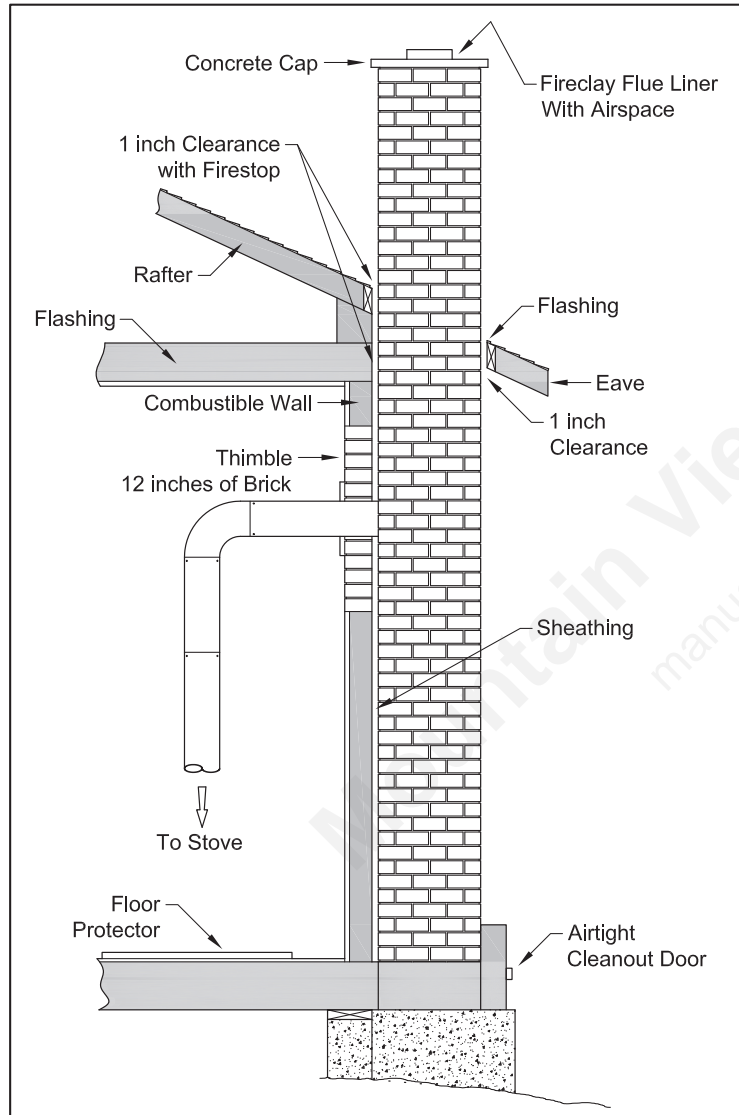

10

BULLETINE RC454

A guide to burning coal in your heater.

Heaters that are capable of burning coal usually will burn both Bituminous and Anthracite coal. Anthracite is perhaps the best coal fuel because of its long even burn time, high heat output, and cleanliness which make it a good choice for the home. However, keep in mind it is a much more difficult fuel to use, requires more care and patience, is not so widely available, and is usually much more expensive than Bituminous

SIZE OF COAL:

Most sizes of Bituminous Coal will work in a coal heater; for best results we recommend large "nut" coal to small "egg" coal (1-3/4" diameter to 4" diameter). When burning Anthracite, use "egg" or "broken" with sizes between 2-5/16" thru 4-3/8". Note that it is important to the long life of your stove to buy coal which has been sized and cleaned. Cleaning insures removal of rocks and other minerals. Never use coal smaller than 1" or larger than 5" in diameter. Small sized coal will smother the fire. Too large a size of coal will not burn well.

STOVE OPERATION:

All coal fires should be started with wood which will allow the fire to get hot enough to ignite the coal. The best ignition fires utilize dry pine or other resinous soft woods as kindling, with hard wood (oak, hickory, ash) added to increase the heat prior to addition of the coal.

Before starting the fire, open the stove pipe damper (if equipped), turn the thermostat to high, open the ash pit door and feed door, place newspaper and finely split kindling on the grate, light the paper, add larger hard wood after the kindling is burning brightly. CAUTION: Never use gasoline, lantern fuel, kerosene, charcoal lighter fluid, or other flammable liquids to start or freshen up a fire in any heater. Place the larger pieces of wood on the fire so that they are slightly separated and form a level for the addition of coal. It will take 10 to 20 minutes before this wood is thoroughly ignited. Adding coal too soon will cut the air supply and smother the fire.

BURNING BITUMINOUS:

Once your kindling and wood fire has produced a bed of well established coals, start adding coal in layers allowing each to ignite before adding more. Bituminous has a high volatile content and, as a result, should be fired with the "conical method" - with the highest portion of your fire bed in the center of the firebox. The first flames will be long and generally orange or yellow and produce quite a bit of smoke. As the gases burn off the flames become shorter, change color and produce less smoke.

Once the fire is WELL ESTABLISHED add coal

to the center of the firebox forming the cone. Burning in this fashion allows heat to drive off the volatile gases, and turbulence created increases the burn efficiency. There will have to be some experimenting with the individual setup as no two chimney's or installations are going to be the same. Just remember to allow enough air to enter the firebox and keep the stove pipe damper open so that volatiles are properly burned. Before refueling, take the time to break up the cone a little with a poker, especially if it has caked over or formed a crust. But, be careful not to mix the coal as this increases the chances of forming clinkers. When shaking the grate(s) be gentle. Just a few short movements - a couple of "cranks" - is better than a lot of agitation. The objective is to remove a small amount of the ashes without disturbing the fire. Stop when you see a glow in the ashes or the first red coals fall into the ash pan. Excessive shaking wastes fuel and can expose the grate(s) to very high temperatures which can cause warping or burnout.

For overnight operation (long duration burn time) shake the fire and add coal, retaining the center cone. Once the volatile are burned off, close the feed door and adjust the stove pipe damper, if equipped. Then adjust the thermostat to the desired heat level.

More MAINTENANCE will be needed with bituminous coal than with anthracite coal as more soot will collect on heating surfaces and in pipes, requiring more frequent cleaning.

ANTHRACITE:

Add a thin layer of coal (preferably smaller chunks) to the wood fire, being careful not to disturb it too much or cut off the draft. Then, add a second heavier layer after the coal is ignited and burning well. If necessary, add a third layer to bring the coal up to the top of the front liner (not above!). Be sure to close the ash door.

Before adding further fuel, be sure to leave a red spot of glowing coals in the center of the firebox to insure that the fire has not been smothered and to help ignite the gases given off by the new charge. A deep charge will give a more even heat and a longer fire, but it may take one to two hours before the whole bed is fully ignited.

When the fire is well established and the room is becoming warm, partially close the dampers. Some experimenting will have to take place with each particular setting of all dampers and controls as the chimney provides the draft necessary to not only exhaust the smoke, but to pull combustion air into the heater as well - and no two chimney's perform the same. Under ideal draft conditions, one should be able to turn the secondary air supply on the feed door

15

Operating Instructions

DO NOT USE MANUFACTURED OR CHARCOAL LOGS

FUEL RECOMMENDATIONS COAL

Most sizes of bituminous coal will work in your heater; for best results we recommend large nut coal to small egg coal (1-3/4" diameter to 4" diameter). When burning anthracite, use egg or broken with sizes between 2-5/16" and 4-3/8". Note that it is important to the life of your stove to buy coal which has been sized and cleaned. Cleaning insures removal of rocks and other materials.

DO NOT burn coke, charcoal, high volatile bituminous coal, sub bituminous, lignite or canal coal (sometimes called channel coal or candle coal).

STORE COAL IN A DRY, WELL VENTILATED AREA.

CAUTION! NEVER USE THE MANUFACTURED COAL BRICKS THAT ARE MADE FROM COAL DUST AND A WAX TYPE BINDER.

LIGHTING

1. Set the thermostat on "HIGH" and open both spin dampers on the feed and ash door for maximum draft.
2. Open the feed door and place paper and wood kindling on the grate for starting the fire.
3. Light the kindling and close the door.
4. Once a fire is established and burning briskly, add approximately 15 pounds of coal, being careful not to smother out the kindling fire.

For the first few burns, build small fires to allow the cast iron components and painted cabinet parts to season or cure. Your new stove will emit some smoke and odors from the curing process but should only do so for a short period of time. We suggest opening a window in the room of which the unit is installed.

ADDING FUEL

When maintaining a fire, add small amounts of fuel periodically as required (enough to burn for 3 to 5 hours). As you become more familiar with the operation of your heater, it is possible to add coal to burn for longer durations of 8 to 10 hours. But doing so carelessly will promote incomplete combustion and considerable sooting along with a very dirty, inefficient fire.

1. Always set the thermostat to high before opening the feed door to refuel or stoke the fire.
2. When opening the feed door, turn handle and open door until it stops on the latch and leave it at that position for at least 10 seconds before opening fully.

This, along with step 1 above, will allow any accumulated gases or smoke to exit into the chimney, eliminating flame or smoke spillage into the room.

3. If need be, shake the grate vigorously back and forth to dump the ashes into the ash pan. Do this at least once every 12 hours of operation.
4. Never smother the fire when adding fuel.
5. Add fresh kindling if the bed of coals has cooled.
6. Never add fuel above the top of the firebrick.
7. Be sure the new fuel is burning before you close the door and adjust combustion air.
8. Refer to the Bulletin RC454 in this manual for more information on burning coal.
9. Adjust dampers and air shutters to obtain the burn you desire. The air shutter on the thermostat control should never be closed complete when burning coal.
10. Empty ash pan regularly. Do not allow the ashes to build up to the grate as the grate will warp and burnout will occur. Allowing ashes to build up may also result in ash spillage when removing the ash pan. Dispose of hot ashes properly (See Maintenance).

CAUTION!

HOT WHILE IN OPERATION. KEEP CHILDREN, CLOTHING, FURNITURE AWAY. CONTACT MAY CAUSE SKIN BURNS.

NEVER USE GASOLINE, GASOLINE-TYPE LANTERN FUEL, KEROSENE, CHARCOAL LIGHTER FLUID, OR SIMILAR LIQUIDS TO START OR "FRESHEN UP" A FIRE IN THIS HEATER. KEEP ALL SUCH LIQUIDS WELL AWAY FROM THE HEATER WHILE IT IS IN USE.

DO NOT OPERATE THIS HEATER WITH THE FEED OR ASH DOOR OPEN. THIS HEATER IS DESIGNED FOR THERMOSTATIC OPERATION. OPERATING WITH EITHER DOOR OPEN WILL OVERHEAT AND DAMAGE THE HEATER.

ALWAYS CLOSE THE DOORS AFTER THE IGNITION.

NEVER OVERFIRE YOUR STOVE. IF ANY PART OF THE STOVE STARTS TO GLOW RED, OVER FIRING IS HAPPENING. READJUST THE AIR INTAKE CONTROL TO A LOWER SETTING.

BUILD FIRES DIRECTLY ON THE GRATE IN THE HEATER.

DO NOT BURN GARBAGE, FLAMMABLE FLUID SUCH AS GASOLINE, NAPHTHA OR MOTOR OIL.

DO NOT STORE FUEL OR OTHER COMBUSTIBLE MATERIALS WITHIN THE MINIMUM CLEARANCES SPECIFIED IN THIS MANUAL OR WITHIN THE SPACE REQUIRED FOR CHARGING AND ASH REMOVAL. DOING SO COULD RESULT IN A HOUSE FIRE.

NEVER ALTER THE ADJUSTMENT RANGE OR AIR INLETS TO INCREASE FIRING FOR ANY REASON.

Combustible Wall Chimney Connector Pass-Throughs

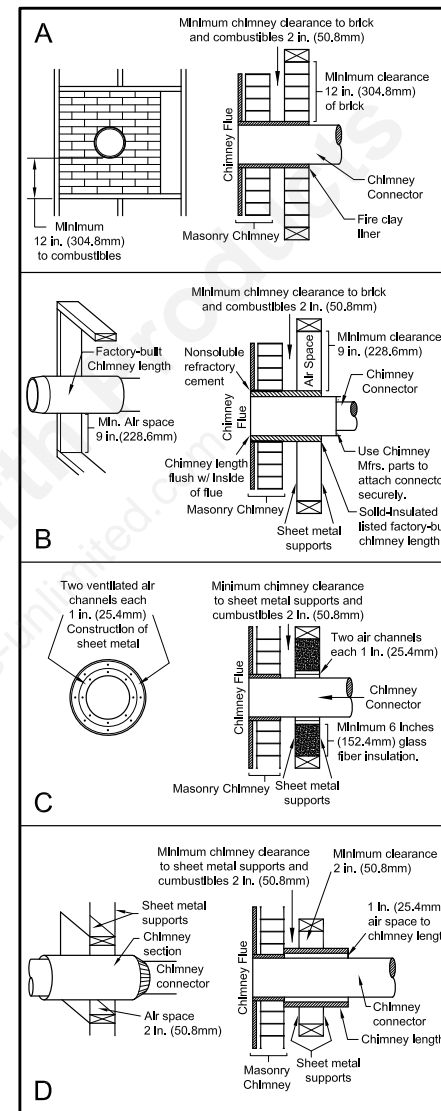

Method A. 12" (304.8 mm) Clearance to Combustible Wall Member: Using a minimum thickness 3.5" (89 mm) brick and a 5/8" (15.9 mm) minimum wall thickness clay liner, construct a wall pass-through. The clay liner must conform to ASTM C315 (Standard Specification for Clay Fire Linings) or its equivalent. Keep a minimum of 12" (304.8 mm) of brick masonry between the clay liner and wall combustibles. The clay liner shall run from the brick masonry outer surface to the inner surface of the chimney flue liner but not past the inner surface. Firmly grout or ce-

ment the clay liner in place to the chimney flue liner.

Method B. 9" (228.6 mm) Clearance to Combustible Wall Member: Using a 6" (152.4 mm) inside diameter, listed, factory-built Solid-Pak chimney section with insulation of 1" (25.4 mm) or more, build a wall pass-through with a minimum 9" (228.6 mm) air space between the outer wall of the chimney length and wall combustibles. Use sheet metal supports fastened securely to wall surfaces on all sides, to maintain the 9" (228.6 mm) air space. When fastening supports to chimney length, do not penetrate the chimney liner (the inside wall of the Solid-Pak chimney). The inner end of the Solid-Pak chimney section shall be flush with the inside of the masonry chimney flue, and sealed with a non-water soluble refractory cement. Use this cement to also seal to the brick masonry penetration.

Method C. 6" (152.4 mm) Clearance to Combustible Wall Member: Starting with a minimum 24 gage (.024" [.61 mm]) 6" (152.4 mm) metal chimney connector, and a minimum 24 gage ventilated wall thimble which has two air channels of 1" (25.4 mm) each, construct a wall pass-through. There shall be a minimum 6" (152.4 mm) separation area containing fiberglass insulation, from the outer surface of the wall thimble to wall combustibles. Support the wall thimble, and cover its opening with a 24-gage minimum sheet metal support. Maintain the 6" (152.4 mm) space. There should also be a support sized to fit and hold the metal chimney connector. See that the supports are fastened securely to wall surfaces on all sides. Make sure fasteners used to secure the metal chimney connector do not penetrate chimney flue liner.

Method D. 2" (50.8 mm) Clearance to Combustible Wall Member: Start with a solid-pak listed factory built chimney section at least 12" (304 mm) long, with insulation of 1" (25.4 mm) or more, and an inside diameter of 8" (2 inches [51 mm] larger than the 6" [152.4 mm] chimney connector). Use this as a pass-through for a minimum 24-gauge single wall steel chimney connector. Keep solid-pak section concentric with and spaced 1" (25.4 mm) off the chimney connector by way of sheet metal support plates at both ends of chimney section. Cover opening and support chimney section on both sides with 24 gage minimum sheet metal supports. See that the supports are fastened securely to wall surfaces on all sides. Make sure fasteners used do not penetrate chimney flue liner.

NOTES:

1. Connectors to a masonry chimney, excepting method B, shall extend in one continuous section through the wall pass-through system and the chimney wall, to but not past the inner flue liner face.

CABINET DOOR KNOB ASSEMBLY

The cabinet door knob is mounted on the inside of the cabinet door to facilitate shipping and must be removed and re-installed for proper usage.

To get the cabinet door open, place your hand under the cabinet frame (right hand side of the cabinet door) and push door out.

FOLLOW THESE INSTRUCTIONS FOR DOOR KNOB ASSEMBLY:

1. Remove the machine screw and the door knob.
2. Place the knob on the outside of the cabinet door, re-install the machine screw and tighten being careful not to strip out the threads in the plastic handle.

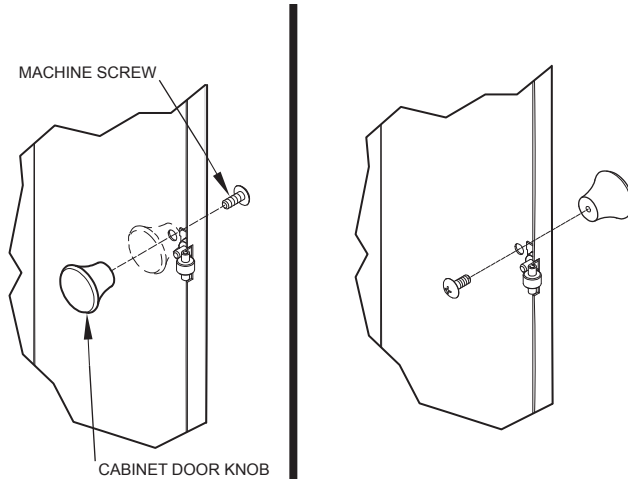

CB36 ROOM BLOWER ASSEMBLY

NOTICE: The CB36 is standard equipment on the model B2350B. If you wish to purchase an assembly, you can contact your dealer for details or get it directly from the U.S. Stove Company.

INSTALLATION

1. Remove the Panel (A) using tin snips or knock out using a hammer and chisel careful not to distort the mounting surface.
2. Attach the Blower Mounting Box (B) to the rear of the unit using four(4) of the supplied #10 screws.
3. Then mount the Blower Assembly with the four(4) remaining screws.

OPERATION

1. Rotating the rheostat control knob clockwise will turn ON the blower.
2. When turned on, the blower comes on HIGH, then as the knob is rotated clockwise, the blower speed reduces.
3. Rotate the knob counter-clockwise to turn OFF.

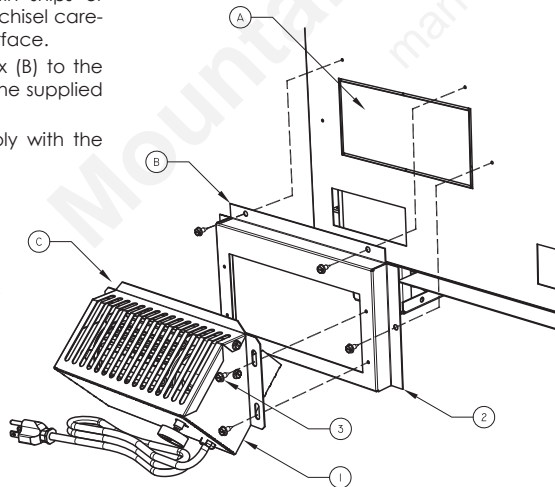

12

INSTRUCTIONS FOR TWO-STEP LATCH OPERATION

Follow these instructions to operate you unit safely when operating the feed door.

1. Turn handle clockwise to the 12 o'clock position (A), pull the door open until you engage the second step (B).
2. Hold the door in that position for approximately 10 seconds.
3. Then to open door, turn the handle counter clockwise to the 9 o'clock position (C) and then continue to pull the door open. (D)
4. To close and latch the door, reverse steps 1 thru 4.

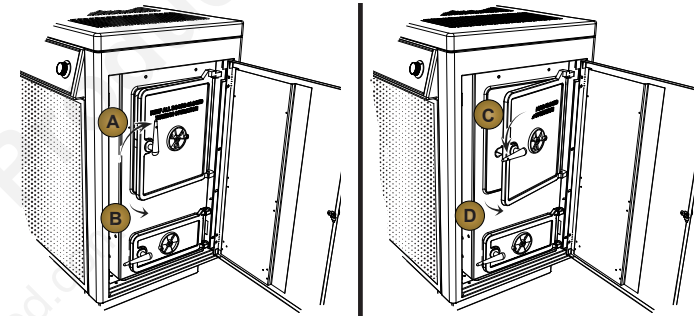

NOTE:
THIS NEW LATCHING MECHANISM MEETS CODES AND PROVIDES MORE SAFETY FOR THE USER OF THIS STOVE.

NOTE:
DURING OPENING AND CLOSING OF THE FEED AND ASH DOORS OF THIS HEATER, IT MAY SEEM THAT THE FIT OF THE DOOR IS "TOO TIGHT". AS THE HEATER IS FIRED, THE GASKETING "SETTLES" OR "SEATS" ITSELF IN THE DOOR. THE TIGHT FIT AT THE FACTORY AND BEFORE THE HEATER'S INITIAL FIRING IS TO INSURE A GOOD SEAL AFTER THE GASKETING "SETTLES".

HOW TO OPEN THE TOP LID

CAUTION! DO NOT OPEN OR CLOSE THE TOP WHEN THE HEATER IS HOT!

To open, grasp the top at the front or on each corner and lift all the way up until the support rod stops the motion. Then gently lower the top allowing the support rod to settle in the cup, holding the top open.

To Close, lift the top until the support rod is out of the cup. Pull the rod forward and lower the lid closed.

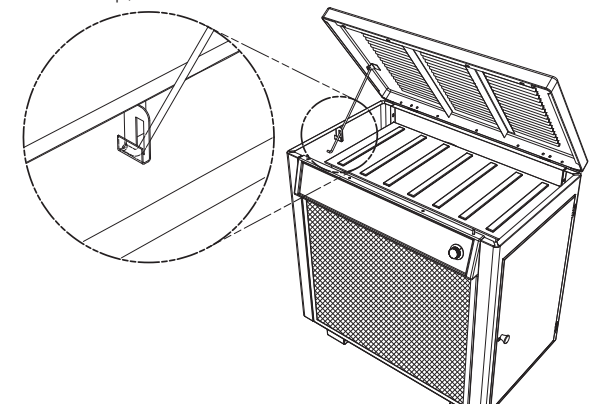

13