

Sears

owners manual

MODEL NUMBER
143.840825



U.L. FILE NUMBER
MH 10475



REPORT
NO. 2073

CAUTION:
Read All Instructions
Carefully Before
Starting the Installation
or Operating the Heater

**DO NOT USE THIS
HEATER IN MOBILE
HOMES OR TRAILERS**

Save This Manual
For Future Reference

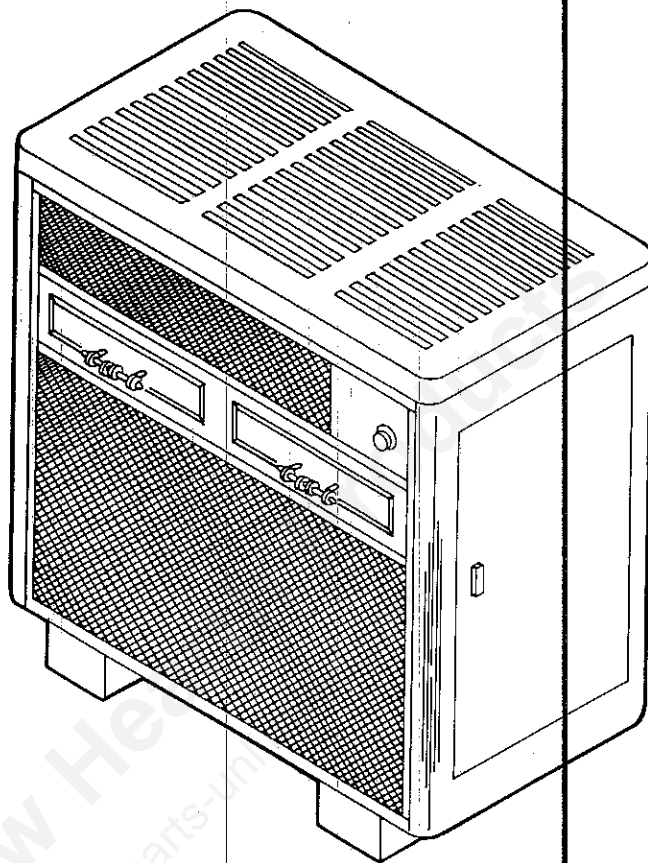

AUTOMATIC COAL OR WOOD BURNING CIRCULATOR HEATER

- Assembly
- Installation
- Operation
- Repair Parts

Sears, Roebuck and Co., Chicago, Ill. 60684 U.S.A.

PRINTED IN U.S.A.

FDRM 85337F 6/85

introduction!

Please read our instructions before you install and use your new Coal or Wood Burning Circulator Heater. This will help you obtain the full benefits from your heater.

If you want your heater professionally installed, contact your SEARS SALESPERSON. They will arrange for prompt, quality installation by SEARS AUTHORIZED INSTALLERS.

ATTENTION NEW OWNER! Please Read Before Using Heater

This solid fuel room heater is designed to operate at a very high efficiency. With the incorporation of a stainless steel heat exchanger in the top of the combustion chamber, it is designed to retain a high percentage of the heat that normally goes out the chimney with other heaters. Due to this unique design when the thermostat is set on high or during "heat up" periods, in a dimly lighted or dark room,

you may see a slight glow appear on the top of the combustion chamber in the heat exchanger area. DO NOT BE ALARMED — this unit is designed and constructed of quality materials to withstand temperatures in excess of 1000° F; and if operated in accordance with instructions in this manual, the unit will give you years of comfortable and economic service.

SEARS INSTALLATION POLICY

All installation labor arranged by SEARS shall be performed in a neat, workman-like manner in accordance with generally accepted trade practices. Further, all installations shall comply with all local

laws, codes, regulations, and ordinances. The customer shall also be protected, during installation, by insurance relating to property damage, workmen's compensation and public liability.

SEARS INSTALLATION WARRANTY

In addition to any warranty extended to you on the Sears merchandise involved, which warranty becomes effective the date the merchandise is installed, should the workmanship of any Sears

arranged installation prove faulty within one year, Sears will, upon notice from you, cause such faults to be corrected at no additional cost to you.

tools and materials needed

TOOLS

Pencil
6 Foot Folding Rule or Tape
Tin Snips
Drill, Hand or Electric
Drill Bit (For Sheet Metal Screws)
1/8" Dia.
Gloves
Screwdriver (Blade-Type)
5/16" Nut Driver
or 5/16" Socket w/Ratchet.

MATERIALS

Chimney Connector-6" dia. Black or Blued Steel (24 ga. minimum): Straight or Elbow (as required)
1/2" Sheet metal screws (10A x 1/2")
6" Inside diameter Underwriters Laboratories (UL) Listed Residential Type and Building Heating Appliance Chimney or existing masonry chimney.
Floor Protector Material 3'-0" x 4'-6"
as specified on Page 4.
Furnace Cement (Rutland Black Code 78 or Equivalent is recommended)

rules for safe installation and operation

SAFETY NOTICE: If this heater is not properly installed, a house fire may result. For your safety, follow the installation directions. Contact local building or fire officials about restrictions and installation inspection requirements in your area.

Read these rules and the instructions carefully.

1. Check your local codes. The installation must comply with their rulings.
2. Do not install this heater in a mobile home or trailer.
3. Always connect this heater to a chimney and vent to the outside. Never vent to another room or inside a building.
4. Do not connect a wood burning heater to an aluminum Type B gas vent. This is not safe and is prohibited by the National Fire Protection Association Code. This heater requires a masonry or a UL Listed Residential Type and Building Heating Appliance Chimney. Use a 6" diameter Chimney or larger, that is high enough to give a good draft.
5. Be sure that your Chimney is safely constructed and in good repair. Have the chimney inspected by the Fire Department or a qualified inspector. Your insurance company may be able to recommend a qualified inspector.
6. Inspect chimney connector and chimney twice monthly during the heating season for any deposit of creosote or soot which must be removed (see Chimney Maintenance, page 15).
7. Provide air for combustion from outside the house into the room where the heater is located. If the intake is not in the same room, air must have free access to the room.
8. **CAST IRON PARTS MUST BE "SEASONED" TO AVOID CRACKING. BUILD ONLY SMALL FIRES ON FIRST USE.**
9. To prevent injury, do not allow anyone to use this heater who is unfamiliar with the correct operation of the heater.
10. For further information on using your heater safely, obtain a copy of the National Fire Protection Association (NFPA) publication "Chimneys, Fireplaces, Vents, and Solid Fuel Burning Appliances" NFPA No. 211. The address of the NFPA is Batterymarch Park, Quincy, MA 02269.
11. Keep the ashpit section free of excess ashes. Do not allow ashes to stack higher than the sides of the ash pan.
12. **DISPOSAL OF ASHES-** Ashes should be placed in a metal container with a tight fitting lid. The closed container of ashes should be placed on a noncombustible floor or on the ground, well away from all combustible materials, pending final disposal. If the ashes are disposed of by burial in soil or otherwise locally dispersed, they should be retained in the closed container until all cinders have thoroughly cooled.
13. **CAUTION-** The special paints used on your heater may give off some smoke and/or odors while they are curing during first few fires. Build small fires at first. The metals used in construction of the heater has a light coating of oil. This could give off smoke and/or odors when heater is used for the first couple of times. This should disappear after a short period of time. Once this burn-off has occurred, it should not reoccur.
14. **CARING FOR PAINTED PARTS -** This heater has a painted outside jacket, which is durable but it will not stand rough handling or abuse. When installing your heater, use care in handling. Clean with soap and warm water when heater is not hot. **DO NOT** use any acids or scouring soap, as these wear and dull the finish. **PAINT DISCOLORATION WILL OCCUR IF THE HEATER IS OVERFIRED. FOLLOW OPERATING INSTRUCTIONS CAREFULLY.**
15. Keep the feed door, ash door, cabinet door closed at all times except while tending the heater.
16. Use wood or coal only. **DO NOT USE** the coal bricks that are manufactured from coal dust and a wax-type binder.

CAUTION:

Do not touch the heater until it has cooled.

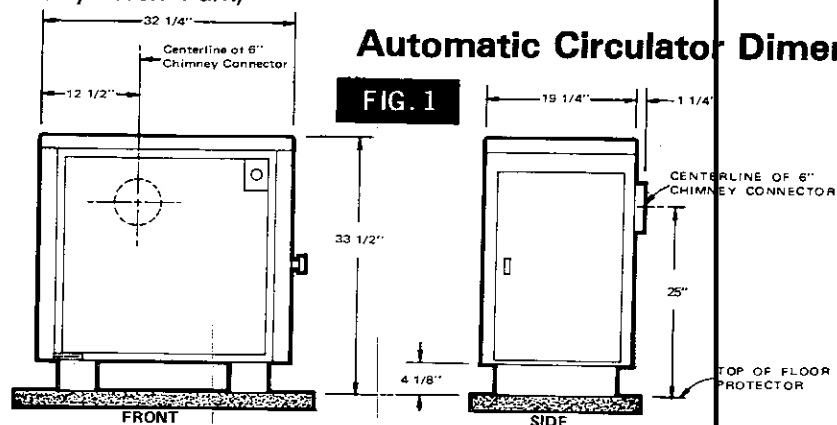

locating the heater

AS A LOCATION IS SELECTED, KEEP THE FOLLOWING IN MIND:

1. The chimney connection should be as short as possible. The heater must have its own chimney. Do not connect this unit to a chimney flue serving another appliance. If there is no chimney near where you wish to place the heater, you can use a UL Listed Residential Type and Building Heating Appliance Chimney (Fig. 6).
2. Place the heater on solid masonry or solid concrete. When the heater is used on a combustible floor, use a non-combustible floor protector 3/8" millboard having a thermal

conductivity of $K=0.84$ BTU in/ft.² hr. deg. F with 28 gauge sheet metal or a U.L. listed floor protector. Have the floor protector extend 16" beyond the door side of the heater and under the connector pipe in the back (Fig. 4, 5, and 6).

3. Check Figures 2, 3 and 4. Be sure you have the clearances shown from the heater and the connector pipe to combustible surfaces. If you have a solid brick or stone wall behind your heater, you can place the heater as close as you wish to the wall. If the wall is only faced with brick or stone, treat it as a combustible wall.

MINIMUM CLEARANCE TO COMBUSTIBLE WALLS

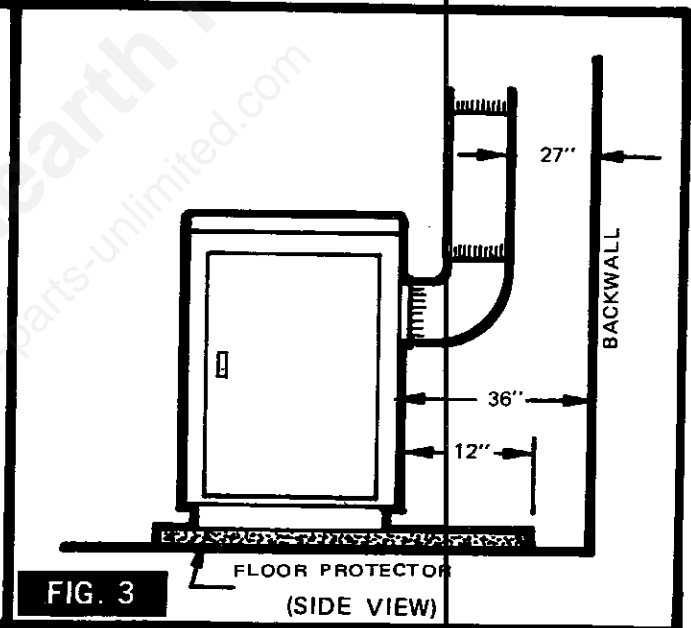
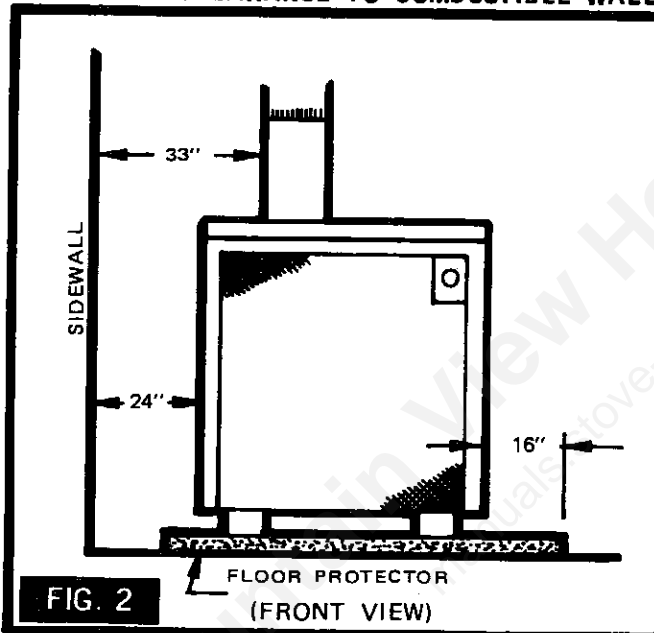

CAUTION
Keep furnishings and other combustible materials away from the appliance.

NOTE: BEFORE FIRING HEATER

1. Remove plastic knob from inside of cabinet door and install on outside. (See Page 10).
2. Slide firebricks toward the rear so no gaps remain between them.

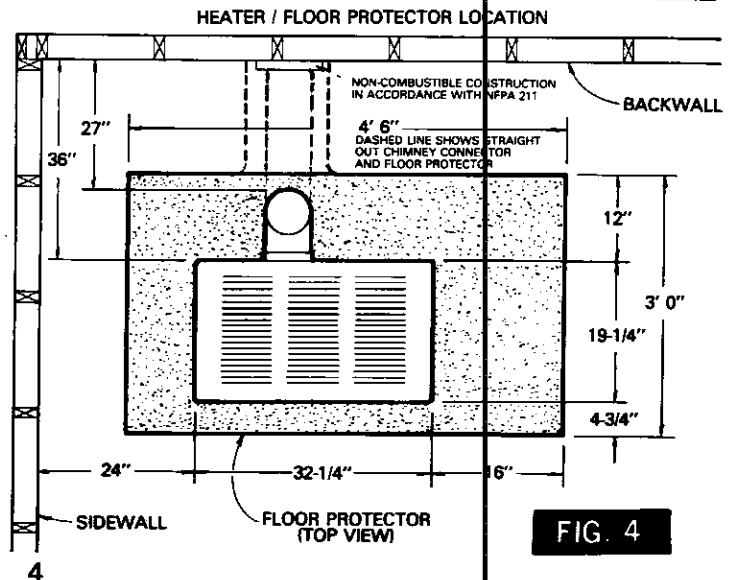

chimney connection

MASONRY CHIMNEY

Before using an existing masonry chimney, clean the chimney and inspect the flue liner to be sure it is safe to use. Make repairs before attaching the heater.

Look at Fig. 5. The connector pipe and fittings you will need to connect directly to a masonry chimney are shown.

If the connector pipe must go through a combustible wall before entering the masonry chimney, consult a qualified mason or chimney dealer. The installation must conform to local fire codes.

Do not connect this heater into the same chimney flue as the fireplace or flue from another heater.

The chimney used for a heater must not be used to ventilate the cellar or basement. If there is a cleanout opening at the base of the chimney, close it tightly.

UL LISTED CHIMNEY

Carefully follow chimney manufacturer's instructions. Use only a UL Listed Residential Type and Building Heating Appliance Chimney. If your chimney starts at the ceiling (Fig. 6), you will need a 6" elbow and enough 6" pipe to reach the ceiling. You will also need the connector adapter Sears Stock No. 42-99185.

The top of the chimney must be at least 3 feet above the roof and be at least 2 feet higher than any point of the roof within 10 feet (Fig. 6).

BAROMETRIC DRAFT REGULATOR (Optional)

In some installations it may be desirable to install a barometric draft regulator in the chimney connector. A barometric draft regulator should be located in the same room (pressure zone) as the heater. When installing a barometric draft regulator, follow the manufacturer's instructions.

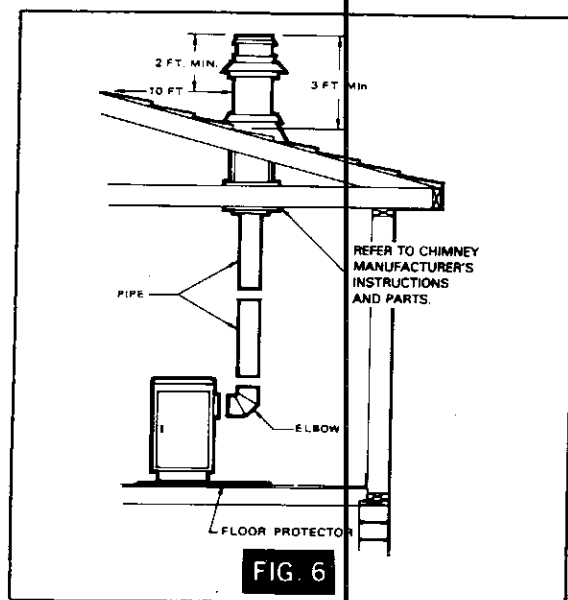
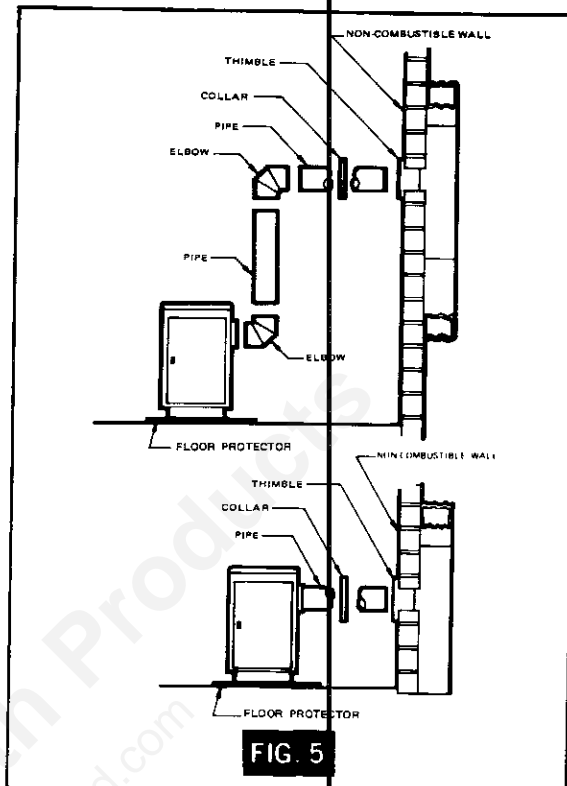

venting into a fireplace

Many people may wish to convert an existing fireplace to wood heater use. Usually, safe connection of stovepipe to a masonry chimney requires more effort than connection to a prefabricated chimney. There are two methods (Type A and Type B) to accomplish this. No matter which method you choose, the fireplace must be tightly closed and sealed at the damper in the flue. Good sealants are high-temperature caulking, ceramic wool, and furnace cement. Always remember to inspect the masonry chimney and fireplace. If necessary, clean the flue and smoke shelf before beginning your installation. Install the wood heater into the fireplace so that the system can be dismantled for cleaning and inspection.

Before deciding to convert your fireplace, keep in mind that some fireplaces and existing chimneys are unsafe. They must be structurally sound, and the flue liner must be in good condition. Clearances to combustibles are explained in the previous section on masonry chimneys. If you have any question regarding the condition of the chimney, consult a qualified engineer, competent mason, or knowledgeable inspector.

CAUTION

NOT ALL FIREPLACES ARE SUITABLE FOR INSTALLATION OF A WOOD HEATER.

Many prefabricated fireplaces fall into the "zero-clearance fireplace" category. This is a factory-built metal fireplace with multilayered construction. It is designed to provide enough insulation and/or air cooling so that the base, back, and sides can be safely placed in direct contact with combustible floors and walls. Although many prefabricated fireplaces have been tested by nationally recognized organizations for use as fireplaces, they have not been tested to accept airtight wood heaters. In fact, their use as such may void the manufacturer's warranty.

Steel-lined fireplaces, on the other hand, can be used with airtight wood heaters. These units use a 1/4-inch firebox liner and an air chamber in connection with 8 inches of masonry to meet code. They contain all the essential parts of a fireplace; firebox, damper, throat, smoke shelf, and smoke chamber. Many of them look exactly like a masonry fireplace and must be checked closely for above requirements before installing a wood heater into them.

Another method frequently used by some people is to vent the wood heater directly into the fireplace. This does not meet code since the heater is being vented into another appliance—the fireplace. This method should not be attempted because combustion products will deposit and build up in the firebox or fireplace. Be certain not to install a hazard in your house.

Type A Installation

Connection of the stovepipe directly into the existing masonry chimney over the fireplace opening is the most desirable method. This installation performs better, yielding more heat and better draft; it is also easy to clean and inspect for creosote. Before beginning this type of installation plan carefully; a high degree of skill is required to insure safety.

An entry port for the stovepipe must be cut through the chimney with minimum damage to the fireclay liner. Some involved measurements may be required to locate the flue liner exactly. Before cutting, take time to mark the size and position of the entry port. Position the entry port so that at least 8 inches of the flue liner remain below the port.

Keep in mind that wood mantels and combustible trim around the fireplace must have adequate clearances from the heater and stovepipe or must be protected in an approved manner. Also, be sure to leave at least an 18-inch clearance between the top of the stovepipe and the combustible ceiling or other combustibles. Placing the center of the entry port 2 feet below the ceiling will insure proper clearance for 6-inch, 8-inch, and 10-inch stovepipes.

Next, install a fireclay (at least 5/8 inch thick) or metal thimble, being sure that the thimble is flush with the inner flue lining; secure the thimble in place with refractory mortar. The thimble should be surrounded on all sides with 8 inches of brickwork (solid masonry units) or 24 inches of stone.

Install the stovepipe as far as possible into the thimble, but not past the inside of the flue lining. There should be a small airspace (approximately 1/2 inch) between the stovepipe and thimble, allowing for expansion of the stovepipe. Seal this airspace with high-temperature caulking or ceramic wool. Finally, be sure to wire the damper closed and apply the same sealant you used at the stovepipe and thimble junction.

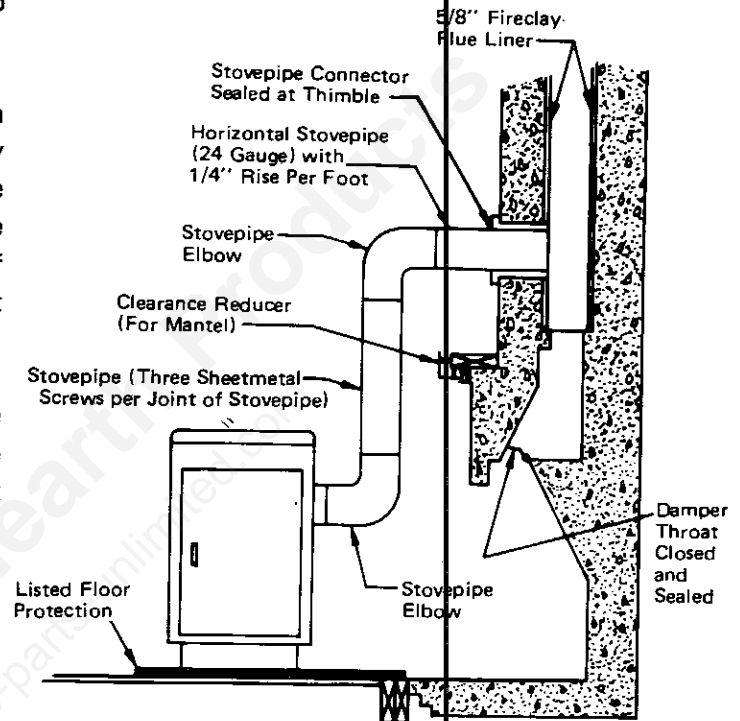

TYPE A **FIG. 7**
FIREPLACE CONVERSION

Type B Installation

The next method, Type B, is acceptable but is more difficult to operate and maintain than Type A. Remove the damper and cut a hole in the sheet metal to rest on the damper frame. Cut a hole in the sheet metal to accept the stovepipe. Insert the stovepipe as far as possible into the flue past the throat or damper plate. (If the end of the stovepipe which protrudes past the damper is cut at an appropriate angle, resistance to passage of flue gases can be minimized.) Finally, fasten all junctions

between the sheet metal and damper frame and between the sheet metal and stovepipe. For an airtight system, be sure to seal these junctions with high-temperature caulking, ceramic wool, or furnace cement. Instead of a sheet metal closure at the damper, a prefabricated flue adaptor of 12 gauge, low-carbon steel or stainless steel may be sealed into place to accept the stovepipe. Be sure to fasten and seal the stovepipe to the flue adaptor.

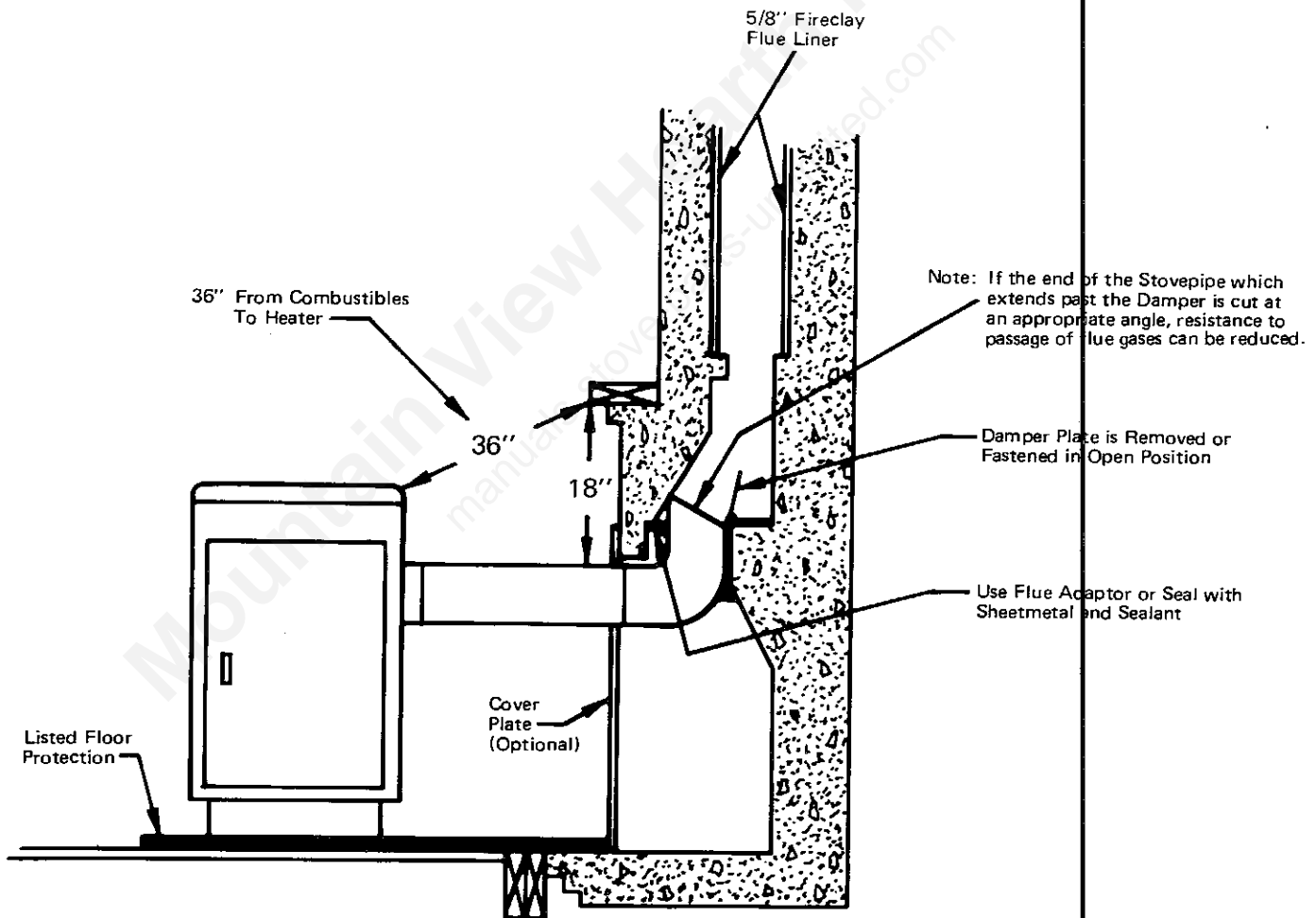

TYPE B **FIG. 8**
FIREPLACE CONVERSION

Rules For Connector Pipe Installation

1. The crimped end of the stovepipe fits inside the heater flue collar. Install additional pipe and elbow with the **CRIMPED END TOWARD THE HEATER**. This will allow any condensation in the flue to run back into the heater.
2. Slope any horizontal pipe upward toward the chimney at least $\frac{1}{4}$ inch for each foot of horizontal run.
3. You must have at least 18 inches of clearance between any horizontal piping and the ceiling.
4. The pipe cannot extend into the chimney flue (Fig. 9).
5. Seal each connector pipe joint with furnace cement. Also seal the pipe at the chimney.
6. Use 3 sheet metal screws at each joint to make the piping rigid.
7. Do not put a damper in a connector pipe.
8. It is recommended that no more than two 90° bends be used in the stovepipe installation as more than two may decrease the amount of draw and possibly cause smoke spillage.

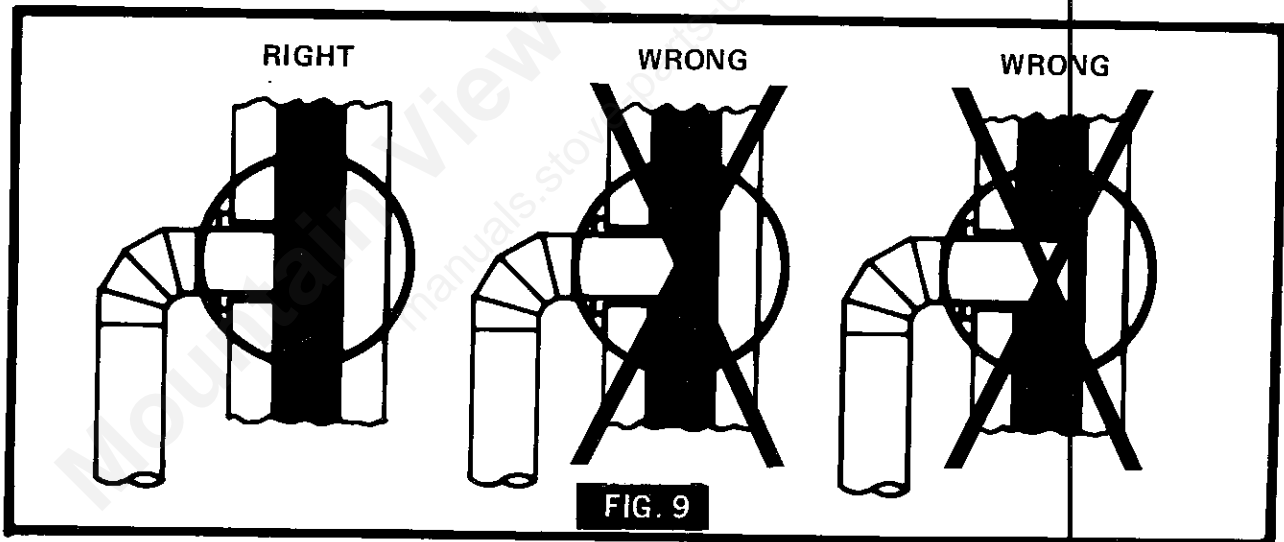

Cabinet Door Catch Assembly

The door knob is mounted inside of the cabinet door to facilitate shipping and must be reversed for proper usage.

To get cabinet door open, place hand under cabinet frame (right hand side — cabinet door side) and push door out.

INSTALL THE CABINET DOOR KNOB USING THE STEPS BELOW:

1. Remove the machine screw and door knob (Fig. 10).
2. Place door knob on outside of cabinet door. Then place machine screw through hole and into door knob and tighten (Fig. 11).

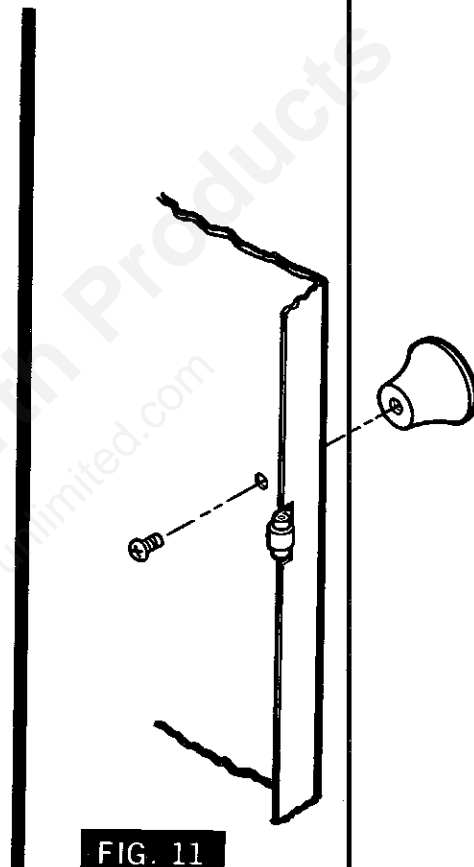
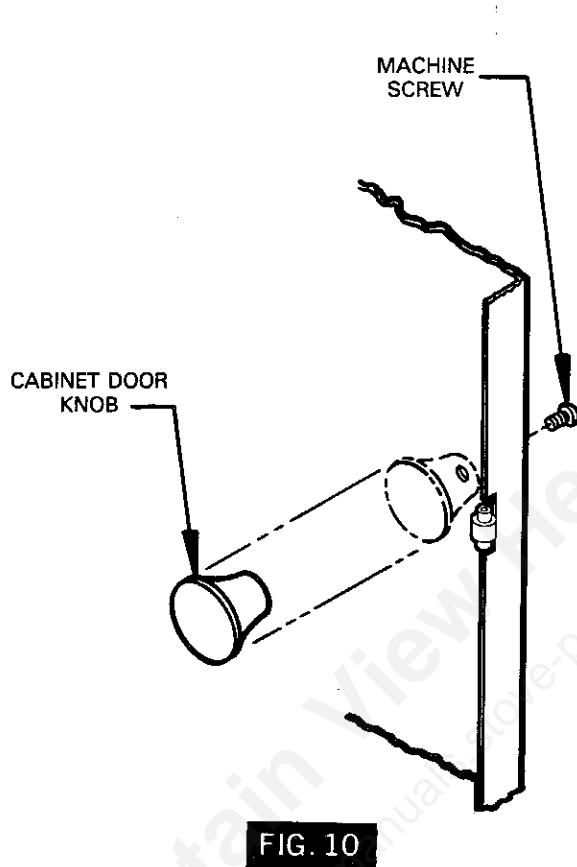

FEED/ASH DOOR HANDLE ASSEMBLY

Read and Complete Before Firing Unit

1. Remove wooden handle from inside of the ash pan.
2. Place the metal hook of the wooden handle through the hole in the end of the cast iron door handle.
3. Using pliers close the metal hook so the wooden handle cannot be removed.

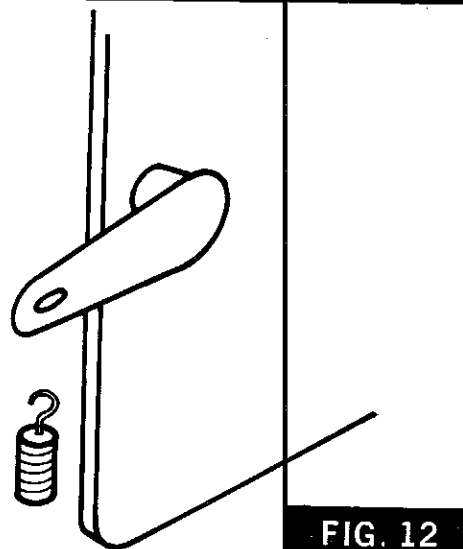

How To Use Your Heater

FUEL

Egg size (1-3/16 or larger) coal for residential furnaces. Coal with a low ash content (2% to 6%) is recommended. Do not use Cannel Coal. Hardwood, 18" to 22" should be split and air dried (seasoned) for 6 months.

NOTE: Store coal in a dry, well ventilated area.

LIGHTING

1. Set the thermostat on "HIGH" for maximum draft.
2. Open the feed door and place paper and kindling on the grate for starting the fire.
3. Light fire and close feed door.
4. Add wood or about 15 lbs. of coal after fire is burning briskly. Be careful not to smother the kindling fire.
5. Set thermostat for desired temperature. "MEDIUM" setting is normally satisfactory. Set higher or lower for your comfort.

ADDING FUEL

When possible, add small amounts of fuel each hour or so instead of adding large quantities of fresh fuel over long periods of time. This will give more complete combustion and less build-up of tars or soot in the chimney.

1. Set thermostat to HIGH before opening feed door.
2. Wood Fire - Do not add fuel above firebox liners.
3. Coal Fire - Never smother the fire when adding coal (see CAUTION below). Gas accumulation and a mild smoky explosion will occur.

CAUTION

GASES THAT ARE DRIVEN FROM FRESH COAL MUST BE BURNED OR THEY WILL ACCUMULATE AND EXPLODE. NEVER SMOTHER A FIRE WHEN ADDING FRESH COAL.

CAUTION

BUILD FIRE ON INTEGRAL GRATE PROVIDED WITH THE HEATER.

CAUTION

OVERFIRING THE APPLIANCE MAY CAUSE A HOUSE FIRE. IF A UNIT OR CHIMNEY CONNECTOR GLOWS, YOU ARE OVERFIRING.

- a. Add fresh kindling if the bed of coals has cooled.
 - b. Add up to 20 lbs. of coal. Never add coal above top of fire brick.
 - c. Stir the coal and watch the fire. Be sure the new coal is burning briskly before you close the doors and turn the thermostat down.
 - d. Adjust air shutter on feed door damper from closed to open position for better burning. (See Fig. 13).
4. Shake grates vigorously 1/2" towards and away from the ash door opening to dump ashes into the ash pan. Do this at least once every 12 hours of operation. Empty ash pan regularly. Do not allow ashes to build up to grate as grate will warp and burnout, and you might spill the ashes when removing the pan. Dispose of hot ashes properly (see Note 12 on Page 3).

CAUTION

DO NOT OPERATE THIS HEATER WITH FEED OR ASH DOOR OPEN. THIS HEATER IS DESIGNED FOR THERMOSTATIC OPERATION. OPERATION WITH EITHER DOOR OPEN WILL OVERHEAT AND DAMAGE THE HEATER.

WARNING

NEVER USE GASOLINE, GASOLINE-TYPE LANTERN FUEL, KEROSENE, CHARCOAL, LIGHTER FLUID, OR SIMILAR LIQUIDS TO START OR "FRESHEN UP" A FIRE IN THE HEATER.

WARNING

NEVER STORE FLAMMABLE LIQUIDS, ESPECIALLY GASOLINE, IN THE VICINITY OF THE HEATER.

WARNING

NEVER USE THE MANUFACTURED COAL BRICKS THAT ARE MADE FROM COAL DUST AND A WAX-TYPE BINDER.

SUGGESTIONS FOR BURNING ANTHRACITE COAL

1. Anthracite coal may be burned in the Model 143.840825. Always follow instructions that are shown in the Owners Manual.
2. With coal, as with wood, it is important to maintain a clean chimney. The chimney connector and chimney should be inspected at least twice monthly during heating season.
3. Keep the grate clear of ash and cinders. Use the shaker grate to keep the ashes from building up in the firebox.
4. Do not operate the unit with the ash door, feed door, or cabinet door open.
5. Anthracite coal burns with a short, blue flame with the coals having a glowing, red color. Before adding coal, when starting the fire, have a good hot log fire burning.
6. After having a log fire burning, add small amounts of coal until a bed of coal is built up.
7. Adjust air shutter on feed door damper from closed to open position for better burning. (See Fig. 13).
8. A draft reading of $-.05$ to $-.06$ in w.c. is required for anthracite to burn.

NOTE

Adjust air shutter on feed door damper from closed to open position for better burning. This air shutter should be in the open position only when burning coal.

The draft wheel located on the feed door should be opened when burning coal and closed when burning wood. The draft wheel provides a source of secondary air that is needed when burning coal. Secondary air is needed because when coal burns, it gives off large quantities of volatile gases that need additional air before complete combustion can occur. This draft wheel may be adjusted to give the best performance depending on the particular needs of the user.

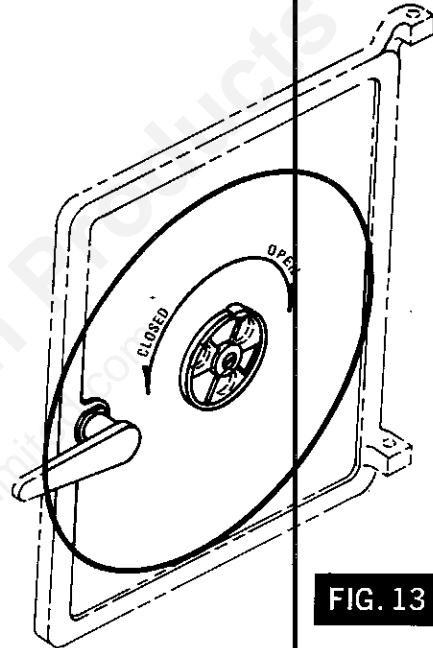

FIG. 13

Burning Anthracite Coal

Anthracite coal has different burning characteristics than wood or other coals. For a more effective burn of anthracite coal, it may be necessary to remove the throttle plate from behind the draft damper frame assembly as shown (Fig. 14). A step by step procedure for removing the throttle plate is listed below.

INSTRUCTIONS:

1. Open side cabinet door and ash door.
2. Remove ash pan.
3. With a short flat head screwdriver in your left hand and a ratchet wrench with $7/16$ " socket in your right hand, remove nuts and lockwashers from behind draft damper frame assembly as shown below.
4. Holding draft damper frame assembly in left hand, pull assembly away from heater.
5. Remove throttle plate from assembly as shown below.
6. Replace draft damper frame assembly by reversing Steps 3 and 4.
7. Replace ash pan.
8. Close ash door and cabinet side door.

CAUTION

Keep the throttle plate for future use. When burning bituminous coal or wood, it is necessary that the throttle plate be in place behind the draft damper frame assembly to prevent possible overfiring of the unit.

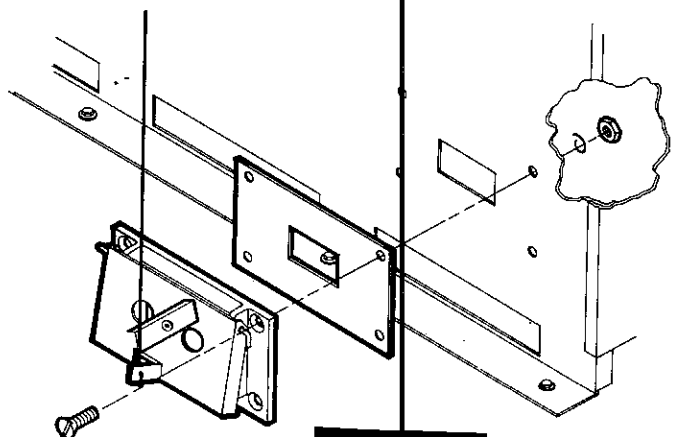

FIG. 14

Instructions for Two-Step Latch Operation

1. Follow these instructions to operate your unit safely when operating the feed door.
2. Turn handle clockwise to the 12 o'clock position, pull the door open until you engage the second step. (Fig. 15).
3. Hold the door in that position for approximately 10 seconds.
4. Then to open door, turn the handle counter clockwise to the 9 o'clock position and then continue to pull the door open. (Fig. 16).
5. To close and latch the door, reverse steps 4 thru 2.

NOTE

THIS NEW LATCHING MECHANISM MEETS CODES AND REGULATIONS AND PROVIDES MORE SAFETY FOR THE USER OF THIS STOVE.

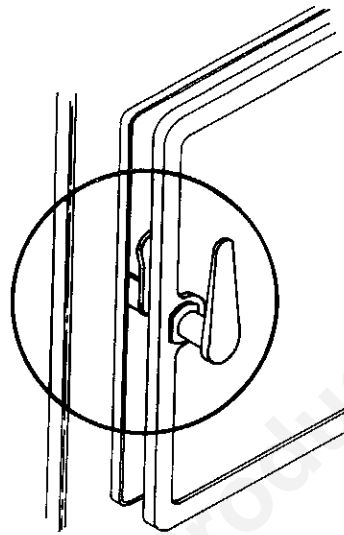

FIG. 15

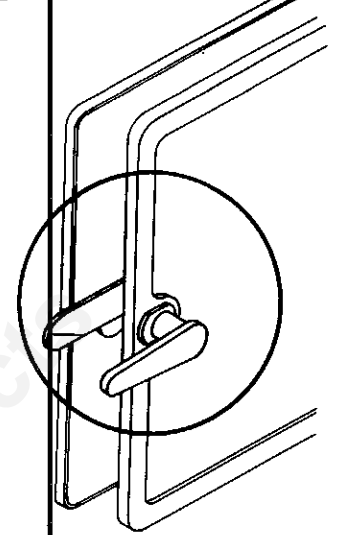
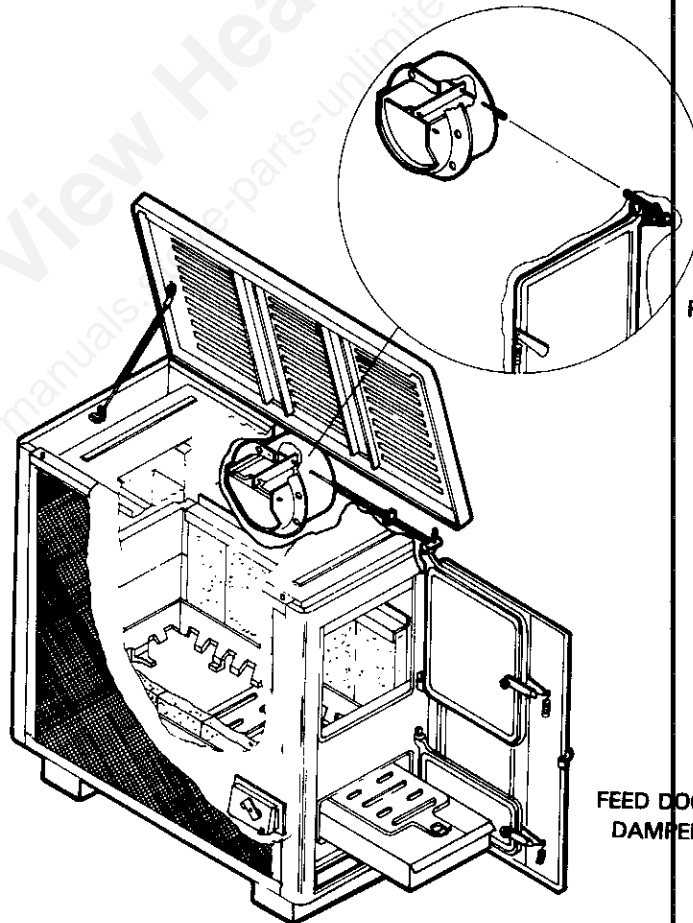

FIG. 16

CAUTION
THIS HEATER IS DESIGNED WITH A FLUE COLLAR DAMPER WHICH OPERATES AUTOMATICALLY WHEN THE FEED DOOR IS OPENED AND CLOSED. IF THE UNIT SMOKES WHEN THE FEED DOOR IS OPEN, CHECK THE FLUE COLLAR DAMPER TO SEE THAT IT IS OPEN ALSO. FAILURE OF THE DAMPER TO OPERATE PROPERLY MAY CAUSE SMOKE AND FLAME TO ESCAPE THROUGH THE FEED DOOR IN THE OPEN POSITION. (FIG. 17)



FEED DOOR CLOSED,
DAMPER CLOSED

FEED DOOR OPEN
DAMPER OPEN

FIG. 17

adjusting the thermostat

The thermostat control was adjusted at the factory. The operation of the heater may require a change in calibration. Calibration adjustments should be made at room temperature.

If the thermostat adjustment is not satisfactory, the thermostat operating range may be changed as follows:

- A. To increase the amount of heat at a "HIGH" setting, adjust the wire linkage to increase the draft damper opening (Fig. 18).
 1. Unhook linkage wire at Point "C".
 2. Take Point "A" in left hand and "B" in right hand, then turn "B" clockwise about 3 turns.
 3. Then hook linkage wire back to draft control damper door at Point "C".
- B. To decrease the amount of heat at "LOW" setting:
 1. Check feed and ash doors to be sure that they are closed tightly.
 2. Check the connector pipe to see that it is sealed at all connecting points.
 3. If no air leaks are found, adjust linkage as above except turn "B" counterclockwise about 3 turns.
- C. Adjusting the minimum air shutter (The minimum air shutter has an infinite number of settings. Several adjustments may be necessary for the unit to work most effectively for your particular installation):
 1. The minimum air shutter may be adjusted to the closed position in installations where the draft is "above normal," generally, .06 w.c. or above would be considered "above normal."
 2. In installations where the draft is "below normal," the minimum air shutter should be adjusted toward the open position.

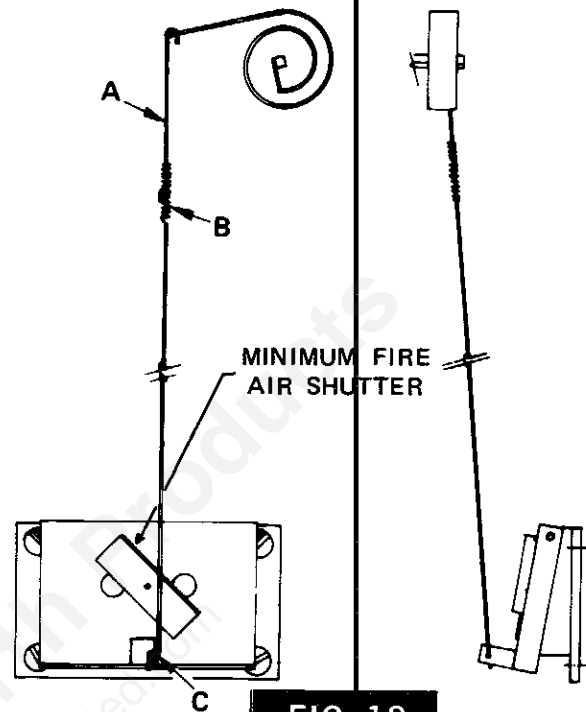

FIG. 18

NOTE: More than one readjustment may be necessary. At room temperature (72° F) and "LOW" setting, the draft damper door should be closed.

How To Lift The Top

CAUTION - DO NOT OPEN OR CLOSE TOP WHEN HEATER IS HOT! To open, lift the front edge of the cabinet top to the full open position. Then gently lower the TOP until the TOP SUPPORT ROD latches in the Top Support seat, to hold the top. (Fig. a)–To close, lift TOP until the TOP SUPPORT ROD is unlatched. Pull the ROD forward and lower the TOP (Fig. b).

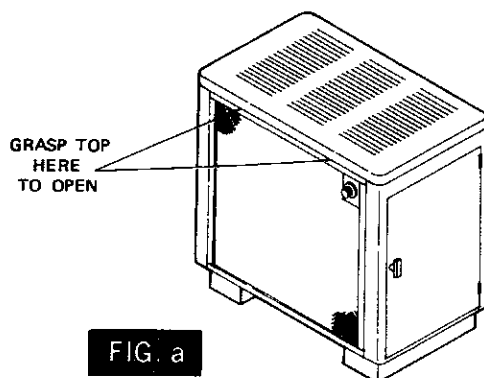

FIG. a

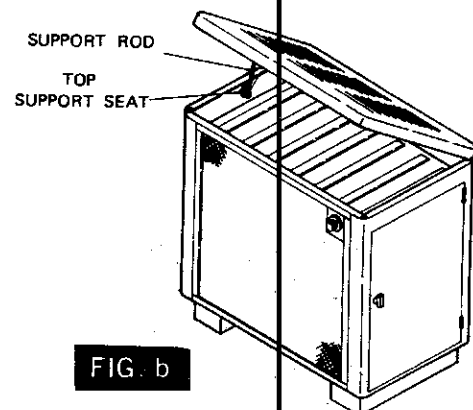

FIG. b

minimum fire

The burning rate at the low setting can be further adjusted by opening or closing the minimum fire air shutter (Fig. 18) on the draft control door.

1. Partially close the shutter to make the fuel burn longer.

2. Open the shutter, exposing a large opening, to reduce the formation of creosote or soot (see notes on Chimney Maintenance).
3. Do not operate the heater with the minimum fire air shutter completely closed.

service hints

Do not expect a heater to draw. It is the chimney that creates the draft. Smoke spillage into the house or excessive build-up of water or creosote in the chimney are warnings that the chimney is not drawing properly. Correct the problem before using heater. Possible causes are:

1. The connector pipe may be pushed into the chimney too far, stopping the draft (Fig. 9).
2. Do not connect two heaters into the same chimney flue.
3. Do not use the chimney to ventilate the cellar or basement. If there is a cleanout opening at the base of the chimney, close it tightly.

4. If the chimney is too cool, moisture will condense in the chimney and run back into the heater. Creosote formation will be rapid and may block the chimney. Build your heater fire large enough to keep the chimney warm to prevent condensation.
5. If the fire burns well but sometimes smokes or burns slowly, it may be caused by the chimney top being lower than another part of the house or a nearby tree. The wind blowing over a house or a tree falls on top of the chimney like water over a dam, beating down the smoke. The top of the chimney should be at least 3 feet above the roof and be at least 2 feet higher than any point of the roof within 10 feet (Fig. 6).

NOTE

A draft reading of .05 to .06 W.C. is suggested for proper burning of this unit when using wood or bituminous coal as fuel. When using anthracite coal, this draft reading is a minimum reading.

chimney maintenance

Creosote - Formation and Need for Removal

When wood is burned slowly, it produces tar and other organic vapors, which combine with expelled moisture to form creosote. The creosote vapors condense in the relatively cool chimney flue of a slow-burning fire. As a result, creosote residue accumulates on the flue lining. When ignited this creosote makes an extremely hot fire.

When coal is burned, the products of combustion combine with moisture to form a soot residue which accumulates on the flue lining. When ignited, this soot makes an extremely hot fire.

The chimney should be inspected at least twice monthly during the heating season to determine if a creosote or soot build up has occurred.

If creosote or soot has accumulated, it should be removed. Failure to remove creosote or soot may cause a house fire. Creosote may be removed by using a chimney brush or other commonly available materials.

Chimney fires burn very hot. If the chimney catches fire, immediately call the fire department, then reduce the fire by closing the inlet air control. Pour a large quantity of coarse salt, baking soda or cool ashes on top of the fire in the firebox.

CAUTION

A chimney fire may cause ignition of wall studs or rafters which you thought were a safe distance from the chimney. If you have a chimney fire, have your chimney inspected by a qualified person before using again.

repair parts

SEARS AUTOMATIC COAL OR WOOD BURNING
CIRCULATOR MODEL NO. - 143.840825

Key No.	Part No.	Description
1	85339	Label, Cabinet Panel
2	89175	Knob, Thermostat
3	89176	Handle, Cabinet Front (2 Req'd.)
4	67758	Cabinet Left End
5	21593	Hinge Support
6	83833	Hinge Clip
7	67757	Cabinet Top
8	21063	Back Brace
9	86246	Thermostat Linkage Wire
10	67514	Cabinet Back
11	89065	Hinge (4 Req'd.)
12	67760	Cabinet Door
13	89062	Door Knob
14	83033	Machine Screw (8-32 x 1/4")
15	83005	Machine Screw (10-24 x 1/2")
16	83093	Spring Latch
17	83244	Nut (10-24 PLN, Keps)
18	67759	Cabinet Door Frame
19	67743	Thermostat
20	86191	Thermostat Linkage
21	67753	Cabinet Front

repair parts

SEARS AUTOMATIC COAL OR WOOD BURNING
CIRCULATOR MODEL NO. - 143.840825

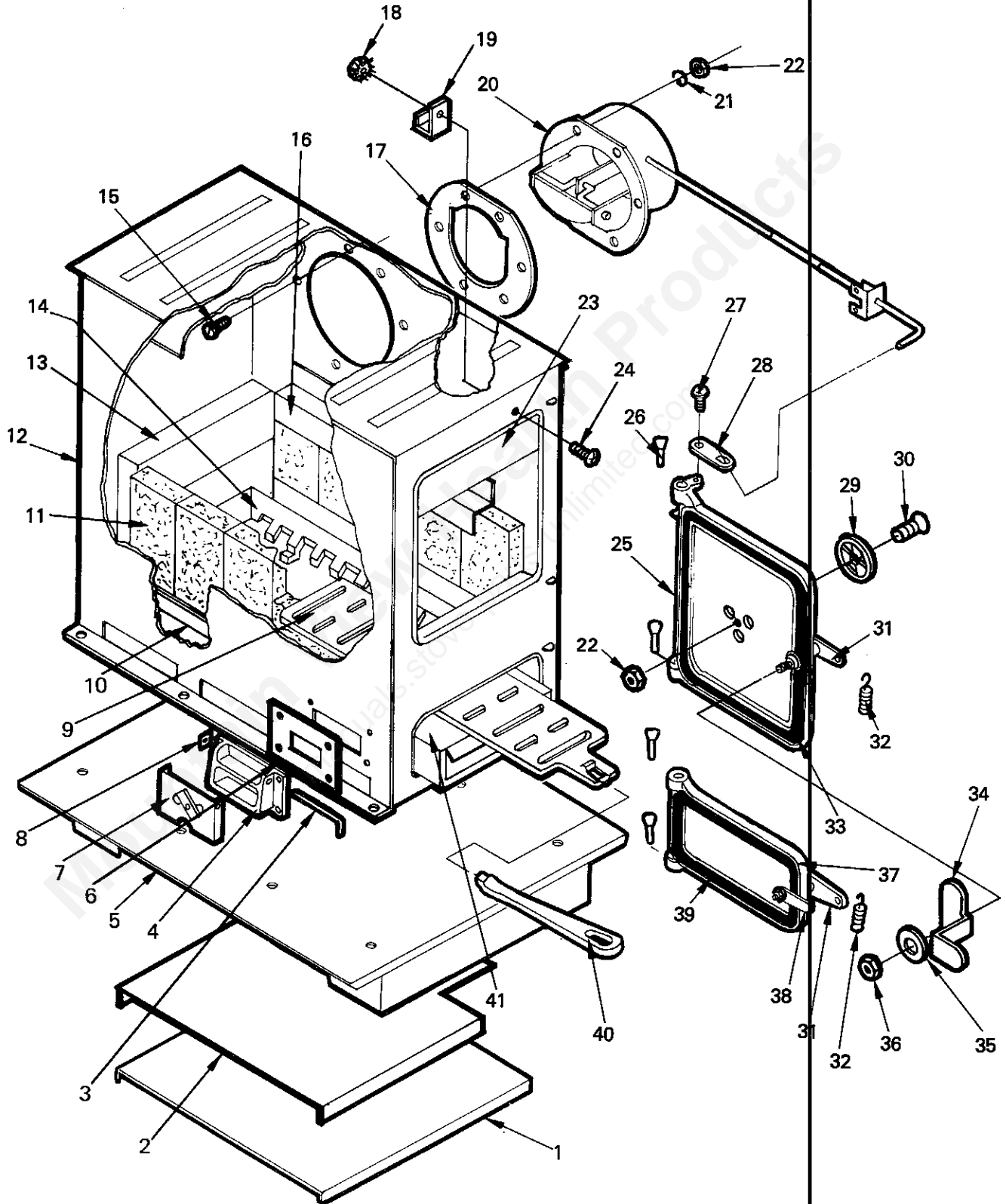

repair parts

SEARS AUTOMATIC COAL OR WOOD BURNING
CIRCULATOR MODEL NO. 143.840825

Key No.	Part No.	Description
1	22110	Shield, Heat
2	67806	Shield, Second Heat
3	17200	Pin, Draft Damper Hinge
4	40075	Frame, Draft Damper
5	67859	Base
6	22029	Plate, Throttle
7	67668	Damper, Draft Control
8	83818	Clip (3 Req'd.)
9	40101	Grate, Coal
10	40130	Grate, Support (5 Req'd.)
11	89066	Firebrick (10 Req'd.)
12	67780	Firebox
13	40100	Liner (3 Req'd.)
14	40102	Frame, Coal Grate
15	83227	Screw, Machine 1/4-20 x 1" Slotted Flat Head (6 Req'd.)
16	40132	Retainer, Firebrick (2 Req'd.)
17	88051	Gasket, Flue Collar
18	83250	Nut, Keps 1/4-20 (2 Req'd.)
19	22171	Bracket, Smoke Curtain (2 Req'd.)
20	67672	Collar, Flue
21	83002	Washer, Lock, 1/4" (7 Req'd.)
22	83072	Nut, 1/4-20 Hex (7 Req'd.)
23	22090	Curtain, Smoke
24	83035	Screw, Machine, 1/4-20 x 1/2" Phillips Truss Head (2 Req'd)
25	22103	Door, Feed
26	83114	Rivet (4 Req'd.)
27	83051	Screw, Machine, 10-24 x 1/2" Phillips Truss Head
28	21842	Arm, Control Rod
29	40056	Wheel, Draft
30	83105	Screw, Machine, 1/4-20 x 1-1/2" Slotted Flat Head
31	21810	Handle, Door (2 Req'd.)
32	67567	Handle, Wood (2 Req'd.)
33	21804	Gasket, Rope Feed Door
34	22434	Latch, Two-Step
35	83045	Washer, Flat, 5/16"
36	83261	Locknut (1/4 - 20 Jam Top) (2-Req'd.)
37	40187	Door, Ash
38	22108	Latch
39	21803	Gasket, Rope Ash Door
40	40045	Shaker
41	67444	Pan, Ash
*	67848	Feed Door (Includes handle and gasket)
*	67781	Ash Door (Includes handle and gasket)
*	85337F	Owner's Manual (F642-8685)

* Not Shown

Sears

**owners
manual
service**

**MODEL NUMBER
143.840825**

**HOW TO ORDER
REPAIR PARTS**

**TELL SEARS YOU
WANT IT INSTALLED -
THEN RELAX**

AUTOMATIC COAL OR WOOD BURNING CIRCULATOR HEATER

Now that you have purchased your Automatic Coal or Wood Circulator heater should a need ever exist for repair parts or service, simple contact any Sears Service Center. Be sure to provide all pertinent facts when you call or visit.

The Model Number will be found on a plate mounted on the back of the heater. Always mention the Model Number when requesting service or repair parts for your Heater.

WHEN ORDERING REPAIR PARTS, ALWAYS GIVE THE FOLLOWING INFORMATION AS SHOWN IN THIS LIST.

1. The PART NUMBER
2. The PART DESCRIPTION
3. The MODEL NUMBER: 143.840825
4. The NAME OF ITEM:

**Automatic Coal or Wood Burning
Circulator Heater**

If the part you need is not stocked locally, your order will be transmitted to a Sears Repair Parts Distribution Center for quick handling.

When Sears arranges the installation, you can be sure the job is done right. We will arrange for professional workmanship. . . and we'll take care of the entire project. What's more, during installation you get insured protection . . . against property damage and also against accidents to workmen. All you have to do is talk to your Sears salesperson or call your nearest Sears store today for detailed information.