

4600

FIGURE 8

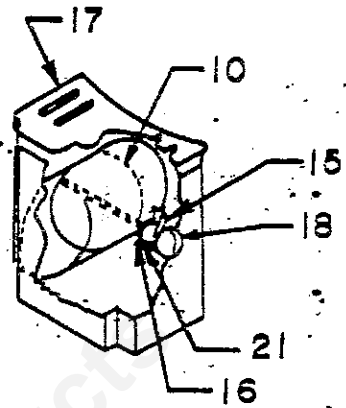
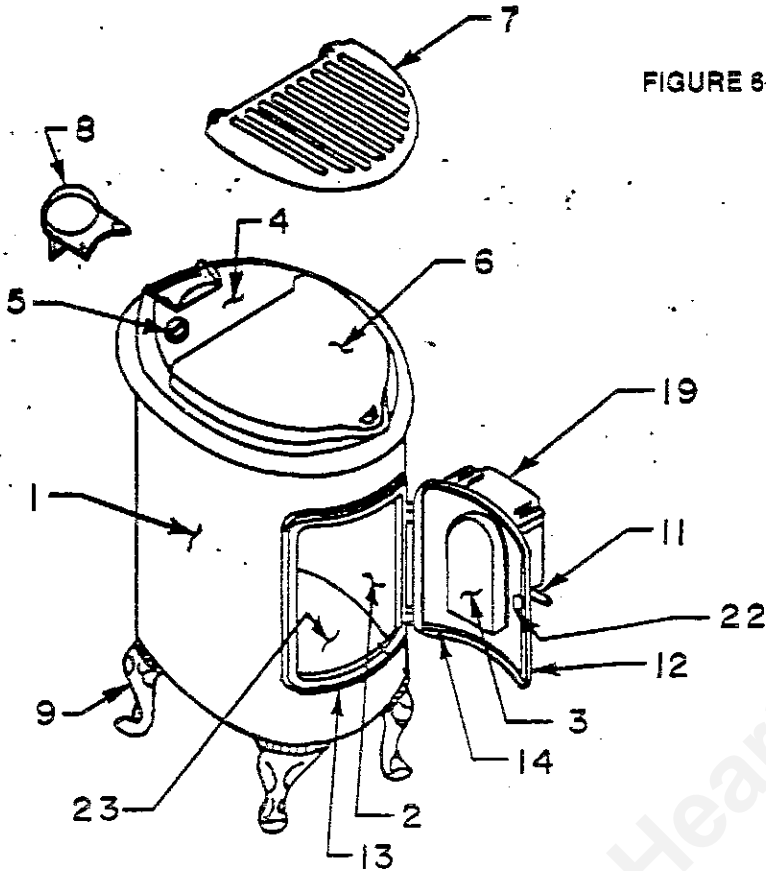

ORDER ALL REPAIR PARTS FROM YOUR KING DEALER
BY SUPPLYING THE FOLLOWING INFORMATION:

1. PART NAME
2. PART NUMBER (Not Key No.)
3. MODEL NUMBER

KEY NO.	DESCRIPTION	PART NO.	UNIT WEIGHT	KEY NO.	DESCRIPTION	PART NO.	UNIT WEIGHT
1	Body w/Bottom only	002859	10 lbs.	13	Feed Door Frame	005150	5-1/2 lbs.
2	Liner	003278	14 lbs.	14	Rope, Fiberglass	013423	49-3/4 in.
3	Draft Plate	005148	4 lbs.	15	Crank, Arm	P5280	3 oz.
4	Top, Main	005153	16-1/2 lbs.	16	Spring, Thermostat	002828	2 oz.
5	Register, Top	005140	1 oz.	17	Thermostat Case	003263	1 lb.
6	Top, Swing	005152	10-1/2 lbs.	18	Knob, Thermostat	002827	2 oz.
7	Grille, Top	003130	3-3/4 lbs.	19	Thermostat Complete	002823	1-3/4 lbs.
8	Collar, Reversible	003129	3-1/2 lbs.	20	Spring		2 oz.
9	Feet (4)	003128	2 lbs.	21	Cup Washer		1 oz.
10	Ring Damper Assembly	002830	4 oz.	22	Latch, Cast	P5236	3 oz.
11	Handle Complete	002821	8 oz.	23	Bottom	003280	3 lbs.
12	Feed Door & Rope Assembly	009158	9-1/2 lbs.				

PURCHASE LOCALLY

