

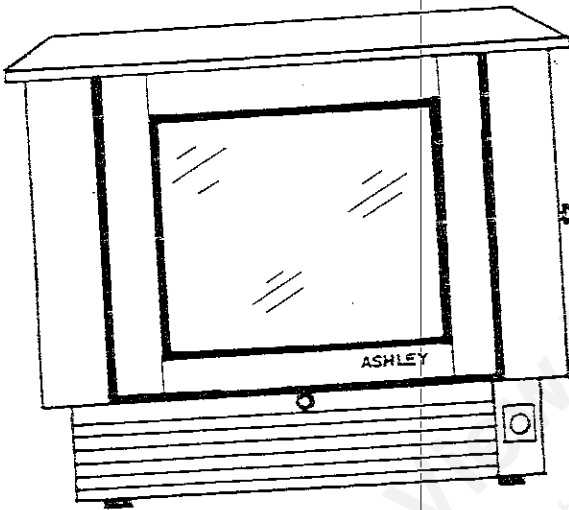

OWNER'S MANUAL

Installation, Operation and Maintenance Instructions
**SAHARA CATALYTIC CIRCULATOR HEATER
MODELS AHS1 (GRAY) AND AHS1B (BROWN)
FOR USE WITH SOLID WOOD FUEL ONLY**



TESTED TO UL1482 AND CERTIFIED
BY
WARNOCK HERSEY INTERNATIONAL, INC.

IMPORTANT GENERAL INFORMATION

- READ ALL INSTRUCTIONS BEFORE STARTING THE INSTALLATION.
- FAILURE TO FOLLOW SAFETY INSTRUCTIONS MAY RESULT IN PROPERTY DAMAGE, BODILY INJURY, OR EVEN DEATH.
- SAVE MANUAL FOR FUTURE REFERENCE.

SAFETY NOTICE

If this heater is not properly installed, a house fire may result. For your safety, follow the installation directions. Contact local building or fire officials about restrictions and installation inspection requirements in your area.
This heater must be connected to a Listed Factory-Built Residential Type and Building Heating Appliance Chimney or an approved masonry chimney with a flue liner.

MANUFACTURED BY: THE ASHLEY HEATER COMPANY
A DIVISION OF MARTIN INDUSTRIES, INC.
P.O. BOX 128
FLORENCE, AL 35631
PH NO. 205/767-0330

AHS1-AHS1B

SUMMARY OF RULES FOR SAFE INSTALLATION, USE AND CARE

PLEASE READ THIS ENTIRE MANUAL BEFORE YOU INSTALL AND USE YOUR NEW HEATER. FAILURE TO FOLLOW INSTRUCTIONS MAY RESULT IN PROPERTY DAMAGE, BODILY INJURY OR EVEN DEATH.

SAFE INSTALLATION

- 1. Qualified Installer/Codes.** Your heater should be installed only by an experienced wood burning heater installer in strict accordance with this manual. Even though the work is done by a qualified installer, you should be familiar with your installation and be sure the work is done in accordance with this manual. Contact local building or fire officials about restrictions and installation inspection in your area. Make sure the installation meets all local codes and that all needed permits are obtained. Many home fires are caused by too little clearance or improper installation of the venting system. This manual gives necessary information to safely install your heater.
- 2. Dangerous Uses/Locations.** Due to fire risk, do not install this heater in a mobile home, modular home or trailer. Do not install it in a garage or area where any flammable liquids are stored. An explosion or fire could result. Due to risk of persons being injured by contacting the hot surfaces of the heater, locate the heater away from traffic areas such as halls.
- 3. Chimney and Flue Pipe.** This heater must be connected to a separate flue pipe and chimney system vented to the outside. The chimney may be either an approved Class "A" Masonry Chimney or a 6" diameter Listed Factory-Built Residential Type and Building Heating Appliance Chimney. These two chimney types will be described in detail in this manual. The heater must be connected to the chimney using a flue pipe that is at least 24 gauge black or blued steel. Do not use a Class "B" aluminum gas vent pipe for either the flue pipe or the chimney. This is unsafe, is a fire risk, and is prohibited by the National Fire Protection Association. To avoid the risk of fire, masonry chimneys must be at least 4" thick (12" if built of rubble stone) and must have a 5/8" fireclay or stainless steel lining.
Review the seven methods of venting shown by Figure 12 through 18. Follow the method that best suits your home. Failure to vent the heater in accordance with the instructions can result in fire or smoke damage and bodily injury including death.

DANGER: FLUE PIPE (CHIMNEY PIPE) GETS SO HOT IT CAN CATCH YOUR WALL OR CEILING ON FIRE IF NOT PROPERLY INSTALLED. THEREFORE, YOU MUST USE AN APPROPRIATE METHOD TO PASS THROUGH A COMBUSTIBLE WALL TO A CHIMNEY (SEE FIGS. 13, 14, 17, and 18) OR A CHIMNEY SUPPORT OR FINISH SUPPORT PACKAGE TO PASS THROUGH A CEILING (SEE FIGS. 15 and 16). OTHERWISE, THE WALL OR CEILING WILL CATCH FIRE FROM THE HOT FLUE PIPE.

DANGER: DO NOT CONNECT THIS UNIT TO A CHIMNEY FLUE SERVING ANOTHER APPLIANCE. THERE IS A SERIOUS SAFETY RISK IF TWO APPLIANCES OR HEATERS ARE CONNECTED TO THE SAME FLUE.

- 4. Floor Protector.** The heater must be placed on a listed floor protector if the floor is wood or other combustible flooring. If carpet is present, it must be removed. Place the heater on a listed floor protector or a floor protector made of a noncombustible, inorganic material equal to 3/8 inch thick millboard having a thermal conductivity of $K = 0.84 \text{ BTU}/\text{In}/\text{Ft}^2/\text{Hr}/^\circ\text{F}$ to prevent the floor from catching fire from sparks or glowing embers that might escape the heater or drop from the joints of the chimney connector pipe. The floor protector must protect the floor beneath and around the heater and chimney connector flue pipe as shown by figures 1 through 5.
- 5. Safe Clearances.** To prevent wall or ceiling fires, ALWAYS maintain the designated clearance dimensions to combustible walls or combustible ceilings as noted for each type of heater installation shown by Figures 12 through 18. Failure to observe these clearances can cause walls or ceilings to catch fire. All other combustible items: (drapes, furniture, clothing, etc.) should be kept even further away from the heater to avoid a fire. NFPA 211 defines combustible material as material made of or surfaced with wood, compressed paper, plant fibers, plastics, or other material that will ignite and burn, whether flameproofed or not, or whether plastered or unplastered.
- 6. Hot Surfaces.** Keep children away from the heater. Do not touch the heater until it is cool to avoid burns.
- 7. Smoke Detector.** Install a smoke detector on each floor of your home. In case of accidental fire it can provide time to escape.
- 8. Inspection After Installation, But Before Use.** Have the entire installation inspected by the local fire department, building code inspector or fire marshal to be sure your installation is safe. Have this manual on hand for a reference if needed. Keep the manual in a safe place where it can be found when needed.

SAFE USE

- 1. Dangerous Fuels.** This heater is designed to burn only natural wood. (See the "Wood Facts" section of this manual for additional information about wood.) This heater is not designed to burn artificial logs, processed fuels, coal, charcoal, plywood, trash, garbage, wrapping paper, preformed wood, or treated wood. These prohibited fuels may cause the heater and chimney to dangerously overheat or release poisonous gases into the dwelling. These prohibited fuels also contain elements such as lead, zinc and sulfur that will "poison" or deactivate the catalytic combustor. A poisoned catalytic combustor will not operate effectively and must be replaced.

Never use gasoline, gasoline type lantern fuels, kerosene, charcoal lighter fluid, or any similar liquids to start or freshen up a fire in this heater. The use or presence of these type fuels in or around the heater can cause an explosion and house fire resulting in personal injuries and property damage.

4. Keep furniture, drapes, curtains, wood, paper, and other combustibles far away from the heater.
5. Never install the heater in locations where gasoline, kerosene, charcoal lighter, or any other flammable liquids are used or stored.
6. DO NOT INSTALL THIS HEATER IN A MOBILE HOME, MODULAR HOME OR TRAILER.

TOOLS AND SUPPLIES NEEDED FOR INSTALLATION

Pencil	Electric drill	Rag or several paper towels
Ruler or tape	Drill bits	No. 8 sheet metal screws
Tin snips	Screwdriver	(3 each for each joint of chimney connector pipe)
Adjustable wrench	Furnace cement	

INSTALLATION EQUIPMENT NEEDED FOR YOUR SAFETY

1. Chimney Connector: (Also known as flue pipe or stove pipe) - The chimney connector joins the heater to the chimney. The chimney connector should be 6-inch diameter black or blued steel, 24 gauge minimum.
2. Thimble: A manufactured or site-constructed device installed in combustible walls through which the chimney connector passes to the chimney. It is intended to keep walls from igniting. A thimble is needed only if chimney connector must pass through a combustible wall between the heater and the chimney.
3. Chimney (Approved Masonry Chimney or a Listed Factory-Built Residential and Building Heating Appliance Chimney):
A Masonry Chimney (constructed to the National Fire Protection Association and local code standards) with at least 5/8-inch fire clay lining joined with refractory cement or other listed lining system suitable for use with wood burning heaters. See the "MASONRY CHIMNEY REQUIREMENTS" section of this manual for masonry chimney specifications.

OR

A prefabricated 6-inch diameter Listed Factory-Built Residential and Building Heating Appliance Chimney. Associated components required for installation such as the chimney support base, firestop (as appropriate), attic insulation shield, insulated tee, etc., are necessary to assure a safe chimney installation. Use only components manufactured for the chimney.

AVOID FIRE: Maintain the designated clearance distance to combustibles. Insulation must NOT touch the chimney. There must be the designated air space clearance around the chimney. This air space around a chimney is necessary to allow natural heat removal from the area. Insulation in this space will cause a heat buildup which may ignite wood framing.

4. Floor Protector: To prevent floor from catching fire, a listed floor protector or a floor protector made of a noncombustible inorganic material equal to 3/8-inch thick millboard having a thermal conductivity of $K = 0.84 \text{ BTU/In/Ft}^2/\text{Hr}/^\circ\text{F}$ must be used. Depending on the type of heater installation you use, the floor protector must protect the floor beneath and beyond the heater and chimney connector pipe as shown by figures 1 through 5.

WARNING: MINIMUM CLEARANCES AND FLOOR PROTECTOR SHOWN BY FIGURES 1 THROUGH 5 ARE TO PREVENT WALLS AND FLOOR FROM CATCHING FIRE. MINIMUM CLEARANCES TO CEILING TO PREVENT THE CEILING FROM CATCHING FIRE ARE SHOWN BY FIGURES 13, 14, 17, and 18.

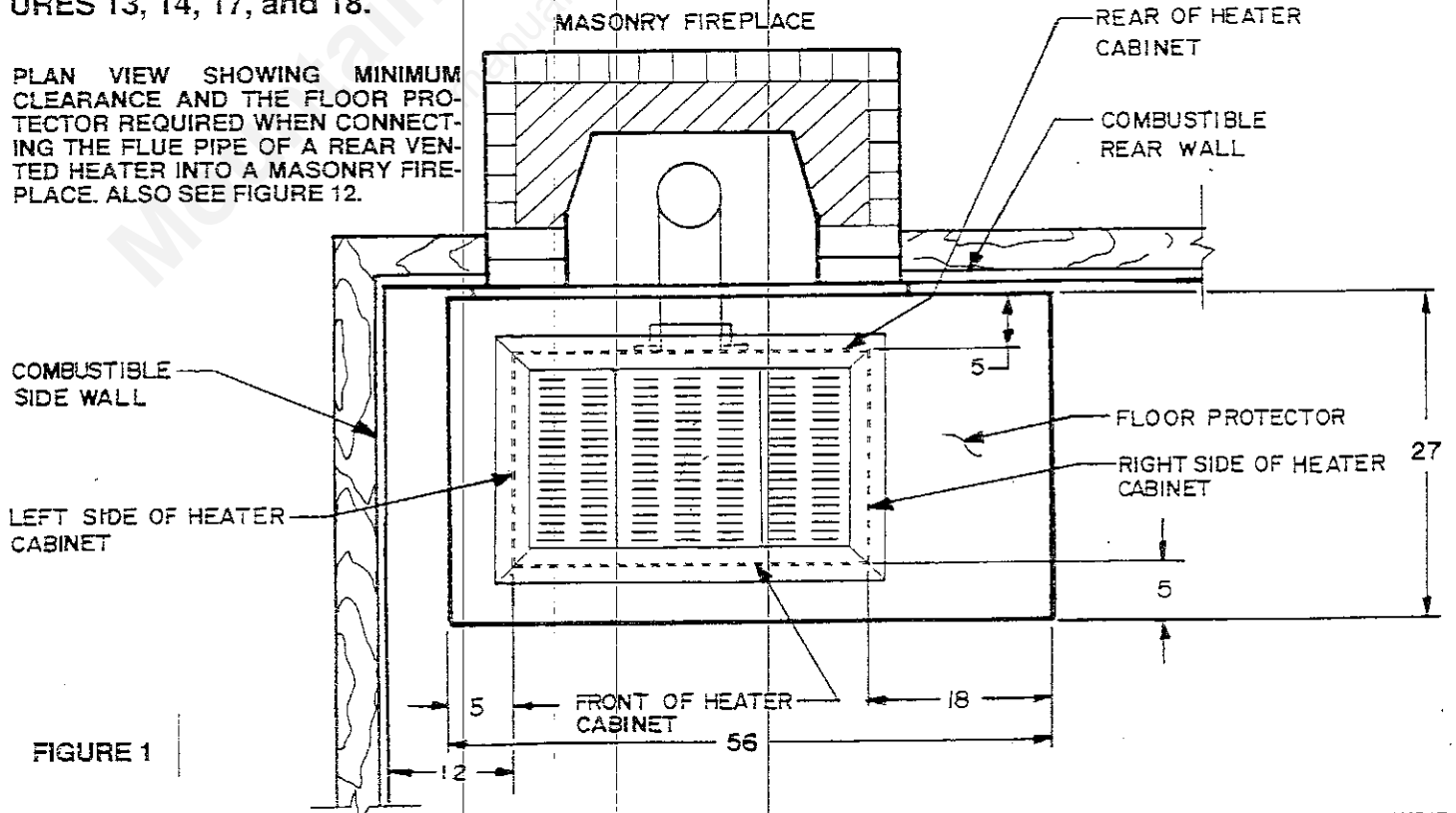

FIGURE 1

FIGURE 4

PLAN VIEW SHOWING MINIMUM CLEARANCE AND THE FLOOR PROTECTOR REQUIRED WHEN CONNECTING THE FLUE PIPE OF A TOP VENTED HEATER TO A MASONRY CHIMNEY THROUGH A COMBUSTIBLE WALL OR WHEN CONNECTING THE FLUE PIPE OF A TOP VENTED HEATER TO A LISTED RESIDENTIAL TYPE AND BUILDING HEATING APPLIANCE CHIMNEY THROUGH A COMBUSTIBLE WALL FOR AN OUTSIDE INSTALLATION. ALSO SEE FIGURES 14 AND 18.

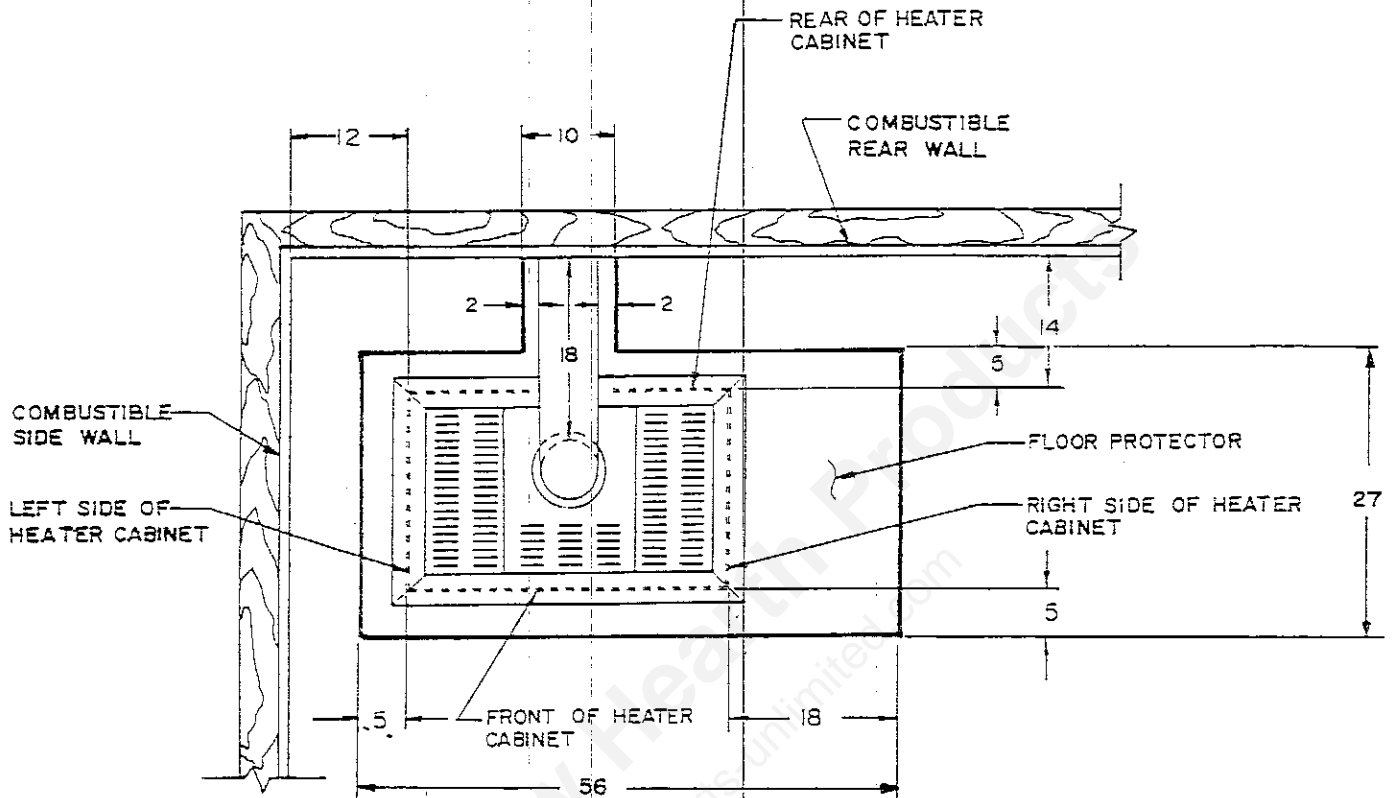
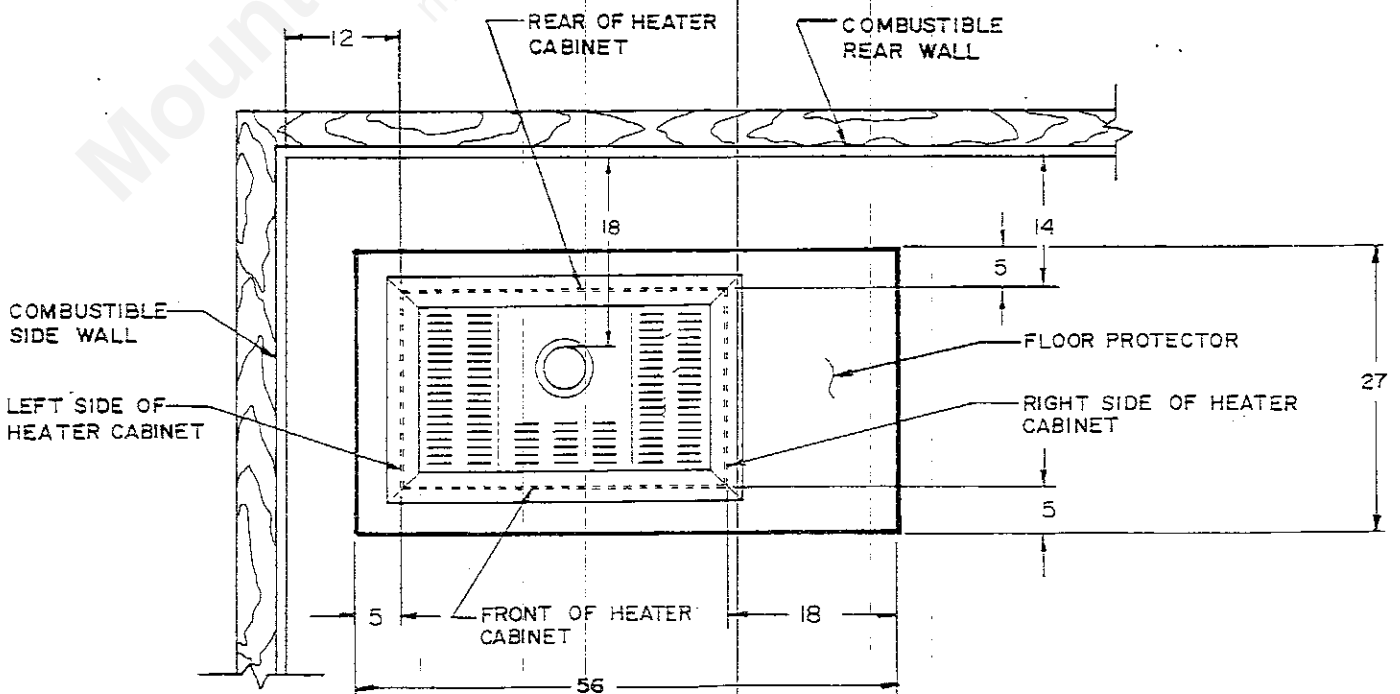

FIGURE 5

PLAN VIEW SHOWING MINIMUM CLEARANCE AND THE FLOOR PROTECTOR REQUIRED WHEN CONNECTING THE FLUE PIPE OF A TOP VENTED HEATER TO A LISTED RESIDENTIAL TYPE AND BUILDING HEATING APPLIANCE CHIMNEY THROUGH A COMBUSTIBLE CEILING AND A COMBUSTIBLE ROOF FOR AN INSIDE INSTALLATION. ALSO SEE FIGURE 16.



Should you choose a venting system installation for a top vented heater, you will have to convert the heater for top venting before proceeding.

The following procedure should be followed when converting a rear vented heater to a top vented heater (Refer to figure 6.)

1. Be sure the heater's blower power supply cord (Key No. 1) is unplugged.
 2. Remove the louvered top assembly (Key No. 2) by lifting it up and out of the top frame assembly (Key No. 3).
 3. Remove the top frame assembly (Key No. 3) from the heater by removing the two screws, washers, and nuts which secure it to the heater's firebox top (Key No. 4).
 4. Remove the heater's left cabinet side (Key No. 5) by lifting it upward while pulling it toward the left. It will snap loose.
 5. Remove the spring handle (Key No. 6) from the bypass damper control lever by turning the spring handle counterclockwise while pulling on it.
 6. Remove the rear cabinet assembly (Key No. 7) by removing the six nuts and washers which attach the rear cabinet assembly to the firebox. There are three nuts and washers attaching the rear cabinet assembly to the right rear of the firebox and there are three nuts and washers attaching the rear cabinet assembly to the left rear of the firebox.
NOTE: The rear cabinet assembly (Key No. 7) includes the rear cabinet, the cabinet door assembly and the blower shroud through which the blower's power cord passes.
- CAUTION: When removing the rear cabinet assembly, (Key No. 7) from the heater and lying it flat in the floor, care should be taken not to damage nor loosen any of the power supply cord's internal wiring.
7. Remove the flue collar and its gasket attached to the rear of the firebox by removing the flue collar's eight flathead attachment screws. Care should be taken not to damage the flue collar gasket.
 8. Remove the firebox cover plate (Key No. 8) and its gasket attached to the top of the firebox by removing the cover plate's eight hex head attachment screws. Care should be taken not to damage the firebox cover plate gasket.
 9. Use the flue collar's eight flathead attachment screws to securely attach the flue collar and its gasket to the top of the firebox where the firebox cover plate (Key No. 8) was previously attached. Care should be taken to ensure an airtight seal between the flue collar, the flue collar gasket, and the firebox top.
 10. Use the firebox cover plate's eight hex head attachment screws to securely attach the firebox cover plate (Key No. 8) and its gasket to the rear of the firebox where the flue collar was previously attached. Care should be taken to ensure an airtight seal between the firebox cover plate, the firebox cover plate gasket, and the rear of the firebox.
 11. Reattach the rear cabinet assembly (Key No. 7) removed by Step 6.

CAUTION: When reattaching the rear cabinet assembly to the firebox, care should be taken not to damage nor loosen any of the power supply cord's internal wiring.

12. Reattach the spring handle (Key No. 6) to the bypass damper control lever by turning the spring handle counterclockwise while pushing it onto the lever.
13. Reattach the left cabinet side (Key No. 5) by positioning it in place, pulling up on its top flange while pushing it into place. The left cabinet side will snap snugly into place.
14. Reattach the top frame assembly (Key No. 3) to the firebox top (Key No. 4). Care should be taken because the same two screws, washers, and nuts which secure the top frame assembly to the firebox top also secures the heater's flame impingement shield inside the heater's firebox.
15. Use the two screws (Key No. 9) provided in the top vent conversion kit furnished with the heater to attach the rear cabinet cover plate (Key No. 10) over the vacated flue collar hole in the rear cabinet.
NOTE: The rear cabinet cover plate (Key No. 10) is provided in the top vent conversion kit furnished with the heater.
16. Replace the center louvered top (key No. 11) in the louvered top assembly (Key No. 2) with the center louvered top (Key No. 12) which has a hole for the flue collar to protrude through. This may be accomplished as follows:
First - Loosen the set screws which hold the louvered top assembly together.
Second - Replace the center louvered top.
Third - Reassemble the louvered top assembly containing the center louvered top (Key No. 12) which has a hole for the flue collar to protrude through. Be sure to securely retighten any set screws previously loosened.
NOTE: The center louvered top (Key No. 12) which has a hole for the flue collar to protrude through is provided in the top vent conversion kit furnished with the heater.
17. Place the assembled louvered top assembly into the cavity of the top frame assembly (Key No. 3).

HEATER INSPECTION

Before installing the heater, check the heater for external damage or missing parts. Check the glass for any cracks. Turn the blower control knob to HIGH and place the power supply cord into a 120 volt, 60 Hz, 15 amp properly fused and grounded receptacle and check the operation of the blower. Check inside the heater for damaged or missing parts.

If any damage or missing parts are detected, report it to the dealer from whom you purchased the heater and get the deficiency corrected before installing and using the heater.

HEATER INSTALLATION

CAUTION: IF THIS HEATER IS NOT PROPERLY INSTALLED, A HOUSE FIRE MAY RESULT. FOR YOUR SAFETY, FOLLOW THE INSTALLATION DIRECTIONS. CONTACT LOCAL BUILDING OR FIRE OFFICIALS ABOUT RE-

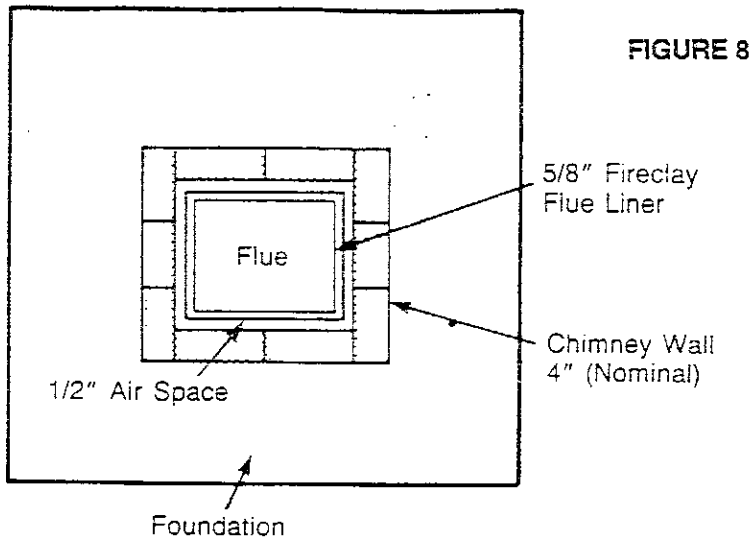

FIGURE 9

*Minimum 1 Inch Clearance for Exterior Chimney to Sheathing

FIRESTOPPING

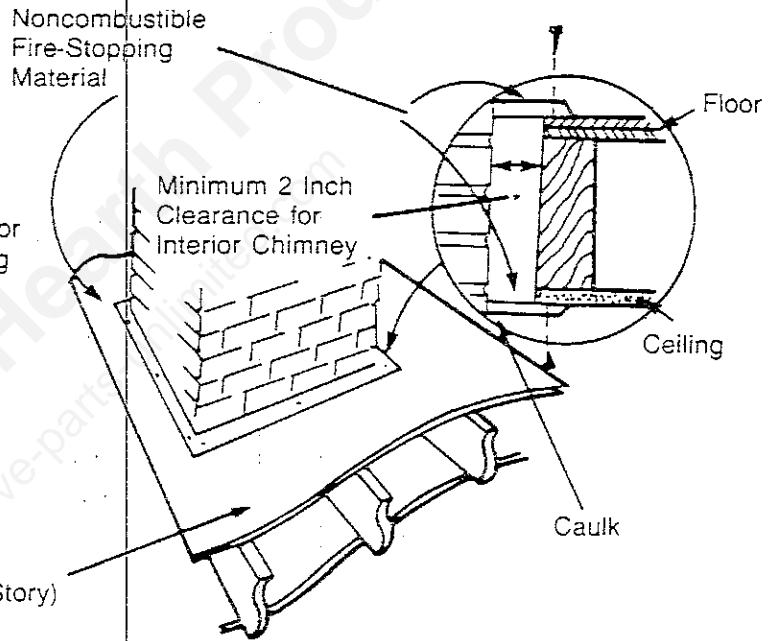

FIGURE 10

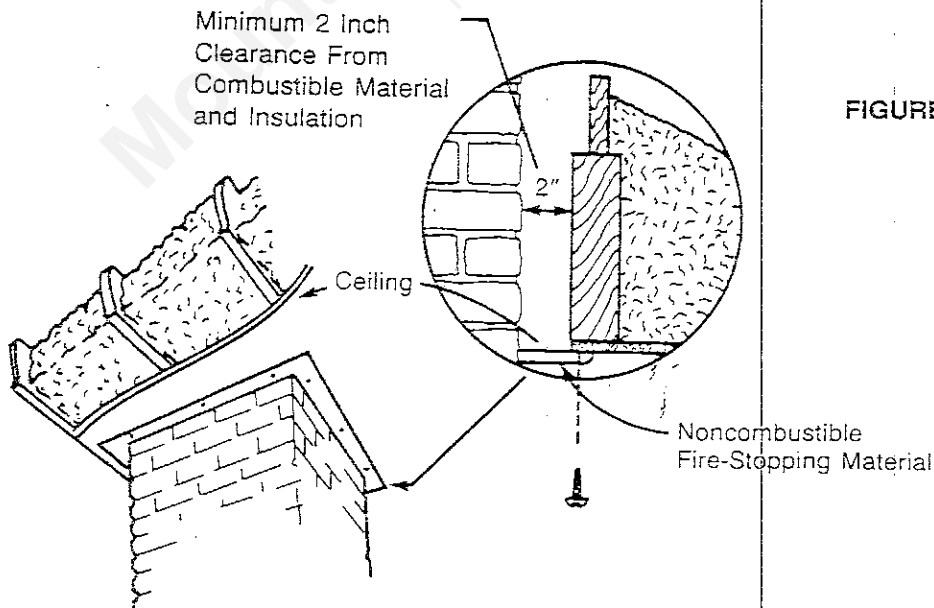
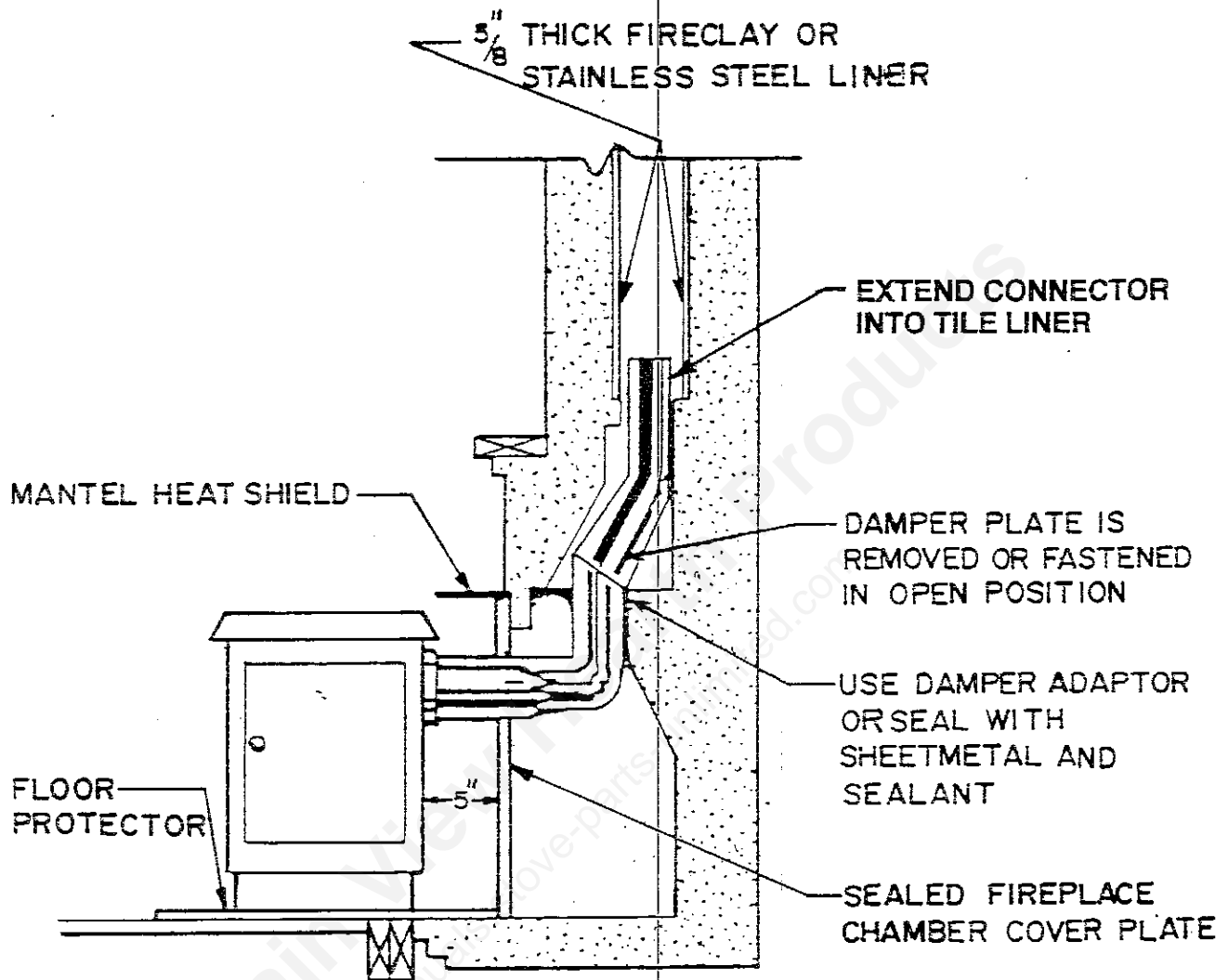

FIGURE 12



CONNECTION OF FLUE PIPE TO A MASONRY CHIMNEY THROUGH A COMBUSTIBLE WALL

Figure 13 shows how to connect the flue pipe of a rear vented heater to a masonry chimney through a combustible wall. Figure 14 show how to connect the flue pipe of a top vented heater to a masonry chimney through a combustible wall. There are four allowable ways that a flue pipe can be connected to a masonry chimney by passing through a combustible wall. NFPA 211 allows the following:

1. Use a 3 1/2" thick brick wall built into a combustible wall. A fireclay thimble must be used and it must be at least 12" away from any material that could catch fire. See and study part A of Figure 13 or Figure 14.
2. Use an 8" inside diameter, Listed 1" solid insulation, factory-built chimney. The chimney section must be at least 12" long. The chimney section serves as a pass-through tube for the 6" 24 ga. chimney connector. Steel supports at the ends of the chimney section must hold the 6" pipe 1" away from the inside wall of the chimney section. The chimney section must be at least 2" away from any material that could catch fire. It also must be supported by at least 24 ga. steel supports firmly attached to the wall surface on both sides of the wall. See and study part B of Figures 13 and 14.
3. Use a ventilated thimble, at least 24 ga. steel with two 1" air channels. This means the thimble must be 10" in diameter. The thimble must be surrounded by glass fiber insulation 6" thick. Two 24 ga. wall supports are used to keep 6" between the outer wall of the thimble and any material that can catch fire. The supports must be firmly attached on both sides of the wall. See and study part C of Figures 13 and 14.
4. Use a 6" inside diameter, listed 1" solid insulation, factory-built chimney. The chimney section must be at least 12" long. The chimney section must be 9" away from any material that can catch fire. The section must be supported by 24 ga. steel supports firmly attached to both sides of the wall. See and study part D of Figures 13 and 14.

(FIGURE 13 CONTINUED)

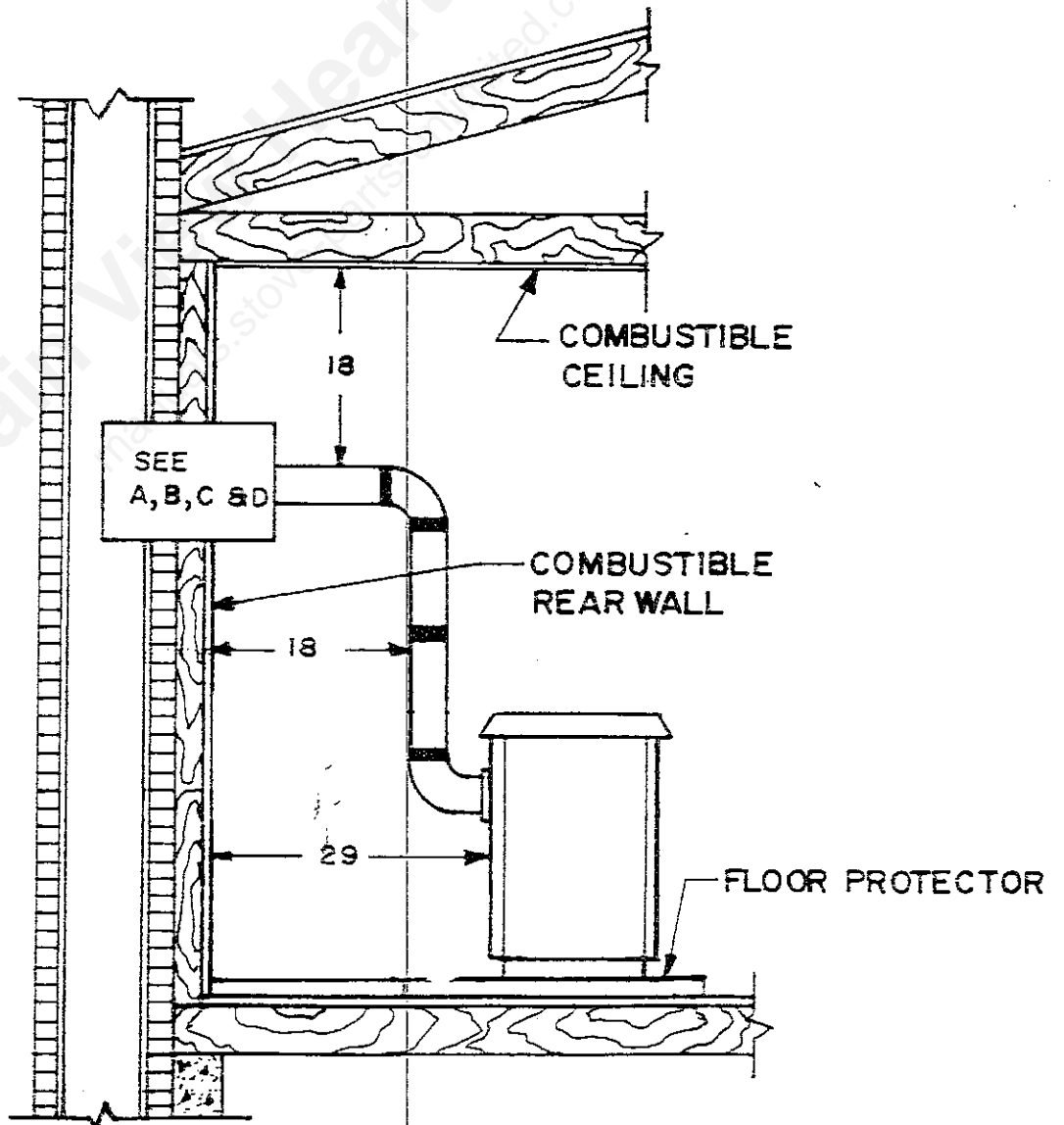
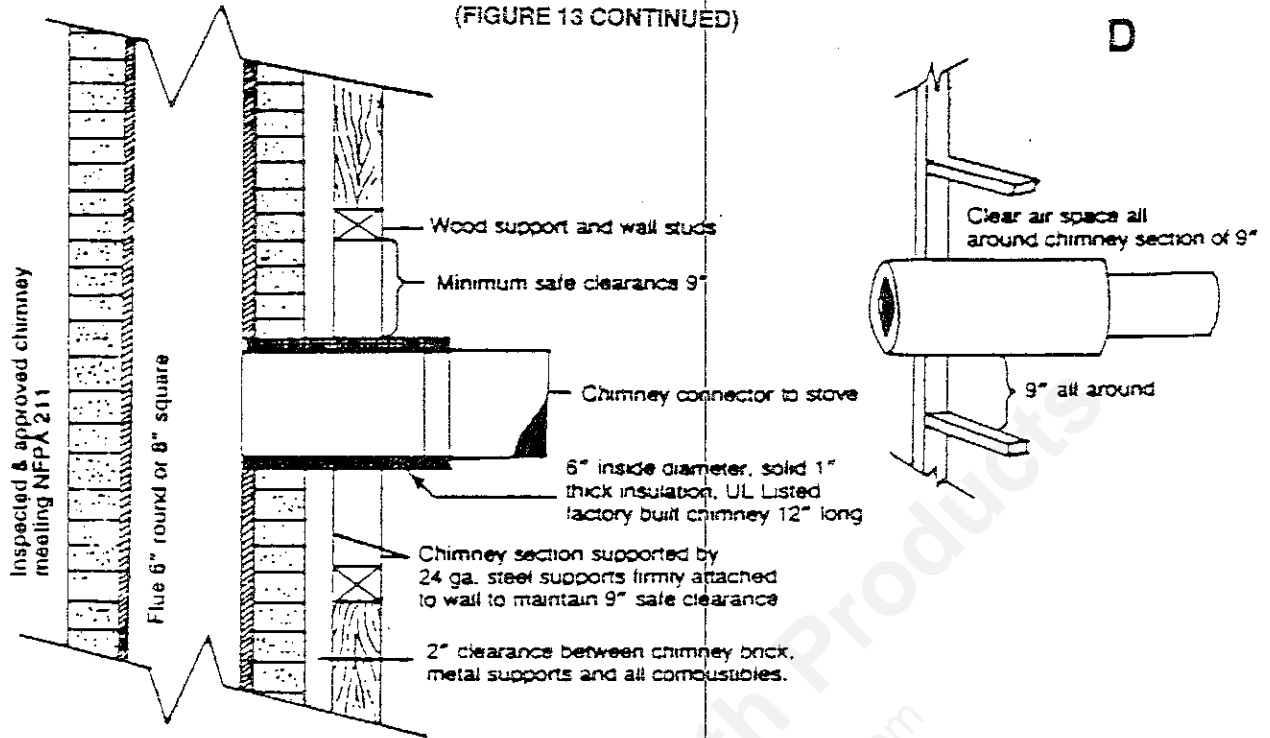

(FIGURE 14 CONTINUED)

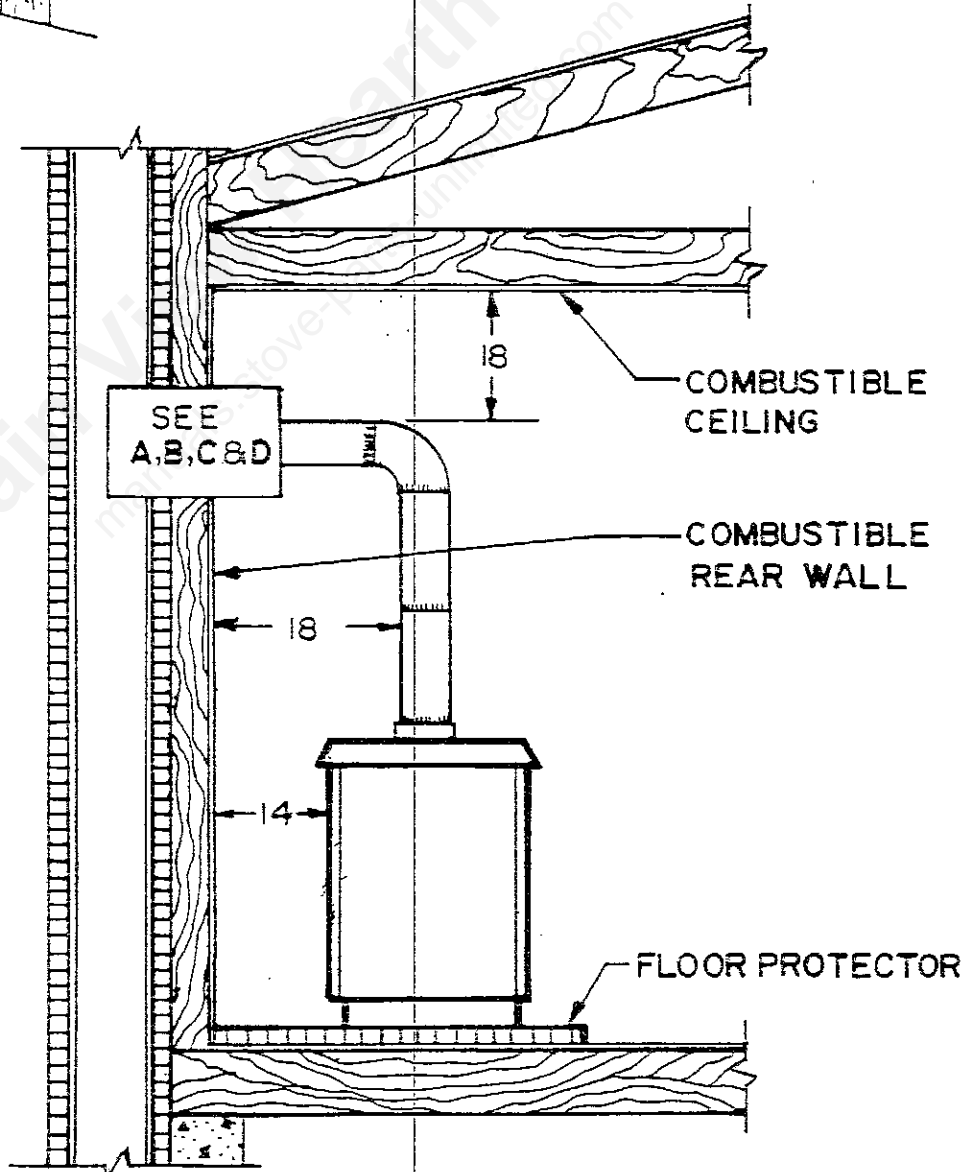
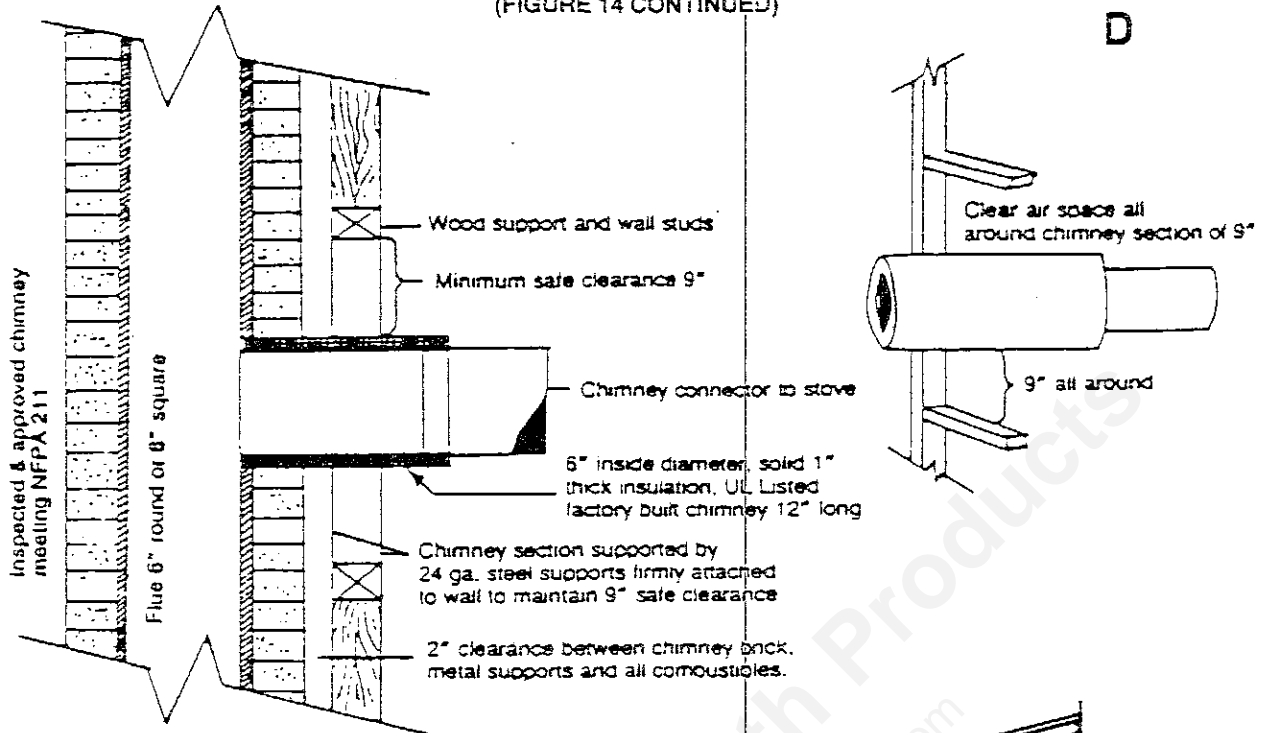
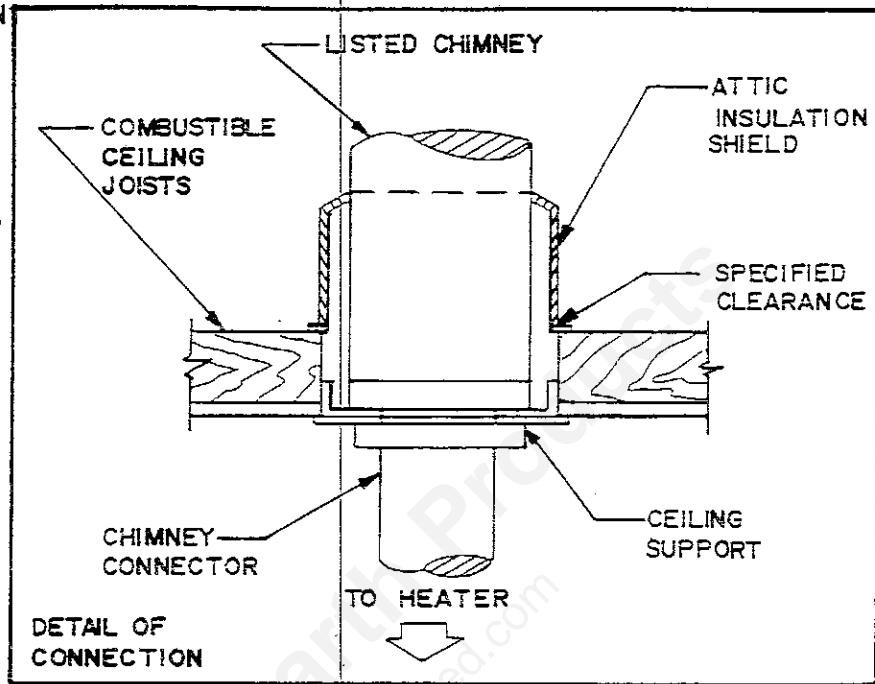

FIGURE 15

CONNECTING THE FLUE PIPE OF A REAR VENTED HEATER TO A LISTED RESIDENTIAL TYPE AND BUILDING HEATING APPLIANCE CHIMNEY INSTALLED INSIDE THE RESIDENCE THROUGH THE CEILING AND THE ROOF. ALSO SEE FIGURE 3.

INSTALL AN ATTIC INSULATION SHIELD TO MAINTAIN THE SPECIFIED CLEARANCE TO INSULATION. INSULATION IN THIS AIR SPACE WILL CAUSE A HEAT BUILDUP WHICH MAY IGNITE THE CEILING JOISTS.



MAINTAIN 2 INCH CLEARANCE

LISTED CHIMNEY

CEILING SUPPORT

CHIMNEY CONNECTOR

FLOOR PROTECTOR

LISTED CAP

STORM COLLAR

ROOF FLASHING

18

29

THIS METHOD OF INSTALLATION REQUIRES AT A MINIMUM A CEILING SUPPORT PACKAGE, A SECTION OF CHIMNEY, AN INSULATION SHIELD, A ROOF FLASHING, AND A CHIMNEY CAP.

COMBUSTIBLE WALL

CONNECTING THE FLUE PIPE OF A REAR VENTED HEATER TO AN EXTERIORLY INSTALLED LISTED RESIDENTIAL TYPE AND BUILDING HEATING APPLIANCE CHIMNEY THATS RUNS UP THE OUTSIDE OF THE RESIDENCE. ALSO SEE FIGURE 2.

FIGURE 17

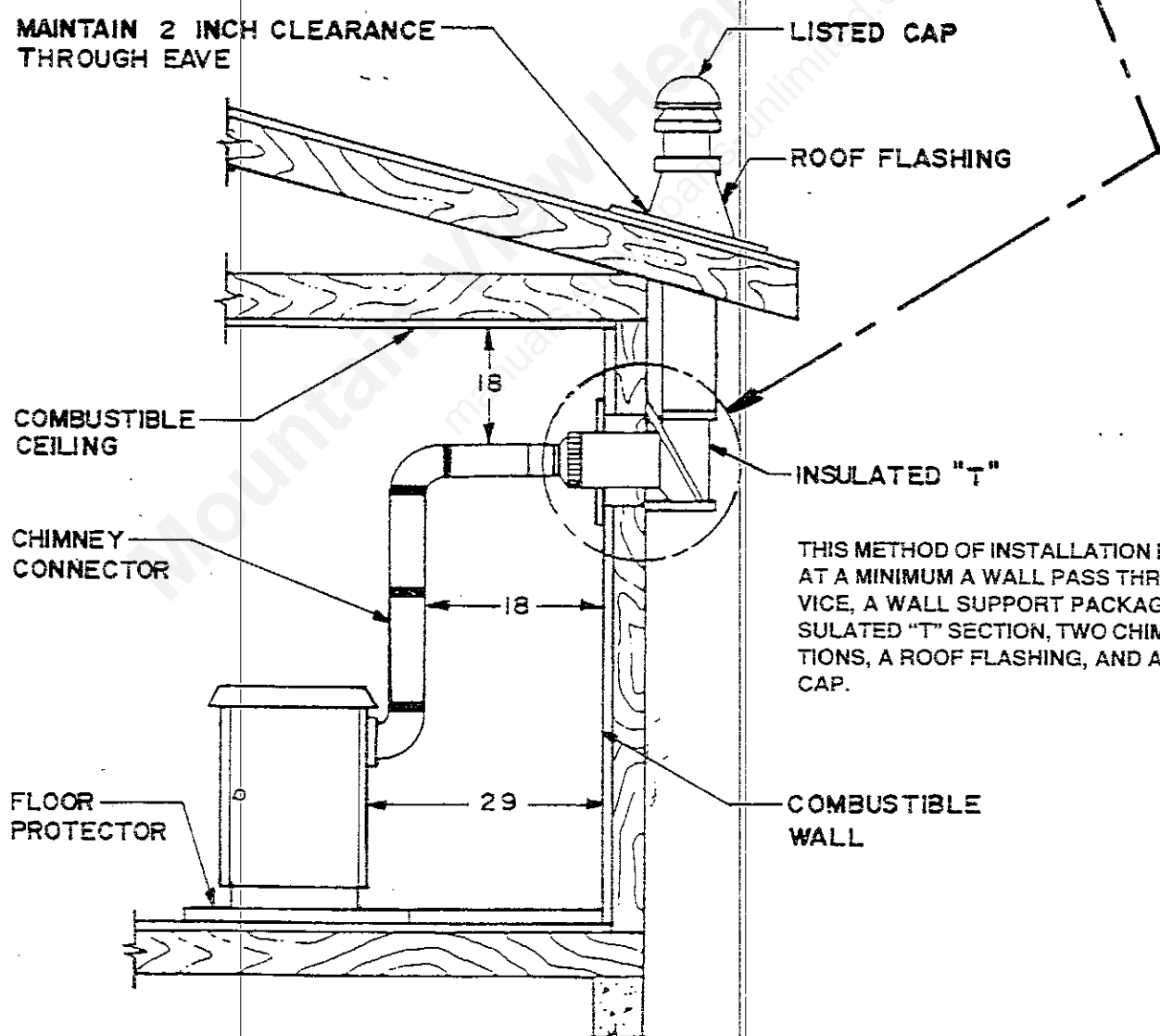
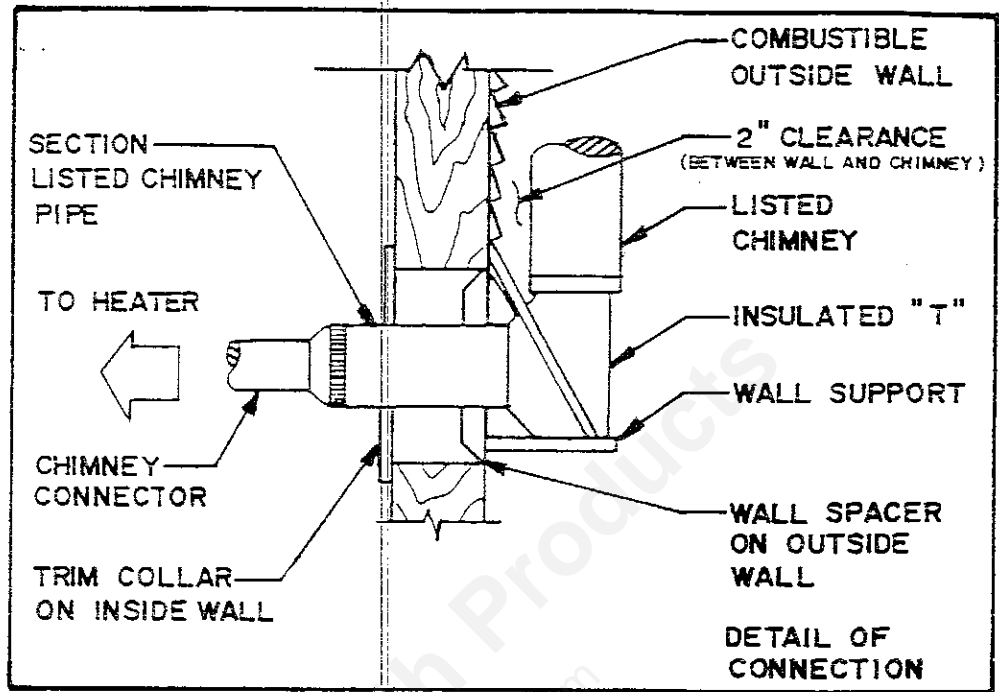

HOW TO USE THE HEATER SAFE OPERATION

IMPORTANT: DO NOT USE THE HEATER UNTIL A PROFESSIONAL INSPECTION HAS BEEN MADE OF THE ENTIRE INSTALLATION BY YOUR LOCAL FIRE DEPARTMENT, FIRE MARSHAL OR BUILDING CODE INSPECTOR. INSTALL A SMOKE DETECTOR ON EACH FLOOR OF YOUR HOME IN CASE OF ACCIDENTAL FIRE FROM ANY CAUSE. IT CAN PROVIDE TIME FOR ESCAPE.

SAFETY REMINDERS

- A correctly installed heater can still pose a fire hazard if it is not used properly.
- Only after the heater is installed properly, attached to an approved chimney in good condition and has been inspected by a qualified person, it is ready for operation.
- Remember not to place any combustibles near the heater. In addition to furniture, rugs and clothing, this includes paper which you might use to start the fire. A hot coal could fall from the heater and cause a fire.
- Never use flammable liquids to start or freshen a fire. Gasoline, kerosene, lantern fuel and other such liquids can explode.
- Don't touch a heater to see if it's hot. Use insulated and fireproof gloves when tending the heater.
- When the heater is operating, children must be closely supervised. Unaware of the potential danger of a hot heater, children may accidentally bump into or touch the heater and be burned.
- Make sure you do not wear loose or flowing garments when tending the heater. Clothing like this could ignite. Be careful that hot coals don't fall on your clothing.
- Open a window to allow fresh air into the room when you use the heater for long periods of time to prevent asphyxiation.
- Do not use this heater as a trash disposal. This can cause dangerous overheating.
- Do not overfire this heater. Overfiring can cause a chimney fire or house fire. Overfiring can also shorten the life of the heater.
- Burn natural wood only in this heater. See the "WOOD FACTS" section of this manual for detailed information. Burning anything other than natural wood in this heater may damage the catalytic combustor.
- The small amounts of wood used for daily fire tending should be kept in a non-combustible container at least 36 inches away from the heater.
- Use only metal containers with tight fitting lids to remove ashes.

WOOD BURNING FACTS

The amount of heat you receive from the heater, the degree of control you have over its heat output, how safely you operate your heater, and how often you have to clean your chimney are all somewhat dependent on how much you know about wood and burning wood. This section is devoted to providing you with a few basic facts about firewood, how to prepare it for use, and how to burn it. For more specific information on how to select and obtain good firewood, write the Superintendent of Documents, U.S. Government Printing Office, Washington, D.C. and request a copy of Forest Service Leaflet No. 559.

The two factors that determine the amount of heat you get from a quantity of wood is its density and moisture content. All species of wood when oven dried and burned will produce approximately 8,600 BTU's per pound of wood, but because hardwoods are more dense than soft woods, a piece of hardwood will produce more heat than a piece of soft wood of equal size and moisture content.

Before wood can burn the water trapped in the wood must be boiled away. As anyone who has ever boiled water knows, it takes a considerable amount of heat to boil even a cup of water until it is all boiled away. Because freshly cut green wood or wet wood may be 50% water by weight a considerable amount of the heat produced by burning green or wet wood is consumed by boiling the water out of the wood before it will burn. For this reason, green or wet wood is likely to produce a smoldering smokey fire and chimney temperatures that are cool enough to cause rapid accumulation of creosote. Burning green or wet wood can also waste up to 50% of the heat you should be getting in your home.

To prepare wood for the most economical and trouble free burning, it should be cut, split, and stacked out of the rain with its ends exposed for at least 6 months before it is burned. Wood that has been "seasoned" in this fashion will normally dry naturally until it is approximately 20% water by weight.

When a wood log is laid on a burning fire, several process take place. First as the temperature of the surface of the logs reaches 212 degrees Fahrenheit, water at the surface begins to boil away. Until most of the water is boiled out of the surface of the log, the log is consuming heat and is not producing any heat. After sufficient water is boiled away and the temperature of the logs surface begins to get hotter, hydrocarbon gases begin to flow out of the wood. These gases will burn if they reach a temperature of 900 to 1100 degrees Fahrenheit and there is sufficient oxygen present in the air around them. This is a critical point in the burning of wood because if there is not enough oxygen present or the area around the log is being cooled by nearby logs that are not burning and only using heat to boil away water, these hydrocarbon gases will go up the chimney unburned. This means a significant amount of the wood's heat value is lost and if these gases cool to 250 degrees Fahrenheit before they get out of the chimney they will condense to form **creosote**.

Your Ashley heater has been designed to burn the wood cleanly but it cannot do so unless you add seasoned wood to the fire in reasonable quantities and leave the combustion air opening open enough to assure a supply of oxygen to the fire. You will get the most out of your wood and your heater if you; add small quantities of wood to the fire frequently rather than large quantities infrequently, keep the fire burning at a rate to assure there is adequate heat to boil away the water and burn the gases, and keep enough air flowing through the heater to burn the quantity of gases being released from the wood. **Remember heavy smoke from a fire means poor use of the wood.**

8. Once the logs begin to burn, securely close the fuel feed door and then the by-pass damper. The by-pass damper is closed when the control rod protruding through the heater's cabinet back is at its innermost position. NOTE: The by-pass damper must be operated manually.

CAUTION: OPERATING THE HEATER WITH THE FUEL FEED DOOR OR THE ASH REMOVAL DOOR OPEN CREATES AN ABNORMAL FIRING CONDITION WHICH CAN OVERHEAT THE HEATER, CHIMNEY AND ADJACENT COMBUSTIBLE MATERIALS. THIS CAN DRASTICALLY SHORTEN THE HEATER'S LIFE, THE CATALYTIC COMBUSTOR'S LIFE, AND VOID THE FACTORY WARRANTIES OF THE HEATER AND ITS COMPONENTS.

9. When all the wood in the firebox is burning well, finish loading the heater in the following sequence:

First - Open the by-pass damper.

Second - Wait about one minute after opening the by-pass damper, then open the fuel feed door.

NOTE: Because the catalytic combustor offers some resistance to the flow of smoke, opening the fuel feed door without first opening the by-pass damper will allow smoke and possibly flames to spill from the heater. ALWAYS OPEN THE BY-PASS DAMPER BEFORE OPENING THE FUEL FEED DOOR AND KEEP IT OPEN WHILE FEEDING WOOD TO THE FIRE. KEEP THE BY-PASS DAMPER CLOSED AT ALL OTHER TIMES FOR MORE EFFICIENT HEATER OPERATION.

Third - Load the firebox with the desired amount of wood.

NOTE: Probably the least understood requirement in maintaining a good fire is that of establishing a good base of coals. Many new heater users hesitate to load enough wood to sustain a fire. A good bed of hot coals will maintain a more even temperature as well as get a new load of wood started burning easily.

Fourth - Securely close the fuel feed door.

Fifth - Close the by-pass damper.

10. Wait about 20 minutes to ensure that the heater, catalytic combustor, and wood are all stabilized at proper operating temperatures, then adjust the inlet air control for the desired heat and burn rate. The proper setting can only be obtained by trial since conditions of fuel, space being heated, individual preference, etc., vary. For most conditions, good results can be obtained by setting the inlet air control lever at its center position. After some experience with the heater, you will learn the best setting for your needs. The more you close the air control, the lower and slower the fire will burn. The more open the inlet air control, the hotter and faster the fire will burn.

Let each load burn down to a good coal bed. Frequent reloading will cause major fluctuations in temperature and wood/air mix, thereby reducing efficiency.

How long a load of wood burns will vary considerably with the variables such as type of wood, how well the wood is seasoned, the inlet air control setting, the position of the heater in the house, and how well the house is insulated.

FIRE TENDING:

Fire tending is the occasional re-positioning of the burning wood to ensure air flow through it and adding new wood as needed. With experience, you should determine how often fire tending is required to maintain the desired heat output of the heater. To ensure safe and satisfactory performance of the heater, the following rules should be observed:

1. KEEP THE ASH AND FEED DOORS CLOSED EXCEPT WHEN TENDING THE FIRE OR REMOVING ASHES. Operating the heater with the doors open can cause the heater to dangerously overheat and increase the possibility of smoke, fire, ash, or sparks escaping the heater and damaging the dwelling or its contents.
2. The following sequence should always be followed when opening the heater's fuel feed door to prevent smoke and possibly fire from spilling out of the heater:
 - a. Fully open the inlet air control.
 - b. Fully open the by-pass damper.
 - c. Wait about one minute, then open the fuel feed door.
3. Never overfill the heater to the point that the by-pass damper is blocked. Overfilling the heater can cause it to overheat, create a fire hazard, and damage the heater.
4. DO NOT OVERFIRE THE HEATER. If the heater or chimney connector glows, you are overfiring the heater. Immediately close any heater door that might be open, completely close the heater's combustion air inlet, (See figure 19). These actions should decrease the fire intensity and allow the heater and chimney connector to cool down. Overfiring can cause a fire hazard and greatly shorten the life of the heater.
5. NEVER LEAVE THE HEATER UNATTENDED FOR LONG PERIODS OF TIME AFTER ADDING FRESH WOOD. Before the heater is left unattended, the fire should be well established and the inlet air control set so the opening is open only half or less.
6. LEAVE THE HEATER'S INLET AIR CONTROL FULLY OPEN FOR 15 MINUTES AFTER ADDING FRESH WOOD TO AN EXISTING FIRE. This allows the gases to be driven off and shortens the length of time the dense smoke is likely to deposit creosote in the chimney connector and chimney.

CATALYTIC COMBUSTOR OPERATING TEMPERATURES:

Achieving Catalytic Light-Off. At least once during each burning cycle, the temperature within the heater should be raised high enough to cause the catalyst to become active. The most convenient time to do this is during fuel loading. With a new combustor, gas inlet temperatures between 500° to 600°F (260° to 320°C) will initiate catalytic burning. But as a combustor ages, its catalytic activity decreases, so an older combustor needs more heat during start-up to sustain catalytic action. During the combustor's normal range of life, temperatures between 600° and 700°F (320° to 370°C) will be sufficient for light-off.

Maintaining Catalytic Burning Conditions. During the start-up of a cold heater, a medium to high firing rate must be maintained for about 20 minutes. This ensures that the heater, catalyst and fuel are all stabilized at proper operating temperatures.

HEATER MAINTENANCE

The painted surfaces of the heater may be wiped free of dust with a soft cloth. The use of any other cleaning method may damage or remove the paint.

The brass finished trim components on the heater are coated with a clear baked-on enamel to prevent tarnishing. DO NOT polish the brass finished trim components. When cleaning is necessary, use mild soap suds and a soft cloth. After washing, dry the trim surfaces with a clean, dry, soft cloth.

This heater is equipped with a high temperature resistant glass panel. The glass may be cleaned when it is cool with a household glass cleaner. Take care to avoid chipping or scratching the glass. Chipped or scratched glass can break suddenly when heated. Do not use the heater with a broken glass panel.

The electrical power to the blower should be disconnected and the blower vacuumed or blown free of all lint, dust and ashes frequently. The motor is permanently lubricated and does not require oiling. The electrical cord should be inspected frequently and replaced if evidence of wear or damage is observed. Replace the cord only with the cord specified in the repair parts section of this manual.

Because continuous thermal self-cleaning action takes place within a catalytic combustor, it requires very little maintenance. Cleaning the catalyst with plain water can reduce buildup of the catalyst-retarding chemicals. Nothing but a soft fiber brush, low pressured air or plain water should be used to clean a catalyst. For information on how to remove the catalyst refer to the following section of this manual. The ceramic unit is fragile and it should be handled with care. A soak in warm or hot (not boiling) water for 20 minutes is ideal. Then allow the catalyst to cool at room temperature and rinse at medium pressure under a faucet. Allow the catalyst to dry before reinstalling in the heater. A cleaning once every year is sufficient for most. Clean it when you have your flue system cleaned or whenever and if ever it becomes plugged up.

Check the following items regularly during the heating season to ensure proper heater operation:

1. Condition of fuel feed door and ash removal door gaskets - replace gaskets if excessive wear is observed.
2. Condition of fuel feed door, ash removal door and cabinet door latching pawls and handles - ensure that operation of the latching pawls and handles will securely close the doors. Adjust as necessary.

At the end of each heating season, the heater should be thoroughly cleaned of all ashes. Ashes remaining in the heater in combination with moisture in the air can cause severe corrosion of the heater. All rust spots on the heater should be wire brushed and covered with a coat of high temperature paint. If the heater is to be stored until the next heating season, be sure the storage area is dry. The heater should never be used with damaged or missing parts.

Have a qualified heater installer inspect the complete system before cold weather each year. Make sure soot is removed. Replace all damaged or worn parts before using the heater.

WHEN AND HOW TO REPLACE THE CATALYTIC COMBUSTOR(S)

Tests conducted on actual wood heater installations indicate that the average expected operational life of a quality catalytic combustor is about 6000 operating hours. Remember, these are average test figures; actual combustor life of your heater's catalyst may be more or less, depending on operation procedures and normal care.

Whenever a catalytic combustor stops functioning, it should be replaced as soon as possible, or at least removed from the heater.

This heater employs two catalytic combustors. Indications that a combustor has stopped functioning and needs replacing are:

1. Sluggish heater operation.
2. Increased wood usage.
3. Increased build-up of creosote in the flue liner.

A simple test will determine if the catalytic combustor is functioning. To perform this test you should take note of the smoke exiting the chimney with a well established fire burning in the heater and the by-pass damper open. Then close the by-pass damper and observe the smoke exiting the chimney. If the catalytic combustor is functioning there should be a noticeable decrease in the amount of smoke exiting the chimney ten minutes after the by-pass damper is closed.

If you suspect that your heater needs new combustors, discuss the problem with your catalytic heater dealer, you may only need to clean the old combustors and change some operating habits.

When you do have to replace the combustors or just remove them for cleaning, here's how it's done:

1. Allow any fire in the heater to burn out and the heater to cool.
2. The combustors in this heater are both located inside the heater's firebox and can only be removed or replaced through the large round hole located in the top of the firebox. To remove or replace one or both of the combustors requires that the large round hole be uncovered. The hole is covered by the firebox cover plate (Key no. 8 on Figure 6). However, the same hole will be covered by the flue collar if you have converted the heater into a top vented model as described in the "REAR VENTED HEATER OR TOP VENTED HEATER?" section of this manual. Remove the hole's cover and gasket by removing the eight screws securing them to the firebox top. Care should be taken not to damage the gasket.
3. Reach into the hole and remove the combustor(s). The combustor(s) are encased by insulating material, but should come out without leaving any residue.
4. Inspect for residue where the combustors were sitting (commonly referred to as the combustor seat) inside the firebox. Wipe clean with a dry cloth. DO NOT USE DETERGENTS, STEEL OR METALLIC BRUSHES OR SOLVENTS.
5. Wrap the combustors with new insulating materials. Do not handle the new combustors any more than necessary for installation. Catalytic combustors are fragile.
6. Install the newly wrapped combustors. The new insulating material which encase the new combustors will form a tight seal between the combustors and the combustor seat when heated.

to control the burning rate of the wood, a certain amount of air must enter the heater at all times to assure the fire does not go out and the wood burns as cleanly as possible. Thus you should adjust the amount of wood you put in the heater to the outdoor temperature. Placing excessive wood in the firebox will cause excessive creosote formation in the chimney, waste wood, can plug up the catalytic combustion causing the heater to smoke or back puff into the room, as well as make the room uncomfortably warm.

If your heater burns too rapidly or overheats even on cold days, it may be because air is leaking around a loose ash door or feed door gasket. Check thoroughly for leaks where air may enter the heater at any location other than the normal air passages of the heater.

DO NOT USE A MANUAL STOVE PIPE DAMPER IN THE CHIMNEY CONNECTOR PIPES. USE OF THIS TYPE DAMPER CAN CAUSE DANGEROUS GASES TO COLLECT IN THE HEATER OR SPILL OUT INTO THE ROOM.

FINAL CHECKLIST OF DO'S AND DONT'S

DO'S:

1. Do read and follow the installation, operation and maintenance manual carefully.
2. Do install a smoke detector in an area that will give warning in the unlikely event that a fire develops in the area of the heater or the heater malfunctions.
3. Do be sure that there is a fire extinguisher of the proper type and good working order accessible in the unlikely event that a fire develops near the heater or the heater malfunctions.
4. Do check with local building officials to be sure the installation of the heater complies with all building codes and requirements and obtain required building permits.
5. Do plan your installation with safety as your primary consideration.
6. Do keep all flammable liquids, gases and pressurized containers away from the heater.
7. Do complete the installation before attempting to use the heater.
8. Do use only the prescribed materials and parts for the installation of the heater.
9. Do install the heater in an area that will minimize the hazards of persons coming in contact with the hot surfaces of the heater.
10. Do instruct all responsible persons in the proper and safe operation of the heater.
11. Do instruct all persons, especially children and elderly persons, of the hazards involved with the heater and improper and unauthorized tampering with the heater.
12. Do check the heater for proper adjustment and operation before leaving it unattended for long periods of time.
13. Do start a fire only with paper and kindling. The use of liquid fire starters can cause an explosion within the heater.
14. Do use only a Listed Factory-Built Residential Type and Building Heating appliance chimney or a properly constructed and maintained masonry chimney to vent this heater.
15. Do use 6-inch diameter chimney connector pipes made from a minimum of 24 gauge cold rolled steel.
16. Do place all ashes in a metal container with a tight fitting lid and place them on a noncombustible surface well away from other combustible materials until they have completely cooled.
17. Do check the door latching mechanisms and gaskets regularly and replace parts or make adjustments as needed to maintain the intended tightness of the fire chamber.
18. Do use a noncombustible floor covering beneath the heater as required.
19. Do observe all instructions regarding clearance between the appliance, chimney connector and combustibles.
20. Do store your fuel supply at least 36 inches from the heater.
21. Do burn only seasoned wood in this heater.
22. Do be sure the heater is located in an area where combustible vapors are not present.
23. Do use a chimney for this heater that is not used by another appliance.
24. Do assemble the chimney connector so that moisture that accumulates within the chimney will flow back toward the heater.
25. Do remove the ashes from the heater regularly.
26. Do store wood in such a manner as to keep it dry.
27. Do protect your hands with noncombustible gloves when loading the heater, removing ashes, etc.
28. Do keep the heater doors closed except when refueling the heater or removing ashes.
29. Do build fires of moderate intensity in the heater for the first three fires to allow the materials to adjust and cure before being subjected to the intense heat of a large fire.
30. Do leave the heater's primary and secondary inlet air controls fully open for 15 minutes after adding fresh fuel to an existing fire.
31. Do keep the catalytic combustors clean.

ORDER ALL REPAIR PARTS FROM YOUR ASHLEY DEALER
 BY SUPPLYING THE FOLLOWING INFORMATION:

1. PART NAME
2. PART NUMBER (Not Key No.)
3. MODEL NUMBER

FIGURE 21

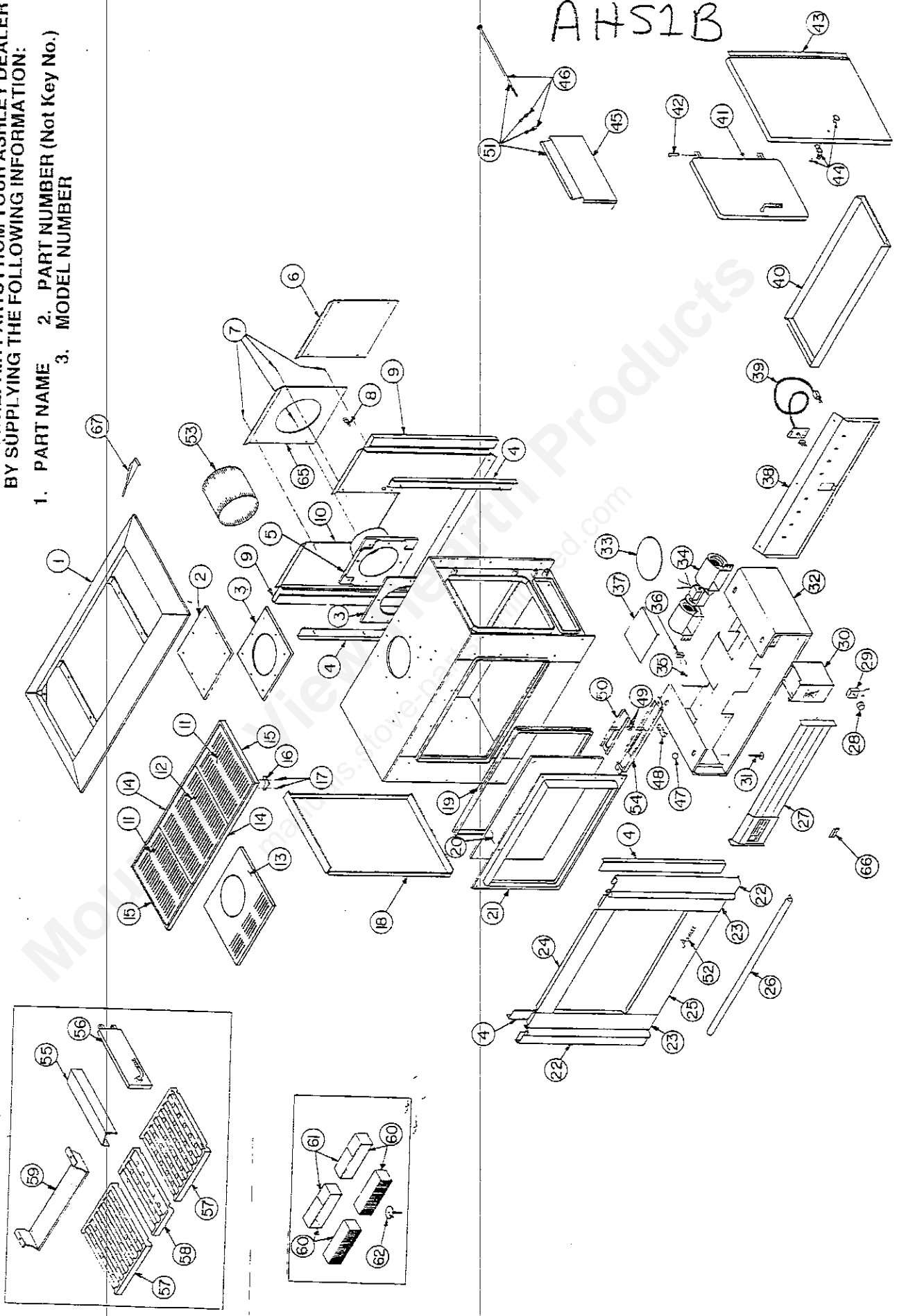

AHS1
 AHS1B

ORDER ALL REPAIR PARTS FROM YOUR ASHLEY DEALER BY SUPPLYING THE FOLLOWING INFORMATION:

1. PART NAME 2. PART NUMBER (Not Key No.) 3. MODEL NUMBER

FIGURE 22

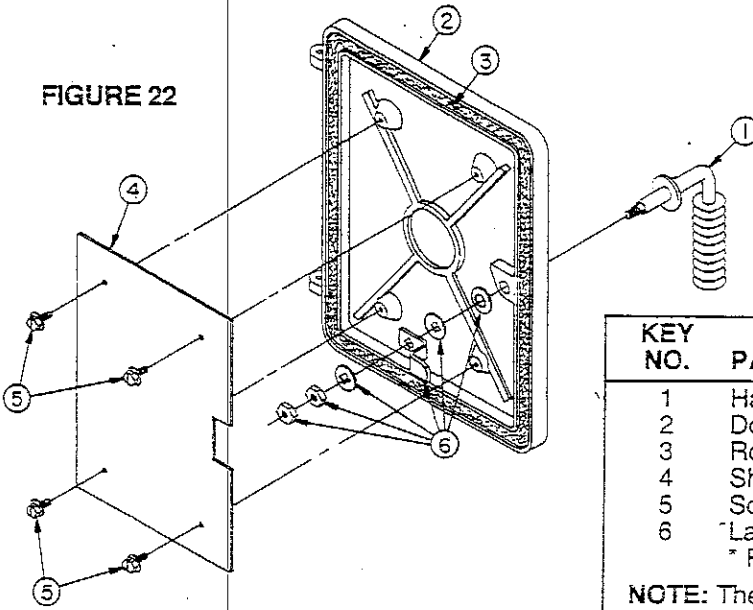

KEY NO.	PART NAME	QTY. Per Unit	PART. NUMBER
1	Handle Assy.	1	015905
2	Door Feed & Rope Assy.	1	035400
3	Rope Fiberglass	1	009535-03
4	Shield Door Radiation Ptd.	1	035402
5	Screw 1/4 x 1/2 Long Mach.	4	*
6	Latch & Latch Fasteners	1	035395
	* Purchase Locally		

NOTE: The complete feed door assembly may be ordered by using part number 035401 or individual components may be ordered as described above.

ORDER ALL REPAIR PARTS FROM YOUR ASHLEY DEALER BY SUPPLYING THE FOLLOWING INFORMATION:

1. PART NAME 2. PART NUMBER (Not Key No.) 3. MODEL NUMBER

FIGURE 23

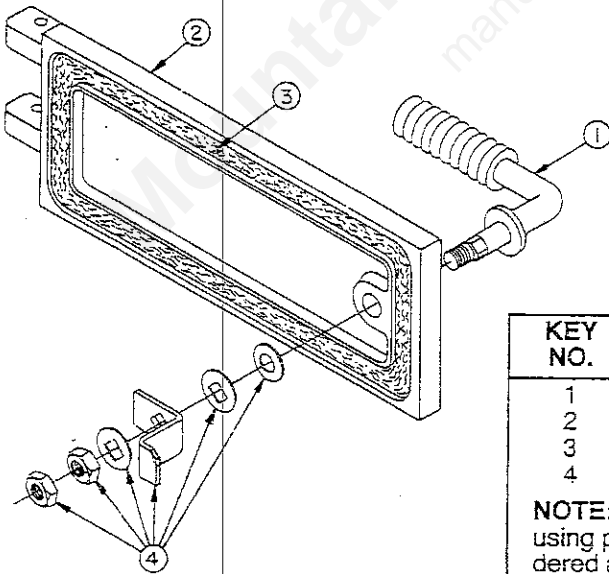

KEY NO.	PART NAME	QTY. Per Unit	PART. NUMBER
1	Handle Assy.	1	015905
2	Door Ash & Rope Assy.	1	035756
3	Rope Fiberglass	1	012053-01
4	Latch & Latch Fasteners	1	035395

NOTE: The complete ash door assembly may be ordered by using part number 035399 or individual components may be ordered as described above.

IF YOU HAVE A PROBLEM WITH YOUR HEATER

1. Contact or take it to the nearest Ashley dealer. If you cannot locate your Ashley dealer, call or write the Ashley Heater Company Customer Service Department as indicated below.
2. If you do not receive satisfactory service from the dealer within a reasonable time, write the Ashley Heater Company Customer Service Department and include the date you purchased your heater, its serial number, and details of the problem you are having.

Customer Service Department, Ashley Heater Company, Post Office Box 128, Florence, Alabama 35631, Telephone: 205-767-0330.

This warranty gives you specific legal rights, and you may also have other rights which vary from state to state.