



# CATALYTIC WOODBURNING FIREPLACE INSERT MODELS CAHF2 & CAHF2B

Installation, Operation and Maintenance Instructions

**SAFETY TESTED TO UL1482 AND LISTED BY WARNOCK HERSEY INTERNATIONAL, INC.**

## TABLE OF CONTENTS

IMPORTANT GENERAL INFORMATION	1
FIREPLACE AND CHIMNEY REQUIREMENTS	1
BUILDING CODES AND SAFETY STANDARDS	3
HOW THIS FIREPLACE INSERT OPERATES	3
UNPACKING AND INSPECTION	5
TOOLS AND SUPPLIES NEEDED FOR INSTALLATION	5
INSTALLATION PROCEDURES	5
SAFE USE	7
WOOD FACTS	7
OPERATION OF THE FIREPLACE INSERT	8
TO BUILD A FIRE	8
FIRE TENDING	9
CATALYTIC COMBUSTOR OPERATING TEMPERATURES	10
CATALYTIC COMBUSTORS EXPLAINED	10
INSERT AND CHIMNEY MAINTENANCE	11
ASHES-REMOVAL AND DISPOSAL	11
CREOSOTE-FORMATION AND NEED FOR REMOVAL	11
ICE-FORMATION AND PREVENTION	11
INSERT MAINTENANCE	11
WHEN AND HOW TO REPLACE CATALYTIC COMBUSTOR(S)	12
TROUBLESHOOTING	13
POSSIBLE CATALYTIC COMBUSTOR - RELATED PROBLEMS	14
CHECKLIST OF DO'S AND DON'TS	15
WARRANTY CLAIM INFORMATION	16
REPAIR PARTS	16
OPTIONAL ACCESSORIES	20
A FINAL WORD	20

## IMPORTANT GENERAL INFORMATION

This woodburning insert contains catalytic combustors which need periodic inspection and replacement for proper operation. It is against the law to operate this insert in a manner inconsistent with operating instructions in this manual, or if the catalytic element is deactivated or removed.

This insert is designed to burn only natural wood. This insert is not designed to burn artificial logs, processed fuels, coal, charcoal, plywood, trash, garbage, wrapping paper, preformed wood, or treated wood. These prohibited fuels may cause the insert and chimney to dangerously overheat or release poisonous gases into the dwelling. These prohibited fuels also contain elements such as lead, zinc and sulfur that will "poison" or deactivate the catalytic combustor. A poisoned catalytic combustor will not operate effectively and must be replaced. Any attempt to burn these prohibited fuels or to attach the insert to any other heating device can be very hazardous. This insert is not designed to be used in a mobile home.

Never use gasoline, gasoline type lantern fuels, kerosene, charcoal lighter fluid, or any similar liquids to start or freshen up a fire in this insert. The use or presence of these type fuels in or around the insert can cause an explosion and house fire resulting in personal injuries and property damage.

To assure that satisfactory and safe service is received from this fireplace insert:

1. Read these instructions before installing and using the fireplace insert.
2. Use these instructions as a guide during the installation of the fireplace insert.
3. Be sure these instructions become the property of and are reviewed by all future users of this insert to encourage proper operation and maintenance of this unit.

## FIREPLACE AND CHIMNEY REQUIREMENTS

This insert has been designed, tested for, and should only be installed in, a masonry fireplace and chimney built to the National Fire Protection Association (NFPA) standards. A copy of the NFPA standard Chimneys, Fireplaces, Vents, and Solid Fuel Burning Appliances may be purchased from the National Fire Protection Association, Inc., Batterymarch Park, Quincy, MA

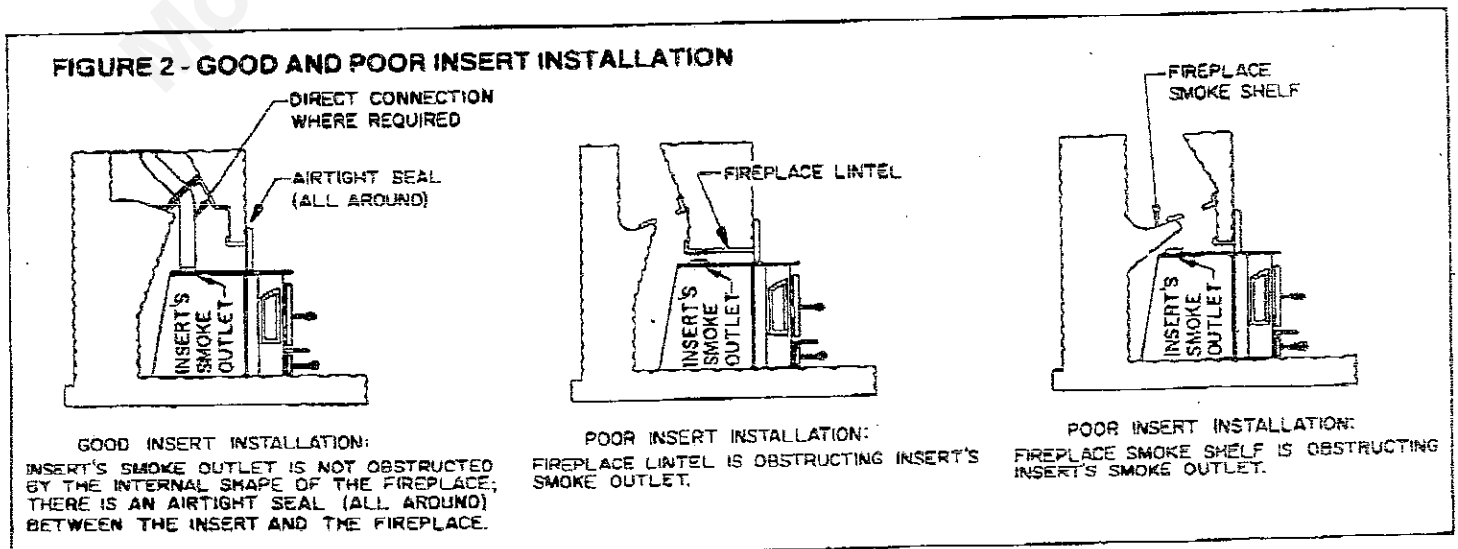
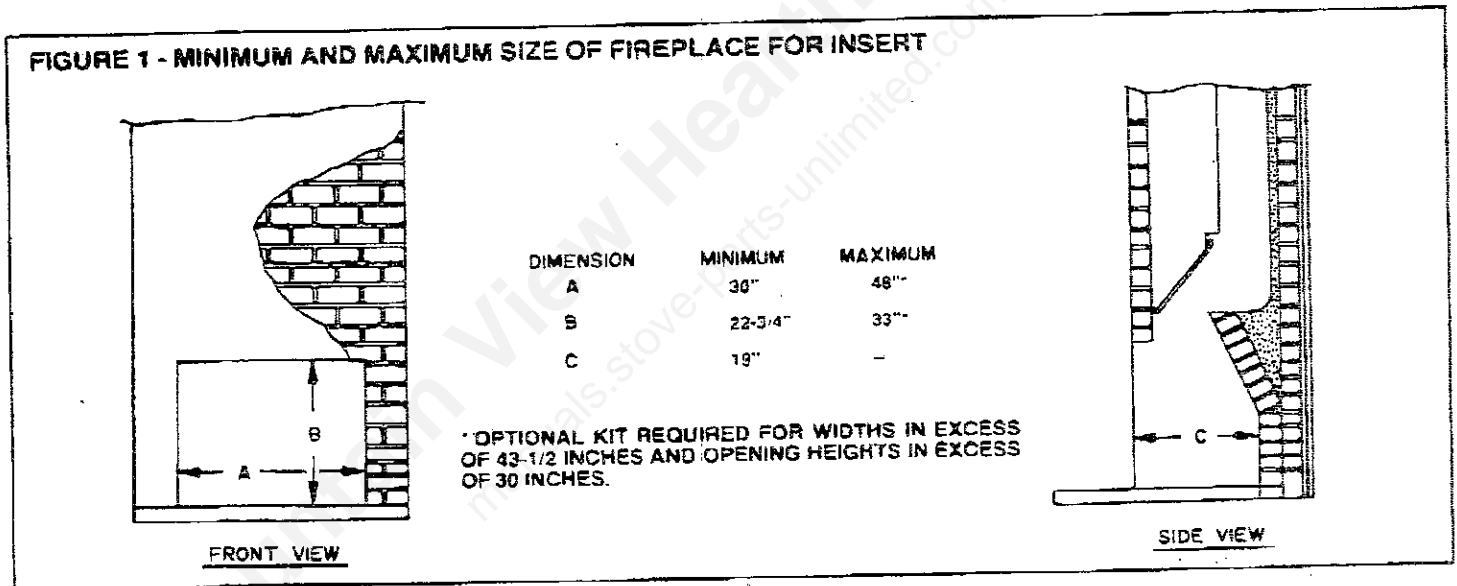
02258

To be sure the fireplace and chimney system meet the NFPA standards and is in good repair, it should be cleaned and inspected by someone familiar with the NFPA standards, knowledgeable about problems that may develop in fireplaces and chimneys and how these problems may be repaired.

This insert requires a good fireplace and chimney system to develop the vacuum usually referred to as "draft" necessary to pull combustion air into the firebox and the air to wash over the door glass. If this fireplace insert is installed in a sub-standard fireplace, a fireplace that is in poor repair, or the installation does not provide a reasonably air tight seal between the insert and fireplace, an unsafe condition may exist, the "draft" may be adversely affected, and unsatisfactory performance of the fireplace insert may occur. Air leaks of any volume into the fireplace or chimney will affect its performance but excessive air leaks will cause the fire in the insert to burn sluggishly and may cause smoke to spill out of the fireplace insert during fire tending and excessive creosote or soot collection in the chimney.

Proper installation of the surround top is required to prevent leakage of air or smoke between the insert and the face of the fireplace. The surround top included with the insert will adapt the insert to fireplaces with an opening height up to 30 inches and an opening width up to 43-1/2 inches. If the opening width exceeds 43-1/2 inches or if the opening height exceeds 30 inches, an optional surround kit described in the optional accessories section of this manual will be required. See Figure 1 for minimum and maximum dimensions of the fireplace this insert can be installed in. Do not attempt to install this insert in a fireplace that does not comply with these dimensions.

The internal shape of the fireplace must not cause the lintel area or the smoke shelf area to extend over the smoke outlet of the insert. Excessive obstruction of the smoke outlet by portions of the fireplace will cause restrictions of the smoke and gases flowing from the insert which can have detrimental effects on the insert performance similar to air leaks or insufficient chimney draft. Figure 2 shows good and poor insert installations. If a fireplace has dimensional or shape characteristics that are likely to cause poor performance of the insert, a skilled mason may be able to remodel the fireplace to provide a more suitable shape and size. If the fireplace cannot be modified by the skilled mason, your fireplace is probably unsuitable for the insert.



## BUILDING CODES AND SAFETY STANDARDS

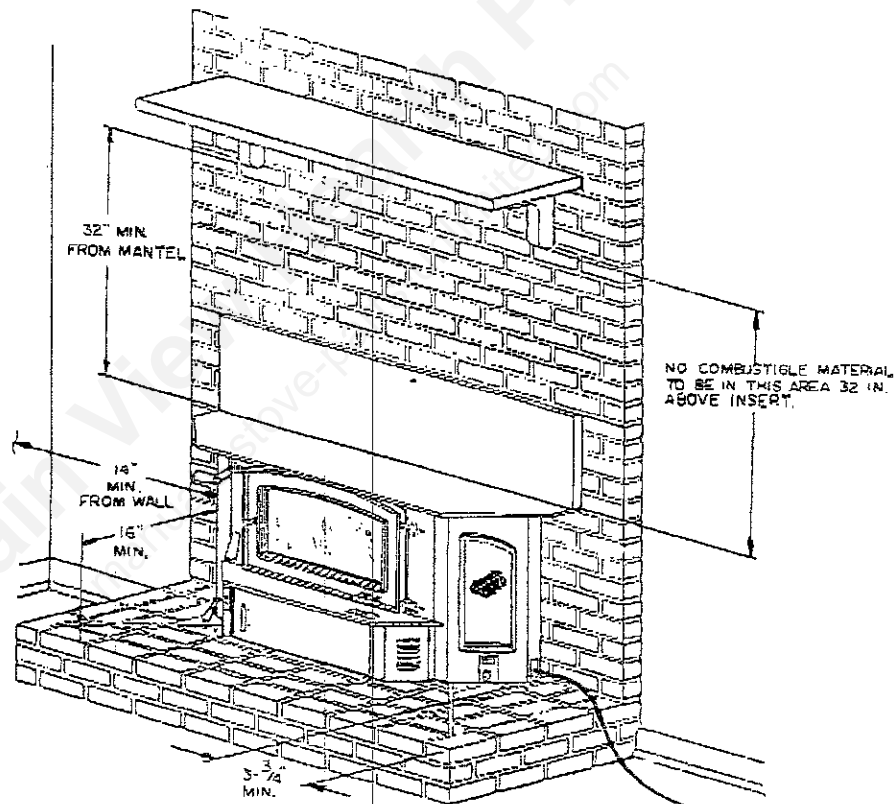
The Warnock Hersey listing mark on this fireplace insert indicates that the design and manufacturing of this insert and the contents of this manual comply with the Warnock Hersey International, Inc. standards for fireplace inserts. There may be additional requirements to be met in order to comply with local building codes or regulations. Be sure to check with your local building officials before beginning the installation.

The fireplace and chimney for this insert must comply with the standards of the National Fire Protection Association as indicated in the preceding section of this manual. Either obtain a copy of this standard and inspect your fireplace or have it inspected by a qualified person before installing the insert. **DO NOT** install the insert in a fireplace with an unlined chimney. The chimney must be lined and constructed of solid masonry not less than four inches thick or rubble stone masonry not less than twelve inches thick.

To comply with N.F.P.A. standards the floor must be protected by a noncombustible floor covering extending at least 16 inches in front of the face of the insert and 3-3/4 inches to each side of the insert's front panel ends. If the fireplace hearth does not provide this protection the floor must be protected by a 3/8 inch minimum thick non-combustible inorganic millboard having a thermal conductivity of  $k = 0.43 \text{ BTU/Ft.}^2/\text{in./Hr./}^\circ\text{F}$ . See Figure 3 for hearth requirements and clearances to combustibles.

NFPA STANDARD 211 requires fireplace inserts to be equipped with a connector to extend the insert's flue outlet to the first flue liner of the chimney. Where local codes require, or a connector is desired, the Model DC1A direct connect kit may be purchased from your insert dealer and used for this purpose. See the **INSTALLATION PROCEDURES** section and the **OPTIONAL ACCESSORIES** section of this manual for additional information about the DC1A kit.

**FIGURE 3 - HEARTH REQUIREMENTS AND MINIMUM CLEARANCES TO COMBUSTIBLES**



## HOW THIS FIREPLACE INSERT OPERATES

The chimney draft draws combustion air into the insert through adjustable openings located to the left and right of the insert's ash door. The amount of combustion air entering the insert is controlled by an inlet air damper control lever located at the lower left-hand front corner of the insert as shown by figure 4. Turning the lever counterclockwise increases the combustion air supply to the fire in the insert, and turning the lever clockwise lessens the combustion air supply to the fire in the insert. The gases driven out of the burning wood are either drawn through the insert's catalytic combustors or by-pass the combustors through a by-pass passageway that may be opened or closed by a by-pass damper control lever located at the upper left hand front corner of the insert as shown by figure 4. Pulling the by-pass damper control lever out opens the by-pass damper and pushing the lever in closes the by-pass damper. When the bypass damper is closed and the temperature and oxygen content of the gases is sufficient, the gases driven out of the wood will be consumed as they pass through the combustors, which are housed in the top of the insert's firebox. The by-pass damper must be open during the initial startup of a fire. The by-pass damper must be opened prior to opening the insert's fuel feed door to tend a fire or add more wood to a fire. **FAILURE TO OPEN THE BY-PASS DAMPER PRIOR TO OPENING THE FUEL FEED DOOR WILL CAUSE SMOKE, OR POSSIBLY FIRE, TO SPILL FROM THE INSERT THROUGH THE FUEL FEED DOOR OPENING.**

Heat from the fire is transferred to the air chamber between the firebox top and the outer cabinet top. This heat is transferred to the room by air blown through the air chamber by two blowers--one blower is mounted behind the insert's left side panel and one is mounted behind the insert's right side panel. The heated air enters the room through an opening above the feed door. Additional heat is radiated from the front of the insert.

An Auto/Manual switch allows either manual or automatic operation of the blowers. With the switch in the auto position, the blowers run only when there is sufficient heat available to activate blower operation; with the switch in the manual position, the blowers run continuously. (See Figure 4). A variable speed control knob allows the speed of the blowers to be adjusted to provide the airflow desired, (See Figure 4)

NOTE: This insert is equipped with two blowers that are operated with a manual/automatic switch and speed control. The switch setting should be set on automatic and the speed control set on low for the low and medium-low burn rates. The speed control for the medium-high and high burn rates can be set to the full high position.

Refer to figure 5 for a wiring diagram of the blower control circuits.

The blower's power cord is equipped with a three prong grounding plug. DO NOT REMOVE THE GROUNDING PRONG FROM THE PLUG. The power cord should be plugged into a 120 volt, 60 Hz. 15 amp properly fused and grounded receptacle. ALWAYS ROUTE THE POWER CORD AWAY FROM THE FIREPLACE to avoid damage to the cord from heat or dropped objects. The cord may be disconnected from the right side of the insert and attached to the left side if this will allow better routing of the cord. The procedure for relocating the cord is described in the "Installation Procedures" section of this manual.

FIGURE 4 - CONTROLS

BYPASS DAMPER CONTROL LEVER. PULL LEVER OUT TO OPEN BYPASS DAMPER OR PUSH IN TO CLOSE BYPASS DAMPER.

INLET AIR DAMPER CONTROL LEVER. TURN COUNTERCLOCKWISE TO OPEN INLET AIR DAMPER AND TURN CLOCKWISE TO CLOSE INLET AIR DAMPER.

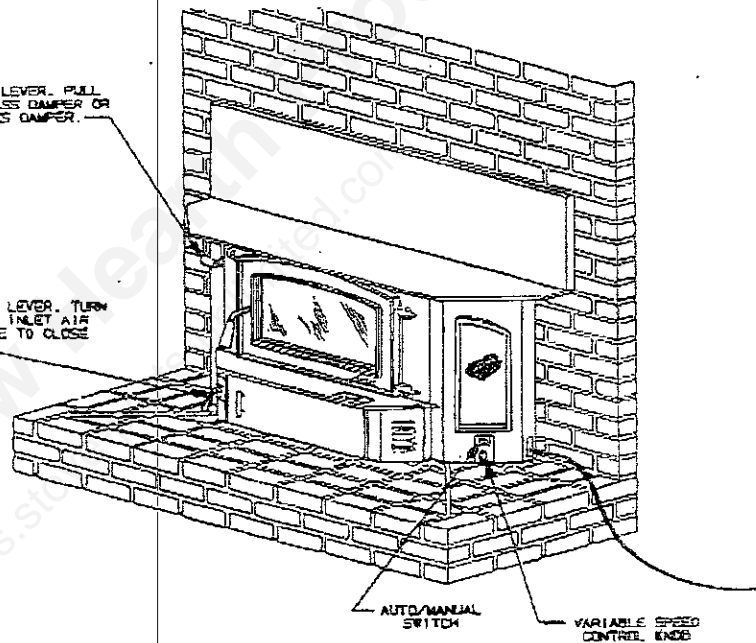
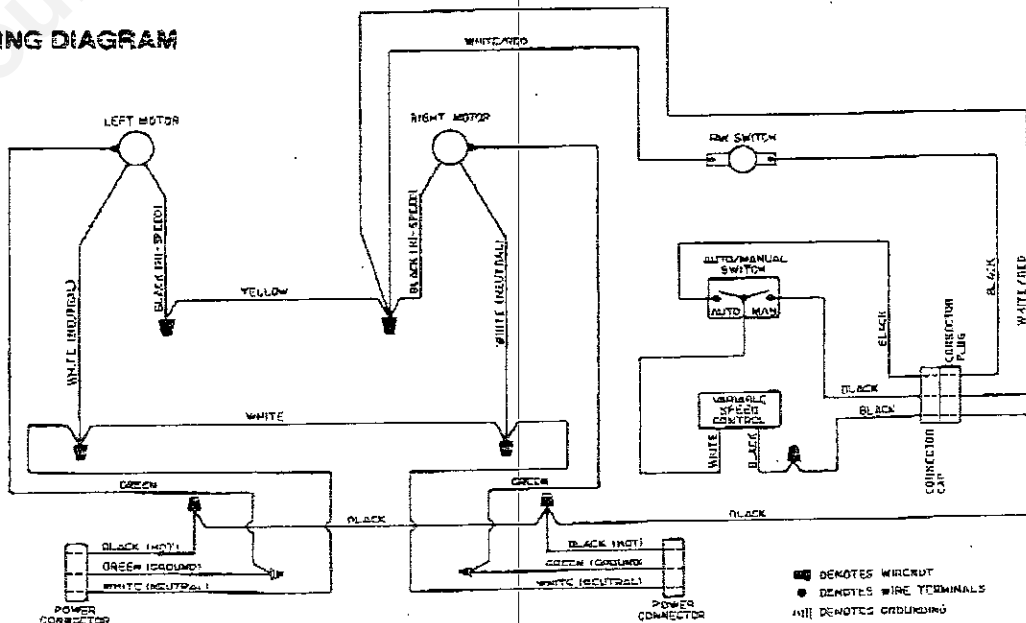


FIGURE 5 - WIRING DIAGRAM



■ DENOTES WIRING  
● DENOTES WIRE TERMINALS  
||| DENOTES GROUNDING

## UNPACKING AND INSPECTION

Remove all insert components from the shipping carton and inspect for damage or missing parts; use figure 14 to locate and identify the major components.

Locate the bag containing the shroud door handle and the inlet air damper control lever handle (key numbers 68 and 30 of figure 14). Use the fasteners provided to install the shroud door handle as shown by figure 14. Install the inlet air damper control lever handle by threading it onto the inlet air damper control lever (key number 29 of figure 14). Open and close the shroud door a few times to check its operation. Operate the inlet air damper control lever and the bypass damper control lever a few times as shown by figure 4 to check their operation.

Install the fuel feed door on the insert as shown by figure 14. Check the gaskets of the fuel feed door and ash removal door to assure they are securely in place, then check the sealing of the fuel feed door and ash removal door by opening and closing each door a few times. When closed, each door should create a tight seal to prevent leakage of air into the insert during operation.

Place the blower switch in the manual position, set the speed control to its high setting, plug the power cord into a properly fused and grounded receptacle and check the operation of the blowers.

If any parts are missing, if the levers, doors, or blowers fail to operate properly, or if any damage is found, report the problem to your insert dealer to get the problem corrected before proceeding with the insert installation.

Use only parts specified in these instructions for replacement or repair.

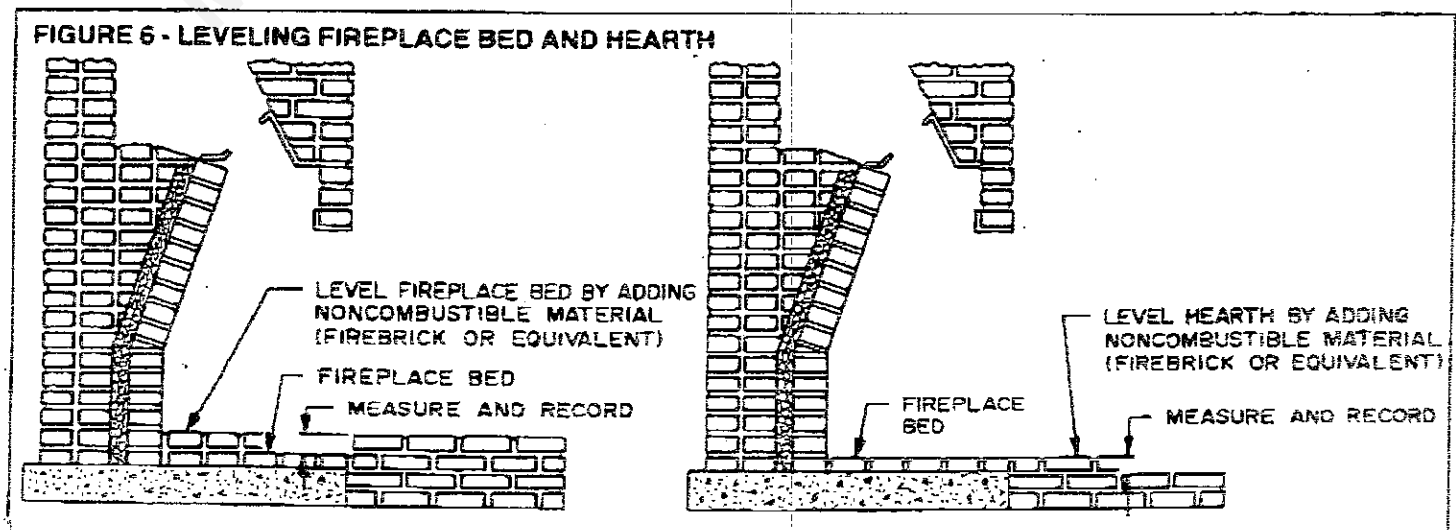
## TOOLS AND SUPPLIES NEEDED FOR INSTALLATION

Screw driver (straight blade medium size)  
Pliers  
Rule or measuring tape (24 inch minimum)

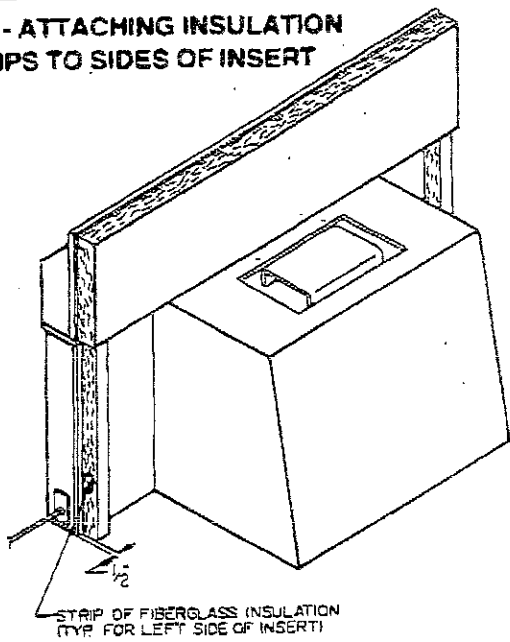
Pencil or chalk  
Rag or paper towels  
Scissors or shears (to cut fiberglass insulation)

## INSTALLATION PROCEDURES

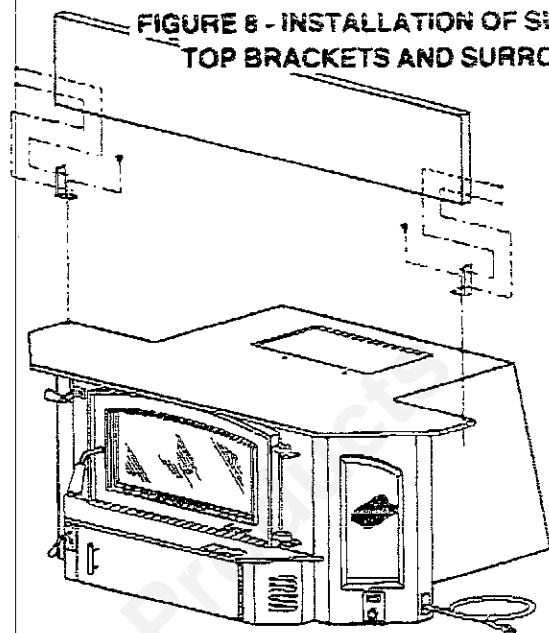
1. Clean the fireplace and chimney of all soot or creosote accumulations.
2. Inspect the fireplace and chimney for proper construction and to be sure they are in good condition.
3. Remove the fireplace damper plate and its closing mechanism or lock the damper plate in the open position to prevent it from being accidentally closed.
4. If the fireplace is equipped with an ash dump, seal it closed with furnace cement or mortar.
5. Check the height of the fireplace bed and hearth. If the bed and hearth are not level, build the lower surface up as shown by figure 6.
6. If local codes require, or if a direct flue connection is desired, purchase a DC1A Direct Connect Kit from your insert dealer and install it in the fireplace by following the instructions provided with the DC1A kit. If a DC1A kit is not to be installed, proceed to Step 7 of these instructions.
7. If the fireplace opening width is in excess of 43-1/2 inches or if its opening height is in excess of 30 inches, an optional surround kit described in the optional accessories section of this manual will be required; purchase the optional surround kit from your insert dealer and install ONLY its two surround sides at this time by following the instructions furnished with the optional surround kit. Do not install the optional surround kit's surround top at this time. NOW SKIP TO INSTALLATION STEP 11 ONLY IF THE SIZE OF THE FIREPLACE OPENING REQUIRES THE OPTIONAL SURROUND KIT.
8. If your fireplace opening width is 43-1/2 inches or less AND its opening height is 30 inches or less, the optional surround kit is not necessary; the surround top included with the insert will suffice—but DO NOT install the surround top at this time—proceed to installation step 9.



**FIGURE 7 - ATTACHING INSULATION STRIPS TO SIDES OF INSERT**

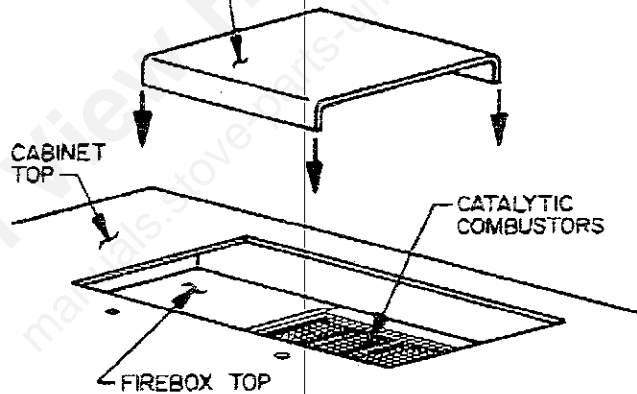


**FIGURE 8 - INSTALLATION OF SURROUND TOP BRACKETS AND SURROUND TOP**



**FIGURE 9 - INSTALLATION OF CATALYST COVER PLATE**

CATALYST COVER (PASS CATALYST COVER THROUGH HOLE IN CABINET TOP OF INSERT AS SHOWN AND SET ON FIREBOX TOP SO THAT CATALYTIC COMBUSTORS ARE COVERED.)



**FIGURE 10 - INSTALLATION OF THERMOMETER**

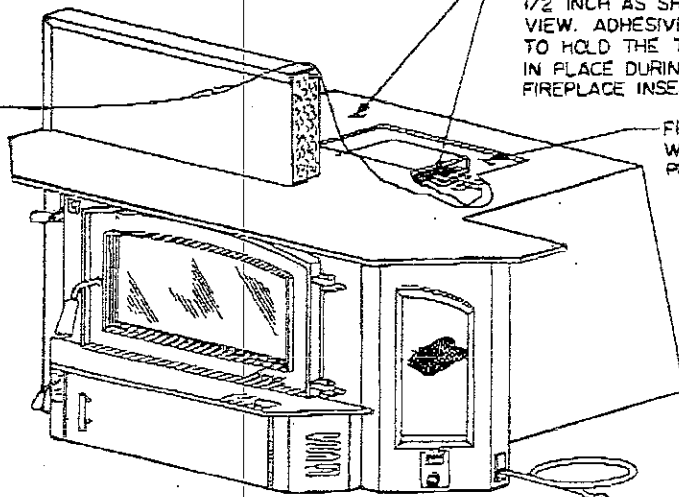
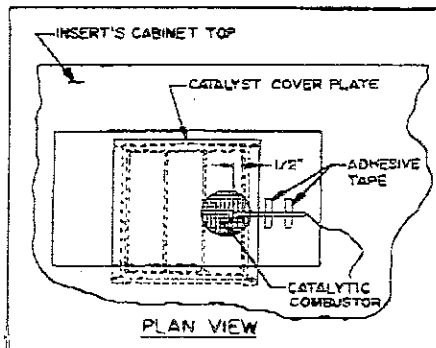
MOUNT PER INSTRUCTIONS SUPPLIED WITH THERMOMETER.

THERMOMETER PROBE INSTALLED. THE THERMOMETER PROBE SHOULD BE INSERTED UNDER THE CATALYST COVER PLATE AND SHOULD OVERLAP THE COMBUSTORS AT LEAST 1/2 INCH AS SHOWN BY THE PLAN VIEW. ADHESIVE TAPE MAY BE USED TO HOLD THE THERMOMETER PROBE IN PLACE DURING INSTALLATION OF FIREPLACE INSERT.

TEMPERATURE IS READ HERE.

INSERT'S CABINET TOP

FIREBOX TOP ON WHICH THERMOMETER PROBE RESTS.



9. Cut two 22 inch lengths of the roll insulation packaged with the insert; carefully remove the paper backing to expose the adhesive on one side of each strip and attach one strip to each side of the insert as shown by figure 7. Each strip of insulation should extend completely from the lower edge of the insert to its upper edge.
10. Remove the two factory-installed screws located toward the front top of the insert. Use these two screws to attach the two surround top brackets to the top of the insert as shown by Figure 8. **DO NOT INSTALL THE SURROUND TOP AT THIS TIME. IT WILL BE INSTALLED LATER.**
11. Locate the catalyst cover plate and set it over the catalytic combustors as shown by figure 9.
12. Take precautions to avoid scratching the fireplace hearth and push the insert into place in the fireplace so that the insert sides (or the optional surround sides described by step 7 above) fit firmly against the face of the fireplace and the insert is centered left to right in the fireplace opening.  
NOTE: The ash and feed doors, the ash retainer, the ash pan and the grate may be removed to reduce the weight of the insert during installation, but each part must be back in place before the insert is used.
13. If a DC1A kit was installed in the fireplace per installation Step 6 above, now is the time to connect the DC1A kit to the insert by following the instructions provided with the DC1A kit.
14. Install the surround top at this time:
  - a. Use the four screws provided in the hardware bag to attach the surround top included with the insert to the two surround top brackets installed by step 10. (See figure 8). -OR-
  - b. Use the four screws provided with the optional surround kit to install its top surround per the installation instructions provided with the optional surround kit.  
NOTE: If the face of the fireplace is made from rough masonry material with deep mortar joints, or the fireplace hearth is unlevel, additional insulation may be required to effectively seal the insert into the fireplace. If needed, unbacked fiberglass insulation of the type normally used in house construction may be used around and under the perimeter of the insert.
15. Reinstall the feed door and any other part removed by step 12.
16. Check to be sure the clearances between the insert and combustible materials are not less than specified by figure 3.
17. Route the blower cord away from the insert and plug it into a properly grounded and fused receptacle. If a more appropriate location of the cord can be achieved by attaching the cord to the left side of the insert, relocate the cord as follows:
  - a. Be sure the cord is unplugged.
  - b. Remove the two screws and the cover plate (key 38, figure 14) from the left side panel (key 39, figure 14) of the insert.
  - c. Remove the two screws and the cover plate from the insert's right side panel and disconnect the special connector plug that joins the power cord to the internal blower wiring by pressing on the catch releases on the top and bottom of the connector and pulling on the connector.
  - d. Attach the cord connector to the mating connector in the insert's left side panel and reattach the cover plates to each side panel.
18. Build a fire in the insert and after the fire is burning well and the chimney draft is well established, pass a lighted match or candle along the joint between the insert and the face of the fireplace and between the hearth and the insert. If the flame is drawn into these joints, room air is being drawn in. If a significant amount of room air is being drawn in, scraps of regular fiberglass insulation can be pushed into the leaking spaces with a screwdriver or similar tool to further reduce the air leaking into the fireplace. A roll of fiberglass insulation has been furnished with this insert expressly for the purpose of cutting pieces of insulation from it to push into the leaking spaces. Proper installation of the insert is complete when an air tight seal between the entire insert perimeter (including its surround top) and fireplace face is achieved.  
This air tight seal is very important because it ensures that the draft developed by the chimney is drawn only through the insert. This solitary draft route through the insert will in turn help ensure that any fire in the insert has access to all the oxygen created by the chimney draft. Oxygen is necessary for any fire to burn properly, so with an air tight seal the fire in the insert can more accurately be controlled by regulating the amount of oxygen (combustion air) entering the insert. So, as you can see, for sufficient draft through the insert and for improved insert heating capabilities, an air tight seal between the entire insert perimeter (including its surround top) and fireplace face is necessary for any insert installation.

#### SAFE USE

**Inspection After Installation:** Have the entire installation inspected by the local fire department, building code inspector or fire marshal to be sure your installation is safe. Have this manual on hand for a reference if needed. Keep the manual in a safe place where it can be found when needed.

**Operation & Maintenance:** Follow the instructions described by this manual.

**Hot Surfaces:** Keep children away from the insert. To avoid burns, do not touch the insert until it is cool.

**Smoke Detector:** Install a smoke detector on each floor of your home. In case of fire it can provide time to escape.

#### WOOD FACTS

As previously mentioned, only natural wood should be burned in this insert. Of course, enough newspaper to start the wood fire is acceptable.

The small amount of wood used in daily fire tending should be kept in a noncombustible container at least 36 inches away from the insert.

The amount of heat you receive from the insert, the degree of control you have over its heat output, how safely you operate your insert, and how often you have to clean its catalytic combustor system and its venting system (which consists of the direct connect system and the fireplace chimney) are all somewhat dependent on how much you know about wood and burning wood. The two factors that determine the amount of heat you get from a quantity of wood is its density and moisture content. All species of wood, when oven dried and burned, will produce approximately 8,600 BTU's per pound of wood; but because hardwoods are more dense than softwoods, a piece of hardwood will produce more heat than a piece of softwood of equal size and moisture content.

Before wood can burn, the water trapped in the wood must be boiled away. As anyone who has ever boiled water knows, it takes a considerable amount of heat to boil even a cup of water until it is all boiled away. Because freshly cut green wood or wet wood may be 50% water by weight, a considerable amount of the heat produced by burning green or wet wood is consumed by boiling the water out of the wood before it will burn. For this reason, green or wet wood is likely to produce a smoldering smokey fire and chimney temperatures that are cool enough to cause rapid accumulation of creosote. Burning green or wet wood can also waste up to 50% of the heat you should be getting in your home and maintaining catalytic combustion will be much more difficult due to the water vapor coming off the wood and cooling the combustor temperature too much.

To prepare wood for the most economical and trouble free burning, it should be cut, split, and stacked out of the rain with its ends exposed for at least 6 months before it is burned. Wood that has been "seasoned" in this fashion will normally dry naturally until it is approximately 20% water by weight.

Choosing the proper kind of firewood to burn in the insert depends on what is available to you.

Softwoods like pine, spruce, and fir are easy to ignite because they are resinous. They burn rapidly with a hot flame, but, since a fire built entirely of softwoods burn out quickly, it required frequent attention and replenishment. This characteristic of softwoods can be a boon, if you want a quick-warming or short burning fire that will burn out before you go to bed.

If you do have a choice, for a long-lasting fire, it is best to use the heavier, denser hardwoods such as ash, beech, birch, maple and oak; these hardwood species burn less vigorously than softwoods and with a shorter flame; oak gives the most uniform flame and produces steady, glowing coals.

By mixing softwoods with hardwoods, you can achieve an easily ignited and long-lasting fire.

To get an idea of how firewood is described and sold, you should first know that the most common measure is the cord. A cord is a tightly stacked pile of logs 8 feet long, 4 feet high, and 4 feet deep. The logs are usually cut 2 feet long, but you can have them cut into shorter lengths. A partial cord, called a face cord or a rick, is the same length and height as a cord, but its depth can be anywhere from 1 to 3 feet.

Wood is also sold by the ton. A ton of air-dry, dense hardwood (oak, hickory, maple, ect.) is equal to approximately one-half cord.

If you buy wood by weight, look for the driest wood. Don't pay for extra water!

Small twigs and branches found in your yard and wood wastes found around sawmills are also good.

When you buy wood, request a mixture of wood species and diameter sizes.

The wood should be generally sound, but don't worry about small pockets of rotten wood that you may find in logs.

For more specific information on how to select and obtain good firewood, write the Superintendent of Documents, U.S. Government Printing Office, Washington, D.C., 20402, and request a copy of Forest Service Leaflet No. 559.

#### THIS CHART SHOWS HEAT VALUE PER CORD OF AIR-DRIED WOOD ONLY!

Type	Average Weight Per Cord	BTU Heat Value in Air-Dried Cord	Order of Most Heat Per Cord
Ash	2,950 lbs.	22,600,000	11 th
Aspen	1,900 lbs.	17,700,000	15 th
Basswood	1,900 lbs.	17,001,000	16 th
Beech	3,240 lbs.	27,800,000	3 rd
Birch (Yellow)	3,000 lbs.	26,200,000	6 th
Cherry	2,550 lbs.	23,500,000	10 th
Elm	2,750 lbs.	24,500,000	7 th
Hemlock	2,100 lbs.	17,910,000	13 th
Hickory	3,595 lbs.	30,600,000	1 st
Maple (Hard)	3,075 lbs.	29,000,000	2 nd
Maple (Soft)	2,500 lbs.	24,000,000	9 th
Oak (Red)	3,240 lbs.	26,300,000	5 th
Oak (White)	3,750 lbs.	27,700,000	4 th
Pine (White)	1,800 lbs.	17,900,000	14 th
Spruce	2,100 lbs.	18,100,000	12 th
Tamarach	2,500 lbs.	24,010,000	8 th

### OPERATION OF THE FIREPLACE INSERT

THE PAINT ON THE EXTERIOR OF THE INSERT WILL GO THROUGH A CURING PROCESS DURING THE FIRST FIRING OF THE INSERT AND WILL EMIT SOME SMOKE AND ODOR. BE PREPARED FOR THIS BY RAISING A WINDOW OR OPENING A DOOR TO PROVIDE VENTILATION.

The first time the insert is fired, the fire should be one of moderate intensity to allow the paint to cure slowly and the other components to adjust to their expanded size before being subjected to the intense heat of a large fire.

#### TO BUILD A FIRE

1. Fully open the insert's inlet air damper by turning the insert's inlet air damper control lever to its farthest counter-clockwise position. (See figure 4).
2. Fully open the insert's bypass damper by pulling the insert's bypass damper control lever to its outermost position. (See figure 4).
3. Open the insert's fuel feed door and place several wadded grapefruit-size newspaper balls toward the back of the firebox beneath the by-pass damper. Be sure the insert's ash removal door is securely closed.
4. Cover the newspaper balls with dry kindling sticks. Place the kindling sticks close enough to one another so the flames can move easily from one stick to the other. If the kindling is packed too tightly, the fire will suffocate, smoke and then die out.

**NOTE:** Softwoods make better kindling than hardwoods because the softwoods burn faster than the hardwoods.)

5. Light the wadded balls of paper in the insert. Leave the fuel feed door slightly ajar (approximately 1 to 2 inches) to allow plenty of oxygen to reach the fire, but **DO NOT LEAVE THE INSERT UNATTENDED.**

**WARNING: NEVER LIGHT OR REKINDLE A FIRE WITH KEROSENE, GASOLINE, OR CHARCOAL LIGHTER FLUID: RESULTS CAN BE FATAL.**

6. Once the original kindling is well lit, add more kindling and 2 or 3 logs about three inches in diameter. Be careful not to smother the fire. Stack the new wood pieces carefully near enough to keep each other hot, but far enough away to allow adequate air flow between them. **NEVER LEAVE THE INSERT UNATTENDED WHILE ANY OF ITS DOORS ARE NOT SECURELY CLOSED.**

7. Once the logs begin to burn, securely close the insert's fuel feed door. (See the "CATALYTIC COMBUSTOR OPERATING TEMPERATURES" section of this manual for important catalytic information.)

**CAUTION: OPERATING THE INSERT WITH THE FUEL FEED DOOR OR THE ASH REMOVAL DOOR OPEN CREATES AN ABNORMAL FIRING CONDITION WHICH CAN OVERHEAT THE INSERT, CHIMNEY AND ADJACENT COMBUSTIBLE MATERIALS. THIS CAN DRASTICALLY SHORTEN THE INSERT'S LIFE, THE CATALYTIC COMBUSTOR'S LIFE, AND VOID THE FACTORY WARRANTIES OF THE INSERT AND ITS COMPONENTS.**

8. When all the wood in the firebox is burning well, finish loading the insert in the following sequence:

FIRST - Open the fuel feed door.

SECOND - Load the insert's firebox with the desired amount of wood.

NOTE: Probably the least understood requirement in maintaining a good fire is that of establishing a good base of coals. Many new insert users hesitate to load enough wood to sustain a fire. A good bed of hot coals will maintain a more even temperature as well as get a new load of wood started burning easily.

THIRD - Securely close the insert's fuel feed door.

9. During the start-up of a cold fireplace insert, a medium to high firing rate must be maintained with the bypass damper and the inlet air damper open for about 20 minutes to ensure the insert, catalyst, and wood are all stabilized at proper operating temperatures; therefore, wait about 20 minutes after loading the insert with wood before closing the bypass damper and adjusting the inlet air damper in the following sequence:

FIRST - Close the bypass damper. The bypass damper is closed by pushing the insert's bypass damper control lever to its innermost position. (See Figure 4).

SECOND - After closing the bypass damper, adjust the inlet air damper for the desired heat and burn rate. The inlet air damper is adjusted by turning the insert's inlet air damper control lever to the proper setting which will produce the desired heat and burn rate, (See figure 4). The proper inlet air damper setting can only be obtained by trial since conditions of fuel, space being heated, individual preference, etc., vary. For most conditions, good results can be obtained by setting the inlet air damper lever at its half-open position. After some experience with the insert, you will learn the best setting for your needs. The more you close the air damper, the lower and slower the fire will burn; the more open the air damper, the hotter and faster the fire will burn.

Let each load of wood burn down to a good coal bed. Frequent reloading will cause major fluctuations in temperature and wood/air mix, thereby reducing efficiency.

How long a load of wood burns will vary considerably with the variables such as type of wood, how well the wood is seasoned, the inlet air control setting, the position of the fireplace in the house, and how well the house is insulated.

Refer to the "HOW THIS FIREPLACE INSERT OPERATES" section of this manual for blower operation information.

#### FIRE TENDING:

Fire tending is the occasional re-positioning of the burning wood to ensure air flow through it and adding new wood as needed. With experience, you should determine how often fire tending is required to maintain the desired heat output of the insert. To ensure safe and satisfactory performance of the insert, the following rules should be observed:

1. **KEEP THE ASH AND FEED DOORS CLOSED EXCEPT WHEN TENDING THE FIRE OR REMOVING ASHES.** Operating the insert with the doors open can cause the insert to dangerously overheat and increase the possibility of smoke, fire, ash, or sparks escaping the insert and damaging the dwelling or its contents.
2. The following sequence should always be followed when opening the insert's fuel feed door to prevent smoke and possibly fire from spilling out of the heater:
  - a. Fully open the inlet air damper.
  - b. Fully open the bypass damper.
  - c. Wait about one minute, then open the fuel feed door.
3. Never overfill the insert to the point that the by-pass damper is blocked. Overfilling the insert can cause it to overheat, create a fire hazard, and damage the heater.
4. When refueling an insert or when operating it at a high firing rate, the bypass damper should be in the open position.
5. **DO NOT OVERFIRE THE INSERT.** If any part of the insert (other than its combustors) begins to glow, the insert is being overfired. Immediately turn the insert's inlet air damper control lever to its closed position as shown by figure 4 and keep the insert's door closed; these actions should decrease the fire intensity and allow the insert to cool down. Overfiring can cause a fire hazard and it can greatly shorten the life of the insert.
6. **NEVER LEAVE THE INSERT UNATTENDED FOR LONG PERIODS OF TIME AFTER ADDING FRESH WOOD.** Before the insert is left unattended, the fire should be well established and the inlet air damper control lever set to a setting which will not overfire the insert.
7. ~~Immediately~~ After refueling a hot insert that has a catalyst temperature below 500°F (260°), the insert should be operated at

a medium to high firing rate with the bypass damper open for about 10 minutes to ensure the insert's catalyst reaches the proper operating temperature, then close the bypass damper and set the insert's inlet air damper to the desired setting. (Also see the "CATALYTIC COMBUSTOR OPERATING TEMPERATURES" section of this manual for more catalyst information.)

8. Generally, immediately after refueling a hot insert that has a catalyst temperature above 500° (260°C), the insert's bypass damper may be closed and the inlet air control reset to the desired setting which will provide the desired heat output; however, sometimes (depending on chimney draft and condition of the wood being used) it is necessary to leave the bypass damper and inlet air damper fully open for a few minutes to help ensure that the new load of wood has enough oxygen to start burning properly.

### CATALYTIC COMBUSTOR OPERATING TEMPERATURES:

**Achieving Catalytic Light-Off.** At least once during each burning cycle, the temperature within the insert should be raised high enough to cause the catalyst to become active. The most convenient time to do this is during fuel loading. With a new combustor, gas inlet temperatures between 500° to 600°F (260° to 320°C) will initiate catalytic burning. But as a combustor ages, its catalytic activity decreases, so an older combustor needs more heat during start-up to sustain catalytic action. During the combustor's normal range of life, temperatures between 600° to 700°F (320° to 370°C) will be sufficient for light-off.

NOTE: A thermometer for monitoring the insert's internal temperatures may be purchased and installed on the insert as shown by figure 10. We recommend the Condor High-Temp Meter Model 9-86 thermometer.

**Maintaining Catalytic Burning Conditions:** During the start-up of a cold insert, a medium to high firing rate must be maintained for about 20 minutes. This ensures that the insert, catalyst and fuel are all stabilized at proper operating temperatures. Even though it's possible to have gas temperatures reach 600°F (320°C) within two to three minutes after a fire is started, if the fire is turned down immediately to low fire conditions it will result in either the fire or the combustor going out.

During the refueling of a hot insert that has an internal firebox temperature below 500°F (260°C), the insert should be operated at a medium to high firing rate with its bypass damper open for about 10 minutes to ensure that the catalyst reaches 600°F (320°C). At the end of a burn cycle, it's possible that the amount of burning charcoal might not provide sufficient temperatures or fuel for the catalyst. Therefore, firing a new load of wood with the insert's inlet air damper open to ensure a medium to high firing rate for 10 minutes ensures sufficient temperatures and proper amounts of volatiles for catalyst operation.

Generally, when refueling a hot insert that has an internal firebox temperature above 500°F (260°C), temperatures within the firebox will be hot enough to maintain catalytic burning and wood pyrolysis so that immediately after loading the wood, the bypass damper may be closed and the inlet air damper set to the desired setting which will provide the desired heat output; however, sometimes (depending on chimney draft and condition of the wood being used) it is necessary to leave the bypass damper and inlet air damper fully open for a few minutes to help ensure that the new load of wood has enough oxygen to start burning properly.

**The "Glow" Misconception:** A catalyst does glow during certain stages of combustion. However, the determination that a catalyst is not working simply because it doesn't "glow" is an inaccurate conclusion. During the low burn cycle, when the catalyst is doing the bulk of its work, it usually does not glow.

### CATALYTIC COMBUSTORS EXPLAINED

Under normal conditions, hydrocarbons and other potentially flammable products in wood smoke have a wide range of ignition temperatures. Many won't burn below about 1200°F or even higher. In most woodburning inserts, the average temperature in the firebox is only 700°F to 800°F during a burn cycle. Thus, much of the wood smoke passes through the insert unburned, wasting a good bit of the potential heat in the wood. Worst, some of the unburned smoke products condense and accumulate as dangerous creosote in the insert's venting system (which consists of the direct connect system and the fireplace chimney) while other smoke products are expelled out the chimney to pollute our environmental air. However, when wood is correctly burned in an insert properly equipped with a catalytic combustor system, the majority of the smoke generated by the burning wood is disposed of (burned) so well that the insert's combustion efficiency is improved, there is less dangerous creosote to accumulate in the insert's venting system, and there is less harmful air pollutants to pollute our environmental air.

A catalytic combustor is a ceramic honeycomb-type structure (the combustor) which is chemically coated with a compound known as noble metal (the catalyst). The catalyst, metals like platinum and palladium, have chemical properties that, when heated to as little as 500°F (260°C), enable the combustor to "light-off" (ignite) and burn (oxidize) the majority of the hydrocarbons and other flammable products present in the unburned smoke of a wood fire as the smoke passes through the combustor on its way to the insert's venting system. In other words, a catalyst is an element which will cause something to happen under conditions by which they would not normally happen, without being consumed or used up by that reaction. In an insert equipped with catalytic combustors, this simply means that the catalyst is allowing the hydrocarbons and other flammable products in wood smoke to be burned at temperatures as low as 500°F (260°C) rather than at the 1100°F to 1500°F temperatures normally required to burn the same smoke products.

Once the catalytic combustor begins burning the smoke entering the combustor, the temperature in the combustor will continue to rise as long as there is smoke and sufficient oxygen present, often to temperatures exceeding 1800°F, although the heater's firebox temperature will be much less. As the temperature in the combustor exceeds 1000°F, the combustor may glow cherry red - this will generally happen very soon after the combustor starts burning the smoke and will last approximately one hour, depending upon the amount and type of wood being burned in the insert.

The combustor will not - and should not - glow cherry red for the entire burning of the wood load because combustors will glow only when operating above 1000°F whereas most catalytic burning does and should occur below that temperature. Therefore, the catalytic combustor need not glow to be working. In some catalytic combustor equipped inserts the combustors cannot be seen during insert operation anyway, so glowing catalytic combustors are not very important; however, maintaining proper operating temperatures is important.

## INSERT AND CHIMNEY MAINTENANCE

### ASHES-REMOVAL AND DISPOSAL:

Ashes should not be allowed to accumulate until they obstruct the airflow through the burning wood. If ashes are allowed to accumulate to within two inches of the bottom of the grates, poor burning of the fuel is likely, and the grates will be damaged from overheating.

When removing the ash pan from the insert, wear gloves to protect your hands from glowing embers and hot surfaces. **ASHES SHOULD BE PLACED IN A METAL CONTAINER WITH A TIGHT FITTING LID. THE CLOSED CONTAINER OF ASHES SHOULD BE PLACED ON A NONCOMBUSTIBLE FLOOR OR ON THE GROUND, WELL AWAY FROM ALL COMBUSTIBLE MATERIALS, PENDING FINAL DISPOSAL. IF THE ASHES ARE DISPOSED OF BY BURIAL IN SOIL, OR OTHERWISE LOCALLY DISPERSED, THEY SHOULD BE RETAINED IN THE CLOSED CONTAINER UNTIL ALL CINDERS HAVE THOROUGHLY COOLED.**

### CREOSOTE - FORMATION AND NEED FOR REMOVAL

When wood is burned slowly, it produces tar and other organic vapors which combine with expelled moisture to form creosote. The creosote vapors condense in the relatively cool chimney flue of a slow burning fire. As a result, creosote residue accumulates on the flue lining. When ignited, this creosote makes an extremely hot fire. Use of a catalytic fireplace insert **DOES NOT** eliminate the need for periodic chimney inspections and cleaning to reduce creosote. Failure to remove creosote buildup can result in chimney fires.

The chimney and the direct connect system, where used, should be inspected at least once every two months during the heating season to determine if a creosote buildup has occurred. If creosote has accumulated, it should be removed to reduce the risk of a chimney fire. The inspection should also include a check for cracked chimney liners or any other sign of deterioration.

When performing periodic chimney maintenance and cleaning, it is best to always remove the insert from the fireplace so creosote that may have formed in the chimney and direct connect system does not fall back into the insert where it could clog the insert's catalyst and bypass system.

There are special brushes available for cleaning chimneys and direct connect system flue pipes. Many areas have professional chimney cleaning services. Most fire departments will make free chimney inspections and can provide help in locating chimney and direct connect system.

**YOU SHOULD ALWAYS CLEAN AND INSPECT YOUR CHIMNEY AND DIRECT CONNECT SYSTEM BEFORE EACH HEATING SEASON.**

The insert should be pulled forward from the fireplace sufficiently to allow thorough cleaning of the fireplace, direct connect system and the chimney. We recommend that the fireplace, direct connect system and the chimney be inspected and cleaned before each heating season by an experienced professional who works with chimneys and fireplace insert direct connect systems on a regular basis.

For further information pertaining to direct connect systems, see the installation and maintenance instructions which came with the direct connect kit when it was purchased.

If a chimney fire occurs, diminish the fire in the insert by closing the insert's inlet air control. Call the fire department and protect the roof by wetting it with a garden hose or buckets of water. After the chimney fire is over, thoroughly inspect all combustible materials around the chimney that might have been ignited by the intense heat. The chimney and the direct connect system should then be inspected for any damage and repairs made if necessary.

Although a properly constructed chimney should not be damaged by a chimney fire, these fires can be prevented by:

1. Burning well seasoned wood. Green or wet wood increases the chances of creosote forming.
2. Cleaning and inspecting the chimney and the direct connect system regularly.

### ICE-FORMATION AND PREVENTION

Most of what you see coming from the chimney of a properly operating catalytic insert is water vapor. In extremely cold weather, and with some exterior chimneys, this vapor may freeze in the chimney to the point of actually blocking the chimney and extinguishing the fire. In such weather, occasionally burn the insert with the by-pass open and the inlet air control set to its most open position to melt any possible ice buildup.

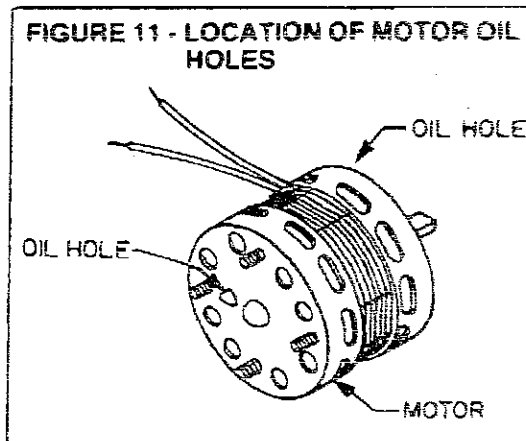
### INSERT MAINTENANCE

The painted surfaces of the insert may be wiped free of dust with a soft cloth. The use of any other cleaning method may damage or remove the paint. A high temperature paint available at most hardware stores can be used to touch up the insert.

Check the operation of the bypass damper control lever and the inlet air damper control lever regularly to ensure proper operation. Adjustments may be made if necessary.

The electrical power to the blowers should be disconnected and then the blowers and the grilles of the front panels vacuumed or blown free of all lint, dust and ashes frequently.

At least once a year unplug the power cord and place three drops of S.A.E. 20 oil in both the front and rear bearing oiler holes in the motor housing of each blower. (See figure 11 for oil hole locations in motors).



The power cord should be inspected frequently and replaced if evidence of wear or damage is observed. Replace the cord only with the power cord specified in the repair parts section of this manual. Do not allow the insert to sit for long periods with ashes in it. Ashes combined with moisture in the air can be corrosive to the metal.

This insert is equipped with a high temperature resistant glass panel in the feed door. The glass may be cleaned when it is cool with a household glass cleaner. Take care to avoid chipping or scratching the glass. Chipped or scratched glass can break suddenly when heated. Do not use the insert with a broken glass panel.

Check the following items regularly during the heating season to ensure proper insert operation:

1. Condition of fuel feed door and ash removal door gaskets - replace gaskets if excessive wear is observed.
2. Condition of fuel feed door, ash removal door and shroud door latching pawls and handles - ensures that operation of the latching pawls and handles will securely close the doors. Adjust as necessary.

Because continuous thermal self-cleaning action takes place within a catalytic combustor, it requires very little maintenance. Cleaning the catalyst with plain water can reduce buildup of the catalyst-retarding chemicals. Nothing but a soft fiber brush, low pressured air or plain water should be used to clean a catalyst. For information on how to remove the catalyst refer to the following section of this manual. The ceramic unit is fragile and it should be handled with care. A soak in warm or hot (not boiling) water for 20 minutes is ideal. Then allow the catalyst to cool at room temperature and rinse at medium pressure under a faucet. Allow the catalyst to dry before reinstalling in the insert. A cleaning once every year is sufficient for most. Clean it when you have your flue system cleaned or whenever and if ever a combustor plugged.

Plugging of the combustor usually happens when the insert operator attempts to burn materials that produce large flakes of char, such as Christmas wrapping paper and cardboard. This can plug enough cells in the combustor to cause a smoke spillage problem. To help avoid combustor plugging, burn natural wood only and keep the combustors clean.

At the end of each heating season, the insert should be thoroughly cleaned of all ashes. Ashes remaining in the insert in combination with moisture in the air can cause severe corrosion of the insert. All rust spots on the insert should be wire brushed and covered with a coat of high temperature paint. If the insert is to be stored until the next heating season, be sure the storage area is dry. The insert should never be used with damaged or missing parts.

Have a qualified insert installer inspect the complete system before cold weather each year. Replace all damaged or worn parts before using the insert.

#### WHEN AND HOW TO REPLACE THE CATALYTIC COMBUSTOR(S)

Tests figures indicate that the average expected operational life of a quality catalytic combustor is about 6000 operating hours. Remember, these are average test figures; actual combustor life of your insert's catalyst may be more or less, depending on operation procedures and normal care.

Whenever a catalytic combustors stop functioning, they should be replaced as soon as possible. Indications that a catalyst has stopped functioning and needs replacing or cleaning are:

1. Sluggish heater operation.
2. Increased wood usage.
3. Increased build-up of creosote in the chimney flue liner.

It is important to periodically monitor the operation of the catalytic combustors to ensure that they are functioning properly and to determine when they need to be replaced. There are two simple ways to determine if the insert's catalytic combustor system is functioning properly. They are:

- a. Take note of the smoke exiting the chimney with a well established fire burning in the insert and the bypass damper open. If the catalytic combustor system is functioning properly, there should be a significant decrease in the amount of smoke exiting the chimney after the bypass damper is closed. Be careful not to confuse smoke with steam from wet wood.
- b. If there is a thermometer present for monitoring the insert's internal temperatures as recommended earlier, a rapid temperature rise or drop will be noticeable on the thermometer gauge when the insert's bypass damper is closed (temperature rise) or opened (temperature drop) during the burning of a well established fire if the insert's catalytic combustor system is functioning properly.

If you suspect that your insert needs new combustors, discuss the problem with your insert heater dealer. You may only need to clean the old combustors and change some operating habits.

When you do have to replace the combustors or just remove them for cleaning, here's how it's done:

1. Allow any fire in the insert to burn out and the insert to cool.
2. Disconnect the insert blower's power cord from its power source.
3. Make the necessary disconnections to allow the insert to be pulled from the fireplace.
4. Take precautions to avoid scratching the fireplace hearth and pull the insert out of the fireplace a sufficient distance to allow access to the insert's flue outlet.
5. Reach through the flue outlet and lift out the catalyst cover plate which rests over the insert's three combustors. If there is a thermometer probe present (see figure 10), it too should be removed.
6. Remove the three combustors from the insert by lifting them up and out through the flue outlet of the insert. The combustors are wrapped in ceramic fiber insulating material and are supported by two supports; the insulating material and the supports must also be removed along with the combustors. Care should be taken not to drop the combustors because they are made of ceramic material which can break.
7. Once removal is completed, inspect for residue where the combustors were housed in the insert. Wipe this area clean with a dry cloth. **DO NOT USE DETERGENTS, STEEL OR METALLIC BRUSHES OR SOLVENTS.**