

# OWNER'S MANUAL

## NCA 1

### NONCATALYTIC WOOD BURNING RADIANT HEATER

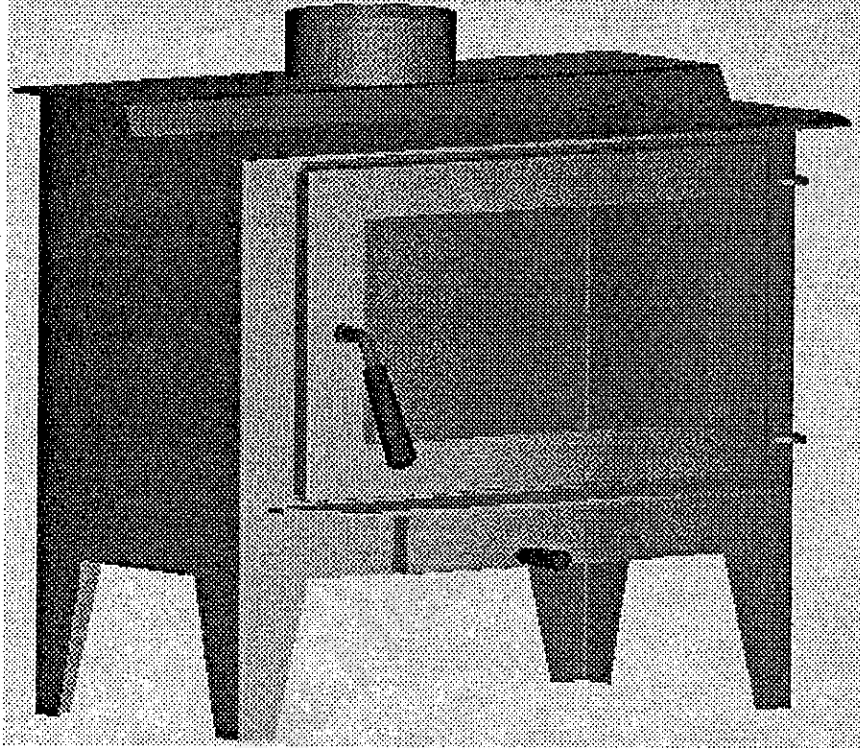

\*PICTURE MAY VARY FROM ACTUAL UNIT.

DESIGNED FOR INSTALLATION IN RESIDENTIAL TYPE HOMES AND MOBILE HOMES. FOLLOW THE APPLICABLE INSTRUCTIONS IN THIS MANUAL.

THIS HEATER MEETS EPA PARTICULATE MATTER (SMOKE) CONTROL REQUIREMENTS FOR NONCATALYTIC WOOD HEATERS BUILT ON OR AFTER JULY 1, 1990.

UNDER SPECIFIC TEST CONDITIONS THIS HEATER HAS BEEN SHOWN TO DELIVER HEAT AT RATES RANGING FROM 6,500 TO 23,200 BTU'S PER HOUR.

#### **CAUTION!**

**Read All Instructions Carefully Before Starting The Installation or Operating This Heater.**

**Improper Installation Could Void Your Warranty!**

#### **SAFETY NOTICE:**

**If this heater is not properly installed, a house fire may result. For your safety, follow the installation instructions. Contract local building or fire officials about restrictions and installation requirements in your area.**

#### **SAVE THIS MANUAL FOR FUTURE REFERENCE**

**THIS MANUAL WILL HELP YOU TO OBTAIN EFFICIENT, DEPENDABLE SERVICE FROM THE HEATER, AND ENABLE YOU TO ORDER REPAIR PARTS CORRECTLY. KEEP IN A SAFE PLACE FOR FUTURE REFERENCE.**



**UNITED STATES STOVE COMPANY**

227 Industrial Park Road  
P.O. Box 151  
South Pittsburg, TN 37380  
(423) 837-2100

**KEEPING AMERICA WARM SINCE 1869**

**ASHLEY**

851422A 11/00

---

## TABLE OF CONTENTS

---

SAFETY PRECAUTIONS .....	3
SAFETY STANDARDS AND BUILDING CODES .....	3
UNPACKING AND INSPECTION .....	3
<b>SECTION 1 ... PREPARATIONS AND INSTALLATION OF HEATER</b>	
TOOLS AND SUPPLIES NEEDED FOR INSTALLATION.....	3
MATERIALS NEEDED FOR PROPER INSTALLATION OF HEATER.....	4
IN A RESIDENTIAL TYPE HOME.....	4
IN A MOBILE HOME.....	4
SELECTING A LOCATION FOR THE HEATER.....	5
MASONRY CHIMNEY REQUIREMENTS.....	5
CONNECTION OF CHIMNEY CONNECTOR TO A MASONRY CHIMNEY THROUGH A COMBUSTIBLE WALL.....	7
CONNECTION OF CHIMNEY CONNECTOR TO A MASONRY CHIMNEY WHEN CHIMNEY CONNECTOR DOES NOT PASS THROUGH A COMBUSTIBLE WALL.....	9
CONNECTION OF HEATER TO A MASONRY FIREPLACE.....	10
METAL PREFABRICATED CHIMNEY REQUIREMENTS.....	10
METAL PREFABRICATED CHIMNEY INSTALLATION.....	10
HEATER INSTALLATION.....	13
MINIMUM CLEARANCES TO COMBUSTIBLE WALLS AND CEILINGS.....	13
TO INSTALL THE HEATER.....	14
<b>SECTION 2 ... HOW TO USE THE HEATER</b>	
SAFETY REMINDERS.....	17
HEATER OPERATION.....	17
HOW THIS HEATER OPERATES.....	17
WOOD FACTS.....	17
TO BUILD A FIRE.....	18
FIRE TENDING.....	19
ASHES - REMOVAL AND DISPOSAL.....	19
<b>SECTION 3 ... CARE OF THE HEATER AND ITS VENTING SYSTEM</b>	
VENTING SYSTEM CARE.....	20
CREOSOTE - FORMATION AND NEED FOR REMOVAL.....	20
CHIMNEY CONNECTOR PIPE - CORROSION INSPECTION.....	20
SPARK ARRESTERS AND CHIMNEY CAPS.....	20
HEATER CARE.....	21
TROUBLESHOOTING.....	22
WARRANTY CLAIM INFORMATION AND REPAIR PARTS.....	22
HEATER REPAIR PARTS LIST AND DIAGRAM.....	23
FEED DOOR ASSEMBLY PARTS LIST AND DIAGRAM.....	24

---

## **SAFETY PRECAUTIONS**

---

PLEASE READ THIS ENTIRE MANUAL BEFORE YOU INSTALL AND USE YOUR NEW HEATING APPLIANCE. FAILURE TO FOLLOW INSTRUCTIONS MAY RESULT IN PROPERTY DAMAGE, BODILY INJURY, OR EVEN DEATH.

THIS HEATING APPLIANCE SHOULD BE INSTALLED ONLY BY AN EXPERIENCED WOOD HEATER INSTALLER. IF THIS

HEATING APPLIANCE IS NOT PROPERLY INSTALLED, A HOUSE FIRE MAY RESULT. TO REDUCE THE RISK OF FIRE, FOLLOW THE INSTALLATION INSTRUCTIONS. CONTACT LOCAL BUILDING OR FIRE OFFICIALS ABOUT RESTRICTIONS AND INSTALLATION INSPECTION REQUIREMENTS IN YOUR AREA.

THIS HEATING APPLIANCE IS DESIGNED TO BURN NATURAL WOOD. IT IS NOT DESIGNED TO BURN ARTIFICIAL LOGS, PROCESSED FUELS, COAL CHARCOAL, PLYWOOD, TRASH, GARBAGE, WRAPPING PAPER, PREFORMED WOOD, TREATED WOOD, OR FLAMMABLE FLUIDS. THESE PROHIBITED FUELS MAY CAUSE THE APPLIANCE AND CHIMNEY TO DANGEROUSLY OVERHEAT OR RELEASE POISONOUS GASES. BURN NATURAL WOOD ONLY.

INSTALL SMOKE DETECTORS IN YOUR HOME. EACH SMOKE DETECTOR SHOULD BE INSPECTED REGULARLY AND KEPT IN GOOD WORKING CONDITION.

SAVE THESE INSTRUCTIONS. THESE INSTRUCTIONS SHOULD BE REVIEWED BY ALL FUTURE USERS OF THIS HEATING APPLIANCE TO ENCOURAGE ITS PROPER OPERATION AND MAINTENANCE.

---

## **SAFETY STANDARDS AND BUILDING CODES**

---

This appliance has been safety tested in accordance with UL safety standard 1482 by Warnock Hersey, a company in the Quality Systems Division of Intertek Testing Services which is an international conformity assessment organization with North American headquarters and offices worldwide. The Warnock Hersey listing mark on this appliance signifies that the design and manufacturing of this appliance comply with Intertek Testing Services' comprehensive safety assessment standards for solid fuel type room heaters. (There may be additional requirements to be met in order to comply with local building codes or regulations. Before installing this appliance, check with building or fire officials to assure compliance with local codes and regulations.)

---

## **UNPACKING AND INSPECTION**

---

Unpack the heater and inspect it thoroughly for missing parts or shipping damage. If any damage or missing parts are detected, report it to your heater dealer. DO NOT INSTALL OR USE A DAMAGED OR INCOMPLETE HEATER. See pages 24 and 25 for heater parts.

## **SECTION 1**

### **PREPARATIONS AND INSTALLATION OF HEATER**

---

#### **TOOLS AND SUPPLIES NEEDED FOR INSTALLATION**

---

pencil	drill	adjustable wrench
ruler or measuring tape	drill bits	saw*
screwdriver	furnace cement	
No. 8 sheet metal screws	rags or paper towels	

\*If the heater is being installed in a mobile home.

## MATERIALS NEEDED FOR PROPER INSTALLATION

### IN A RESIDENTIAL TYPE HOME

THE FOLLOWING MATERIALS ARE NEEDED TO PROPERLY INSTALL THIS HEATER IN A RESIDENTIAL TYPE HOME.

1. **Chimney Connector (also known as flue pipe):** The chimney connector joins the heater to the chimney. The chimney connector pipes should be 6-inches in diameter single wall 24-gauge minimum black or blued steel. (Note: The number of 90 degree bends in the chimney connector installation for appliances, such as this heater, which have a top exit flue collar should be restricted to one. More than one 90 degree bend in the chimney connector could negatively affect chimney draft.)
2. **Chimney:** A code-approved masonry fireplace or a code approved masonry chimney. See the "MASONRY CHIMNEY REQUIREMENTS" portion of this manual for details.

OR

A chimney complying with the requirements for Type HT-103 chimneys in the Standard for Chimneys, Factory Built, Residential Type and Building Appliance, UL 103. See the "METAL PREFABRICATED CHIMNEY REQUIREMENTS" portion of this manual for details.

3. **Wall Thimble:** A manufactured or site constructed device installed in combustible walls through which the chimney connector passes to connect to a masonry chimney. The wall thimble is intended to keep walls from igniting. A wall thimble is needed only if the chimney connector must pass through a combustible wall between the heater and the masonry chimney. See Figure 5 for wall thimble options.
4. **Floor Protector:** If the floor on which the heater is to be installed is wood or any other combustible material, the heater must be placed on a floor protector. The floor protector is to prevent the floor from catching fire from sparks or embers that might escape the heater or drop from the joints of the chimney connector pipe. The floor protector must protect the floor beneath and around the heater and chimney connector pipe as shown in Figure 9. The floor protector for this heater may be larger than the floor protector shown in Figure 9 but it must not be smaller than the floor protector shown in Figure 9. The floor protector must be a listed floor protector or a floor protector made of noncombustible inorganic material equal to or better than 3/8-inch thick material having a thermal conductivity K factor of 0.43.
5. **Chimney Shield:** See step 14 of the "TO INSTALL THE HEATER" portion of this manual for details.

### IN A MOBILE HOME

THE FOLLOWING MATERIALS ARE NEEDED TO PROPERLY INSTALL THIS HEATER IN A MOBILE HOME.

1. **Chimney Connector (also known as flue pipe):** The chimney connector joins the heater to the chimney. The chimney connector pipes should be 6-inches in diameter double wall listed HT-103 chimney connector pipe by Jack-Evans, Metivent, Dura-Plus, Dura-Vent DVL, or Ameri-Vent DBST. (NOTE: The number of 90 degree bends in the chimney connector installation for appliances, such as this heater, which have a top exit flue collar should be restricted to one. More than one 90 degree bend in the chimney connector could negatively affect chimney draft.)
2. **Chimney:** A chimney complying with the requirements for HT-103 chimneys in the Standard of Chimneys, Factory-Built, Residential Type and Building Heating Appliance, UL 103. See the METAL PREFABRICATED CHIMNEY REQUIREMENTS\* portion of this manual for details.
3. **Floor Protector:** If the on which the heater is to be installed is wood or any other combustible material, the heater must be placed on a floor protector. The floor protector is to prevent the floor from catching fire from sparks or embers that might escape the heater or drop from the joints of the chimney connector pipe. The floor protector must protect the floor beneath and around the heater and chimney connector pipe as shown by Figure 9. The floor protector for this heater may be larger than the floor protector shown in Figure 9 but it must not be smaller than the floor protector shown in Figure 9. The floor protector must be a listed floor protector or a floor protector made of noncombustible inorganic material equal to or better than 3/8-inch thick material having a thermal conductivity K factor of 0.43.
4. **Chimney Shield:** See step 14 of the "TO INSTALL THE HEATER" portion of this manual for details

# MOUNTING CAST-IRON FLUE COLLAR

Peel off tape from the back of the gasket and attach the gasket to the heater top around the flue collar opening.

Mount flue collar to the top of the heater using the (3) 5/16-18 x 1-1/2" Bolts and the (3) Weld tabs provided in the parts bag.

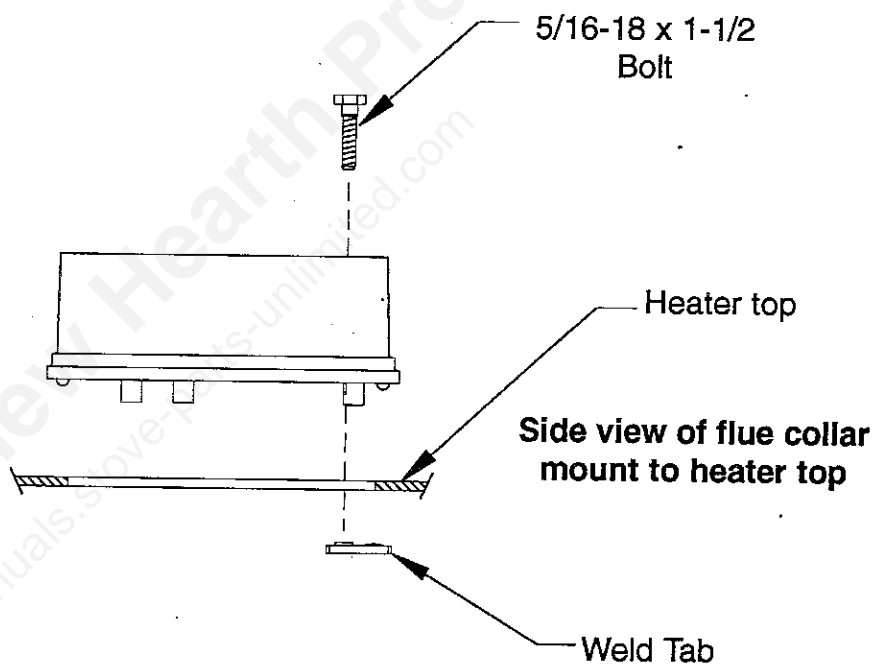

## SELECTING A LOCATION FOR THE HEATER

1. When locating the heater, consider safety, convenience, traffic flow, and the fact that the heater will need a chimney, chimney connector, and possibly a floor protector. If the heater is to be installed in a mobile home, an inlet air kit and heater hold down brackets will also be needed. Make sure none of these materials will be obstructed.
2. The heater should be located away from door ways and central heat outlets to reduce the chances of drafts, blowing smoke, ashes or sparks out of the heater during refueling or ash removal.
3. The heater should be located in an open area to allow for necessary clearances as specified within this manual.
4. Keep furniture, drapes, curtains, wood, paper and other combustibles far away from the heater.
5. Never install the heater in locations where gasoline, kerosene, charcoal lighter, or any other flammable liquids are used.
6. The heater should be located where a small supply of wood may be kept conveniently close but not within 36-inches of the heater.
7. The heater should not be located beneath overhanging shelves, low ceilings or other structures or elevated so that less clearance is created above the heater than is provided than when the heater is normally installed in a room with a 7 foot minimum ceiling.
8. Be sure the chimney will be at least 10 feet from flammable gas or liquid storage tanks.

**WARNING: DO NOT INSTALL THIS HEATER IN SLEEPING QUARTERS OF A MOBILE HOME.**

**CAUTION: WHEN THIS HEATER IS INSTALLED IN A MOBILE HOME, THE STRUCTURAL INTEGRITY OF THE MOBILE HOME FLOOR, WALL, AND CEILING/ROOF MUST BE MAINTAINED.**

**DANGER: DO NOT CONNECT THIS HEATER TO A CHIMNEY FLUE SERVING ANOTHER APPLIANCE. THERE IS A SERIOUS SAFETY RISK IF TWO APPLIANCES ARE CONNECTED TO THE SAME CHIMNEY FLUE.**

## MASONRY CHIMNEY REQUIREMENTS

If the heater is to be connected to a masonry chimney, the heater should not be installed until it is determined that the chimney is safe for use. Before installing the heater, have the chimney inspected by a building inspector, fire department, or qualified heating engineer. To prevent risk of walls, roof, or other combustibles catching fire from the extremely hot fire, smoke, and flue gases, and to obtain a proper draw, a chimney must meet the minimum standards for masonry chimneys established by the National Fire Protection Association (NFPA). Make certain the inspection agency is familiar with NFPA No. 211 and all local codes. Some of those minimum standards are listed here for your convenience.

1. The chimney must not be obstructed or clogged. An obstructed or clogged chimney could cause smoke and the dangerous carbon monoxide in smoke to spill back into your home.
2. Your masonry chimney must be supported on an adequate foundation and must have either a 5/8" thick fireclay or stainless steel lining. There must be at least 1/2-inch air space between the flue liner and the chimney wall. (See Figure 1.)
3. A chimney inside the house must have at least 2 inches of clearance to the combustible structure. A chimney outside the house must have at least 1 inch clearance to the combustible structure. Fire stops must be installed at the spaces where the chimney passes through floors and/or ceilings. (See Figure 2.) Insulation should be at least 2 inches from the chimney to leave an air space around the chimney. (See Figure 3.)
4. The flue lining of a masonry chimney must be smooth and have no leaks. The inside of the chimney flue liner should be no smaller than 8 inches square or 6 inches round; a smaller chimney flue liner will be too restrictive to the flow of smoke and gases. A 6 inch diameter round liner is preferred because round flues draw better than square flues.
5. Since an oversized chimney flue contributes to the accumulation of creosote, the size of the chimney flue liner must be checked to determine that it is not too large for the heater. For this heater, the inside cross-sectional area of the chimney should be no more than 85 square inches to assure proper venting.
6. The top of the chimney must be at least 3 feet above the point where it comes through the roof, and at least 2 feet higher than any obstruction within a 10 foot radius. (See Figure 4.)
7. If the heater has insufficient draft, the draft may be improved by extending the height of the chimney.
8. Make certain the chimney is kept clean and it is not blocked. Check for limbs overhanging the top of the chimney periodically.

**FIGURE 1 -  
MASONRY CHIMNEY  
REQUIREMENTS**

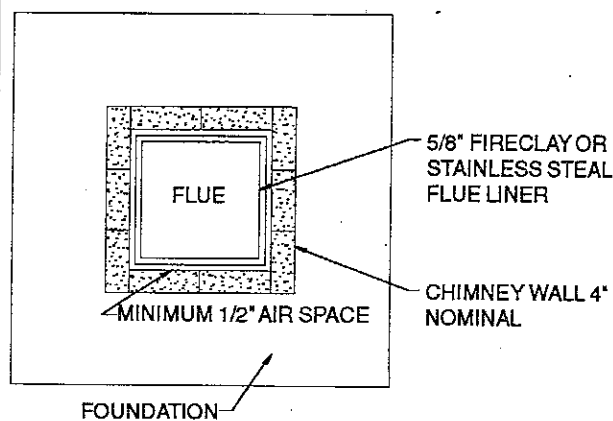

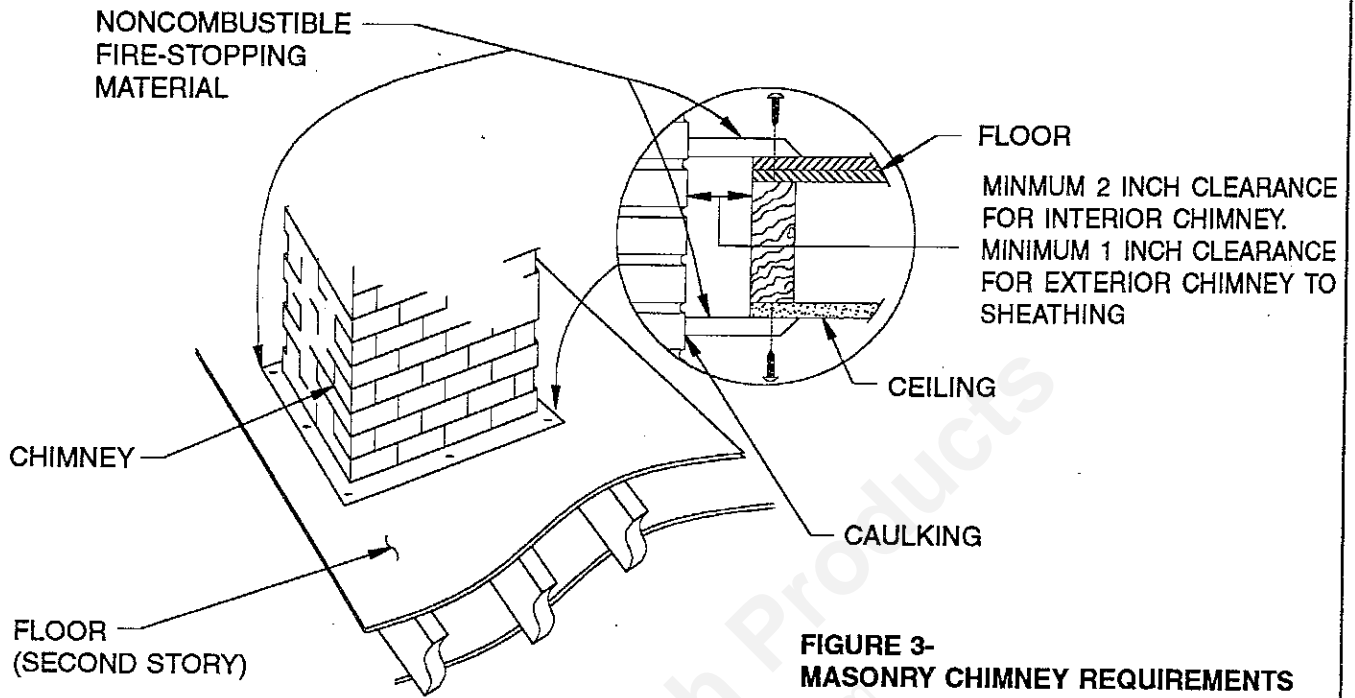

**FIGURE 3-  
MASONRY CHIMNEY REQUIREMENTS**

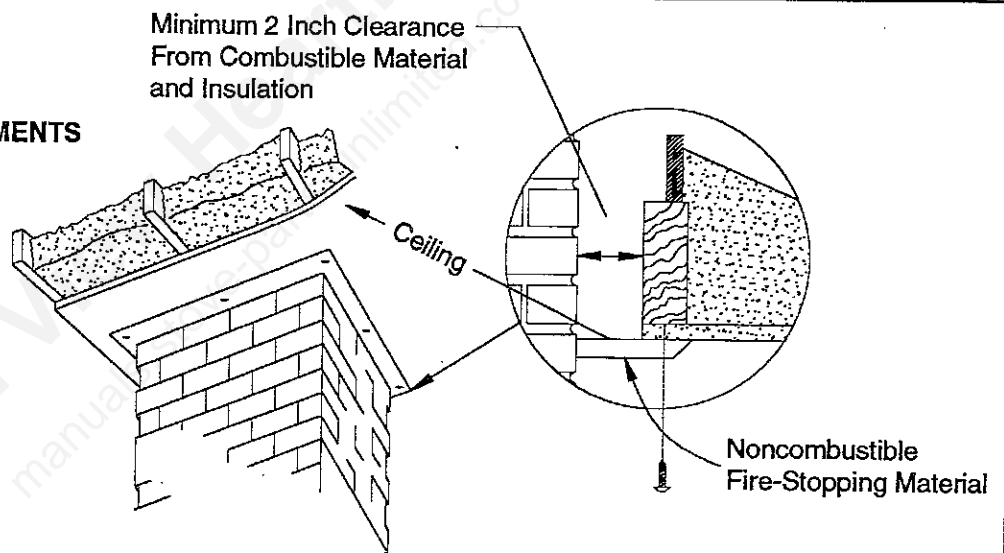
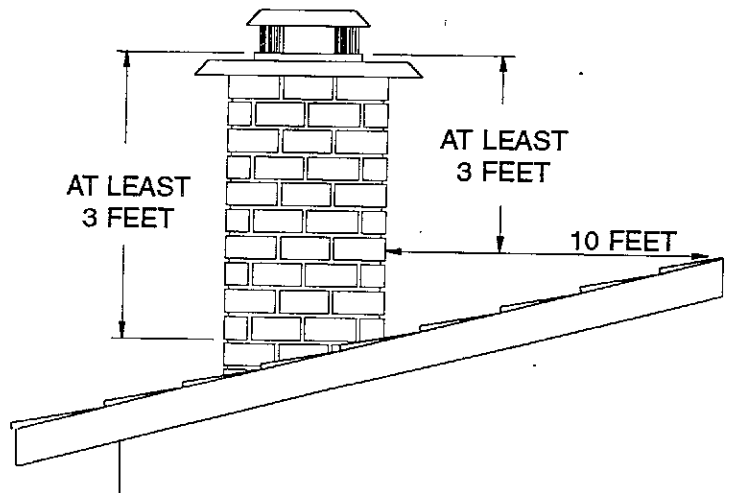

**FIGURE 4-  
CHIMNEY HEIGHT REQUIREMENTS**

A Chimney must be the required height above the roof or other obstruction for safety and for proper draft operation. The requirement is that the chimney must be at least 3 feet higher than the highest point where it passes through the roof and at least 2 feet higher than the highest part of the roof or structure that is within 10 feet of the chimney, measured horizontally.

The above chimney heights are the minimum required by codes for safety purposes to allow sparks existing in chimney time to cool before they land on the roof. Additional height will generally increase draft, improve heater operating characteristics and reduce back drafting and puffing problems due to wind

A masonry chimney is shown above. However, height requirements are the same for a metal prefabricated chimney.



## CONNECTION OF CHIMNEY CONNECTOR TO A MASONRY CHIMNEY THROUGH A COMBUSTIBLE WALL

Figure 5 shows how to connect the chimney connector of a heater to a masonry chimney through a combustible wall.

There are five allowable ways that a chimney connector can be connected to a masonry chimney by passing through a combustible wall. NFPA Standard 211 allows the following wall pass-through systems.

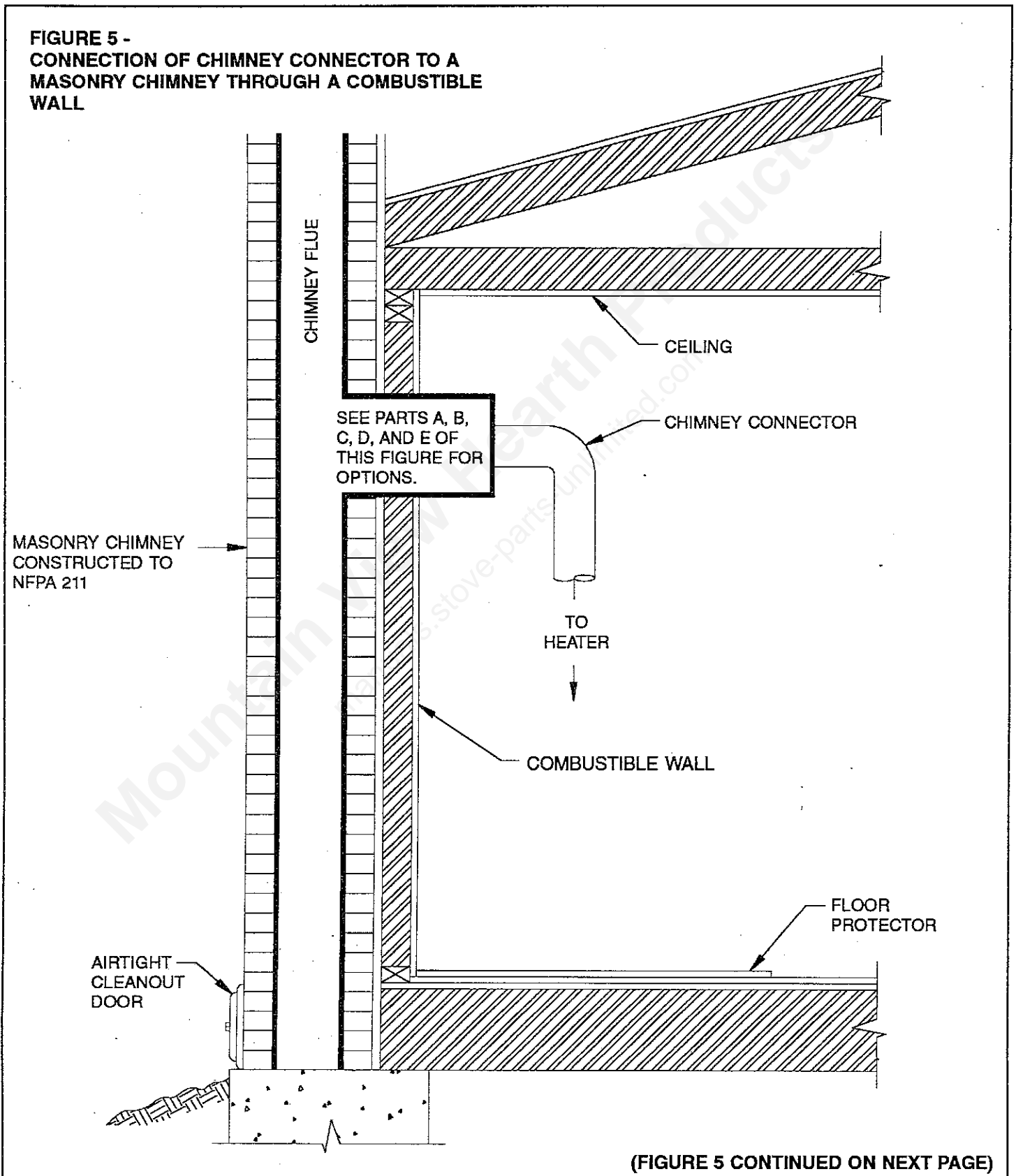

**PART A, FIGURE 5**  
(FIGURE 5 CONTIUED ON NEXT PAGE)

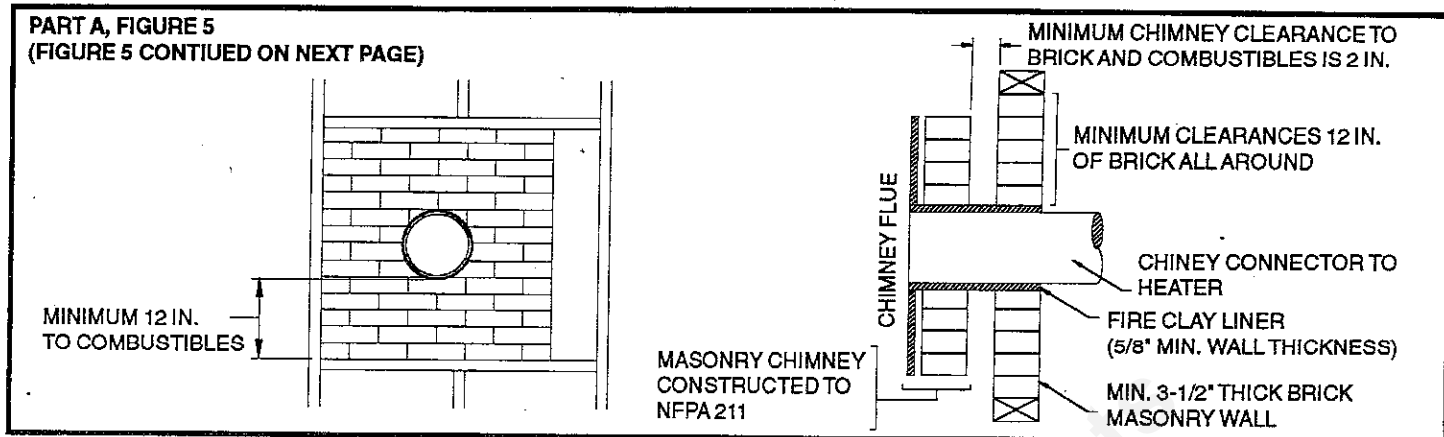

1. Use a minimum 3-1/2" thick brick masonry wall framed into the combustible wall. A fireclay liner (ASTM C315 or equivalent) having a 5/8" minimum wall thickness must be used and it must be at least 12" away from any material that could catch fire. The inside diameter of the fireclay liner shall be sized for the proper snug fit of a 6" diameter chimney connector pipe. The fireclay liner shall run from the outer surface of the brick wall to, but not beyond, the inner surface of the chimney flue and shall be firmly cemented in place. See Part A of Figure 5.
2. Use a solid insulated listed factory-built chimney length having an inside diameter of 6" and having 1" or more of solid insulation. There must be at least a 9" air space between the outer wall of the chimney length and any combustible materials. The inner end of the chimney length shall be flush with the inside of the masonry chimney flue and shall be sealed to the flue and to the brick masonry penetration with nonwater-soluble refractory cement. Sheet steel supports which are at least 24 gauge (0.024") in thickness shall be securely fastened to wall surfaces on all sides. Fasteners between supports and the chimney length shall not penetrate the chimney liner. See Part B of Figure 5.
3. Use a 10" diameter ventilated thimble made of at least 24 gauge (0.024") steel having two 1" air channels. The ventilated thimble must be separated from combustible materials by a minimum of 6" glass fiber insulation. The opening in the combustible wall shall be covered and the thimble supported with sheet steel supports which are at least 24 gauge (0.024") in thickness. The sheet steel supports shall be securely fastened to wall surfaces on all sides and shall be sized to fit and hold the chimney section. Fasteners used to secure chimney sections shall not penetrate chimney flue liner. See Part C of Figure 5.
4. Use an 8" inside diameter solid insulated listed factory-built chimney length which has 1" or more of solid insulation. The minimum length of this chimney section shall be 12" and will serve as a pass-through for the 6" diameter chimney connector. There must be at least a 12" air space between the outer wall of the chimney section and any combustible materials. The chimney section shall be concentric with and spaced 1" away from the chimney connector by means of sheet steel support plates on both ends of the chimney section. The opening in the combustible wall shall be covered and the chimney section supported on both sides with sheet steel supports which are at least 24 gauge (0.024") in thickness. The sheet steel supports shall be securely fastened to wall surfaces on all sides and shall be sized to fit and hold the chimney section. Fasteners used to secure chimney sections shall not penetrate chimney flue liner. See Part C of Figure 5.
5. A listed factory-built wall pass-through system may be purchased and installed according to the instructions packaged with it to provide a safe method of passing the chimney connector through a combustible wall for connection to a masonry chimney.

Additional requirements pertaining to Figure 5 and the above wall pass-through systems:

1. Insulation material used as part of wall pass-through system shall be of noncombustible material and shall have a thermal conductivity of 1.0 Btu • in./ft.<sup>2</sup> • °F (4.88 kg • cal/hr • m<sup>2</sup> • °C) or less
2. All clearances and thicknesses are minimums: larger clearances and thickness are acceptable.
3. A chimney thimble, as shown for 3" and 4" above (Parts C and D respectively of Figure 5) shall be for types "3" and "4" connections to facilitate removal of the chimney connector for cleaning. The chimney thimble shall be of ASTM C315 fireclay with 5/8" minimum wall thickness, or material of equivalent durability. The inside diameter of the thimble shall be sized for the proper snug fit of a 6" diameter chimney connector pipe. The thimble shall be installed without damage to the chimney flue. The thimble shall extend through the chimney wall to, but not beyond, the inner surface of the chimney flue and shall be permanently cemented in place with high temperature cement.
4. A chimney connector to a masonry chimney, except for 2" above (Part B of Figure 5), shall extend through the wall pass-through system to the inner face of the chimney flue, but not beyond. It does not have to be fastened in place so long as it cannot accidentally be pulled out of the chimney or shoved into the chimney flue. If fasteners are used to secure the chimney connector to a masonry chimney, the fasteners shall not penetrate the chimney flue liner.
5. Any material used to close up any opening for the connector shall be noncombustible.

**FIGURE 5 -  
METAL PREFABRICATED CHIMNEY INSTALLED INSIDE THE RESIDENCE THROUGH THE  
CEILING AND THE ROOF**

INSTALL AN INSULATION SHEILD TO MAINTAIN THE SPECIFIED CLEARANCE TO INSULATIO. INSULATION IN THIS AIR SPACE WILL CAUSE A HEAT BUILDUP WHICH MAY IGNITE THE CEILING JOIST.

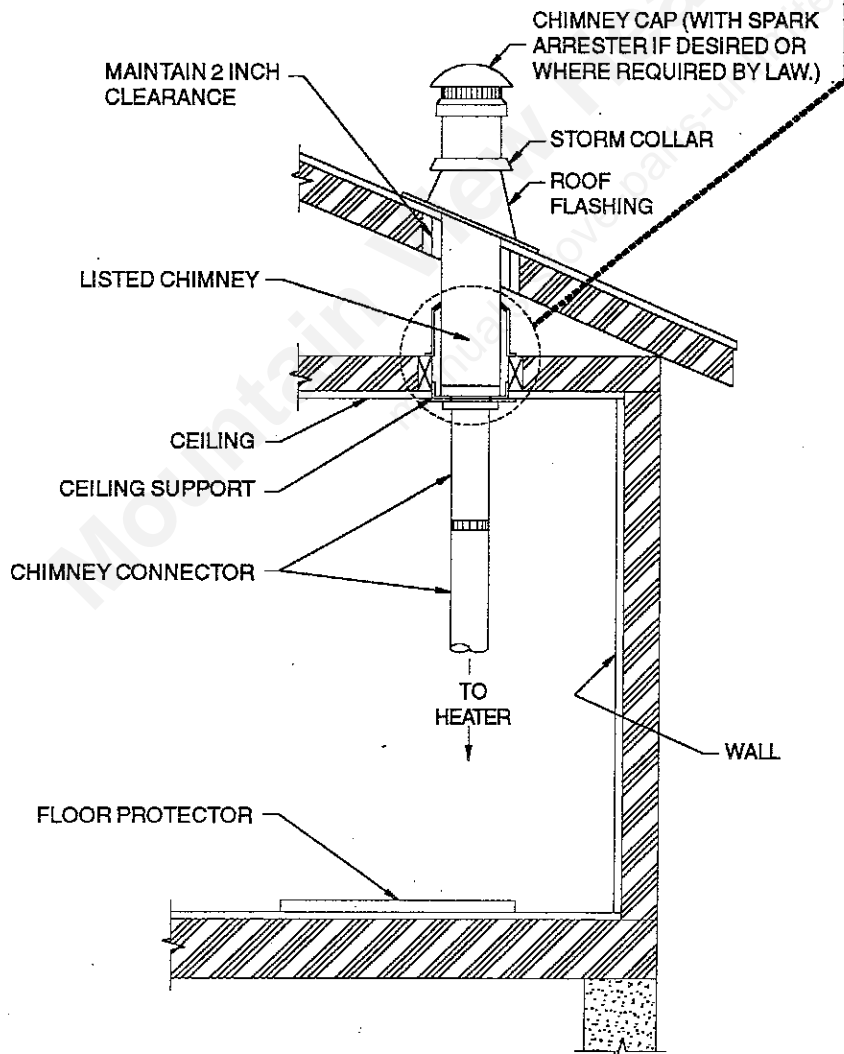
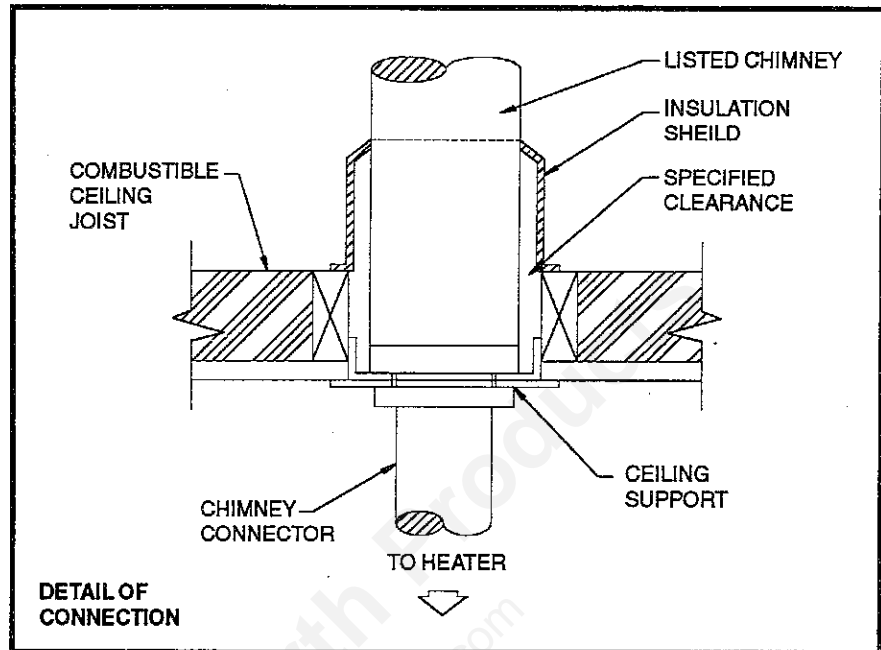

**FIGURE 7 -  
EXTERIORLY INSTALLED METAL PREFABRICATED CHIMNEY THAT RUNS UP THE OUTSIDE OF  
THE RESIDENCE.**

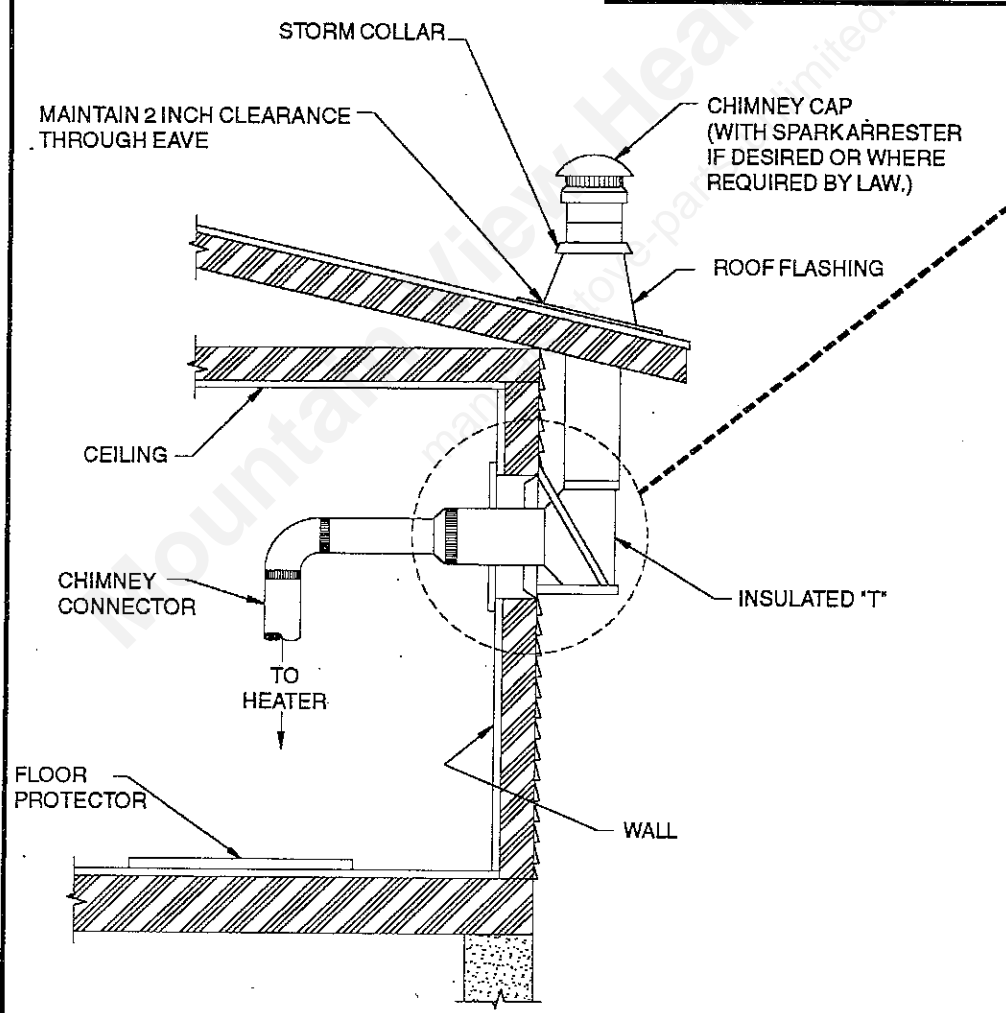
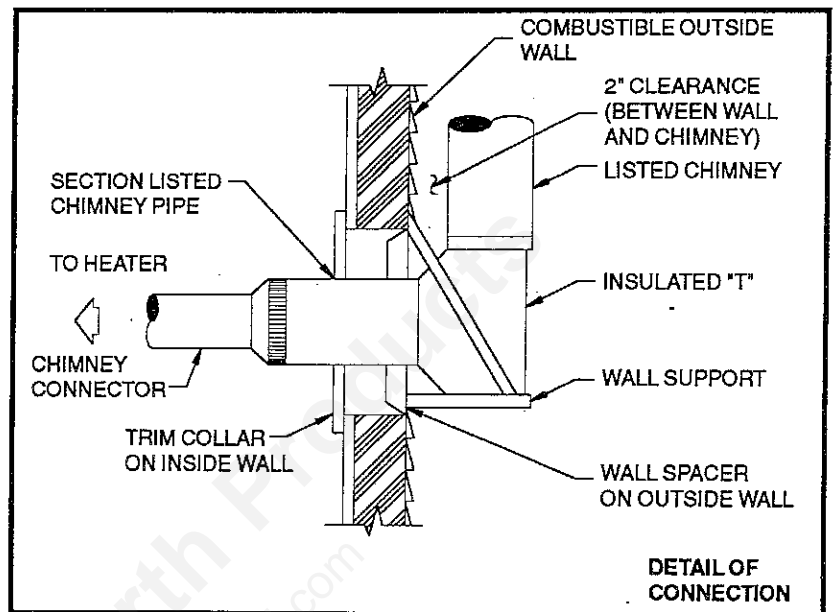

## HEATER INSTALLATION

**CAUTION:** FOR YOUR SAFETY, THE INSTALLATION OF THIS HEATER MUST COMPLY WITH LOCAL CODES AND REGULATIONS. CONTACT LOCAL BUILDING OR FIRE OFFICIALS ABOUT INSPECTION TO ASSURE PROPER COMPLIANCE WITH LOCAL CODES AND REGULATIONS.

### MINIMUM CLEARANCES TO COMBUSTIBLE WALL AND CEILINGS

**CAUTION:** MOST WALLS AND CEILINGS CONTAIN WOOD EVEN THOUGH THEY ARE MADE OF SHEETROCK OR PLASTER ON THE OUTSIDE. THESE WALLS AND CEILINGS CAN CATCH FIRE FROM THE HOT WATER HEATER OR CHIMNEY CONNECTOR IF HEATER AND CHIMNEY CONNECTOR ARE NOT PROPERLY INSTALLED.

Minimum clearances to unprotected combustible walls and ceilings as noted by Figure 8 must be maintained. Drapes, curtains, furniture and other combustible materials should be kept much further away from the heater chimney connector to avoid a fire.

**FIGURE 8 -  
MINIMUM CLEARANCES TO COMBUSTIBLE MATERIALS (IN INCHES)  
FOR CLARITY, MOBILE HOME'S PAK INLET AIR KIT NOT SHOWN.**

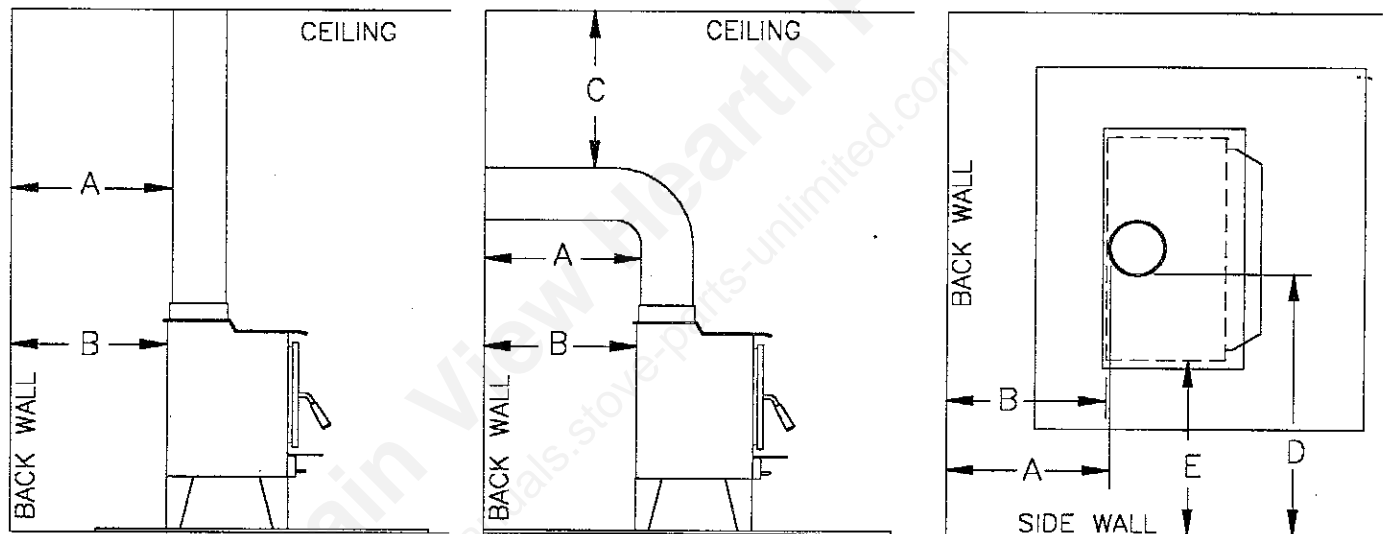

	DIM "A"	DIM "B"	DIM "C"	DIM "D"	DIM "E"
RESIDENTIAL	19"	18-1/2"	18"	30"	20-1/4"
MOBILE HOME	18"	18-1/2"	18"	29"	20-1/4"

If you choose to, you may install the heater and chimney connector closer to combustible surfaces than indicated by Figures 2 through 4 if a clearance reduction system is also installed to protect combustible ceilings and walls near the heater and chimney connector. However, there are limits to how close the heater and chimney connector can be installed to combustible surfaces protected by a clearance reduction system.

A correctly installed clearance reduction system protects the combustible surfaces well beyond the sides and above the top of the heater and beyond the sides and top of the chimney connector pipe.

Two common types of clearance reduction systems use sheet metal with a minimum thickness of 28 gauge (galvanized steel, aluminum, copper) or a 3-1/2 inch (4 inch nominal) thick masonry wall. Either of these materials must be spaced out 1 inch from the combustible surfaces. With sheet metal, non-combustible spacers are used to maintain the 1 inch air space. With a masonry wall, metal wall ties and furring strips, if needed are used to anchor the brick to the wall. To avoid excessive heat transmission, the spacers or wall ties should not be placed directly behind the heater or chimney connector. The 1 inch air space provides free air circulation. It is essential that there be openings at the top and bottom of these clearance reducers so cool air can enter at the bottom and hot air exit at the top. It is the "chimney effect" whereby when the air in the space is heated, it rises exiting from the top and being replaced by cooler air at the bottom, that makes these shields effective.

Masonry, or other non-combustible products, attached directly to a combustible surface without an air space offer very little protection and cannot be considered a clearance reducer unless specified materials have been tested and listed for direct attachment to a combustible surface. The same applies to thin veneer brick and stone coverings. These materials provide adequate protection only when mounted on sheet metal with a 1 inch spacing to the wall.

A variety of prefabricated clearance reduction systems which have been tested and listed are available through heater dealers. Always look for a safety listing label on the product when selecting a clearance reduction system and make sure it is designed for solid fuel appliances. The manufactures of these systems provide specific installation instructions that must be followed exactly for a safe installation.

Should you choose to make your own clearance reduction system, contact your local fire department, fire marshal or building code inspector for specific requirements regarding home constructed clearance reduction systems and safe installation clearances to protect combustible materials.

**CAUTION: READ ALL INSTRUCTIONS BEFORE INSTALLING THE HEATER.**

**TO INSTALL THE HEATER:**

1. Make ready a suitable chimney. The chimney must comply with the appropriate chimney requirements (presented earlier) for the type of home (residential or mobile) in which this heater is to be installed.
2. Gather the necessary materials, tools, and supplies which will be needed to install the heater.  
**CAUTION: DO NOT USE MORE THAN ONE 90 DEGREE BEND (ELBOW) IN THE CHIMNEY CONNECTOR INSTALLATION. MORE THAN ONE 90 DEGREE BEND (ELBOW) IN THE CHIMNEY CONNECTOR COULD NEGATIVELY AFFECT CHIMNEY DRAFT.**
3. If the floor on which the heater is to be installed is wood or any other combustible material, place a floor protector (described earlier) on the floor where the heater will be installed.  
**CAUTION: THE FLOOR PROTECTOR MUST NOT BE PLACED ON CARPET. REMOVE CARPET FROM BENEATH THE FLOOR PROTECTOR.**
4. Place the heater on the floor protector as shown in Figure 9.
5. Assemble the chimney connector pipe from the heater's flue collar to the chimney to determine if the chimney connector pipe will correctly extend from the heater's flue collar to the chimney. Any horizontal section of chimney connector pipe must slope upward at least 1/4-inch rise to the horizontal foot (as shown in Figure 10) to help maintain a sufficient draft. Always install the chimney connector pipe with the crimped end toward the heater (as shown in Figure 10) to prevent creosote from leaking out of the chimney connector pipe joints. **MAKE SURE CLEARANCES TO COMBUSTIBLES ARE MAINTAINED AS SPECIFIED BY FIGURE 8 IF A CLEARANCE REDUCTION SYSTEM IS NOT INSTALLED.**

**FIGURE 9 -  
PLAN VIEWS SHOWING FLOOR PROTECTOR'S MINIMUM SIZE (DIMENSIONS IN INCHES)**

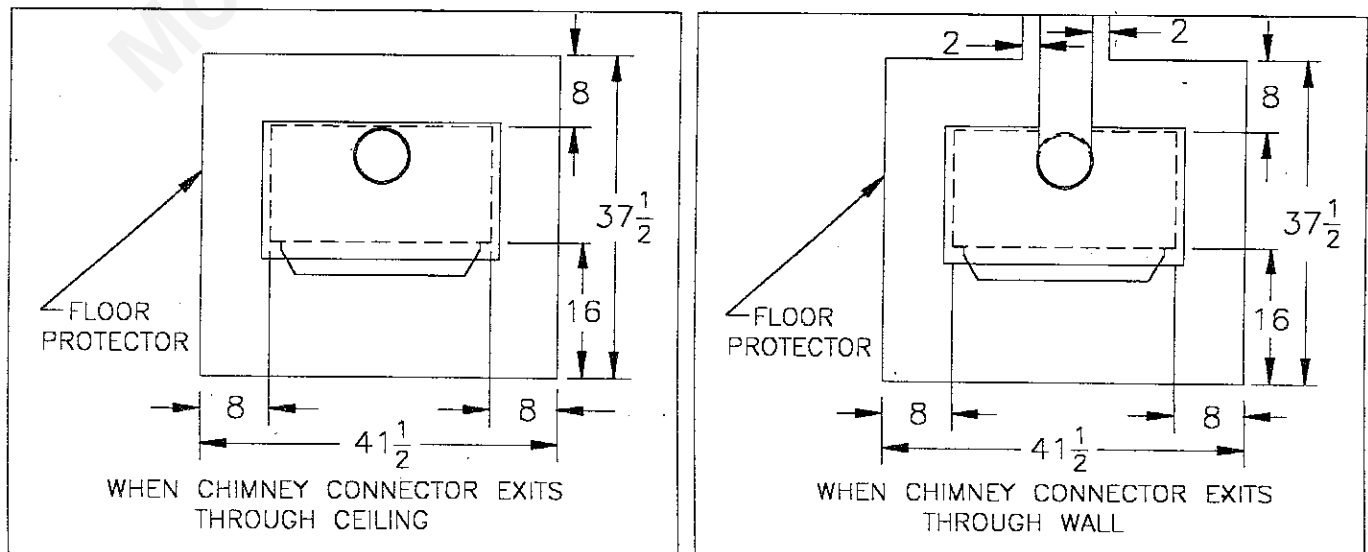

**FIGURE 10 -  
RISE OF HORIZONTAL CHIMNEY CONNECTOR PIPE**

RISE:  
1/4" FOR EACH FOOT OF  
CONNECTOR LENGTH

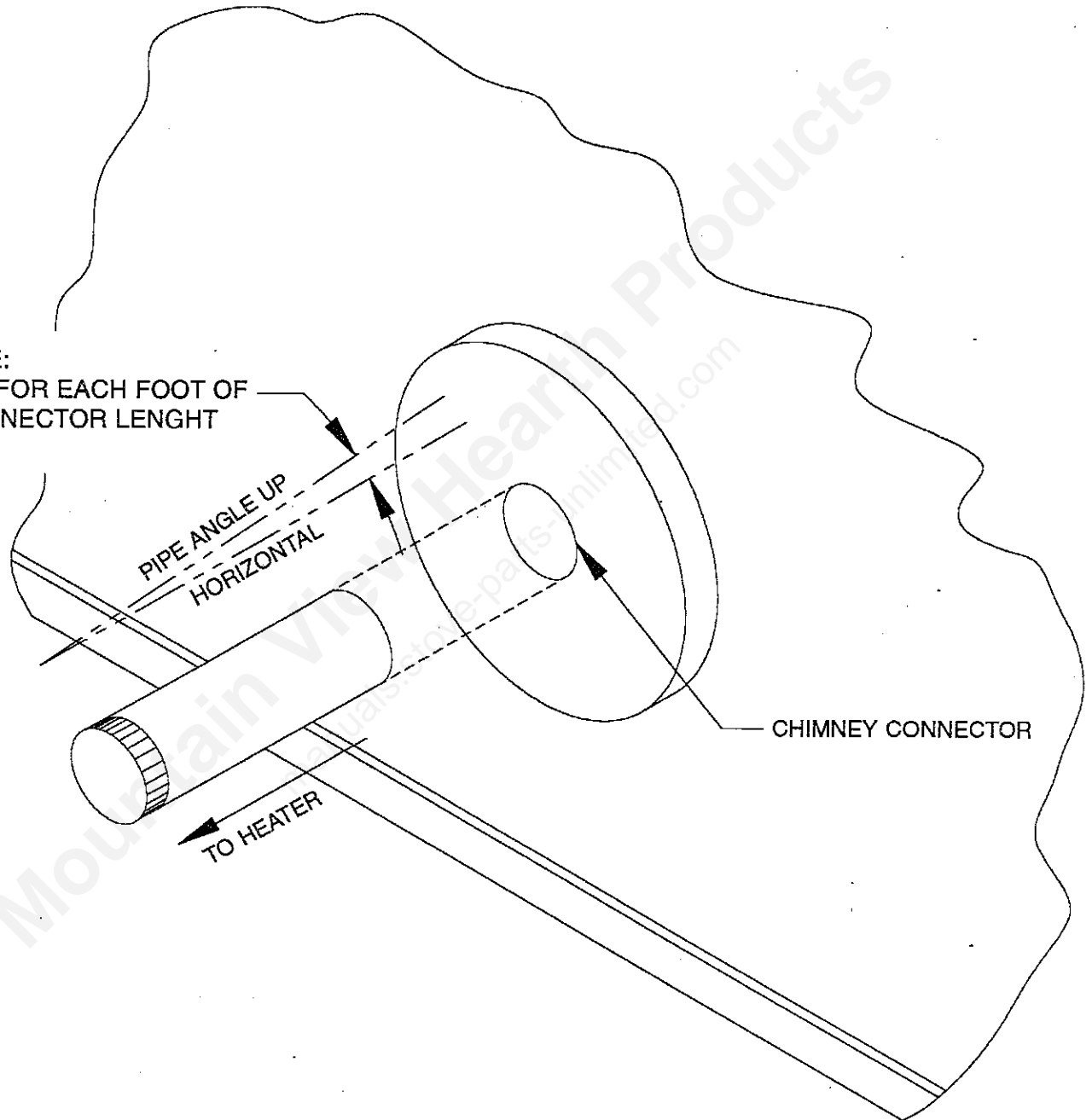

6. Place the crimped end of the first chimney pipe or elbow into the heater's flue collar and mark it through each of the holes in the heater's flue collar.
7. Remove the pipe or elbow from the flue collar and drill 1/8 - inch diameter holes at the points marked.
8. Apply the furnace to the inside surface of the heater's flue collar, reinstall the first pipe or elbow and fasten in place with No. 8 sheet metal screws. Apply additional furnace cement to the outside of the chimney connector flue collar joint if an airtight seal was achieved when the pipe or elbow was installed. Wipe all excess furnace cement from the joint with a rag or paper towel before the cement dries.
9. Assemble the remaining chimney connector pipes by apply furnace cement to the joints, drilling 1/8-inch diameter holes for and attaching each joint with three(3) No. 8 sheet metal screws. Wipe all excess furnace cement from the joints with a rag or a paper towel before the cement dries.
10. Depending on the type chimney installed, connect the chimney connector to the chimney as shown in Figure 5 or as described by the chimney's manufacturer.
11. If the chimney to which the heater is connected is a metal prefabricated chimney that exits the home at a point 7 feet or less above ground level and runs up the outside of the residence, it will be necessary to construct a chimney shield to prevent someone from coming in contact with the outer surface of the hot chimney while the heater is in operation. The shield should be constructed from wire mesh or expanded metal (22 gauge minimum) to allow air circulation around the chimney. The openings in the shield should not be large enough to allow a 1/2-inch diameter rod to pass through. The shield should have sufficient rigidity to provide the required protection and be permanently installed as shown in Figure 11.

**DANGER: IF ANY CLEARANCE TO UNPROTECTED COMBUSTIBLE WALL OR CEILING IS LESS THAN THOSE SPECIFIED BY FIGURE 8 AFTER HEATER INSTALLATION IS COMPLETED, A CLEARANCE REDUCTION SYSTEM MUST BE INSTALLED BEFORE THE FIRST FIRE IS BUILT IN THE HEATER; OTHERWISE, THE UNPROTECTED WALL OR CEILING COULD CATCH FIRE. REMEMBER, THERE ARE ALSO LIMITS AS TO HOW CLOSE THE HEATER CAN BE INSTALLED TO A COMBUSTIBLE SURFACE PROTECTED BY A CLEARANCE REDUCTION SYSTEM. RE-READ "MINIMUM CLEARANCES TO COMBUSTIBLE WALL AND CEILINGS" PRESENTED EARLIER IN THIS MANUAL.**

**FIGURE 11 -  
INSTALLATION OF CHIMNEY SHIELD**

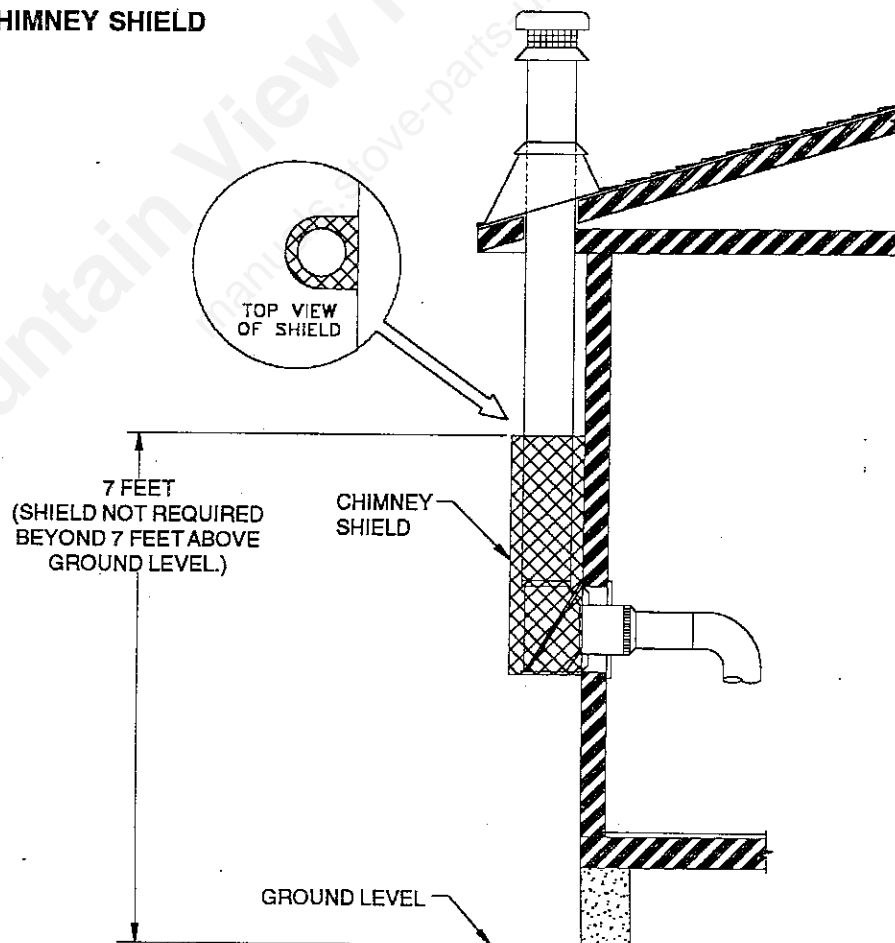

# HOW TO USE THE HEATER

---

## SAFETY REMINDERS

---

- A correctly installed heater can still pose a fire hazard if it is not used properly.
- Only after the heater is installed properly attached to an approved chimney in good condition and has been inspected by a qualified person, is it ready for operation.
- Remember not to place any combustibles too close to the heater. In addition to furniture, rugs and clothing, this includes paper that you might use to start the fire.
- Never use flammable liquids to start or freshen a fire. Gasoline, kerosene, lantern fuel and other such liquids can explode.
- Don't touch a heater to see if it is hot. Use insulated and fireproof gloves when tending the fire.
- When the heater is operating, children must be closely supervised. Unaware of the potential danger of a heater, children may accidentally bump into or touch the heater or be burned.
- Make sure you don't wear loose or flowing garments when tending the heater. Clothing like this could ignite. Be careful that hot coals don't fall on your clothing.
- To prevent asphyxiation, open a window to allow fresh air into the room when you use the heater for long periods of time.
- Do not use this heater as a trash disposal. This can cause dangerous overheating.
- Do not over fire this heater. Overfiring can cause a chimney fire or house fire. Overfiring can also shorten the life of the heater.
- Burn natural wood only in this heater. See the "WOOD FACTS" portion of this manual for detailed information.
- The small amounts of wood used for daily fire tending should be kept in a noncombustible container at least 36 inches away from the heater.
- Use only metal containers with tight fitting lids to remove ashes.
- Do not elevate the fire or use with a grate.

---

## SAFETY REMINDERS

---

### HOW THIS HEATER OPERATES

The chimney draft draws combustion air (oxygen) into the heater's firebox through an adjustable inlet air damper. The amount of combustion air allowed to be drawn into the heater is manually controlled by the inlet air cover lever located at the lower front of the heater. The gases (smoke) produced by the burning wood are consumed by the fire and burned, if there is sufficient heat and combustion air present. As the surface of the heater becomes hot, it radiates heat to the objects around it and heats air flowing by it. Any attempt to alter this flow of air by connecting this heater to a duct system can lead to improper and possibly hazardous operation of this heater.

### WOOD FACTS

As previously mentioned, only natural wood should be burned in this heater. Of course, enough newspaper to start the wood fire is acceptable.

Freshly cut natural wood contains a lot of water, as much as 50 percent water by weight; therefore, freshly cut wood is likely to produce a smoldering, smoky fire and chimney temperatures that are cool enough to cause a more rapid accumulation of a substance known as creosote. (NOTE: The hazards of creosote are described elsewhere in this manual.) To prepare freshly cut natural wood for the most economical and trouble-free burning, it should be cut, split, and stacked out of the rain with its ends exposed for at least 6 months before it is burned. Wood that has been seasoned or air-dried in this fashion is approximately 20 percent water by weight.

There are two types of natural wood: (1) Hardwood, which generally comes from deciduous, broad-leaved trees, are dense and slow to catch fire but will burn evenly for a long time once they do start burning. (2) Softwoods, burn fast, so a fire built entirely of soft wood will burn out quicker than one built entirely of hardwood.

By mixing softwoods and hardwoods, an easily ignited and long-lasting fire can be achieved.

To get an ideal of how wood is described and sold, you should first know that the most common measures in the cord. A cord is a tightly stacked pile of logs 8 feet long, 4 feet high, 4 feet deep. The logs are usually cut 2 feet long, but you can have them cut into shorter lengths. A partial cord, called a face cord or a rick, is the same length and height as a cord, but its depth can be anywhere from 1 to 3 feet.

Wood is also sold by the ton, A ton of air-dried, dense hardwood (oak, hickory, maple, etc.) is equal to approximately one-half cord.

If you buy wood by weight, look for seasoned (air dried) wood. Don't pay for extra water. NOTE: Seasoned wood will look withered and have cracked ends. The wood should be generally sound, but don't be concerned about small pockets of rot you may find.

The following chart shows the heat values (per cord) of some various species of natural woods after they have been seasoned:

TYPE	WEIGHT	PER CORD	EFFICIENCY RANKING	SPLITS	MILLIONS BTU'S / CORD
HICKORY	63	4500	1.0	WELL	31.5
WHITE OAK	48	4100	.9	FAIR	28.6
RED OAK	46	3900	.8	FAIR	27.4
BEECH	45	3800	.7	HARD	26.8
SUGAR MAPLE	44	3700	.6	FAIR	26.2
BLACK OAK	43	3700	.6	FAIR	25.6
ASH	42	3600	.5	WELL	25.0
YELLOW BIRCH	40	3400	.4	HARD	23.8
RED MAPLE	38	3200	.3	FAIR	22.6
PAPER BIRCH	37	3100	.3	EASY	22.1
ELM/SYCAMORE	34	2900	.2	VERY DIFFICULT	20.1
RED SPRUCE	29	1800	.1	EASY	16.1

### TO BUILD A FIRE

**WARNING:** THE PAINT ON THE EXTERIOR OF THE HEATER WILL GO THROUGH A CURING PROCESS DURING THE FIRST FIRING OF THE HEATER AND WILL EMIT SOME SMOKE AND ODOR. BE PREPARED FOR THIS BY RAISING A WINDOW OR OPENING A HOUSE DOOR TO PROVIDE ADDITIONAL VENTILATION.

The first time the heater is fired, the fire should be regulated so as to increase in intensity gradually to allow the paint to cure slowly and to allow the other heater components to adjust to their expanding size.

Do not use a grate or elevate fire - build wood fire directly on brick hearth in the bottom of the heater as described below.

1. Fully open the heater's inlet air damper by setting the heater's inlet air cover lever to the "HI" position.
2. Open the heater's fuel feed door and place several wadded grapefruit-size balls of newspaper on the brick hearth in the bottom of the heater.
3. Cover the balls of newspaper with dry kindling sticks. Place the kindling sticks close enough to one another so the flames can move from one stick to the other. If the kindling is packed too tightly, the fire will suffocate, smoke and then die out.  
NOTE: Softwoods make better kindling than hardwoods.
4. Light the wadded balls of paper in the heater. Leave the fuel feed door slightly ajar (approximately 1 to 2 inches) to allow plenty of oxygen to reach the fire, but DO NOT LEAVE THE HEATER UNATTENDED.

**WARNING: NEVER OR REKINDLE A HEATER FIRE WITH KEROSENE, GASOLINE, OR CHARCOAL LIGHTER FLUID: RESULTS CAN BE FATAL.**

5. Once the original kindling is well lit, add more kindling and 2 or 3 logs about three inches in diameter. Be careful not to smother the fire. Stack the new wood pieces carefully, near enough to keep each other hot, but far enough away to allow adequate air flow between them. NEVER LEAVE THE HEATER WHILE ITS FUEL FEED DOOR IS NOT SECURELY CLOSED.
6. Once the logs begin to burn, securely close the fuel feed door.

**CAUTION: OPERATING THE HEATER WITH ITS FUEL FEED DOOR CREATES AN ABNORMAL FIRING CONDITION WHICH CAN OVERHEAT THE HEATER, CHIMNEY AND ADJACENT COMBUSTIBLE MATERIALS. OPERATING THE HEATER WITH ITS FUEL FEED DOOR OPEN CAN DRASTICALLY SHORTEN THE LIFE OF THE HEATER AND VOID THE HEATER'S FACTORY WARRANTY.**

7. When the wood in the heater is burning well, add more wood in following sequence:
  1. Make sure the heater's inlet air damper is fully open, then open the heater's fuel feed door.
  2. Add more logs. (Large logs burn slowly, holding a fire longer. Small logs burn fast and hot, giving quick heat.
  3. Securely close the heater's fuel feed door.
8. Once the load of wood begins to burn well, adjust the heater's inlet air damper to establish the heat output and burn rate desired. (NOTE: The more closed the damper is, the lower and slower the fire will burn; the more open the damper is, the hotter and faster the fire will burn.

How long a load of wood will burn will vary due to such variables as the type wood being burned, how well the wood is seasoned, position of the heater's inlet air damper, the position of the heater in the house and how well the house is insulated.

A good bed of hot coals will maintain a more even temperature as well as get a new load of wood burning easily.

## **FIRE TENDING**

Fire tending is the occasional poking or stirring of the burning fuel bed to assure airflow through the fire and adding new wood as needed. With experience, you should determine how often fire tending is required to maintain the desired heat output of the heater. To ensure safe and satisfactory performance of the heater, the following rules should be observed during fire tending:

1. **KEEP THE FUEL FEED DOOR CLOSED EXCEPT WHEN TENDING THE FIRE OR REMOVING ASHES FROM THE HEATER.** Operating the heater with its fuel feed door open can cause the heater to overheat and will increase possibility of smoke, ash or sparks escaping the heater and damaging the dwelling or its contents.
2. **DO NOT ADD TOO MUCH WOOD AT ONE TIME WHEN REFUELING.** Adding large amounts of wood can cause an accumulation of unburned gases above the fire and could result in backpuffing. Backpuffing is the sudden ignition of accumulated gases inside the heater when air is suddenly mixed with the gases. Such as when the heater's fuel feed door is opened. Backpuffing may cause smoke and flames to be expelled from any available opening in the heater. Also, adding large amounts of water vapor up the chimney; this can cause a very rapid accumulation of creosote.
3. **TO PREVENT SMOKE AND POSSIBLY FLAMES FROM SPILLING OUT OF THE HEATER, THE FOLLOWING SEQUENCE SHOULD ALWAYS BE FOLLOWED WHEN OPENING THE HEATER'S FUEL FEED DOOR TO TEND THE FIRE:**
  1. Fully open the inlet air damper by setting the heater's air inlet cover lever to the "HI" position.
  2. Wait about one minute, then open the fuel feed door. Keep your face well back from the fuel feed door until the door has been fully open for a few seconds.
4. **DO NOT OVERFIRE THE HEATER.** If any part of the chimney connector or heater glows red hot, move the heater's inlet air control lever to "LO" and keep the heater's door closed until the heater cools.
5. **BEFORE THE HEATER IS LEFT UNATTENDED AFTER ADDING FRESH WOOD,** the fire should be well established and the heater's inlet air damper adjusted to establish the heat output and burn rate desired.

## **ASHES - REMOVAL AND DISPOSAL**

Ashes should not be allowed to accumulate inside the heater to the point that they obstruct airflow through the burning wood. If ashes obstruct the airflow, poor burning of the wood is likely.

When removing ashes from the heater, wear noncombustible gloves to protect your hands from hot surfaces and use an ash shovel. **ASHES SHOULD BE PLACED IN A METAL CONTAINER WITH A TIGHT FITTING LID. THE CLOSED CONTAINER OF ASHES SHOULD BE PLACED ON A NONCOMBUSTIBLE FLOOR OR ON THE GROUND, WELL AWAY FROM ALL COMBUSTIBLE MATERIALS, PENDING FINAL DISPOSAL. IF THE ASHES ARE DISPOSED OF BY BURIAL IN SOIL OR OTHERWISE LOCALLY DISPERSED, THEY SHOULD BE RETAINED IN THE CLOSED CONTAINER UNTIL ALL CINDERS HAVE THOROUGHLY COOLED.**

Ashes should never be placed in a wooden, cardboard, or plastic container, nor in a paper or plastic bag, no matter how long the fire has been out. Coals have been known to stay hot for several days when embedded in ashes.

## SECTION 3

# CARE OF THE HEATER AND IT'S VENTING SYSTEM

## VENTING SYSTEM CARE

The venting system consists of the heater's chimney connector pipe and chimney itself. It is very important that the venting system be kept clean and in good repair.

### CREOSOTE - FORMATION AND NEED FOR REMOVAL

When wood is burned slowly, it produces tar and other organic vapors which combine with expelled moisture to form creosote. The creosote vapors condense in the relatively cool chimney flue of a slow burning fire. As a result, creosote residue accumulates on the flue lining. When ignited, this creosote makes an extremely hot fire.

The chimney connector and chimney should be inspected at least once every two months during the heating season to determine if a creosote buildup has occurred. If creosote has accumulated, it should be removed to reduce the risk of a chimney fire. Do not allow the creosote buildup to exceed 1/8-inch.

Initially, check the venting system more frequently until creosote accumulation rates are determined. Accumulation rates may change due to such factors as a new supply of wood with a different moisture content than the wood previously burned. Also, switching from one heating situation to another can cause the rate of accumulation to change because less creosote is produced when the heater is operated at a hotter burn rate than when the heater was operated at a lower burn rate. Become familiar with how fast creosote can accumulate under various operating conditions.

A chimney fire is usually indicated by a roaring noise within the chimney and/or a pinging noise within the chimney connector, and the emissions of sparks and ash from the top of the chimney.

If a chimney fire should occur, do the following:

1. Alert all people in the house. Either have them leave or be ready to leave.
2. Set the heater's inlet air control lever to the "LO" position.
3. Immediately close the fuel feed door if open.
4. Close all flue dampers
5. Call the fire department
6. As an added precaution, the roof of your home and other combustibles may be protected by wetting with an garden hose or buckets of water.

A chimney fire may cause structural damage to the chimney. After the chimney fire is over, thoroughly inspect the chimney connector and surrounding materials for damage and make any necessary repairs before using the heater again. Most fire departments make free chimney inspections and can provide assistance in locating chimney cleaning or repair services.

### CHIMNEY CONNECTOR PIPE - CORROSION INSPECTION

Chimney connector pipes do not last forever. Corrosion is particularly a problem if the inside of the pipe tends to get damp from condensation of flue gases or rain or snow getting into the chimney.

Chimney connector pipe replacement may be necessary more than once a season, but once every few years is more typical. Every time the chimney and chimney connector are checked for creosote buildup, the strength and integrity of the chimney connector pipes should also be checked.

### SPARK ARRESTERS AND CHIMNEY CAPS

Spark arresters and chimney caps can become clogged with creosote, leaves or other matter which could cause smoke and the dangerous carbon monoxide in smoke to spill back into your home. Spark arresters and chimney caps should be cleaned regularly to prevent them from becoming clogged.

**CLEANING OF THE VENTING SYSTEM SHOULD BE DONE ONLY BY A QUALIFIED PERSON OR A LICENSED CHIMNEY SWEEP**

**THE VENTING SYSTEM SHOULD ALWAYS BE INSPECTED AND CLEANED BEFORE EACH HEATING SEASON BY A QUALIFIED PERSON.**

---

## VENTING SYSTEM CARE

---

When cleaning is necessary, the outer surfaces of the heater may be wiped free of dust with a soft cloth. Mild soap suds applied with a soft cloth may also be used; wipe dry with a clean, dry, soft cloth after cleaning with soap suds.

Check heater components regularly and make adjustments or replacements as required to maintain integrity of the heater. Maintain a tight seal of the fuel feed door by paying particular attention to the gaskets, latching mechanism, and glass. The door should never be used with damaged or missing parts. Replace all damaged or missing parts. Do not replace any part with a different type; use only parts supplied by this heater's manufacturer. See figures 12 and 13 for part numbers and replacement illustrations.

When the fuel feed door is closed and latched, the latching mechanism should maintain a snug seal between the door gaskets and the door jamb to permit airtight operation of the heater. A snug seal is evident if an impression is made in the door gasket by the door jamb, without any gaps. If gaps are present in the door gasket or if the door is loose when closed and latched, the plate latch (see figure 13) may just need to be retightened, or the door gasket may be worn out or damaged. To replace the door gasket by figure 13:

1. Obtain correct door gasket and cement.
2. Remove the door from the heater by opening the door and lifting it up and off the heater. Place the door front-down on a sturdy surface.
3. Remove the old gasket from the door and scrape any residue from the gasket surface on the door. The gasket surface needs to be free of residue for best application of the new gasket.
4. Apply a bead of cement (about 3/16" in diameter) around the gasket surface on the door, in a zig-zag pattern. Do not spread the bead of cement.
5. Apply the gasket to the gasket surface. Keep the gasket width as wide as possible for best airtight sealing and to assure small misalignment are compensated for. As the gasket is applied at each corner of the door, push the gasket into the corner to achieve a full seal. Cut and remove any excess gasket once entire gasket surface is covered.
6. Put door back on heater. Close and latch door. Re-open the door and inspect the impression left by the door jamb in the door gasket. The jamb must be contacting the gasket entirely around the door for a good airtight seal. If the jamb is not contacting the gasket in one or more areas, reposition the gasket to assure contact. Once the gasket is properly aligned, close and latch the door.
7. Allow the cement to harden with the door closed and latched. Recheck the seal again before building the first fire.

The fuel feed door is equipped with heat resistant ceramic glass that will withstand temperatures well beyond the heater's operating range. Reasonable care, however, must be taken to prevent damaging the glass. Striking, slamming, or closing the door against the wood fuel could cause cracking or breakage of the glass. Cracked glass can break suddenly when heated. Do not use the heater with cracked or broken glass. If the glass must ever be replaced, replace it only with glass provided by the heater's manufacturer; see figure 13. To replace the glass as illustrated by figure 13:

1. Obtain correct glass. If the glass gasket is damaged, it must be replaced as well.
2. Remove nuts which secure the glass retainers to rear of fuel feed door. Then carefully remove the glass retainers, old glass, and glass gasket.
3. Position gasket snugly around entire perimeter of new glass.
4. Place the new gasketed glass against rear of fuel feed door (as shown by figure 13) and secure in place by reinstalling

---

## TROUBLESHOOTING

---

While the manufacturer has made every reasonable effort to ensure that this heater operates properly and satisfactorily, sometimes problems do arise. The following troubleshooting guide list several problems with there probable cause and remedy. Any adjustments and/or replacements must be made by a qualified person.

1. **PROBLEM:** Inadequate draft with symptoms such as difficulty in starting a fire in the heater, smoke spilling from the heater, or poor heat output.

**CAUSE / REMEDY:**

1. Chimney too short / Extend height of chimney.
2. Chimney diameter too large / Install 6-inch chimney or 6-inch chimney liner.
3. Chimney obstructed / Remove obstruction from chimney.
4. Bends in venting system / Increase height in chimney to overcome resistance.
5. Inlet air obstruction / Remove obstruction.

2. **PROBLEM:** Poor heat output.

**CAUSE / REMEDY:**

1. Wet or unseasoned wood is being burned / Burn natural wood which has been seasoned. See "WOOD FACTS" portion of this manual.
2. Inadequate draft / Remove obstruction.

3. **PROBLEM:** Heater overfiring with symptoms such as short burn time, or low burn rate can not be maintained, or heater and chimney connector glowing red.

**CAUSE / REMEDY**

1. Chimney too tall / install damper in chimney connector to restrict draft, or shorten chimney.
2. Fuel feed door not securely closed / Securely close fuel feed door.
3. Air leak around fuel feed door gasket or glass gasket / Stop leak.
4. Inlet air damper open too much / Reduce inlet air
5. Chimney fire / Close the heater's inlet air and the chimney connector damper if there is one and see the "CREOSOTE - FORMATION AND NEEDED FOR REMOVAL" portion of this manual.

4. **PROBLEM:** Short burn times.

**CAUSE / REMEDY:**

1. Softwood fuel being burned / change to harder wood. See "WOOD FACTS" portion of this manual
2. Small fuel load in heater / Increase fuel load.
3. Heater being overfired / See "Heater overfiring" causes and remedies above.

---

## WARRANTY CLAIM INFORMATION AND REPAIR PARTS

---

A heater warranty is included with this owner's manual. For warranty claims, follow the instructions provided by the warranty.

Order all repair parts from your heater dealer. Use the following Figures 12 and 13 for reference when ordering repair parts. To help assure prompt and accurate filling of repair parts orders, please supply the following information when placing a repair part order:

1. MODEL NUMBER OF HEATER
2. PART NAME
3. PART NUMBER (Not key number)
4. QUANTITY OF PARTS NEEDED

**FIGURE 12 -  
HEATER REPAIR PARTS DIAGRAM AND  
PARTS LIST**

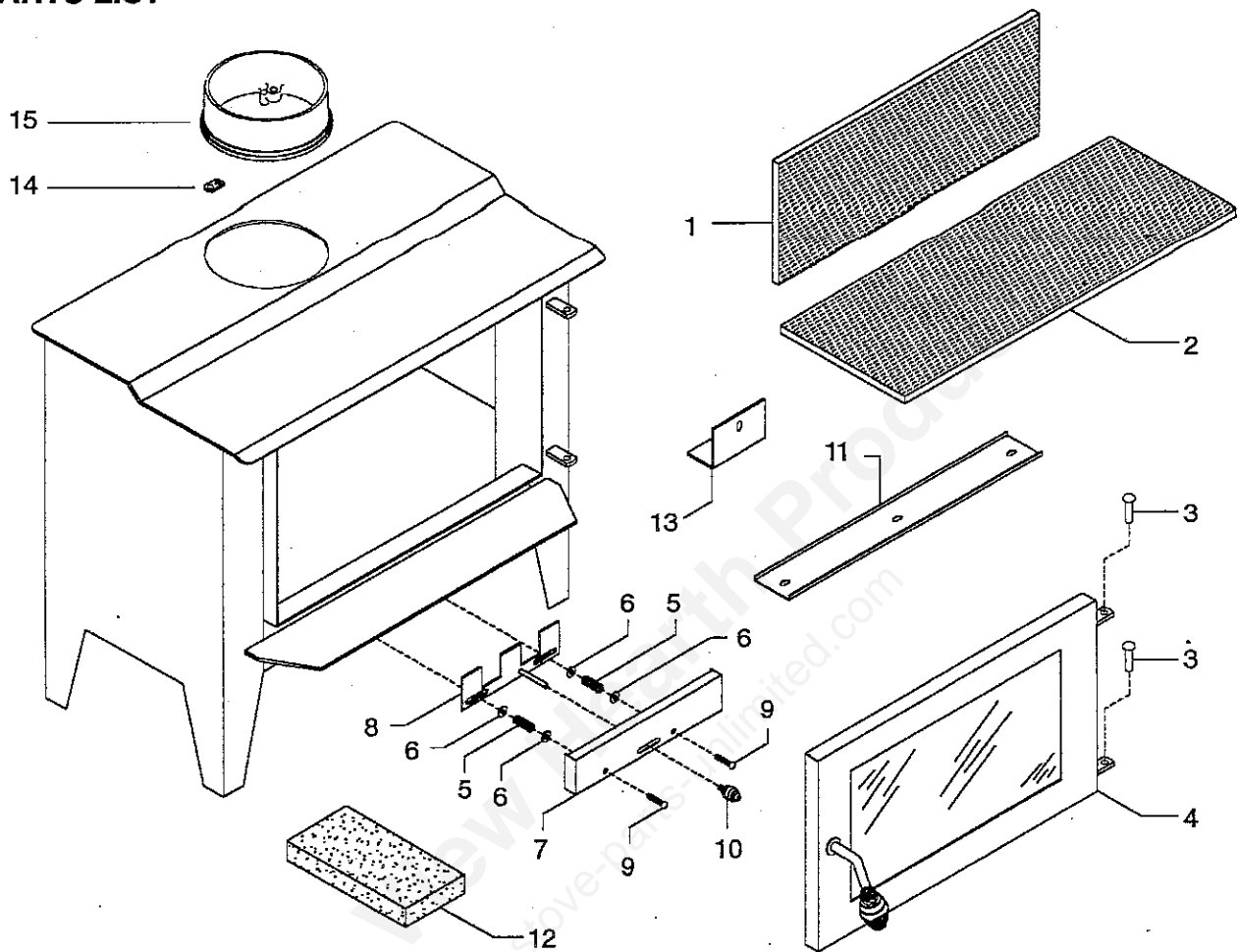

KEY NO.	DESCRIPTION	PART NO.	QTY.
1	AIRWASH INSULATION	89958	1
2	AIR TUBE INSULATION	89957	1
3	HINGE PIN	83443	2
4	FEED DOOR ASSEMBLY	69268	1
5	COIL SPRING	89955	2
6	FLAT WASHER	83136	4
7	INLET AIR COVER	24919	1
8	AIR SLIDE WELDMENT	69262	1
9	SCREW 1/4-20 x 1-1/4 TRUSS HEAD BOF	83499	2
10	SPRING HANDLE	89954	1
11	INSULATION RETAINER	24920	2
12	CERAMIC BRICK	89066	18
13	CENTER INSULATION RETAINER	24922	1
14	WELD TAB	83431	3
15	FLUE COLLAR	24212	1
N/S	5/16-18 x 1-1/2 HX HD BOLT	83432	3
N/S	1/4-20 KEP NUT	83250	7

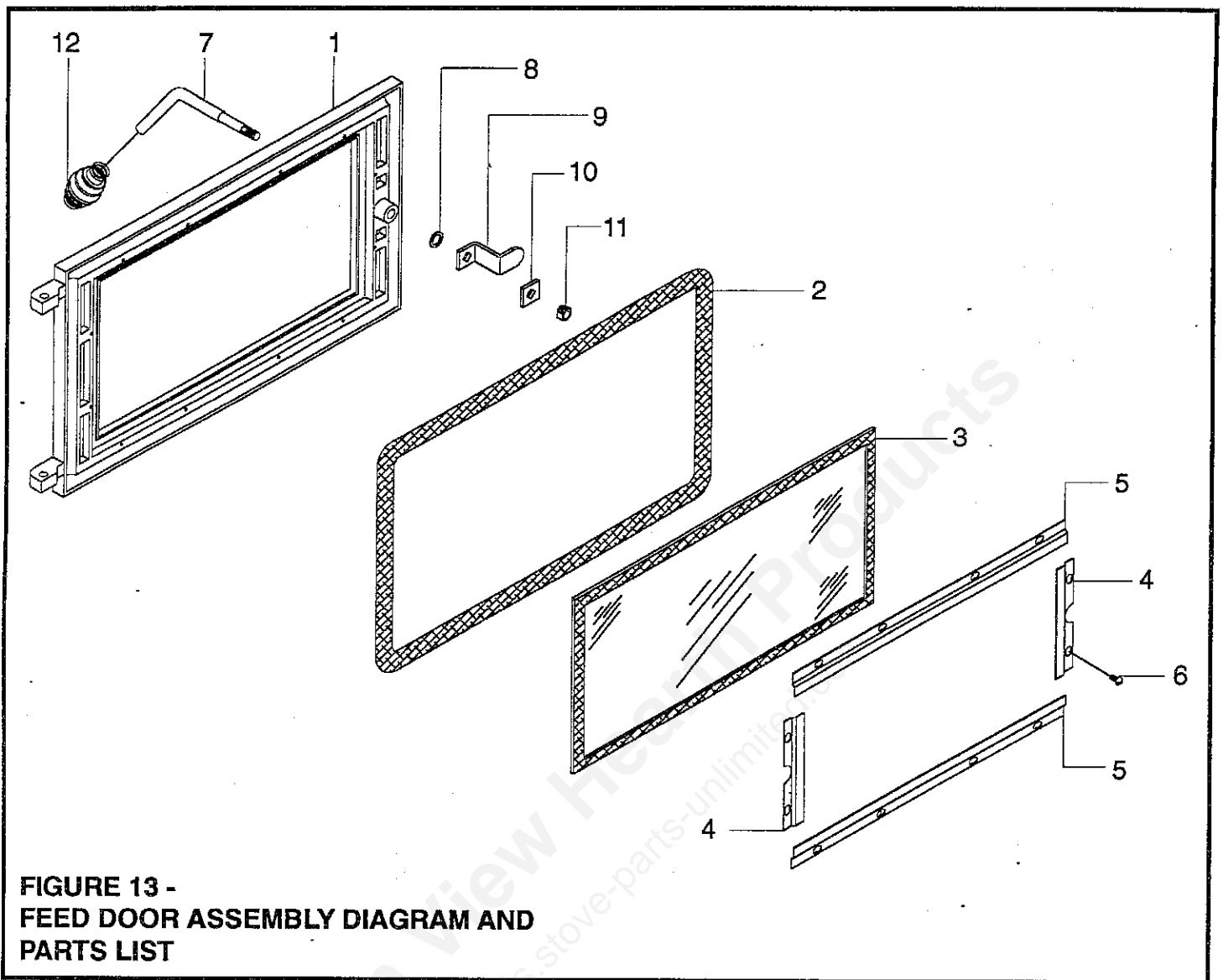

**FIGURE 13 -  
FEED DOOR ASSEMBLY DIAGRAM AND  
PARTS LIST**

KEY NO.	DESCRIPTION	PART NO.	QTY.
1	CAST IRON FEED DOOR	24997C	1
2	1/2 ROUND ROPE GASKET	88057	5.25 ft
3	GLASS AND ROPE ASSEMBLY	69269	1
4	SIDE GLASS RETAINER	24916	2
5	TOP & BOTTOM GLASS RETAINER	24918	2
6	10-24 x 1/4" MACHINE SCREW	83362	12
7	HANDLE	89577	1
8	WASHER, 1/2 I.D.; 3/4 O.D.	24934	2
9	STEP LATCH	25008	1
10	LATCH SPACER	21467	1
11	3/8-18NC LOCK NUT	83178	1
12	SPRING HANDLE	89574	1

# HOW TO ORDER REPAIR PARTS

THIS MANUAL WILL HELP YOU OBTAIN EFFICIENT, DEPENDABLE SERVICE FROM THE HEATER, AND ENABLE YOU TO ORDER REPAIR PARTS CORRECTLY.

KEEP IN A SAFE PLACE FOR FUTURE REFERENCE.

WHEN WRITING, ALWAYS GIVE THE FULL MODEL NUMBER WHICH IS ON THE NAME-PLATE ATTACHED TO THE BACK OF THE HEATER.

WHEN ORDERING REPAIR PARTS, ALWAYS GIVE THE FOLLOWING INFORMATION AS SHOWN IN THIS LIST:

1. The PART NUMBER
2. The PART DESCRIPTION
3. The MODEL NUMBER: NCA1
4. The SERIAL NUMBER: \_\_\_\_\_

UNITED STATES STOVE COMPANY  
227 Industrial Park Road  
P.O. Box 151  
South Pittsburg, TN 37380  
(423) 837-2100