

owners manual
Franklin Fireplace

MODEL NUMBER
261-ST

MODEL NUMBER
301-ST

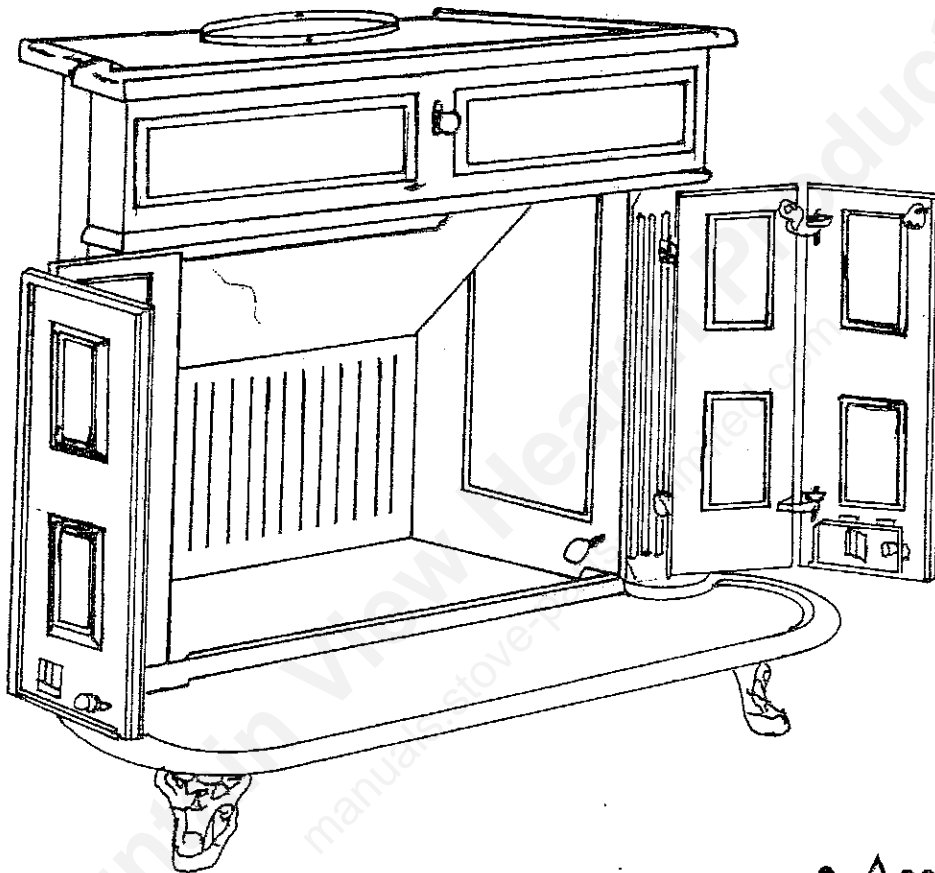

CAUTION:
Read All Instructions
Carefully Before Start-
ing The Installation.

- Assembly
- Installation
- Operation
- Repair Parts

Save This Manual For
Future Reference.

**DO NOT USE THIS FIREPLACE
IN A MOBILE HOME OR TRAILER**



UNITED STATES STOVE COMPANY

South Pittsburg, TN. 37380
Home heating equipment made in America since 1869

FORM 85117 6/78

rules for safe installation and operation

1. Read these rules and the instructions carefully. Failure to follow them could cause a malfunction of the fireplace. This could result in death, serious bodily injury, and/or property damage.
2. Check your local codes. The installation must comply with their rulings.
3. Do not install this fireplace in a mobile home or trailer.
4. Always connect this fireplace to a chimney and vent to the outside. Never vent to another room or inside a building.
5. Make sure the chimney is high enough to give a good draft. At least once each year, inspect the chimney and pipe to be sure it is clean inside. A build-up of soot will affect the draft and cause smoking. A chimney fire cannot happen in a clean chimney.
6. Always open damper before lighting fire.
7. Keep the ashpit section free of excess ashes. Failure to do so will cause grate warpage and burn out.
8. To hold a fire for a long period, place logs on fire and close front doors tight. Leave the bottom draft slides closed. Ashes may also be heaped on top of the fire for better holding. The damper should be opened. Where there is poor draft, it may be necessary to open door draft slides.
9. Do not burn more than one imitation log at a time. Follow the directions on these logs closely.
10. When the fire is out, always close the front doors, flue damper, and draft slides. A warm flue will remove heat from the living space. **THIS IS ESPECIALLY IMPORTANT WHERE THE FRANKLIN FIREPLACE IS USED IN HOMES WHICH HAVE CENTRAL HEATING SYSTEMS.**
11. To prevent injury, do not allow anyone who is unfamiliar with the operating instructions to use fireplace.
12. Do not store or use flammable liquids, especially gasoline, in the vicinity of the room heater.
13. Ashes should be placed in a metal container with a tight fitting lid. The closed container of ashes should be placed on a non-combustible floor or on the ground, well away from all combustible materials, pending final disposal. If the ashes are disposed of by burial in soil or otherwise locally dispersed, they should be retained in the closed container until all cinders have thoroughly cooled.

assembly and installation

Uncrate the Franklin Fireplace. Remove the parts inside it. Tilt the Franklin toward the back and slide the front legs into the locking lugs. Then tilt the Franklin toward the front. Install the leveling screw (Key No. 22) in rear leg. Install the rear leg to the firebox bottom using the nuts and bolts supplied. Be sure to install the leg so that the leveling screw is towards the back of the firebox.

SELECTING A LOCATION

For a unique and very attractive installation, your Franklin may be placed in an existing fireplace opening (Fig. 1). This can be done either with or without the legs. Check the dimensions of your fireplace against the dimensions of your Franklin. If the opening is too large, you can fill it in with matching brick. If your fireplace has a good draft, it will have a good draft with the Franklin in place. Simply slide the Franklin into the opening and seal the opening.

FIG. 1 PLACEMENT IN EXISTING FIREPLACE
(Not For Use With Heat Shield Kits)
(Not Accepted By I.C.B.O.)

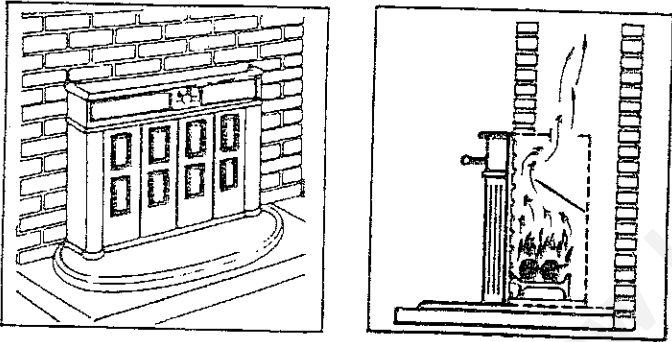

As a location is selected keep the following in mind:

1. The flue connection should be as short as possible. The fireplace should have its own chimney. No other appliance should be connected to the chimney. If there is no chimney near where you wish to place the Franklin, you can use a Type "A" Prefabricated All-Fuel Chimney.
2. The floor should be level and fireproof. A solid concrete or brick floor is acceptable. If your floor is combustible, it should be covered with brick or patio stone at least 1-1/4" thick, set on a piece of metal or asbestos millboard. The brick or stone must extend 21" to the rear of the Franklin, 18" to the front and 12" to either side (Fig. 4). The Heat Shield Kit shown in Figure 4 should be used when the Franklin is placed on a combustible floor.

FIG. 2 REQUIRED CLEARANCES
(TOP VIEW)

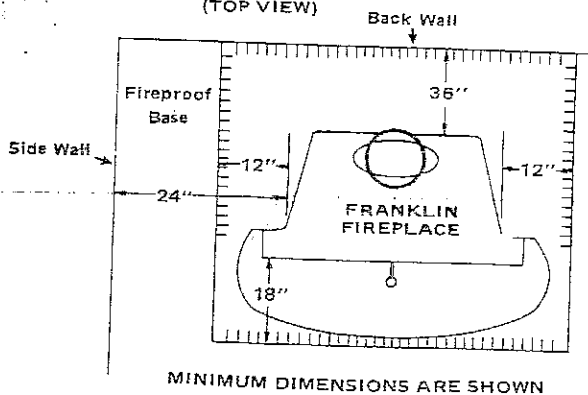
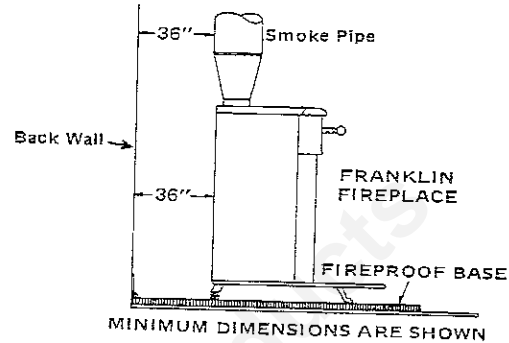

FIG. 3 REQUIRED CLEARANCES
(SIDE VIEW)



The 36" clearance to the backwall can be reduced to 18" if you use a special Heat Shield Kit (Fig. 4). Order the Kit Stock No. shown for your model Franklin.

KIT STOCK NO.	FRANKLIN FIREPLACE MODEL NO.	FIREBOX OPENING
HS-26A	261-ST	25 3/4"
HS-30A	301-ST	30"

FIG. 4 REQUIRED CLEARANCES
WITH HEAT SHIELD KIT
INSTALLED

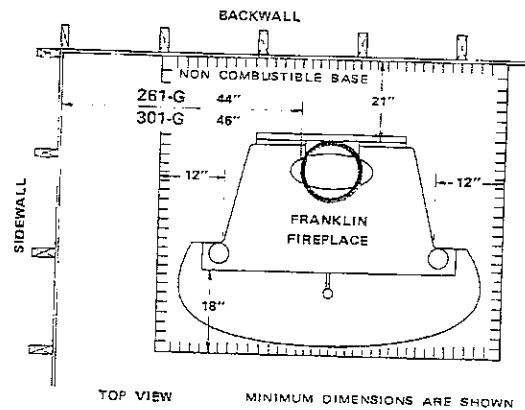

If you have a solid brick or stone wall behind your Franklin, you can place the Franklin as close as you wish to the wall. If the wall is only faced with brick or stone, check your local code for the correct clearances.

installation

Connect your Franklin to a masonry chimney having at least an 8" x 8" (inside dimension) flue liner. If a chimney is not near the Franklin location, you can install a Type "A" ALL FUEL CHIMNEY (Figs. 6 & 7). This chimney is especially made for fireplaces. It has a stainless steel liner 8" in diameter. It is the same size as your Franklin smoke pipe.

Chimney height must be sufficient to create a good draft and minimize smoking. As a general guide, the chimney should extend 15 feet above the top of a 26" Franklin and 18 feet above the top of a 30" Franklin.

WARNING

Never connect a wood burning fireplace to an aluminum Type B gas vent. This is not safe and is prohibited by the National Fire Protection Association Code. If connecting to a prefabricated chimney, be sure it is a Type "A" ALL-FUEL CHIMNEY having a stainless steel liner. The liner must be at least 8" inside diameter. The Type "A" ALL-FUEL CHIMNEY must be used even if gas logs are used.

Look at Fig. 5. The 8" diameter smoke pipe and fittings you will need to connect to a masonry chimney or an ALL-FUEL CHIMNEY on the outside wall are shown.

If your ALL-FUEL CHIMNEY starts at the ceiling (Fig. 7), you will need only enough pipe to reach the ceiling, a finishing collar, and a connector adapter.

Be sure that you have at least 18" of clearance between the horizontal piping and the ceiling. (Fig. 6)

CONDENSATION NOTE

In cold climates, warm, moist house air escaping through the fireplace damper can cause condensation to form on the cold, inside walls of a metal chimney. This can cause water to drip into the fireplace. This occurs when the fireplace is not in use.

Metal prefabricated chimney performs well if properly installed. The following precautions must be observed.

1. Make chimney sections absolutely vertical. Do not allow any pipe or chimney sections to be cocked.
2. Your Franklin damper must fully close when the handle is pushed all the way in and the fireplace is not in use to reduce to a minimum the amount of warm air that escapes up the chimney.

If the damper is not seating tightly, loosen the mounting screw for the Metal Stop Bracket (Key No. 10, page 8), and slide the bracket forward. Tighten the screw and check to assure that the damper is fully closed when the damper knob is pushed in and the Metal Stop Bracket is engaged.

3. The installation shown in Fig. 6 will avoid the problem of condensation. The elbow to the outside and the insulated tee offset the chimney. Any condensation stays outside the house.

FIG 5

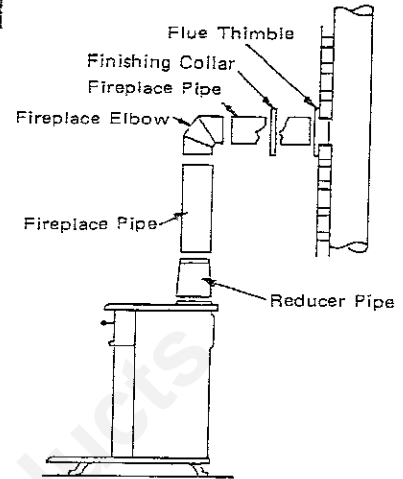

FIG 6

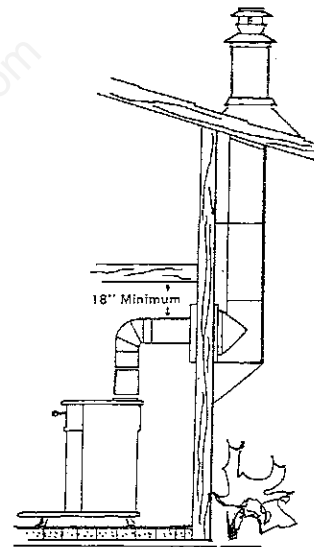
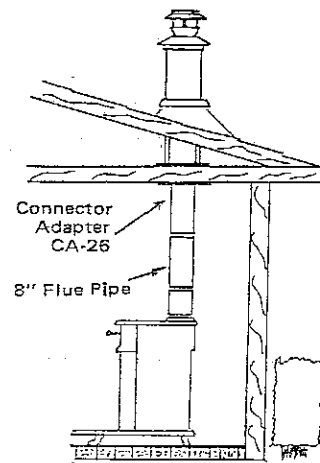

FIG 7



operation

1. Open the damper by pulling the damper knob outward.
2. Place paper and/or kindling in the grate basket.
3. You can get a better chimney draft with a warm flue. Place a roll of paper in the opening as near as you can to the flue opening inside the fireplace, and light it to preheat the chimney.
4. Light the fuel in the grate. Add fuel, carefully at first to avoid smothering the fire. When the fire is going well, fuel may be added in the amount desired.
5. You can control the rate of burning by moving the damper knob or closing the front doors.
6. Use a firescreen to prevent sparks from entering the room.

NOTE: Operate your Franklin Fireplace with the doors closed whenever possible. This will use less wood, give more heat in the room and will prevent smoke from entering the room when the chimney draft is not adequate.

IF FIREPLACE SMOKES, CHECK THE FOLLOWING

A. Incorrect Chimney

1. Chimney should extend at least 3 feet above the highest point where it passes through the roof. It should also be at least 2 feet higher than any portion of the building within 10 feet.
2. The fireplace chimney should have no other appliances attached to it. All unused openings and the clean-out door at the chimney base should be sealed.
3. The draft or "drawing" of the fireplace is fully dependent on the chimney. A chimney must be high enough and warm enough to provide draft. Adding chimney height should improve draft.
4. Pipe inserted too far through a thimble into chimney opening.
5. Pipe obstructed with soot. Regular cleaning of the chimney is recommended for maximum efficiency and to reduce the danger of chimney fires.

B. Helpful Hints

1. Starting a fire in a cold room tends to produce smoke while the chimney is cold. When the chimney warms up, the smoking should stop.

2. Fires should be built to the rear of the unit.

3. When adding fuel, make sure that the damper is open.

4. The use of the grate basket promotes a better fire and minimizes smoke.

C. Air Supply

1. A tightly constructed home with well fitting windows, weatherstripping and store sash has little air infiltration. No air will move up a chimney unless air enters the room containing the fireplace. A tight house should have a fresh air intake at least 25 square inches in area. If there is no air intake in the room with the fireplace, air must be provided through open windows and doors when the fireplace is operating.

2. Ventilating fans move large volumes of air. If normal air infiltration is not great enough to satisfy the needs of a fireplace AND ventilating fan, air will be drawn down the chimney creating a smoking condition. The fresh air intake must provide enough for both.

3. A furnace or boiler also requires an air supply for proper burning. This air must be provided in addition to the fireplace and other needs.

repair parts

FRANKLIN FIREPLACE

MODEL NOS. 261-ST AND 301-ST

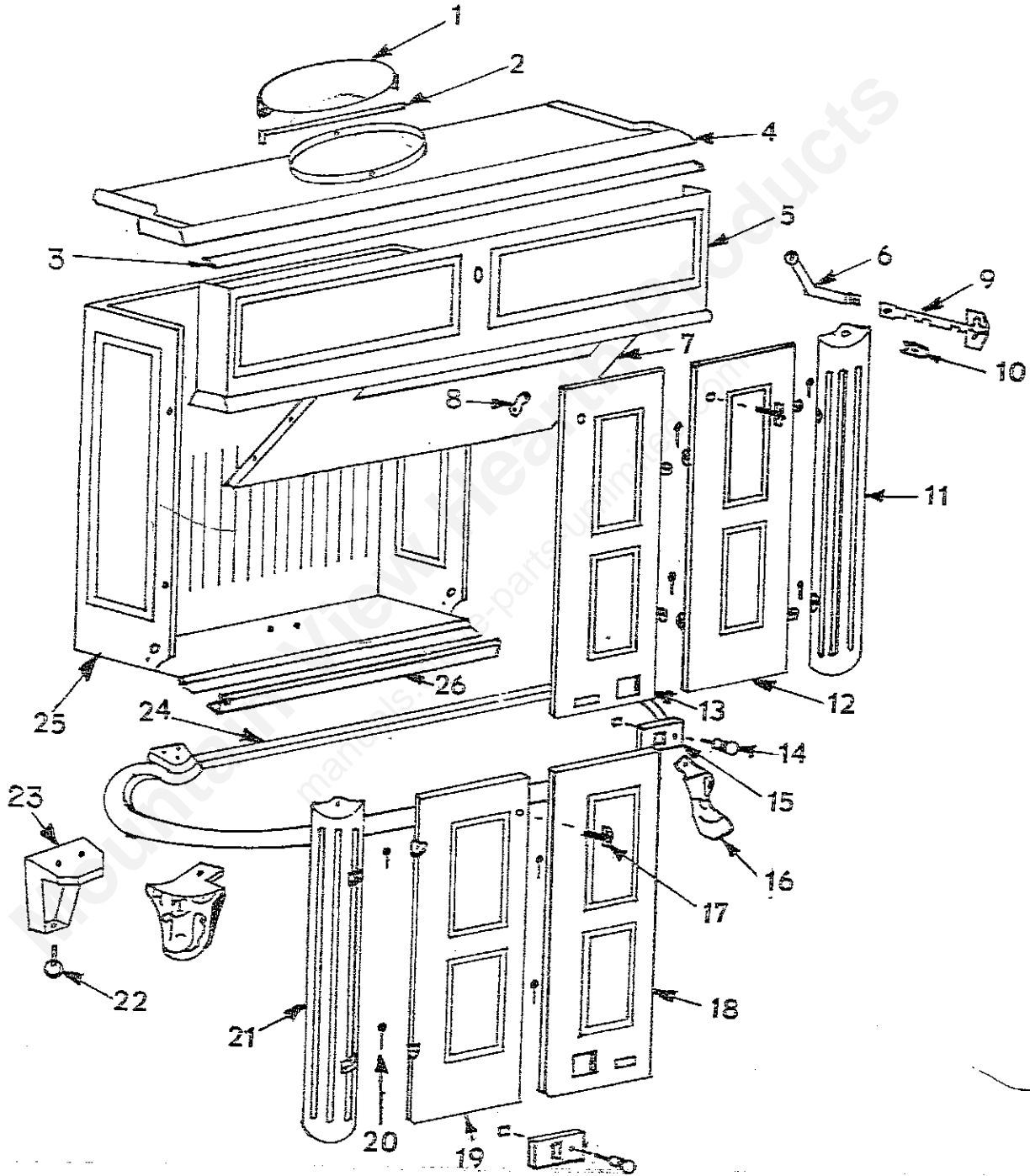

repair parts

FRANKLIN FIREPLACE
MODEL NUMBERS 261-ST AND 301-ST

KEY NO.	MODEL NO.		DESCRIPTION
	261 ST	301 ST	
	PART NO.	PART NO.	
1	40011	40011	Damper
2	21192	21192	Damper Pin
3	88045	88044	Top Seal Strip
4	67409	67410	Top Main
5	40024	40030	Upper Front
6	40013	40013	Arm, Damper Control
7	21198	21184	Baffle
8	21187	21187	Catch, Door (3 required)
9	40025	40025	Knob, Damper Control
10	21183	21183	Bracket, Damper Control
11	40016	40016	Column, Right Side
12	40028	40033	Door, Right Outer
13	40029	40034	Door, Right Center
14	40022	40022	Knob, Draft Slide (2 required)
15	21188	21188	Draft Slide (2 required)
16	40023	40023	Leg (2 required)
17	40021	40021	Door Handle (3 required)
18	40027	40032	Door, Left Center
19	40026	40031	Door, Left Outer
20	83114	83114	Door, Pin (8 required)
21	40015	40015	Column, Left Side
22	83113	83113	Leg, Leveler
23	21189	21189	Adjustable Leg
24	67241	67235	Hearth
25	67239	67234	Back, Sides, & Bottom
26	21199	21186	Door Stop
*	85117	85117	Owners Manual

NOTE

All bolts and nuts are standard hardware items and may be purchased locally.

Accessories

FRANKLIN FIREPLACE
 NUMBERS 261-ST AND 301-ST

THE FOLLOWING ITEMS ARE NOT PART OF Y
 BUT MAY BE ORDERED SEI

*Manufactured
 Franklin*

260 - 300

*315 785-0395
 Pot*

BOSTON BEAN POT WITH CRANE HOOK — NO. BP-26

KEY NO.	PART NO.	NAME OF PART
	40026 40026	CRANE HOOK CRANE HOOK
1	67198	Pot and Hook Complete
2	40010	Cover
3	67197	Pot Rack Assembly
4	21132	Bracket



CAST IRON BARBECUE GRID — NO. GR-26

KEY NO.	PART NO.	NAME OF PART
	40004 GR-26	Grid, Complete
1	40004	Grid, Complete
2	40002	Support, Grill
3	40003	Arm, Grill
4	40001	Leg, Grill Adjusting
5	21132	Grill Bracket

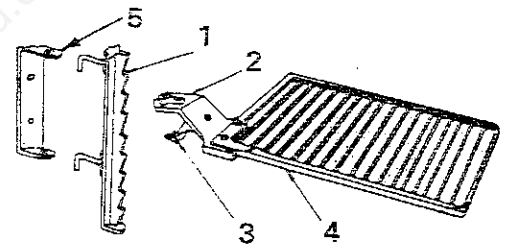

HEAT SHIELD KIT

KEY NO.	QTY.	PART NUMBERS FOR KIT NUMBERS		DESCRIPTION
		261-ST	301-ST	
1	1	HS-26A	HS-30A	Kit Complete
2	5	21558	21579	Inner Rear Liner
3	1	18760	18760	Mounting Bracket — Bottom
4	1	67505	67506	Inner Bottom Shield Asm.
5	1	19590	19450	Bottom Shield
6	1	67499	67501	Rear Heat Shield Asm.
7	1	21590	21590	Mounting Bracket—Back Shield
8	1	19550	19550	Reducer Shield
*	14	21605	21605	Heat Shield Handle
*	14	83165	83165	Metal Screw No. 10 x 1/2 Slotted Hex Head
*	5	83001	83001	Nut — 1/4 - 20
*	1	85226	85226	Owners Manual

*HS26A Heat Shield
 Ass'y*

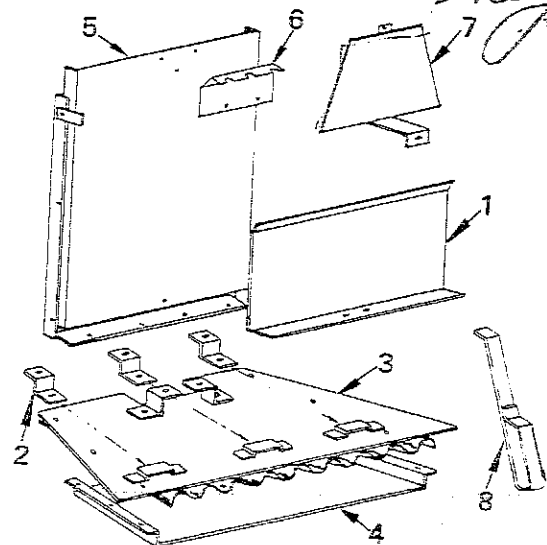

* Not Illustrated

accessories

FRANKLIN FIREPLACE
MODEL NUMBERS 261-ST AND 301-ST

THE FOLLOWING ITEMS ARE NOT PART OF YOUR FRANKLIN FIREPLACE,
BUT MAY BE ORDERED SEPARATELY.

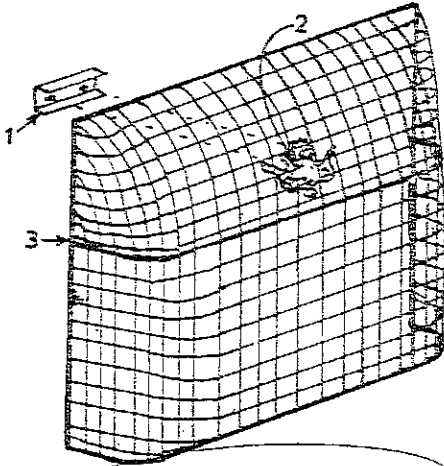

PARLOR SCREEN

KEY NO.	MODEL NO.		DESCRIPTION
	261 ST	301 ST	
1	BS-26 11450	BS-30 11450	Screen Complete
2	89079	89079	Handle Bracket
3	67199	67201	Handle, Ornamental Basket Screen

CAST IRON GRATE BASKET

NO Castes Available

KEY NO.	MODEL NO.		DESCRIPTION
	261 ST	301 ST	
1	G-26 40005	G-30 40007	Grate Basket Complete
2	40006	40006	Basket Leg (4 Req.)

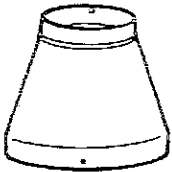
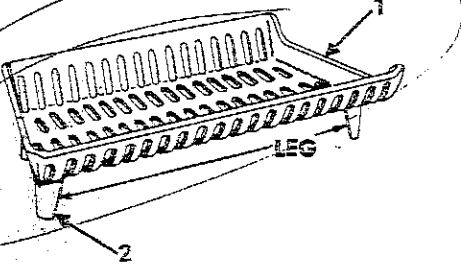

8" REDUCER R-26

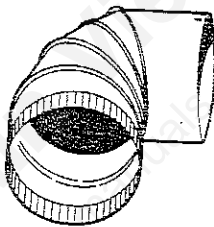

8" ELBOW E-26

Pipe and accessories are finished in mat black, heat resistant silicone paint to complement the Franklin. Made of heavy weight 24 gauge steel for long life.

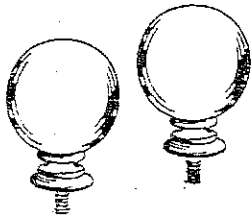

DECORATIVE BRASS KNOBS

BK-26

Set of two (2) easily installed on Franklin top.



8" COLLAR C-26

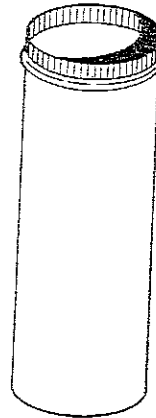

8" x 2' PIPE P-26

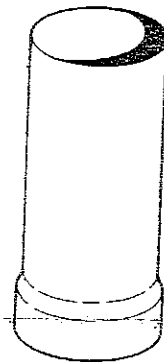

CONNECTOR ADAPTOR CA-26

owners manual

HOW TO ORDER REPAIR PARTS

THIS MANUAL WILL HELP YOU TO OBTAIN EFFICIENT, DEPENDABLE SERVICE FROM THE HEATER, AND ENABLE YOU TO ORDER REPAIR PARTS CORRECTLY.

KEEP IN A SAFE PLACE FOR FUTURE REFERENCE.

WHEN WRITING, ALWAYS GIVE THE FULL MODEL NUMBER WHICH IS ON THE NAMEPLATE ATTACHED TO THE BACK OF THE HEATER.

WHEN ORDERING REPAIR PARTS, ALWAYS GIVE THE FOLLOWING INFORMATION AS SHOWN IN THIS LIST:

1. The PART NUMBER
2. The PART DESCRIPTION
3. The MODEL NUMBER