

# UNITED STATES STOVE COMPANY

## INSTRUCTIONS & OPERATIONS MANUAL

### ACORN 1851B

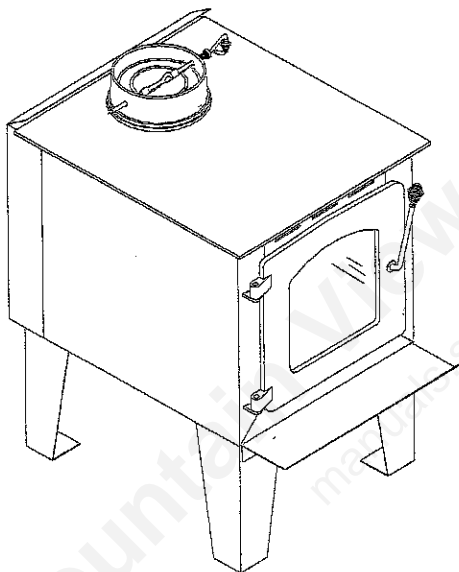

US ENVIRONMENTAL PROTECTION  
AGENCY 28A CERTIFIED  
WOODSTOVES

Verified and tested following  
UL 1482 Standards by:



*"Keeping America Warm Since 1869"*

**UNITED STATES STOVE COMPANY**  
227 Industrial Park Road  
Tel : ( 423 ) 837-2100  
Fax : ( 423 ) 837-2109  
[www.usstove.com](http://www.usstove.com)

**READ AND KEEP THIS MANUAL FOR REFERENCE**

# UNITED STATES STOVE COMPANY

## INSTRUCTIONS & OPERATIONS MANUAL

### KING 1851

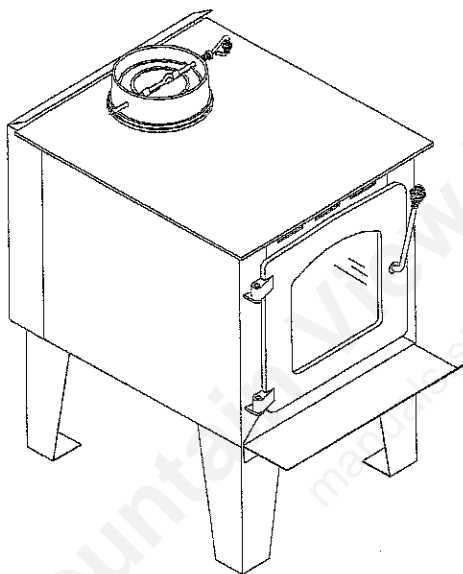

US ENVIRONMENTAL PROTECTION  
AGENCY 28A CERTIFIED  
WOODSTOVES

Verified and tested following  
UL 1482 Standards by:



*"Keeping America Warm Since 1869"*

**UNITED STATES STOVE COMPANY**  
227 Industrial Park Road  
Tel : ( 423 ) 837-2100  
Fax : ( 423 ) 837-2109  
[www.usstove.com](http://www.usstove.com)

**READ AND KEEP THIS MANUAL FOR REFERENCE**

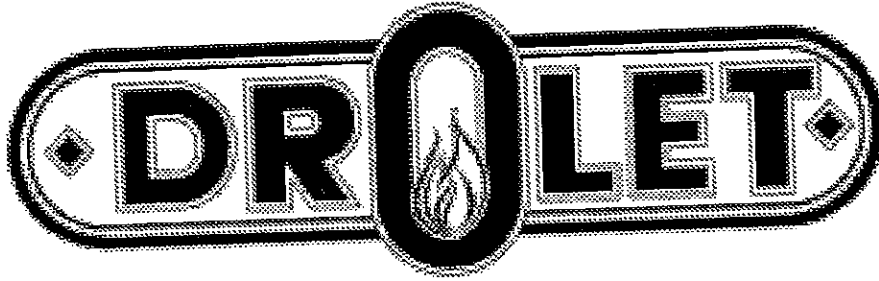

# INSTRUCTIONS & OPERATIONS MANUAL DROLET EE1200 WOODSTOVES:

## ML, RC, LITTLE SAWMAN, ACORN AND KING

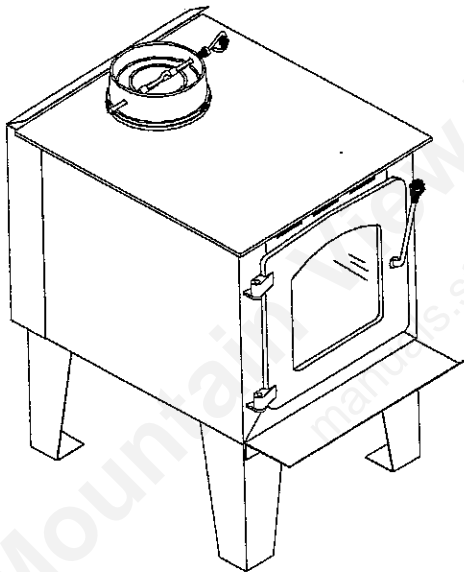

US ENVIRONMENTAL PROTECTION  
AGENCY 28A CERTIFIED  
WOODSTOVES

Verified and tested following  
UL 1482 Standards by:



Manufactured by : **STOVE BUILDER INTERNATIONAL INC.**  
1700, Léon-Harmel, Québec (Québec) G1N 4R9  
Tel : ( 418 ) 527-3060  
Fax : ( 418 ) 527-4311  
[www.drolet.ca](http://www.drolet.ca)

**READ AND KEEP THIS MANUAL FOR REFERENCE**

# TABLE OF CONTENTS

INTRODUCTION .....	2
ASSEMBLY.....	3
INSTALLATION .....	5
POSITIONING THE STOVE .....	5
CLEARANCES FROM COMBUSTIBLES.....	6
CHIMNEY.....	7
CHIMNEY CONNECTOR (STOVE PIPE) .....	8
TYPICAL INSTALLATIONS .....	9
WOODSTOVE UTILISATION.....	13
AVERAGE ENERGY YIELD OF ONE AIR DRIED CORD OF CUT WOOD .....	13
TESTING YOUR WOOD.....	14
THE FIRST FIRES .....	14
IGNITION .....	14
ASH DISPOSAL.....	15
AIR CIRCULATION SYSTEM.....	16
MAINTENANCE.....	16
GLASS .....	16
GASKETING .....	16
PAINT.....	17
FREQUENTLY ASKED QUESTIONS.....	18
WHAT DO THE WORDS "DRAFT" AND "NEGATIVE PRESSURE" MEAN? .....	18
CAN I MODIFY MY STOVE TO INSTALL A GLASS DOOR? .....	25
WHEN DO I NEED TO REPLACE THE FIREBRICKS? .....	25
LIMITED 3 YEARS WARRANTY.....	26

# INTRODUCTION

STOVE BUILDER INTERNATIONAL INC., one of the most important wood stove and fireplace manufacturers in Canada, congratulates you on your purchase and wishes to help you get maximum satisfaction from your wood stove. In the pages that follow, we will give you advice on wood heating and controlled combustion as well as technical specifications regarding installation, operation and maintenance of the model you have chosen.

The instructions pertaining to the installation of your wood stove comply with UL-1482 standards.

**Read this entire manual before you install and use your new stove. If this stove is not properly installed, a house fire may result. To reduce the risk of fire, follow the installation instructions. Failure to follow instructions may result in property damage, bodily injury, or even death.**

**Consult your municipal building department or fire officials about restrictions and installations requirements in your area and the need to obtain a permit.**

**Make sure you keep this instruction manual. It will always be helpful. We also suggest that you consult our web site at [www.drolet.ca](http://www.drolet.ca) . It will provide you with a full range of information, such as how to order replacement parts.**

## **CAUTIONS:**

- HOT WHILE IN OPERATION. KEEP CHILDREN, CLOTHING AND FURNITURE AWAY. CONTACT MAY CAUSE SKIN BURNS.
- DO NOT USE CHEMICALS OR FLUIDS TO IGNITE THE FIRE.
- DO NOT LEAVE THE STOVE UNATTENDED WHEN THE DOOR IS SLIGHTLY OPENED.
- DO NOT BURN WASTES, FLAMMABLE FLUID SUCH AS GASOLINE, NAPHTHA OR MOTOR OIL.
- DO NOT CONNECT TO ANY AIR DISTRIBUTION DUCT OR SYSTEM.
- ALWAYS CLOSE THE DOOR AFTER THE IGNITION.

# ASSEMBLY

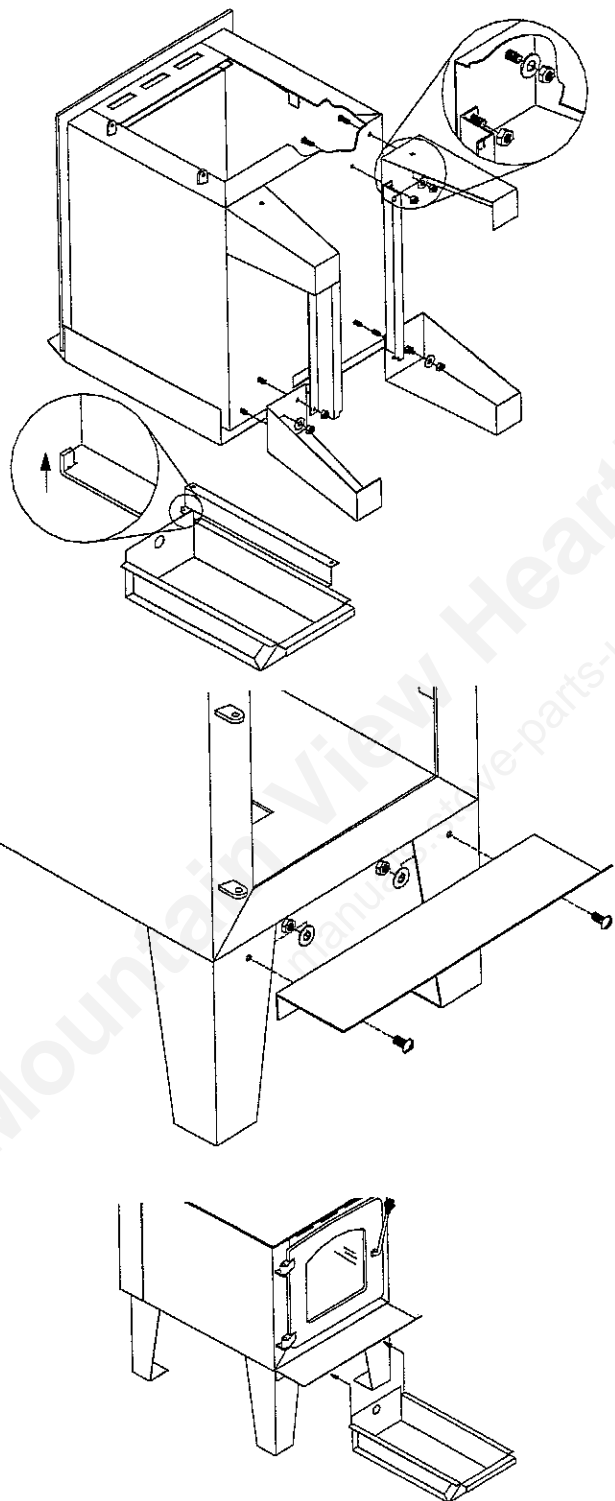

## Legs and ash pan rail intallation (some models only):

1. Position the stove on it's back;
2. Screw the legs and rails in place with 8 screws, 8 bolts, and 4 washers;
3. Fold up the ash pan stoppers on the rails.

## Ash lip Installation:

1. Screw in place with 2 bolts, 2 screws, and 2 washers.

## Ash pan installation:

1. Slide the ash pan on the two rails under the stove.

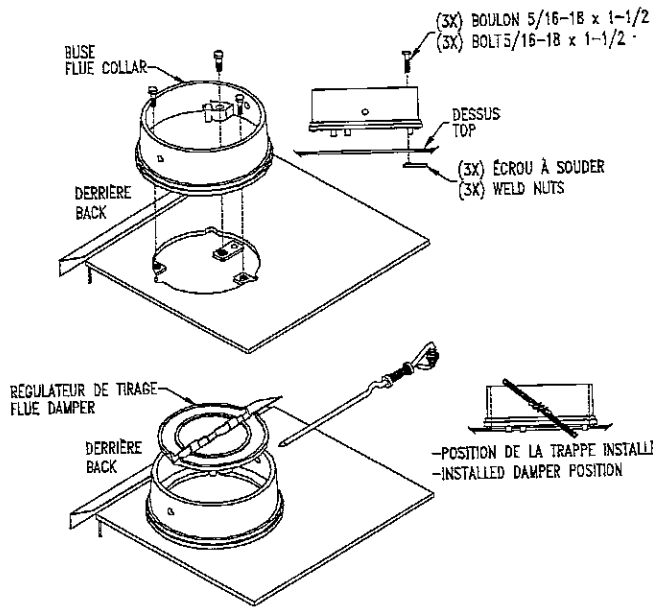

### Cast iron flue collar installation:

1. Peel off the tape from the back of the gasket and attach the gasket to the rope groove at the back of the flue collar;
2. Mount flue collar on top of the stove. Make sure that the damper holes on each side of the flue collar are parallel to the back of the stove;
3. Fix the flue collar with the hardware supplied;
4. Install the flue damper inside the flue collar as illustrated.

### Back air intake, ash dump cap, and firebricks installation:

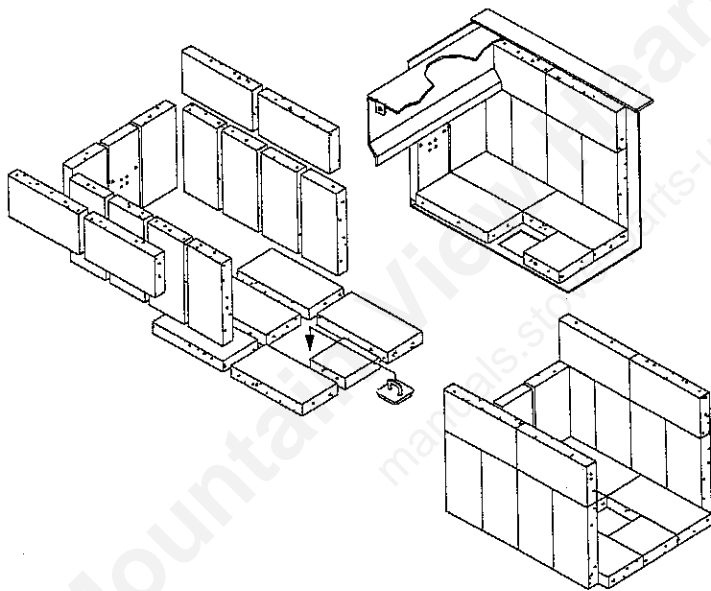

1. Slide the back air intake between the bracket welded inside the stove;
2. Install the bottom firebricks first, then the side ones;
3. Install the back firebricks;
4. Insert the ash dump cap on the bottom hole.

# INSTALLATION

## **SAFETY NOTICE**

- IF THIS STOVE IS NOT PROPERLY INSTALLED, A HOUSE FIRE MAY RESULT. TO REDUCE THE RISK OF FIRE, FOLLOW THE INSTALLATION INSTRUCTIONS. FAILURE TO FOLLOW INSTRUCTIONS MAY RESULT IN PROPERTY DAMAGE, BODILY INJURY, OR EVEN DEATH.
- CONSULT YOUR MUNICIPAL BUILDING DEPARTMENT OR FIRE OFFICIALS ABOUT RESTRICTIONS AND INSTALLATIONS REQUIREMENTS IN YOUR AREA.
- USE SMOKE DETECTORS IN THE ROOM WHERE YOUR STOVE IS INSTALLED.
- KEEP FURNITURE AND DRAPES WELL AWAY FROM THE STOVE.
- NEVER USE GASOLINE, GASOLINE-TYPE LANTERN FUEL, KEROSENE, CHARCOAL LIGHTER FLUID, OR SIMILAR LIQUIDS TO START OR "FRESHEN UP" A FIRE. KEEP ALL SUCH LIQUIDS WELL AWAY FROM THE STOVE.
- IN THE EVENT OF A CHIMNEY FIRE, CALL THE FIRE DEPARTMENT.
- DO NOT CONNECT TO ANY AIR DISTRIBUTION DUCT OR SYSTEM.
- A SOURCE OF FRESH AIR INTO THE ROOM OR SPACE HEATED SHALL BE PROVIDED WHEN REQUIRED.

## **POSITIONING THE STOVE**

It is very important to position the wood stove as close as possible to the chimney, and in an area that will favour the most efficient heat distribution possible throughout the house. The stove must therefore be installed in the room where the most time is spent, and in the most spacious room possible. Recall that wood stoves produce radiating heat, the heat we feel when we are close to a wood stove. A wood stove also functions by convection, that is through the displacement of hot air accelerated upwards and its replacement with cooler air. If necessary, the hot air distribution from the stove may be facilitated by a blower or the installation of floor or wall grids.

**The wood stove must not be hooked up to a hot air distribution system since an excessive accumulation of heat may occur.**

**A wood stove must never be installed in a hallway or near a staircase, since it may block the way in case of fire or fall to respect required clearances.**

## CLEARANCES FROM COMBUSTIBLES

It is of outmost importance that the clearances to combustible materials be scrupulously respected upon installation of the stove you have selected. Refer to the tables below :

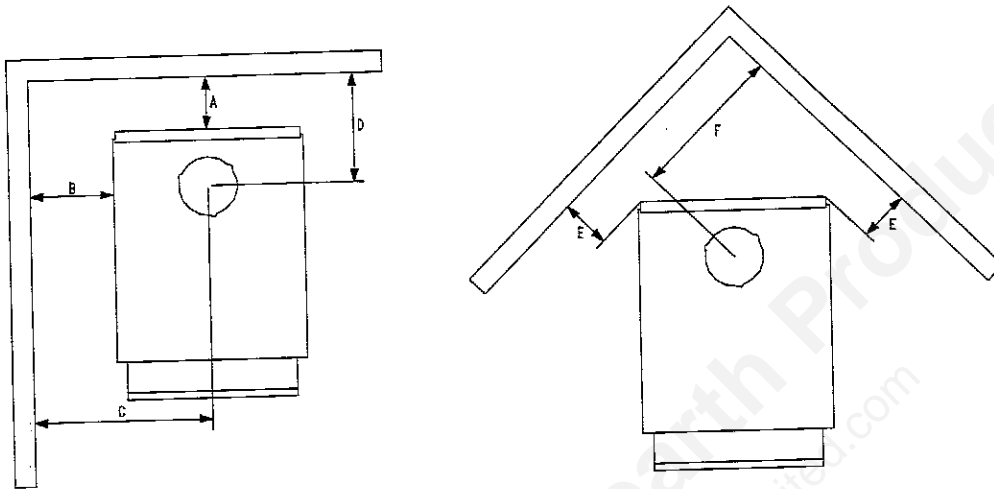

Single pipe / Double pipe					
A	B	C	D	E	F
29"	30"	39"	34-3/4"	22"	32"

- Floor to ceiling height must be at least 7' (84") in all cases.
- The clearance between the flue pipe and a wall are valid only for vertical walls and for vertical flue pipe.
- The flue pipe must not go through roof trussing, an attic, a wardrobe, a floor, a combustible partition, or similar spaces.
- A flue pipe crossing a combustible wall must have a minimum clearance of 18".
- To reduce flue pipe clearances from combustible materials, contact your local safety department.
- For reduced clearances refer to NFPA 211 table 9-6.6.1.

## **CHIMNEY**

Your wood stove may be hooked up with a factory built or masonry chimney. If you are using a factory built chimney, it must comply with UL 103 standards; therefore it must be a Type HT (2100°F). It is extremely important that it be installed according to the manufacturer's specifications.

If you are using a masonry chimney, it is important that it be built in compliance with the specifications of the National Building Code. It must be lined with fire clay bricks, metal or clay tiles sealed together with fire cement. (Round flues are the most efficient).

The interior diameter of the chimney flues must be identical to the stove's smoke exhaust. (6"). A flue which is too small may cause draught problems, while a large flue favours rapid cooling of the gas, and hence the build-up of creosote and the risk of chimney fires. Note that it is the chimney and not the stove which creates the draught effect; your stove's performance is directly dependent on an adequate draught from your chimney.

**The following recommendations may be useful for the installation of your chimney:**

- 1. Do not connect this unit to a chimney flue serving another appliance.**
- 2. It must rise above the roof at least 3' (0.9 m) from the uppermost point of contact.**
- 3. The chimney must exceed any part of the building or other obstruction within a 10' (3.04 m) distance by a height of 2' (0.6 m).**
- 4. Installation of an interior chimney is always preferable to an exterior chimney. Indeed, the interior chimney will, by definition, be hotter than an exterior chimney, being heated up by the ambient air in the house. Therefore the gas which circulates will cool more slowly, thus reducing the build-up of creosote and the risk of chimney fires.**
- 5. The draught caused by the tendency for hot air to rise will be increased with an interior chimney.**
- 6. Using a fire screen at the extremity of the chimney requires regular inspection in order to insure that it is not obstructed thus blocking the draught, and it should be cleaned when necessary.**
- 7. Clean your chimney every 2 months.**

## CHIMNEY CONNECTOR (STOVE PIPE)

The stove pipe must be made of aluminized or cold roll steel with a minimum thickness of 0.021" or 0.53 mm. It is strictly forbidden to use galvanized steel.

Your smoke pipe should be assembled in such a way that the male section of the pipe faces down. Attach each of the sections to one another with three equidistant metal screws. The system should be attached to the unit using screws.

The pipe must be short and straight. All sections installed horizontally must slope at least 1/4 inch per foot, with the upper end of the section toward the chimney.

To insure a good draught, the diameter of the coupling pipe should be 6" and total length should never exceed 8' to 10' (24 to 3.04 m). (Except for cases of vertical installation, cathedral-roof style where the smoke exhaust system can be much longer and connected without problem to the chimney at the ceiling of the room).

There should never be more than two 90 degrees elbow in the smoke exhaust system.

Installation of a "barometric draught stabiliser" (fireplace register) on a smoke exhaust system is prohibited.

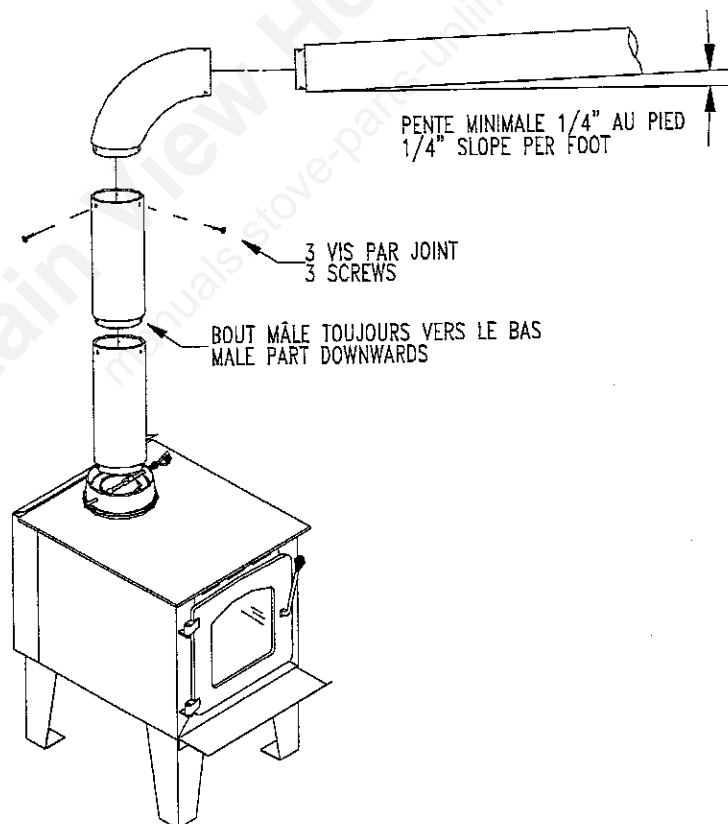

**Stove Pipe**

# TYPICAL INSTALLATIONS

## FACTORY BUILT CHIMNEY:

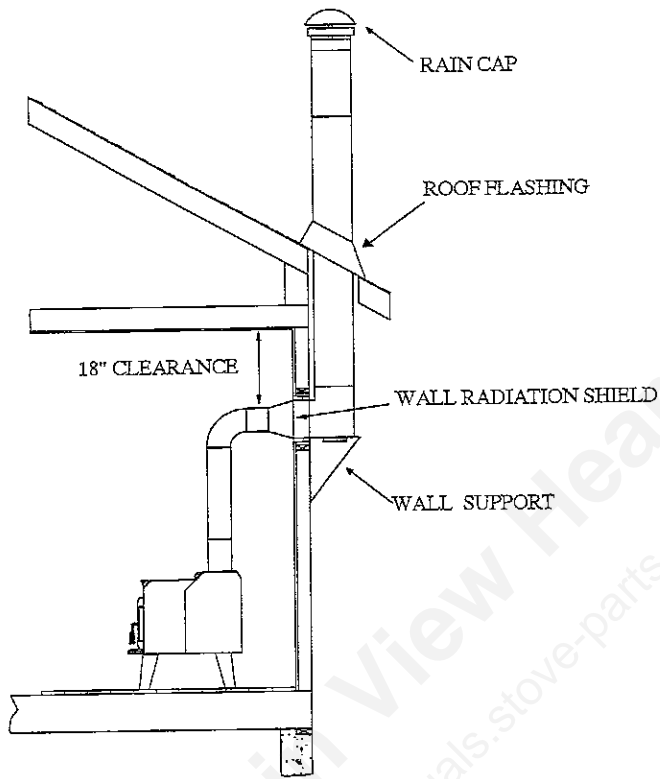

Wall installation

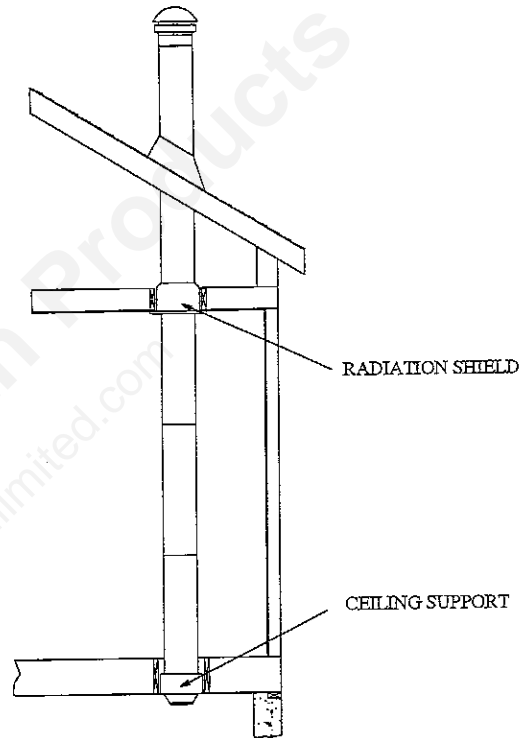

Vertical installation

# FACTORY BUILT THIMBLE:

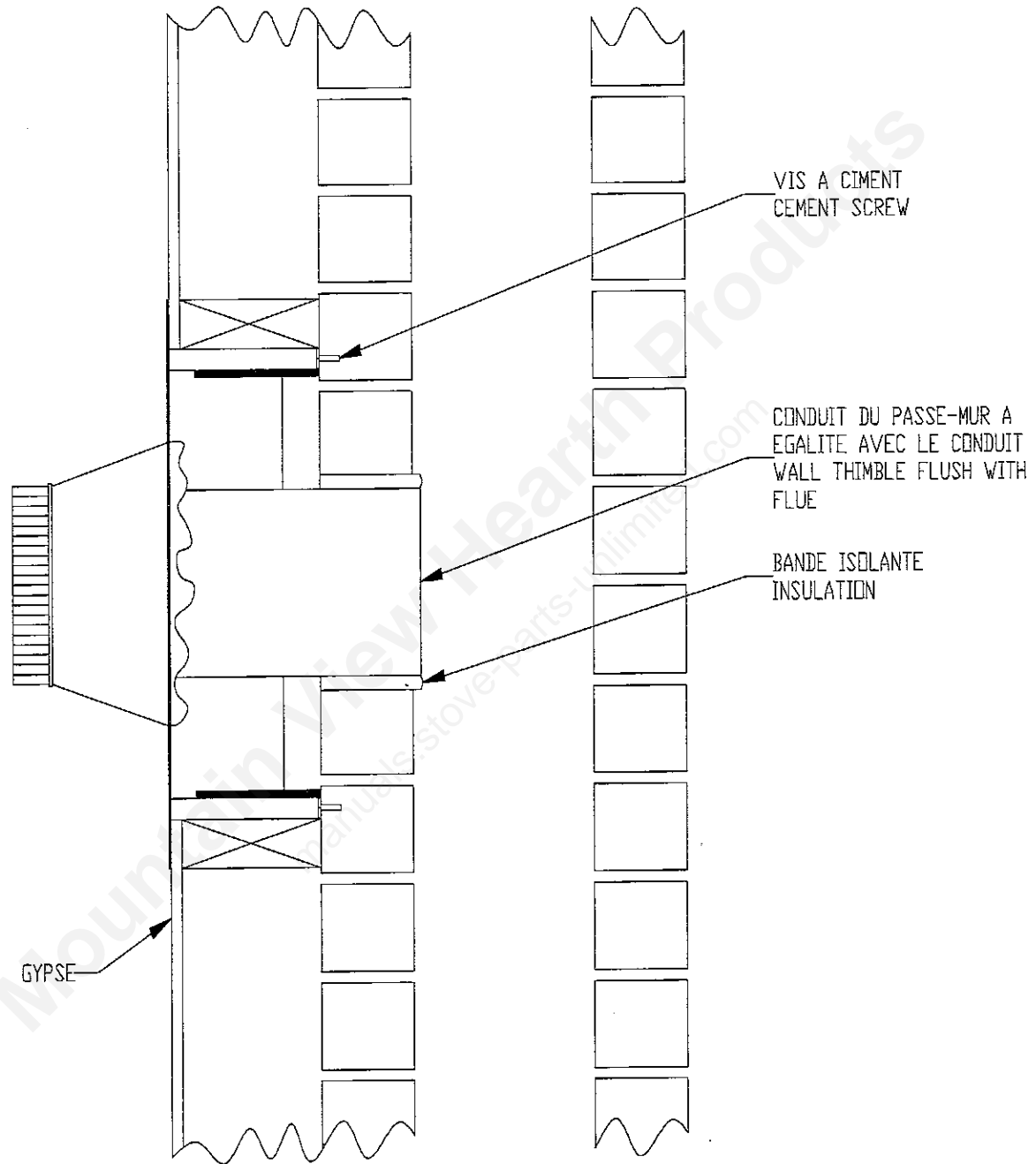

MASONRY CHIMNEY:

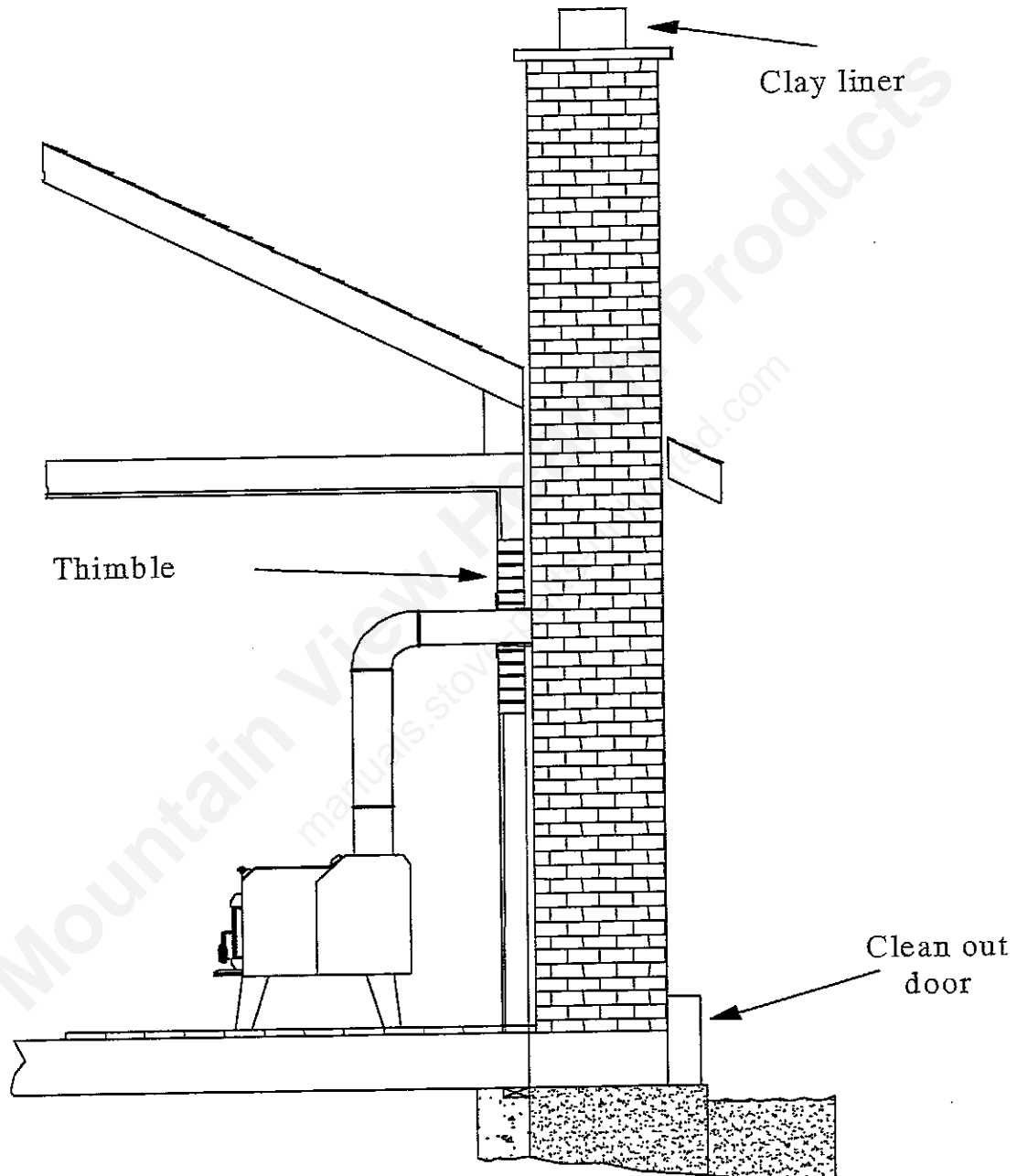

# BRICK THIMBLE:

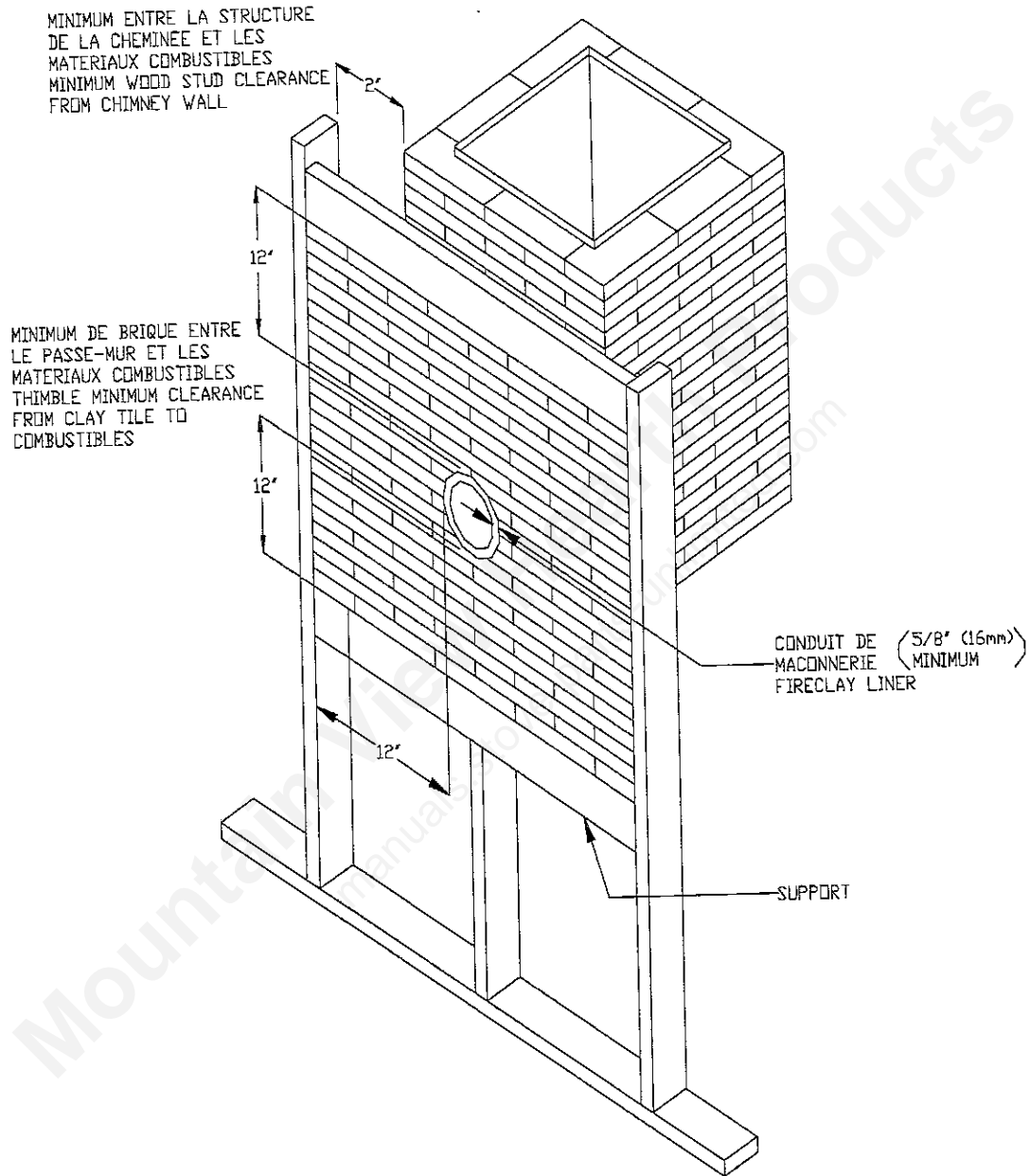

## WOODSTOVE UTILISATION

Your heating unit was designed to burn wood only; no other materials should be burnt. Wastes and other flammable materials should not be burnt in your wood stove. Any type of wood may be used in your stove, but specific varieties have better energy yields than others. Please consult the following table in order to make the best possible choice.

### Average Energy Yield Of One Air Dried Cord Of Cut Wood

	Wood species	Energy yield (millions of BTU/cord)
High energy yield	Oak	29
	Sugar Maple	28
	Beech	26
	Yellow birch	25
	Ash	24
	Elm	23
Medium energy yield	Larch (Tamarack)	23
	Red Maple	23
	Douglas red fir	23
	Silver birch	22
	Alder	18
	Poplar	17
	Hemlock	17
Low energy yield	Spruce	17
	Pine	17
	Bass	16
	Fir	13

Data provided by Energy, Mines and Resources - Canada

**IT IS EXTREMELY IMPORTANT THAT YOU USE DRY WOOD ONLY IN YOUR WOOD STOVE.** The wood must have dried for 9 to 15 months, such that the humidity content (in weight) is reduced below 20% of the weight of the log. It is very important to keep in mind that even if the wood has been cut since one, two or even more years, it is not necessarily dry, if it has been stored in poor conditions; under extreme conditions, it may even rot instead of drying. The vast majority of the problems related to the operation of a wood stove are caused by the fact that the wood used was too damp or had dried in poor conditions. These problems can be:

- ignition problems
- creosote build-up causing chimney fires
- low energy yield
- blackened windows
- incomplete log combustion

Smaller pieces of wood will dry faster. All logs exceeding 6" in diameter should be split. The wood should not be stored directly on the ground. Air should circulate through the cord. A 24" to 48" air space should be left between each row of logs, which should be placed in the sunniest location possible. The upper layer of wood should be protected from the element but not the sides.

## **TESTING YOUR WOOD**

When the stove is thoroughly warmed, place one piece of split wood (about five inches in diameter) parallel to the door on the bed of red embers.

Close the door. If ignition of the piece is accomplished within 90 seconds from the time it was placed in the stove, your wood is correctly dried. If ignition takes longer, your wood is damp.

If your wood hisses and water or vapour escapes at the ends of the piece, your wood is soaked or freshly cut. Do not use this wood in your stove. Large amounts of creosote could be deposited in your chimney, creating potential conditions for a chimney fire.

## **THE FIRST FIRES**

The fresh paint on your stove needs to be cured to preserve its quality. Once the fuel charge is properly ignited, only burn small fires in your stove for the first four hours of operation.

Make sure that there's enough air circulation while curing the stove. The odours could be smelled during the 3 or 4 first fires. Never start your stove outside. You will not be able to see if you are over heating.

## **IGNITION**

Place several crumpled sheets of paper in the centre of the combustion chamber. Place 8 to 10 pieces of small dry kindling wood over the paper in the form of a tent. You may also place a few pieces of heating wood, but choose the smaller ones. No chemical product should be used to light the fire.

Before igniting the paper and kindling wood, it is recommended that you warm up the chimney. This is done in order to avoid back draft problems often due to negative pressure in the house. If such is the case, open a window slightly near the stove and twist together a few sheets of newspaper into a torch. Light up this paper torch and hold it as close as possible to the mouth of the pipe inside the combustion chamber to warm up the chimney. Once the updraft movement is initiated, you are ready to ignite the stove by lighting the paper and kindling wood inside the combustion chamber.

We therefore advise you to leave the door slightly opened (1/4") for a 10 to 30 minutes period, **under supervision**, in order to allow for good combustion. After this time, you must close the door.

## **ASH DISPOSAL**

Ashes should be removed from the stove every few days or when ashes get to 2 to 3 inches deep. Always empty the stove when it is cold, such as in the morning.

Always dispose of ashes in a metal container with a tight fitting lid. Place this container on a non combustible floor or on the ground, well away from all combustible materials, pending final disposal. If the ashes are disposed of by burial in soil or otherwise locally dispersed, they should be retained in the close container until all cinders have thoroughly cooled.

### **CAUTIONS:**

- ASHES COULD CONTAIN HOT EMBERS EVEN AFTER TWO DAYS WITHOUT OPERATING THE STOVE.
- THE ASH PAN CAN BECOME VERY HOT. WEAR GLOVES TO PREVENT INJURY.
- NEVER BURN THE STOVE WITH THE ASH TRAP OPEN. THIS WOULD RESULT IN OVER FIRING THE STOVE. DAMAGE TO THE STOVE AND EVEN HOUSE FIRE MAY RESULT.
- THE INSTALLATION OF A LOG CRADLE IS NOT RECOMMENDED IN YOUR DROLET WOOD STOVE.
- NEVER PUT WOOD ABOVE THE FIREBRICK LINING OF THE FIREBOX.

## AIR CIRCULATION SYSTEM

In order to improve air circulation in the room where the wood stove is installed, certain options are available for specific stove models.

**Blower:** A variable speed-control blower is available. The part number is AC02050.

**Thermodisc:** The thermodisc is installed on the blower's electrical supply cord, and it will start the blower when the stove's temperature reaches 120° F (49°C) and cut off power when the stove cools down below 100° F (37°C). Information regarding installation of the thermodisc is included with the device.

## MAINTENANCE

Your Drolet stove is a high efficiency stove and therefore require little maintenance. It is important to perform a visual inspection of the stove every time it is emptied, in order to insure that no parts have been damaged, in which case repairs must be performed immediately.

### GLASS

- Inspect the glass regularly in order to detect any cracks. If you spot one, turn the stove off immediately. Do not abuse the glass door by striking or slamming shut. Do not use the stove if the glass is broken.
- If the glass on your stove breaks, replace only with glazing supplied from the Drolet dealer.
- To replace the glass, remove the screws retaining the glass mouldings inside the door. Remove the mouldings and replace the damaged piece with a new one. Perform the procedure backwards after replacing. When replacing the glass, you should change the glass gasket to make sure you keep it sealed.
- Never wash the glass with a product that may scratch. Use a specialized product, available in the stores where wood stoves are sold.
- The glass should be washed only when cold.

### GASKETING

It is recommended that you change the door gasket (which makes your stove door air tight) once a year, in order to insure good control over the combustion, maximum efficiency and security. To change the door gasket, simply remove the damaged one. Carefully clean the available gasket groove, apply a high temperature silicone sold for this purpose, and install the new gasket. You may light up your stove again approximately 24 hours after having completed this operation.

**WARNING:**

- NEVERS OPERATE THE STOVE WITHOUT A GASKET OR WITH A BROKEN ONE. DAMAGE TO THE STOVE OR EVEN HOUSE FIRE MAY RESULT

**PAIN**

Only clean your stove with a dry soft clothe that will not harm the paint finish.

If the paint becomes scratched or damaged, it is possible to give your wood stove a brand new look, by repainting it with a 1200° F heat resistant paint. For this purpose, simply scrub the surface to be repainted with fine sand paper, clean it properly, and apply thin coats (2) of paint successively. Refer to page 18 of the present manual for the paint curing process.

Mountain View Hearth Products  
manuals.stove-parts-unlimited.com

# FREQUENTLY ASKED QUESTIONS

## WHAT DO THE WORDS “DRAFT” AND “NEGATIVE PRESSURE” MEAN?

The word “**draft**” refers to the hot air movement that circulates in your stove’s exhaust system, moving from the stove to the outside of the house, and carrying with it the combustion residues. The draft is a natural phenomenon. Hot air weights less than cold air, causing it to rise. This is why the higher the temperature in the exhaust system, the stronger the draft. It is also important to say that the “tunnel effect” created by the exhaust system contributes to increasing the draft effect. This is why chimneys that are excessively long often create excessive draft, while chimneys that are abnormally short will have an excessively low draft. The following are often symptoms of a draft problem:

- Excessively dirty (blackened) glass;
- A fire that has a tendency to die quickly when the stove door is closed;
- A stove that does not heat enough.

“**Negative pressure**” can be seen as a “reverse draft”. That is, air will circulate from the chimney toward the interior of the house. Negative pressure is often what causes smoking problems. In general, negative pressure is the result of either one or a combination of the three factors explained below:

- 1- A cold chimney. Cold air, which is heavier than hot air, has a tendency to go down the chimney and create the effect of a “clog”. This explains why a stove that has not worked for a long time and which chimney is very cold will sometimes be hard to light and cause smoking problems.
- 2- Negative pressure can also be caused by a “vacuum effect” in the room or the house. The air in a house is constantly moving. Hot air rises, cold air moves down. Air can also be mechanically expelled outside of the house with the use of air-moving devices, such as a range hood, a air exchanger, a dryer, a bathroom fan, etc. Furthermore, air goes in and out of the house through cracks, doors, windows, etc. If air leaves a room without being replaced, a “vacuum effect” is created. Therefore, if a house is well insulated and all windows are closed, the room will source its air through the easiest alternative route, which is often your stove’s exhaust system. This creates a negative pressure in your exhaust system. You now understand why it is often suggested that a window be slightly open in the room where the stove is located. This enables the room to easily source its air from outside the house without searching for an alternative route. The vacuum effect can amplified when your stove is located in the basement. This is due to the fact that your house itself acts like a chimney. Since hot air will rise to upper floors, it will “draw” air from the basement of the house. This phenomenon is called the “chimney stack effect”.

- 3- Wind can also be a third cause of negative pressure. When your house is located near a structure which height is superior to your roof's, wind currents can create an interference with your chimney, leading to negative pressure problems.

Drawings #1 to #5 starting on page 18 will help you understand the explanations provided in this section.

Mountain View Hearth Products  
manuals.stove-parts-unlimited.com

DRAWING #1

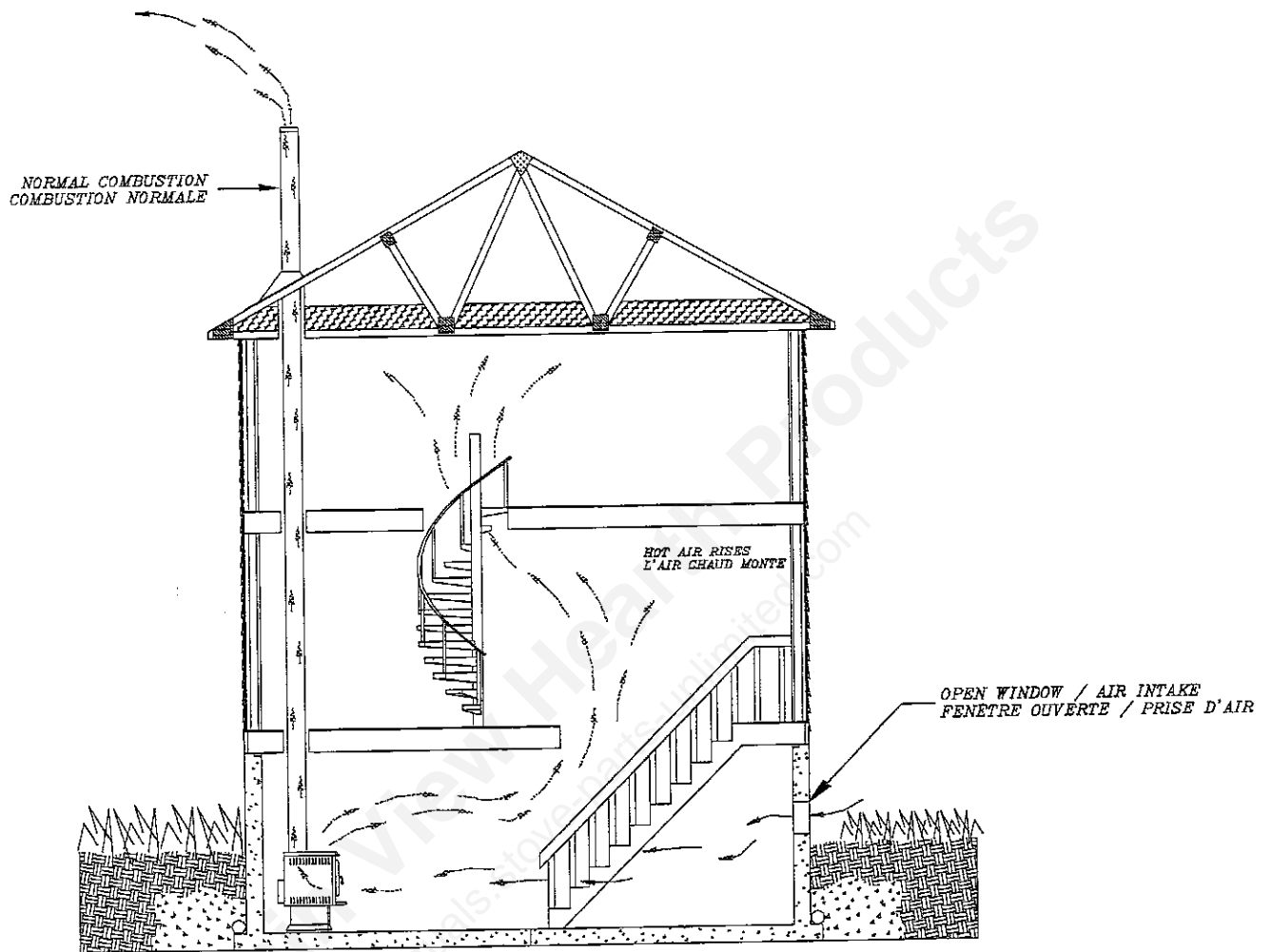

**DRAWING #1** shows a stove functioning under normal and adequate conditions. Heat rises to the upper floors and the room where the stove is located has an adequate supply of oxygen. The chimney draft is sufficient and the combustion gases are evacuated normally through the exhaust system.

DRAWING #2

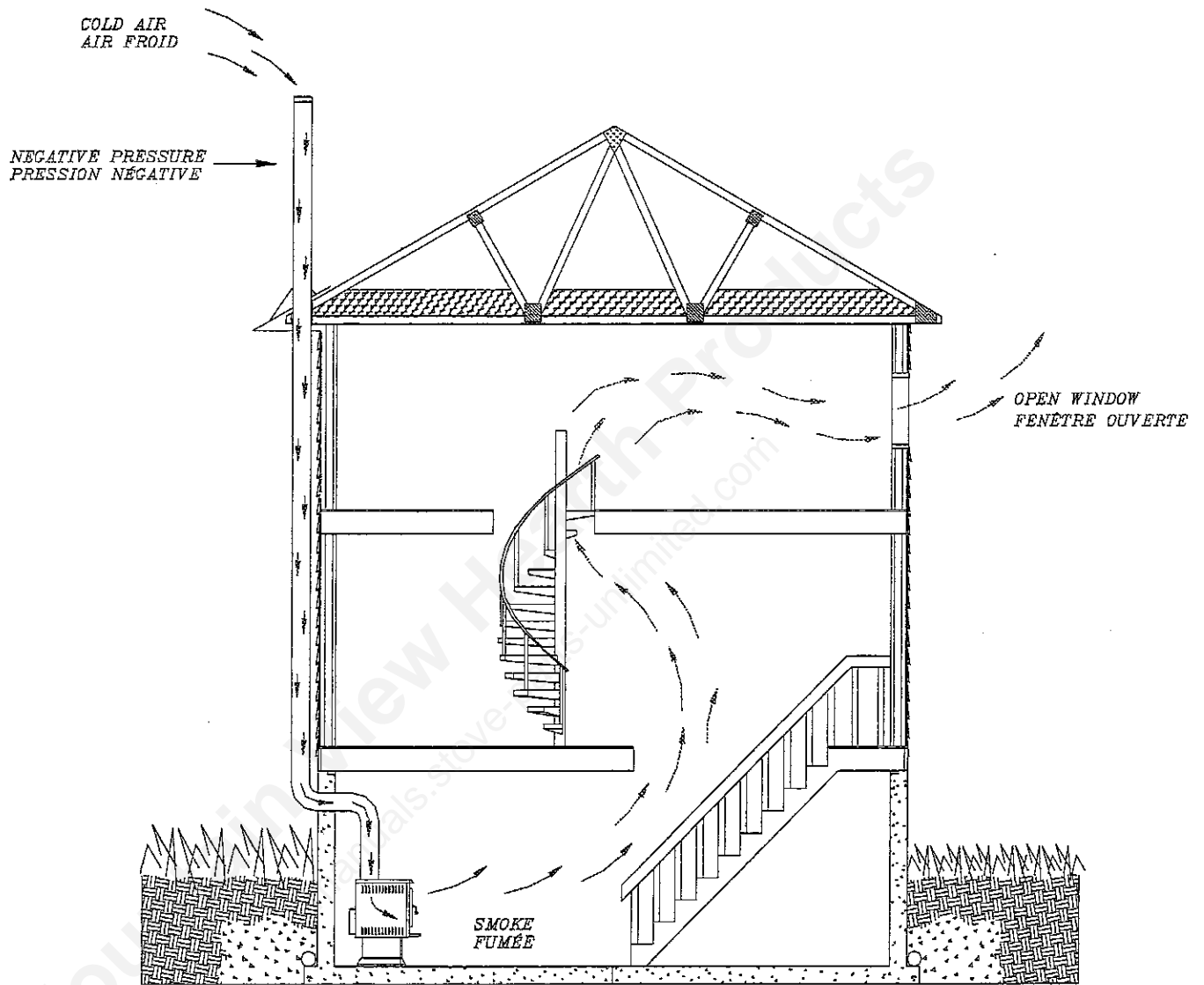

**DRAWING #2 shows the effect of a cold chimney. Cold air creates a reverse draft (negative pressure), which causes smoking problems. This phenomenon is amplified by the fact that heat rises, which creates a draft from the basement of the house to the upper floors ("chimney stack effect").**

DRAWING #3

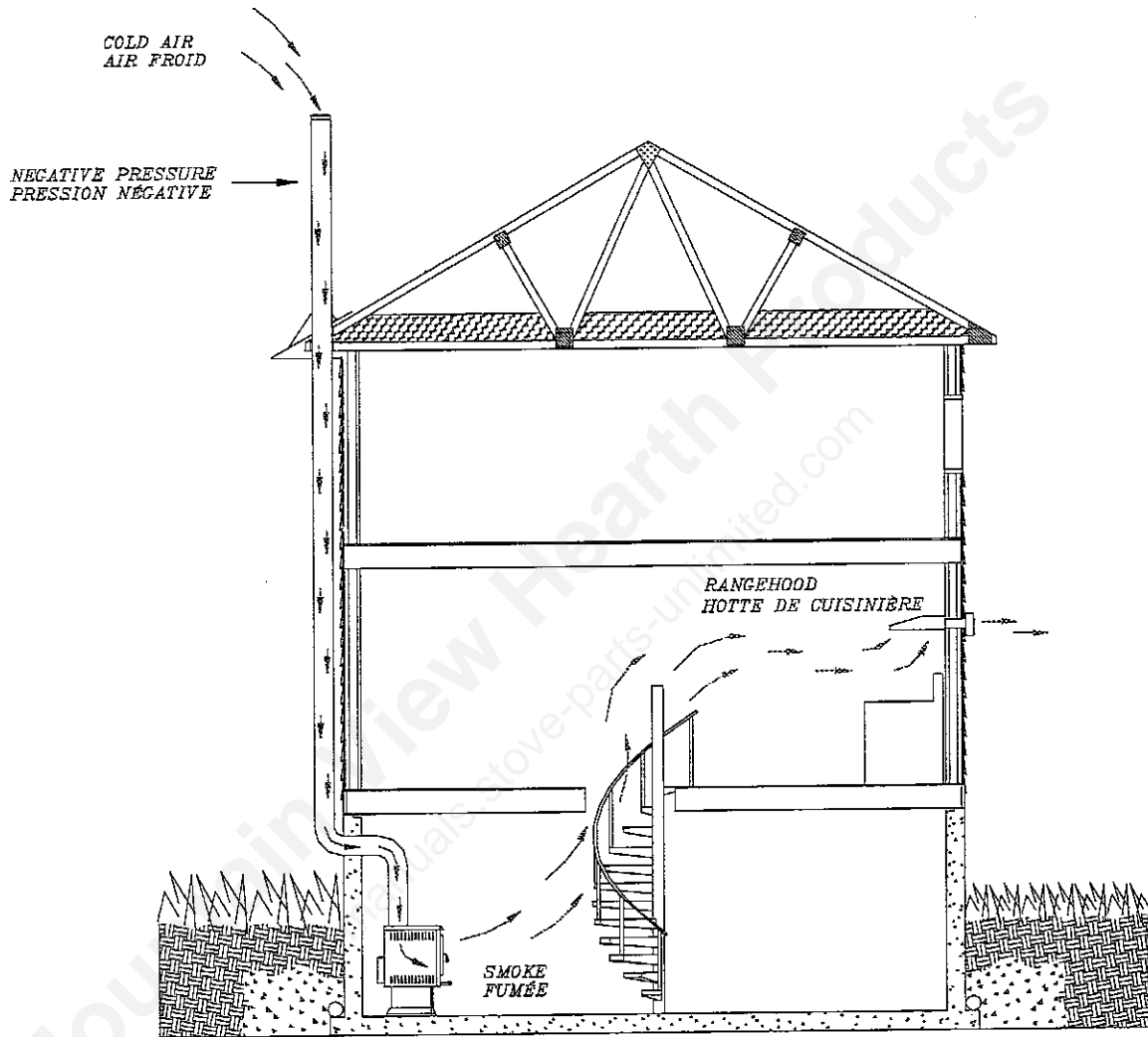

**DRAWING #3 shows the effect of negative pressure caused by an air-moving device inside the house. In the example above, the range hood draws air from inside the house, which is replaced by air coming from the chimney. The result is a smoking problem.**

DRAWING #4

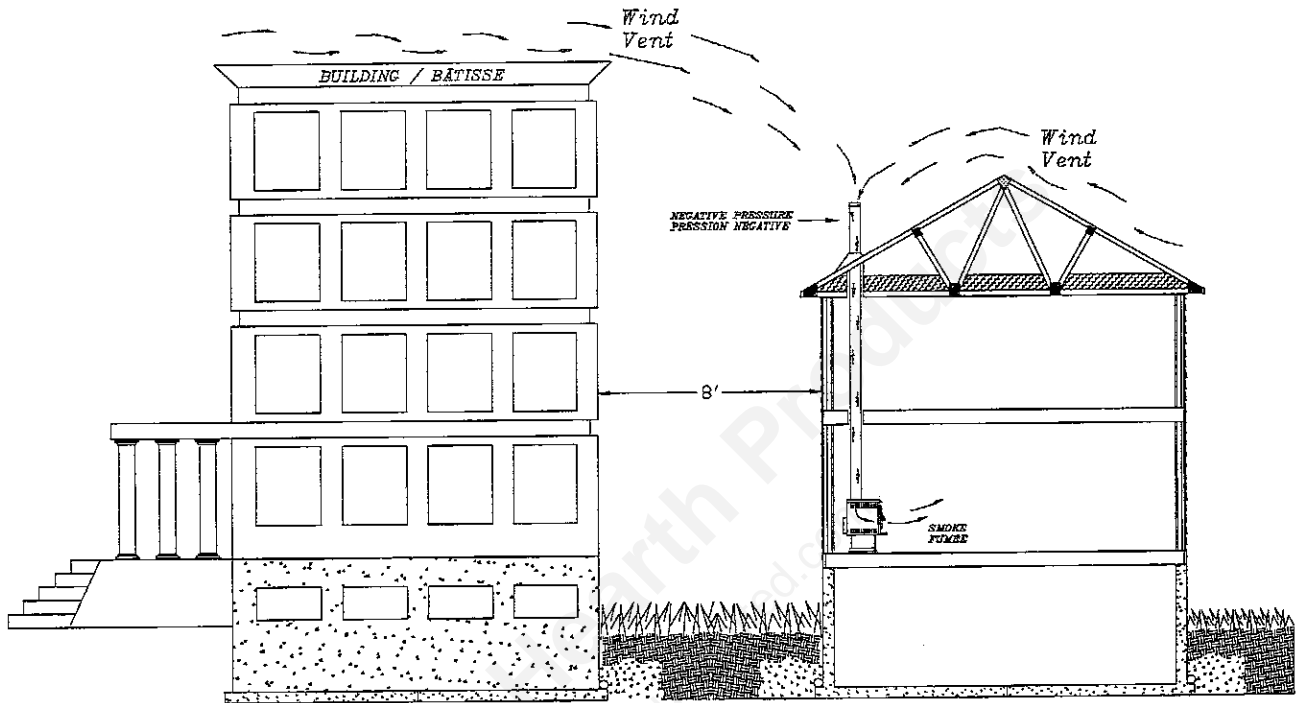

**DRAWING #4 shows the negative pressure effect caused by wind, influenced by nearby structures such as a building.**

Mountain View  
manuals.stove-parts-unlimited.com

DRAWING #5

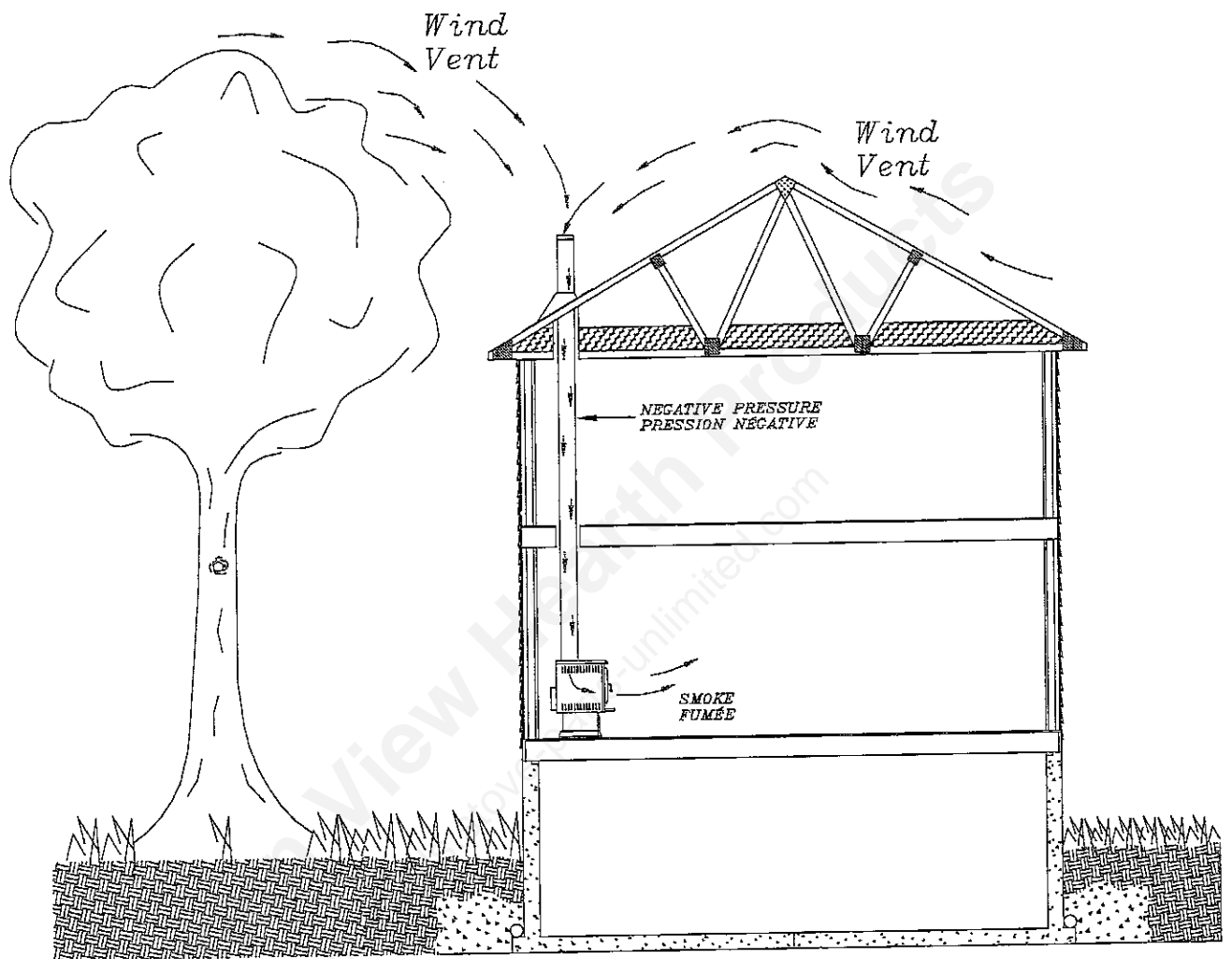

**DRAWING #5 shows the negative pressure effect that can be caused by wind, influenced by nearby structures such as a tree.**

## **CAN I MODIFY MY STOVE TO INSTALL A GLASS DOOR?**

It is forbidden to modify a stove. Stoves are safety tested with a specific configuration, drawings of which are filed with the regulating authorities. Changing the type of door could lead to serious difficulties with your insurance company in case of fire. It would also automatically nullify your warranty.

## **WHEN DO I NEED TO REPLACE THE FIREBRICKS?**

The firebricks in your stove are there to protect the steel from the excessive heat of the flames and embers. Without firebricks, your stove would wear out prematurely. It could also become too hot and cause objects or structures nearby to catch fire. If you notice that some firebricks are disintegrated and the steel is directly in contact with the fire or embers, replace the firebricks immediately. If you only notice cracks on some firebricks, it is not necessary to replace them. The frequency at which you will change your firebricks depends on how often you use your stove.

There are different sizes of firebricks. Most stores will sell firebricks with a dimension of 4,5"X9"X1,25". These firebricks are adequate for many stoves, but will not fit on all Drolet units. It is preferable that you visit our parts section in order to clearly identify the type of firebrick that you need.



Fabricant de poêles international  
Stove Builder International

1700, rue Léon-Harmel, Québec (Québec) G1N 4R9  
tel. : (418) 527-3060 fax : (418) 527-4311  
e-mail : tech@drolet.ca web site : www.drolet.ca

## LIMITED 3 YEARS WARRANTY

The Stove Builder International warranty extends only to the original consumer purchaser and is not transferable. This warranty covers brand new products only, which have not been altered, modified nor repaired since shipment from factory. Proof of purchase (dated bill of sale), model name and serial number must be supplied when making any warranty claim to your Stove Builder International dealer

**This warranty applies to normal residential use only. Damages caused by misuse, abuse, improper installation, lack of maintenance, over firing, negligence or accident during transportation are not covered by this warranty.**

This warranty does not cover any scratch, corrosion or discoloration caused by over firing, abrasives or chemical cleaners. Any defect or damage caused by the use of unauthorized parts or others than original parts void this warranty.

An authorized qualified technician must perform the installation in accordance with the Instructions supplied with this product and all local and national building codes. Any service call related to an improper installation is not covered by this warranty.

Returned products are to be shipped prepaid to Stove Builder International for investigation. If a product is found to be defective, Stove Builder International will repair or replace such defect and reasonable transportation fees will be refund. Repair work covered by the warranty, executed at the purchaser domicile by an authorized qualified technician requires the prior approval of Drolet Stoves & Fireplaces. Labour cost and repair work to the account of Stove Builder International are based on predetermined rate schedule and must not exceed the wholesale price of the replacement part.

Stove Builder International at its discretion may decide to repair or replace any part or unit after inspection and investigation of the defect. Stove Builder International may, at its discretion, fully discharge all obligations with respect to this warranty by refunding the wholesale price of any warranted but defective parts

Stove Builder International shall in no event be responsible for any special, indirect, consequential damages of any nature, which are in excess of the original purchase price of the product.

DESCRIPTION	WARRANTY APPLICATION	
	PARTS	LABOUR
Combustion chamber (weldings only)	3 years	1 year
Carbon steel baffle (perforations)	1 year	1 year
Handle assembly	1 year	n/a
Ash drawer	5 years	1 year
Cast iron parts	3 years	1 year
Ceramic glass (thermal breakage only)	1 year	n/a
Paint, refractory bricks, gasket, blower, thermal switch (thermodisc) and rheostat	n/a	n/a
Gold plating (tarnishing)	n/a	n/a

Shall your unit or a components be defective, contact immediately your Drolet dealer. Prior to your call make sure you have the following information necessary to your warranty claim treatment:

- You name, address and telephone number;
- Serial number and model name as indicated on the nameplate fixed to the back of your unit;
- Bill of sale, dealer's name;
- Nature of the defect and any relevant information.

Before shipping your unit or defective component to our plant, you must obtain from your Drolet dealer an Authorization Number. Any merchandise shipped to our plant without authorization will be refused automatically and returned to sender.



POÊLES & FOYERS / STOVES & FIREPLACES

## LES AVANTAGES DU VENTILATEUR DROLET THE BENEFITS OF INSTALLING A BLOWER

Vous trouverez avec votre manuel du poêle à bois DROLET deux adaptateurs en métal avec quatre vis. Conserver ces pièces précieusement. Elles vous serviront pour installer le ventilateur DROLET sur votre appareil si vous décidez de vous munir de cette option. Un ventilateur permet de redistribuer la chaleur à l'avant de votre poêle. Vous obtenez donc une performance accrue, puisque le ventilateur vous permet d'étendre l'efficacité de convection de votre poêle sur une plus grande surface.

*Vous pouvez acheter le ventilateur par l'intermédiaire d'un détaillant Drolet. Il suffit de commander la pièce #AC02050. Assurez-vous de bien spécifier le numéro de la pièce.*

You will find with your DROLET wood stove instructions manual two steels brackets with four screws. You must keep these parts. You will need them if you want to install a Drolet blower on the back of your stove. A blower is necessary if you wish to redistribute into a room the heat trapped at the back of your stove. By pushing hot air toward the front, the blower allows you to increase the convection efficiency of your stove.

*You can purchase this option through your DROLET dealer. Make sure to specify this part number: #AC02050.*

