



**MARTIN  
INDUSTRIES**

# MODEL PAK INLET AIR KIT

## INSTRUCTIONS

---

### SAFETY PRECAUTIONS

---

THESE INSTRUCTIONS SHOULD BE READ BEFORE BEGINNING THE KIT INSTALLATION, USED AS A GUIDE DURING THE KIT INSTALLATION, AND SAVED FOR FUTURE REFERENCE.

THE INSTALLER SHOULD CONTACT LOCAL BUILDING OR FIRE OFFICIALS ABOUT RESTRICTIONS AND INSTALLATION INSPECTION REQUIREMENTS IN YOUR AREA.

---

### USAGE

---

Two regulations established by the Federal Department of Housing and Urban Development (HUD) for solid fuel-burning appliances installed in mobile homes require that any solid fuel-burning appliance installed in a mobile home (1) be connected to an outside source of combustion air, and (2) be firmly attached to the floor of the mobile home.

To satisfy the above-two HUD regulations, the PAK Inlet Air Kit has been designed for installation with certain solid fuel-burning appliances manufactured at Martin Industries. Check your appliance owner's manual to see if the PAK Inlet Air Kit is right for your particular appliance; if unable to determine by your appliance owner's manual, check with your appliance dealer. THE PAK INLET AIR KIT IS NOT COMPATIBLE TO ALL SOLID FUEL-BURNING APPLIANCES.

---

### KIT COMPONENTS

---

Each PAK Inlet Air Kit contains an assortment of fasteners to install the following PAK kit components. See Figure 1 of these instructions for typical usage of the PAK kit; see Figures 2 and 3 for typical installation.

COMPONENT NAME	COMPONENT PART NUMBER	QUANTITY PER KIT
AIR SUPPLY DUCT	060308	1 EACH
AIR PLENUM	060309	1 EACH
HOLD DOWN BRACKET	060307	2 EACH

Inspect the kit for damaged or missing components. See your dealer for replacement of any damaged or missing component.

FIGURE 1

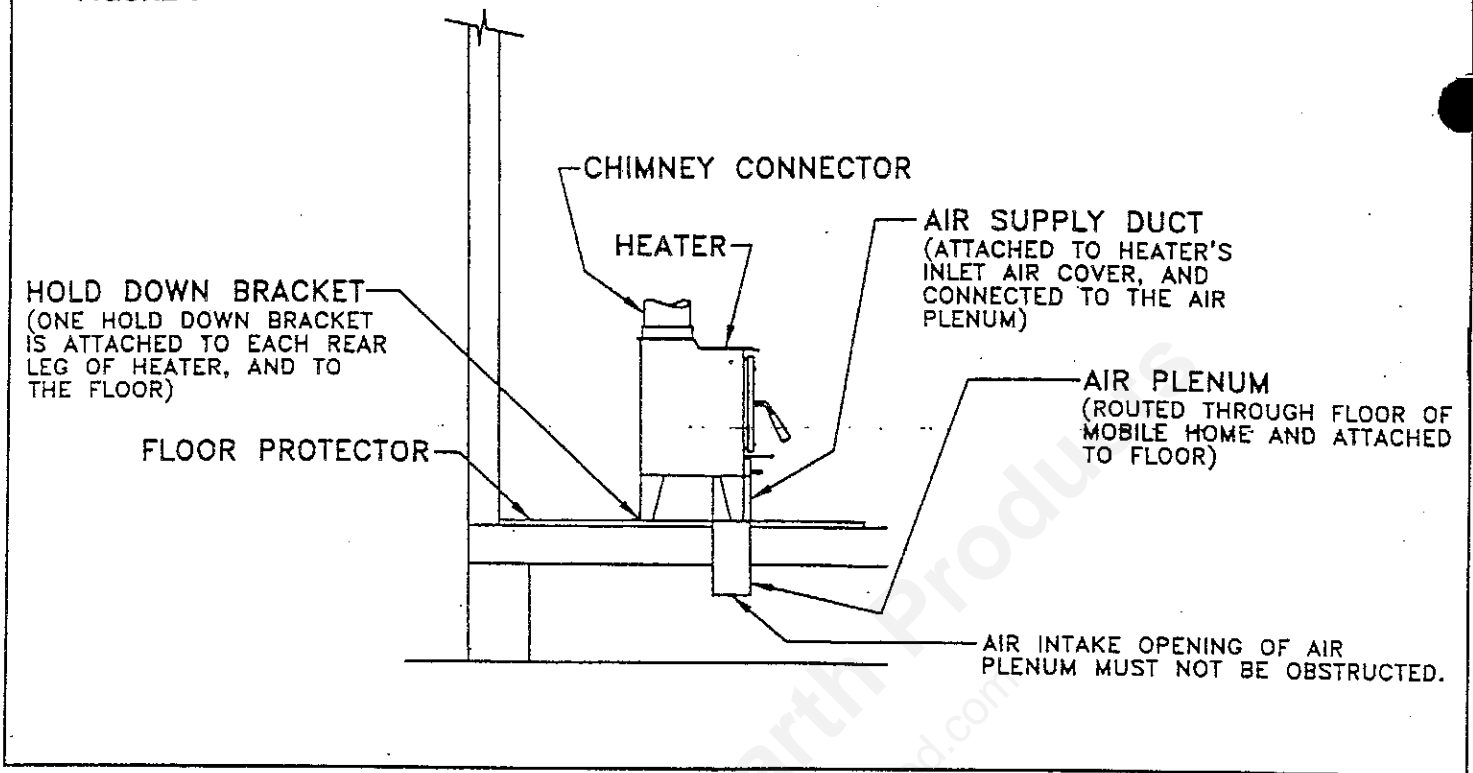

#### TOOLS AND SUPPLIES NEEDED FOR INSTALLATION

pencil	screwdriver	drill
ruler or tape measure	adjustable wrench	drill bits
		saw

#### INSTALLATION

USE THE FOLLOWING NUMBERED STEPS AS A GUIDE TO INSTALL THE PAK INLET AIR KIT.

1. Position the heater and floor protector in the exact locations at which they are to be installed. See the heater's instruction manual for details.
2. Mark the location of the floor protector on the floor and mark the location of the heater on the floor protector so that each may be removed and then put back at the same location during installation of the PAK kit.
3. Place the two hold down brackets against the heater's two rear legs as shown by Figure 2. Using the holes in each hold down bracket as guides, mark the locations for corresponding attachment-holes on the heater's rear legs and on the floor protector. Remove the hold down brackets for later installation.
4. Align the two holes in the air supply duct with the two holes in the heater's inlet air cover as shown by Figure 3. Using the bottom perimeter of the air supply duct as a template, mark the location of the air supply duct on the floor protector. Remove the air supply duct for later installation.
5. Remove the heater from the floor protector. Drill a 3/16-inch diameter hole thru each of the heater's rear legs and thru the floor protector at the locations marked by step 3 above.
6. Cut a hole thru the floor protector at the location marked by step 4 above. The hole should be the same size at the perimeter of the air supply duct.

7. Insert the air plenum into the hole cut by step 6 above. Mark the location of the holes in the flanges of the air plenum on the floor protector. Drill 3/16-inch diameter holes at those locations after removing the air plenum. See Figure 3.
  8. Put the floor protector on the floor at the location marked by step 2 above. Mark and cut a hole thru the floor to match the hole cut by step 6 above. (Note: Remove the floor protector before cutting the hole in the floor).
- CAUTION: THE STRUCTURAL INTEGRITY OF THE MOBILE HOME MUST BE MAINTAINED. IDEALLY, NO STRUCTURAL MEMBER OF THE MOBILE HOME SHOULD BE CUT DURING THE PAK KIT INSTALLATION. HOWEVER, IF A STRUCTURAL MEMBER MUST BE CUT, REFRAMING AND REINFORCING IS ADVISABLE.
9. Put the floor protector back at the location marked by step 2 above. Insert the air plenum thru the floor protector and floor as shown by Figure 3. Fasten the air plenum in place by driving eight screws thru the holes in the air plenum flanges and into the floor as shown by Figure 3.
  10. Place the air supply duct on top of the air plenum so that the top portion of the air plenum inserts into the bottom portion of the air supply duct. See Figure 3.
  11. Put the heater on the floor protector at the location marked by step 2 above. Fasten the air supply duct to the heater's inlet air cover with two screws. See Figure 3.
  12. Fasten the two hold down brackets to the rear legs of the heater and to the floor by utilizing the holes drilled by step 5 above. See Figure 2 for fasteners to be used.

After installing the PAK inlet air kit, finish installing the heater per instructions furnished with the heater. When ready, operate the heater in accordance with instructions furnished with it.

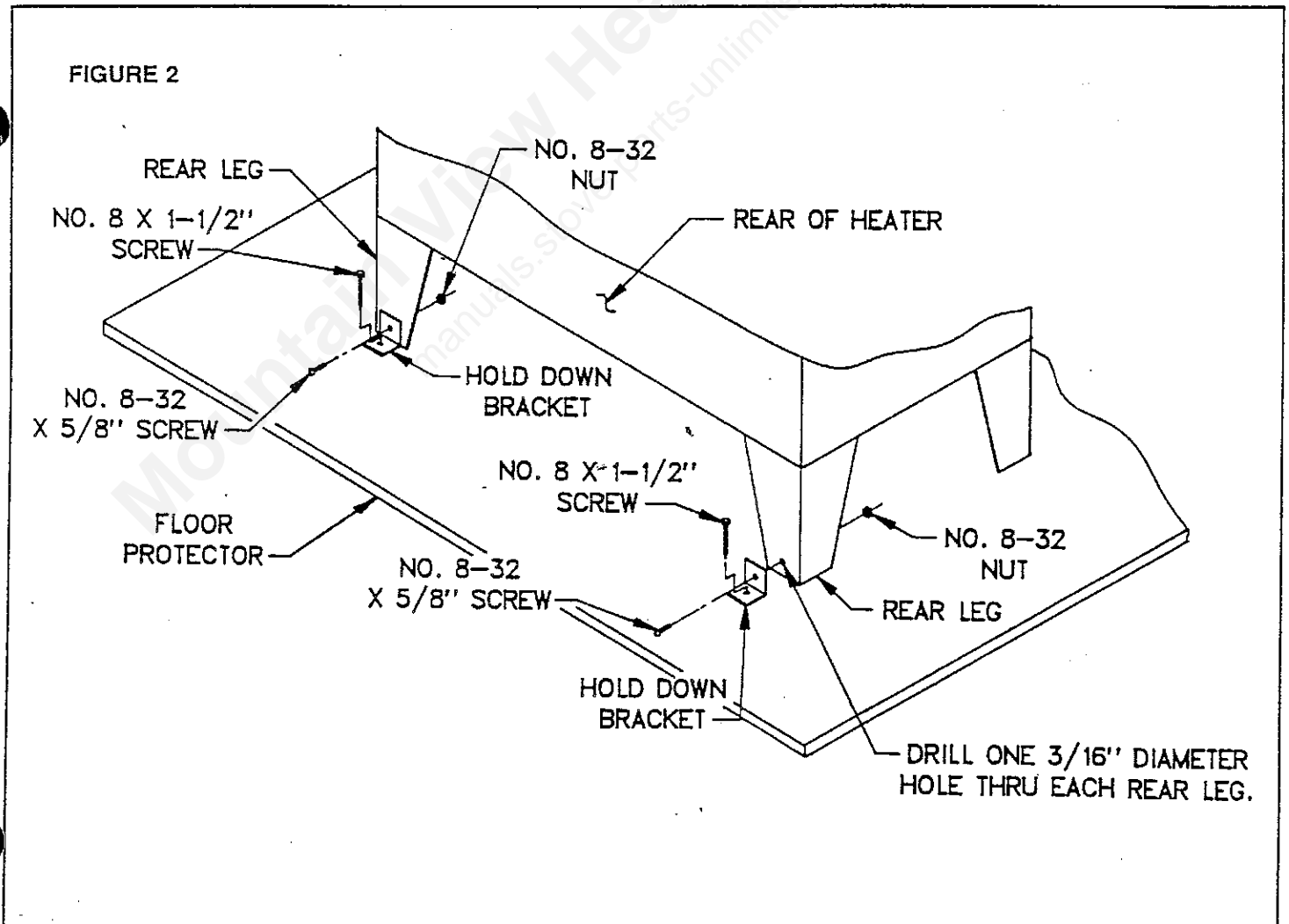
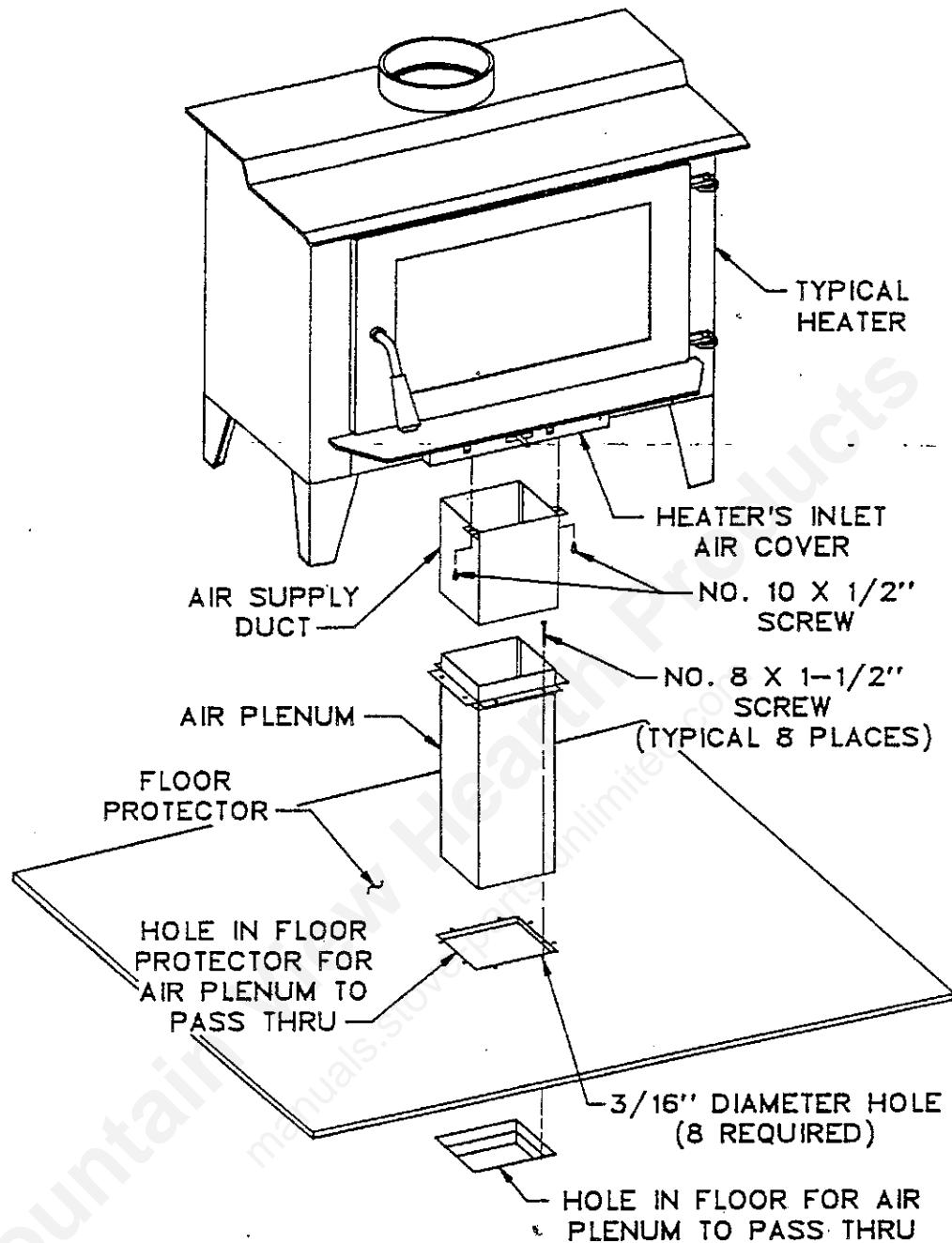

FIGURE 3



### MAINTENANCE

Open ventilation should be maintained to the crawl space beneath the mobile home to ensure that an adequate supply of air may be provided by the PAK inlet air kit.

Keep the inlet air kit free of dirt, lint, grass, leaves, and anything else which could obstruct air input to the heater.

When cleaning is necessary, the outer surfaces of the inlet air kit may be wiped free of dust with a soft cloth. Mild soap suds applied with a soft cloth may also be used; wipe dry with a clean, dry, soft cloth after cleaning with soap suds. Touch-up paint is available from your dealer if needed.

**KEEP FLAMMABLE FUMES AWAY FROM THE AIR INTAKE OPENING OF THE AIR PLENUM. SEE FIGURE 1.**

UNITED STATES STOVE CO.  
P.O. BOX 151  
227 INDUSTRIAL PARK RD.  
SOUTH PITTSBURG, TN 37380

MARTIN INDUSTRIES, INC.  
SOLID FUEL DIVISION  
P.O. Box 128 • Florence, AL 35631  
Phone: 205-767-0330  
Fax: 205-740-5192