

**Owners Manual
Model 2937
WONDERCOAL**

THERMOSTAT CONTROLLED COAL BURNING CIRCULATOR

- *ASSEMBLY
- *INSTALLATION
- *OPERATION
- *REPAIR PARTS

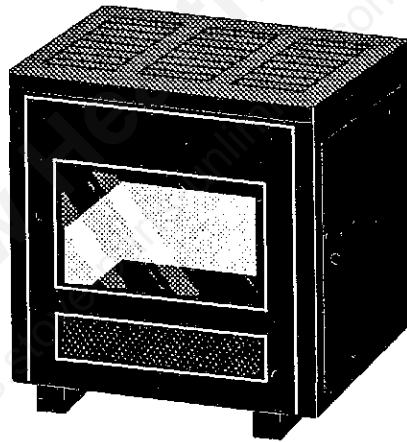

SAFETY NOTICE:

If this heater is not properly installed, a house fire may result.
For your safety, follow the installation directions.
Contact local building or fire officials about restrictions and
inspection requirements in your area.

CAUTION:

Read all instructions carefully before starting the installation
or operation of this heater.
Improper installation may void your warranty.

DO NOT USE THIS HEATER IN A MOBILE HOME OR TRAILER



United States Stove Company

227 Industrial Park Rd.
South Pittsburg, TN 37380
(615) 837-2100



851138 3/95

TOOLS AND MATERIAL NEEDED

TOOLS

Pencil
 6 Foot Rolding rule or tape
 Tin Snips
 Drill, hand or electric
 Drill bit, 1/8" dia.
 (for sheet metal screws)
 Gloves
 Screwdriver (blade-type)
 5/16" Nut Driver or
 5/16" Socket w/Ratchet

MATERIALS

Chimney Connection- 6" Dia. Black
 Steel (24 Ga. minimum): Straight or
 Elbow (as required)
 1/2" Sheet Metal Screws
 6" Inside Diameter Unerwriters
 Laboratories (UL) listed Residential
 Type and Building Heating Appliance
 Chimney, Type "HT", or 6" existing
 Masonry Chimney with flue liner.
 Floor Protector Material: 3' x 4'-6" as
 specified on page 4.
 Furnace Cement (Manufacturer
 recommends: Rutland Code 78 or
 Equivalent)

CIRCULATOR DIMENSIONS

Fig. 1

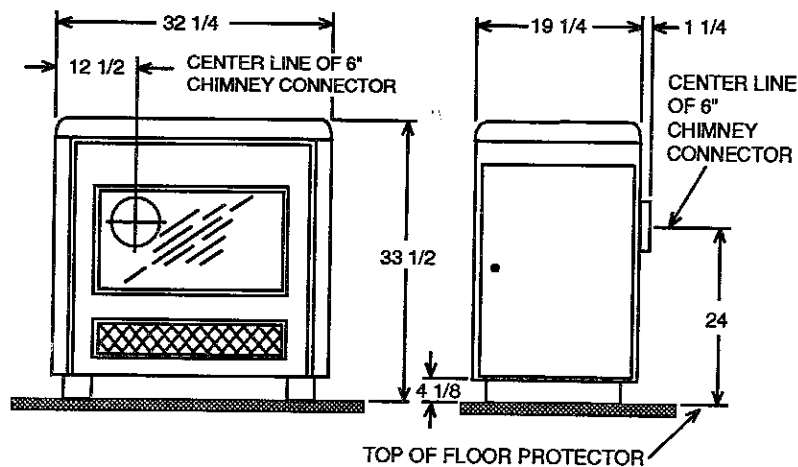

RULES FOR SAFE INSTALLATION AND OPERATION

Read these rules and the instructions carefully.

SAFETY NOTICE: If this heater is not properly installed, a house fire may result. For your safety, follow the installation directions. Contact local building or fire officials about restrictions and installation inspection requirements in your area.

1. Check local codes. The installation must comply with their rulings. Do not install this heater in a mobile home or trailer.
2. Always connect this heater to a chimney or vent to the outside. Never vent to another room or inside a building.
3. Do not connect a COAL burning heater to an aluminum Type B gas vent. This is not safe and is prohibited by all codes. This heater requires connection to approved chimneys: Either a factory built 6" UL 103HT or a lined and approved and recently inspected and cleaned masonry chimney with a 6" flue, preferably round. A larger masonry flue may be used, so long as the flue-section diameter is not greater than 50 sq. in.
The chimney portion (whether factory-built or masonry) must be tall enough to provide sufficient draft and safe exit of smoke and combustion products. Please refer to Page 5.
4. Be sure that your Chimney is safely constructed and in good repair. Have the chimney inspected by the Fire Department or a qualified inspector (such as a Chimney sweep). Your insurance company may be able to recommend a qualified inspector.
5. Inspect chimney connector and chimney twice monthly during the heating season for any deposit of creosote or soot which must be removed (see Chimney Maintenance, page 13).
6. Provide air for combustion from outside the house into the room where the heater is located. If the intake is not in the same room, air must have free access to the room.
7. CAST IRON PARTS MUST BE "SEASONED" TO AVOID CRACKING. BUILD ONLY SMALL FIRES ON FIRST USE.
8. To prevent injury, do not allow anyone to use this heater who is unfamiliar with the correct operation of the heater. Do not allow children to use or in any way operate this heater.
9. For further information on using your heater safely, obtain a copy of the National Fire Protection Association (NFPA) publication "Using Coal and Wood Stoves Safely" NFPA No. HS-10-1978. The address of the NFPA is Battery March Park, Quincy, MA. 02269.
10. Keep the ash pit section free of excess ashes. Do not allow ashes to stack higher than the sides of the ash pan.
11. DISPOSAL OF ASHES- Ashes should be placed in a metal container with a tight fitting lid. Keep the closed container on a non-combustible floor or on the ground, well away from all combustible materials. Keep the ashes in the closed container until all cinders have thoroughly cooled. The ashes may be buried in the ground or picked up by a refuse collector.
12. CAUTION: The special paints used on your heater may give off some smoke while they are curing during first few fires. Build small fires at first. The metals used in construction of the heater has a light coating of oil. This could give off smoke and/or odors when heater is used for the first couple of times. This should disappear after a short period of time. Once this burn-off has occurred, it should not reoccur.
13. CARING FOR PAINTED PARTS- This heater has a painted outside jacket, which is durable but it will not stand rough handling or abuse. When installing your heater, use care in handling. Clean with soap and warm water when heater is not hot. DO NOT use any harsh chemicals (acids or caustics) or scouring powder, as these wear and dull the finish.
14. KEEP THE FEED DOOR, ASH DOOR AND CABINET DOOR CLOSED AT ALL TIMES EXCEPT WHILE TENDING THE HEATER. DO NOT OVERFIRE THE HEATER. THIS WILL HAPPEN IF THE FEED DOOR, OR PARTICULARLY THE ASH DOOR, IS LEFT OPEN DURING OPERATION. UNDER EXTREME CONDITIONS THIS CAN PRODUCE DANGEROUS RESULTS. AS A MINIMUM, IT WILL ALLOW THE PAINT TO DISCOLOR.

CAUTION: DO NOT TOUCH THE HEATER UNTIL IT HAS COOLED. ALWAYS WEAR GLOVES WHEN REFUELING THIS UNIT OR WORKING WITH METAL CABINET PARTS.

LOCATING THE HEATER

AS A LOCATION IS SELECTED,
KEEP THE FOLLOWING IN MIND:

1. The chimney connection should be as possible. The heater must have its own chimney. Do not connect this unit to a chimney flue, serving another appliance. If there is no chimney near where you wish to place the heater, you can use a UL 103HT Residential Type and Building Heating Appliance Chimney (Fig. 5 & 6).

**NOTE: BEFORE FIRING
HEATER**

1. Remove plastic knob from inside of cabinet door and install on outside of door. (See Page 15)
2. Slide firebricks toward the rear so no gaps remain between them.

2. Place the heater on solid masonry or solid concrete. When the heater is used on a combustible floor protector of one layer of 3/8" millboard having a thermal conductivity of $K=0.84$ BTU in./ft. 2 hr. Deg. F with 28-gauge sheet metal or a UL Listed floor protector. Have the floor protector extend 16" beyond the door side of the heater and under the connector pipe in the back.

CAUTION:
Keep furnishings and other
combustible materials away
from the heater.

3. Check Figures 2, 3, and 4. Be sure you have the clearances shown from the heater and the connector pipe to combustible surfaces. If you have a solid brick or stone wall behind your heater, you can place the heater as close as you wish to the wall. If the wall is only faced with brick or stone, treat it as a combustible wall.

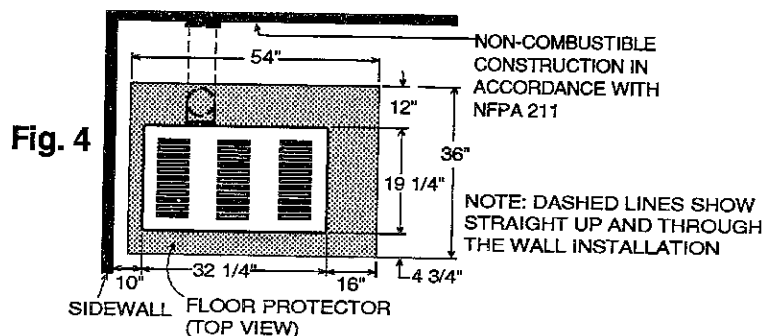
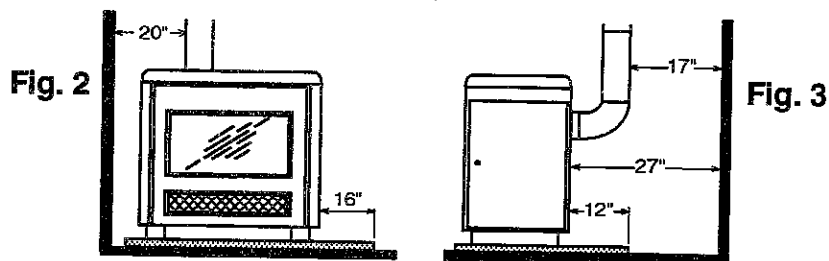

CHIMNEY CONNECTION

Two basic types of chimneys are approved for use with solid fuel: Factory-built and masonry. Factory-built chimney must comply with UL103HT standard.

Do not expect your stove or furnace to create draft. Draft is not a function of the appliance. Draft is purely a function of the chimney. Modern stoves and furnaces are much more air-tight and efficient than those of the past; and, therefore require greater draft. A minimum of .05, measured in water column (gauges to measure chimney draft are readily available at stove shops and are economical to purchase or rent) is required for proper drafting to prevent back-puffing, smoke spillage, and to maximize performance.

Chimneys perform two functions - one of which is apparent: The chimney provides a means for exhausting smoke and flue gases resulting from combustion of the fuel. Secondly, though, the chimney provides "Draft" which allows oxygen to be continuously introduced into the appliance, so that proper combustion is possible. As of April 1, 1987, all heaters and furnaces manufactured by United States Stove Company should be installed using a factory built chimney that meets the "Type HT" requirement of UL 103 (when a factory - built chimney is used).

IMPORTANT

- *Size the chimney to the flue outlet on the stove. (6" outlet = 6" I.D. chimney)
- *Avoid using elbows except as necessary (they reduce draft).
- *Make sure all horizontal runs of connector pipe go up hill (1/4" elevation for each horizontal foot).

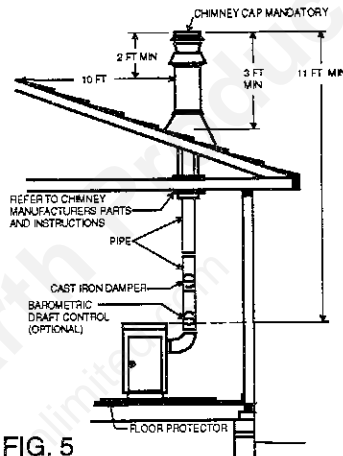

FIG. 5

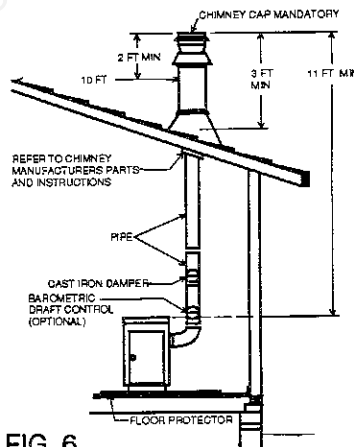

FIG. 6

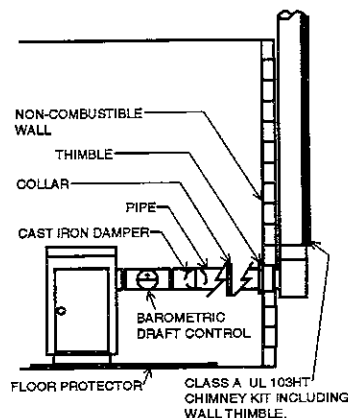

FIG. 6-1

VENTING INTO A FIREPLACE (Not recommended)

Many people may wish to convert an existing fireplace to heater use. Usually, safe connection of stovepipe to a masonry chimney requires more effort than connection to a prefabricated chimney. The fireplace must be closed and sealed at the damper in the flue. Good sealants are high temperature caulking, ceramic wool, and furnace cement. Always remember to inspect the masonry chimney and fireplace. If necessary, clean the flue and smoke shelf before beginning your installation. Install the heater into the chimney so that the system can be dismantled for cleaning and inspection.

Before deciding to convert your fireplace or existing chimney, keep in mind that older fireplaces and their chimneys are unsafe. They must be structurally sound, and the flue liner must be in good condition. **Do not use a chimney if it is unlined (should have a tile clay liner to protect brickwork), have it relined professionally.** Clearances to combustibles are explained in the previous section on masonry chimneys. If you have any questions regarding the condition of the chimney, consult a qualified engineer, competent mason, certified Chimney Sweep, or knowledgeable inspector.

**CAUTION:
NOT ALL FIREPLACES
ARE SUITABLE FOR
INSTALLATION OF A COAL
HEATER.**

Many prefabricated fireplaces fall into the "zero-clearance fireplace" category. This is a factory metal fireplace with multi-layered construction. It is designed to provide enough insulation and/or air cooling so that the base, back and sides can be safely placed in direct contact with combustible floors and walls. Although many prefabricated fireplaces have been tested by nationally recognized organizations for use as fireplaces, they have not been tested to accept heaters. In fact, their use as such may void the manufacturer's warranty.

Steel-lined fireplaces, on the other hand, can be used with heaters. These units use a 1/4-inch fire box liner and an air chamber in connection with 8 inches of masonry to meet code. They contain all the essential parts of a fireplace, firebox, damper, throat, smoke shelf, and smoke chamber. Many of them look exactly like a masonry fireplace and must be checked closely for above requirements before installing a coal heater into them.

Another method frequently used by some people is to vent the heater directly into the fireplace. This does not meet code since the heater is being vented into another appliance - the fireplace. This method should not be attempted because combustion products will deposit and build up in the firebox or fireplace. Be certain not to install a hazard in your house. **You will void your warranty with this installation.**

FIREPLACE INSTALLATION

Connection of the stovepipe directly into the existing masonry chimney over the fireplace opening is the only approved method. This installation performs better, yielding easy to clean and inspect for creosote. Before beginning this type of installation plan carefully; a high degree of skill is required to insure safety.

An entry port for the stovepipe must be cut through the chimney with minimum damage to the fire clay liner. Some involved measurements may be required to locate the flue liner exactly. Before cutting, take time to mark the size and position of the entry port. Position the entry port so that at least 8 inches of the flue liner remains below the port.

Keep in mind that wood mantels and combustible trim around the fireplace must have adequate clearances from the heater and stovepipe or must be protected in an approved manner. Also, be sure to leave at least 24" clearance between the top of the stovepipe and the combustible ceiling or other combustibles. Placing the center of the entry port 2 feet below the ceiling will insure proper clearance for 6 inch, 8 inch, and 10 inch stovepipes. Next, install a fire clay (at least 5/8 in. thick) or metal thimble, being sure that the thimble is flush with the inner flue lining, secure the thimble in place with refractory mortar. The thimble should be surrounded on all sides with 8 inches of brickwork (solid masonry units) or 24 inches of stone.

Install the stovepipe as far as possible into the thimble, but not past the inside of the flue lining. There should be a small air space (approximately 1/2 in.) between the stovepipe and thimble,

Install the stovepipe as far as possible into the thimble, but not past the inside of the flue lining. There should be a small air space (approximately 1/2 in.) between the stovepipe and thimble, allowing for expansion of the stovepipe. Seal this airspace with high-temperature caulking or ceramic wool. Finally, be sure to wire the damper close and apply the same sealant you used at the stovepipe and thimble junction.

Do not vent up through the fireplace opening, regardless of whether the fireplace opening is closed.

Masonry chimneys have several positive attributes: If properly built, they are quite durable, and most homeowners consider them more attractive perhaps than a nonenclosed factory built chimney.

And, if the chimney is located within the confines of the house (that is, not attached to an exterior wall), its mass alone will store heat longer and continue to release the heat long after the fire has died. Masonry chimneys have many disadvantages though.

Masonry chimneys constructed on an exterior wall are exposed to cold outdoor temperatures, promoting greater heater loss, higher accumulations of creosote, and reduced draft which leads to poorer heater or furnace performance.

When considering a masonry chimney, round tiles are preferable to square or rectangular, as round tiles have much better airflow characteristics and are far easier to clean. Unfortunately, most North American chimneys use square or rectangular tile liners that are really designed for open fireplaces, not stoves or furnaces. Of most importance, second only to overall chimney height, is the diameter of the flue liner itself. In most instances, it should be sized to the appliance; i.e., 6" flue outlet on the appliance requires a 6" chimney. The inner diameter should never be less than the flue outlet diameter and should never be greater than 50% of the appliance flue outlet. For example, do not expect a wood burning stove or furnace to function properly if installed into a chimney with a flue liner greater than 50% of the appliance outlet – such as a 6" flue outlet requires a 6" diameter for optimum drafting, but can function well with an 8", but becomes borderline beyond 8" diameter.

Masonry chimneys built of concrete blocks with flue liners of at least 5/8" fireclay do not meet modern building codes. A solid fuel appliance must not be joined to a chimney flue which is connected to another appliance burning other fuels.

If your chimney has a typically oversized flue liner of 8x12 inches or greater, or if it is unlined, it will be necessary for you to re-line the chimney, using many of the modern approved and economical methods such as stainless steel, castable refractory, or properly sized fireclay linings.

If you have any question regarding venting your appliance, feel free to contact the factory at the address and phone number on this Owner's Manual. You may also contact NFPA (National Fire Protection Association) and request NFPA Standard 211 (1984 Edition). Their address is Battery March Park, Quincy, Massachusetts 02269. Another helpful publication is NFPA Standard 908, available at the same address. Specify 1984 Edition on either of the above publications.

TYPE "A" FIREPLACE CONVERSION

Fig. 7

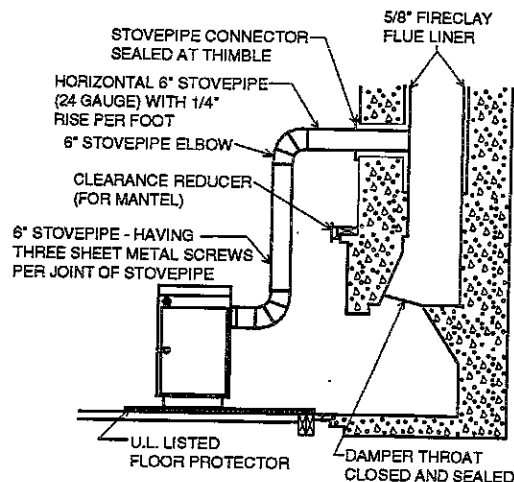

RULES FOR CONNECTOR PIPE INSTALLATION

1. The crimped end of the stovepipe fits inside the heater flue collar. Install additional pipe and elbow with the **CRIMPED END TOWARD THE HEATER**. This will allow any condensation in the flue to run back into the heater.
2. Slope any horizontal pipe upward toward the chimney at least 1/4 inch for each foot of horizontal run.
3. You must have at least 18 inches of clearance between any horizontal piping and the ceiling.
4. The pipe cannot extend into the chimney flue. (Fig. 8)
5. Seal each connector pipe joint with furnace cement. Also seal the pipe at the chimney.
6. Use 3 Sheet Metal screws at each joint to make the piping rigid.
7. It is recommended that no more than two 90 degree bends be used in the stovepipe installation as more than two may decrease the amount of draw and possible, use only corrugated (non-adjustable) elbows. They are much more airtight.
8. The chimney connector must not pass through an attic or roof space, closet, or any concealed space, or floor, ceiling, wall or combustible construction.

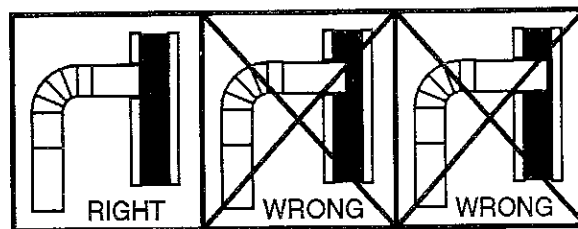

Fig. 8

OPERATING INSTRUCTIONS

FUEL

Egg size Bituminous coal for residential furnaces, or any of the specially packaged fireplaces coals can be used. Coal with a low ash content (2% to 6%) is recommended.

NOTE: Store coal in a dry, well-ventilated area.

LIGHTING

1. Set the thermostat on "High" for maximum draft.
2. Open the feed door and place paper and kindling on the grate for starting the fire.
3. Light fire and close feed door.
4. Add about 15 pounds of coal depending on model after fire is burning briskly. Use care not to smother the kindling fire. Set higher or lower for your comfort.
5. Set thermostat for desired temperature.

ADDING FUEL

When starting a fire, add small amounts of fuel periodically as required (enough to burn for 3 to 5 hours). As you become more familiar with the operation of your heater, it is possible to add coal to burn for longer durations of between 8 to 12 hours, but doing so carelessly will promote incomplete combustion and considerable soot, along with a very dirty inefficient fire.

1. Set thermostat to HIGH before opening feed door.
2. Coal Fire- Never smother the fire when adding coal (see CAUTION below). Gas accumulation and a mild smoky explosion will occur:
 - a. Add fresh kindling if the bed of coals has cooled.
 - b. Add up to 20 lbs. of coal. Never add coal above top of the firebrick.
 - c. Stir the coal and watch the fire. Be sure the new coal is burning before you close the doors and turn the thermostat down.

3. Shake Grates vigorously back and forth to dump ashes into ash pan. Do this at least once every 12 hours of operation.

4. Empty ash pan regularly. Do not allow ashes to build up to grate, as grate will warp and burn out, and you might spill the ashes when removing the pan. Dispose of hot ashes properly. (See note 11 on page 3)

CAUTION: BUILD A FIRE ON INTEGRAL GRATE THAT IS PROVIDED WITH THE HEATER.

MINIMUM FIRE

The burning rate at the low setting can be further adjusted by opening or closing the minimum fire air shutter (Fig. 9) on the draft control door.

1. Partially close the shutter to make the fuel burn longer.
2. Open the shutter, exposing a large opening, to reduce the formation of creosote on soot (see notes on Chimney Maintenance).
3. Do not operate the heater with the minimum fire air shutter completely closed.

CAUTION: DONOT OVERFIRE THE HEATER, AS STATED EARLIER. THIS CAN PRODUCE A DANGEROUS CONDITION AND EVEN CAUSE A HOUSE FIRE. IF ANY PORTION OF THE HEATER OR ANY CHIMNEY CONNECTOR GLOWS RED OR DISCOLORS, THE HEATER IS BEING OVERFIRED.

CAUTION: DO NOT OPERATE THIS HEATER WITH FEED OR ASH DOOR OPEN. THIS HEATER IS DESIGNED FOR THERMOSTATIC OPERATION. OPERATION WITH EITHER DOOR OPEN WILL OVERHEAT AND DAMAGE THE HEATER.

CAUTION: NEVER STORE FLAMMABLE LIQUIDS, ESPECIALLY GASOLINE, IN THE VICINITY OF THE HEATER.

CAUTION: GASES THAT ARE DRIVEN FROM FRESH COAL MUST BE BURNED OR THEY WILL ACCUMULATE AND EXPLODE. NEVER SMOTHER A FIRE WHEN ADDING FRESH COAL.

CAUTION: NEVER USE GASOLINE, GASOLINE-TYPE LANTERN FUEL, KEROSENE, CHARCOAL LIGHTER FLUID, OR SIMILAR LIQUIDS TO START OR "FRESHEN UP" A FIRE IN

CAUTION: NEVER USE THE MANUFACTURED COAL BRICKS THAT ARE MADE FROM COAL DUST AND A WAX-TYPE BINDER.

WARNING: THE USE OF WOOD IN THIS STOVE EXCEPT FOR COAL IGNITION PURPOSES, IS A VIOLA-

ADJUSTING THE THERMOSTAT

The thermostat control was calibrated at the factory. The operation of the heater may require a change in calibration. Calibration adjustments should be made at room temperature.

If the room temperature is not satisfactory, the thermostat operating range may be changed as follows:

- A. To increase the amount of heat at a "HIGH" setting, adjust the wire linkage to increase the draft damper opening (Fig. 9).
1. Unhook linkage wire at point C
 2. Take point A in left hand and B right hand then turn B clockwise about 3 turns.
 3. Then hook linkage wire back to draft control damper door at point C.
- B. To decrease the amount of heat at "LOW" setting:
1. Check feed and ash doors to be sure that they are closed tightly.
 2. Check the connector pipe to see that it is sealed in the flue collar and at all joints.
 3. If no air leaks are found, adjust linkage the same as above, except turn B counterclockwise about 3 turns.

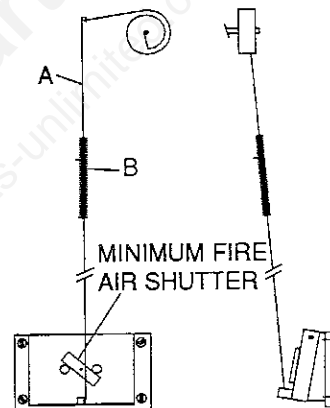

Fig. 9

NOTE: More than one recalibration may be necessary. At room temp. (72°F) and "Low" setting, the draft damper door should be closed.

- C. Adjusting the minimum Air Shutter:
- The minimum air shutter has an infinite number of settings. Several adjustments may be necessary for the unit to work most effectively for your particular installation.
1. The minimum air shutter may be adjusted to the closed position in installations where the draft is "above normal". Generally, .06 w.c. or above would be considered "above normal".
 2. In installation where the draft is "below normal", the minimum air shutter would be adjusted toward the open position.

SUGGESTIONS FOR BURNING ANTHRACITE COAL

1. With coal it is important to maintain a clean chimney. The chimney connector and chimney should be inspected at least twice monthly during heating season.
2. Keep the grate clear of ash and cinders. Use the shaker grate to keep the ashes from building up in the firebox.
3. Do not operate the unit with the ash door, feed door, or cabinet door open.
4. Anthracite coal burns with a short, blue flame with the coals having a glowing, red color. Before adding coal, when starting the fire, have a good hot log fire burning.
5. After having a log fire burning, add small amounts of coal until a bed of coal is built up.
6. A draft reading of $-.05$ to $-.06$ in w.c. is required for anthracite to burn.

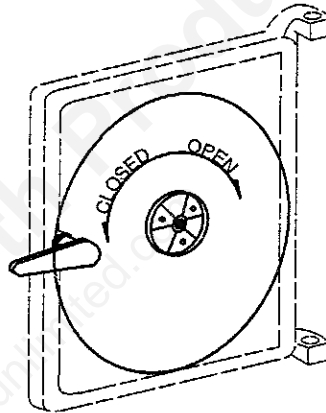

Fig. 10

The draft wheel located on the feed door should be opened when burning coal. The draft wheel provides a source of secondary air that is needed when burning coal. Secondary air is needed because when coal burns, it gives off large quantities of volatile gases that need additional air before complete combustion can occur. This draft wheel may be adjusted to give the best performance depending on the particular needs of the user.

TROUBLE SHOOTING TIPS FOR MODEL 2937

LIST OF PROBLEMS	POSSIBLE CAUSE	SOLUTION
1. Smoking when feed door is open.	A) Insufficient Draft. B) Clogged chimney or chimney connector.	A) Set Thermostat high B) Clean Chimney C) Add raincap to chimney
2. Flame spillage when feed door is open.	A) Insufficient Draft. B) Smothering fire when adding fresh fuel.	A) Set Thermostat high B) Add fuel so as not to smother fire.
3. Creosote build-up	A) Burning green wood B) Thermostat setting too low type fuel.	A) Burn only seasoned wood. B) Set thermostat higher to attain higher fuel temperatures. This will aid in preventing build-up of creosote.
4. Heater does not heat.	A) Wood not seasoned B) Blower control set too low. C) Insufficient flue draft.	A) Allow wood to season in a dry, well ventilated area for 6 months. B) Set blower control to a higher temperature. C) Set flue draft (See Page 9)

SERVICE HINTS

Do not expect a heater to draw. It is the chimney that creates the draft. Smoke spillage into the house or excessive build-up of water or creosote in the chimney are warnings that the chimney is not functioning properly. Possible causes are:

1. The connection pipe may be pushed into the chimney too far, stopping the draft (Fig. 8).
2. Do not connect two heaters into the same chimney flue.
3. The chimney used for a heater must not be used to ventilate the cellar or basement. If there is a cleanout opening at the base of the chimney, it must be closed tightly.

4. If the chimney is too cool, water will condense in the chimney and run back into the stove. Creosote formation will be rapid and may block the chimney. Operate the heater at a high enough fire to keep the chimney warm preventing this condensation.

5. If the fire burns well, but sometimes smokes or burns slowly, it may be caused by the chimney top being lower than another part of the house or a nearby tree. The wind blowing over a house or a tree falls on top of the chimney like water over a dam, beating down the smoke. The top of the chimney should be at least 3 feet higher than any point of the roof within 10 feet (Fig. 6).

NOTE:

A draft reading of .05 to .06 w.c. is suggested for proper burning of this unit when using bituminous coal as fuel. When using anthracite coal, this draft reading is a minimum reading.

CHIMNEY MAINTENANCE

CREOSOTE-FORMATION AND NEED FOR REMOVAL

When coal is burned, the products of combustion combine with moisture to form a soot residue which accumulates on the flue lining. When ignited, this soot makes an extremely hot fire.

The chimney connector should be inspected at least twice monthly during the heating season to determine if a creosote buildup has occurred.

If creosote has accumulated, it should be removed. Failure to remove creosote or soot may cause a house fire. Creosote may be removed by using a chimney brush or other commonly available materials.

Chimney fires burn very hot -- up to 2100 degrees F. If you experience a chimney fire, immediately call the fire department. They have the professional means for extinguishing a chimney fire. Once a chimney fire has occurred, it can only be extinguished by removing it's source of oxygen. This can be accomplished by shutting any mechanical draft device such as dampers, discharging a CO₂ (carbon dioxide) or halon fire extinguisher directly inot the stove through an appropriately placed cleanout. If using a Halon extinguisher, please remember that it totally displaces oxygen and could become a hazard in itself if enough were discharged into a living space.

CAUTION

A chimney fire may cause ignition of wall studs or rafters which you thought were safe distance from the chimney. If you have a chimney fire, have your chimney inspected by a qualified person before using again.

INSTRUCTIONS FOR TWO-STEP LATCH OPERATION

1. Follow these instructions to operate your unit safely when operating the feed door.
2. Turn handle clockwise to the 12 o'clock position, pull the door open until you engage the second step (Fig. 11).
3. Hold the door in that position for approximately 10 seconds.
4. Then to open door, turn the handle counter clockwise to the 9 o'clock position and then continue to pull the door open. (Fig. 11A)
5. To close and latch the door, reverse steps 2 thru 4.

NOTE:
THIS NEW LATCHING MECHANISM MEETS CODES AND PROVIDES MORE SAFETY FOR THE USER OF THIS STOVE.

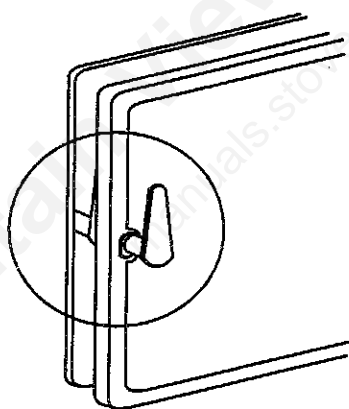

Fig. 11

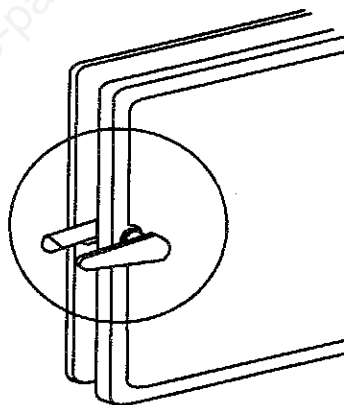

Fig. 11A

68602 S. V. WONDERCOAL LATCH KIT (2 WAY)

NOTE:
DURING OPENING AND CLOSING OF THE FEED AND ASH DOORS OF THIS HEATER, IT MAY SEEM THAT THE FIT OF THE DOOR IS "TOO TIGHT". AS THE HEATER IS FIRED, THE GASKETING "SETTLES" OR "SEATS" ITSELF IN THE DOOR. THE TIGHT FIT AT THE FACTORY AND BEFORE THE HEATER'S INITIAL FIRING IS TO INSURE A GOOD SEAL AFTER THE GASKETING "SETTLES".

CABINET DOOR KNOB ASSEMBLY

The door knob is mounted inside of the cabinet door to facilitate shipping and must be reversed for proper usage.

To get cabinet door open, place hand under cabinet frame (right hand side of cabinet door) and push door out.

INSTALL THE CABINET DOOR KNOB USING THE STEPS BELOW:

1. Remove the machine screw and door knob (Fig. 13).
2. Place door knob on outside of cabinet door. Then place machine screw through hole and into door knob and tighten (Fig. 14).

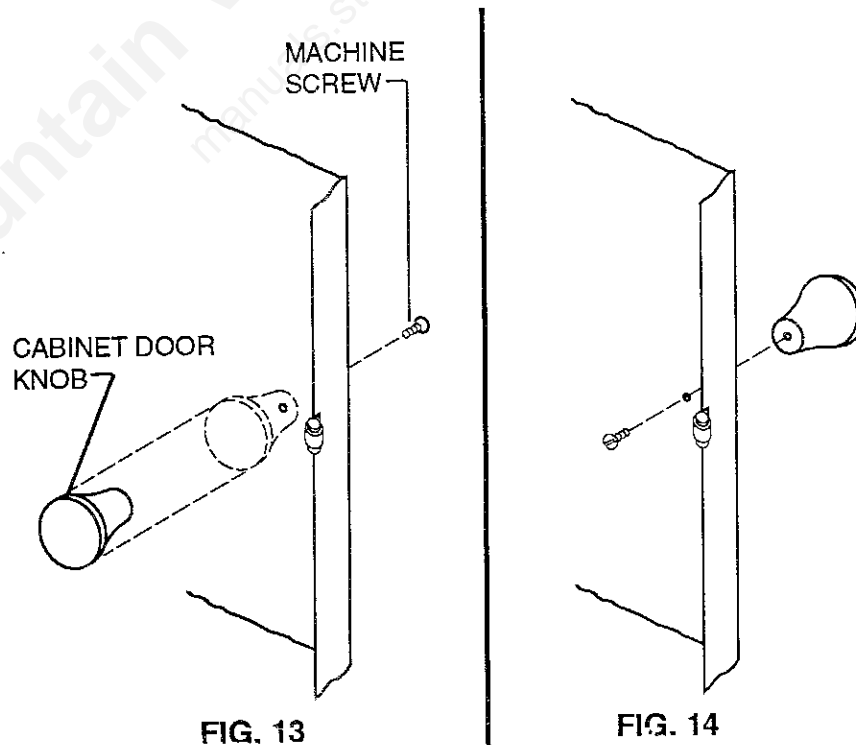

REPAIR PARTS
AUTOMATIC COAL BURNING CIRCULATOR HEATER
MODEL 2937 - EXTERIOR

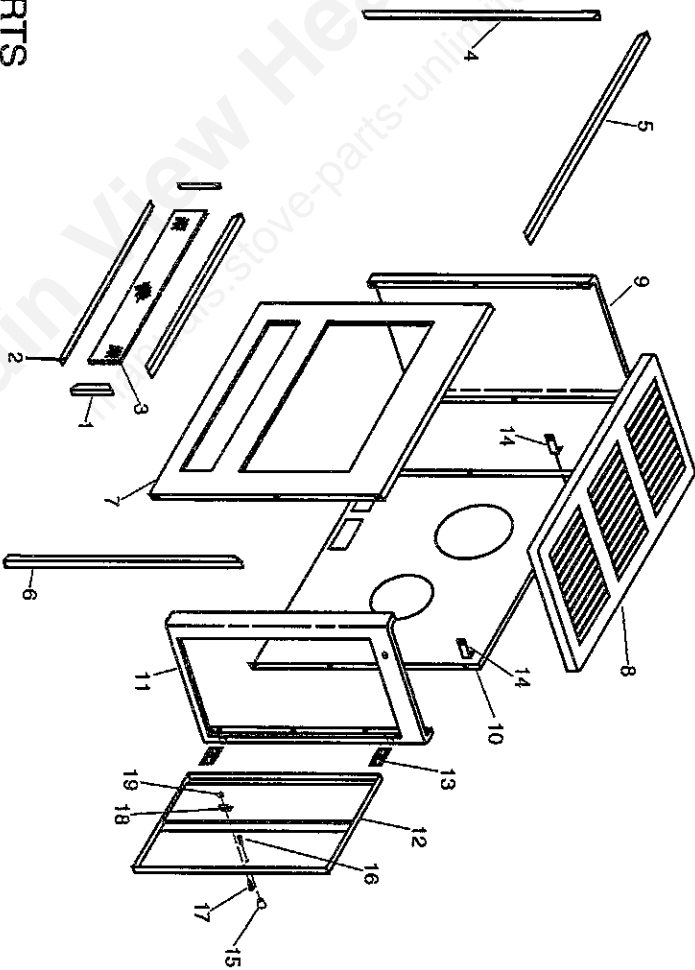

REPAIR PARTS

AUTOMATIC COAL BURNING CIRCULATOR HEATER

MODEL NUMBER 2937
(SEE PAGE 16)

REPAIR PARTS LIST

KEY NO.	PART NO.	DESCRIPTION	QTY.
1	89411	Mesh Brass Trim (LH/RH)	2
2	89410	Mesh Brass Trim (TOP, BOTTOM)	2
3	23230	Cabinet Front Mesh	1
4	89413	Cabinet Front Brass Trim (left)	1
5	89414	Cabinet Top Brass Trim	1
6	89412	Cabinet Front Brass Trim (Right)	1
7	23377	Cabinet Front	1
8	22118	Cabinet Top	1
9	68439	Cabinet Left Side	1
10	66440	Cabinet Back	1
11	68573	Cabinet Right Side	1
12	68236	Cabinet Door	1
13	89065	Door Hinge	1
14	21063	Back Brace	2
15	89062	Door Knob	1
16	83033	Machine Screw (8-32x1/4)	1
17	83005	Machine Screw (10-24x1/2)	1
18	83093	Spring Latch	1
19	83244	Nut (Kep, 10-24 Plain)	1

REPAIR PARTS
AUTOMATIC COAL BURNING CIRCULATOR HEATER
MODEL 2937 - INTERIOR

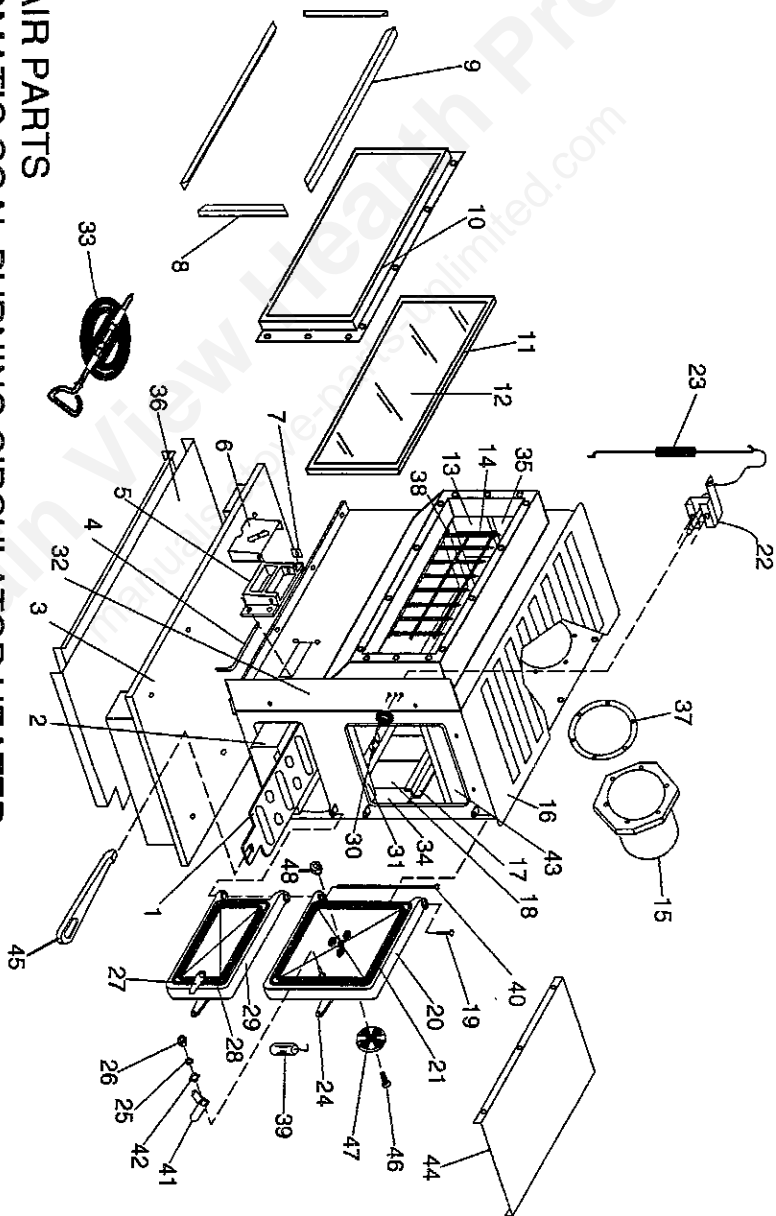

CORRECTION TO PAGE 18

REPAIR PARTS AUTOMATIC COAL BURNING CIRCULATOR HEATER MODEL 2937 - INTERIOR

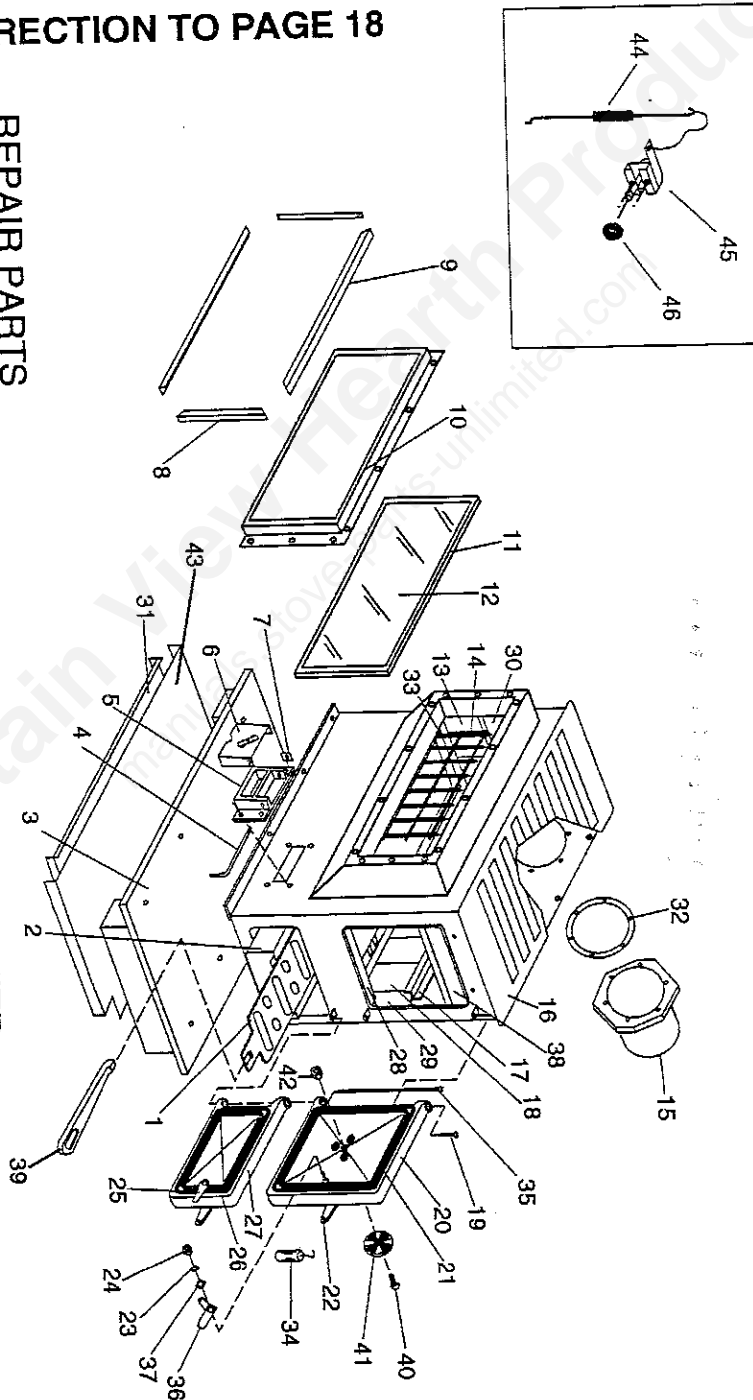

CORRECTION TO PAGE 19

REPAIR PARTS LIST- MODEL 2937 (SEE PAGE 18)

Key No.	Description	Qty.	Part No.
1	Coal Grate	1	40101
2	Ash Pan	1	68574
3	Base	1	67859
4	Draft Damper Hinge Pin	1	17200
5	Draft Damper Frame	1	40075
6	Draft Control Plate	1	68583
7	Clip spring	1	83818
8	Glass Brass Trim (LH/RH)	2	89382
9	Glass Brass Trim (TOP/BOTTOM)	2	89381
10	Glass Frame	1	68452
11	Glass Gasket	66*	88047
12	Glass (20 1/2"x12 1/2')	1	89409
13	Left Half Brick	1	23782
14	Front Coal Grate	1	40283
15	Flue Collar	1	40246
16	Fire Box Weldment	1	68910
17	Firebrick Retainer	1	40132
18	Firebrick	7	89066
19	Door Hinge Pin	1	83114
20	Feed Door	1	68605
21	Feed Door Rope Gasket	44*	88033
22	Door Handle	2	40091
23	Flat Washer	1	83045
24	Hex Nut (1/4-20)	2	83250
25	Latch	1	22108
26	Ash Door Rope Gasket	29*	88033
27	Ash Door	1	67781
28	Front Liner/ Rear Liner*	1	40100
29	Rear Half Brick	1	23785
30	Left Top Brick Retainer	1	23145
31	Second Heat Shield	1	22030
32	Flue Collar Gasket	1	88032
33	Air Wash Deflector	1	23547
*	Grate Support	2	22536
*	Grate Frame	1	40102
34	Wood Handle (Optional)	2	89523
35	Door Hinge Pin	1	23441
36	Two Step Latch	1	22434
37	Latch Spacer	1	21467
38	Smoke Curtain	1	22090
39	Shaker Handle	1	40045
40	Machine Screw (1/4-20x1)	1	83227
41	Draft Wheel	1	40056
42	Hex Nut (1/4-20)	1	83250
43	Heat Shield	1	22110
44	Thermostat Linkage Adjustment	1	86191
45	Thermostat	1	67743
46	Thermostat Knob	1	89687
*	NOT SHOWN		

REPAIR PARTS LIST- MODEL 2937 (SEE PAGE 18)

Key No.	Description	Qty.	Part No.
1	Coal Grate	1	40101
2	Ash Pan	1	68574
3	Base	1	67859
4	Draft Damper Hinge Pin	1	17200
5	Draft Damper Frame	1	40075
6	Draft Control Plate	1	68583
7	Clip	2	83818
8	Glass Brass Trim (LH/RH)	2	89382
9	Glass Brass Trim (TOP/BOTTOM)	2	89381
10	Glass Frame	1	68452
11	Glass Gasket	66*	88047
12	Glass (20 1/2"x12 1/2")	1	89409
13	Left Half Brick	1	23782
14	Front Coal Grate	1	40283
15	Flue Collar	1	40246
16	Fire Box Weldment	1	68693
17	Firebrick Retainer	1	40132
18	Firebrick	7	89066
19	Door Hinge Pin	1	83114
20	Feed Door	1	68605
21	Feed Door Rope Gasket	44*	88033
22	Thermostat	1	67743
23	Thermostat linkage adjustment	1	86191
24	Door Handle	2	40091
25	Flat Washer	1	83045
26	Hex Nut (1/4-20)	2	83250
27	Latch	1	22108
28	Ash Door Rope Gasket	29*	88033
29	Ash Door	1	67781
30	Thermostat Knob	1	89687
31	Front Liner	1	40100
32	Heat Shield	1	23703
33	Draft Damper	1	40282
34	Rear Half Brick	1	23785
35	Left Top Brick Retainer	1	23145
36	Second Heat Shield	1	22030
37	Flue Collar Gasket	1	88032
38	Air Wash Deflector	1	23547
*	Grate Support	2	22536
*	Corner Key (Brass Trim)	10	89419
*	Blank Key (Brass Trim)	10	89420
39	Wood Handle (Optional)	2	89523
40	Door Hinge Pin	1	23441
41	Two Step Latch	1	22434
42	Latch Spacer	1	21467
43	Smoke Curtain	1	22090
44	Top Liner	1	23474
45	Shaker Handle	1	40045
46	Machine Screw (1/4-20x1)	1	53227
47	Draft Wheel	1	40056
48	Hex Nut (1/4-20)	1	83250

* NOT SHOWN

HOW TO ORDER REPAIR PARTS

THIS MANUAL WILL HELP YOU TO OBTAIN EFFICIENT, DEPENDABLE SERVICE FROM THE HEATER, AND ENABLE YOU TO ORDER REPAIR PARTS CORRECTLY.

KEEP THIS MANUAL IN A SAFE PLACE FOR FUTURE REFERENCE.

WHEN WRITING, ALWAYS GIVE THE FULL MODEL NUMBER WHICH IS ON THE NAMEPLATE ATTACHED TO THE INSIDE OF THE CABINET DOOR OF THE HEATER.

WHEN ORDERING REPAIR PARTS OR OPTIONS, ALWAYS GIVE THE FOLLOWING INFORMATION AS SHOWN IN THIS LIST:

1. The PART NUMBER
2. The PART DESCRIPTION
3. The MODEL NUMBER: 2937
4. The SERIAL NUMBER: _____

BEFORE INSTALLING YOUR HEATER, FILL IN THE SERIAL NUMBER OF YOUR HEATER IN THE SPACE PROVIDED ABOVE.

United States Stove Company

227 Industrial Park Rd.
South Pittsburg, TN 37380
(615) 837-2100