

MODEL 45 DK DIRECT CONNECTION KIT FOR U.S. STOVE MODEL 4500 INSERT

This direct connection system is designed to direct the flue gases from the insert through the damper and smoke chamber to the bottom of the chimney flue as required by NFPA 211.

This system must be used in conjunction with a stainless steel straight oval flexible connector — not provided.

Connector Recommended Size

10.2" x 4.2" Oval x 4.75 Ft. Long

CAUTION:

Read All Instructions
Carefully Before Starting
The Installation

- Installation
- Operation
- Maintenance
- Repair Parts

SAVE THIS MANUAL FOR FUTURE REFERENCE

UNITED STATES STOVE COMPANY
3500 North Hawthorne Street — P.O. Box 5349
Chattanooga, Tennessee 37406 — (615) 698-3435

Inspection and Preparation of the Fireplace and Chimney

1. Thoroughly clean and inspect the chimney flue, smoke chamber for cracks, broken brick or mortar. Repair as necessary to bring chimney system into compliance with city or local building codes. — Remove the damper closing mechanism and the damper plate.

2. Carefully check the following:

— The damper frame must be a minimum of 4.5" wide to accommodate the flex connector.

— That a clear passageway exists between the damper frame and the bottom of the clay tiles in the chimney flue. (See Fig. 1)

3. Drill a 3/8" diameter hole in flex connector as shown in Fig. 2.

4. Push flex connector through damper frame and into the clay tile in the bottom of chimney flue. (Fig. 1)

5. If holes are not predrilled in top of 4500 insert, use boot connector for template to mark and drill holes (2) with drill bit provided in kit as shown in Fig. 3. If your insert has been predrilled at the factory, remove the self tapping screws, determine correct angle for boot placement: (Note: Boot is reversible to accommodate angle of flex connector into damper frame.) Place boot on insert top, make certain by-pass rod fits freely into slot in side of boot. Tighten boot in place with screws provided in kit. (See Fig. 4)

6. Slide insert into proper position in fireplace, slip flex connector into hole in boot, align holes in connector with holes in end of boot and slide the rod through both holes. (Fig. 4)

7. Install front surround on 4500 insert, make certain a good seal is maintained around perimeter of insert where it meets the fireplace front.

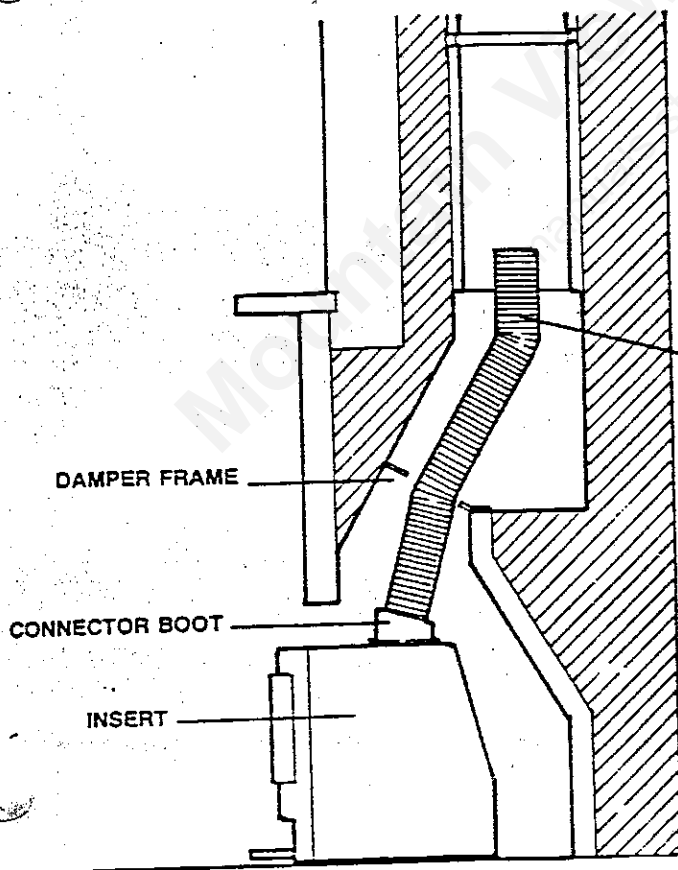

FIG. 1

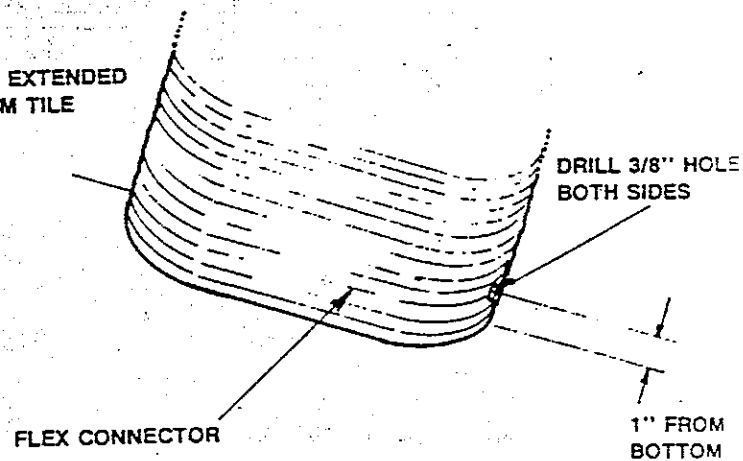

FIG. 2

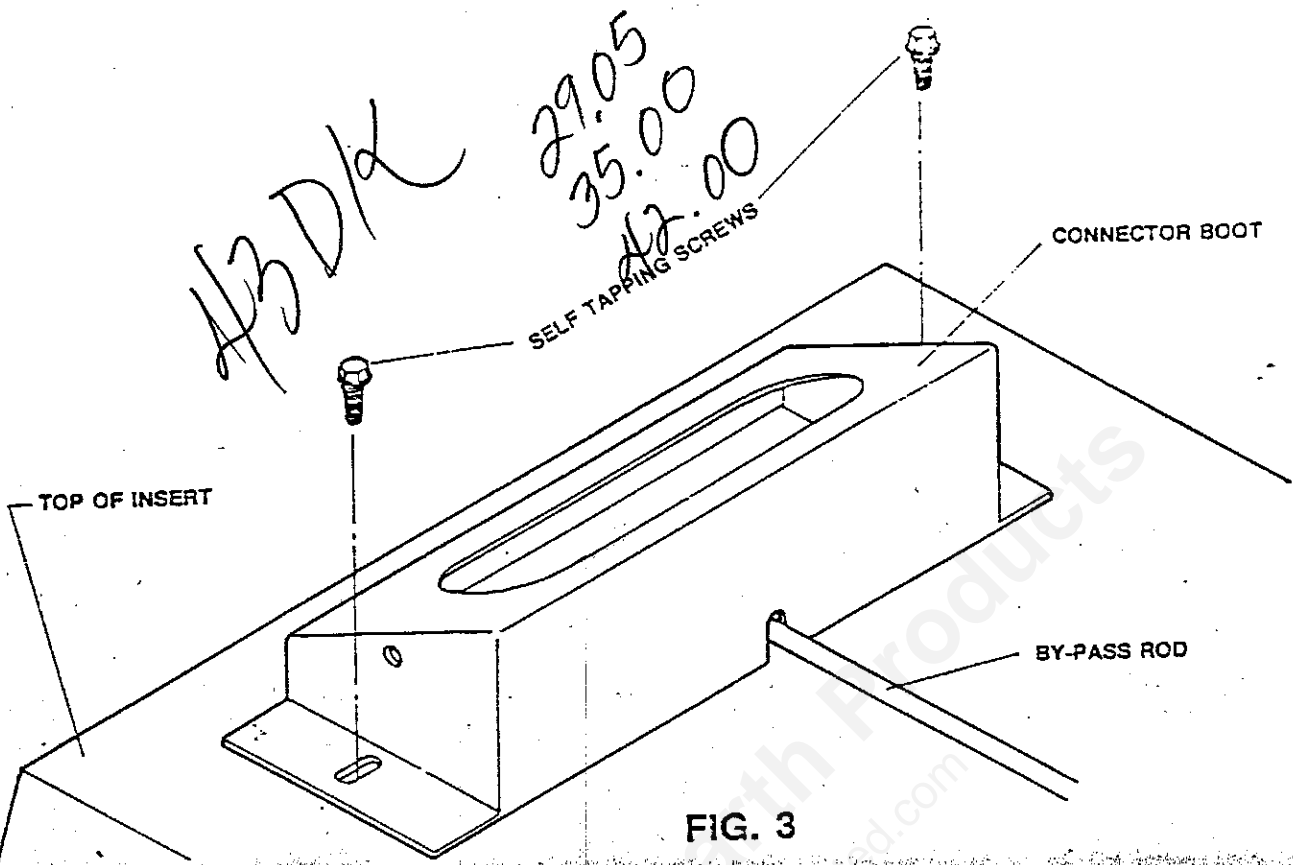

FIG. 3

1 Section
 Stainless Steel Flex Pipe

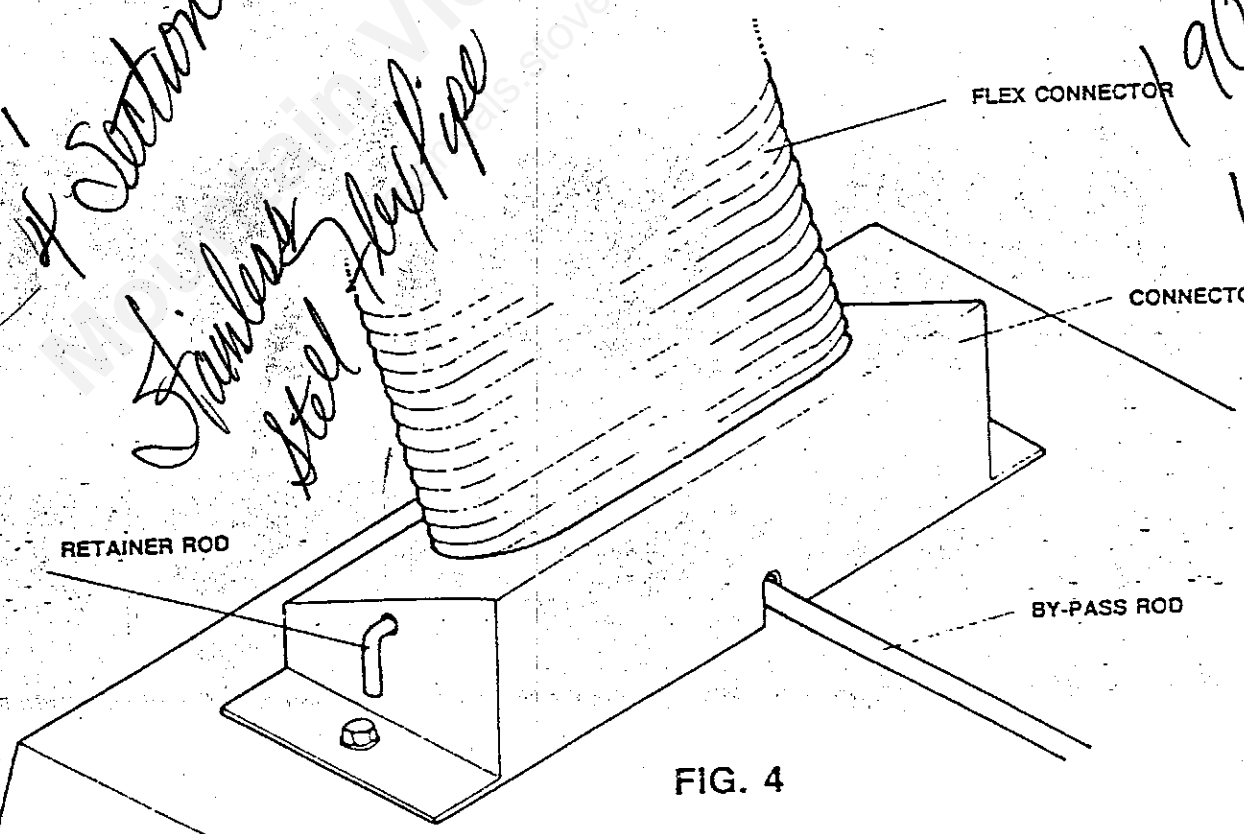

FIG. 4