



# 6" to 8" Ceiling Heat Shield

## Installation Instructions for use on Defiant Woodburning Stoves

**WARNING:** The cut edges of sheet metal are very sharp. Always wear heavy leather work gloves when working with sheet metal. Always wear protective eyewear.

### Kit contents:

- 1, 6" to 8" Heat Shield
- 4, 1" Spacers
- 4, 2½" Screws

**Tools required:** #1 and #2 Phillips screwdrivers, pliers, gloves, safety goggles.

### Installation Instructions

Before beginning the final connection of the stovepipe, place the heat shield over the pipe with the unpainted surface toward the ceiling. Slide the heat shield up to the ceiling placing one (1) 1" spacer between the ceiling and the screw hole in the heat shield. Install a screw through the spacer into the ceiling. Repeat for the remaining holes and spacers. *Figure 1*

Modify the heat shield for 8" diameter stovepipe by holding the heat shield with one hand and use pliers to break the four (4) connection points between the 6" diameter ring and the heat shield. *Figure 2*

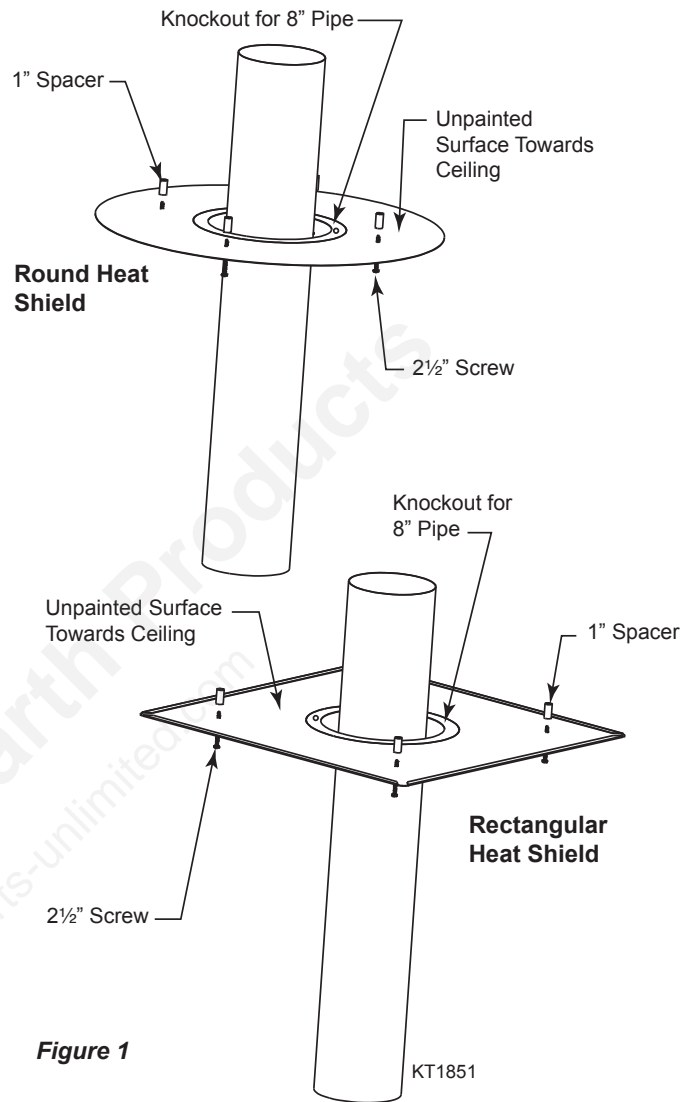

Figure 1

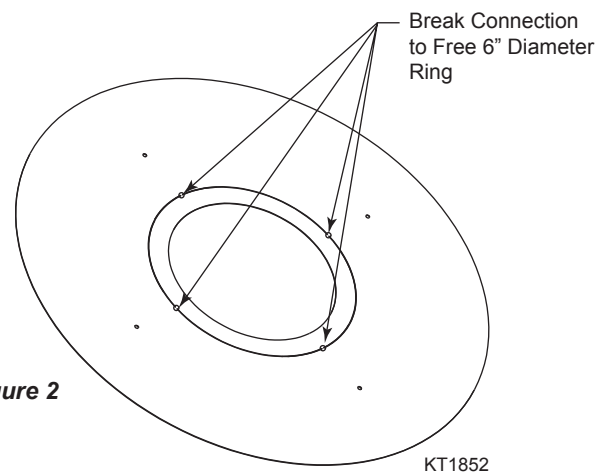

Figure 2

### Vermont Castings Group

149 Cleveland Drive • Paris, Kentucky 40361  
www.vermontcastingsgroup.com