



Fireback Kit #5925

Installation Instructions
for use on

Defiant Encore Models 0028, 2140

Please read these instructions before beginning the repair procedure.

General Information

The Model 5925 Defiant Encore Fireback is for use with the models 0028 and 2140 Defiant Encore stoves, built between 1986 and December 1991. These stoves are distinguishable by having a cast iron plate bolted to the outer back of the stove for access to the catalytic combustor. Some of these stoves also have the '1986' date cast on the lower fireback, visible through the front doors.

Material provided:

- (1) Upper fireback and damper assembly
- (1) Lower fireback
- (1) Stainless steel 'heat exchanger'
- (1) Secondary probe assembly
- (6) Kaowool strips
- (1) Tube of stove cement
- (1) Refractory (insulating) assembly
- (6) 1/4"-20 x 1" hex head bolts
- (6) 1/4" washers
- (1) 5/16" x 24" fiberglass gasket
- (1) 5/32" Allen wrench

Tools required:

| | |
|--------------------------|-----------------------------|
| Phillips screwdriver | Standard (flat) screwdriver |
| Putty knife | Cold chisel |
| 7/16" hex ratchet wrench | Dust mask |
| Goggles | 3/16" Allen wrench |
| 3/16" Drill bit | Wire brush |

Before starting the repair procedure, be sure the stove is cold. Note that ashes and embers can stay hot for a long time; remove all ashes and embers and store them properly in a sealed metal container on a noncombustible surface away from all nearby combustibles. The empty ashpan will be a handy storage spot for hardware, tools and small parts.

Work in a clean, well-lighted area. Protect your work area with tarps or drop cloths. Protect yourself with goggles and dust mask.

In these instructions, 'right' and 'left' are given as you face the stove.

Disassembly Procedure

1. Remove the griddle and the front doors. Lift each door until the bottom hinge pin clears the bottom hinge hole. Swing the bottom of the door away from the stove and lower it so the top hinge pin clears the top hinge hole. Set the doors face down on a padded surface.
2. Unbolt the andirons from lower front panel of the stove, and set aside. Lift out the grate and set aside.
3. At the top of the left inner wall of the stove, there is an access panel for the damper linkage. This panel is bolted and cemented into place. You may need to wire-brush the area to find the countersunk Allen bolts holding the panel in place. Remove the bolts with a 3/16" Allen wrench, and remove the panel. You may need to use a cold chisel or old screwdriver to remove the original cement.
4. Use the damper handle to put the damper in the open position. Use the 5/32" Allen wrench to remove the damper handle stub.
5. Reach inside the damper linkage access opening. While holding the damper activating link (Fig. 3, Item 19) with one hand, pull the damper handle rod (Fig. 3, Item 18) from the hole in the left side of the stove and from the forward hole in the link with the other hand. Be sure to hold onto the activating link and the 3/8" flat washer. These will be nearly impossible to retrieve if dropped.
6. Use the activating link to pull the damper toward the closed position and disengage the back end of the link from the damper torsion bar (Fig. 3, Item 11). Release the torsion bar gently to avoid letting the damper drop onto the steel shield on the catalyst refractory housing.
7. Remove the four (4) bolts holding the upper fireback assembly (Fig. 3, Item 10) in place. Remove the assembly. You may need to pry it loose, since there is stove cement on the top back edge.
8. Remove the two (2) bolts holding the lower fireback (Fig. 3, Item 14) in place, and remove the fireback.
9. If there is an external back heat shield on the stove, remove it by unthreading the four (4) truss-head screws holding it to the spacers.
10. Remove the cast iron catalyst access panel (Fig. 3, Item 1) from the back of the stove by removing four (4) bolts.
11. Remove the refractory catalyst access panel (Fig. 3, Item 2) from the stove. It is friction fit into place. Rock it out gently.

12. Remove the catalyst (Fig. 3, Item 3) from the chamber by sliding it out through the opening in the back of the stove. Handle it gently, it is fragile. Inspect it for excessive wear, crumbling, plugging, etc., according to the instructions in the Encore Owner's Guide. Replace it if necessary.

13. Remove the steel secondary probe thermostat cover (Fig. 3, Item 25) from the back of the stove by removing two (2) phillips head bolts.

14. Disengage the slender connecting link from the end of the secondary thermostat (Fig. 3, Item 24). Leave it attached to the pivoting valve plate. Remove the secondary thermostat by unthreading the bolt which holds it in place and sliding the thermostat out toward the front.

15. Inside the firebox, remove the stainless steel refractory cover (Fig. 3, Item 6)

16. Remove the refractory chamber and the stainless steel heat exchanger (Fig. 3, Items 7, 21) together as a unit.

17. Remove the stainless steel left and right heat deflectors (Fig. 3, Items 8, 22) from the stove back.

18. Remove and discard the four (4) Kaowool strips (Fig. 3, Item 5) from the stove back.

19. Use a hammer and cold chisel to remove any remaining stove cement from the rear edges of the left and right inner stove walls (Fig. 3, Items 9, 15) and from the groove in the underside of the stove top, where the top edge of the upper fireback assembly mates to the stove top. Remove any remaining stove cement from the damper link access panel and the left inner side. (Fig. 3, Items 20, 15) Remove any cement or ashes from the groove in the stove bottom where the bottom edge of the lower fireback fits.

Re-Assembly Procedure

1. Cut four (4) new Kaowool strips to a 5" length and install in the bottom of the stove back by setting in place.

2. Remove the refractory catalyst access panel (Fig. 3, Item 2) from the back of the new refractory chamber supplied in this kit. The access panel is friction fit into the main chamber body. You may need to run a sharp knife around the edge of the access panel to loosen it from the chamber.

3. Put the upper edge of the stainless steel heat exchanger (Fig. 3, Item 21) into the opening on the front of the refractory chamber. There are two main openings on the chamber, the one from which the access panel was removed in Step 2 is on the back of the chamber. Let the bottom of the chamber sit on the bottom of the heat exchanger. Put this assembly into the stove back as a unit.

4. Install the left and right heat deflectors (Fig. 3, Items 8, 22) at the sides of the refractory chamber. Notice their

positioning; the longer legs of the 'L' shape go against the outer walls of the stove back away from the refractory. These deflectors protect the cast iron outer back from very high temperature gases leaving the catalyst chamber.

5. Slip the stainless steel refractory cover (Fig. 3, Item 6) onto the top of the refractory chamber.

6. ~~Apply a bead of stove cement to the back left and right edges of the new lower fireback (Fig. 3, Item 14).~~ Apply a length of 5/16" rope gasket on the ends of the fireback as shown in Figure 1. Press-fit the remaining two (2) Kaowool strips on the back of the fireback. (Fig. 1) Apply cement in the groove in the stove bottom where the bottom edge of the lower fireback fits. Set the lower fireback in place in the stove, and fasten it with two (2) new bolts and washers from this kit. Since parts may have moved or expanded over time, you may need to enlarge the holes in the fireback to be able to mate them to the bolt holes in the inner walls of the stove.

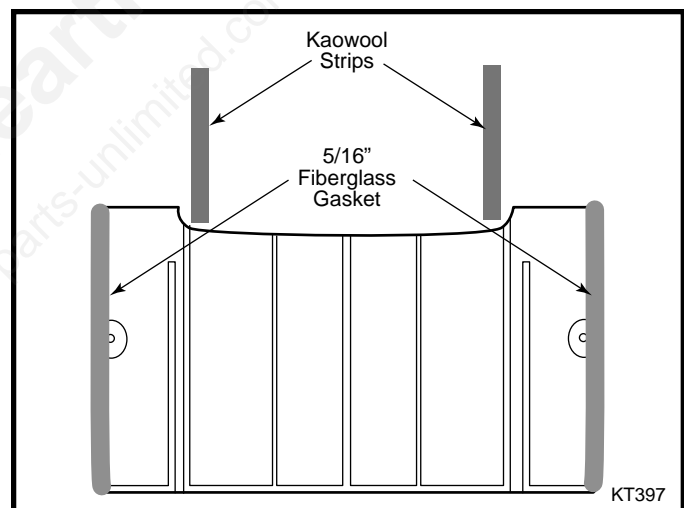

Fig. 1 Back view of lower fireback.
Apply 5/16" gasket to the rear of the upper fireback assembly.

7. ~~Apply a bead of stove cement to the back left and right edges of the new upper fireback assembly (Fig. 3, Item 10),~~ lift it into position in the stove and fasten it with four (4) new bolts and washers from this kit. Be sure the torsion bar passes through the access opening at the top of the left inner stove side.

8. Test the damper action by making sure it can move freely. Be careful to not let it drop sharply onto the steel cover on the refractory chamber.

9. Reinstall the damper activating link (Fig. 3, Item 19). This piece looks like a hockey stick. There is only one way to install this link so that it will close and lock the damper properly. The blade of the hockey stick must be toward the front of the stove and must aim downward.

Hold onto the activating link and arm securely; it will be extremely difficult to retrieve if they fall into the space between the inner and outer stove walls.

Install the back end first by sliding it onto the end of the damper torsion bar. Slide it onto the short end of the J-shaped activating arm (Fig. 3, Item 18). Pass the other end of the activating arm through the hole in the left side of the stove and attach the damper handle (Fig. 3, Item 17). Notice the Allen bolt (Fig. 3, Item 16) must tighten against a flat area on the activating arm. Be sure to slide the handle fully onto the arm; then secure it with the Allen bolt. Test the damper system to ensure parts are aligned properly.

10. Reinstall the damper link access panel (Fig. 3, Item 20) by applying a bead of cement to the edges and bolting it into place with a 3/16" Allen wrench.

11. Hand turn a 3/16" drill bit through the hole in the back of the stove for the secondary probe thermometer. Install the thermometer by sliding it through the hole and fasten in place with a Phillips head screw. When positioned properly, the tab at the end of the secondary coil will be in the 4- to 5-o'clock range (when looking at the back of the stove). (Fig. 2)

12. Connect the slender steel link between the secondary thermometer coil and the secondary air valve (shown in Figure 2 and Fig. 3, Item 23). Make sure the valve can pivot freely on the bolt.

13. Replace the secondary thermostat cover (Fig. 3, Item 25).

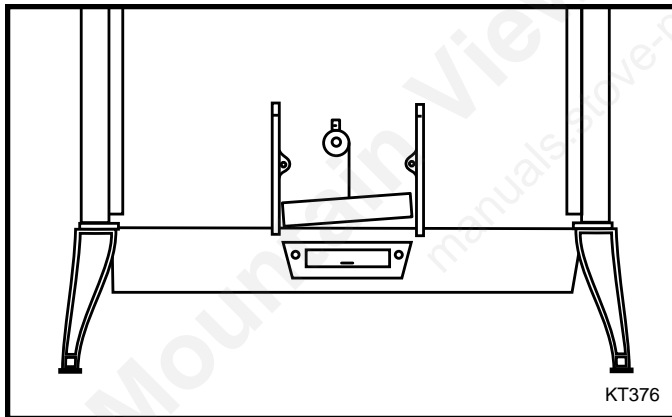

Fig. 2 Rear view of stove.

14. Slide the catalyst into the back of the stove through the access hole in the stove back. The open ends of the 'honeycomb' must be on the top and bottom surfaces of the catalyst. The lower forward edge of the catalyst sits on a ridge which is part of the stainless steel heat exchanger (Fig. 3, Item 21). Be sure the catalyst is fully into the refractory chamber.

15. Install the new refractory access panel (Fig. 3, Item 2) through the opening in the back of the stove. It is friction fit into position. Be sure the outer surface is flush with the outer surface of the refractory chamber (Fig. 3, Item 7)

16. Reinstall the cast iron catalyst access panel (fig. 3, Item 1) by securing it with four (4) phillips bolts. If the stove has a steel rear heat shield, reinstall it by attaching it to the spacers with four (4) phillips head bolts.

17. Reinstall the andirons by bolting them to the lower edge of the stove front.

18. Reinstall the grate (Fig. 3, Item 13) by putting it gently into place. Notice the narrower sides of the slots face upward, toward the firebox.

19. Reinstall the front doors. Be careful with them, especially if they are enamelled. Lift the doors, one at a time, and slide the upper hinge pin fully into the hole in the stove front. Bring the bottom edge of the door toward the stove front and position it so the bottom hinge pin will engage the lower hinge pin hole. Make sure the door seats fully downward.

20. Put the griddle in place.

21. Let the stove cement dry for 24 hours.

22. Send the original refractory chamber, heat exchanger, and firebacks to your local solid waste disposal agency. The refractory chamber is ceramic fiber; it will not burn.

23. When you refire the stove, you must 'cure' the new cast iron. Just as you did when the stove was new. This acclimates the iron to the stresses of heating and cooling. Build six (6) small fires, each 100°F hotter and an hour longer than the previous one. Let the stove cool to room temperature before you build the next fire. When you have consistently reached stove-top temperatures of 600°F, you can resume normal firing.

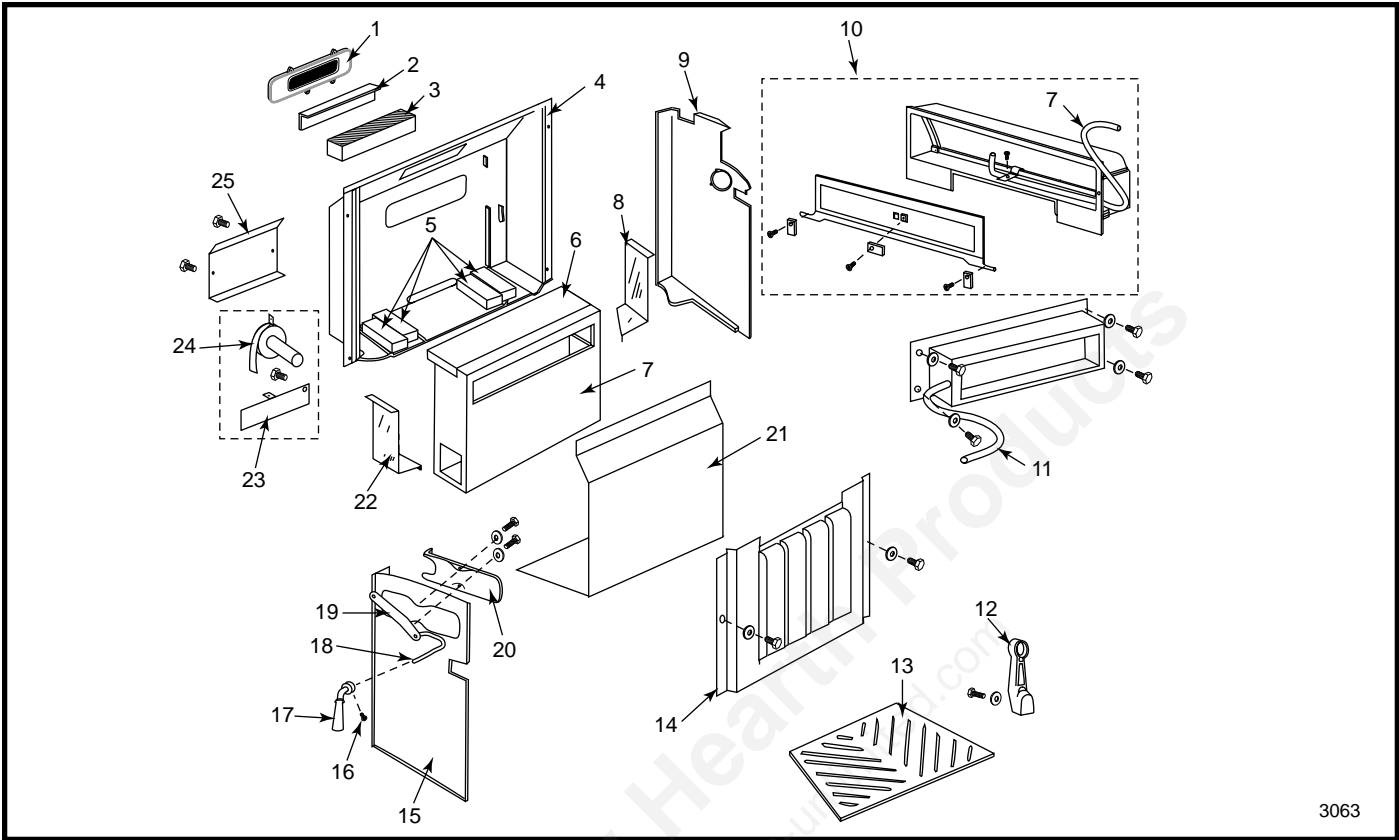

3063

Fig. 6 Firebox parts diagram, Models 0028 and 2140 Defiant Encore stove.

- | | |
|---------------------------------------|---------------------------------------|
| 1. Catalyst access panel (iron) | 13. Grate |
| 2. Catalyst access panel (refractory) | 14. Lower fireback* |
| 3. Catalyst | 15. Left inner side |
| 4. Outer back | 16. Handle Allen bolt |
| 5. Kaowool strips (4) | 17. Damper handle |
| 6. Refractory cover (stainless steel) | 18. Damper activating arm |
| 7. Refractory chamber* | 19. Damper activating link |
| 8. Right heat deflector | 20. Damper link access panel |
| 9. Right inner side | 21. Heat exchanger (stainless steel)* |
| 10. Upper fireback assembly* | 22. Left heat deflector |
| 11. Damper torsion bar* | 23. Secondary thermostat valve |
| 12. Andiron (2) | 24. Secondary probe thermostat* |
| | 25. Secondary thermostat cover |
- * Included in the #5925 kit.

CFM Specialty Home Products reserves the right to make changes in design, materials, specifications, prices and discontinue colors and products at any time, without notice.

CFM Specialty Home Products

410 Admiral Blvd. • Mississauga, Ontario, Canada L5T 2N6 • 905-670-7777
 www.majesticproducts.com • www.vermontcastings.com