

Defiant Woodburning Stove

Model 1945

Homeowner's Installation and Operating Manual

For use in the
United States and Canada

SAFETY NOTICE: IF THIS APPLIANCE IS NOT PROPERLY INSTALLED, OPERATED AND MAINTAINED, A HOUSE FIRE MAY RESULT. TO REDUCE THE RISK OF FIRE, FOLLOW THE INSTALLATION INSTRUCTIONS. FAILURE TO FOLLOW INSTRUCTIONS MAY RESULT IN PROPERTY DAMAGE, BODILY INJURY OR EVEN DEATH. CONTACT LOCAL BUILDING OFFICIALS ABOUT RESTRICTIONS AND INSTALLATION INSPECTION REQUIREMENTS IN YOUR AREA.



We recommend that our woodburning hearth products be installed and serviced by professionals who are certified in the U.S. by the National Fireplace Institute® (NFI) as NFI Woodburning Specialists or who are certified in Canada by Wood Energy Technical Training (WETT).



Do Not Discard This Manual: Retain for Future Use

30001693 7/08 Rev. 24

Welcome

Congratulations on your choice of a Vermont Castings Defiant stove. With this purchase you have made a commitment to make the hearth a place of warmth, beauty and comfort in your home. At MHSC, we share that joy and appreciation for the hearth. We assure you that your cast-iron Vermont Castings stove has been made with the utmost care and will provide you with many years of service.

As you become acquainted with your new stove, you will find that its appearance is matched by its functionality, due to cast iron's unique ability to absorb and radiate heat.

Also, MHSC products are among the cleanest-burning wood stoves and fireplaces available today. As an owner of a Vermont Castings stove, you make a strong statement for pollution-free energy. However, clean burning depends on both the manufacturer and the operator. Please read this manual carefully to understand how to properly operate and maintain your stove.

At MHSC, we are equally committed to your satisfaction as a customer. That is why we maintain an exclusive network of the finest dealers in the industry. Our dealers are chosen for their expertise and dedication to customer service. They are factory-trained and knowledgeable about every MHSC product. Feel free to contact your Authorized Vermont Castings Dealer anytime you have a particular question about your stove or its performance.

This manual contains valuable instructions on the installation and operation of your Vermont Castings Defiant. It also contains useful information on maintenance. Please read the manual thoroughly and keep it as a reference.

Sincerely,

All of Us at MHSC

This manual describes the installation, operation, and maintenance of the Vermont Castings Defiant Model 1945 catalytic-equipped wood burning heater. This heater meets the U.S. Environmental Protection Agency's emission limits for wood heaters sold on or after July 1, 1990. Under specific test conditions this heater has been shown to deliver heat at rates ranging from 10,600 to 55,000 Btu/hr.

The Defiant Model #1945 has been tested and is listed by Canadian Standards Association (CSA). The test standards are ANSI/UL-1482 and ANSI/UL-737 for the United States, and ULC S627 and CAN/CSA-B366.2 for Canada. The Defiant is listed for burning wood only. Do not burn other fuels. The Defiant is approved for use in manufactured (mobile) homes only in the United States, and only when installed with Vermont Castings Mobile Home Kit No. 1900.

Installation or service of this woodburning stove should only be completed by a qualified installer, preferably NFI or WETT (Canada) certified.

Please read this entire manual before you install and use your new stove. Failure to follow instructions may result in property damage, bodily injury, or even death.

Save These Instructions for Future Reference

The Story of the Defiant

No wood-burning appliance, save for Ben Franklin's Pennsylvania Fireplace, has a stronger heritage than the Vermont Castings Defiant. Named for a 19th-century steamship, the original Vermont Castings Defiant Wood Stove came to epitomize America's resolve and independence during the Energy Crisis of the 1970s.

The year was 1975. With energy prices going through the roof, and not an attractive or efficient wood stove to be found anywhere, two entrepreneurs set out to create a stove that was a thing of beauty as well as utility. Finely crafted from cast iron, the Defiant was the first wood stove to combine an artistically designed exterior with a methodically engineered interior, using new technologies for efficient combustion.

Americans purchased over a quarter-million Defiants, as they rediscovered the common sense of heating with wood, a home-grown fuel with none of the political and economic entanglements of foreign oil.

Thirteen years later, in 1988, Vermont Castings 'retired' the Defiant, replacing it with modern wood-burners such as the Encore.

With its 1998 return, the new Defiant incorporates all the finest aesthetic, convenience, and performance features to be found on any wood stove. In a sense, the new Defiant has been 23 years in the making.

Due to its significant role in American history, the original model Defiant is in the permanent collection of the Smithsonian Institution. Each new purchase of the Defiant stove continues that history.

Table of Contents	
Specifications	4
Installation	5
Clearance Charts	14
Assembly	18
Operation.....	19
Maintenance	29
Appendix: Catalytic Combustor	35
Appendix:	
Chimney & Fireplace Hazards	36
Parts Diagram	37

Proposition 65 Warning: Fuels used in gas, wood-burning or oil fired appliances, and the products of combustion of such fuels, contain chemicals known to the State of California to cause cancer, birth defects and other reproductive harm.
California Health & Safety Code Sec. 25249.6

Installation Accessories	
Warming Shelf	
#1560 Classic	#1562 Sand
#1555 Biscuit	#1565 Bordeaux
#1556 Chestnut Brown	#1566 Forest Green
#1557 Ebony	#1567 Midnight Blue
#1558 Vt. Classic Green	#1568 Suede Brown
#1900 Mobile Home Kit	
#1904 Outside Air Adapter	
#1905 Bottom Heat Shield Kit	
#1901 Rear Heat Shield Kit	
#1907 Firescreen	
#1860 6" x 12" Oval Starter Pipe	
A line of porcelain enamel stove pipe is also available.	

Specifications

Defiant, Model 1945

EPA Emissions rating 8 GPH*
 Range of heat output 10,600 to 44,400 Btu's/hr.*
 Maximum heat output 55,000 Btu's/hr.**
 Area heated Up to 2,400 Square feet***
 Fuel Size/type 22 - 24" hardwood
 Fuel capacity 50 pounds
 Loading Front or top
 Chimney Connector:
 for 8" flue collar 8" (200 mm) diameter
 Chimney Flue Size:
 with 8" Chimney Connector..8" (200 mm) minimum
 with 6" Chimney Connector..6" (150 mm) minimum
 Flue exit position Top or Rear
 Primary Air ... Manually set, thermostatically maintained
 Secondary Air Self-regulating
 Ash handling system Removable ash pan
 Glass panels High-temperature ceramic
 Weight 480 lbs. (220 kg.)
 Width (leg to leg) 33" (826 mm)
 Depth (leg to leg) 19½" (362 mm)
 Height to top of flue collar 30½" (775 mm)

*Under specific conditions during EPA emissions testing.

** This value can vary depending on how the stove is operated, the type and moisture content of the fuel used, as well as the design, construction and climatic location of your home. Figures shown are based on maximum fuel consumption obtained under laboratory conditions and on average efficiencies.

*** These values are based on operation in building code-conforming homes under typical winter climate conditions in New England. If your home is of nonstandard construction (e.g. unusually well insulated, not insulated, built underground, etc.) or if you live in a more severe or more temperate climate, these figures may not apply. Since so many variables affect performance consult your Authorized Dealer to determine realistic expectations for your home.

U.S. and foreign design and mechanical patents pending.

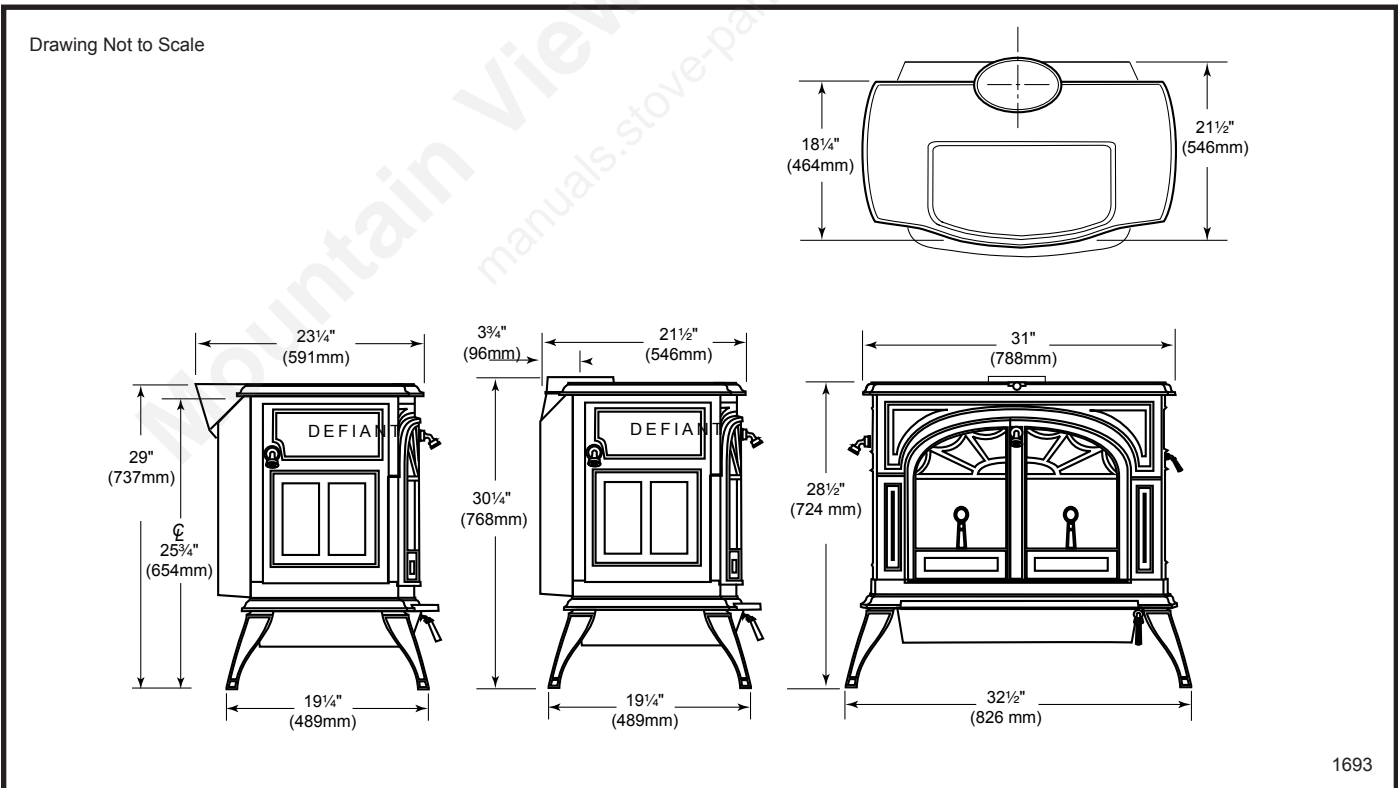

Fig. 1 Defiant dimensions.

Installation

SAFETY NOTICE: IF YOUR DEFIANT IS NOT PROPERLY INSTALLED, A HOUSE FIRE MAY RESULT. TO REDUCE THE RISK OF FIRE, FOLLOW THE INSTALLATION INSTRUCTIONS. CONTACT LOCAL BUILDING OR FIRE OFFICIALS ABOUT RESTRICTIONS AND INSTALLATION INSPECTION REQUIREMENTS IN YOUR AREA.

Before you begin an installation, be sure that:

- Your stove and chimney connector will be far enough from combustible material to meet all clearance requirements.
- The floor protector is large enough and is constructed properly to meet all requirements.
- You have all necessary permits from local authorities.

Your local building official is the final authority for approving your installation as safe and determining that it meets local and state codes.

The metal label permanently attached to the back of every Vermont Castings' stove indicates that the stove has been tested to current UL and ULC standards, and gives the name of the testing laboratory. Clearance and installation information also is printed on the label. When the stove is installed according to the information both on the label and in this manual, local authorities usually will accept the label as evidence that the installation meets codes and can be approved.

However, codes vary in different areas. Before starting the installation, review your plans with the local building authority. Your local dealer can provide any additional information needed.

For any unresolved installation issues, refer to the National Fire Protection Association's publication ANSI/NFPA 211 Standard for Chimneys, Fireplaces, Vents and Solid Fuel Burning Appliances. For Canada, the equivalent publication is CSA CAN-B365 Installation Code for Solid Fuel Burning Appliances and Equipment. These standards are the basis for many national codes. They are nationally recognized and are accepted by most local authorities. Your local dealer or your local building official may have a copy of these regulations.

IMPORTANT: Failure to follow these installation instructions may result in a dangerous situation, including a chimney or house fire. Follow all instructions exactly, and do not allow makeshift compromises to endanger property and personal safety.

Outside Air

In some modern, super-insulated homes, there is inadequate air supply for combustion because of insufficient air infiltration into the building. Such air enters a home through unsealed cracks and openings. Exhaust fans for kitchen or bath can compete with the stove for available air and compound the problem.

When poor draft is caused by a low infiltration rate, opening a ground floor window on the windward side of the house and near the stove will usually alleviate the problem.

A better solution is to install a permanent outside air supply to the stove and/or room. In fact, bringing air for combustion from outside the home directly to the air inlet of the stove is required for new construction in some areas.

Pressure variations within the house do not affect a stove equipped with an outside air supply, and improved stove performance often results. An Outside Air Adapter Kit for the Defiant is available from your local dealer.

Chimney Height

Altitude affects chimney performance. When using an 8" oval to 6" flue collar adapter on the Defiant, refer to Figure 1 for suggested chimney heights at various altitudes. Chimney height should be measured from the flue collar to the top of the chimney. The recommended minimum chimney height is 16 feet (5 meters).



Fig. 2 Chimney height requirements with 6" chimney and/or chimney connector.

What Kind of Chimney to Use

You must connect the Defiant to a code-approved masonry chimney with a flue liner, to a relined masonry chimney that meets local codes, or to a prefabricated metal chimney that complies with the requirements for Type HT chimneys in the Standard for Chimneys, Factory-Built, Residential Type and Building Heating Appliance, UL 103. Figure 3 illustrates the two types. The chimney and chimney connector must be in good condition and kept clean.

If you use an existing masonry chimney, it must be inspected to ensure it is in a safe condition before the stove is installed. Your local professional chimney sweep, building inspector, or fire department official will be able to inspect the chimney or provide a referral to someone who can. See "Chimney and Fireplace Hazards", in the appendix, for particulars.

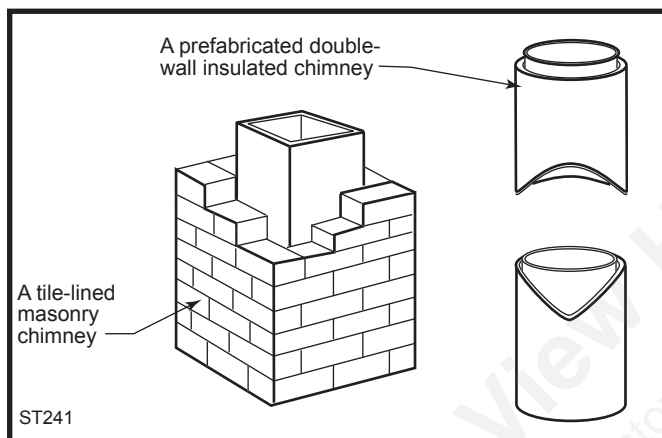

Fig. 3 Approved chimney types.

The chimney must extend at least 3' (194 mm) above the highest point where it passes through or past a roof, and at least 3' (610 mm) higher than any part of a building within 10' (3 m) horizontally. (Fig. 4)

For proper draft and good performance, any chimney used with a Defiant should extend at least 16' (5 m) above the flue collar of the stove.

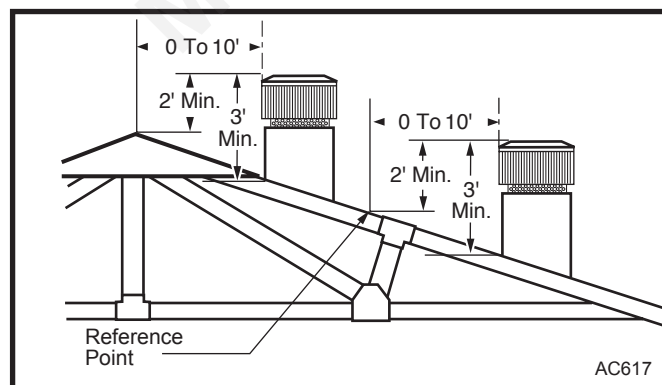

Fig. 4 The 2'-3'-10' Chimney Rule.

Masonry Chimneys

An inspection of the chimney must confirm that it has a lining. Do not use an unlined chimney. The chimney should have no cracks, loose mortar, other signs of deterioration, and blockage. Repair any defects before the chimney is used with your stove.

Unused openings in an existing masonry chimney must be sealed with masonry to the thickness of the chimney wall, and the chimney liner should be repaired. Openings sealed with pie plates or wallpaper are a hazard and should be sealed with mortar or refractory cement. In the event of a chimney fire, flames and smoke may be forced out of these unused thimbles.

The chimney should be thoroughly cleaned before use.

A newly-built masonry chimney must conform to the standards of your local building code or, in the absence of a local code, to a recognized national code. Masonry chimneys must be lined, either with code-approved masonry or pre-cast refractory tiles, stainless steel pipe, or a code-approved, "poured-in-place" liner. The chimney's clean-out door must seal tightly. A loose or leaky clean-out door can weaken chimney draft to the stove, causing performance problems.

Prefabricated Chimneys

A prefabricated metal chimney must be one tested and listed for use with solid-fuel burning appliances to the High-Temperature (H.T.) Chimney Standard UL-103-1985 (2100°F) for the United States, and High Temperature (650°C) Standard ULC S-629 for Canada.

DO NOT CONNECT THIS UNIT TO A CHIMNEY FLUE SERVING ANOTHER APPLIANCE.

Chimney Size

An Defiant with an 8" (203 mm) flue collar is approved for venting into a masonry chimney with a nominal flue size of 8" x 8" (203 x 203 mm) or 8" x 12" (203 x 305 mm), and into a round flue with nominal flue size of 8" (203 mm). An Defiant with a 6" (152 mm) flue collar is approved for venting into a masonry chimney with a nominal flue size of 8" x 8" (203 x 203 mm), and into a round flue with nominal flue of 6" (152 mm).

NOTE: When installed with a 6" flue collar, the Defiant may not be operated with the front doors open.

Whatever the flue collar size, an Defiant may be vented into larger chimneys as well. However, chimneys with liners larger than 8" x 12" (203 x 305 mm) may experience rapid cooling of smoke and reduction in draft, especially if the chimneys are located outside the home. These large chimneys may need to be insulated or have their flues relined for proper stove performance.

Accessories to help make the connection between stainless steel chimney liners and your Defiant are available through your local dealer.

Chimney Connector Guidelines

A chimney connector is the single-wall pipe that connects the stove to the chimney. The chimney itself is the masonry or prefabricated structure that encloses the flue. Chimney connectors are used only to connect the stove to the chimney.

Single-wall connectors should be made of 24 gauge or heavier steel. Do not use galvanized connector; it cannot withstand the high temperatures that can be reached by smoke and exhaust gases, and may release toxic fumes under high heat. The connector may be 6" (152 mm) or 8" (203 mm) in diameter.

If possible, do not pass the chimney connector through a combustible wall or ceiling. If passage through a combustible wall is unavoidable, refer to the section on Wall Pass-Throughs. Do not pass the connector through an attic, a closet or similar concealed space. The whole connector should be exposed and accessible for inspection and cleaning.

In horizontal runs of chimney connector, maintain a distance of 24" (610 mm) from the ceiling. Keep it as short and direct as possible, with no more than two 90° turns. Slope horizontal runs of connector upward 1/4" per foot (6mm per meter) going from the stove toward the chimney. The recommended maximum length of a horizontal run is 3' (1 m), and the total length should be no longer than 8' (2.4 m). In cathedral ceiling installations, extend the prefabricated chimney downward to within 8' (2.4 m) of the stove. This will help maintain a good draft by keeping the smoke warm, so that it rises readily.

Wear gloves and protective eyewear when drilling, cutting or joining sections of chimney connector.

Single-wall Chimney Connectors

- Begin assembly at the flue collar of the stove. Insert the first crimped end into the stove's flue collar, and keep each crimped end pointing toward the stove. (Fig. 5) Using the holes in the flue collar as guides, drill 1/8" (3mm) holes in the bottom of the first section of chimney connector and secure it to the flue collar with three #10 x 1/2" sheet metal screws. Lift off the griddle, and shield the stove's surface between the griddle opening and the front of the flue collar to protect the finish when you drill the front hole.
- Fasten each joint between sections of chimney connector, including telescoping joints, with at least three (3) sheet metal screws. The pre-drilled holes in the top of each section of chimney connector serve as guides when you drill 1/8" (3mm) holes in the bottom of the next section.

- Fasten the chimney connector to the chimney. Instructions for various installations follow. Figure 5 illustrates the general layout of chimney connector parts.
- Be sure the installed stove and chimney connector are correct distances from nearby combustible materials.

NOTE: Special slip pipes and thimble sleeves that form telescoping joints between sections of chimney connector are available to simplify installations. They often eliminate the need to cut individual connector sections. Consult your local dealer about these special pieces.

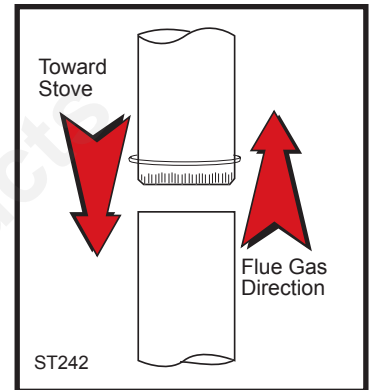

Fig. 5 Chimney connector.

Securing the Single-wall Connector to a Prefabricated Chimney

Follow the installation instructions of the chimney manufacturer exactly as you install the chimney. The manufacturer of the chimney will supply the accessories to support the chimney, either from the roof of the house, at the ceiling of the room where the stove is installed, or from an exterior wall.

Special adapters are available from your local dealer to make the connection between the prefabricated chimney and the chimney connector. The top of such adapters attaches directly to the chimney or to the chimney's ceiling support package, while the bottom of the adapter is screwed to the chimney connector.

These adapters are designed so the top end will fit outside the inner wall of the chimney, and the bottom end will fit inside the first section of chimney connector.

Securing the Single-wall Connector to a Masonry Chimney

Both freestanding masonry chimneys and fireplace masonry chimneys may be used for your installation.

Freestanding Installations

If the chimney connector must pass through a combustible wall to reach the chimney, follow the recommendations in the Wall Pass-Through section that follows. The opening through the chimney wall to the flue (the "breach") must be lined with either a ceramic or metal cylinder, called the "thimble", which is cemented securely in place. Most chimney breeches incorporate thimbles, but the fit must be snug and the joint between the thimble and the chimney wall must be cemented firmly.

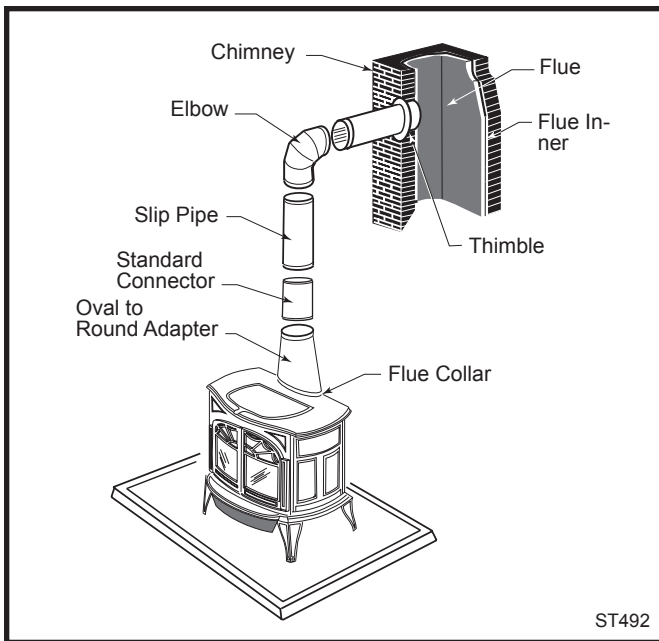

Fig. 6 An exploded view of the chimney connection in a freestanding masonry installation.

A special piece called the “thimble sleeve,” slightly smaller in diameter than standard connectors and most thimbles, will facilitate the removal of the chimney connector system for inspection and cleaning. (fig. 7) Thimble sleeves should be available from your local dealer.

To install a thimble sleeve, slide it into the breech until it is flush with the inner flue wall. Do not extend it into the actual flue passage, as this could interfere with the draft.

The thimble sleeve should protrude 1-2” (25-50 mm) into the room. Use furnace cement and thin gasketing to seal the sleeve in place in the thimble. Secure the chimney connector to the outer end of the sleeve with sheet metal screws.

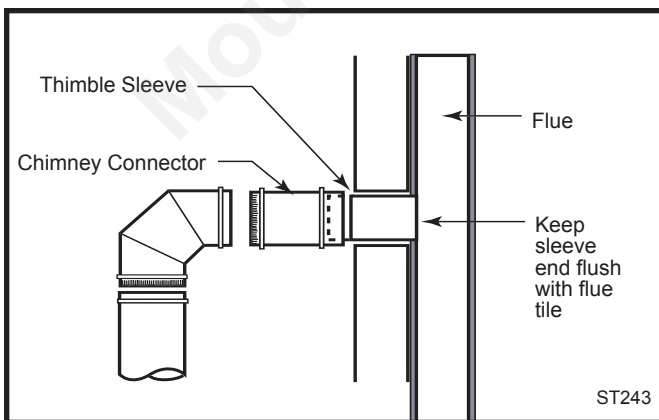

Fig. 7 The thimble, made of either ceramic or metal, must be cemented securely in place.

Without a thimble, a suitable length of chimney connector can be extended through the breech to the inner face of the flue liner, and cemented securely in place. Additional pieces of connector are then attached with sheet metal screws.

Fireplace Installations

The chimney connector may be connected to the chimney above the fireplace opening or through the fireplace.

Above the Fireplace

The Defiant may be connected to a chimney above a fireplace opening. (Fig. 8) In such installations, the stove is positioned on the hearth in front of the fireplace and the chimney connector rises from the stove top and then angles ninety degrees back into the chimney. The chimney liner should extend to the point at which the chimney connector enters the chimney.

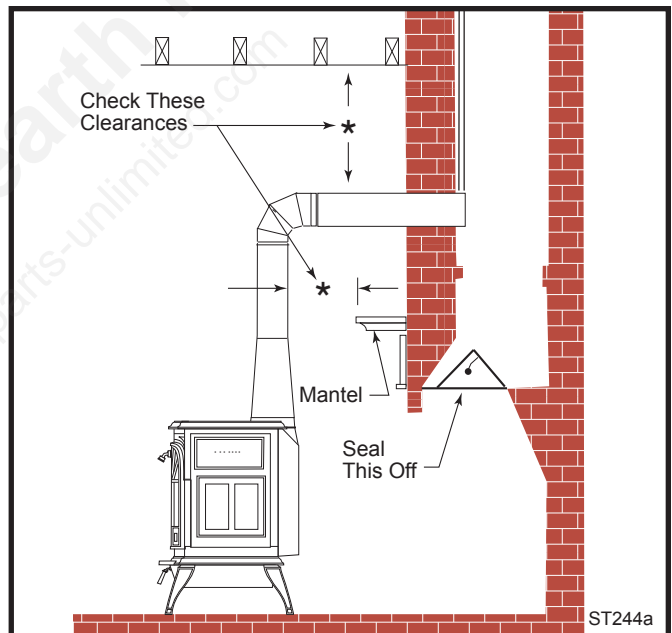

Fig. 8 In this installation, the chimney connector attaches to the chimney above the fireplace opening.

If the chimney connector in your installation enters the chimney above a fireplace, follow all the guidelines mentioned above for freestanding installations. In addition, give special consideration to the following points:

- Check the clearance between the stove and the chimney connector, and any combustible trim or the mantel.
- Check the clearance between the chimney connector and the ceiling. The clearance should be at least 24” (610 mm).
- The fireplace damper must be sealed to prevent room air from escaping up the flue. However, it must be possible to re-open the damper to inspect or clean the chimney.

Through the Fireplace

If your fireplace opening height is at least 29" (737 mm), you may install a Defiant through the opening using a "positive connection" kit, available from your local dealer. Positive connection kits ensure a tight fit between the stove flue collar and the chimney flue. (Fig. 9)

Fireplace installations, whether connected to the flue above or through the fireplace opening, have special clearance requirements to adjacent trim and the mantel. You'll find the required safe clearances for Defiant fireplace installations on Page 12.

Floor protection requirements also apply to fireplace installations. This information is on Page 10.

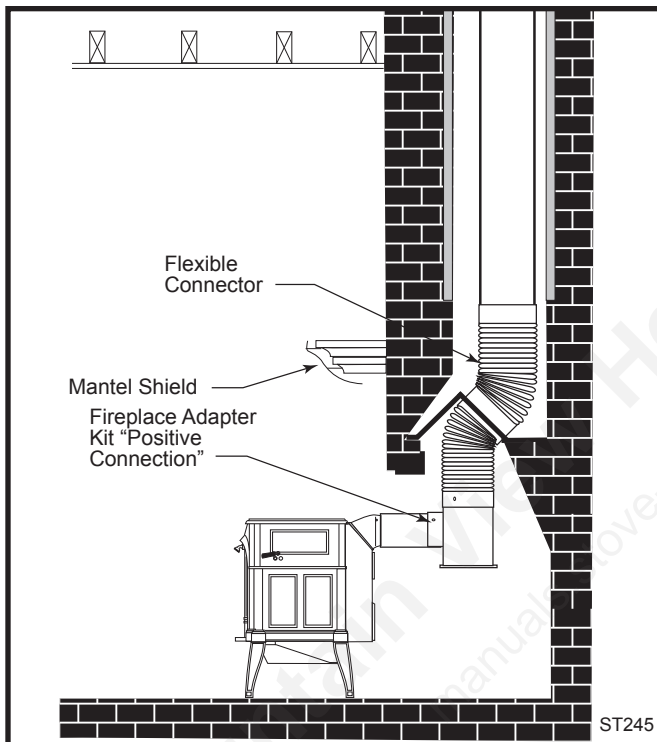

Fig. 9 Through the fireplace installation.

Wall Pass-Throughs

Whenever possible, design your installation so the connector does not pass through a combustible wall. If you are considering a wall pass-through in your installation, check with your building inspector before you begin. Also, check with the chimney connector manufacturer for any specific requirements.

Accessories are available for use as wall pass-throughs. If using one of these, make sure it has been tested and listed for use as a wall pass-through.

In the United States, the National Fire Protection Association (NFPA) has established guidelines for passing chimney connectors through combustible walls. Many building code inspectors follow these guidelines when approving installations.

Figure 10 shows one NFPA-recommended method. All combustible material in the wall is cut away from the single-wall connector to provide the required 12" (305 mm) clearance. Any material used to close up the opening must be noncombustible.

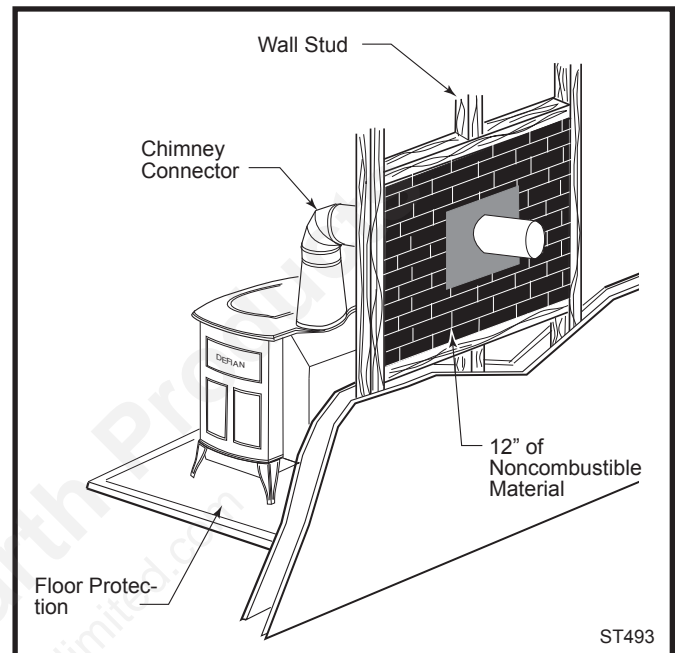

Fig. 10 An approved wall pass-through for the United States.

Three other methods are also approved by the NFPA:

- Placing a section of chimney connector inside a ventilated thimble, which in turn is separated from combustibles by 6" (152mm) of fiberglass insulating material.
- Placing a section of chimney connector inside a section of 9" (230mm) diameter, solid-insulated, factory-built chimney, with 2" (50mm) of air space between the chimney section and combustibles.
- Using a section of solid-insulated double-wall high temperature chimney, with an inside diameter the same as the chimney connector, at least one inch of solid insulation, and a minimum of 9" (229 mm) air space between the outer wall of the chimney section and combustibles.

In Canada, The Canadian Standards Association has established different guidelines for wall pass-throughs. Figure 11 shows one method, in which all combustible material in the wall is cut away to provide the required 18" (457mm) clearance for the connector. The resulting space must remain empty. A flush-mounted sheet metal cover may be used on one side only. If covers must be used on both sides, each cover must be mounted on noncombustible spacers at least 1" (25mm) clear of the wall.

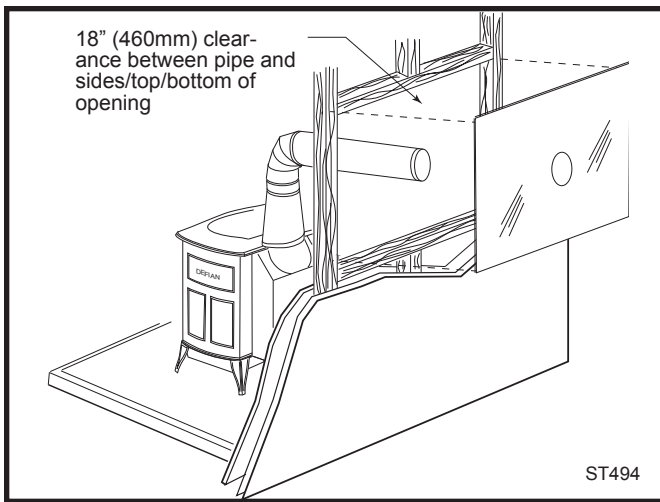

Fig. 11 An approved wall pass-through for Canada.

Your local dealer or your local building inspector can provide details for other approved methods of passing a chimney connector through a combustible wall in your area. In Canada, this type of installation must conform to CAN/CSA-B365, Installation Code for Solid Fuel Burning Appliances and Equipment.

NOTE: Do not vent your Defiant into a factory-built (zero-clearance) fireplace. These appliances and their chimneys are specifically designed as a unit for use as fireplaces. It may void the listing or be hazardous to adapt them for any other use.

DO NOT CONNECT THE DEFIANT TO ANY AIR DISTRIBUTION DUCT OR SYSTEM.

Floor Protection

A tremendous amount of heat radiates from the bottom plate of your stove. The floor area directly under and around the stove will require protection from radiant heat as well as from stray sparks or embers that may escape the firebox.

Heat protection is provided through the use of a Vermont Castings Bottom Heat Shield #1905. Spark and ember protection must be provided by a floor protector constructed with noncombustible material as specified.

Most installations will require the bottom heat shield be attached. Only when the stove is placed on a completely noncombustible surface such as unpainted concrete over earth may it be used without the heat shield.

Even when the bottom heat shield is installed, you must provide special protection to the floor beneath. For installations with the heat shield attached, use a noncombustible floor protector such as 1/4" nonasbestos mineral board or equivalent, or 24 gauge sheet metal. The floor protector may be covered with a noncombustible decorative material if desired. Do not obstruct the space under the heater.

Protection requirements vary somewhat between the United States and Canada as follows:

In U. S. installations the floor protector is required under the stove and must extend at least 16" (not including the ash lip) from the front of the stove ("F", Fig. 12), and at least 6" from the sides and rear. ("D" and "E", Fig. 12)

It must also extend under the chimney connector and 2" to either side. ("C", Fig. 12) For the 8" (203 mm) connector, the protector must be a minimum of 12" (305 mm) wide. For the 6" (152 mm) connector, the protector must be 10" (254 mm) wide. The protector must be centered under the connector.

To meet these requirements, a floor protector must be at least 42" wide and 43" deep.

In Canada: A noncombustible floor protector is required under the stove as well. The floor protector must extend 18" (457 mm) to the front ("F", Fig. 12), and 8" (203 mm) from the sides and rear. ("D" and "E", Fig. 12)

To meet these requirements, a floor protector must be at least 46" (1168 mm) wide and 47" (1194 mm) deep.

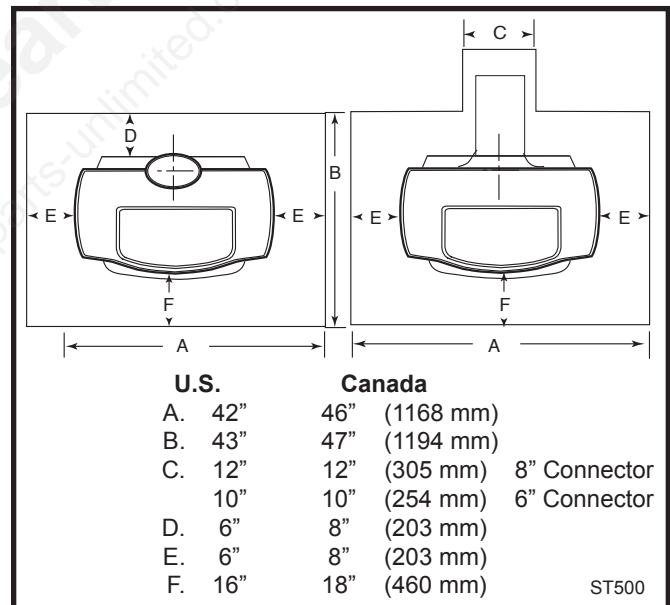

Fig. 12 Required floor protection dimensions.

Floor Protection for Fireplace Installation

Do not assume that your fireplace hearth is completely noncombustible. Many fireplace hearths do not satisfy the "completely noncombustible" requirement because the brick or concrete in front of the fireplace opening is supported by heavy wood framing. Because heat passes readily through brick or concrete, it can easily pass through to the wood. As a result, such fireplace hearths can be a fire hazard and are considered a combustible floor.

For all fireplace installations, follow the floor protection guidelines described above. Keep in mind that many raised hearths will extend less than the required clearance from the front of the heater. In such cases, sufficient floor protection as described above must be added in front of the hearth to satisfy the minimum floor protector requirement from the front of the stove: 16" (410 mm) in the United States and 18" (460 mm) in Canada. Hearth rugs do not satisfy the requirement for floor protection as they are not fire proof.

Fireplace installations also have special clearance requirements to the side walls, side decorative trim and fireplace mantel. Refer to the information on fireplace and mantel trim shields in this section.

Keep the Stove a Safe Distance from Surrounding Materials

Both a stove and its chimney connector radiate heat in all directions when operating, and nearby combustible materials can overheat dangerously if they are too close to the heat source. A safe installation requires that adequate clearance be maintained between the hot stove and its connector and nearby combustibles.

Clearance is the distance between either your stove or chimney connector, and nearby walls, floors, the ceiling, and any other fixed combustible surface. The Defiant has specific clearance requirements that have been established after careful research and testing. These clearance requirements must be strictly observed.

In addition, keep furnishings and other combustible materials away from the stove. In general, a distance of 48" (1220 mm) must be maintained between the stove and moveable combustible items such as drying clothes, furniture, newspapers, firewood, etc. Keeping those clearance areas empty assures that nearby surfaces and objects will not overheat.

Safe Ways to Reduce Clearances

Clearance requirements are established to meet every installation possibility, and they involve the combination of these variables:

- When the stove has no listed heat shield mounted on it.
- When the wall has no heat shield mounted on it.
- When the wall has a heat shield mounted on it.
- When the wall and stove have heat shields.

In general, the greatest clearance is required when you place a stove and its connector near a wall with no heat shield.

For example, when the Defiant is installed parallel to the rear wall and no shield is used, it must be at least 33" (815 mm) from the wall behind it and at least 24" (610 mm) from walls on either side.

If the Defiant is installed in a corner and no shield is used, the corners of the stove must be at least 23" (585 mm) from nearby walls.

Clearances may be reduced only by means approved by the regulatory authority, and in accordance with the clearances listed in this manual. Refer to Pages 10 - 13 for approved clearance reduction specifications.

Use only Vermont Castings Defiant Rear Heat Shield #000-1901.

NOTE: Alcove installation of the Defiant is not permitted.

Wall Shields

One way to reduce clearances is with a wall shield constructed of 24 gauge or heavier sheet metal, or of another noncombustible material such as 1/2" (13 mm) insulation board such as Durock® or Wonderboard®, or common brick "laid on flat," with the 3½" (90 mm) side down.

Shields must be spaced out from the combustible surface 1" (25 mm) on noncombustible spacers, as in Figure 13. The spacers should not be directly behind the stove or chimney connector.

Air must be able to flow between the wall and the shield. At least 50% of the bottom 1" (25 mm) of the shield must be open, and the shield must be open at the top. Metal screening across the top will keep small stray objects from being trapped behind the shield. (Fig. 13)

The shield must be a minimum of 48" (1220 mm) tall, and must extend at least 20½" (520 mm) higher than the top of the stove, whichever is higher. The shield behind the chimney connector must be 30" (760 mm) wide, centered behind the pipe; for installations that use an approved prefabricated chimney to pass through the ceiling, the shield behind the chimney connector must stop 1" (25 mm) below the ceiling.

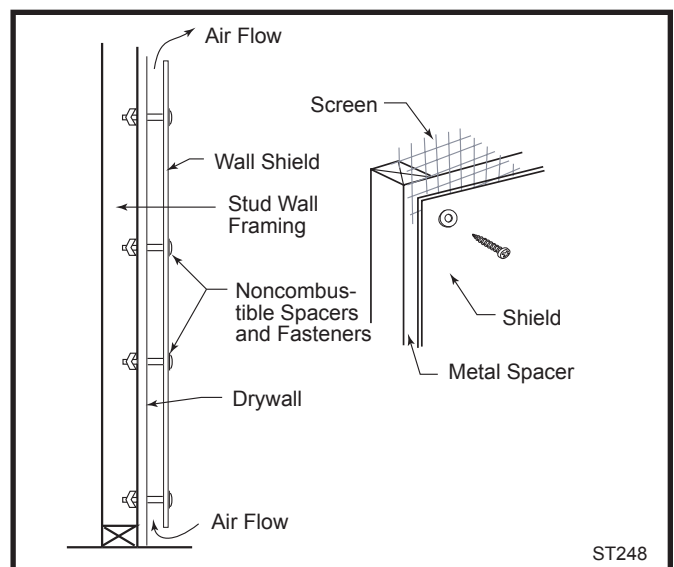

Fig. 13 Approved wall shield construction.

Fireplace and Mantel Trim Shields

A fireplace installation requires special clearance between the side of the stove and the right and left walls, between the side of the stove and the decorative side trim on the fireplace face, and between the top of the stove and the mantel.

Noncombustible shields installed 1" (25 mm) away from the combustible surface on noncombustible spacers, called ventilated shields, may be used to reduce clearances.

To protect a mantel from the heat of a stove in a fireplace installation, use a custom-made ventilated mantel shield that is at least 48" (1220 mm) long, centered over the stove. (Fig. 14) Ventilated shields for side trim must extend the full length of the trim.

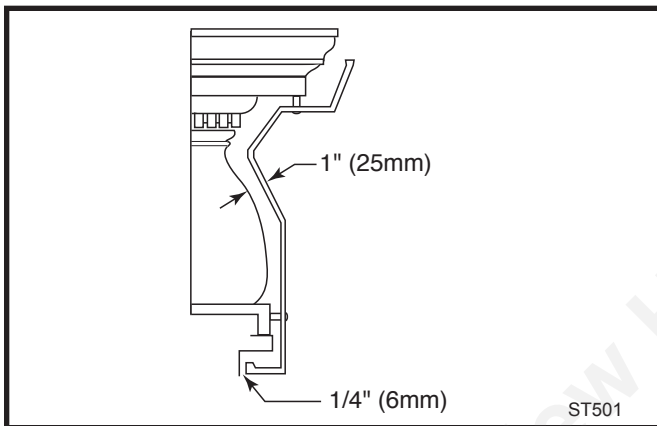

Fig. 14 A custom-formed mantel shield.

An unprotected mantel ("A", Fig. 15) cannot be more than 9" (230 mm) deep and must have a minimum clearance of 39" (991 mm), measured from the stove's top plate. With a ventilated shield, this clearance may be reduced safely to 23" (584 mm).

Unprotected top trim (B) protruding 9" (230 mm) or less from the face of the fireplace must be a minimum of 39" (991 mm) from the stove's top surface. With a ventilated trim shield, this clearance may be reduced safely to 23" (584 mm).

Unprotected side trim (C) that protrudes 2" (51 mm) or less from the face of a fireplace must have a minimum clearance of 14" (356 mm), measured from the stove's top side edge. With a ventilated trim shield, the clearance may be reduced safely to 6" (152 mm). If the trim extends more than 2" (51 mm), it is subject to the requirements for wall clearance.

The charts and sample installations that follow list all the clearances required for the various installation configurations of the Defiant.

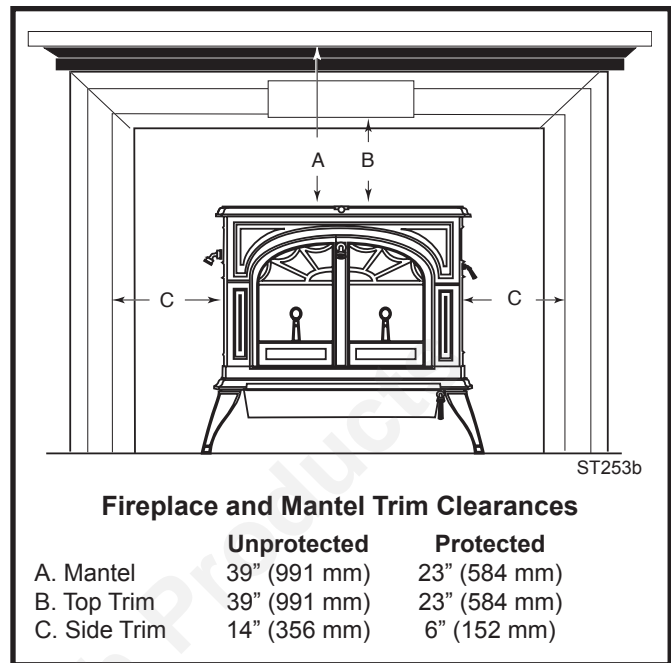

Fig. 15 Maintain clearances to combustible components of the mantelpiece.

Defiant Clearance Chart

for use with either a 6" or 8" chimney connection

	Stove Clearance					
	Unprotected Surfaces			Protected Surfaces		
	Stove Installed Parallel to Wall		Stove in Corner	Stove Installed Parallel to Wall		Stove in Corner
	Side	Rear	Corners	Side	Rear	Corners
No stove heat shields	(A) 24" (610 mm)	(B) 33" (840 mm)	(C) 23" (585 mm)	(D) 14" (355 mm)	(E) 28" (710 mm)	(F) 18" (460 mm)
Stove, top exit with rear heat shield, no connector heat shields	(G) 24" (610 mm)	(H) 21" (533 mm)	(I) 17" (430 mm)	(J) 14" (355 mm)	(K) 17" (430 mm)	(L) 12" (305 mm)
Stove, top exit with rear heat shield, and heat shields on connector	(M) 24" (610 mm)	(N) 17" (430 mm)	(O) 17" (430 mm)	(P) 14" (355 mm)	(Q) 17" (430 mm)	(R) 12" (305 mm)
Stove, top exit with rear heat shield, and double-wall chimney connector*	(S) 24" (610 mm)	(T) 17" (430 mm)	(U) 17" (430 mm)	(V) 14" (355 mm)	(W) 15" (380 mm)	(X) 12" (305 mm)
Stove, rear exit with rear heat shield only	(Y) 27" (686 mm)	(Z) 24" (610 mm)	N/A	(AA) 17" (430 mm)	(BB) 20" (508 mm)	N/A
	Chimney Connector Clearance					
	Unprotected Vertical Surfaces			Protected Vertical Surfaces		
Single-wall connector	30" (760 mm)			25" (635 mm)		
Single-wall connector; rear heat shield on stove only	18" (460 mm)			14" (355 mm)		
Single-wall connector with shields, and rear heat shield on stove	14" (355 mm)			14" (355 mm)		
Double-wall chimney connector	14" (355 mm)			12" (305 mm)		
Single-wall connector	Unprotected or Protected Ceiling Surfaces					
	24" (610 mm)					
	Clearance to Combustibles in Front of Stove					
	All Installations 48" (1220 mm)					

* Using a listed double wall oval to round connector.

Defiant Clearance Diagrams

for use with either a 6" or 8" chimney connection

Unprotected Surfaces		Protected Surfaces	
Stove Installed Parallel to Wall	Stove in Corner	Stove Installed Parallel to Wall	Stove in Corner
Top Exit Installations, no heat shields			
Top Exit Installations, heat shield on stove, no shields on single-wall connector			
Top Exit Installations, heat shield on stove, heat shields on single-wall connector			
Top Exit Installations, heat shield on stove, double-wall chimney connector			
Rear Exit Installations, rear heat shields			
	N/A		N/A

ST486a

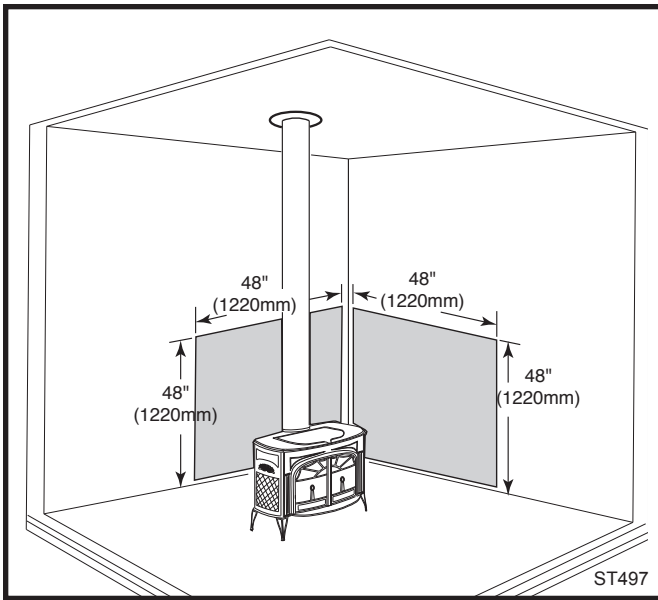

Fig. 16 Parallel installation, vertical chimney connector, two wall shields. Reduced clearances for both rear and side walls. Wall shields may meet at corner if desired. Shielding for connector is centered behind connector.

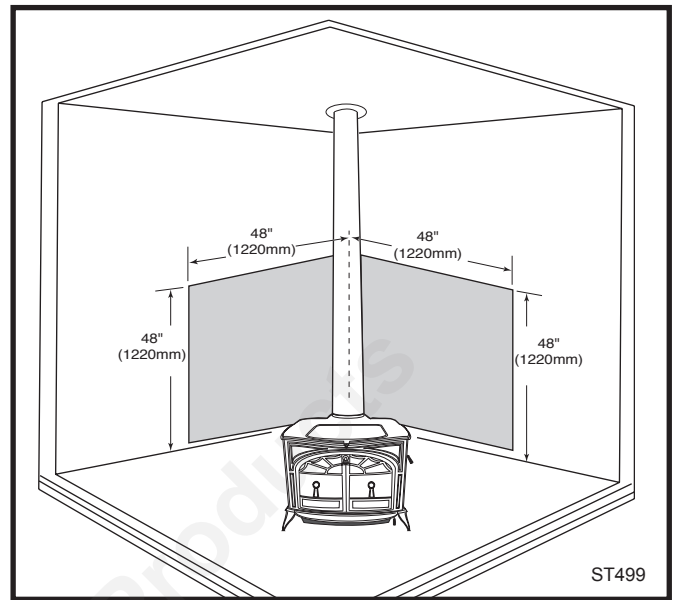

Fig. 18 Corner installation, vertical chimney connector, two wall shields. Reduced side clearances. Wall shield **MUST** meet at corner.

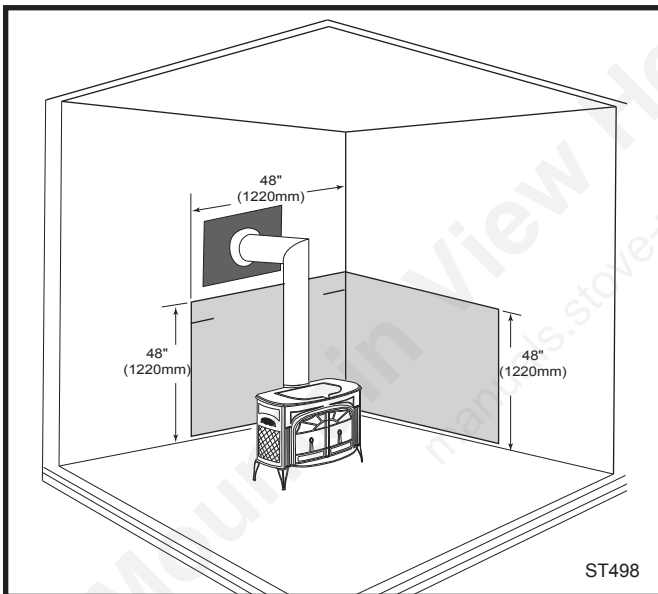

Fig. 17 Parallel installation with rear wall pass-through, two wall shields. Reduced clearances to both rear and side walls. Wall shields may meet at corner if desired. Wall pass-through must comply with codes. Refer to "Special Installations."

Stove Heat Shields

The Vermont Castings Defiant Rear Heat Shield, shown below, is one way to reduce the clearance to the rear wall. The rear heat shield can be installed in any setting. However, since the chimney connector also radiates heat toward the wall, you must use a chimney connector shield whenever you use the rear heat shield.

Clearance reductions with the rear heat shield apply only to the wall to the rear in parallel installations. Neither the side clearance requirement nor the clearance requirement in corner installations may be reduced.

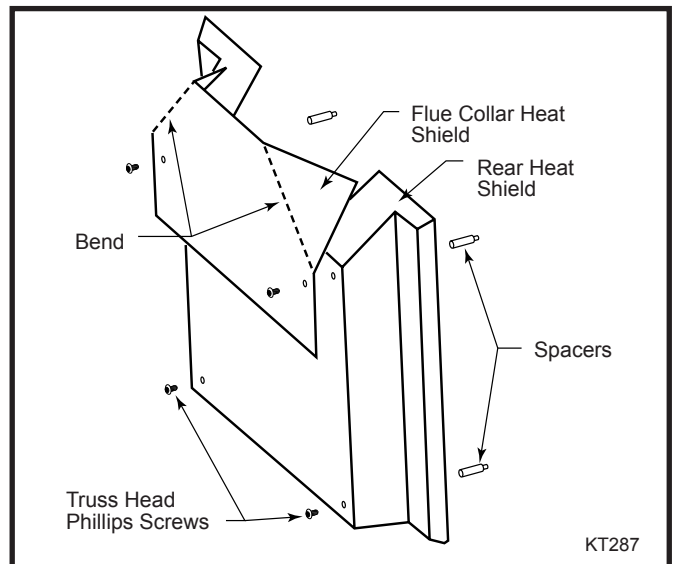

Fig. 19 Defiant rear heat shield with flue collar heat shield for top exit configuration.

Distance from the Center of the Flue Collar to the Wall

The information on this page is helpful in planning stove placement, particularly in those installations with chimneys that pass through the ceiling. However, this is not a clearance chart. Final stove clearances must adhere to the guidelines in the clearance chart on Page 12.

Note that rear dimensions differ for installations with 6" or 8" chimney connectors.

Defiant with No Stove or Connector Heat Shields

Unprotected Surfaces			Protected Surfaces		
Parallel Installations		Corner Installations	Parallel Installations		Corner Installations
Side (A)	Rear (B)	Corner (C)	Side (D)	Rear (E)	Corner (F)
39½" (1003 mm)	6" chimney: 33" (838 mm) 8" chimney: 34" (864 mm)	34" (864 mm)	29½" (749 mm)	6" chimney: 28" (711 mm) 8" chimney: 29" (737 mm)	29" (737 mm)

Defiant with Rear Heat Shield Only

Unprotected Surfaces			Protected Surfaces		
Parallel Installations		Corner Installations	Parallel Installations		Corner Installations
Side (A)	Rear (B)	Corner (C)	Side (D)	Rear (E)	Corner (F)
39½" (1003 mm)	6" chimney: 21" (533 mm) 8" chimney: 22" (559 mm)	28" (710 mm)	29½" (749 mm)	6" chimney: 17" (432 mm) 8" chimney: 18" (457 mm)	23" (584 mm)

Defiant With Rear Heat Shield and Shielded Connector:

Side (A)	Rear (B)	Corner (C)	Side (D)	Rear (E)	Corner (F)
39½" (1003mm)	6" chimney: 17" (432 mm) 8" chimney: 18" (457 mm)	28" (710 mm)	29½" (749 mm)	6" chimney: 17" (432 mm) 8" chimney: 18" (457 mm)	23" (584 mm)

Defiant With Rear Heat Shield and Double-wall Connector:

Side (A)	Rear (B)	Corner (C)	Side (D)	Rear (E)	Corner (F)
39½" (1003mm)	6" chimney: 17" (432 mm) 8" chimney: 18" (457 mm)	28" (710 mm)	29½" (749 mm)	6" chimney: 15" (381 mm) 8" chimney: 16" (406 mm)	23" (584 mm)

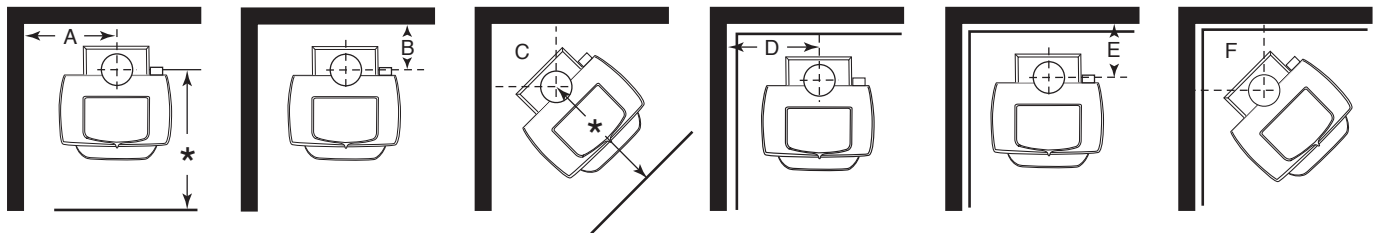

* This distance, from the center of the flue collar to the front edge of the hearth, is the same for all installations on this page: 34" (865 mm) in the United States and 36" (914 mm) in Canada.

Assembly

Set Up Your Stove

Cast iron stoves are heavy, and it will take two to four people to move your Defiant into position.

Wipe the protective coating of oil from the griddle with a clean dry rag or a paper towel.

Install the handle on the griddle. Slip the bolt through a washer, a nylon bushing, then through the handle and the other bushing, then through the steel spacer and into the griddle tab. (Fig. 20) Tighten securely.

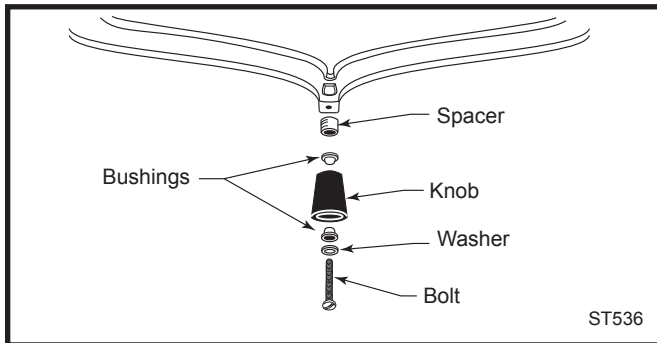

Fig. 20 Attach the griddle handle.

Install Stove Legs

The stove is shipped with the legs attached. In some instances, the legs may have been removed. Follow these instructions to reattach the legs. Install the stove legs (Fig. 21) using the hex head bolts from the parts bag. Use 3/8" washers with all four legs; the door handle holder installs on the right front leg. Position the holder so the hole to accept the handle hub faces out from the right side of the stove. Tighten the bolts firmly.

CAUTION: Overtightening can strip tapped threads.

NOTE: When moving the stove, lift the stove to take weight off the legs whenever possible. Dragging or sliding the stove, especially across rough surfaces can cause the legs to loosen or even break.

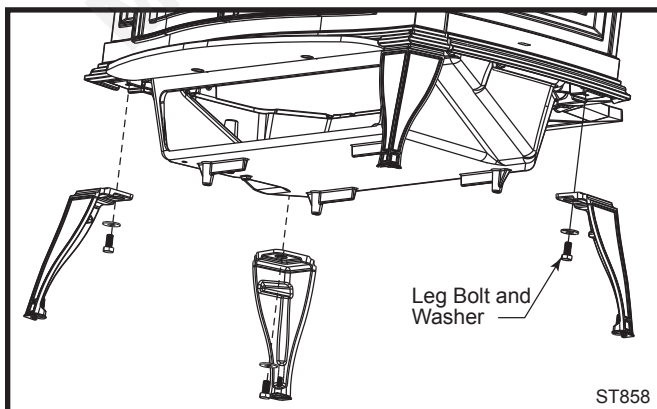

Fig. 21 Attach the stove legs.

Storing the Handle

Use the removable handle to open or close the doors. After using it, remove the handle so it will not get hot. Store the handle in the handle holder installed behind the right front leg. (Fig. 22)

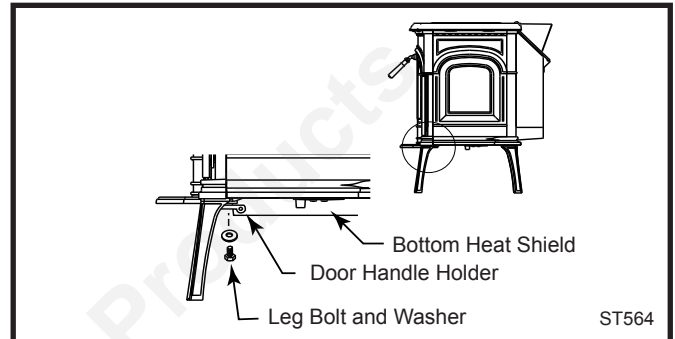

Fig. 22 Handle holder and heat shield positions.

Install the Optional Bottom Heat Shield

NOTE: The Bottom Heat Shield is required in most installations. Refer to Floor Protection, Page 10, for further details.

1. Remove the four 10-24 x 1/2" hex head bolts from the corners of the ash drop on the stove bottom.
2. Screw the four 1 1/4" spacers into the holes from which you removed the bolts, finger-tight.
3. Align the bottom heat shield against the spacers with the stepped side toward the rear of the stove.
4. Secure the shield with the four hex head bolts removed from the stove bottom previously. Tighten securely. (Fig. 23)

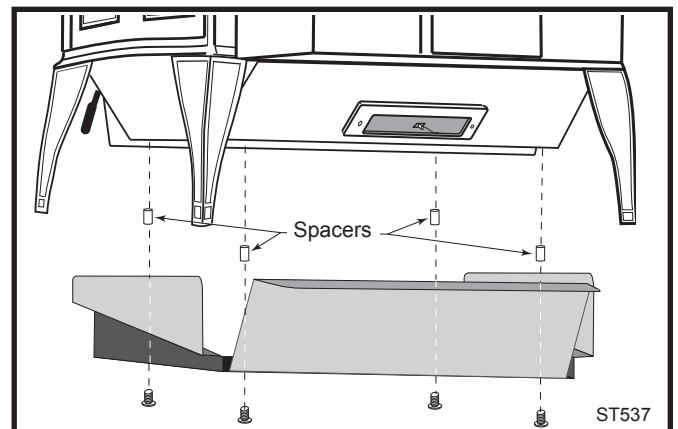

Fig. 23 Attach the optional bottom heat shield.

Install the Optional Ash Door Heat Shield

1. Remove the two Phillips pan head screws from the ash door.
2. Insert the screws through the ash door heat shield (from the painted side), place the 5/16" spacers over the screws, and carefully thread them back into the original holes. (Fig. 24) The curved lip should be upward, under the ashlip of the stove.
3. Tighten securely.

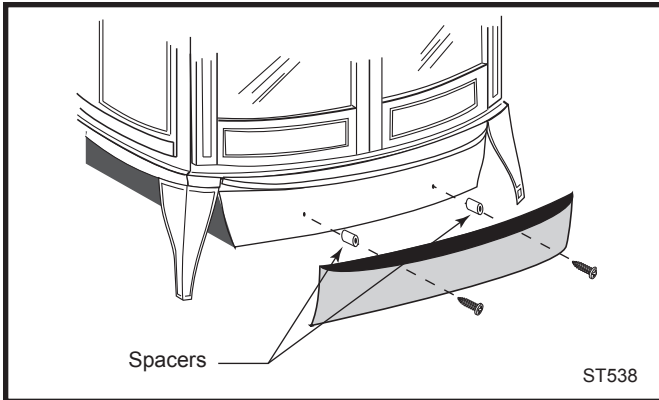

Fig. 24 Install the ashdoor heat shield.

Adjust the Leg Levellers

Lift the stove slightly so there is no weight on the leg while making the adjustment.

Reverse the Flue Collar (If Necessary)

Reverse the flue collar by removing the two screws that attach it to the back of the stove. Be sure the gasket around the flue collar opening is in position when you screw the collar back onto the stove.

Attach the Damper Handle

Use the 1/4" -20 x 3" screw to attach the damper handle to the damper stub on the left side.

Attach the Primary Air Thermostat Handle

The primary air thermostat handle is the smaller of the two black handles. Secure the handle to the stub on the right side of the stove with an 8-32 x 2" slot head machine screw. (Fig. 25)

Assemble the Removable Insert Handle

The ceramic removable insert handle opens and closes the front doors. Remove after each use, and store it in the handle holder behind the right front leg. Assemble the handle by passing the 3 3/8" screw through the ceramic shaft and into the bright metal nub. (Fig. 26) Tighten carefully until snug.

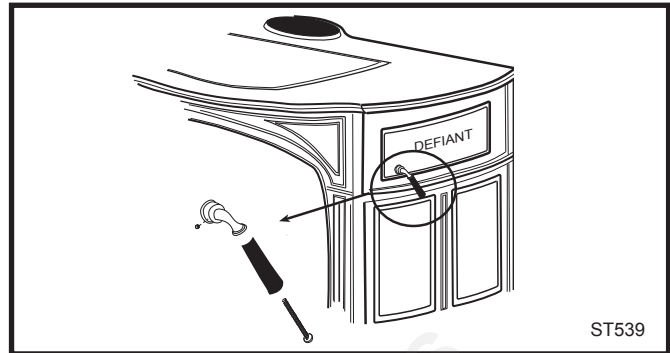

Fig. 25 Attach the thermostat handle.

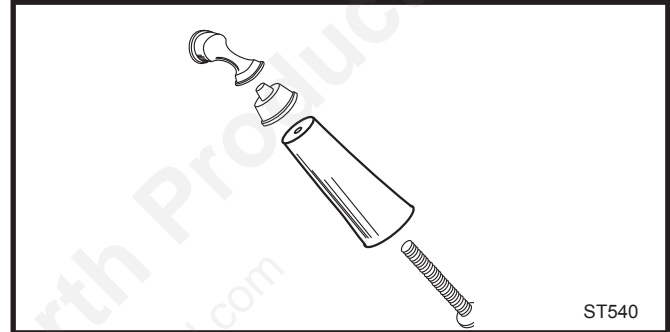

Fig. 26 Assemble the front door handle.

Operation

The Defiant Controls

Two controls regulate the performance of the Defiant: a **primary air control** supplies oxygen for the fire, and a **damper** directs air flow within the stove to activate and deactivate the catalytic combustor. (Fig. 27)

Symbols cast into the stove are reminders of the correct directions for using the controls. 'Left' and 'right' in these directions mean *as you face the stove*.

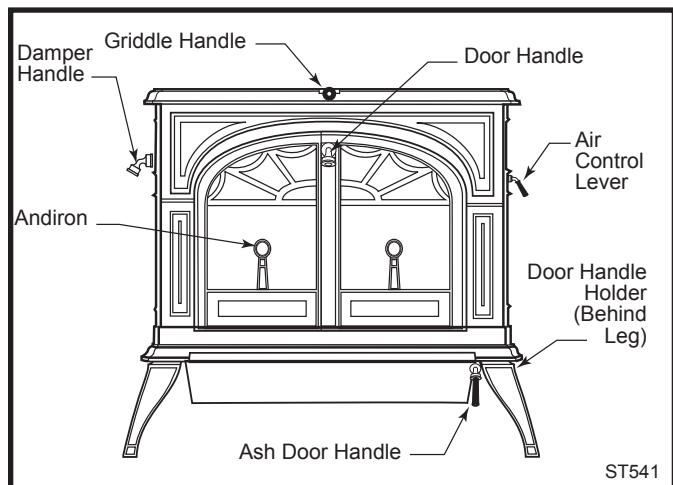

Fig. 27 The Defiant's controls are conveniently located and easy to operate.

A Single Air Control Regulates Heat Output and Burn Time

The **primary air control lever**, on the right side of the stove, controls the amount of incoming air for starting, maintaining, and reviving a fire.

More air entering the stove makes the fire burn hotter and faster, while less air prolongs the burn at a lower heat output level. (Fig. 28)

For the greatest air supply and maximum heat output (but the shortest burn time), move the lever toward the front of the stove. For a fire that will last longer with less heat, move the lever toward the rear of the stove.

The Defiant's air control system includes an automatic thermostat to ensure an even heat output at whatever manual setting you select. The thermostat senses the heating and cooling of the stove surface and adjusts the air valve accordingly.

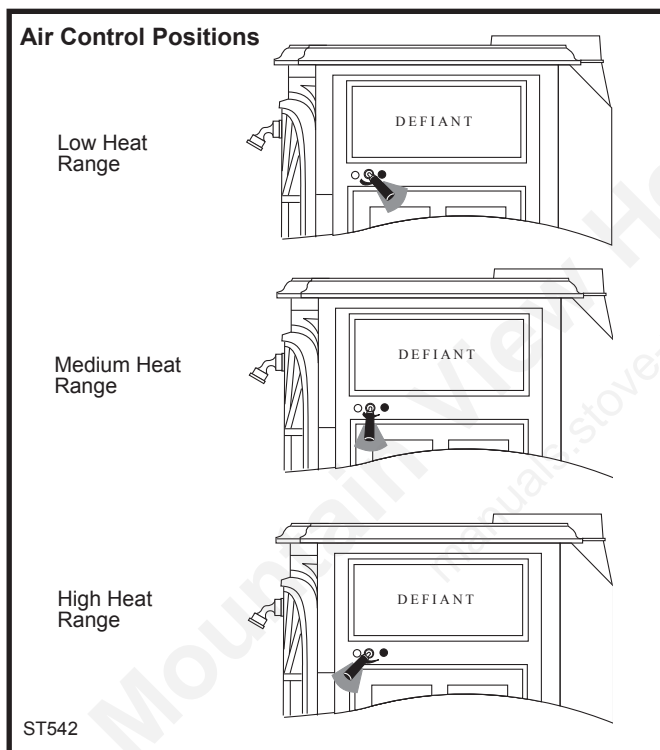

Fig. 28 The handle also may be positioned anywhere between the two extremes for different heat levels.

A Damper Directs Air Flow Within the Stove

The **damper handle** on the left side of the stove operates the damper to direct air flow within the stove.

The damper is **open** when the handle points to the **rear**, enabling smoke to pass directly into the chimney. The damper must be open when starting or reviving a fire, and whenever the griddle or doors are opened.

The damper is **closed** when the handle points **forward**. Smoke travels through the catalytic combustion system where it can be further burned, before passing up the chimney. (Fig. 29)

The damper is either fully open or fully closed. There are no intermediate positions. When closing the damper, be sure to pull firmly enough to snap the handle into the locked position.

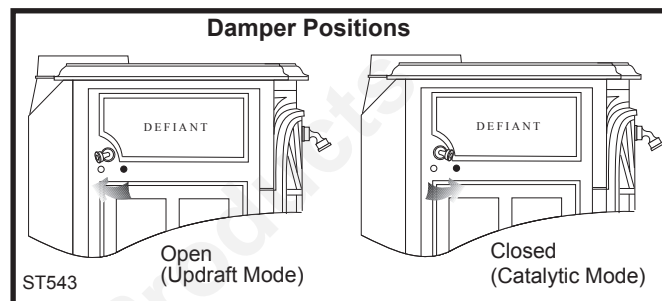

Fig. 29 The Defiant's damper operating positions.

Two Ways to Add Fuel

The Defiant's griddle lifts for convenient top-loading of logs, and is the easiest way to add fuel. (Fig. 30)

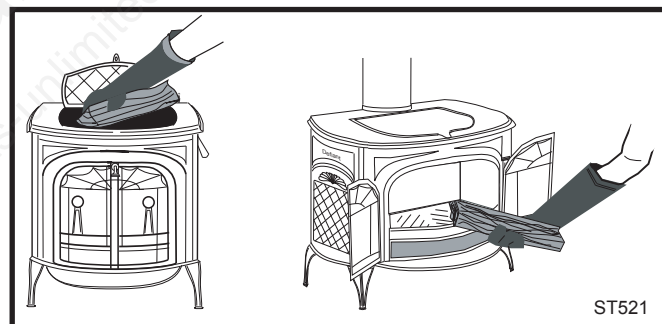

Fig. 30 Top loading is the best way to add fuel during regular use. Front loading is useful for kindling a fire.

However, the front doors open as well for adding an occasional log to a fire. If the stove is equipped with 8" (203 mm) stove pipe, the front doors may be opened (or even removed) and the optional Defiant spark screen placed in the opening for open-fire viewing. **The Defiant is not approved for operation with the front doors open if equipped with a 6" (152 mm) chimney connector.**

To open the front doors, insert the handle into the door latch stub and turn it to the left and up. (Fig. 31)

To close them, always close the left door first. Turn the handle in the right door to the left and up (to the open position) and close it. Finally, push on the door as you turn the handle to the right and down. The doors will draw in slightly, and the handle should offer some resistance as you turn it to the closed position.

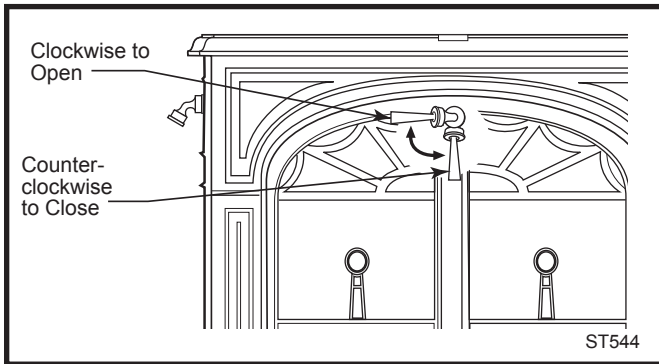

Fig. 31 To open the front doors, turn the handle clockwise.

To reduce the risk of breaking the glass, avoid striking the glass or slamming the doors.

When you're not using the door handle, store it in the holder behind the left front leg of the stove. Be careful to not drop the handle, since it is breakable.

WARNING: Fireplace stoves equipped with doors should be operated only with doors fully open or doors fully closed. If doors are left partly open, gas and flame may be drawn out of the fireplace stove opening, creating risks from both fire and smoke.

The Defiant may be used as a fireplace with the front doors open or removed, **BUT only when it is equipped with 8" (203mm) stove pipe and only when the optional spark screen is placed correctly in the opening to protect against the possibility of sparks and embers leaving the stove.**

Use only the Defiant spark screen, Item #1907, with your Defiant.

Defiant spark screens are available from your Vermont Castings Dealer.

Infra-Red Reflective Glass Panels for Clear Fire Viewing

The outer surfaces of the ceramic glass panels have an infrared-reflective coating which keeps the inner surfaces warm. This design, along with a pre-heated 'airwash,' makes clear fire viewing possible at most firing levels.

Andirons Help Protect the Glass

Your stove has andirons to keep logs away from the glass panels. The andirons are essential to maintain clear fireviewing, and should be left permanently in place. Since the andirons may slightly hinder refueling through the front doors, most stove owners will prefer the convenience of top loading through the griddle. Do not place fuel between the andirons and the doors.

Burn Only High-Quality Wood

The Defiant is designed to burn natural wood only; do not burn fuels other than that for which it was designed.

You'll enjoy the best results when burning wood that has been adequately air-dried. The wood should be 22-24" (559-610 mm) in length. Avoid burning "green" wood that has not been properly seasoned. **Do not burn construction materials;** they often contain chemicals and metals that can damage the catalytic combustor or pollute the air. Do not burn ocean drift-wood; when it burns, the salt it absorbs will attack the cast iron.

The best hardwood fuels include oak, maple, beech, ash, and hickory that has been split, stacked, and air-dried outside under cover for at least one year.

If hardwood is not available, you can burn softwoods that include tamarack, yellow pine, white pine, Eastern red cedar, fir, and redwood. These should also be properly dried.

Store wood under cover to keep it dry. The longer it is stored, the better heating and fire-viewing performance you will enjoy. Even for short-term storage, however, keep wood a safe distance from the heater and keep it out of the areas around the heater used for refueling and ash removal.

A Surface Thermometer is a Valuable Guide to Operation

An optional surface thermometer tells you when to adjust the air control, and when to refuel. (Fig. 32)

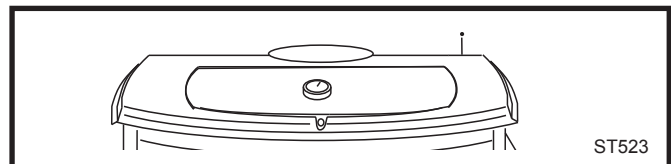

Fig. 32 Take temperature readings with a thermometer located in the middle of the griddle.

For example, when the thermometer registers at least 450°F. (230°C) after start-up you know that the stove is hot enough to begin catalytic combustion and that it may be time to close the damper. Note that the stove will warm up much sooner than the chimney, though; a warm chimney is the key to easy, effective stove operation. Please review the draft management information on Page 26 to see how the size, type, and location of your chimney will affect your stove operation. When thermometer readings drop below 350°F. (175°C) it's time to adjust the air control for a higher burn rate or to reload the stove. A temperature reading over 750°F. (385°C) is a sign to cut back on the air supply to slow the burn rate.

Use the following temperature ranges as a guide:

- Readings in the 350°-500°F. (175°-260°C) range indicate low to medium heat output.
- 500°-600°F. (260°-315°C) readings indicate medium heat output.
- Readings of 600°-750°F. (315-385°C) indicate high heat output. Operating your Defiant continuously at griddle temperatures of 750° F. (385°C) or higher may damage the cast iron or enamel finish.

Use the Air Control Settings that Work Best for You

No single air control setting will fit every situation. Each installation will differ depending on the quality of the fuel, the amount of heat desired, and how long you wish the fire to burn; outdoor air temperature and pressure also affect draft.

The control setting also depends on your particular installation's "draft," or the force that moves air from the stove up through the chimney. Draft is affected by such things as the length, type, and location of the chimney, local geography, nearby obstructions, and other factors. See Page 26 for details on how the installation affects performance.

Too much draft may cause excessive temperatures in the Defiant, and could even damage the combustor. On the other hand, too little draft can cause backpuffing into the room and/or the "plugging" of the chimney or combustor.

How do you know if your draft is excessively high or low? Symptoms of too much draft include an uncontrollable burn or a glowing-red stove part. Signs of weak draft are smoke leaking into the room through the stove or chimney connector joints, low heat, and dirty glass.

In some newer homes that are well-insulated and weather-tight, poor draft may result from insufficient air in the house. In such instances, an open window near the stove on the windward side of the house will provide the fresh air needed.

Another option for getting more combustion air to the stove is to duct air directly from the outside to the stove. In some areas provisions for outside combustion air are required in all new construction.

With an optional outside air adapter, No. 1904, your Defiant will accept a duct to deliver outside air for combustion.

When first using the stove, keep track of the air control settings. You will quickly find that a specific setting will give you a fixed amount of heat. It may take a week or two to determine the amount of heat and the length of burn you should expect from various settings.

Most installations do not require a large amount of combustion air, especially if adequate draft is available. **Do not for any reason attempt to increase the firing of your heater by altering the air control adjustment range outlined in these directions.**

Use the following air control settings as a starting point to help determine the best settings for your installation. Each is described as a fraction of the total distance the lever may be moved from right to left.

Defiant Control Settings

(Refer to Figure 27, Page 19)

Burn Rate	Primary Air Control
Low	From far right to 1/3 the distance to left
Medium	From 1/3 to 2/3 the distance to left
High	From 2/3 the distance to left, to far left

High-Efficiency Wood Burning with Catalytic Combustion

A Defiant leaves the factory with the combustor installed.

In the United States, it is against the law to operate this wood heater in a manner inconsistent with operating instructions in this manual, or if the catalytic combustor is deactivated or removed. The components of the catalytic combustion system in your Defiant work together to produce optimum conditions for secondary combustion.

When the damper is closed, smoke travels through the catalytic element, which causes ignition of smoke at temperatures of 500°-600° F (260°-315°C), half the temperature normally required for unaided secondary combustion.

The catalytic element is a ceramic "honeycomb" coated with the catalytic material. The element is located in the secondary combustion chamber, molded from a special high-temperature insulating refractory material. The chamber provides the correct environment necessary for secondary combustion of the fuel (smoke).

Closing the damper exposes the smoke to the combustor. If the combustor is at least 600°F (315°C), it will begin to burn the smoke.

Closing the stove damper may also reduce the draft, so to avoid putting out the fire or deactivating the combustor, close the damper only when a fire is well-established and the chimney is thoroughly warmed. When starting a fire, wait until the fire is well established and there is an ember bed of at least 3-4 inches before closing the damper.

Never kindle a fire with colored paper or paper that has colored ink or a glossy surface, and never burn treated wood, garbage, solvents, or trash. All of these may poison the catalyst and prevent it from operating properly. Never burn cardboard or loose paper except for kindling purposes. Never burn coal; doing so can produce soot or large flakes of char or fly ash that can coat the combustor and cause smoke to spill into the room. Coal smoke also can poison the catalyst so that it won't operate properly.

In general, the fire must be sufficiently well-established to ensure that catalytic activity is initiated. When first starting a fire, a medium- to high- firing rate must be maintained until the stove, catalyst, and fuel are all stabilized at the proper operating temperatures, and the chimney is warmed.

Even though it is possible for the fire to get quite hot within a few minutes after a fire is started, the combustor may stop working or the fire may go out if the fire dies down immediately as a result of the damper being closed. Once the combustor starts working, heat generated by burning the smoke will keep it working.

To determine whether the combustor is operating, observe the amount of smoke leaving the chimney when the damper is activated and when it is not. This procedure is described on Page 30.

Avoid using a full load of very dry wood in the firebox. This may result in continuous very high temperatures in the secondary combustion area and damage the combustor. Wood which has been split, and stored under cover for more than 18 months may be considered very dry. If you must burn extra-dry wood, mix it with greener wood for a longer fire and less stress on the combustor. Also, do not use a full load of dry slab wood or scrap wood. For long burns, use a mix of dry and moderately dry wood.

Conditioning Your Stove

Cast iron is extremely strong, but it can be broken with a sharp blow from a hammer or from the thermal shock of rapid and extreme temperature change.

The cast plates expand and contract with changes in temperature. When you first begin using your Defiant, minimize thermal stress by letting the plates adjust gradually during three or four initial break-in fires following Steps 1-3 below.

Starting and Maintaining a Wood Fire

Burn only solid wood in the Defiant, and burn it directly on the grate. Do not elevate the fuel. Do not burn coal or other fuels.

The damper must be open when starting a fire or when refueling.

Do not use chemicals or fluids to start the fire. Do not burn garbage or flammable fluids such as gasoline, naphtha, or engine oil.

1. Open the stove damper, and open the primary air control fully.
2. Place several sheets of crumpled newspaper in the stove. Do NOT use glossy advertisements or colored paper, as they can poison the catalyst. Place on the paper six or eight pieces of dry kindling split to a finger-width size, and on the kindling lay two or three larger sticks of split dry wood approximately 1-2" (25-50 mm) in diameter. (Fig. 33)

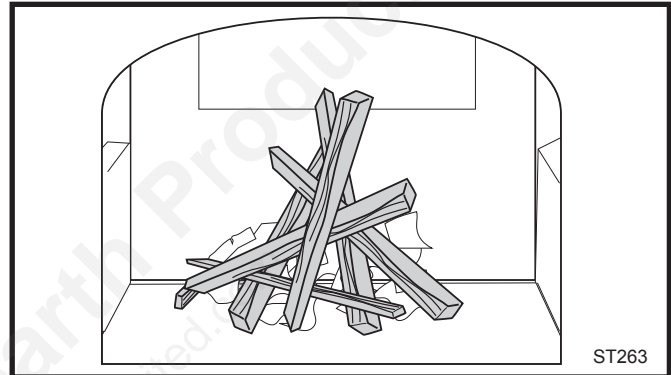

Fig. 33 Start the fire with newspaper and dry kindling.

Also, never use gasoline-type lantern fuel, kerosene, charcoal lighter fluid, or similar liquids to start or "freshen up" a fire. Keep all such liquids well away from the Defiant while it is in use.

3. Light the newspaper and close the door. Gradually build up the fire by adding a few 3-5" (80-120 mm) diameter splits. **If this is one of the first few "break-in" fires, let the fire burn brightly, and then let it die out.**

During the break-in fires, do not let the stove get hotter than 500°F. (260°C) as measured on an optional stove-top thermometer. Adjust the air control lever as necessary to control the fire.

Some odor from the stove's hot metal, the paint, and the cement is normal for the first few fires.

NOTE: Some chimneys must be "primed," or warmed up, before they will draw sufficiently to start a fire. To correct this situation, roll up a couple pieces of newspaper, place them on top of the kindling and toward the back of the stove, light them, and close the doors. This will encourage the smoke to rise rapidly, making it easier to establish a good draft.

Once the draft is established, open the front door and light the rest of the fuel from the bottom. Do not light the main bed of fuel until the chimney begins drawing, and repeat the procedure as often as necessary if the initial attempt is unsuccessful.

4. If your Defiant has been broken-in previously using Steps 1-3, continue to build the fire gradually. Add larger wood with a diameter of 3-4" (75-100 mm). Continue adding split logs of this size to the briskly-burning fire until there is a glowing ember bed at least 3" (75 mm) deep. (Fig. 34) A good ember bed is necessary for proper functioning of the catalytic system and may take an hour or more to establish.

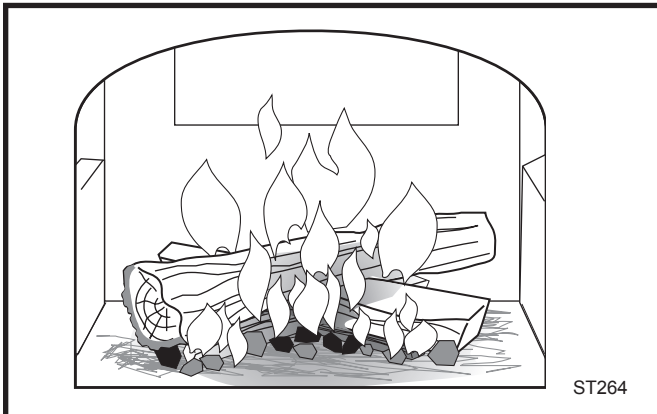

Fig. 34 Add larger pieces of wood as the fire begins to burn well.

5. Close the damper when the griddle temperature reaches 450°F (230°C).

6. Adjust the air control for your desired heat output.

NOTE: Stove installations vary widely, and the operating guidance given here is only a starting point. The draft management information on Page 26 will explain in detail how the features of your installation may help or hinder good draft, and how you may need to vary your firing technique if your installation doesn't encourage a good draft.

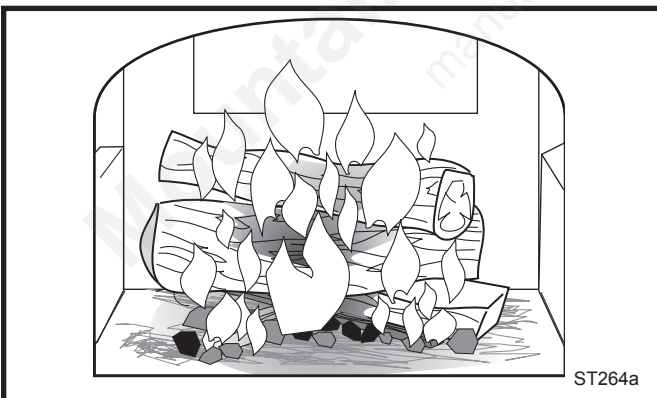

Fig. 35 Add full size logs after the ember bed is 3" (75mm) deep.

Refuel While the Embers Are Still Hot

When reloading, best results will be achieved if you first de-ash the stove by stirring the fuel bed to allow ash to fall through the grate into the ash pan.

Do not break the charcoal into very small pieces or pound or compress the charcoal bed.

It is important that air can circulate through the charcoal bed during the burn. Larger pieces of charcoal allow more air to circulate under the wood, resulting in the fire reviving more quickly. (Fig. 35)

For best results when refueling, wear long-cuffed stove gloves to protect your hands and forearms, add fuel while the stove still has plenty of glowing embers to re-ignite the fire, and include some smaller pieces of wood in the new fuel load to help the stove regain its operating temperature quickly. Use this sequence as a guide to successful refueling:

1. Open the damper.
2. De-ash the stove as described above. Open the ashdoor and check the level of ash in the ash pan. Empty the pan if necessary and replace it in the stove. Close the ash door.
3. Open the griddle, load the wood (smaller pieces first), and close the griddle.
4. Close the damper.
5. When the surface temperature reaches 450°F. (230°C), adjust the air control for the amount of heat you desire.

NOTE: If the remaining charcoal bed is relatively thick and if your fuel is well seasoned, it is possible to add fresh fuel (smaller pieces first), close the door and damper, and reset the primary air thermostat for the desired heat output.

WARNING: Operate your Defiant only with the doors either fully open or fully closed.

CAUTION: The Defiant will be hot while in operation. Keep children, clothing and furniture away. Contact may cause skin burns.

DO NOT OVERFIRE THIS HEATER. Overfiring may cause a house fire, or can result in permanent damage to the stove and to the catalytic combustor. If any part of the Defiant other than the baffle and/or catalytic combustor glows, you are overfiring.

The throat is made of a special cast iron which can withstand higher temperatures than most other parts of your stove. It protects the catalytic element from direct flame impingement, which can shorten the catalyst's life. Since the throat is in the direct path of flame between the firebox and the catalyst, it reaches higher temperatures than other firebox parts, and it may glow at times. If it does glow, you will see this directly through the front doors. The glow is normal and does not indicate a problem.

At times you may see a glow from the catalyst shining through the ports of the throat. This is also normal and does not indicate a problem. The catalytic element,

located below and behind the throat, can glow at high temperatures. This is also normal. However, the element can be active and operate properly without glowing. The lack of a glow does not indicate that the catalyst isn't working. Note that the catalyst is most likely to glow at its higher temperatures, which it reaches when the firebox is in its lower range - the catalyst is an after-burner, and the more waste fuel there is in the smoke, the hotter the catalyst gets.

We strongly advise the use of a stove-top thermometer as a guide to stove performance. Normal operating temperatures are between 450°F (220°C) and 700°F (370°C). Lower temperatures can indicate incomplete combustion and weak draft; higher temperatures can shorten the life of the castings.

Ash Disposal

Routine ash removal is important for ease of maintenance, and is important for the stove's durability. Remove ash before it reaches the top of the ash pan. Check the level at least once a day. Every few days, clear any ash from the outer edges of the firebox. Most of the ash will fall through the grate. Slice or stir the ash with a shovel or poker so that it falls through the grate slots.

IMPORTANT: Check the level of ash in the ash pan before reloading the stove. If the ash level is close to the top edge of the pan, empty the pan according to this procedure:

- Open the damper.
- Open the griddle or front doors, and use a shovel or poker to stir excess ash through the ash slots in the grate down into the ash pan.
- Close the griddle or doors, and unlatch the ash door. (Fig. 36) It will pivot, swinging the ash pan out of the stove.
- Slide the cover onto the pan, making sure it is securely closed. (Fig. 37)

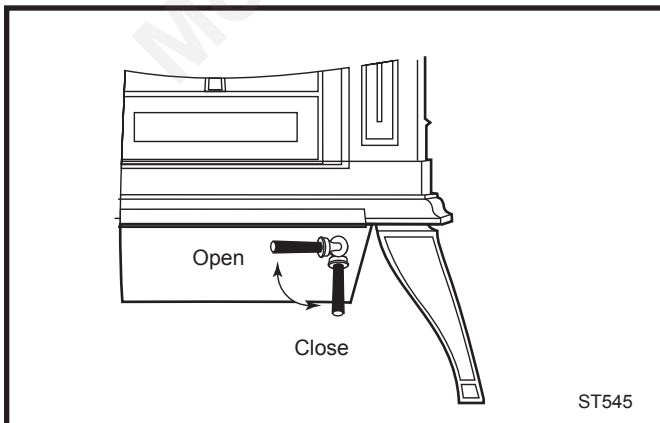

Fig. 36 Turn the ashdoor handle clockwise to open and counterclockwise to close.

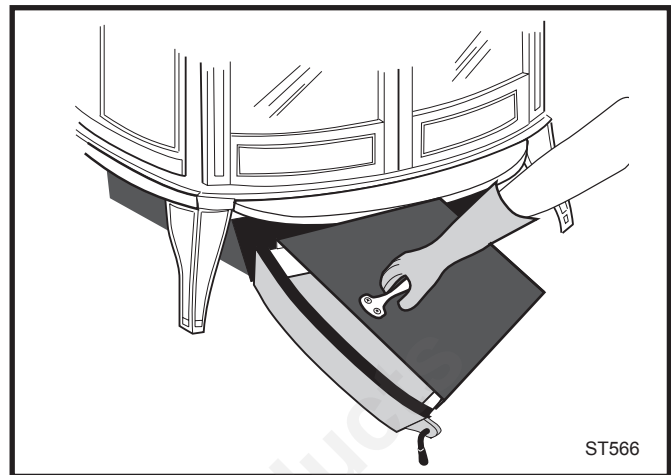

Fig. 37 Be sure the cover is securely attached before removing the ash pan.

- Remove the ash pan, making sure to keep it level.
- To keep the cover from sliding off and to keep ash from falling on the floor, do not tilt the ash pan forward.
- If the stove is in operation, close the ash door while disposing of the ash. You may need to lift the latch end of the door slightly to align the latch with the mating part on the stove bottom.
- Properly dispose of the ash in a metal container with a tight-fitting lid. Store the container outdoors away from all combustible material.
- Return the ash pan to its original position in the stove, and close and latch the ash door. (Fig. 37)
- Do not operate the stove with the ash door open. This will result in over-firing, and could cause damage to the stove, void the warranty, or even lead to a house fire.

Empty the ash pan regularly, typically every one to three days. The frequency will vary depending on how you operate your Defiant: ash will accumulate faster at higher heat outputs.

Remove ash frequently and place it outdoors in a metal container with a tight-fitting lid. Place the closed container of ash on a noncombustible floor or on the ground, well away from all combustible materials, pending final disposal. If the ash is disposed of by burial in soil or otherwise locally dispersed, it should be kept in the closed container until all cinders have thoroughly cooled.

You can use wood ash as a garden fertilizer.

CAUTION: Never use your household or shop vacuum cleaner to remove ash from the stove; always remove and dispose of the ash properly.

Draft Management

A stove is part of a system, which includes the chimney, the operator, the fuel, and the home. The other parts of the system will affect how well the stove works. When there is a good match between all the parts, the system works well.

Wood stove or insert operation depends on natural (unforced) draft. Natural draft occurs when the smoke is hotter (and therefore lighter) than the outdoor air at the top of the chimney. The bigger the temperature difference, the stronger the draft. As the smoke rises from the chimney it provides suction or 'draw' that pulls air into the stove for combustion. A slow, lazy fire with the stove's air inlets fully open indicates a weak draft. A brisk fire, supported only by air entering the stove through the normal inlets, indicates a good draft. The stove's air inlets are passive; they regulate how much air can enter the stove, but they don't move air into it.

Depending on the features of your installation - steel or masonry chimney, inside or outside the house, matched to the stove's outlet or oversized - your system may warm up quickly, or it may take a while to warm up and operate well. With an 'airtight' stove, one which restricts the amount of air getting into the firebox, the chimney must keep the smoke warm all the way to the outdoors in order for the stove to work well. Some chimneys do this better than others. Here's a list of features and their effects.

Masonry Chimney

Masonry is a traditional material for chimneys, but it can perform poorly when it serves an 'airtight' stove. Masonry is a very effective 'heat sink' - it absorbs a lot of heat. It can cool the smoke enough to diminish draft. The bigger the chimney, the longer it takes to warm up. It's often very difficult to warm up an outdoor masonry chimney, especially an oversized one, and keep it warm enough to maintain an adequate draft.

Steel Chimney

Most factory-made steel chimneys have a layer of insulation around the inner flue. This insulation keeps the smoke warm. The insulation is less dense than masonry, so a steel chimney warms up more quickly than a masonry chimney. Steel doesn't have the good looks of masonry, but it performs much better.

Indoor/Outdoor Location

Because the chimney must keep the smoke warm, it's best to locate it inside the house. This uses the house as insulation for the flue and allows some heat release into the home. An indoor chimney won't lose its heat to the outdoors, so it takes less heat from the stove to heat it up and keep it warm.

Chimney Height

The common wisdom tells us that a taller flue draws better than a short one. This isn't necessarily so. If a chimney is tall enough to meet the safety requirements of the 2/3/10 foot rule, then adding more height isn't the right answer to a draft problem. In fact it could make the problem worse, by adding more mass to the chimney system, which the smoke must warm up, at the far end from the heat source (the stove). Don't make a chimney taller unless you must to meet the safety rules, or unless there's some nearby feature causing a downdraft. Even then, there are downdraft-preventing chimney caps available, which are probably the smarter choice.

Flue Sizing

The inside size of a chimney for an 'airtight' stove should match the size of the stove's flue outlet. When a chimney serves an airtight stove, more is not better; in fact, it can be a disadvantage. Hot gases lose heat through expansion; if we vent a stove with a six-inch flue collar (28 square inch area) into a 10 x 10" flue, the gases expand to over three times their original size. This cools the gases, which weakens draft strength. If an oversized flue is also outside the house, the heat it absorbs gets transferred to the outdoor air and the flue usually stays cool.

It's common for a masonry flue, especially one serving a fireplace, to be oversized for the stove. It can take quite a while to warm up such a flue, and the results can be disappointing. The best solution to an oversized flue is an insulated steel chimney liner, the same diameter as the stove or insert's flue outlet; the liner keeps the smoke warm, and the result is a stronger draft. An uninsulated liner is a second choice - the liner keeps the smoke restricted to its original size, but the smoke still must warm up the air around the liner. This makes the warm-up process take longer.

Pipe & Chimney Layout

Every turn the smoke must take as it travels to the chimney top will slow it down. The ideal pipe and chimney layout is straight up from the stove, to a completely straight chimney. If you're starting from scratch, use this layout if possible. If the stovepipe must elbow to enter a chimney, locate the thimble about midway between the stove top and the ceiling. This achieves several goals: it lets the smoke speed up before it must turn, it leaves some pipe in the room for heat transfer, and it gives you long-term flexibility for installing a different stove without relocating the thimble.

There should be no more than eight feet of single-wall stove pipe between the stove and a chimney; longer runs can cool the smoke enough to cause draft and creosote problems. With prefabricated chimney, bring it down to six to eight feet from the stove. With a masonry chimney, arrange the pipe layout to elbow into the chimney within eight feet of the stove.

Single Venting

Each 'airtight' stove requires its own flue. If an airtight stove is vented to a flue that also serves an open fireplace, or a leakier stove, it's easier for the chimney draft to pull air in through those channels than it is to pull air through the airtight, and performance suffers. Imagine a vacuum cleaner with a hole in the hose to see the effect here. In some cases the other appliance can even cause a negative draft through the airtight, and result in a dangerous draft reversal.

Creosote

Creosote is a by-product of slow wood-burning. It's an organic tar that can condense in the flue if it's dense in the smoke, and slow-moving, and cools off to less than 290°F (130°C). Condensed creosote is volatile, and can generate chimney fires if it gets hot enough. All the features that affect chimney draft also affect creosote condensation - so use whatever combination of installation features and operational steps will encourage good draft and minimize creosote production.

Because letting the smoke cool off and slow down is one of the keys to creosote production, it makes sense to line a chimney to match the stove's outlet size, for safety reasons as well as performance. Canadian law requires a matching liner to serve any stove or insert vented through a fireplace chimney; in the US, the National Fire Protection Association recommends one if the flue is more than three times bigger (in square area) than the outlet on the stove or insert. Some localities enforce the NFPA guidelines as part of their building codes.

Fuel

Even the best stove installation will not perform well with poor fuel. The best fuel is hardwood that has air-dried 12-18 months. Softwood burns, but not as long as hardwood. Fairly 'green' wood has a lot of moisture in it; it will burn, but some of the heat potential is used to drive the remaining moisture off the wood. This reduces the amount of heat that reaches your home and can contribute to a creosote problem. There are moisture meters available for firewood; you can also judge your wood by its appearance and weight. If you get it green, lift a piece and get a sense of its weight; it can lose a third or more of its weight as it dries. Also look at the

ends of a log; as it dries it shrinks and often cracks. The more weathered and cracked a piece is, the drier it is.

Dry wood burns readily with a good chimney draft. But with modern stoves, especially catalytic ones, the wood can be too dry. While extra-dry wood has little creosote in it, the remainder can 'gas out' from the wood quickly and densely enough to overload the catalytic burner. If you hear a rumbling or roaring noise, like a propane torch, from the stove, that is a sign that the catalyst is seriously overfiring. The catalyst is a platinum film on a ceramic base; the metal can get to higher temperatures than the ceramic can take, and overfiring the catalyst can break it. Dry wood can also burn out faster than you want. If your dry wood burns out too quickly or overloads the catalyst you can mix in greener wood to slow the fire down.

Back-puffing

Back-puffing results when the fire produces volatile gases faster than the chimney draft pulls them out of the firebox. The gases back up in the firebox till they're dense enough and hot enough to ignite. If your stove back-puffs, you should open up the damper to let the smoke rise to the flue more quickly, let more air into the firebox, and avoid big loads of firewood. You should always see lively, dancing flames in the firebox; a lazy, smoky fire is inefficient and can contribute to creosote buildup in the chimney.

Draft Testing

An easy way to test your chimney draft is to close the stove's damper, wait a few minutes to let the airflow stabilize, then see whether you can vary the strength of the fire by swinging the air control open and closed. Results are not always instant; you may need to wait a few minutes for a change in the air control setting to have an effect on the fire. If there's no change, then the draft isn't strong enough yet to let you close the damper, and you'll need to open it for a while longer and manage the fire with the air inlet until the draft strengthens. If you keep track of your burning habits and relate them to their effects on the stove's operation, you'll be rewarded with good performance and a safe system.

Negative Pressure

Good draft also depends on a supply of air to the stove; a chimney can't pull in more air than is available to it. Sluggish draft results when a house is tight enough to prevent the ready flow of air to the stove, or by competition between the stove and other equipment that sends indoor air outside - especially power-driven equipment like range hoods, clothes dryers, etc. If the chimney draws well with all other equipment turned off (or sealed, in the case of fireplaces and/or other stoves), then you simply need to be careful with timing the use of the other gear. If you need to crack a nearby window or door to enable the chimney to pull well, that's a sign that you should install an outside-air intake to bring combustion air directly to the stove. An outside air adapter will attach to the stove to connect an air duct for outdoor combustion air.

Conclusion

Wood-burning is an art rather than a science. Once the stove and chimney system are in place, you can only vary your technique, mostly your timing, to achieve good results. If you keep track of your burning habits and relate them to their effects on the stove's operation, you'll be rewarded with good performance and a safe system.

Maintenance

Keep Your Stove Looking New and Working Its Best

Let the fire in the stove go out and allow the stove to cool completely before beginning any maintenance procedure.

Care of the Cast Iron Surface

An occasional dusting with a dry rag will keep the painted cast iron of your Defiant looking new.

The stove's paint can be touched up as needed. First, mask the areas, such as enamelled parts, glass, or handles, around the spot to be painted. Clean the spot with a wire brush. Remove the griddle and set it aside. It is normal for the griddle to darken after use. You can clean it with a fine-bristle wire brush, or steel wool.

Then, touch up the stove with Vermont Castings' high temperature stove paint. Apply the paint sparingly; two light coats of paint are better than a single heavy one.

Care of the Porcelain Enamel Surface

Use a dry or slightly damp rag or soft brush to remove spills or stains. For difficult jobs that require a cleaning agent, use only a kitchen appliance cleaner or polish recommended for use on enamel surfaces.

Cleaning the Glass

Most of the carbon deposits on the glass will burn off during hot fires.

However, the ash residue that accumulates on the glass surface should be removed regularly to prevent etching. To clean the glass, follow this procedure:

- Be sure the glass is completely cool.
- Clean the glass with water or a cleaner made especially for this purpose. Do not use abrasive cleaners. Use cleaning agents sparingly and be sure to keep them off the outer surfaces of the stove.
- Rinse the glass thoroughly.
- Dry the glass completely.

Replace Broken Glass Immediately

Do not operate your stove if the glass in the doors is damaged.

If you need to replace the glass, use only the high temperature ceramic glass supplied by Vermont Castings. Do not use substitutes. Be sure to specify left or right glass; the panels are not interchangeable, due to a heat-reflective coating on the side toward the room.

Removing the Glass

1. Remove the right and left door assemblies by raising the door until the lower hinge pin clears its hole; then, angle the door bottom slightly outward and pull down to release the upper hinge pin. Place the doors face down on a padded work surface. Be especially careful with enamelled doors.
2. Remove the screws that hold the glass retainer clips in place, and remove the clips.
3. Carefully lift the broken glass panel from the door.

Installing the Glass

Check the gasket around the window; it should be soft and resilient so that the glass will seal properly against the door. Replace the gasket if it has hardened or if it is compressed.

1. Center the glass on the gasket. Be sure to place the glass so that the infrared reflective coating is on the exterior side, facing toward the room.
2. Secure the glass on both doors with the retainer clips. Tighten all screws. (Fig. 38)
3. Replace the doors on the stove.
4. Open and close the doors to check that they fit and work properly. Adjust as necessary.

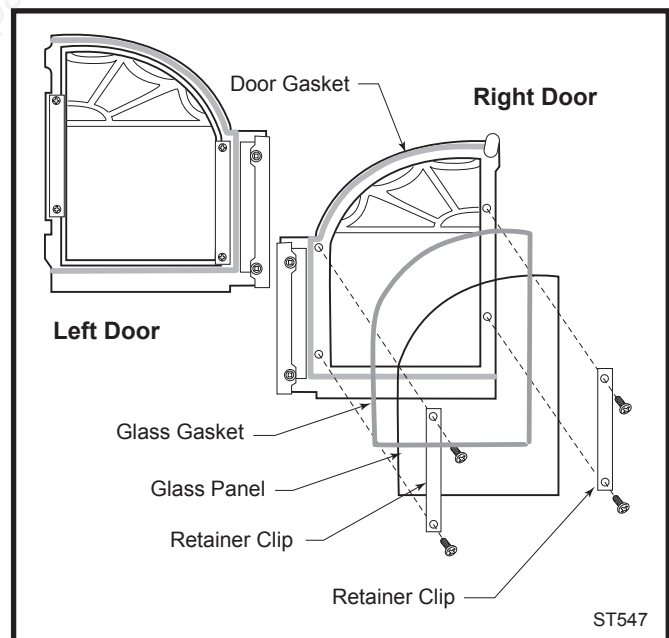

Fig. 38 An exploded view of the glass assembly.

Check the Operation of the Primary Air Shutter

The primary air shutter is at the back of the ash drop and is visible from the back of the stove. (Fig. 39) The shutter must open and close freely when you move the thermostat lever. If it doesn't, remove any obstruction. If you need assistance, consult your local Vermont Castings Authorized Dealer.

Do not change the adjustment of the cable in an attempt to gain increased firing. The air shutter controls how much air can enter the stove, but chimney draft is the force that pulls air into the stove. If changing the thermostat handle position does not lead to changes in the fire's intensity within four or five minutes, it's probably due to weak chimney draft (in the case of a weak fire you can't increase) or an air leak in the stove (in the case of a fire you can't decrease).

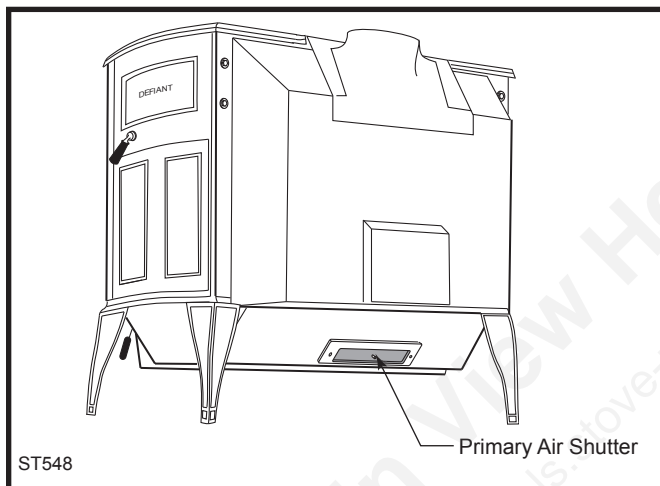

Fig. 39 The primary air shutter must move freely.

Adjust the Damper as Needed

The tension on the Defiant's damper is adjustable to compensate for compression of the gasket that seals the damper to the upper fireback. To adjust the damper:

1. Remove the griddle. Loosen the lock nut at the center of the damper. (Fig. 40)
2. Turn the pressure screw approximately one half turn clockwise with an Allen wrench provided with your stove.
3. Tighten the lock nut. Prevent the pressure screw from turning as you tighten the nut. Re-test the damper.

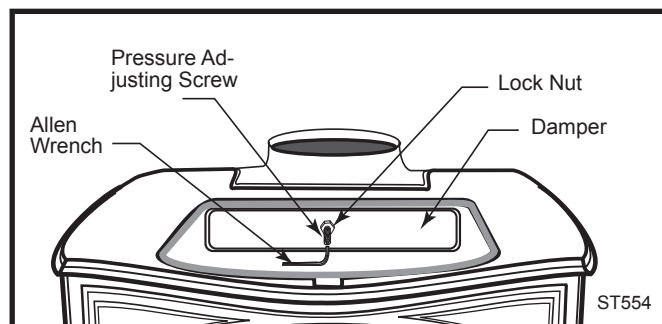

Fig. 40 Adjust the damper with the Allen wrench.

Tighten the Damper Handle as Needed

A handle on the left side of the stove controls the damper. The handle attaches to the damper rod with a set screw. Periodically check the set screw and tighten as necessary.

How to Adjust the Door Latches

The Defiant's doors should close securely to prevent accidental opening and to keep air from leaking into the stove. On adequately adjusted doors, the handles should resist slightly as they are turned to the closed position and the doors themselves should be drawn slightly toward the stove.

Over time, the gasket around the doors will compress and the latches may need adjustment.

To adjust the latches, loosen the small lock nut, rotate the striker screw a half-turn, and re-tighten the small lock nut. (Fig. 41) Your stove kit includes an Allen wrench for latch adjustments. Hold the striker screw to keep it from turning as you tighten the lock nut. Make repeated small adjustments until the setting is right.

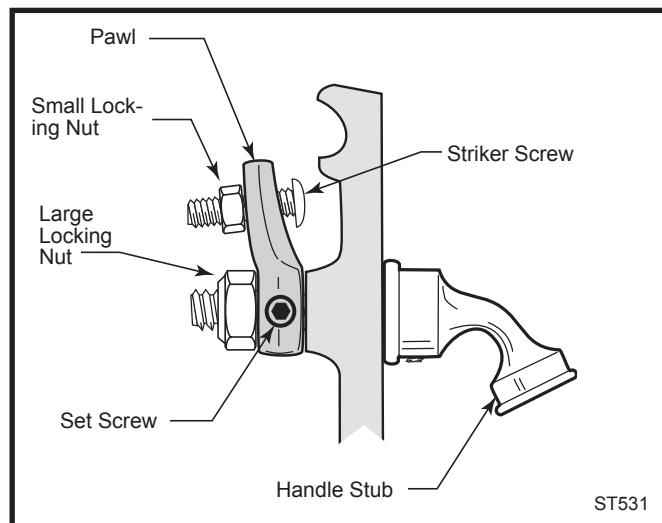

Fig. 41 Turn the door latch striker screw in or out to tighten or loosen the screw.

The Catalytic Element

This wood heater contains a catalytic combustor, which needs periodic inspection and replacement for proper operation. In the United States it is against the law to operate this wood heater in a manner inconsistent with the operating instructions in this manual, or if the catalytic element is deactivated or removed.

Under normal operating conditions, the catalytic combustor should remain active for two to six years (depending on the amount of wood burned). However, it is important to monitor the combustor periodically to ensure that it is functioning properly, as well as to determine when it needs to be replaced. A non-functioning combustor will result in a loss of heating efficiency, and an increase in creosote and emissions.

Inspection and Cleaning

Inspect the combustor “in place” for fly ash accumulation and physical damage three times per year. Clean the combustor as needed. Do not remove the combustor unless a more detailed inspection is warranted because of diminished performance as outlined in the next section.

The refractory package that houses the catalytic combustor should be inspected annually for a buildup of fly ash and cleaned if necessary. This may be done when you examine the combustor.

When to Suspect a Combustor Problem

The best way to evaluate the performance of your Defiant’s combustor is to observe the amount of smoke leaving the chimney — both when the combustor has “lighted-off” and when it has not. Follow these steps:

- With a fire going and the combustor properly activated, with the damper closed to route smoke through it as described in the Operation Section, go outside and observe the smoke leaving the chimney.
- Then, open the stove damper and once again check the smoke leaving the chimney.

You should see significantly more smoke when the stove damper is open and exhaust does not pass through the combustor. However, be careful not to confuse smoke with steam from wet wood. Steam dissipates in the air quickly; smoke does not.

If this test indicates a problem, consider other possible factors as well, such as the weather or a change in the quality of your fuel. In warm weather, draft is weaker than it is in colder winter weather, and fires can burn sluggishly. Small, hot fires are a good solution under these conditions.

Burning “green” (insufficiently seasoned) wood will result in poorer performance than burning properly seasoned fuel. You may have to run your stove hotter (more air) to achieve acceptable performance using green or wet wood.

Also, consider any changes in your operating routine.

Once you have ruled out any other possible causes for a decline in performance, inspect and clean the combustor if necessary. Be sure to protect any surface you use for setting the stove parts aside.

Inspecting the Combustor

1. Lift the throat off its support brackets, and then remove it from the stove and place it on a protected surface. (Fig. 42)
2. Use a flashlight, and a mirror if necessary, to examine the combustor. If no fly ash or damage is visible, the inspection is complete and you may replace the baffle. If closer examination or cleaning is needed, go to the next section.

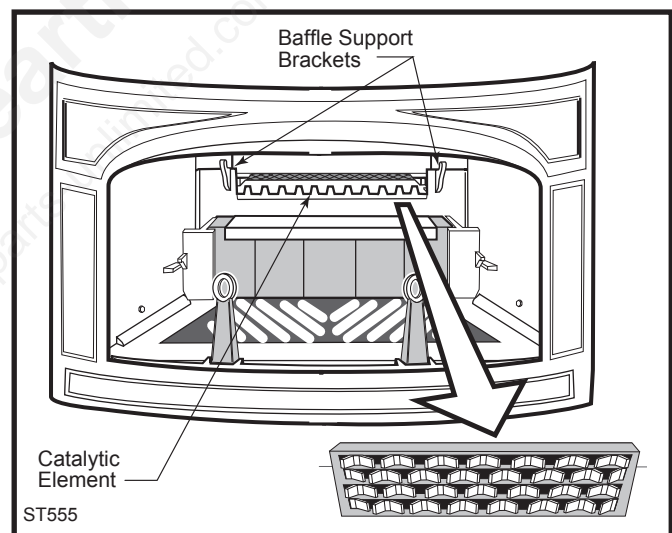

Fig. 42 Lift the baffle off its supports to inspect the catalyst.

Removing and Cleaning the Combustor

1. Remove the firebricks. Lift off the steel clip and remove the bricks individually. (Fig. 43)
2. Tap the left and right wedges upward, and remove the lower fireback by pulling it forward. You can either let it lie face down on the firebox floor, or remove it from the stove, through the front door opening. (Fig. 44)

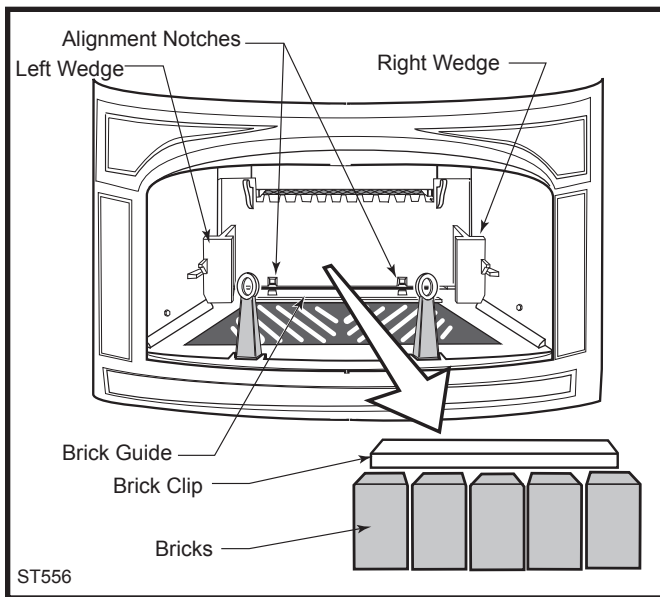

Fig. 43 Remove the bricks and the brick retainer.

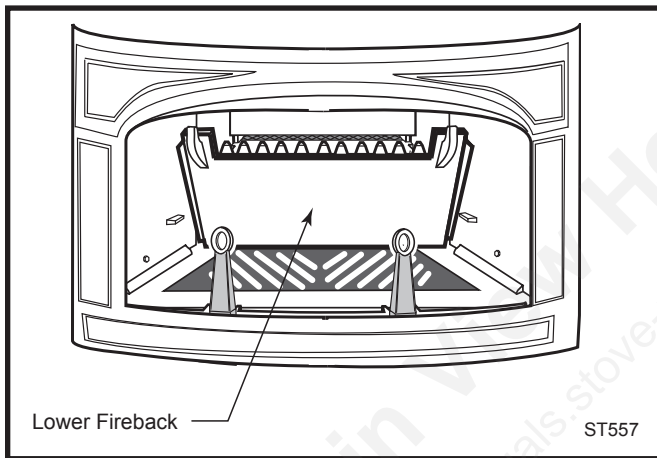

Fig. 44 Remove the lower fireback.

3. Carefully remove the catalytic combustor's refractory access cover, then remove the combustor. The refractory material is brittle; handle it carefully. (Fig. 45)
4. Check the combustor's honeycomb-like element for a buildup of fly ash. If any is evident, take the combustor outside and clean it by blowing air gently through it. Do not push anything through the honeycomb; do not use compressed air to clear the passages. Such abrasion can scrape the thin coating of platinum (the catalyst) off the ceramic base, shortening the catalyst's life and reducing its effectiveness.

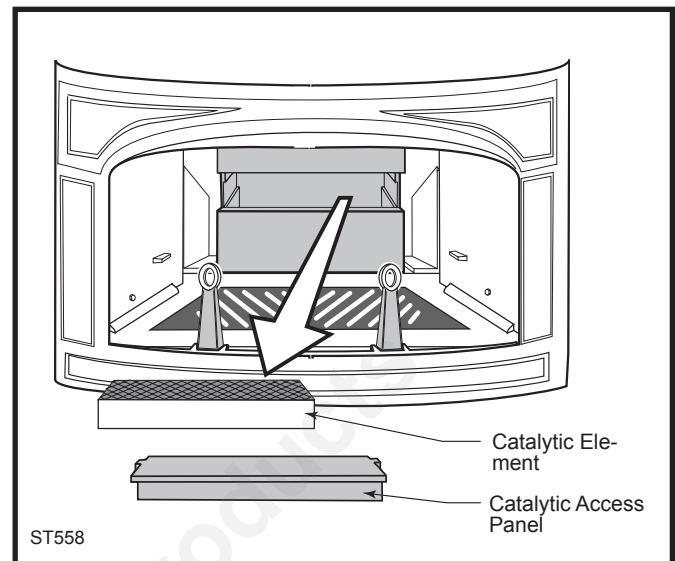

Fig. 45 Remove and inspect the catalytic element.

5. Inspect the element for damage or degradation. Although small hairline cracks will not affect performance, the element should be essentially intact. If the element is broken in pieces or has sections missing, it should be replaced. Call your local Vermont Castings Authorized Dealer for a replacement element.

While the catalytic element is removed, check the condition of the secondary air probe. Use an inspection mirror to locate the probe within the combustion chamber. (Fig. 46) The probe should extend 1" to 1½" into the chamber and show no signs of excessive deterioration, such as warping, corrosion, or short length. A damaged secondary air probe can affect catalytic performance. If the probe needs replacement, contact your local dealer.

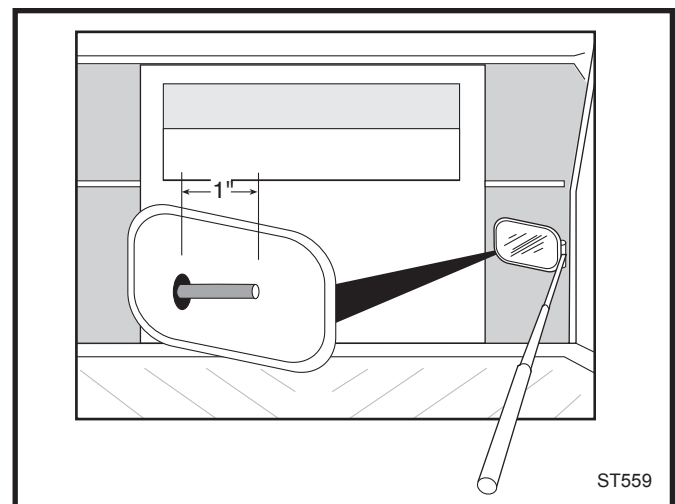

Fig. 46 Use an inspection mirror to check the reflected view of the secondary probe.

6. If the element is in good condition and clean, re-install it in the stove and replace the refractory access cover.
7. Replace the fireback, the five bricks and their clip, the left and right wedges, and the throat. When you install the lower fireback, be sure to align the two slight recesses in its bottom forward edge behind the mating tabs on the firebox floor. (Fig. 43) When you install the wedges, be sure to place their rear vertical edges against the outermost left and right edges of the lower fireback, to ensure a good seal between the lower fireback and the stove's outer back. Tap them downward to seat them snugly, but not overly tight.

8. Clean the chimney and chimney connector.

Operate the stove in your usual manner for two weeks, inspecting the chimney and the chimney connector frequently during this period.

If creosote does not build up as fast, it is likely that the performance change was caused by fly ash deposits on the catalytic element. However, continue the inspections of the chimney system for a few weeks to ensure that proper performance continues.

If you continue to find a significant creosote buildup or if you continue to see excessive smoke from the chimney, the catalytic element will need to be replaced. Contact your nearest Vermont Castings' Authorized Dealer for information about a replacement element.

NOTE: Use only the replacement catalyst supplied by a Vermont Castings dealer.

Replace the Stove Gaskets as Needed

Your Defiant uses fiberglass rope gaskets to make a tight seal between some parts. With use, particularly on moving parts, gaskets can become brittle and compressed and can begin to lose their effectiveness. These will need periodic replacement.

The sizes of replaceable gasket are listed below, along with their applications.

Gasket Diameter... ..And the Parts it Seals

- | | |
|-------|--|
| 5/16" | The griddle to the stove top (wire reinforced gasket) |
| 5/16" | The damper to the upper fireback; the front doors to the stove front; and the doors to each other. |
| 3/8" | The ash door to the front of the bottom panel |
| 3/16" | The outer glass panes to the door |

If you need to change a gasket, first obtain an appropriate replacement from your Vermont Castings, Authorized Dealer.

Wait until the fire is out and the stove has cooled. Be sure to follow the standard safety procedure for working with dusty materials: wear safety goggles and a dust mask.

The procedure for replacing gaskets is the same, regardless of the gasket location. Follow these eight steps:

1. Remove the existing gasket by grasping an end and pulling firmly. (Fig. 47)
2. Use a wire brush or the tip of a screwdriver to clean the channel of any remaining cement or bits of gasket. Remove stubborn deposits of cement with a cold chisel if necessary. (Fig. 47)

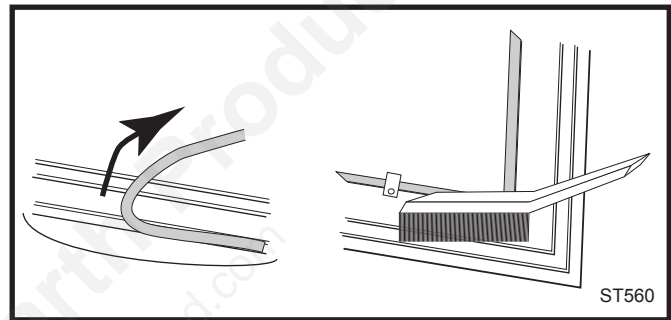

Fig. 47 Remove gasket then clean channel with wire brush.

3. Determine the correct length of the appropriate-sized gasket by laying it out in the channel. Allow an extra 1-2" (25-50 mm), and mark the spot to be cut.
4. Remove the gasket from the channel, place it on a wood cutting surface, and cut it at the marked spot with a utility knife.

Twist the ends slightly to keep the gasket from unraveling.

5. Lay an unbroken 1/8" (3 mm) bead of gasket cement in the newly-cleaned channel. (Fig. 48)
6. Starting at one end, press the gasket into the channel. (Fig. 48) Ensure a good joint where the gasket meets before trimming any excess. Do not overlap the gasket ends or leave ends with ragged edges.

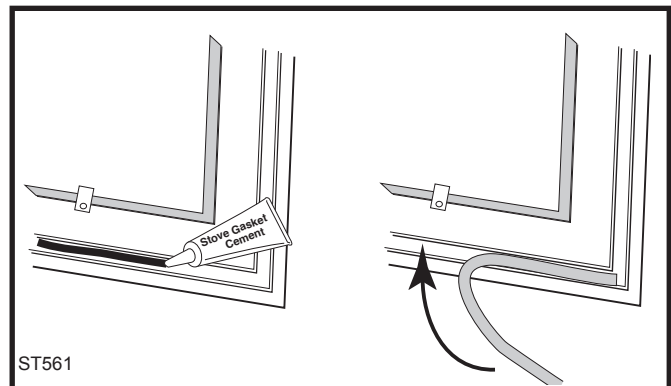

Fig. 48 Lay a bead of gasket cement then press gasket in place.

7. Press the gasketed part firmly against its normal mating surface to seat the gasket evenly in its channel. Close and latch the door to do this, or tap other parts with the rubber mallet (or hammer/block of wood).
8. Clean any excess cement from around the channel, then let the cement that holds the new gasket dry thoroughly.

Adjust the Door Latch If Necessary

The stove's doors may need adjustment after you have regasketed them. Initially, it may require loosening the latch to accommodate the new gasket; after a few weeks, it may need tightening to compensate for compression of the new gasket. The directions for adjusting the latches are on page 28.

Permanent Defiant Gaskets

Other gaskets form seals between non-moving parts, but these are not subject to the same wear and deterioration as gaskets on moving parts. It is unlikely that you will ever need to replace these gaskets unless the involved parts are disassembled and then put back together. If this is the case, the job should be done only by a qualified service technician.

5/16" diameter gasket seals the following parts:

- The lower fireback to the back panel
- The left and right air plates (inner sides)

The Chimney System

Creosote

Your Defiant is designed to reduce creosote build-up significantly. However, regular chimney inspection and maintenance must still be performed. For safety, good stove performance, and to protect your chimney and chimney connector, inspect your chimney and chimney connector on a regular schedule. Clean the system if necessary. Failure to keep the chimney and connector system clean can result in a serious chimney fire.

When wood is burned slowly, it produces tar, organic vapors and moisture that combine to form creosote. The creosote vapors condense in the relatively cool chimney flue of a slow-burning fire. As a result, creosote residue accumulates on the flue lining. When ignited, this creosote makes an extremely hot fire within the flue system that can damage the chimney and overheat adjacent combustible material. If a significant layer of creosote has accumulated —1/8" (3 mm) or more — it should be removed to reduce the risk of a chimney fire.

If you do experience a chimney fire, act promptly to:

- Close the damper and thermostat lever.
- Get everyone out of the house.
- Call the Fire Department.

Inspect the system every two weeks during the heating season as part of a regular maintenance schedule. To inspect the chimney, let the stove cool completely. Then, using a mirror and a strong light, sight up through the flue collar into the chimney flue. If you cannot inspect the flue system in this fashion, the stove must be disconnected to provide better viewing access.

Clean the chimney using a brush the same size and shape as the flue liner. Flexible fiberglass rods are used to run the brush up and down the liner, causing any deposits to fall to the bottom of the chimney where they can be removed through the clean-out door.

Clean the chimney connector by disconnecting the sections, taking them outside, and removing any deposits with a stiff wire brush. Reinstall the connector sections after cleaning, being sure to secure the joints between individual sections with sheet metal screws.

If you cannot inspect or clean the chimney yourself, contact your local Vermont Castings dealer or a professional chimney sweep.

Annual Maintenance

Every Spring, at the end of the heating season, perform a thorough cleaning, inspection and repair:

- Thoroughly clean the chimney and chimney connector.
- Inspect the chimney for damage and deterioration. Replace weak sections of prefabricated chimney. Have a mason make repairs to a masonry chimney.
- Inspect the chimney connector and replace any damaged sections.
- Check gasketing for wear or compression, and replace if necessary.
- Inspect and clean the catalytic element. Lightly clean the refractory assembly that houses the element but be careful not to damage the refractory material, which is very fragile.
- Clean the glass. Ash left on the glass can etch it, resulting in a chalky appearance. Also check for cracking; replace if needed.
- Check door and damper handles for tightness. Adjust if needed.
- Check heat shield screws. Tighten as necessary.
- Clean dust from the inner sides of bottom, rear and connector heat shields.
- Use a clean, dry, fine-bristle wire brush to remove any built-up accumulation on the top of the griddle. It is normal for the griddle to darken with use, and this is not treatable.
- Remove ashes from the ash pan and replace with moisture absorbing material (such as cat litter) to keep the stove interior dry.
- Touch up the paint on black stoves.

Appendix: Catalytic Combustor

In any chemical reaction, including the combustion process, there are certain conditions which must be met before the reaction can take place. For example, a reaction may require a certain temperature, or a certain concentration of the reactants (the combustion gases and oxygen), or a certain amount of time. Catalysts act at a molecular level to change these requirements, though they are not changed themselves during the reaction. In the Defiant's secondary combustion chamber the catalyst reduces the temperature at which secondary combustion can start from the 1000° - 1200° F. (540° - 650° C) range to the 500° - 600° F. (260° - 315° C) range, increasing efficiency, and reducing creosote and emissions.

The catalytic reaction does have some limitations of its own. Primary among these is that the reactants (the gases) come into close physical contact with the catalyst itself.

To ensure the necessary contact, the catalytic element in your Defiant is a ceramic base in the shape of a honeycomb. Each of the honeycomb's many surfaces carries a coating of the catalyst (usually a noble metal such as platinum or palladium). The large surface area exposed in this way ensures that the combustion gases have the greatest opportunity to come in contact with the catalyst.

Loss of catalytic activity will be apparent in several ways. First you may notice an increase in fuel consumption. Second, there will be a visible increase in the rate at which creosote builds up in your chimney connector system. You may also notice a heavy discharge of smoke from the chimney. There are a number of catalytic problems which can cause loss of activity:

Blockage

While the honeycomb pattern ensures good contact, it also increases the resistance to flow of the combustion gases, and, because of the many surfaces, provides more places for creosote and fly ash to deposit. It is important to follow the operating instructions in order to minimize these deposits, and to periodically inspect your catalyst for signs of blockage.

Masking and Poisoning

While the catalyst itself does not enter into the combustion process, certain elements, such as lead and sulfur, can attach to the active sites on the surface of the honeycomb. Though the catalyst is still there, it is covered, or masked, by the contaminant, and cannot function. To avoid this situation, it is important not to burn anything in your Defiant that is a source of these contaminants. Particularly avoid painted or treated wood, coal,

household trash, colored papers, metal foils, or plastics. Chemical chimney cleaners may also contain harmful elements. The safest approach is to burn only untreated, natural wood.

Flame Impingement

The catalytic element is not designed for exposure to direct flame. If you continually overfire your Defiant, the chemistry of the catalyst coating may be altered, inhibiting the combustion process. Do not use your Defiant with the baffle removed or damaged, as it shields the catalytic element from direct flame.

Thermal degradation of the ceramic base may also occur, causing the element to disintegrate. Stay within the recommended guidelines of the Operation section.

Overfiring

At low firing rates, especially with a large load of fuel, the catalytic element can become overloaded with gases which do not burn in the firebox. This puts increased strain on the catalytic element, causing it to operate near or even beyond the high end of its normal temperature range. An immediate sign of this is a low rumbling sound, or a sound like a small gas torch, coming from the stove's rear chamber. If you frequently hear such a sound, or continually see a bright glow through the baffle, open up the stove's primary air valve to make the fire burn more cleanly in the firebox, and cut back on the size of your firewood load. Essentially the catalyst is an afterburner, and will last longer under lighter loads.

Mechanical Damage

If the element is mishandled, damage may occur. Always treat the element carefully. Remember the catalyst is made of a ceramic material; treat it as you would fine china. Hairline cracks will not affect the performance of the catalyst, as long as the steel sleeve holds the element in the proper position.

Peeling

The surface coat may peel if the catalytic element is frequently subjected to excessive temperatures. Follow the operating instructions carefully to avoid this type of damage.

General

Every Vermont Castings' Defiant is equipped with either a Corning "Long-Life"® or an Applied Ceramics combustor. The products are equivalent.

If you must ship your catalytic element for any reason, remember its fragile nature. Place the element in a plastic bag, and package it with a generous amount of shock absorbing material.

Appendix: Chimney and Fireplace Hazards

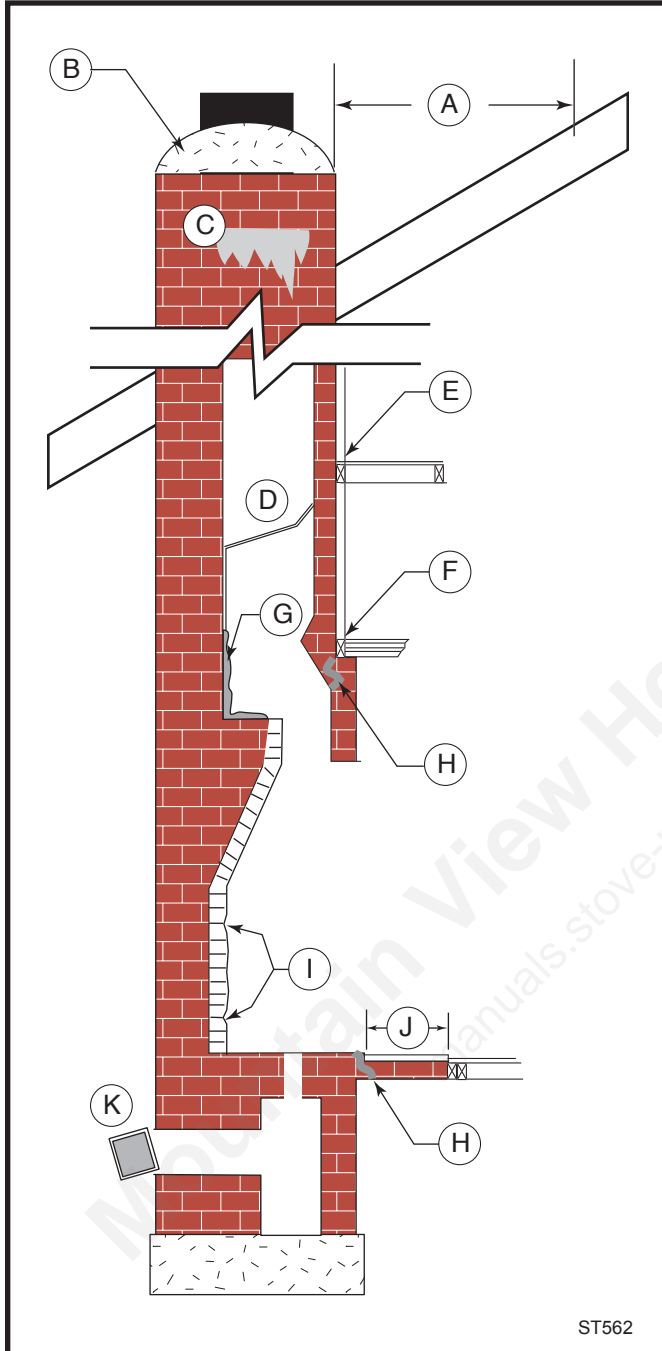

ST562

General -

- A. Improper chimney height. The top of the chimney must be at least 3 feet higher than the spot where it passes through or past the roof, or two feet higher than everything else within ten feet horizontally, whichever is higher.
- B. Deteriorated chimney cap
- C. Structural defects indicated by creosote stains on outside of chimney
- D. Blockage within chimney
- E. Improper clearance between chimney and nearby combustibles (less than 2" - check local codes)
- K. Loose or leaky cleanout door

For a fireplace -

- F. Improper clearance between smoke chamber and framing materials - (less than 2" - check local codes)
- G. Creosote buildup on smoke shelf
- H. Structural deterioration
- I. Loose or broken bricks or mortar
- J. Insufficient hearth depth. The hearth must extend 16" (18"/460mm in Canada) beyond the fireplace opening. With a fireplace insert, or a free-standing stove vented through a fireplace, the hearth must extend 16" (18"/460mm in Canada) beyond the front door opening of the stove or insert.

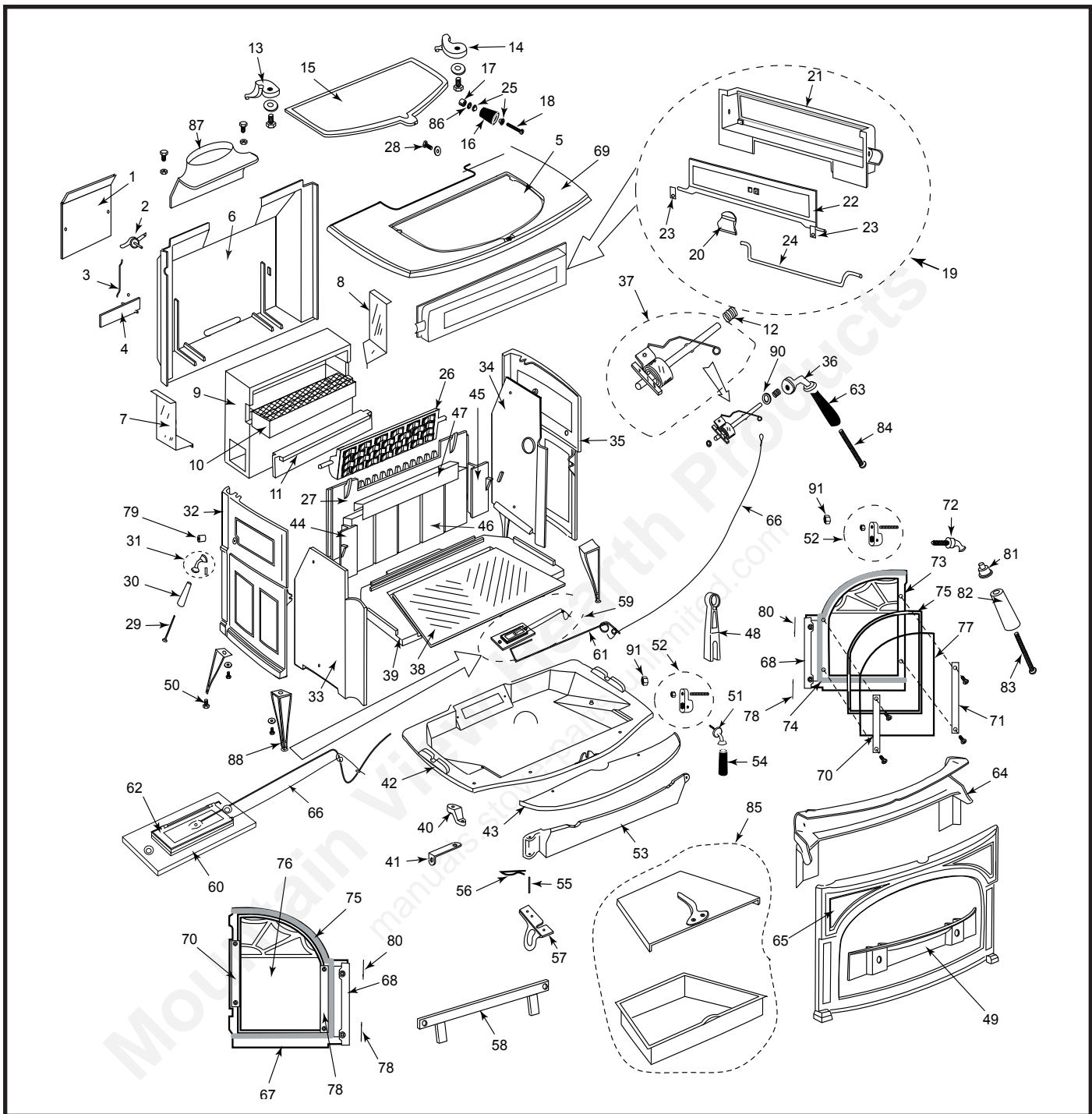

MHSC reserves the right to make changes in design, materials, specifications, prices and discontinue colors and products at any time, without notice.

Defiant Woodburning Stove Model 1945

Item Description	Part Number
1. Secondary Air Cover Plate	1601492
2. Secondary Air Probe Assy	1601489
3. Secondary Air Link	1601486
4. Secondary Air Flap	1601490
5. Griddle Gasket	1203668

Item Description	Part Number
6. Back	30001581
7. Left Heat Deflector	1608629
8. Right Heat Deflector	1608630
9. Refractory Assy (Body only)	1602512
10. Catalytic Combustor (Boxed)	30001152

Defiant Woodburning Stove Model 1945 (continued)

Item Description	Part Number
11. Refractory Access Panel	1602511
12. Thermostat Friction Spring	1201846
13. Left Griddle Quadrant	1301807
14. Right Griddle Quadrant	1301832
15. Griddle	1301641
16. Griddle Handle	1600657
17. Griddle Handle Spacer	1600070
18. Griddle Handle Bolt	1200907
19. Upper Fireback Assy	5000030
20. Damper Ramp ¹	1300643
21. Upper Firebrick ¹	1300633
22. Damper ¹	1300634
23. Damper Tab ¹	1601488
24. Damper Rod ¹	1600065
25. Griddle Handle Bushing	1201895
26. Throat Baffle	1300635
27. Lower Fireback	1300638
28. Upper Fireback Bolt	1201374
29. Damper Handle Screw	1201310
30. Damper Handle	1600664
31. Damper Handle Base Assy	30002720
32. Left Side	See Chart Pg. 38
33. Left Air Plate (Inner Side)	1300637
34. Right Air Plate (Inner Side)	1300636
35. Right Side	See Chart Pg. 38
36. Thermostat Handle Base Assy	30002716
37. Thermostat Assy	5005470
38. Grate	1300639
39. Primary Air Cover Plate	1300622
40. Top Ashdoor Hinge Support	30001689
41. Door Handle Holder	1600600
42. Bottom	30001577
43. Ashlip	See Chart Pg. 38
44. Left Side Wedge	1300628
45. Right Side Wedge	1300644
46. Firebrick (1¼" x 4½" x 9")	1601103
47. Firebrick Retainer	1600066
48. Andiron	1300646
49. Andiron Shelf	1300640
50. Leg Leveller	1201745
51. Ashdoor Handle Shaft	1600622
52. Door Latch Assy	5004025
53. Ashdoor	1300619
54. Ashdoor Handle (Wood)	1600663
55. Ashdoor Hinge Rod	30004028
56. Cotter Pin, Ashdoor	30001749
57. Ashdoor Bottom Hinge Support	1300642
58. Ashpan Bracket	30001908
59. Primary Air Valve Assy	5000024
60. Primary Air Frame ³	1307411
61. Primary Air Rod ³	1600058
62. Primary Air Valve ³	1307412

Item Description	Part Number
63. Thermostat Handle (Wood)	1600660
64. Airwash Manifold	1300627
65. Front	See Chart Pg. 38
66. Thermostat Cable	5005471
67. Left Door	See Chart Pg. 38
68. Door Hinge Strip	1300645
69. Top	See Chart Pg. 38
70. Glass Clip	30001715
71. Glass Clip (Right Door only)	30001716
72. Front Door Handle & Shaft	30002717
73. Right Door	See Chart Pg. 38
74. Door Gasket	1203588
75. Gasket, Fiberglas 3/16 4nd, Blk	1203556
76. Left Door Glass ²	1600064
77. Right Door Glass ²	1600062
78. Lower Door Hinge Pin	30002727
79. Spacer (for Damper Rod)	1201779
80. Upper Door Hinge Pin	30002727
81. Handle Base Stub	30002714
82. Wood Handle	1600664
83. Handle Bolt	1201310
84. Thermostat Handle Bolt	1201243
85. Ash Pan Assy ⁵	30001690
86. Flat Washer	1202475
87. Flue Collar	See Chart Pg. 38
88. Leg	See Chart Pg. 38
89. Finish Bag	30001695
90. Washer, 1/4 Flat	1202471
91. Hex Head Jam Nut	1203290
92. Bottom Heat Shield (not shown)	1400008
93. Ashdoor Heat Shield (not shown)	1401911
94. HS Spacer 1.25" (not shown)	1601755
95. Control Spacer (not shown)	1201781

NOTES:

In this diagram and throughout this manual, 'left' and 'right' mean as you face the stove.

When ordering parts, be sure to mention the stove's model number. When ordering external parts, be sure to specify color.

1. Included in Item #19, #5000030 Upper Fireback Assy.

2. Not interchangeable, due to a heat-reflective coating on the room side of the glass.

3. Included in Item #59, 5000024 Primary Air Assy.

The hardware in the Defiant is in standard sizes; most bolts are 1/4" diameter by 20 threads per inch. Any hardware store can supply replacement hardware if you specify bolt diameter, number of threads per inch and length.

Defiant Woodburning Stove Model 1945 (continued)

Shell Enamel Parts - Defiant						
Enamel Color	Top	Left Side	Right Side	Front	Ashlip	Leg
Classic	30001582	30001580	30001579	30001578	1300621	30001583
Biscuit	30002967	30002963	30002962	30002964	30002961	30002968
Bordeaux	30002957	30002953	30002952	30002954	30002951	30002958
Chestnut Brown	30002977	30002973	30002972	30002974	30002971	30002978
Ebony	30002987	30002983	30002982	30002984	30002981	30002988
Forest Green	30001627	30001626	30001625	30001624	2310621	30001628
Midnight Blue	30001621	30001620	30001619	30001618	2370621	30001622
Sand	30001615	30001614	30001613	30001612	1320621	30001616
Suede Brown	30002578	30002574	30002573	30002575	30002583	30002580
Vermont Classic Green	30002997	30002993	30002992	30002994	30002991	30002998

Shell Enamel Parts - Defiant					
Enamel Color	Flue Collar	Left Door Subassembly	Left Door Only	Right Door Subassembly	Right Door Only
Classic	30001576	30001719*	1300626	30001718*	1300625
Biscuit	30002947	30002970	30002966	30002969	30002965
Bordeaux	30002921	30002960	30002956	30002959	30002955
Chestnut Brown	30002932	30002980	30002976	30002979	30002975
Ebony	30002910	30002990	30002986	30002989	30002985
Forest Green	30001623	30001725	2310626	30001724	2310625
Midnight Blue	30001617	30001723	2370626	30001722	2370625
Sand	30001611	30001721	1320626	30001720	1320625
Suede Brown	30002579	30002582	30002577	30002581	30002576
Vermont Classic Green	30002943	30003000	30002996	30002999	30002995

*NOTE: Does not contain glass or glass gasket.

Warranty

Limited 3 Year Warranty

MHSC warrants that this woodburning stove will be free of defects in material and workmanship for a period of three years from the date you receive it, except that the catalyst, thermostat assembly, handles, glass door panels, cement, and gasketing shall be warranted as described below.

MHSC will repair or replace, at its option, any part found to be defective upon inspection by a Vermont Castings, Authorized Dealer. The customer must return the defective part or the stove, with shipping prepaid, to the Authorized Dealer or pay for any Authorized Dealer in-home travel fees or service charges for in-home repair work. It is the dealer's option whether the repair work will be done in the customer's home or in the dealer's shop. If, upon inspection, the damage is found to be the fault of the manufacturer, repairs will be authorized at no charge to the customer for parts and/or labor.

Any woodburning stove or part thereof that is repaired or replaced during the limited warranty period will be warranted under the terms of the limited warranty for a period not to exceed the remaining term of the original limited warranty or six (6) months, whichever is longer.

Limited 1 Year Warranty

The following parts of the woodburning stove are warranted to be free of defects in material and workmanship for a period of one year from the date you receive it: The thermostat assembly, handles, glass door panels, cement, and gasketing. Any of these items found to be defective will be repaired or replaced at no charge, upon the return of the part with postage prepaid to a Vermont Castings Authorized Dealer.

Any part repaired or replaced during the limited warranty period will be warranted under the terms of the limited warranty for a period not to exceed the remaining term of the original limited warranty or six (6) months, whichever is longer.

Limited Catalyst Warranty

The catalyst will be warranted for a six year period as follows: If the original catalyst or a replacement catalyst proves defective or ceases to maintain 70% of its particulate emission reduction activity (as measured by an approved testing procedure) within 24 months from the date the stove is received, the catalyst itself will be replaced free.

From 25 - 72 months a pro-rated credit will be allowed against a replacement catalyst and the cost of labor necessary for its installation at the time of replacement.

For stove purchases made after June 30, 1990, a third year (25 - 36 months) of no charge replacement will be made when combustor failure is due to thermal degradation of the substrate (crumbling of ceramic material). The customer must pay for any in-home travel fees, service charges, or transportation costs for returning the stove to the Authorized Dealer.

Amount of Time Since Purchase	Credit Towards Replacement Cost
0 - 36 months	100%
37 - 48 months	30%
49 - 60 months	20%
61 - 72 months	10%

Any replacement catalyst will be warranted under the terms of the catalyst warranty for the remaining term of the original warranty. The purchaser must provide the following information in order to receive a replacement catalyst under the terms of this limited warranty:

1. Name, address and telephone number.
2. Proof of original purchase date.
3. Date of failure of catalyst.
4. Any relevant information or circumstances regarding determination of failure.
5. In addition, the owner must return the failed catalyst.

Exclusions & Limitations

1. This product must be installed or serviced by a qualified installer, preferably NFI or WETT (Canada) certified, as prescribed by the local jurisdiction. It must be installed and operated at all times in accordance with the Installation and Operating instructions furnished with the product any alteration, willful abuse, accident or misuse of this product shall nullify this warranty.
2. This warranty is transferable; however, proof of original retail purchase is required.
3. This warranty does not cover misuse of the stove. Misuse includes overfiring which will result if the stove is used in such a manner as to cause one or more of the plates to glow red. Overfiring can be identified later by warped plates and areas where the paint pigment has burned off. Overfiring in enamel fireplaces is identified by bubbling, cracking, chipping and discoloration of the porcelain enamel finish. MHSC offers no warranty on chipping of enamel surfaces. Inspect your woodburning stove prior to accepting it for any damage to the enamel.
4. This warranty does not cover misuse of the stove as described in the Owner's Guide, nor does it cover a stove which has been modified unless authorized by a MHSC representative in writing. This warranty does not cover damage to the stove caused by burning salt saturated wood, chemically treated wood, or any fuel not recommended in the Owner's Guide.
5. This warranty does not cover a stove repaired by someone other than a Vermont Castings Authorized Dealer.
6. Damage to the unit while in transit is not covered by this warranty but is subject to a claim against the common carrier. Contact Vermont Castings Authorized Dealer from whom you purchased your stove or MHSC if the purchase was direct. (Do not operate the stove as this may negate the ability to process the claim with the carrier.)
7. Claims are not valid where the installation does not conform to local building and fire codes or, in their absence, to the recommendations in our Owner's Guide.
8. The salt air environment of coastal areas, or a high-humidity environment, can be corrosive to the porcelain enamel finish. These conditions can cause rusting of the cast iron beneath the porcelain enamel finish, which will cause the porcelain enamel finish to flake off. This warranty does not cover damage caused by a salt air or high-humidity environment.
9. MHSC shall have no obligation to enhance or update any unit once manufactured.

IN NO EVENT SHALL MHSC BE LIABLE FOR INCIDENTAL AND CONSEQUENTIAL DAMAGES. ALL IMPLIED WARRANTIES, INCLUDING THE IMPLIED WARRANTIES OF MERCHANTABILITY AND FITNESS, ARE LIMITED TO THE DURATION OF THIS WRITTEN WARRANTY. THIS WARRANTY SUPERCEDES ALL OTHER ORAL OR WRITTEN WARRANTIES.

Some states do not allow the exclusion or limitations of incidental and consequential damages or limitations on how long an implied warranty lasts, so the above limitations may not apply to you. This warranty gives you specific rights and you may have other rights which vary from state to state.

How to Obtain Service

If a defect is noted within the warranty period, the customer should contact a Vermont Castings Authorized Dealer or MHSC if the purchase was direct with the following information:

1. Name, address, and telephone number of the purchaser.
2. Date of purchase.
3. Serial number from the label on the back.
4. Nature of the defect or damage.
5. Any relevant information or circumstances, e.g., installation, mode of operation when defect was noted.

A warranty claim will then start in process. MHSC reserves the right to withhold final approval of a warranty claim pending a visual inspection of the defect by authorized representatives.

Mountain View Hearth Products
manuals.stove-parts-unlimited.com

MHSC

149 Cleveland Drive • Paris, Kentucky 40361
www.mhsc.com