

Owner's Manual

Installation and Appliance Setup - Care and Operation

INSTALLER: Leave this manual with party responsible for use and operation.

OWNER: Retain this manual for future reference.

Call your dealer for questions on Installation, Operation, or Service.



NOTICE: SAVE THESE INSTRUCTIONS

VERMONT  CASTINGS

Defiant® FlexBurn® Non-Catalytic/
Catalytic Wood Burning Stove
Model 1975

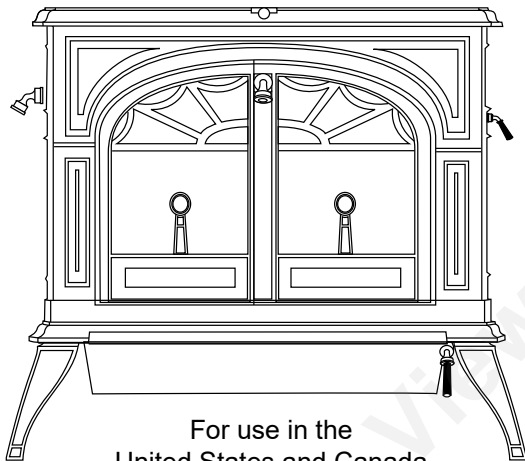

For use in the
United States and Canada

SAFETY NOTICE: IF THIS APPLIANCE IS NOT PROPERLY INSTALLED, OPERATED AND MAINTAINED, A HOUSE FIRE MAY RESULT.

TO REDUCE THE RISK OF FIRE, FOLLOW THE INSTALLATION INSTRUCTIONS. FAILURE TO FOLLOW INSTRUCTIONS MAY RESULT IN PROPERTY DAMAGE, BODILY INJURY OR EVEN DEATH. CONTACT LOCAL BUILDING OFFICIALS ABOUT RESTRICTIONS AND INSTALLATION INSPECTION REQUIREMENTS IN YOUR AREA.

WARNING



Please read this entire manual before installation and use of this wood-burning room heater.

Failure to follow these instructions could result in property damage, bodily injury or even death.

- Do not store or use gasoline or other flammable vapors and liquids in the vicinity of this or any other appliance.
- Do not overfire - If any external part starts to glow, you are overfiring. Close air controls. Overfiring will void your warranty.
- Comply with all minimum clearances to combustibles as specified. Failure to comply may cause a house fire.

CAUTION

Tested and approved for use with dry, seasoned cordwood only. Do Not Burn Wet or Green Wood. Burning any other type of fuel will void your warranty.

Installation and service of this appliance should be performed by qualified personnel. Hearth & Home Technologies recommends HHT Factory Trained or NFI certified professionals.



We recommend that our woodburning hearth products be installed and serviced by professionals who are certified in the U.S. by the National Fireplace Institute® (NFI) as NFI Woodburning Specialists or who are certified in Canada by Wood Energy Technical Training (WETT).



The French language version of this manual is available online: www.vermontcastings.com
La version française de ce manuel est disponible en ligne: www.vermontcastings.com

Congratulations on your choice of a Vermont Castings Defiant® stove. With this purchase you have made a commitment to make the hearth a place of warmth, beauty and comfort in your home. At Vermont Castings, we share that joy and appreciation for the hearth. We assure you that your cast-iron Vermont Castings stove has been made with the utmost care and will provide you with many years of service.

As you become acquainted with your new stove, you will find that its appearance is matched by its functionality, due to cast iron's unique ability to absorb and radiate heat.

Also, Vermont Castings products are among the cleanest-burning wood stoves and fireplaces available today. As an owner of a Vermont Castings stove, you make a strong statement for pollution-free energy. However, clean burning depends on both the manufacturer and the operator. Please read this manual carefully to understand how to properly operate and maintain your stove.

At Vermont Castings, we are equally committed to your satisfaction as a customer. That is why we maintain an exclusive network of the finest dealers in the industry. Our dealers are chosen for their expertise and dedication to customer service. They are factory-trained and knowledgeable about every Vermont Castings product. Feel free to contact your Authorized Vermont Castings Dealer anytime you have a particular question about your stove or its performance.

This manual contains valuable instructions on the installation and operation of your Vermont Castings Defiant®. It also contains useful information on maintenance. Please read the manual thoroughly and keep it as a reference.

This manual describes the installation, operation, and maintenance of the Vermont Castings Defiant® Model 1975 Non-Catalytic / Catalytic wood burning heater. This heater meets the U.S. Environmental Protection Agency's emission limits for wood heaters sold on or after May 15, 2015.

The Defiant® Model #1975 has been tested and is listed by OMNI-Test Laboratories of Portland, Oregon. The test standards are ANSI/UL-1482-2011 and ANSI/UL-737 for the United States, and ULC S627-00 for Canada. The Defiant® is listed for burning wood only. Do not burn other fuels. The Defiant® is not approved for use in manufactured (mobile) homes.

Please read this entire manual before you install and use your new stove. Failure to follow instructions may result in property damage, bodily injury, or even death.

Installation Accessories			
Warming Shelf			
#0210	Classic Black	#0217	Brown Majolica
#0211	Biscuit	#0219	Twilight
#0218	Bordeaux		
#3264	Mobile Home Bracket Kit		
#3180	Outside Air Adapter		
#1907	Firescreen		
#1860	6" X 12" Oval Starter Pipe		
#1855	8" X 11" Oval Starter Pipe		
#3190	Pipe Heatshield		
FK26	Fan Kit		
#0180	Rectangular Ceiling Kit		
#0181	Round Ceiling Kit		
A line of porcelain enamel stove pipe is available in Biscuit, Bordeaux, Brown Majolica colors.			

Table of Contents

Product Specifications and Important Safety Information	
Appliance Certification	3
California safety information	3
BTU & Efficiency Specifications	3
Dimensions	4
Installation	
Outside Air	5
Types of Chimney to Use	6
Chimney Size	6
Chimney Connector Guidelines	7
Fireplace Installations	8
Floor Protection	11
Clearances to Combustibles	12
Assembly	
Setting up your Stove	18
Install Bottom Heat Shield	18
Adjust Leg Levelers	19
Installing Catalyst Temperature Probe	19
Attaching Damper Handle	19
Fan Kit Installation	20
Installing / Removing Catalyst	20
Smoke Alarm / Safety Tips	21
Operation	
Air Controls	22
Damper Adjustments	22
Wood Burning Operation	23
Ash Disposal	27
Draft Management	28
Maintenance	30
The Catalytic Element	33
Service Parts List	35
Warranty	41

➔ = Contains updated information

Product Specifications and Important Safety Information

Appliance Certification

MODEL:	Defiant®, Model 1975
LABORATORY:	OMNI Test Laboratories, Inc
REPORT NO.	227-S-40-2
TYPE:	Solid Fuel Room Heater / Wood Burning Type
STANDARD(s):	UL 1482-2011, UL 737-2011, ULC-S627-00
ELECTRICAL RATING:	115 VAC, 60 Hz

Area Heated..... 1,300 to 2,800 Square feet
Loading..... Front and top
Chimney Connector:
 for 6" flue collar6" (152 mm) diameter
 for 8" oval flue collar.....8" (203 mm) diameter
Flue Exit Position Top or Rear
Primary Air Manually set, thermostatically maintained
Secondary Air Fixed, self-regulating
Ash Handling System..... Removable ash pan
Glass Panels High-temperature ceramic
Weight.....475 lbs. (215 kg.)

California safety information



WARNING

This product and the fuels used to operate this product (wood), and the products of combustion of such fuels, can expose you to chemicals including carbon black, which is known to the State of California to cause cancer, and carbon monoxide, which is known to the State of California to cause birth defects or other reproductive harm. For more information go to: www.P65Warnings.ca.gov

Proposition 65 Warning: Fuels used in gas, woodburning or oil fired appliances, and the products of combustion of such fuels, contain chemicals known to the State of California to cause cancer, birth defects and other reproductive harm.

California Health & Safety Code Sec. 25249.6

BTU & Efficiency Specifications

EPA Certification Number:	783
Non-Catalytic Information	
EPA Certified Emissions:	2.3 g/hr
*EPA Default Efficiency:	71.0%
**Actual tested Efficiency:	66%
***EPA BTU Output:	9,600 - 26,600
****Peak BTU/Hour Output:	55,900
Catalytic Information	
EPA Certified Emissions:	1.1 g/hr
*EPA Default Efficiency:	80.0%
**Actual tested Efficiency:	73.8%
***EPA BTU Output:	11,400 - 34,100
****Peak BTU/Hour Output:	55,500
Other Important Information	
Vent Size:	6 Inch (152 mm) 8 Inch (203 mm)
Firebox Size:	3.2 cu. ft.
Max. Wood Length:	25" Maximum
Ideal Wood Length:	20" (Top Load)
Fuel	Seasoned Cordwood (20% moisture)

*An efficiency based on EPA historical data: 63% for non-catalytic stoves.

**Maximum calculated efficiency using Douglas Fir dimensional lumber and data collected during EPA emissions test.

***A range of BTU outputs based on EPA Default Efficiency and the burn rates from the low and high EPA tests, using Douglas Fir dimensional lumber.

**** A peak BTU out of the unit calculated using the maximum first hour burn rate from the High EPA Test and BTU content of seasoned cordwood (8600) times the efficiency.

This wood heater needs periodic inspection and repair for proper operation. It is against federal regulations to operate this wood heater in a manner inconsistent with operating instructions in this manual.

Dimensions

Drawing Not to Scale

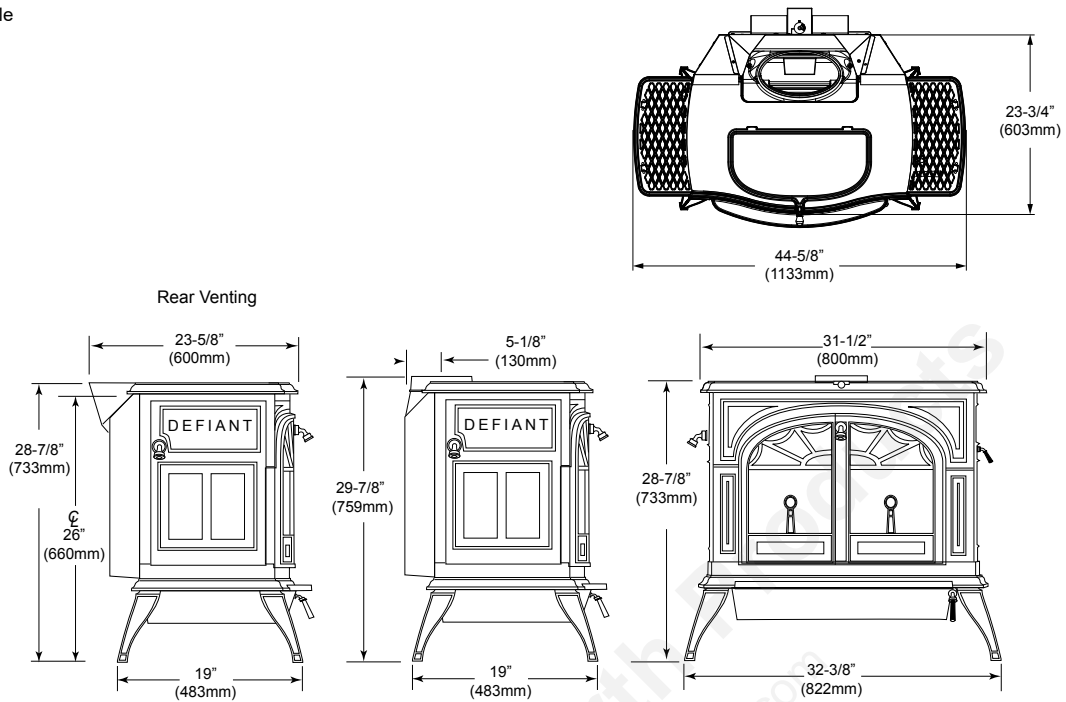

Figure 1 - Defiant® 1975 dimensions.

Installation

SAFETY NOTICE: IF YOUR DEFIANT® IS NOT PROPERLY INSTALLED, A HOUSE FIRE MAY RESULT. TO REDUCE THE RISK OF FIRE, FOLLOW THE INSTALLATION INSTRUCTIONS. CONTACT LOCAL BUILDING OR FIRE OFFICIALS ABOUT RESTRICTIONS AND INSTALLATION INSPECTION REQUIREMENTS IN YOUR AREA.

Before you begin an installation, be sure that:

- Your stove and chimney connector will be far enough from combustible material to meet all clearance requirements.
- The floor protector is large enough and is constructed properly to meet all requirements.
- You have all necessary permits from local authorities.

Your local building official is the final authority for approving your installation as safe and determining that it meets local and state codes.

The metal label permanently attached to the back of every Vermont Castings' stove indicates that the stove has been tested to current UL and ULC standards, and gives the name of the testing laboratory. Clearance and installation information also is printed on the label. When the stove is installed according to the information both on the label and in this manual, local authorities usually will accept the label as evidence that the installation meets codes and can be approved.

However, codes vary in different areas. Before starting the installation, review your plans with the local building authority. Your local dealer can provide any additional information needed.

For any unresolved installation issues, refer to the National Fire Protection Association's publication ANSI/NFPA 211 Standard for Chimneys, Fireplaces, Vents and Solid Fuel Burning Appliances. For Canada, the equivalent publication is CSA CAN-B365 Installation Code for Solid Fuel Burning Appliances and Equipment. These standards are the basis for many national codes. They are nationally recognized and are accepted by most local authorities. Your local dealer or your local building official may have a copy of these regulations.

IMPORTANT: Failure to follow these installation instructions may result in a dangerous situation, including a chimney or house fire. Follow all instructions exactly, and do not allow makeshift compromises to endanger property and personal safety.

Outside Air

A source of air (oxygen) is necessary in order for combustion to take place. Whatever combustion air is consumed by the fire must be replaced. Air is replaced via air leakage around windows and under doors. In homes that have tightly sealed doors and windows, an outside air source is needed.

Items Needed for Installation (not supplied)

- Outside air adapter (available at your authorized Vermont Castings dealer)
 - Phillips head screw driver
 - Silicone sealant
 - 3" Flex or Rigid Duct
 - 3" Outside Air Termination Cap with Screen
 - Hose Clamps
 - Drills and saws necessary for cutting holes through the wall or flooring in your home.
1. Using a #2 Phillips screw driver attach the flex adapter to the appliance using 4 screws. Figure 5.13 & 5.14.
 2. Floor & Rear Installation: Cut a 3" (76 mm) hole in outside wall or floor to accommodate outside air piping. Use 3" (76 mm) aluminum metal flex or rigid piping to directly connect outside air to appliance intake. Use the supplied termination cap with a rodent screen. Seal between the wall (or floor) and the pipe with silicone to prevent moisture penetration.

When poor draft is caused by a low infiltration rate, opening a ground floor window on the windward side of the house and near the stove will usually alleviate the problem.

A better solution is to install a permanent outside air supply to the stove and/or room. In fact, bringing air for combustion from outside the home directly to the air inlet of the stove is required for new construction in some areas.

Chimney Height

Altitude affects chimney performance. When using an 8" oval to 6" flue collar adapter on the Defiant®, refer to Figure 1 for suggested chimney heights at various altitudes. Chimney height should be measured from the flue collar to the top of the chimney. The recommended minimum chimney height is 16' (5 m).

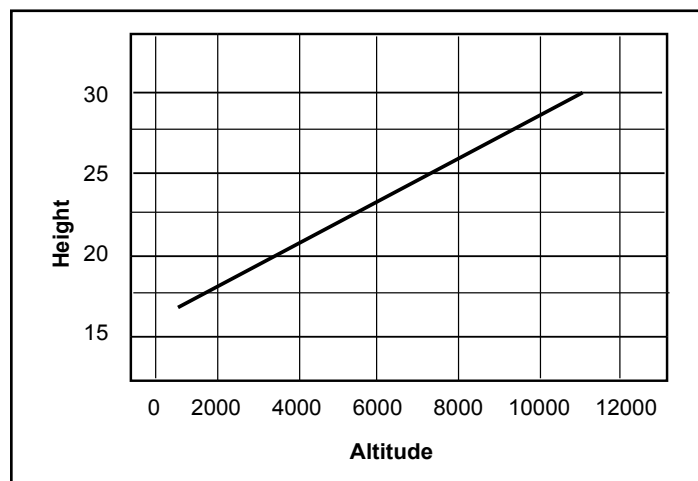

Figure 2 - Chimney height requirements with 6" chimney and/or chimney connector.

Types of Chimney to Use

You must connect the Defiant® to a code-approved masonry chimney with a flue liner, to a relined masonry chimney that meets local codes, or to a prefabricated metal chimney that complies with the requirements for Type HT chimneys in the Standard for Chimneys, Factory-Built, Residential Type and Building Heating Appliance, UL 103. Figure 3 illustrates the two types. The chimney and chimney connector must be in good condition and kept clean.

If you use an existing masonry chimney, it must be inspected to ensure it is in a safe condition before the stove is installed. Your local professional chimney sweep, building inspector, or fire department official will be able to inspect the chimney or provide a referral to someone who can. See "Chimney and Fireplace hazards", in the appendix, for particulars.

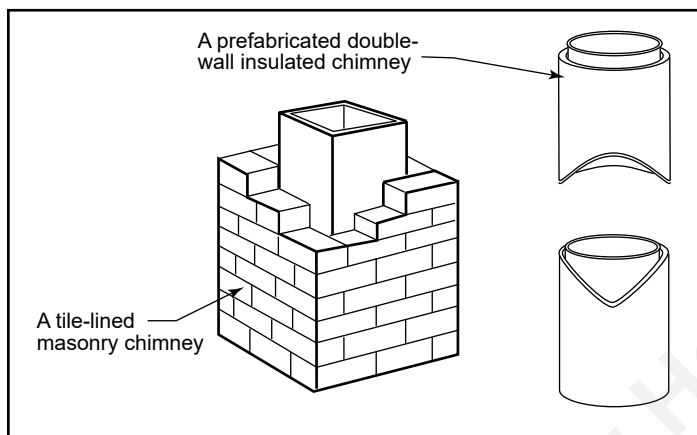

Figure 3 - Approved chimney types.

The chimney must extend at least 3' (914 mm) above the highest point where it passes through or near a roof, and at least 2' (610 mm) higher than any part of a building within 10' (3 m) horizontally. (Figure 4)

For proper draft and good performance, any chimney used with a Defiant® should extend at least 16' (5 m) above the flue collar of the stove.

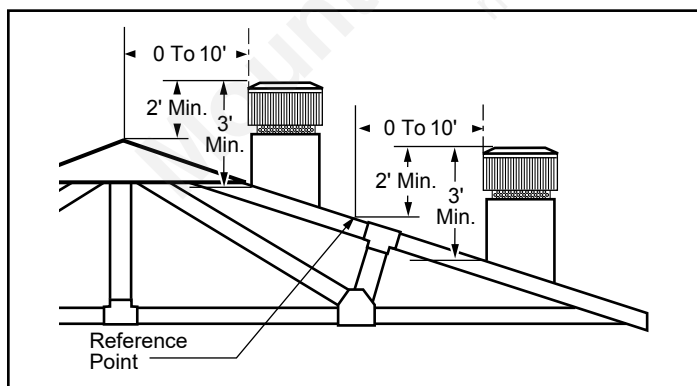

Figure 4 - The 2'-3'-10' Chimney Rule.

Masonry Chimneys

An inspection of the chimney must confirm that it has a lining. Do not use an unlined chimney. The chimney should have no cracks, loose mortar, other signs of deterioration, and blockage. Repair any defects before the chimney is used with your stove.

Unused openings in an existing masonry chimney must be sealed with masonry to the thickness of the chimney wall, and the chimney liner should be repaired. Openings sealed with pie plates or wallpaper are a hazard and should be sealed with mortar or refractory cement. In the event of a chimney fire, flames and smoke may be forced out of these unused thimbles.

The chimney should be thoroughly cleaned before use.

A newly-built masonry chimney must conform to the standards of your local building code or, in the absence of a local code, to a recognized national code. Masonry chimneys must be lined, either with code-approved masonry or pre-cast refractory tiles, stainless steel pipe, or a code-approved, "poured-in-place" liner. The chimney's clean-out door must seal tightly. A loose or leaky clean-out door can weaken chimney draft, causing performance problems.

Prefabricated Chimneys

A prefabricated metal chimney must be one tested and listed for use with solid-fuel burning appliances to the High-Temperature (H.T.) Chimney Standard UL-103-1985 (2100°F) for the United States, and High Temperature (650°C) Standard ULC S-629 for Canada.

DO NOT CONNECT THIS UNIT TO A CHIMNEY FLUE SERVING ANOTHER APPLIANCE.

Chimney Size

A Defiant® with an 8" (203 mm) flue collar is approved for venting into a masonry chimney with a nominal flue size of 8" x 8" (203 x 203 mm) or 8" x 12" (203 x 305 mm), and into a round flue with nominal flue size of 8" (203 mm). A Defiant® with a 6" (152 mm) flue connector is approved for venting into a masonry chimney with a nominal flue size of 8" x 8" (203 x 203 mm), and into a round flue with nominal flue of 6" (152 mm).

NOTE: When installed with a 6" flue collar, the Defiant® may not be operated with the front doors open.

Whatever the flue collar size, a Defiant® may be vented into larger chimneys as well. However, chimneys with liners larger than 8" x 12" (203 x 305 mm) may experience rapid cooling of smoke and reduction in draft, especially if the chimneys are located outside the home. These large chimneys may need to be insulated or have their flues relined for proper stove performance.

Accessories to help make the connection between stainless steel chimney liners and your Defiant® are available through your local dealer.

Chimney Connector Guidelines

A chimney connector is the single-wall pipe that connects the stove to the chimney. The chimney itself is the masonry or prefabricated structure that encloses the flue. Chimney connectors are used only to connect the stove to the chimney.

Single-wall connectors should be made of 24 gauge or heavier steel. Do not use galvanized connector; it cannot withstand the high temperatures that can be reached by smoke and exhaust gases, and may release toxic fumes under high heat. The connector may be 6" (152 mm) or 8" (203 mm) in diameter.

If possible, do not pass the chimney connector through a combustible wall or ceiling. If passage through a combustible wall is unavoidable, refer to the section on Wall Pass-Throughs. Do not pass the connector through an attic, a closet or similar concealed space. The whole connector should be exposed and accessible for inspection and cleaning.

In horizontal runs of unshielded chimney connector, maintain a distance of 30" (762 mm) from the ceiling. Keep it as short and direct as possible, with no more than two 90° turns. Slope horizontal runs of connector upward 1/4" per foot (6mm per meter) going from the stove toward the chimney. The recommended maximum length of a horizontal run is 3' (1 m), and the total length should be no longer than 8' (2.4 m). In cathedral ceiling installations, extend the prefabricated chimney downward to within 8' (2.4 m) of the stove. This will help maintain a good draft by keeping the smoke warm, so that it rises readily.

Wear gloves and protective eyewear when drilling, cutting or joining sections of chimney connector.

Single-wall Chimney Connectors

- Begin assembly at the oval flue collar of the stove. Insert the crimped end of the oval-to-round adapter into the stove's flue collar, and keep each crimped end pointing toward the stove. (Figure 5) Using the holes in the flue collar as guides, drill 1/8" (3 mm) holes in the bottom of the first section of chimney connector and secure it to the flue collar with three #10 x 1/2" sheet metal screws. Lift off the griddle, and shield the stove's surface between the griddle opening and the front of the flue collar to protect the finish when you drill the front hole.

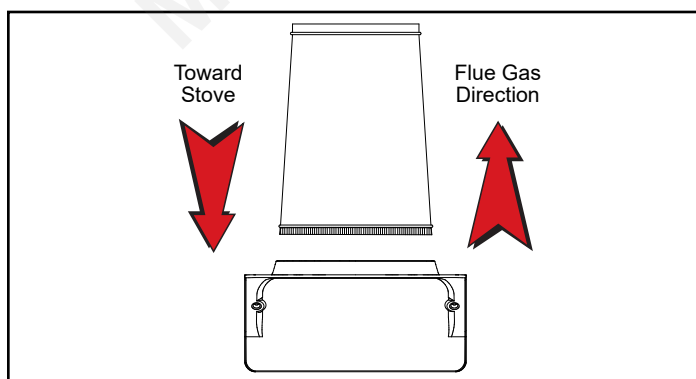

Figure 5 - Chimney connector.

- Fasten each joint between sections of chimney connector, including telescoping joints, with at least three (3) sheet metal screws. The pre-drilled holes in the top of each section of chimney connector serve as guides when you drill 1/8" (3 mm) holes in the bottom of the next section. Furnace cement may be used to seal the oval-to-round adapter to the flue collar.
- Fasten the chimney connector to the chimney. Instructions for various installations follow. Figure 6 illustrates the general layout of chimney connector parts.
- Be sure the installed stove and chimney connector are correct distances from nearby combustible materials.

NOTE: Special slip pipes and thimble sleeves that form telescoping joints between sections of chimney connector are available to simplify installations. They often eliminate the need to cut individual connector sections. Consult your local dealer about these special pieces.

Securing the Single-wall Connector to a Prefabricated Chimney

Follow the installation instructions of the chimney manufacturer exactly as you install the chimney. The manufacturer of the chimney will supply the accessories to support the chimney, either from the roof of the house, at the ceiling of the room where the stove is installed, or from an exterior wall.

Special adapters are available from your local dealer to make the connection between the prefabricated chimney and the chimney connector. The top of such adapters attaches directly to the chimney or to the chimney's ceiling support package, while the bottom of the adapter is screwed to the chimney connector.

These adapters are designed so the top end will fit outside the inner wall of the chimney, and the bottom end will fit inside the first section of chimney connector.

Securing the Single-wall Connector to a Masonry Chimney

Both freestanding masonry chimneys and fireplace masonry chimneys may be used for your installation.

Freestanding Installations

If the chimney connector must pass through a combustible wall to reach the chimney, follow the recommendations in the Wall Pass-Through section that follows. The opening through the chimney wall to the flue (the "breech") must be lined with either a ceramic or metal cylinder, called the "thimble," which is cemented securely in place. Most chimney breeches incorporate thimbles, but the fit must be snug and the joint between the thimble and the chimney wall must be cemented firmly.

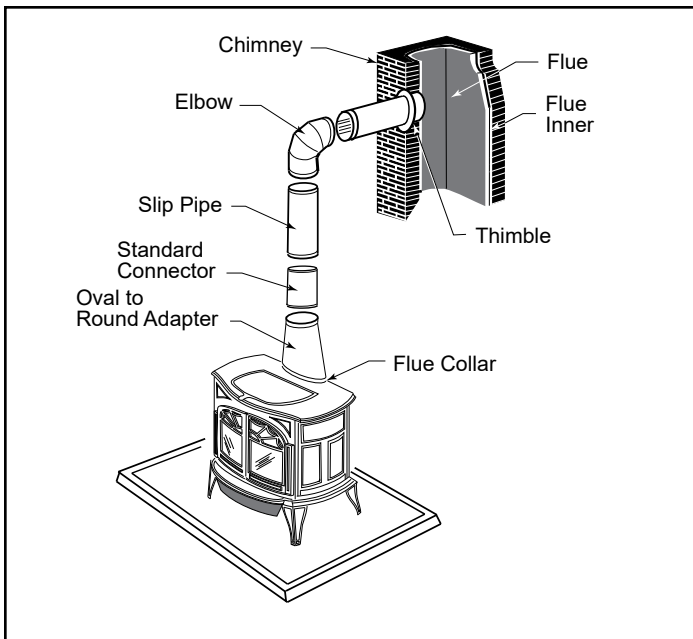

Figure 6 - An exploded view of the chimney connection in a freestanding masonry installation.

A special piece called the "thimble sleeve," slightly smaller in diameter than standard connectors and most thimbles, will facilitate the removal of the chimney connector system for inspection and cleaning. (Figure 7) Thimble sleeves are available from your local dealer.

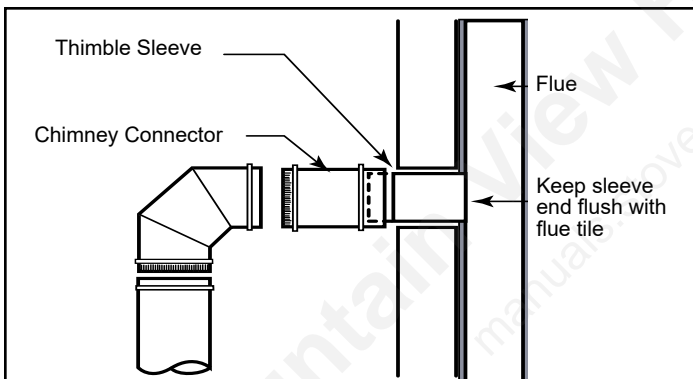

Figure 7 - The thimble, made of either ceramic or metal, must be cemented securely in place.

To install a thimble sleeve, slide it into the breach until it is flush with the inner flue wall. Do not extend it into the actual flue passage, as this could interfere with the draft.

The thimble sleeve should protrude 1-2" (25-50 mm) into the room. Use furnace cement and thin gasketing to seal the sleeve in place in the thimble. Secure the chimney connector to the outer end of the sleeve with sheet metal screws.

Without a thimble, a suitable length of chimney connector can be extended through the breach to the inner face of the flue liner, and cemented securely in place. Additional pieces of connector are then attached with sheet metal screws.

Fireplace Installations

The chimney connector may be connected to the chimney above the fireplace opening or through the fireplace.

Above the Fireplace

The Defiant® may be connected to a chimney above a fireplace opening. (Figure 8) In such installations, the stove is positioned on the hearth in front of the fireplace and the chimney connector rises from the stove top and then angles ninety degrees back into the chimney. The chimney liner should extend to the point at which the chimney connector enters the chimney.

If the chimney connector in your installation enters the chimney above a fireplace, follow all the guidelines mentioned above for freestanding installations. In addition, give special consideration to the following points:

- Check the clearance between the stove and the chimney connector, and any combustible trim or the mantel.
- Check the clearance between the chimney connector and the ceiling. The clearance should be at least 30" (762 mm) with unshielded connectors. Consult the clearance charts for other installation options.
- The fireplace damper must be sealed to prevent room air from escaping up the flue. However, it must be possible to re-open the damper to inspect or clean the chimney.

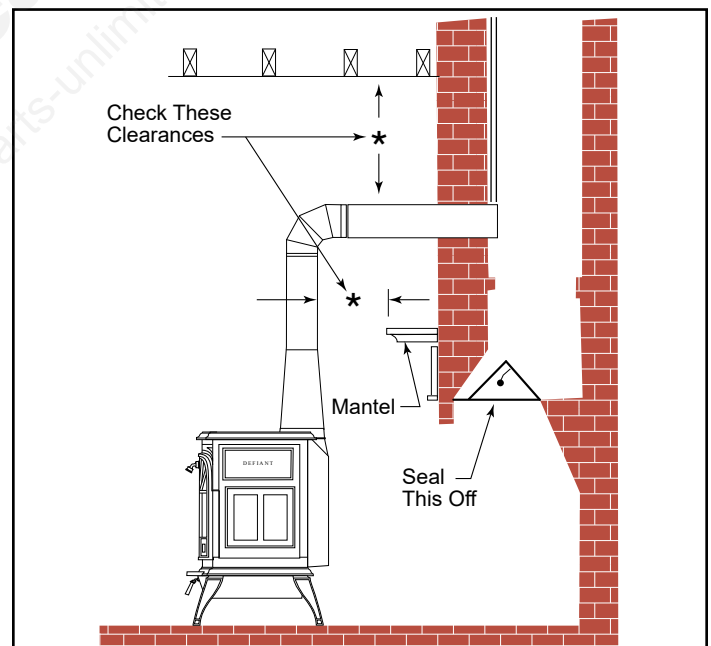

Figure 8 - In this installation, the chimney connector attaches to the chimney above the fireplace opening.

Through the Fireplace

If your fireplace opening height is at least 29" (737 mm), you may install a Defiant® through the opening using a "positive connection" kit, available from your local dealer. Positive connection kits ensure a tight fit between the stove flue collar and the chimney flue. (Figure 9)

Fireplace installations, whether connected to the flue above or through the fireplace opening, have special clearance requirements to adjacent trim and the mantel. You'll find the required safe clearances for Defiant® fireplace installations on Page 13.

Floor protection requirements also apply to fireplace installations. This information is on Page 11.

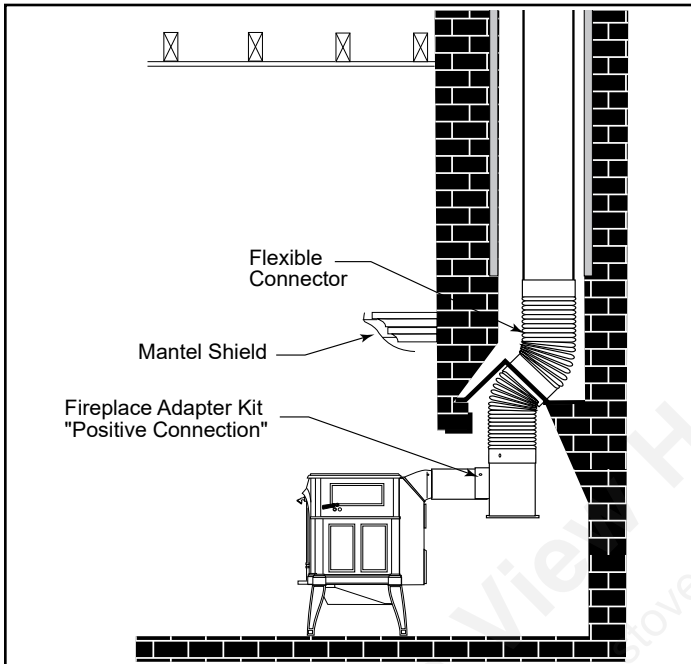

Figure 9 - Through the fireplace installation.

Wall Pass-Throughs

Whenever possible, design your installation so the connector does not pass through a combustible wall. If you are considering a wall pass-through in your installation, check with your building inspector before you begin. Also, check with the chimney connector manufacturer for any specific requirements.

Accessories are available for use as wall pass-throughs. If using one of these, make sure it has been tested and listed for use as a wall pass-through.

In the United States, the National Fire Protection Association (NFPA) has established guidelines for passing chimney connectors through combustible walls. Many building code inspectors follow these guidelines when approving installations.

Figure 10 shows one NFPA recommended method. All combustible material in the wall is cut away from the single-wall connector to provide the required 12" (305 mm) clearance. Any material used to close up the opening must be noncombustible.

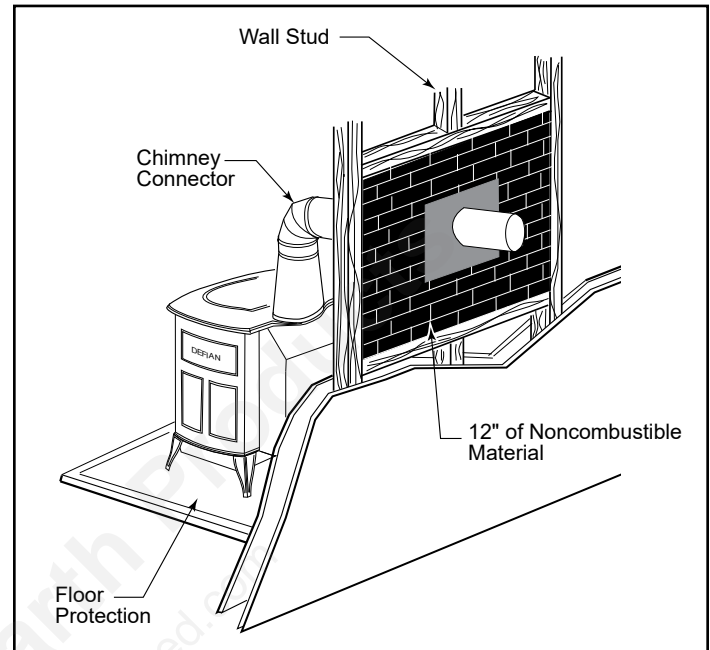

Figure 10 - An approved wall pass-through for the United States.

Three other methods are also approved by the NFPA:

- Placing a section of chimney connector inside a ventilated thimble, which in turn is separated from combustibles by 6" (152 mm) of fiberglass insulating material.
- Placing a section of chimney connector inside a section of 9" (230 mm) diameter, solid-insulated, factory-built chimney, with 2" (51 mm) of air space between the chimney section and combustibles.
- Using a section of solid-insulated double-wall high temperature chimney, with an inside diameter the same as the chimney connector, at least one inch of solid insulation, and a minimum of 9" (229 mm) air space between the outer wall of the chimney section and combustibles.

In Canada, The Canadian Standards Association has established different guidelines for wall pass-throughs. Figure 11 shows one method, in which all combustible material in the wall is cut away to provide the required 18" (457 mm) clearance for the connector. The resulting space must remain empty. A flush-mounted sheet metal cover may be used on one side only. If covers must be used on both sides, each cover must be mounted on noncombustible spacers at least 1" (25 mm) clear of the wall.

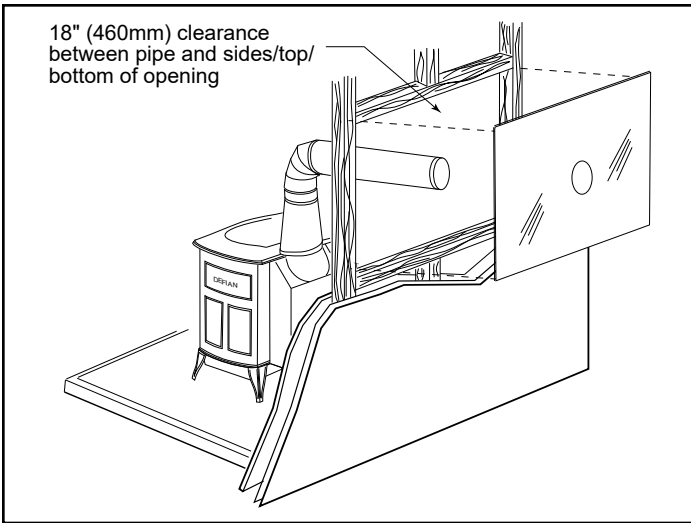

Figure 11 - An approved wall pass-through for Canada.

Your local dealer or your local building inspector can provide details for other approved methods of passing a chimney connector through a combustible wall in your area. In Canada, this type of installation must conform to CAN/CSA-B365, Installation Code for Solid Fuel Burning Appliances and Equipment.

NOTE: Do not vent your Defiant® into a factory-built (zero-clearance) fireplace. These appliances and their chimneys are specifically designed as a unit for use as fireplaces. It may void the listing or be hazardous to adapt them for any other use.

DO NOT CONNECT THE DEFIANT® TO ANY AIR DISTRIBUTION DUCT OR SYSTEM.

Floor Protection

A tremendous amount of heat radiates from the bottom plate of your stove. The floor area directly under and around the stove will require protection from radiant heat as well as from stray sparks or embers that may escape the firebox.

Heat protection is provided with the use of the Bottom Heat Shield supplied with the stove.

Most installations will require the bottom heat shield to be attached. Only when the stove is placed on a completely noncombustible surface such as unpainted concrete over earth may it be used without the heat shield.

With the bottom heat shield installed the Defiant® 1975 was tested using a 1/2" (13mm) non-combustible hearth material with a thermal conductivity, (k) = 0.47 BTU - in/hr - ft² - °F, resulting in the requirement of providing a total thermal resistance (R) of 1.06. (Refer to "How to Determine if Alternate Floor Protection Materials are Acceptable" section.) The floor protector may be covered with a decorative noncombustible material if desired. Do not obstruct the space under the heater.

When using a fire screen with doors open, UL737, Standard for Fireplace Stoves, this unit was tested using a 1" (25mm) non-combustible hearth pad with a thermal conductivity, (k) = 0.47 BTU - in/hr - ft² - °F, resulting in the requirement of providing a total thermal resistance (R) of 2.12. (Refer to "How to Determine if alternate Floor Protection Materials are Acceptable" section.) The floor protector may be covered with a decorative noncombustible material if desired. Do not obstruct the space under the heater. An 8" chimney and chimney connector is required and the bypass damper must be in the fully open position.

Important: All installations on a combustible floor require the use of the supplied bottom heat shield.

Protection requirements vary somewhat between the United States and Canada as follows:

In U. S. installations the floor protector is required under the stove and must extend at least 16" (not including the ash lip) from the front of the stove ("F", Figure 12), and at least 6" from the sides and rear. ("D" and "E", Figure 12)

In rear venting configurations, floor protection must also extend under the chimney connector and 2" to either side. ("C", Figure 12) For the 8" (203 mm) connector, the protector must be a minimum of 12" (305 mm) wide. For the 6" (152 mm) connector, the protector must be 10" (254 mm) wide. The protector must be centered under the connector.

To meet these requirements, a floor protector must be at least 44" wide and 46" deep.

In Canada: A noncombustible floor protector is required under the stove as well. The floor protector must extend 18" (457 mm) to the front ("F", Figure 12), and 8" (203 mm) from the sides and rear. ("D" and "E", Figure 12)

To meet these requirements, a floor protector must be at least 46" (1168 mm) wide and 50" (1270 mm) deep.

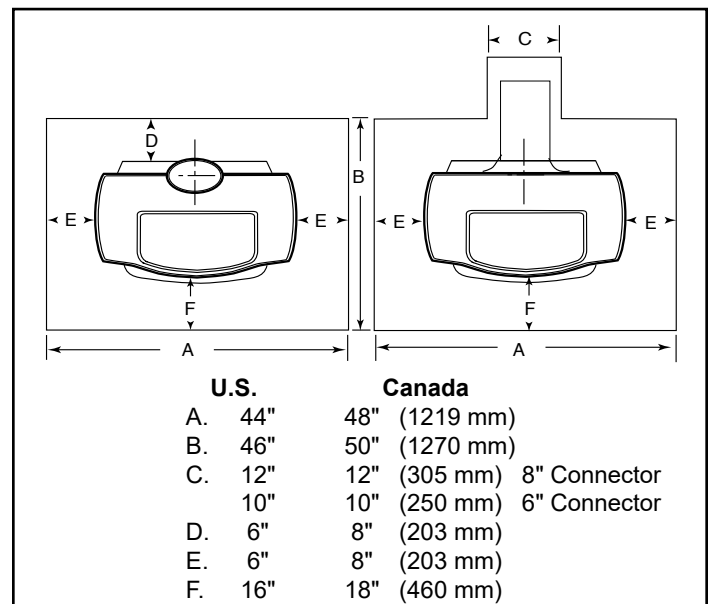

Figure 12 - Required floor protection dimensions.

How to Determine if Alternate Floor Protection Materials are Acceptable

All floor protection must be noncombustible (i.e. metals, brick, stone, mineral fiber boards, etc.). Any organic materials (i.e. plastics, wood paper products, etc.) are combustible and must not be used. The floor protection specified includes some form of thermal designation such as R-value (thermal resistance) or k-factor (thermal conductivity).

Procedure:

- Convert specifications to R-value:
 - R-value given - no conversion needed.
 - k-factor is given with a required thickness (T) in inches:
$$R = \frac{1}{k} \times T$$
 - K-factor is given with a required thickness (T) in inches:
$$R = \frac{1}{K \times 12} \times T$$
 - r-factor is given with a required thickness (T) in inches:
$$R = r \times T$$
- Determine the R-value of the proposed alternate floor protector:
 - Use the formula in Step 1 to convert values not expressed as R.
 - For multiple layers, add R-values of each layer to determine overall R-value.
- If the overall R-value of the system is greater than the R-value of the specified floor protector, the alternate is acceptable.

EXAMPLE: The specified floor protector should be 1/2-inch thick material with k-factor of 0.84. The proposed alternate is 4" brick with an r-factor of 0.2 over 1/8" mineral board with a k-factor of 0.29

Step a: Use formula above to convert specification to R-value:

$$R = \frac{1}{k} \times T = \frac{1}{0.84} \times 0.5 = 0.59$$

Step b: Calculate R of proposed system.

4" brick of r = 0.2, therefore:

$$R_{\text{brick}} = 0.2 \times 4 = 0.8$$

1/8" mineral board of k = 0.29, therefore

$$R_{\text{mineralboard}} = \frac{1}{0.29} \times 0.125 = 0.431$$

$$R_{\text{total}} = R_{\text{brick}} + R_{\text{mineralboard}} = 0.8 + 0.431 = 1.231$$

Step c: Compare proposed system R_{total} of 1.231 to specified R of 0.59. Since proposed system R_{total} is greater than required, the system is acceptable.

Definitions:

$$R = \frac{(\text{ft}^2)(\text{hr})(^\circ\text{F})}{\text{Btu}} \quad k = \frac{(\text{Btu})(\text{in})}{(\text{ft}^2)(\text{hr})(^\circ\text{F})} = K \times 12$$

$$K = \frac{(\text{Btu})(\text{ft})}{(\text{ft}^2)(\text{hr})(^\circ\text{F})} \quad r = \frac{(\text{ft}^2)(\text{hr})(^\circ\text{F})}{(\text{Btu})(\text{in})} = \frac{1}{k}$$

Floor Protection for Fireplace Installation

Do not assume that your fireplace hearth is completely noncombustible. Many fireplace hearths do not satisfy the "completely noncombustible" requirement because the brick or concrete in front of the fireplace opening is supported by heavy wood framing. Because heat passes readily through brick or concrete, it can easily pass through to the wood. As a result, such fireplace hearths can be a fire hazard and are considered a combustible floor.

For all fireplace installations, follow the floor protection guidelines described above, including the need for a bottom shield. Keep in mind that many raised hearths will extend less than the required clearance from the front of the heater. In such cases, sufficient floor protection as described above must be added in front of the hearth to satisfy the minimum floor protector requirement from the front of the stove: 16" (410 mm) in the United States and 18" (460 mm) in Canada. Hearth rugs do not satisfy the requirement for floor protection as they are not fire proof.

Fireplace installations also have special clearance requirements to the side walls, side decorative trim and fireplace mantel. Refer to the information on fireplace and mantel trim shields in this section.

Keep the Stove a Safe Distance From Surrounding Materials

Both a stove and its chimney connector radiate heat in all directions when operating, and nearby combustible materials can overheat dangerously if they are too close to the heat source. A safe installation requires that adequate clearance be maintained between the hot stove and its connector and nearby combustibles.

Clearance is the distance between either your stove or chimney connector, and nearby walls, floors, the ceiling, and any other fixed combustible surface. The Defiant® has specific clearance requirements that have been established after careful research and testing. These clearance requirements must be strictly observed.

In addition, keep furnishings and other combustible materials away from the stove. In general, a distance of 48" (1219 mm) must be maintained between the stove and movable combustible items such as drying clothes, furniture, newspapers, firewood, etc. Keeping those clearance areas empty assures that nearby surfaces and objects will not overheat.

Safe Ways to Reduce Clearances

Clearance requirements are established to meet every installation possibility, and they involve the combination of these variables:

- When the stove pipe has no listed heat shield mounted on it.
- When the wall has no heat shield mounted on it.
- When the wall has a heat shield mounted on it.
- When the wall and stove pipe have heat shields.

In general, the greatest clearance is required when you place a stove and its connector near a wall with no heat shield.

For example, when the Defiant® is installed parallel to the rear wall and no connector shield is used, it must be at least 15" (381 mm) from the wall behind it and at least 21" (533 mm) from walls on either side. These dimensions are measured from the top edge of the stove to the combustible wall.

If the Defiant® is installed in a corner and no shield is used, the corners of the stove top must be at least 5" (127 mm) from nearby walls.

Clearances may be reduced only by means approved by the regulatory authority, and in accordance with the clearances listed in this manual. Refer to Page 14 for approved clearance reduction specifications.

NOTE: A minimum of 67" (170 cm) from the top of the stove to the ceiling is required for all installations of the Defiant®.

NOTE: Installation of the Defiant® is not permitted in alcoves.

Wall Shields

One way to reduce clearances is with a wall shield constructed of 24 gauge or heavier sheet metal, or of another noncombustible material such as 1/2" (13 mm) insulation board such as Durock® or Wonderboard®, or common brick "laid on flat," with the 3 1/2" (90 mm) side down.

Shields must be spaced out from the combustible surface 1" (25 mm) on noncombustible spacers, as in Figure 13. The spacers should not be directly behind the stove or chimney connector.

Air must be able to flow between the wall and the shield. At least 50% of the bottom 1" (25 mm) of the shield must be open, and the shield must be open at the top. Metal screening across the top will keep small stray objects from being trapped behind the shield. (Figure 13)

The shield must be a minimum of 48" (1219 mm) tall, and must extend at least 19" (483 mm) higher than the top of the stove, whichever is higher. The shield behind the chimney connector must be 30" (760 mm) wide, centered behind the pipe; for installations that use an approved prefabricated chimney to pass through the ceiling, the shield behind the chimney connector must stop 1" (25 mm) below the ceiling.

With 8" connections and chimneys, because of potentially higher pipe temperatures, the shield must extend the full height of the wall (up to 9' (2.7 m)) and stop 1" (25 mm) below the ceiling.

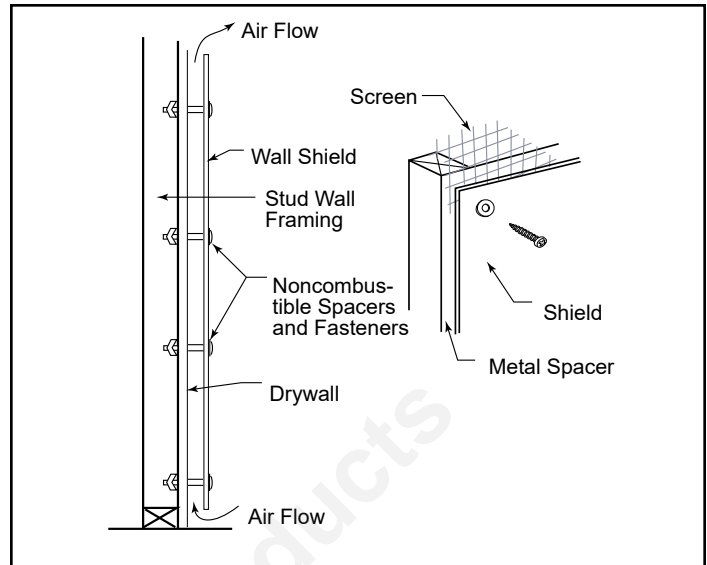

Figure 13 - Approved wall shield construction.

Fireplace and Mantel Trim Shields

A fireplace installation requires special clearance between the side of the stove and the right and left walls, between the side of the stove and the decorative side trim on the fireplace face, and between the top of the stove and the mantel.

Noncombustible shields installed 1" (25 mm) away from the combustible surface on noncombustible spacers, called ventilated shields, may be used to reduce clearances.

To protect a mantel from the heat of a stove in a fireplace installation, use a custom-made ventilated mantel shield that is at least 48" (1220 mm) long, centered over the stove. (Figure 14) Ventilated shields for side trim must extend the full length of the trim.

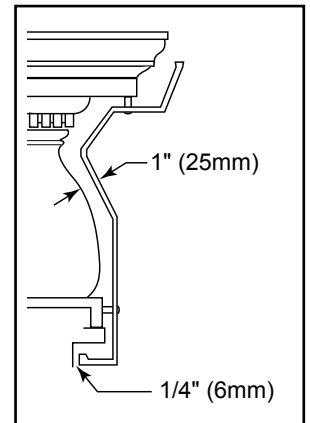

Figure 14 - A custom-formed mantel shield.

An unprotected mantel ("A", Figure 15) cannot be more than 9" (230 mm) deep and must have a minimum clearance of 41" (1041 mm), measured from the stove's top plate. With a ventilated shield, this clearance may be reduced safely to 29" (737 mm).

Unprotected top trim (B) protruding 3/4" (19 mm) or less from the face of the fireplace must be a minimum of 28" (711 mm) from the stove's top surface. With a ventilated trim shield, this clearance may be reduced safely to 21" (533 mm).

Unprotected side trim (C) that protrudes 3/4" (19 mm) or less from the face of a fireplace must have a minimum clearance of 14" (356 mm), measured from the stove's top side edge. If the trim extends more than 3/4" (19 mm), it is subject to the requirements for wall clearance.

The charts and sample installations that follow list all the clearances required for the various installation configurations of the Defiant®.

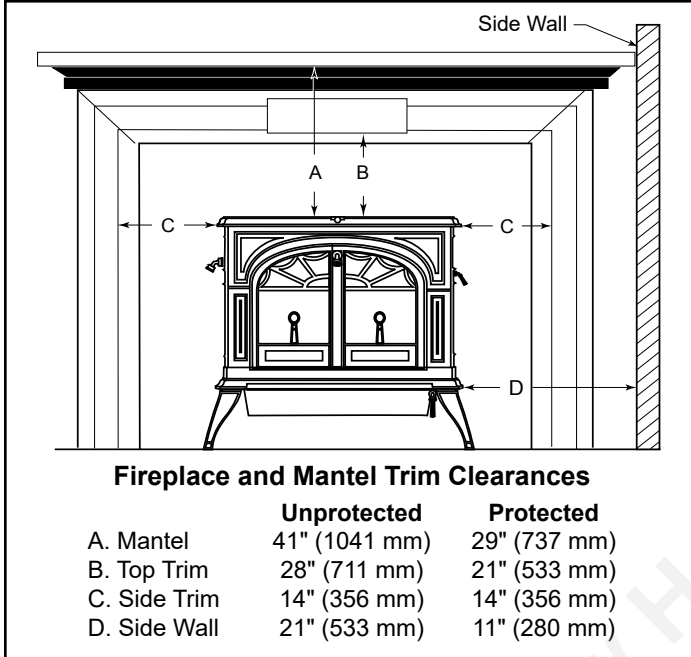

Figure 15 - Maintain clearances to combustible components of the mantelpiece.

Defiant® Clearance Chart for 6" and 8" Connections ONLY

	Stove Clearance							
	Unprotected Surface No Connector Heat Shield				Protected Surfaces ¹ with Connector Heat Shield			
	Stove Installed Parallel to Wall			Stove in Corner	Stove Installed Parallel to Wall			Stove in Corner
	Side	Rear ²		Corners	Side	Rear ²		Corners
		(to rear shroud)	(to back edge of cast)			(to rear shroud)	(to back edge of cast)	
Top exit with single wall connector pipe	(A) 21" (521 mm)	(B) 15" (381 mm)	(C) 21" (521 mm)	(D) 5" (127 mm)	(E) 5" (127 mm)	(F) 3" (76 mm)	(G) 9" (229 mm)	(D) 5" (127 mm)
Door open with fire screen used and damper open (8" chimney only) ²	(H) 22" (559 mm)	(I) 18" (457 mm)	(J) 24" (610 mm)	N/A	N/A	N/A	N/A	N/A
Top Exit with Double wall ³ connector pipe	(P) 21" (521 mm)	(Q) 15" (381 mm)	(R) 21" (521 mm)	(S) 5" (127 mm)	(T) 5" (127 mm)	(U) 3" (76 mm)	(V) 9" (229 mm)	(W) 2" (51 mm)
Rear Exit	(X) 21" (521 mm)	(Y) 10" (254 mm)	(Z) 16" (407 mm)	N/A	N/A	N/A	N/A	N/A

The attached rear shroud must be used in all installations. The flue collar heat shield must be used in all vertical installations.

1. The connector pipe heat shield must extend 36" (914 mm) above the flue collar.
2. **WARNING:** If stove has been installed based on the clearances described above as "Top exit with single wall or double wall connector pipe," then stove cannot be operated as "Door open with fire screen and damper open" without moving the stove so the clearance meets those described for this type installation.
3. Using a listed double wall oval to round connector.
4. A minimum of 67" (170 cm) from the top of the stove to the ceiling is required for all installations of the Defiant®.

A ceiling heat shield, 24" (610 mm) in diameter and suspended 1" (25 mm) from the ceiling must surround the pipe in installations where the chimney penetrates the ceiling.

Defiant® Clearance Diagrams

for use with either a 6" or 8" chimney connection

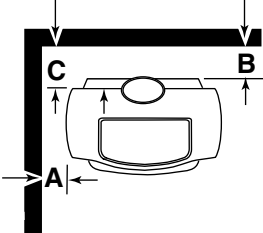
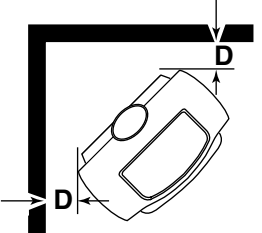
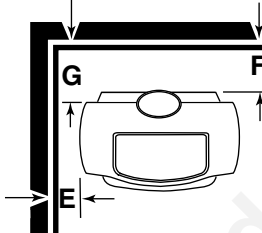
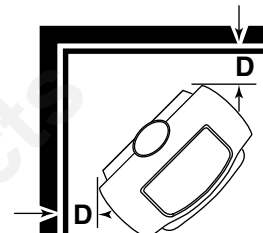
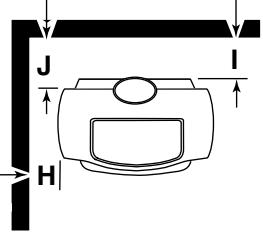
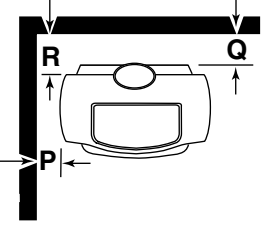
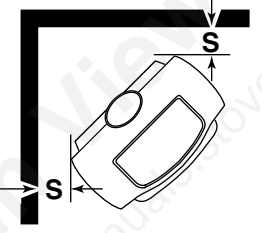
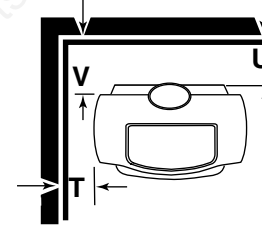
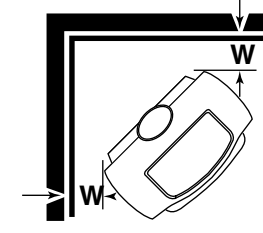
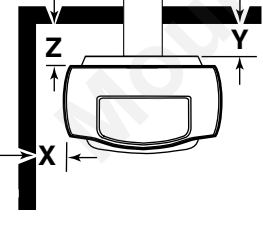
Unprotected Surfaces No Connector Heat Shield		Protected Surfaces with Connector Heat Shield	
Stove Installed Parallel to Wall	Stove in Corner	Stove Installed Parallel to Wall	Stove in Corner
Top Exit Installations, single-wall connector			
			
Door open with fire screen, damper open, 8" chimney only, 1" floor protection			
	N/A	N/A	N/A
Top Exit Installations, double-wall chimney connector, flue collar shield installed			
			
Rear Exit Installations			
	N/A	N/A	N/A

Distance from the Center of the Flue Collar to the Wall

Single Wall - No Connector Heat Shields					
Unprotected Surface			Protected Surface		
Parallel Installations		Corner Installations	Parallel Installations		Corner Installations
Side (A)	Rear (B)	Corner (C)	Side (D)	Rear (E)	Corner (F)
36-1/2" (927 mm)	21" (533 mm)	16" (406 mm)	20-1/2" (521 mm)	9" (229 mm)	16" (406 mm)

Doors Open - 8" Connector		
Unprotected Surfaces		
Parallel Installations		Corner Installations
Side (A)	Rear (B)	Corner (C)
37-1/2" (953 mm)	18" (457 mm)	

Double Wall Connector					
Side (A)	Rear (B)	Corner (C)	Side (D)	Rear (E)	Corner (F)
36-1/2" (927 mm)	21" (533 mm)	16" (406 mm)	20-1/2" (521 mm)	9" (229 mm)	16" (406 mm)

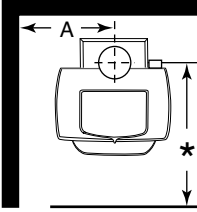
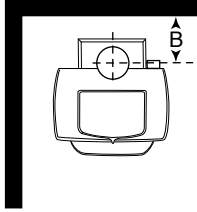
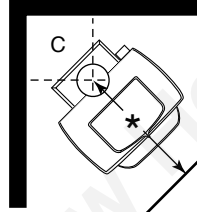
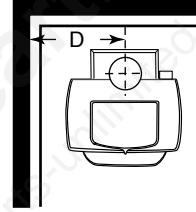
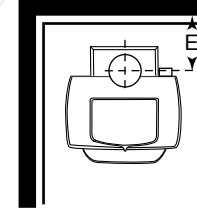
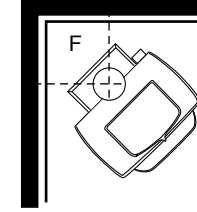
* This distance, from the center of the flue collar to the front edge of the hearth, is the same for all installations on this page: 34" (865 mm) in the United States and 36" (914 mm) in Canada.

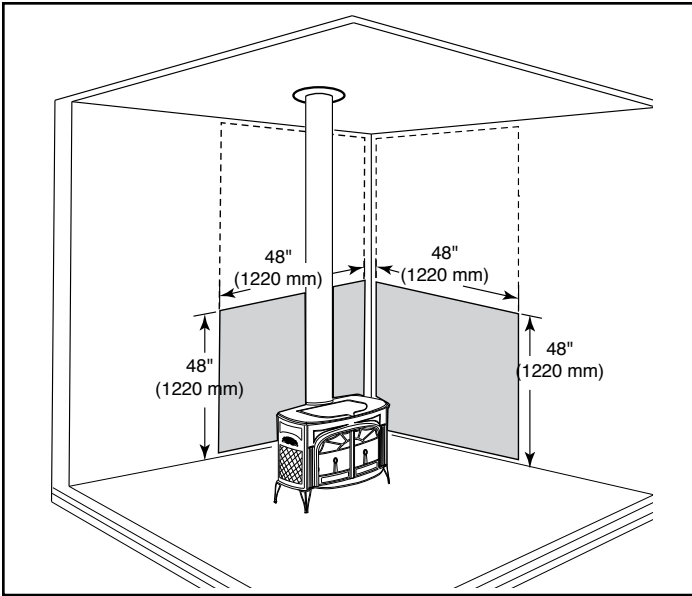

Figure 16 - Parallel installation, vertical chimney connector, two wall shields. Reduced clearances for both rear and side walls. Wall shields may meet at corner if desired. Shielding for connector is centered behind connector.

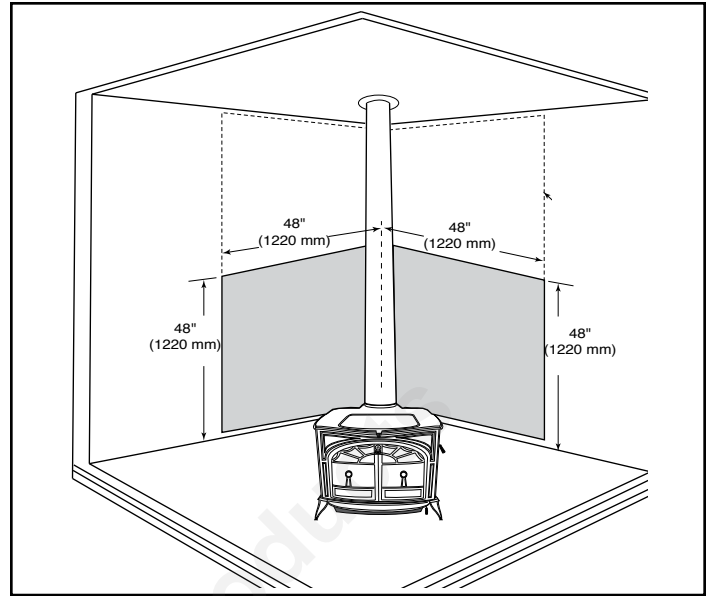

Figure 18 - Corner installation, vertical chimney connector, two wall shields. Reduced side clearances. Wall shield **MUST** meet at corner.

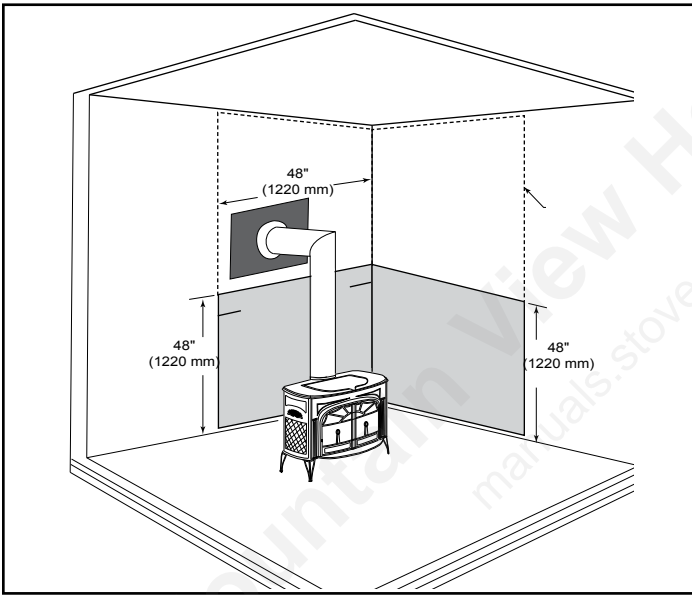

Figure 17 - Parallel installation with rear wall pass-through, two wall shields. Reduced clearances to both rear and side walls. Wall shields may meet at corner if desired. Wall pass-through must comply with codes.

Refer to "Special Installations."

Assembly

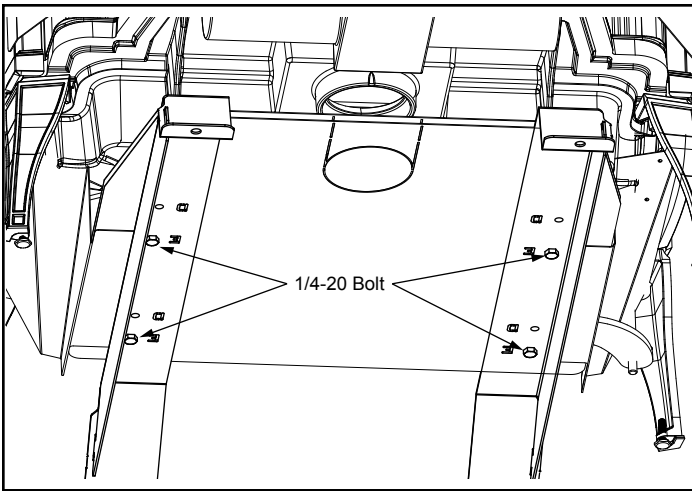

Figure 19 - Remove unit from shipping brackets.

Remove the unit from the shipping brackets by removing (2) 1/4-20 hex head bolts from each shipping bracket, leaving brackets attached to the skid. Figure 19. (Save the 1/4-20 hex head bolts as they will be needed later to install heat shield.)

NOTE: When moving the stove, lift the stove to take weight off the legs whenever possible. Dragging or sliding the stove, especially across rough surfaces can cause the legs to loosen or even break.

Set Up Your Stove

Cast iron stoves are heavy, and it will take two to four people to move your Defiant® into position.

Wipe the protective coating of oil from the griddle with a clean dry rag or a paper towel.

Install the handle on the griddle. First, place the griddle upside down at the edge of a flat surface and assemble the handle. Figure 20.

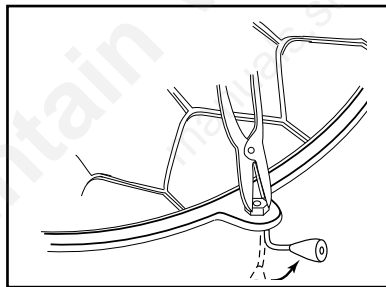

Figure 20 - Attach the griddle handle.

With the handle pointing 45° from its final position, tighten the nut as far as possible with the pliers. Move the handle to its final position while still holding the nut with the pliers.



CAUTION

Overtightening can strip tapped threads.

Storing the Handle

Use the removable handle to open or close the doors. After using it, remove the handle so it will not get hot. Store the handle in the handle holder installed behind the right front leg. (Figure 21)

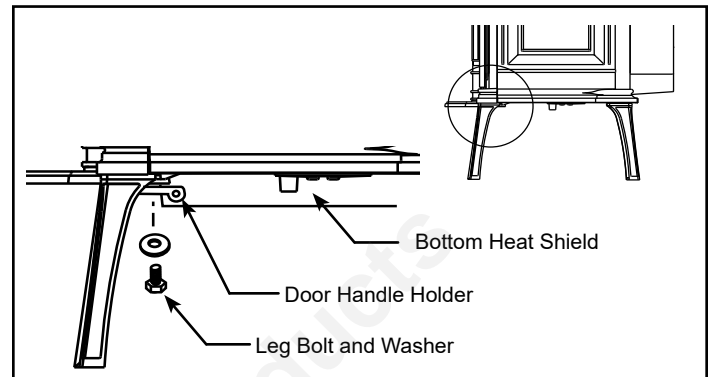

Figure 21 - Handle holder and heat shield positions.

Install the Bottom Heat Shield

NOTE: The Bottom Heat Shield is required in most installations. Refer to Floor Protection, Page 9, for further details.

1. Install (4) 1/4-20 x 3/8" hex bolts supplied in the manual bag into the four holes located under the stove (Figure 22).
2. Align the bottom heat shield key holes to the four hex bolts previously installed into base. (Figure 22). The outside air cutout hole should be toward the rear of the stove.
3. Attach the heat shield sides by passing the slots over the bolt heads. Tighten the hex head bolts. Figure 22.

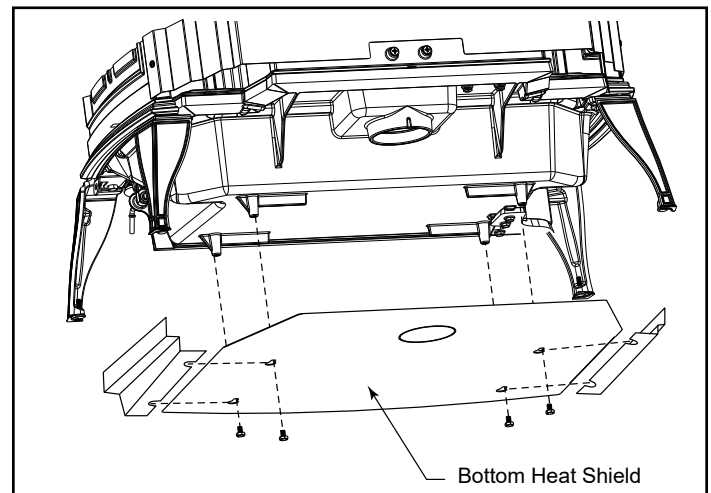

Figure 22 - Attach the bottom heat shield.

Adjust the Leg Levelers

Lift the stove slightly so there is no weight on the leg while making the adjustment.

Reverse the Flue Collar (If necessary)

Reverse the flue collar by removing the two screws that attach it to the back of the stove. Be sure the gasket around the flue collar opening is in position when you screw the collar back onto the stove.

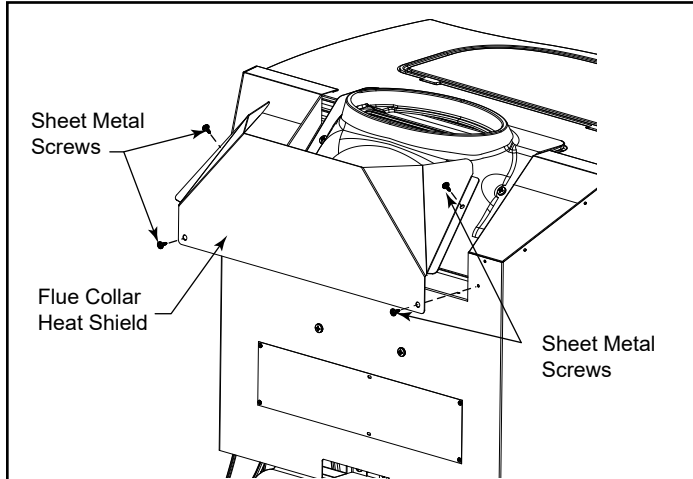

Figure 23 - Install flue collar heat shield.



WARNING

Flue collar heat shield must be installed.

Attach the Catalyst Temperature Probe

To install the catalyst temperature probe, remove the hole plug from the cast iron wall behind the rear shield as shown (Figure 24) use two #10 sheet metal screws and bracket supplied, secure the bracket and probe to the back of your stove. (Figure 24)

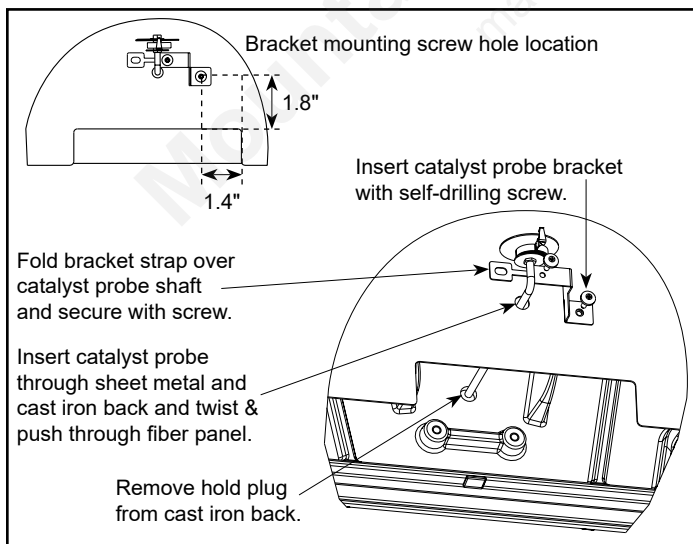

Figure 24 - Install the Catalyst Temperature Probe

Attach the Damper Handle

Use the 1/4"-20 x 3" screw to attach the damper handle to the damper stub on the left side.

Attach the Primary Air Thermostat Handle

The primary air thermostat handle is the smaller of the two black handles. Secure the handle to the stub on the right side of the stove with an 8-32 x 2" slot head machine screw. (Figure 25)

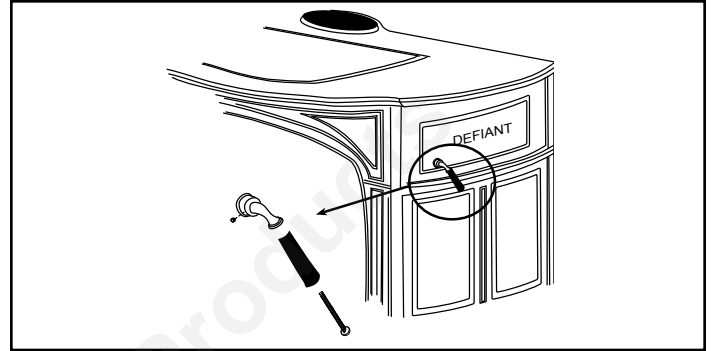

Figure 25 - Attach the thermostat handle.

Assemble the Removable Insert Handle

The wooden removable insert handle opens and closes the front doors. Remove after each use, and store it in the handle holder behind the right front leg. Assemble the handle by passing the 3-3/8" screw through the wooden shaft and into the bright metal nub. (Figure 26) Tighten carefully until snug.

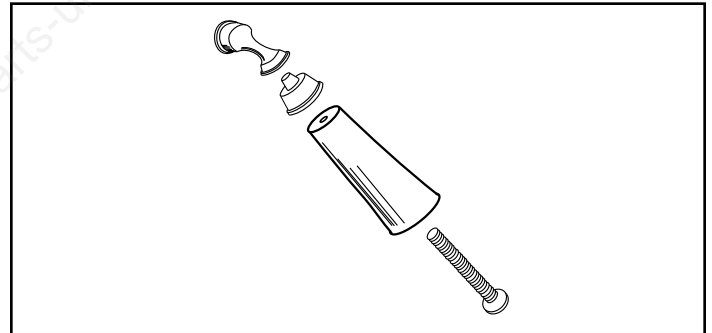

Figure 26 - Assemble the front door handle.

Fan Kit Installation

1. Attach the fan assembly at the bottom edge of the inner back with two (2) 1/4-20 x 3/4" hex head screws.
2. Attach snapstat to the mounting holes on the underside of the bottom with two (2) 1/4-20 pan head screws.
3. Attach the rheostat holder (provided with the stove) under the right front wing of the bottom heat shield with two (2) #10 sheet metal screws.
4. Attach the rheostat to its holder by inserting the rheostat control shaft through the holder hole. Install the retaining ring and rheostat knob onto the shaft.
5. Secure the rheostat cable to the underside of the bottom heat shield using the wire tie provided and the hole at the right rear edge of the heat shield.
6. Fan will not operate until stove reaches approximately 109°F.

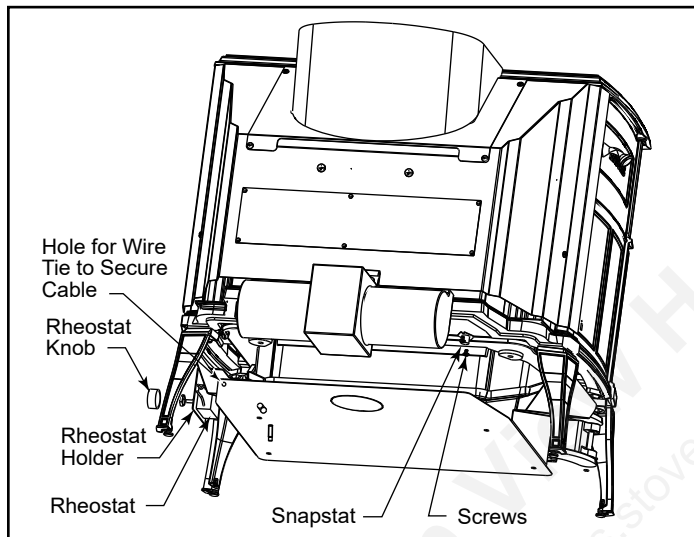

Figure 27 - Fan installation (Kit # 2767).

Installing or Removing Catalyst

1. Remove the access cover by gently lifting up and pulling out from the bottom edge. (Figure 28)
2. Remove the inner cover by pulling it straight out. (Figure 29)
3. Remove the catalyst by gently pulling it straight out. (Figure 30) Place the catalyst where the catalyst's ceramic components will not be damaged.



Figure 28 - Remove access cover.

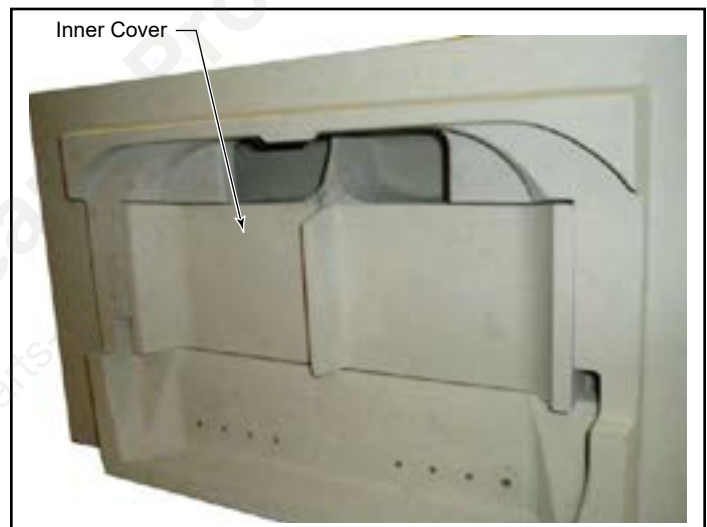

Figure 29 - Remove inner cover.



Figure 30 - Remove catalyst.

Smoke and CO Detectors

The use of smoke and carbon monoxide (CO) detectors throughout the home is strongly advised, even if not required by building codes or insurance regulations. It is a good idea to install a smoke detector in the living areas and each bedroom. Follow the smoke/CO detector manufacturer's placement and installation instructions and maintain regularly.

You may not, however, wish to install a detector in the immediate vicinity of the stove. Depending on the sensitivity of the unit, the alarm can be set off while you are tending the fire or emptying the ashes. If you install a detector in the same room, locate it as far away from the stove as possible.

Safety Tips

Conveniently locate a "Class A" fire extinguisher to contend with small fires. Be sure the fire extinguisher works and is clearly visible. All occupants of the house should know where it is, and how it operates. Have heavy stove gloves available near the stove. Have special safety accessories (e.g., Child Guard Screen) available for use if small children will be in the home.

In the event of a stove pipe or chimney fire....

- Evacuate the house immediately
- Notify the fire department
- If the fire isn't too threatening, closing down the stove tight, (damper, primary air, all doors) will help to smother the fire.
- Inspect your stove, stove pipe and chimney for any damage caused by the fire and correct any damage before using your stove again.

Operation

The Defiant® Controls:

Two controls regulate the performance of the Defiant®: a **primary air control** supplies oxygen for the fire, and a **damper** directs air flow within the stove to activate and deactivate the combustion system. (Figure 31)

Symbols cast into the stove are reminders of the correct directions for using the controls. The words 'Left' and 'right' in these directions are *facing the stove*.

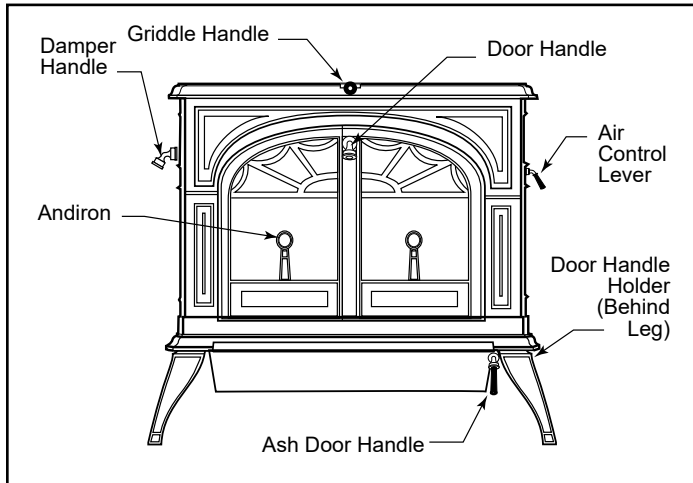

Figure 31 - The Defiant®'s controls are conveniently located and easy to operate.

A Single Air Control Regulates Heat Output and Burn Time

The **primary air control lever**, on the right side of the stove, controls the amount of incoming air for starting, maintaining, and reviving a fire.

Once the air control is manually set, a bi-metallic thermostat automatically maintains the heat output at a constant level for a more even heat over the life of the burn.

More air entering the stove makes the fire burn hotter and faster, while less air prolongs the burn at a lower heat output level. (Figure 32)

For the greatest air supply and maximum heat output (but the shortest burn time), move the lever toward the front of the stove. For a fire that will last longer with less heat, move the lever toward the rear of the stove.



WARNING

This wood heater has a manufactured-set minimum low burn rate that must not be altered. It is against federal regulations to alter this setting or otherwise operate this wood heater in a manner inconsistent with operating instructions in this manual.

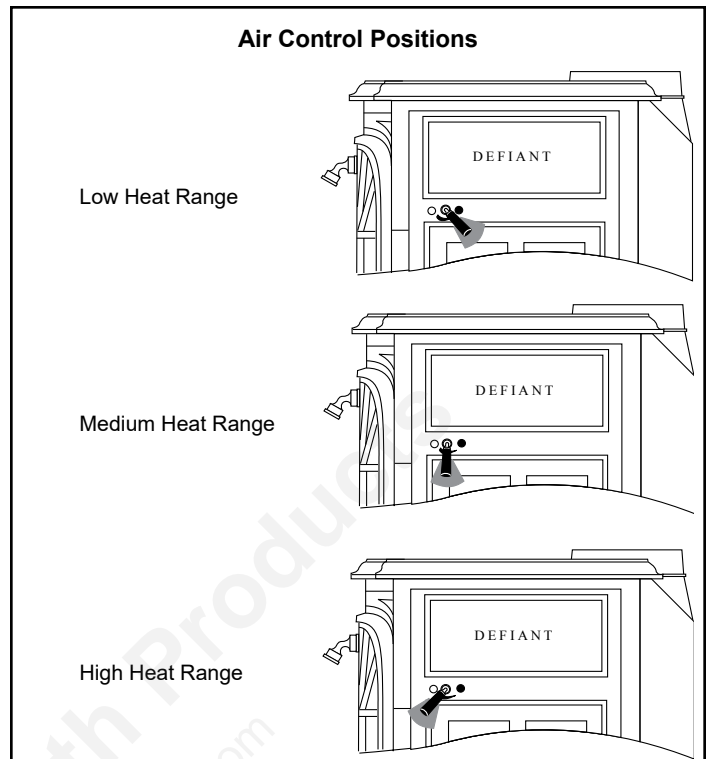

Figure 32 - The handle also may be positioned anywhere between the two extremes for different heat levels.

A Damper Directs Air Flow Within the Stove

The **damper handle** on the left side of the stove operates the damper to direct air flow within the stove.

The damper is **open** when the handle points to the **rear**, enabling smoke to pass directly into the chimney. The damper must be open when starting or reviving a fire, and whenever the griddle or doors are opened.

The damper is **closed** when the handle points **forward**. Smoke travels through the secondary combustion system where it can be further burned, before passing up the chimney. (Figure 33)

The damper should always be either fully open or fully closed. There are no intermediate positions. When closing the damper, be sure to pull firmly enough to snap the handle into the locked position.

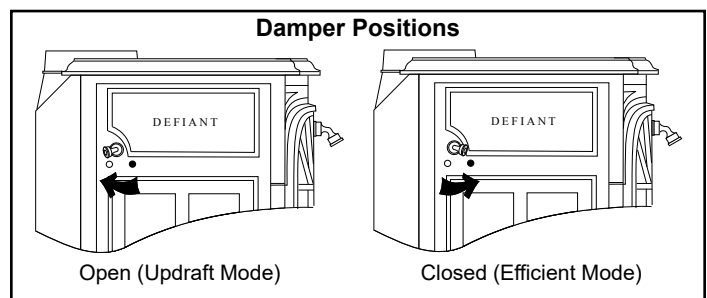

Figure 33 - The Defiant®'s damper operating positions.

Conditioning Your Stove

Cast iron is extremely strong, but it can be broken with a sharp blow from a hammer or from the thermal shock of rapid and extreme temperature change.

The cast plates expand and contract with changes in temperature. When you first begin using your Defiant®, minimize thermal stress by letting the plates adjust gradually during three or four initial break-in fires following Steps 1-3 below.

Wood Burning Operation

Burn only solid wood in the Defiant®, and burn it directly on the grate. Do not elevate the fuel. Do not burn coal or other fuels. In the United States, it is against the law to operate this wood heater in a manner inconsistent with operating instructions in this manual.

The bypass damper must be open when starting a fire or when refueling.

Do not use chemicals or fluids to start the fire. Do not burn garbage. Never use flammable fluids such as gasoline, gasoline type lantern fuel, kerosene, charcoal lighter fluid, naphtha, engine oil or similar liquids to start or "freshen up" a fire in this heater. Keep all such liquids well away from the heater while it is in use.

1. Open the stove bypass damper, and open the primary air control fully.
2. Place several sheets of crumpled newspaper in the stove. Place six or eight pieces of dry kindling split to a finger-width size on the paper. On the kindling, lay two or three larger sticks of split dry wood approximately 1-2" (25-51 mm) in diameter. (Figure 34)

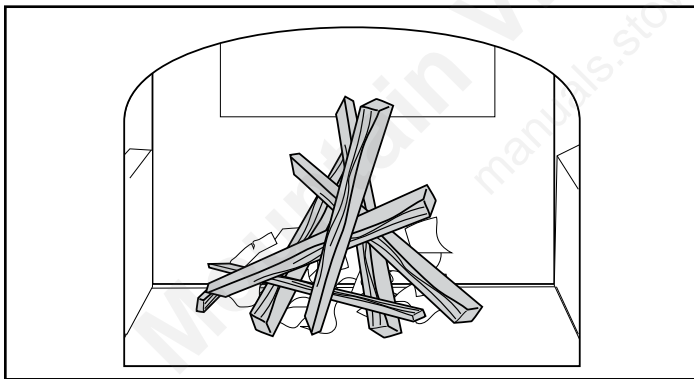

Figure 34 - Start the fire with newspaper and dry kindling.

3. Light the newspaper and close the door. Gradually build up the fire by adding a few 3-5" (80-120 mm) diameter pieces of split firewood. **If this is one of the first few "break-in" fires, let the fire burn brightly, and then let it die out.** During the break-in fires, do not let the stove get hotter than 500°F. (260°C) as measured on an optional stove-top thermometer. Adjust the air control lever as necessary to control the fire. Some odor from the stove's hot metal and the paint is normal for the first few fires.

NOTE: Some chimneys must be "primed", or warmed up, before they will draw sufficiently to start a fire. To correct this situation, roll up a couple pieces of newspaper, place them on top of the kindling and toward the back of the stove, light them, and close the doors. This will encourage the smoke to rise rapidly, making it easier to establish a good draft. Once the draft is established, open the front door and light the rest of the fuel from the bottom. Do not light the main bed of fuel until the chimney begins drawing, and repeat the procedure as often as necessary if the initial attempt is unsuccessful.

NOTE: Effectiveness of a "top-down" method to start a fire. Smoke emissions when starting a fire can be difficult to control because the stove is not yet heated to its optimum temperature. One method of reducing emissions during a cold start-up is the use of a "top-down" kindling procedure. In this, place larger pieces of kindling on the bottom of the kindling pile followed by smaller and smaller pieces as the pile is added to. Very finely split pieces should be on the top. Light the kindling pile with a match at the top and allow the kindling to burn downward into the larger pieces. This reduces smoke by slowly increasing the fire size without creating an air-starved condition.

4. **If your Defiant® has been broken-in previously** using Steps 1-3, continue to build the fire gradually. Add larger wood with a diameter of 3-4" (75-100 mm). Continue adding split logs of this size to the briskly-burning fire until there is a glowing ember bed 2-3" (51-75 mm) deep. (Figure 38) A good ember bed is necessary for proper functioning of the combustion system.
5. Close the damper when the griddle temperature reaches 450°F (230°C) and sufficient ember bed is established. This will force the smoke into the secondary combustion chamber where the smoke and gases will ignite if the stove is sufficiently hot. Even though it is possible for the fire to get quite hot within a few minutes after a fire is started, secondary combustion may stop or the fire may go out if the fire dies down immediately as a result of the damper being closed too early.
6. Adjust the air control for your desired heat output.

NOTE: Stove installations vary widely, and the operating guidance given here is only a starting point. The "Draft Management" section in this manual will explain in detail how the features of your installation may help or hinder good draft, and how you may need to vary your firing technique if your installation doesn't encourage a good draft.

High-Efficiency Wood Burning with the Catalytic Combustor
Your Defiant stove was shipped from the factory with a separately packaged catalytic combustor. When operating the stove with the catalytic combustor, use the same operation instructions as outlined in the previous section.

While not required, operating your stove with the catalytic combustor installed creates optimum conditions for secondary combustion and will increase your efficiency up to 15% on low burn, making sure you get the most heat out of each load of wood. Refer back to the *"Installing or Removing Catalyst"* section of this manual.

The catalytic element is a ceramic "honeycomb" coated with the catalytic material. The element sits at the bottom of the secondary combustion chamber. Smoke, gases and particulates that are not fully combusted during the secondary combustion process pass through the catalyst, creating a tertiary burn. This results in higher efficiency and lower emissions.

The catalyst will initiate combustion of smoke and particulates at 500° - 600°F (260° - 315°C), half the temperature normally required for unaided secondary combustion. If you followed the startup operation steps in the previous section the stove will be sufficiently hot to allow the combustor to work. Once the combustor starts working, heat generated by burning the smoke will keep it working.

To determine whether the combustor is operating, refer to the temperature probe which shows the operating range of the catalytic combustor. This is located on the back of the stove and is viewed from the top. **NOTE:** It will take several minutes after closing the bypass damper for the temperature probe to fully adjust to the new temperature. If the probe indicator is below the operate catalyst range, add fuel or open the bypass damper to allow the fire to further build before engaging the catalyst again.

If the probe indicator is above the operate catalyst range, the catalytic combustor is running too hot and may be damaged. In many cases, decreasing the primary air can reduce the catalyst temperature and adding less wood with each loading can also help if overheating is persistent. Do not add wood to the stove if the probe reads above the operate catalyst range.

Avoid using a full load of very dry wood in the firebox, such as dry slab wood or wood with below 14% moisture content. This may result in continuous very high temperatures in the secondary combustion area and damage the combustor.

Never kindle a fire with colored paper or paper that has colored ink or a glossy surface. Never burn treated wood, garbage, solvents or trash. All of these may poison the catalyst and prevent it from operating properly. Never burn cardboard or loose paper except for kindling purposes. Never burn coal; doing so can produce soot or large flakes of char or fly ash that can coat the combustor and cause smoke to spill into the room. Coal smoke can also poison the catalyst so that it won't operate properly.

NOTE: The ceramic catalytic combustor is fragile and will crack if subjected to thermal shock. Thermal shock can occur when refueling with wet wood or closing the bypass damper too early after refueling. Hairline cracks will not affect the performance of the combustor, but repeated thermal shocks can result in cells falling out, somewhat reducing the effectiveness of the combustor.

Two Ways to Add Fuel

The Defiant®'s griddle lifts for convenient top-loading of logs, and is the easiest way to add fuel. (Figure 35)

However, the front doors open as well for adding an occasional log to a fire. If the stove is equipped with 8" (203 mm) stove pipe, the front doors may be opened (or even removed) and the optional Defiant® spark screen placed in the opening for open-fire viewing. The Defiant® is not approved for operation with the front doors open if equipped with a 6" (152 mm) chimney connector or chimney.

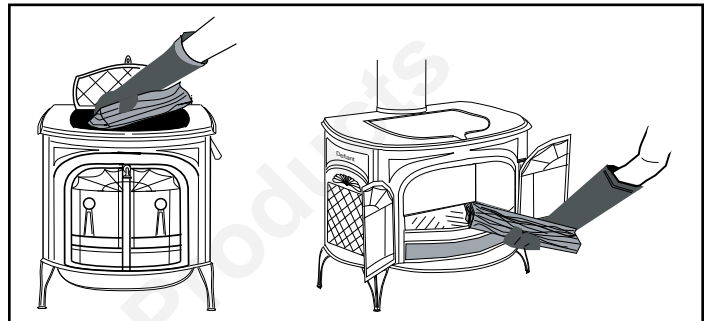

Figure 35 - Top loading is the best way to add fuel during regular use. Front loading is useful for kindling a fire.

To open the front doors, insert the handle into the door latch stub and turn it to the left and up. (Figure 36)

To close them, always close the left door first. Turn the handle in the right door to the left and up (to the open position) and close it. Finally, push on the door as you turn the handle to the right and down. The doors will draw in slightly, and the handle should offer some resistance as you turn it to the closed position.

To reduce the risk of breaking the glass, avoid striking the glass or slamming the doors.

When you are not using the door handle, store it in the holder behind the right front leg of the stove.

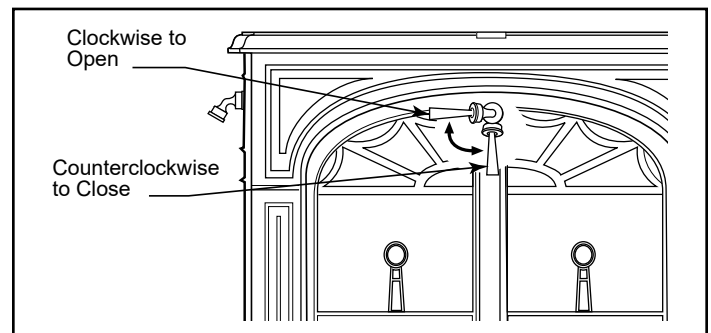

Figure 36 - To open the front doors, turn the handle clockwise.

WARNING

Fireplace stoves equipped with doors should be operated only with doors fully open or doors fully closed. If doors are left partly open, gas and flame may be drawn out of the fireplace stove opening, creating risks from both fire and smoke.



WARNING

For safety and greatest efficiency, operate your stove only with all doors/griddles fully closed. The test standard for your stove when it is operated in this mode is UL 1482.

The Defiant® may be used as a fireplace with the front doors open or removed, **BUT only when it is equipped with 8" (203 mm) stove pipe and only when the optional spark screen is secured correctly in the opening to protect against the possibility of sparks and embers leaving the stove.** The test standard for your stove when it is operated in this mode is UL 737. 1" floor protection is also required. Refer to the "Floor Protection" section in this manual.

Use only the Defiant® spark screen, Item #1907, with your Defiant®.

Defiant® SPARK SCREENS ARE AVAILABLE FROM YOUR VERMONT CASTINGS DEALER.

Refuel While the Embers Are Still Hot

When reloading, best results will be achieved if you first de-ash the stove by stirring the fuel bed to allow ash to fall through the grate into the ash pan.

Do not break the charcoal into very small pieces or pound or compress the charcoal bed. Check to make sure air holes at the bottom of the fireback are not blocked by ash or embers (blockage will reduce performance of the stove).

It is important that air can circulate through the charcoal bed during the burn. Larger pieces of charcoal allow more air to circulate under the wood, resulting in the fire reviving more quickly. (Figure 37)

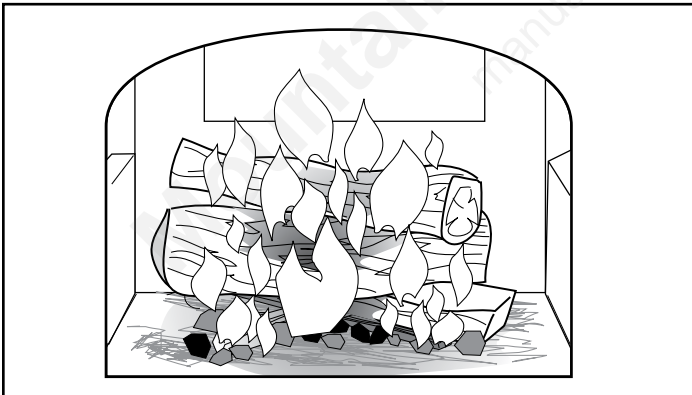

Figure 37 - Add full size logs after the ember bed is 3" (75mm) deep.

For best results when refueling, wear long-cuffed stove gloves to protect your hands and forearms. Add fuel while the stove still has plenty of glowing embers to re-ignite the fire and include some smaller pieces of wood in the new fuel load to help the stove regain its operating temperature quickly. Use this sequence as a guide to successful refueling:

1. Open the damper and turn the primary air control to high.
2. De-ash the stove as described above. Open the ash door and check the level of ash in the ash pan. Empty the pan if necessary and replace it in the stove. Close the ash door.
3. Open the griddle top, load the wood (smaller pieces first), and close the griddle top.
4. Wait several minutes for the new wood to fully ignite and for the stove top surface temperature to reach 450°F (230°C).
5. Close the damper. And adjust the air control for the amount of heat your desire.

NOTE: If the remaining charcoal bed is relatively thick (2-3"/51-75 mm) and if your fuel is well seasoned, it is possible to add fresh fuel (smaller pieces first), close the door and damper, and reset the primary air control for the desired heat output within five minutes.



WARNING

DO NOT OPERATE THE STOVE WITH THE ASH DOOR OPEN. OPERATION WITH THE ASH DOOR OPEN CAN CAUSE AN OVER-FIRING CONDITION TO OCCUR. OVER-FIRING THE STOVE IS DANGEROUS AND CAN RESULT IN PROPERTY DAMAGE, INJURY OR LOSS OF LIFE.

Andirons Help Protect the Glass

Your stove has andirons to keep logs away from the glass panels. The andirons are essential to maintain clear fire viewing, and should be left permanently in place. Since the andirons may slightly hinder refueling through the front doors, most stove owners will prefer the convenience of top loading through the griddle. Do not place fuel between the andirons and the doors.

Burn Only High-Quality Wood

The Defiant® is designed to burn natural wood only; do not burn fuels other than that for which it was designed.

IMPORTANT: Do not burn any type of artificial or synthetic materials such as fire starter logs (containing wax) in this appliance. Never burn liquid-based fuels such as kerosene, gasoline or alcohol.

Burning any materials not allowed in these instructions, or over-firing the stove, may void the warranty.

You'll enjoy the best results when burning wood that has been adequately air-dried. The wood should be 20-24" (457-508 mm) in length. Avoid burning "green" wood that has not been properly seasoned. Do not burn construction materials; they often contain chemicals and metals that can damage the inside surfaces of the stove and pollute the air. Do not burn ocean driftwood; when it burns, the salt it contains will attack the cast iron.

The best hardwood fuels include oak, maple, beech, ash, and hickory that has been split, stacked, and air-dried outside under cover for at least one year.

If hardwood is not available, you can burn softwoods that include tamarack, yellow pine, white pine, Eastern red cedar, fir, and redwood. These should also be properly dried.

Store split wood under cover to keep it dry. Even for short-term storage, be sure to keep wood a safe distance from the heater and keep it out of the areas around the heater used for refueling and ash removal.

Surface Thermometer is a Valuable Guide to Operation

An optional surface thermometer tells you when to adjust the air control, and when to refuel. (Figure 38)

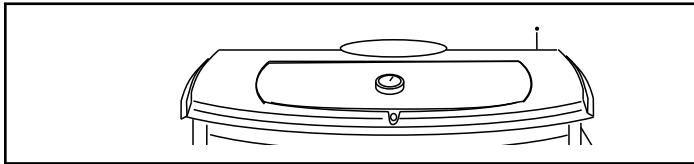

Figure 38 - Take temperature readings with a thermometer located in the middle of the griddle.

For example, when the thermometer registers at least 450°F (230°C) on the stove top after start-up you know the stove is hot enough and it may be time to close the damper if a sufficient ember bed has also been established. Note that the stove will warm up much sooner than the chimney, though; a warm chimney is the key to easy, effective stove operation. Please review the *"Draft Management"* section of this manual to see how the size, type, and location of your chimney will affect your stove operation. When thermometer readings drop below 350°F. (175°C) it's time to adjust the air control for a higher burn rate or to reload the stove. A temperature reading over 650°F. (340°C) is a sign to reduce the air supply to slow the burn rate.

Use the following temperature ranges as a guide:

- Readings in the 350°-500°F. (175°-260°C) range indicate low to medium heat output.
- 500°-600°F. (260°-315°C) readings indicate medium heat output.
- Readings of 600°-650°F. (315-340°C) indicate high heat output. Operating your Defiant® continuously at griddle temperatures higher than 650° F (340°C) may damage the cast iron or enamel finish.

Use the Air Control Settings that Work Best for You

No single air control setting will fit every situation. Each installation will differ depending on the quality of the fuel, the amount of heat desired, and how long you wish the fire to burn; outdoor air temperature and pressure also affect draft.

The control setting also depends on your particular installation's *"draft"*, or the force that moves air from the stove up through the chimney. Draft is affected by such things as the length, type, and location of the chimney, local geography, nearby obstructions, and other factors. See the *"Draft Management"* section of this manual for details on how the installation affects performance.

Too much draft may cause excessive temperatures in the Defiant®, and could even damage the stove. On the other hand, too little draft can cause backpuffing into the room and/or the *"plugging"* of the chimney.

How do you know if your draft is excessively high or low? Symptoms of too much draft include an uncontrollable burn or a glowing-red stove part. Signs of weak draft are smoke leaking into the room through the stove or chimney connector joints or low heat output.

In some newer homes that are well-insulated and weather-tight, poor draft may result from an insufficient air supply in the house. In such instances, an open window near the stove on the windward side of the house can provide the combustion air supply needed.

Another option for getting more combustion air to the stove is to duct air directly from outside to the stove. In some areas provisions for outside combustion air are required in all new construction.

The Defiant® is equipped to deliver outside air for combustion. Adapter #3108 is required for installation and any 3" non combustible duct will need to be supplied by the installer.

When first using the stove, keep track of the air control settings. You will quickly find that a specific setting will give you a fixed amount of heat. It may take a week or two to determine the amount of heat and the length of burn you should expect from various settings.

Most installations do not require a large amount of combustion air, especially if adequate draft is available. Do not for any reason attempt to increase the firing of your heater by altering the air control adjustment range outlined in these directions.

Use the following air control settings as a starting point to help determine the best settings for your installation. Each is described as a fraction of the total distance the lever may be moved from right to left.

Defiant® Control Settings

(Refer to the first page of the Operation section.)

DO NOT OPERATE THE STOVE WITH THE ASH DOOR OPEN. OPERATION WITH THE ASH DOOR OPEN CAN CAUSE AN OVER-FIRING CONDITION TO OCCUR. OVER-FIRING THE STOVE IS DANGEROUS AND CAN RESULT IN PROPERTY DAMAGE, INJURY OR LOSS OF LIFE.

Ash Disposal

Routine ash removal is important for ease of maintenance, and is important for the stove's durability. Remove ash before it reaches the top of the ash pan. Check the level at least once a day. Every few days, clear any ash from the outer edges of the firebox. Most of the ash will fall through the grate. Stir the ash with a shovel or poker so that it falls through the grate slots.

IMPORTANT: Check the level of ash in the ash pan before reloading the stove. If the ash level is close to the top edge of the pan, empty the pan according to this procedure:

- Open the damper.
- Open the griddle or front doors, and use a shovel or poker to stir excess ash through the ash slots in the grate down into the ash pan.
- Close the griddle or doors, and unlatch the ash door. (Figure 39) It will pivot, swinging the ash pan out of the stove.

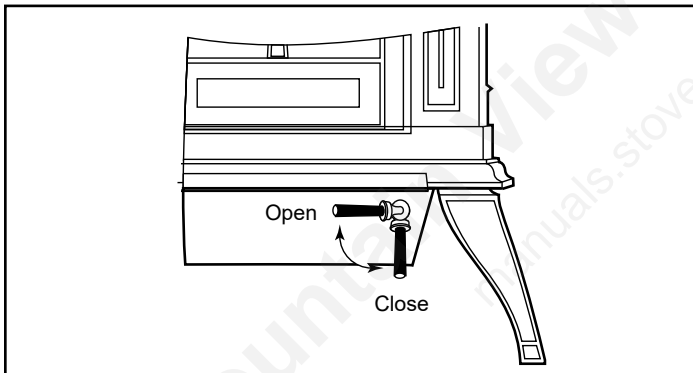

Figure 39- Turn the ashdoor handle clockwise to open and counterclockwise to close.

- Slide the cover onto the pan, making sure it is securely closed. (Figure 40)

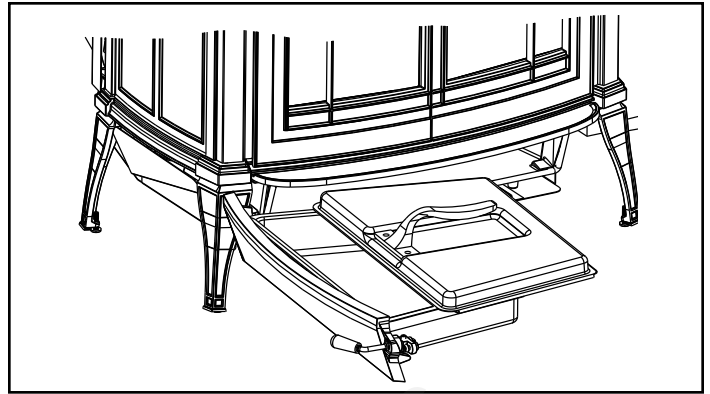

Figure 40 - Be sure the cover is securely attached before removing the ash pan.

- Remove the ash pan, making sure to keep it level.
- To keep the cover from sliding off and to keep ash from falling on the floor, do not tilt the ash pan forward.
- If the stove is in operation, close the ash door while disposing of the ash. You may need to lift the latch end of the door slightly to align the latch with the mating part on the stove bottom.
- Properly dispose of the ash in a metal container with a tight-fitting lid. Store the container outdoors away from all combustible material.
- Return the ash pan to its original position in the stove, and close and latch the ash door. (Figure 41)
- **Do not operate the stove with the ash door open. This will result in over-firing, and could cause damage to the stove, void the warranty, or even lead to a house fire.**

Empty the ash pan regularly, typically every one to three days. The frequency will vary depending on how you operate your Defiant®: ash will accumulate faster at higher heat outputs.

Removed ash should be placed outdoors in a metal container with a tight-fitting lid. Keep the closed container of ash on a noncombustible floor or on the ground, well away from all combustible materials, pending final disposal. If the ash is disposed of by burial in soil or otherwise locally dispersed, it should be kept in the closed container until all cinders have thoroughly cooled.

CAUTION

Never use your household or shop vacuum cleaner to remove ash from the stove; always remove and dispose of the ash properly.

Draft Management

A stove is part of a system, which includes the chimney, the operator, the fuel, and the home. The other parts of the system will affect how well the stove works. When there is a good match between all the parts, the system works well.

Wood stove or insert operation depends on natural (unforced) draft. Natural draft occurs when the exhaust is hotter (and therefore lighter) than the outdoor air at the top of the chimney. The bigger the temperature difference, the stronger the draft. As the hot gases rise through the chimney they provide suction or 'draw' that pulls air into the stove for combustion. A slow, lazy fire with the stove's air inlets fully open indicates a weak draft. A brisk fire, supported only by air entering the stove through the normal inlets, indicates a good draft. The stove's air inlets are passive; they regulate how much air can enter the stove, but they don't move air into it.

Depending on the features of your installation - steel or masonry chimney, inside or outside the house, matched to the stove's outlet or oversized - your system may warm up quickly, or it may take a while to warm up and operate well. With an 'airtight' stove, one which restricts the amount of air getting into the firebox, the chimney must keep the stove's exhaust warm all the way to the outdoors in order for the stove to work well. Some chimneys do this better than others. Here's a list of features and their effects.

Masonry Chimney

Masonry is a traditional material for chimneys, but it can perform poorly when it serves an 'airtight' stove. Masonry is a very effective 'heat sink' - it absorbs a lot of heat. It can cool the chimney gases enough to diminish draft. The bigger the chimney, the longer it takes to warm up. It's often very difficult to warm up an outdoor masonry chimney, especially an oversized one, and keep it warm enough to maintain an adequate draft.

Steel Chimney

Most factory-made steel chimneys have a layer of insulation around the inner flue. This insulation keeps the chimney warm. The insulation is less dense than masonry, so a steel chimney warms up more quickly than a masonry chimney. Steel doesn't have the good looks of masonry, but it performs much better.

Indoor/Outdoor Location

Because the chimney must keep the smoke warm, it's best to locate it inside the house. This uses the house as insulation for the flue and allows some heat release into the home. An indoor chimney won't lose its heat to the outdoors, so it takes less heat from the stove to heat it up and keep it warm.

Chimney Height

The common wisdom tells us that a taller flue draws better than a short one. This isn't necessarily so. If a chimney is tall enough to meet the safety requirements of the 2/3/10 foot rule, then adding more height isn't the right answer to a draft problem. In fact it could make the problem worse by adding more mass to the chimney system, which must be warmed up, a distance from the heat source (the stove). Don't make a chimney taller unless you must in order to meet the safety rules, or unless there's some nearby feature causing a downdraft. Even then, there are downdraft-preventing chimney caps available, which are probably the smarter choice.

Flue Sizing

The inside size of a chimney for an 'airtight' stove should match the size of the stove's flue outlet. When a chimney serves an airtight stove, more is not better; in fact, it can be a disadvantage. Hot gases lose heat faster as they travel slower through a chimney; if we vent a stove with a six-inch flue collar (28 square inch area) into a 10 x 10" flue, the gases slow to one third their original speed. This allows the gases to cool more rapidly, which weakens draft strength. If an oversized flue is also outside the house, the heat it absorbs gets transferred to the outdoor air and the flue usually stays cool.

It is common for a masonry flue, especially one serving a fireplace, to be oversized for the stove. It can take quite a while to warm up such a flue, and the results can be disappointing. The best solution to an oversized flue is an insulated steel chimney liner, the same diameter as the stove or inserts flue outlet; the liner keeps the exhaust warm, and the result is a stronger draft. A non-insulated liner is a second choice - the liner keeps the exhaust restricted to its original size, but the hot gases still must warm up the air around the liner. This makes the warm-up process take longer.

Pipe & Chimney Layout

Every turn the exhaust must take as it travels to the chimney top will slow it down. The ideal pipe and chimney layout is to vent vertically into a completely straight and vertical chimney. If you are starting from scratch, use this layout if possible. If the stovepipe must elbow to enter a chimney, locate the thimble about midway between the stove top and the ceiling. This achieves several goals: it allows the gases to speed up before they must turn, it leaves some pipe in the room for heat transfer, and it gives you long-term flexibility for installing a different stove without relocating the thimble.

There should be no more than eight feet of single-wall stove pipe between the stove and a chimney; longer runs can cool the exhaust enough to cause draft and creosote problems. With prefabricated chimney, bring it down to six to eight feet from the stove. With a masonry chimney, arrange the pipe so that it turns into the chimney within eight feet of the stove.

Single Venting

Each 'airtight' stove requires its own flue. If an airtight stove is vented to a flue that also serves an open fireplace, or a leakier stove, it's easier for the chimney draft to pull air in through those channels and performance of the stove suffers. Imagine a vacuum cleaner with a hole in the hose to understand the effect here. In some cases the other appliance can even cause a negative draft through the stove, and result in a dangerous draft reversal.

Creosote

Creosote is a by-product of slow wood-burning. It's an organic tar that can condense in the flue if it is present in the exhaust, slow-moving, and cools to less than 290°F (130°C). Condensed creosote is volatile, and can generate chimney fires if it gets hot enough. All the features that affect chimney draft also affect creosote condensation - so use whatever combination of installation features and operational steps that will encourage good draft and minimize creosote production.

Because letting the exhaust cool off and slow down is one of the keys to creosote accumulation, it makes sense to line a chimney to match the stove's outlet size, for safety reasons as well as performance. Canadian law requires a matching liner to serve any stove or insert vented through a fireplace chimney; in the US, the National Fire Protection Association (NFPA) recommends a chimney liner if the flue is more than three times bigger (in square area) than the outlet on the stove or insert. Some localities enforce the NFPA guidelines as part of their building codes.

Fuel

Even the best stove installation will not perform well with poor fuel. The best fuel is hardwood that has air-dried 12-18 months. Softwood burns, but not as long as hardwood. 'Green' wood has a lot of moisture in it; it will burn, but some of the heat potential is used to boil the extra moisture from the wood. This reduces the amount of heat that reaches your home and can contribute to a creosote problem. There are moisture meters available for firewood; you can also judge your wood by its appearance and weight. If you get it green, lift a piece and get a sense of its weight; it can lose a third or more of its weight as it dries. Also look at the ends of a log; as it dries it shrinks and often cracks. The more weathered and cracked a piece is, the drier it is.

Dry wood burns readily with a good chimney draft. But with modern stoves, wood can be too dry and too volatile. Smoke and combustible gases can 'gas out' from the wood quickly and densely enough to overload the combustion system. If you hear a rumbling or roaring noise (like a propane torch) from the stove, that is a sign that the stove is overfiring.

Back-puffing

Back-puffing results when the fire produces volatile gases faster than the chimney draft pulls them out of the firebox. The gases back up in the firebox until they are concentrated enough and hot enough to ignite. If your stove back-puffs, the stove needs to cool down. You should open the damper to let the smoke rise to the flue more quickly, allow more air into the firebox, avoid big loads of firewood and check that the wood moisture is not too low.

Draft Testing

An easy way to test your chimney draft is to close the stove's damper, wait a few minutes to let the airflow stabilize, then see whether you can vary the strength of the fire by swinging the air control open and closed. Results are not always instant; you may need to wait a few minutes for a change in the air control setting to have an effect on the fire. If there's no change, then the draft isn't strong enough yet to let you close the damper, and you'll need to open it for awhile longer and manage the fire with the air inlet until the draft strengthens. If you keep track of your burning habits and relate them to their effects on the stove's operation, you'll be rewarded with good performance and a safe system.

Negative Pressure

Good draft also depends on a supply of air to the stove; a chimney can't pull in more air than is available to it. Sluggish draft results when a house is tight enough to prevent the ready flow of air to the stove, or by competition between the stove and other equipment that sends indoor air outside - especially power-driven equipment like range hoods, clothes dryers, etc. If the chimney draws well with all other equipment turned off (or sealed, in the case of fireplaces and/or other stoves), then you simply need to be careful with timing the use of the other air consuming equipment. If you need to crack a nearby window or door to enable the chimney to flow well, it may be a good idea to install an outside-air intake to bring combustion air directly to the stove. An outside air kit is available to connect the stove directly to a source of outdoor combustion air.

Conclusion

Wood-burning is an art rather than a science. Once the stove and chimney system are in place, you can only vary your technique, mostly your timing, to achieve good results. If you keep track of your burning habits and relate them to their effects on the stove's operation, you'll be rewarded with good performance and year of reliable heating.

Maintenance

Keep Your Stove Looking New and Working Its Best

Let the fire in the stove go out and allow the stove to cool completely before beginning any maintenance procedure.

Care of the Cast Iron Surface

An occasional dusting with a dry rag will keep the painted cast iron of your Defiant® looking new.

The stove's paint can be touched up as needed. First, mask the areas, such as enameled parts, glass, or handles, around the spot to be painted. Clean the spot with a wire brush. Remove the griddle and set it aside. It is normal for the griddle to darken after use. You can clean it with a fine-bristle wire brush, or steel wool.

Then, touch up the stove with Vermont Castings' high temperature stove paint. Apply the paint sparingly; two light coats of paint are better than a single heavy one.

Care of the Porcelain Enamel Surface

Use a dry or slightly damp rag or soft brush to remove spills or stains. For difficult jobs that require a cleaning agent, use only a kitchen appliance cleaner or polish recommended for use on enamel surfaces.

If porcelain enamel becomes chipped or scratched during use, apply "enamel epoxy" to the damaged area and allow to dry. Once the epoxy has dried, sand the area to blend with surrounding area and apply appropriate color touch-up paint. Allow to dry completely before operating stove.

Cleaning the Glass

Most of the carbon deposits on the glass will burn off during hot fires.

However, the ash residue that accumulates on the glass surface should be removed regularly to prevent etching. To clean the glass, follow this procedure:

- Be sure the glass is completely cool.
- Clean the glass with water or a cleaner made especially for this purpose. Do not use abrasive cleaners. Use cleaning agents sparingly and be sure to keep them off the outer surfaces of the stove.
- Rinse the glass thoroughly.
- Dry the glass completely.

Adjusting Thermostat Control

The thermostat control is adjusted at the factory and should not be modified. In the unlikely event that adjustment is required, you will need a flathead screw driver and a pair of pliers. Locate the primary cover on the lower back portion of the stove (Figure 42). With pliers, bend the tabs to the straight position and use the flat head screw driver to pry the bracket out far enough to remove the cover. Once the cover is off, loosen the thumb screw with the primary handle in the closed position. Adjust the steel cable by either pulling slack out of the cable or allowing more in. Tighten the thumb screw and test the primary control by turning the handle to the open position and checking the position of the flap. There should not be any delay between the handle and the flap. Always ensure the flap will close completely.

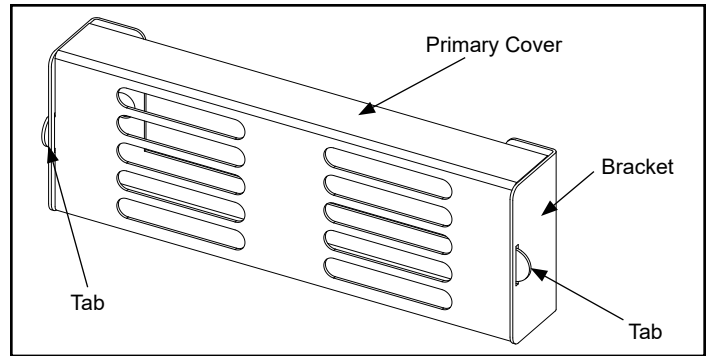

Figure 42 - Primary cover and Bracket.

Replace Broken Glass Immediately

Do not operate your stove if the glass in the doors is damaged.

If you need to replace the glass, use only the high temperature ceramic glass supplied by Vermont Castings. Do not use substitutes.

Removing the Glass

1. Remove the right and left door assemblies by raising the door until the lower hinge pin clears its hole; then, angle the door bottom slightly outward and pull down to release the upper hinge pin. Place the doors face down on a padded work surface. Be especially careful with enameled doors.
2. Remove the screws that hold the glass retainer clips in place, and remove the clips.
3. Carefully lift the broken glass panel from the door.

Installing the Glass

Check the gasket around the window; it should be soft and resilient so that the glass will seal properly against the door. Replace the gasket if it has hardened or if it is compressed.

1. Center the glass on the gasket.
2. Secure the glass on both doors with the retainer clips. Tighten all screws. (Figure 43)
3. Replace the doors on the stove.
4. Open and close the doors to check that they fit and work properly. Adjust as necessary.

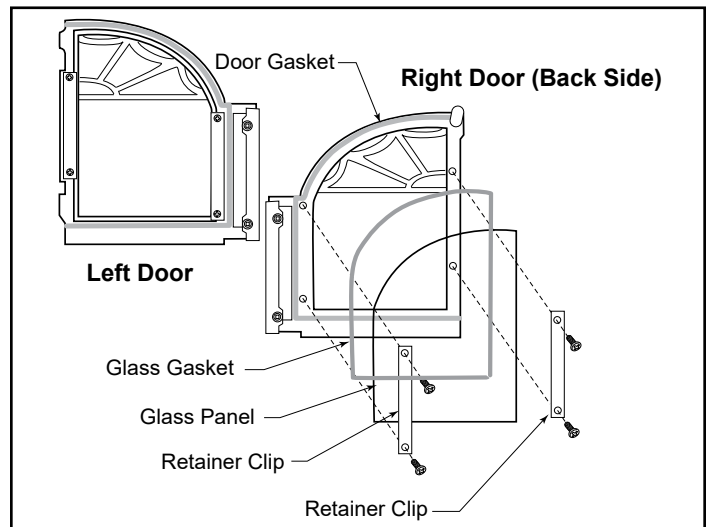

Figure 43 - An exploded view of the glass assembly.

Adjust the Damper as Needed

The tension on the Defiant®'s damper is adjustable to compensate for compression of the gasket that seals the damper to the upper fireback. To adjust the damper:

1. Remove the griddle. Loosen the lock nut at the center of the damper. (Figure 44)
2. Turn the pressure screw approximately one half turn clockwise with an Allen wrench provided with your stove.
3. Tighten the lock nut. Prevent the pressure screw from turning as you tighten the nut. Re-test the damper.

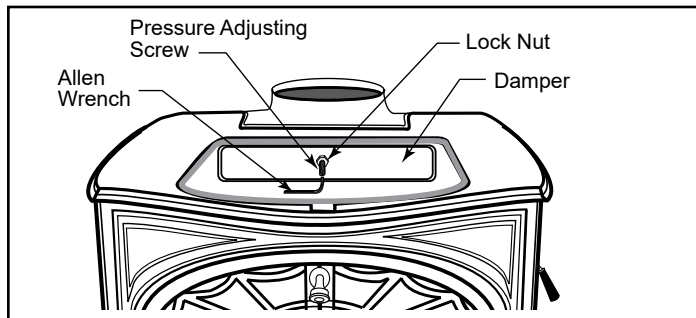

Figure 44 - Adjust the damper with the Allen wrench.

Tighten the Damper Handle as Needed

A handle on the left side of the stove controls the damper. The handle attaches to the damper rod with a set screw. Periodically check the set screw and tighten as necessary.

How to Adjust the Door Latches

The front door of the stove should close securely to prevent accidental opening and should close tightly to prevent air from leaking into the fire chamber. The door handle will be positioned vertically when the door is closed.

Over a period of time, the gasket around the door will compress and the latch may need adjustment. To adjust the handle, follow this procedure:

1. Remove and retain the lock nut with a 9/16" wrench. (Figure 45)
2. Loosen the set screw with a 1/8" Allen wrench.
3. Rotate the pawl 180°. Replace the lock nut. Tighten the set screw.
4. Additional adjustment can be made by removing the flat washer. Or any combination of washer removal and/or pawl rotation.

Test the door seal. Close the door on a dollar bill and attempt to pull it free. If the bill is freed with little resistance, the gasket isn't snug enough at that spot. Continue to make small adjustments until the setting is right.

If additional adjusting of the latch does not enable the door to seal sufficiently in one area, try "adjusting" the gasket in that area. Pack more cement or a smaller diameter gasket into the channel beneath the gasket so the main gasket is raised and makes contact with the door frame. If this procedure doesn't solve the problem, replace the gasket. Instructions for gasket replacement are given later in this section.

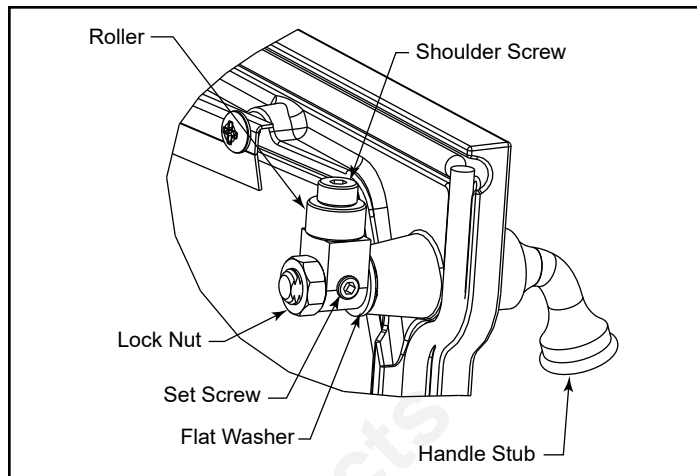

Figure 45 - Rotate pawl and/or remove flat washer to adjust latch.

Replace the Stove Gaskets as Needed

Your Defiant® uses fiberglass rope gaskets to make a tight seal between some parts. With use, particularly on moving parts, gaskets can become brittle and compressed and can begin to lose their effectiveness. These will need periodic replacement.

The sizes of replaceable gasket are listed below, along with their applications.

Gasket Diameter.....And the Parts it Seals

5/16" - The griddle to the stove top (wire reinforced gasket)

5/16" - The damper to the upper fireback

7/16" - The front doors to the stove front; and the doors to each other.

3/8" - The ash door to the front of the bottom panel

3/16" - The outer glass panes to the door

If you need to change a gasket, first obtain an appropriate replacement from your Vermont Castings' Authorized Dealer.

Wait until the fire is out and the stove has cooled. Be sure to follow the standard safety procedure for working with dusty materials: wear safety goggles and a dust mask.

The procedure for replacing gaskets is the same, regardless of the gasket location. Follow these steps:

1. Remove the existing gasket by grasping an end and pulling firmly. (Figure 46)
2. Use a wire brush or the tip of a screwdriver to clean the channel of any remaining cement or bits of gasket. Remove stubborn deposits of cement with a cold chisel if necessary. (Figure 46)

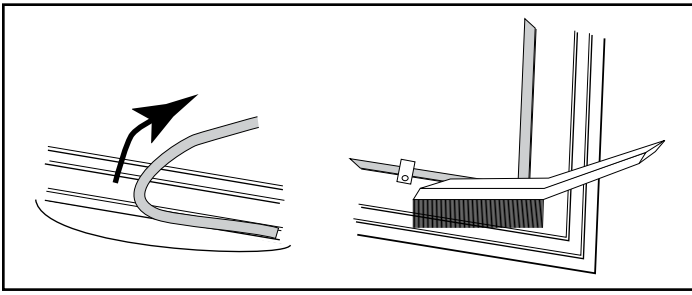

Figure 46 - Remove gasket then clean channel with wire brush.

3. Determine the correct length of the appropriate-sized gasket by laying it out in the channel. Allow an extra 1-2" (25-50 mm), and mark the spot to be cut.
4. Remove the gasket from the channel, place it on a wood cutting surface, and cut it at the marked spot with a utility knife. Twist the ends slightly to keep the gasket from unraveling.
5. Lay an unbroken 1/8" (3 mm) bead of silicone in the newly-cleaned channel. (Figure 47)

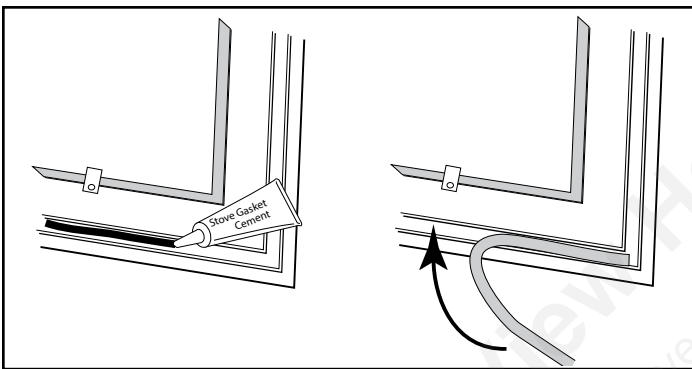

Figure 47 - Lay a bead of gasket cement then press gasket in place.

6. Starting at one end, press the gasket into the channel. (Figure 47) Ensure a good joint where the gasket meets before trimming any excess. Do not overlap the gasket ends or leave ends with ragged edges.
7. Press the gasketed part firmly against its normal mating surface to seat the gasket evenly in its channel. Close and latch the door to do this, or tap other parts with the rubber mallet (or hammer/block of wood).
8. Clean any excess cement from around the channel, then let the cement that holds the new gasket dry thoroughly.
9. The stove's doors may need adjustment after you have regasketed them. Initially, it may require loosening the latch to accommodate the new gasket; after a few weeks, it may need tightening to compensate for compression of the new gasket. The directions for adjusting the latches are on Page 30.

All Gasketed Construction Gaskets

Other gaskets form seals between all other non-moving parts, but these are not subject to the same wear and deterioration as gaskets on moving parts. It is unlikely that you will ever need to replace these gaskets unless the involved parts are disassembled and then put back together. If this is the case, the job should be done only by a qualified service technician.

5/16" diameter gasket seals the following parts:

- The lower fireback to the back panel
- The left and right air plates (inner sides)
- All connections between the stove plates.

The Chimney System

Creosote

Your Defiant® is designed to reduce creosote build-up significantly. However, regular chimney inspection and maintenance must still be performed. For safety, good stove performance, and to protect your chimney and chimney connector on a regular schedule. Clean the system if necessary. Failure to keep the chimney and connector system clean can result in a serious chimney fire.

When wood is burned slowly, it produces tar, organic vapors and moisture that combine to form creosote. The creosote vapors condense in the relatively cool chimney flue of a slow-burning fire. As a result, creosote residue accumulates on the flue lining. When ignited, this creosote makes an extremely hot fire within the flue system that can damage the chimney and overheat adjacent combustible material. If a significant layer of creosote has accumulated —1/8" (3 mm) or more — it should be removed to reduce the risk of a chimney fire.

You can never be too safe. Contact your local fire authority for information on what to do in the event of a chimney fire, and have a clearly understood plan on how to handle one.

If you do experience a chimney fire, act promptly to:

- Close the damper and air control lever.
- Get everyone out of the house.
- Call the Fire Department.

Inspect the system every two weeks during the heating season as part of a regular maintenance schedule. To inspect the chimney, let the stove cool completely. Then, using a mirror and a strong light, sight up through the flue collar into the chimney flue. If you cannot inspect the flue system in this fashion, the stove must be disconnected to provide better viewing access.

Clean the chimney using a brush the same size and shape as the flue liner. Flexible fiberglass rods are used to run the brush up and down the liner, causing any deposits to fall to the bottom of the chimney where they can be removed through the clean-out door.

Clean the chimney connector by disconnecting the sections, taking them outside, and removing any deposits with a stiff wire brush. Reinstall the connector sections after cleaning, being sure to secure the joints between individual sections with sheet metal screws.

If you cannot inspect or clean the chimney yourself, contact your local Vermont Castings dealer or a professional chimney sweep.

Maintenance Schedule

The Stove

Daily:

- Clear any ash build-up from around the air holes and combustion flow path in the lower fireback.
- Ashes should be removed before they reach the top of the ash pan. Check accumulation at least once a day.
- Keep the area around the stove clear of any combustible materials such as wood, furniture or clothing.

Two Months:

- Check door handle to be sure it is working properly. Gasketing becomes compressed after a period of time. Adjust handle tightness if necessary.
- Check leg bolts and heat shield screws; tighten if necessary.

Annual Spring Cleaning:

- Check gasketing for wear, and replace if necessary.
- Remove ashes from the ash pan and replace with a moisture absorbing material (such as kitty litter) to keep the interior of the stove dry.
- Clean the dust from the inner sides of bottom, rear or pipe heat shields if your stove is equipped with them. Clean surfaces are better heat reflectors than dirty surfaces.
- Touch up the black paint.
- Inspect for and remove ash build-up behind the combustion package. This should be done in conjunction with annual cleaning of the chimney connector. Inspect the passage behind the combustion package (a mirror will be helpful) and vacuum away ash using a flexible vacuum hose inserted in the passage. (Figure 48)

The Chimney Connector

Two Weeks:

- Inspect the chimney connector and chimney. Clean if necessary.

Two Months:

- Inspect the chimney and chimney connector. Pay particular attention to the horizontal runs of chimney connector, and the elbows. Clean the system if necessary.

Annual Spring Cleaning:

- Disassemble the chimney connector and take it outdoors for inspection and cleaning. Replace weak sections of connector.
- Inspect the chimney for signs of deterioration. Repairs to a masonry chimney should be made by a professional mason. Replace damaged sections of prefabricated chimney. Your local Vermont Castings dealer or a chimney sweep can help determine when replacement is necessary.
- Thoroughly clean the chimney.

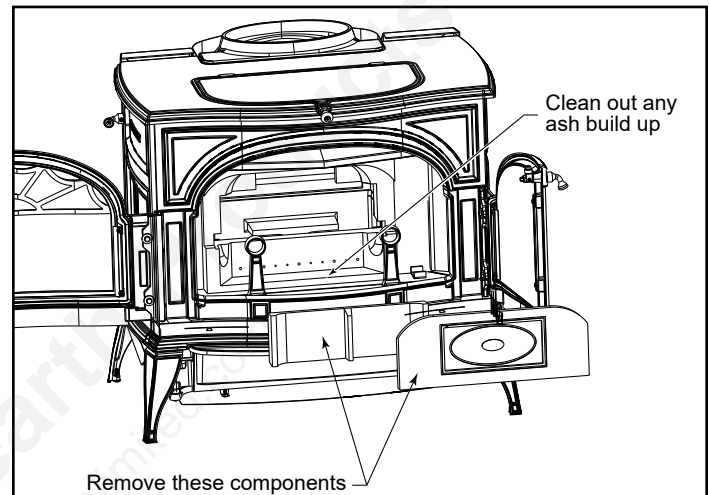

Figure 48 - Inspect and clean out ash accumulation behind the combustion system.

The Catalytic Element

This wood heater contains a catalytic combustor, which needs periodic inspection and replacement for proper operation. In the United States it is against the law to operate this wood heater in a manner inconsistent with the operating instructions in this manual.

Under normal operating conditions, the catalytic combustor should remain active for two to six years (depending on the amount of wood burned). However, it is important to monitor the combustor periodically to ensure that it is functioning properly, as well as to determine when it needs to be replaced. A non-functioning combustor will result in a loss of heating efficiency, and an increase in creosote and emissions.

Inspection and Cleaning

Inspect the combustor for fly ash accumulation and physical damage two to three times per year. Clean the combustor as needed.

The refractory package that houses the catalytic combustor should be inspected for a buildup of fly ash and cleaned if necessary. This may be done when you examine the combustor.

When to Suspect a Combustor Problem

The best way to evaluate the performance of your Defiant®'s combustor is to observe the amount of smoke leaving the chimney — both when the combustor has "lighted-off" and when it has not. Follow these steps:

- With a fire going and the combustor properly activated, with the damper closed to route smoke through it as described in the Operation Section, go outside and observe the smoke leaving the chimney.
- Then, open the stove damper and once again check the smoke leaving the chimney.

You should see significantly more smoke when the stove damper is open and exhaust does not pass through the combustor. However, be careful not to confuse smoke with steam from wet wood. Steam dissipates in the air quickly; smoke does not.

If this test indicates a problem, consider other possible factors as well, such as the weather or a change in the quality of your fuel. In warm weather, draft is weaker than it is in colder winter weather, and fires can burn sluggishly. Small, hot fires are a good solution under these conditions.

Burning "green" (insufficiently seasoned) wood will result in poorer performance than burning properly seasoned fuel. Reloading with green wood can also thermal shock the catalyst, resulting in cracking, or the eventual fallout, of the ceramic honeycomb substrate. You may have to run your stove hotter (more air) to achieve acceptable performance using green or wet wood.

NOTE: Burning wet wood increases the risk of thermally shocking the combustor, which can cause cracks in the ceramic substrate and fallout of individual cells.

Also, consider any changes in your operating routine.

Once you have ruled out any other possible causes for a decline in performance, inspect and clean the combustor if necessary. Be sure to protect any surface you use for setting the stove parts aside.

Inspecting the Combustor

Remove access door and inner fireback. Remove the catalytic combustor by lifting and sliding it towards you. (Figure 49)

To assure a long life for the combustor, it is recommended to service the combustor on a regular basis based on the amount of use. This procedure takes about five (5) minutes and requires no tools except for a vacuum if cleaning is necessary.

Cleaning the Combustor

1. Check the combustor's honeycomb-like element for a buildup of fly ash. If any is evident, take the combustor outside and clean it by blowing air gently through it. Do not push anything through the honeycomb; do not use compressed air to clear the passages. Such abrasion can scrape the thin coating of platinum (the catalyst) off the ceramic base, shortening the catalyst's life and reducing its effectiveness.

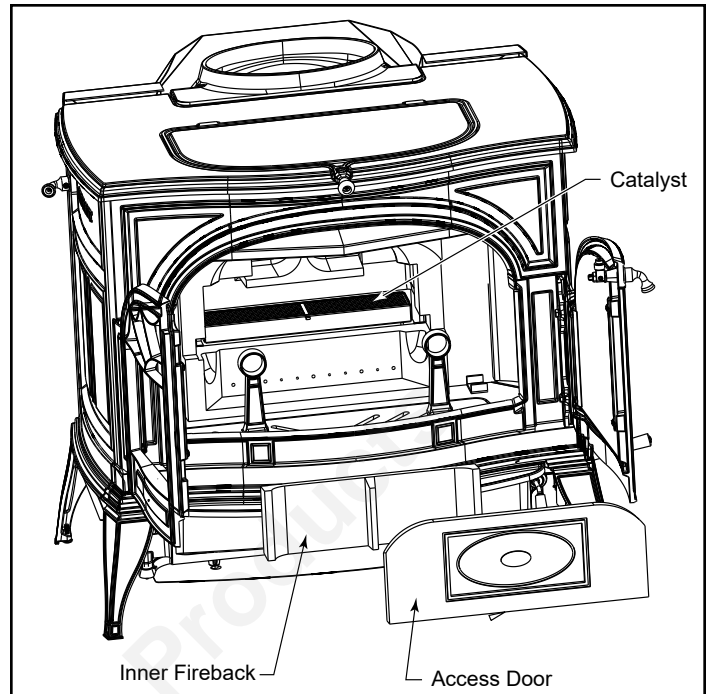

Figure 49 - Inspect the catalytic combustor.

2. Inspect the element for damage or degradation. Although small hairline cracks will not affect performance, the element should be essentially intact. If the element is broken in pieces or has sections missing, it should be replaced. Call your local Vermont Castings Authorized Dealer for a replacement element.
3. If the element is in good condition and clean, re-install it in the stove and replace the refractory inner fireback and access door.

Operate the stove in your usual manner for two weeks, inspecting the chimney and the chimney connector frequently during this period.

If creosote does not build up as fast, it is likely that the performance change was caused by fly ash deposits on the catalytic element. However, continue the inspections of the chimney system for a few weeks to ensure that proper performance continues.

If you continue to find a significant creosote buildup or if you continue to see excessive smoke from the chimney, the catalytic element will need to be replaced. Contact your nearest Vermont Castings' Authorized Dealer for information about a replacement element.

NOTE: Use only the replacement catalyst supplied by a Vermont Castings dealer.

Beginning Manufacturing Date: N/A
Ending Manufacturing Date: Active

- 0001975 (Classic Black)
- 0001976 (Biscuit)
- 0001977 (Majolica Brown)
- 0001979 (Bordeaux)
- 0001980 (Twilight)
- 0001975T (Classic Black w/Transition Doors)

- 0001978 (Ebony) (Ending Manufacturing Date: 2013)
- 0001976T (Biscuit w/Transition Doors) (End Manufacturing Date: March 2017)
- 0001977T (Majolica Brown w/Transition Doors)(End Manufacturing Date: March 2017)
- 0001979T (Bordeaux w/Transition Doors) (End Manufacturing Date: March 2017)
- 0001980T (Twilight w/Transition Doors) (End Manufacturing Date: March 2017)



Part number list on following page.

10/19

IMPORTANT: THIS IS DATED INFORMATION. Parts must be ordered from a dealer or distributor. **Hearth and Home Technologies does not sell directly to consumers.** Provide model number and serial number when requesting service parts from your dealer or distributor.



**Stocked
at Depot**

ITEM	DESCRIPTION	COMMENTS	PART NUMBER	Stocked at Depot
1	Brick Support Bracket		30005279	
2	Griddle Gasket	10 Ft	1-00-1203668	Y
3	Back		30005242A	
4	Refractory, Right End		30005206	
5	Refractory, Left End		30005207	
6	Refractory Support		30005233	
7	Gasket, Refractory Support		30005237	
8	Back Insulation Board		30005269	
9	Outer Back		30005249	
10	Griddle Quadrant, Left		30002399A	
11	Griddle Quadrant, Right		30002401A	
12	Griddle		30005257A	
13	Complete Griddle Handle Assembly		30002775	Y
13a	Griddle Handle, Wood		1600661	Y
13b	Griddle Handle, CRS-BN1		30002715	
13c	Nut, Hex 1/4-20	Pkg of 10	1203210-10	
14	Griddle Handle Bushing	Pkg of 10	1201900-10	
15	Griddle Handle Bolt	Pkg of 10	1201308-10	
16	Damper Gasket	15 Ft	1-00-1203588	Y
17	Damper Ramp		1300643	
18	Damper Housing		30002821A	
19	Damper		30002816	
20	Damper Tab	Pkg of 10	1601488-10	
21	Damper Rod		1600065	
23	Gasket, Back Refractory	10 Ft	1-00-30005270	
24	Rheostat Bracket		30002863	
25	Refractory, Engine - E/D		30005202	
26	Damper Handle Screw	Pkg of 10	1201310-10	
27	Damper Handle		1600664	Y
28	Damper Handle w/Screw Assembly		30002720A	Y
29	Left Side	Classic Black	30002832A	
		Biscuit	SRV30002872	
		Bordeaux	SRV30006697	
		Ebony	SRV30002892	
		Majolica Brown	SRV30004834	
		Twilight	SRV30007126	
30	Left Air Manifold		30002818	

Additional service part numbers appear on following page.

IMPORTANT: THIS IS DATED INFORMATION. Parts must be ordered from a dealer or distributor. **Hearth and Home Technologies does not sell directly to consumers.** Provide model number and serial number when requesting service parts from your dealer or distributor.



Stocked at Depot

ITEM	DESCRIPTION	COMMENTS	PART NUMBER	
31	Right Air Manifold		30005243	
32	Right Side	Classic Black	30002831A	
		Biscuit	SRV30002871	
		Bordeaux	SRV30006698	
		Ebony	SRV30002891	
		Majolica Brown	SRV30004835	
		Twilight	SRV30007127	
33	Thermostat Handle Base		30002716	Y
34	Washer Damper Rod	Pkg of 10	30007257-10	
35	Fireback Plate, S/S		30005217	
36	Inner Bottom		30005241	
37	Top Ashdoor Hinge	Pre 0081391652	30002836A	
		Post 0081391652	1-00-30002836	
38	Door Handle Bracket		30002844	
39	Bottom		30005240A	
40	Ashlip	Classic Black	30002811A	
		Biscuit	SRV30002870	
		Bordeaux	SRV30006696	
		Ebony	SRV30002890	
		Majolica Brown	SRV30004833	
		Twilight	SRV30007125	
41	Gasket, Fireback		30005209	
42	Refractory, Fireback		30005203	
43	Retainer, Fireback Refractory		30005248	
44	Refractory, Inner Cover		30005205	Y
45	Andiron		30002827A	Y
46	Refractory, Access Cover		30007252	
47	Leg Leveler	Pkg of 10	1201745-10	
48	Ashdoor Handle Shaft		30005301	
49	Pawl Assembly, 3/4 Short Adj.		30005157	Y
49a	Spring Washer	Pkg of 10	63D0069-10	
50	Ashdoor		30002810A	
50a	Ashdoor Gasket	15 Ft	1-00-1203589	
51	Ashdoor Handle, Wood		1600663	Y
52	Ashdoor Hinge Rod	Pre 0081391652	30002826	
	Hinge Hardware	Post 0081391652	1-00-2826	
53	Cotter Pin, Ashdoor (Pkg of 10)	Pre 0081391652	30001749-10	

Additional service part numbers appear on following page.

IMPORTANT: THIS IS DATED INFORMATION. Parts must be ordered from a dealer or distributor. **Hearth and Home Technologies does not sell directly to consumers.** Provide model number and serial number when requesting service parts from your dealer or distributor.



Stocked at Depot

ITEM	DESCRIPTION	COMMENTS	PART NUMBER	
54	Ashdoor Bottom Hinge Support	Pre 0081391652	1300642A	
		Post 0081391652	1-00-1300642	
55	Ashpan Bracket		30001908	
56	Rear Side Bracket		30002845	
57	Thermostat Handle		1600660	Y
58	Airwash Manifold, Front		30005244	
59	Front	Classic Black	30002830A	
		Biscuit	SRV30002873	
		Bordeaux	SRV30006699	
		Ebony	SRV30002893	
		Majolica Brown	SRV30004836	
		Twilight	SRV30007128	
60	Flue Collar Gasket		1-00-30002422	
61a	Left Door (Shell Enamel Parts)	Classic Black	30002813A	
		Biscuit	SRV30002876	
		Bordeaux	SRV30006703	
		Ebony	SRV30002896	
		Majolica Brown	SRV30004842	
		Twilight	SRV30007132	
	Left Door Sub Assembly (Shell Enamel Parts) (Does not contain glass or glass gasket)	Classic Black	30002854	
		Biscuit	30002879	
		Bordeaux	30006773	
		No longer available	30002899	
		Majolica Brown	30004840	
		Twilight	30007133	
61b	Left Door (Transition Door Enamel)	Classic Black	30007091A	
		Biscuit	SRV30007093	
		Bordeaux	SRV30007097	
		Majolica Brown	SRV30007095	
		Twilight	SRV30007109	
	Left Door Sub Assembly (Transition Door Enamel)	Classic Black	30007175	
		Biscuit	30007177	
		Bordeaux	30007179	
		Majolica Brown	30007181	
		Twilight	30007183	
62	Door Hinge Strip		1300645A	

Additional service part numbers appear on following page.

IMPORTANT: THIS IS DATED INFORMATION. Parts must be ordered from a dealer or distributor. **Hearth and Home Technologies does not sell directly to consumers.** Provide model number and serial number when requesting service parts from your dealer or distributor.



Stocked at Depot

ITEM	DESCRIPTION	COMMENTS	PART NUMBER	
63	Top	Classic Black	30002834A	
		Biscuit	SRV30002874	
		Bordeaux	SRV30006700	
		Ebony	SRV30002894	
		Majolica Brown	SRV30004837	
		Twilight	SRV30007129	
64	Glass Clip		30001715	
65	Glass Clip (Right Door Only)		30001716	
66	Front Door Handle and Shaft		30002717	Y
67a	Right Door (Shell Enamel Parts)	Classic Black	30002812A	
		Biscuit	SRV30002875	
		Bordeaux	SRV30006702	
		Ebony	SRV30002895	
		Majolica Brown	SRV30004841	
		Twilight	SRV30007131	
	Right Door Sub Assembly (Shell Enamel Parts) (Does not contain glass or glass gasket)	Classic Black	30002853	
		Biscuit	30002878	
		Bordeaux	30006772	
		No longer available	30002898	
		Majolica Brown	30004839	
		Twilight	30007134	
67b	Right Door (Transition Door Enamel)	Classic Black	30007090A	
		Biscuit	SRV30007092	
		Bordeaux	SRV30007096	
		Majolica Brown	SRV30007094	
		Twilight	SRV30007108	
	Right Door Sub Assembly (Transition Door Enamel)	Classic Black	30007176	
		Biscuit	30007178	
		Bordeaux	30007180	
		Majolica Brown	30007182	
		Twilight	30007184	
68	Door Gasket	15 Ft	1-00-7000910	Y
69	Glass Gasket	10 Ft	1-00-1186258229	Y
70	Left Door Glass		30005247	
71	Right Door Glass		30005247	
72	Lower Door Hinge Pin		30002727	Y
73	Spacer (For Damper Rod)	Pkg of 10	1201779-10	

Additional service part numbers appear on following page.

IMPORTANT: THIS IS DATED INFORMATION. Parts must be ordered from a dealer or distributor. **Hearth and Home Technologies does not sell directly to consumers.** Provide model number and serial number when requesting service parts from your dealer or distributor.



Stocked at Depot

ITEM	DESCRIPTION	COMMENTS	PART NUMBER	
74	Upper Door Hinge Pin		30002727	Y
75	Complete Handle Assembly		30004175K	Y
75a	Handle Base Stub		30002714	Y
76	Wood Handle		1600664	Y
77	Handle Bolt	Pkg of 10	1201310-10	
78	Thermostat Handle Botl	Pkg of 10	1201243-10	
79	Ash Pan Assembly		30001690	
80	Flue Collar	Classic Black	30001576A	
		Biscuit	SRV30002947	
		Bordeaux	SRV30006701	
		Ebony	SRV30002910	
		Majolica Brown	SRV30004815	
		Twilight	SRV30007130	
81	Leg	Classic Black	30002835A	
		Biscuit	SRV30002877	
		Bordeaux	30006695A	
		Ebony	SRV30002897	
		Majolica Brown	30004843A	
		Twilight	30007124	
82	Jam Nut, Hex Head	Pkg of 10	1203290-10	
83	Bottom Heat Shield		30005037	
83a	Bottom Heat Shield, Right Wing		30005038	
83b	Bottom Heat Shield, Left Wing		30005039	
84	Grate Bottom		30005234A	
85	Thermostat Assembly		5005470	Y
86	Thermostat Cable		5005471	Y
87	Thermostat Friction Spring	Pkg of 10	1201846-10	
88	Primary Air Valve Assembly		30005275	
89	Heat Plate Vertical Flue		30005265	
90	Catalyst, Ceramic		30006623	
91	Thermostat Handle Assembly		30007067	
92	Primary Air Cover		30007069	
93	Primary Air Base		30007071	
94	Temperature Probe		30007274	
95	Braket, Temperature Probe		30007278	

Hearth & Home Technologies
LIMITED LIFETIME WARRANTY

Hearth & Home Technologies, on behalf of its hearth brands (“HHT”), extends the following warranty for HHT gas, wood, pellet and electric hearth appliances that are purchased from an HHT authorized dealer.

WARRANTY COVERAGE:

HHT warrants to the original owner of the HHT appliance at the site of installation, and to any transferee taking ownership of the appliance at the site of installation within two years following the date of original purchase, that the HHT appliance will be free from defects in materials and workmanship at the time of manufacture. After installation, if covered components manufactured by HHT are found to be defective in materials or workmanship during the applicable warranty period, HHT will, at its option, repair or replace the covered components. HHT, at its own discretion, may fully discharge all of its obligations under such warranties by replacing the product itself or refunding the verified purchase price of the product itself. The maximum amount recoverable under this warranty is limited to the purchase price of the product. This warranty is subject to conditions, exclusions and limitations as described below.

WARRANTY PERIOD:

Warranty coverage for consumers begins at the date of installation. In the case of new home construction, warranty coverage begins on the date of first occupancy of the dwelling or six months after the sale of the product by an independent, authorized HHT dealer/distributor, whichever occurs earlier. However, the warranty shall commence no later than 24 months following the date of product shipment from HHT, regardless of the installation or occupancy date. The warranty period for parts and labor for covered components is produced in the following table.

The term “Limited Lifetime” in the table below is defined as: 20 years from the beginning date of warranty coverage for gas appliances, and 10 years from the beginning date of warranty coverage for wood and pellet appliances. These time periods reflect the minimum expected useful lives of the designated components under normal operating conditions.

Warranty Period		HHT Manufactured Appliances and Venting					
Parts	Labor	Gas	Pellet	Wood	Electric	Venting	Components Covered
1 Year		X	X	X	X	x	All parts and material except as covered by Conditions, Exclusions, and Limitations listed
2 years			X	X			Igniters, auger motors, electronic components, and glass
		X	X	X			Factory-installed blowers
				X			Molded refractory panels
		X					Ignition Modules
3 years			X				Firepots, burnpots, mechanical feeders/auger assemblies
5 years	1 year	X					Vent Free burners, Vent Free ceramic fiber logs, Alumized Burners
			X	X			Castings and Baffles
6 years	3 years			X			Catalyst - limitations listed
7 years	3 years		X	X			Manifold tubes, HHT chimney and termination
10 years	1 year	X					Burners, logs and refractory
Limited Lifetime	3 years	X	X	X			Firebox and heat exchanger, Grate and Stainless Steel Burners, FlexBurn® System (engine, inner cover, access cover and fireback)
90 Days		X	X	X	X	X	All replacement parts beyond warranty period

WARRANTY CONDITIONS:

- This warranty only covers HHT appliances that are purchased through an HHT authorized dealer or distributor. A list of HHT authorized dealers is available on the HHT branded websites.
- This warranty is only valid while the HHT appliance remains at the site of original installation.
- This warranty is only valid in the country in which the HHT authorized dealer or distributor that sold the appliance resides.
- Contact your installing dealer for warranty service. If the installing dealer or distributor is unable to provide necessary parts, contact the nearest HHT authorized dealer or supplier. Additional service fees may apply if you are seeking warranty service from a dealer other than the dealer from whom you originally purchased the product.
- Check with your dealer in advance for any costs to you when arranging a warranty call. Travel and shipping charges for parts are not covered by this warranty.
- Limited Catalyst Warranty
 - o For wood burning products containing a catalyst, the catalyst will be warranted for a six-year period as follows: if the original catalyst or a replacement catalyst proves defective or ceases to maintain 70% of its particulate emission reduction activity (as measured by an approved testing procedure) within 36 months from the purchase date, the catalyst will be replaced for free.
 - o From 37 to 72 months a pro-rated credit will be allowed against a replacement catalyst and labor credit necessary to install the replacement catalyst. The proration rate is as follows:

Amount of Time Since Purchase	Credit Towards Replacement Cost
0 - 36 Months	100%
37 - 48 Months	30%
49 - 60 Months	20%
61 - 72 Months	10%

- o Any replacement catalyst will be warranted under the terms of the catalyst warranty for the remaining term of the original warranty. The purchaser must provide the name, address, and telephone number of the location where the product is installed, proof of original purchase date, date of failure, and any relevant information regarding the failure of the catalyst.

WARRANTY EXCLUSIONS:

This warranty does not cover the following:

- Changes in surface finishes as a result of normal use. As a heating appliance, some changes in color of interior and exterior surface finishes may occur. This is not a flaw and is not covered under warranty.
- Damage to printed, plated, or enameled surfaces caused by fingerprints, accidents, misuse, scratches, melted items, or other external sources and residues left on the plated surfaces from the use of abrasive cleaners or polishes.
- Repair or replacement of parts that are subject to normal wear and tear during the warranty period are not covered. These parts include: paint, wood and pellet gaskets, firebricks, grates, flame guides, batteries and the discoloration of glass.
- Minor expansion, contraction, or movement of certain parts causing noise. These conditions are normal and complaints related to this noise are not covered by this warranty.
- Damages resulting from: (1) failure to install, operate, or maintain the appliance in accordance with the installation instructions, operating instructions, and listing agent identification label furnished with the appliance; (2) failure to install the appliance in accordance with local building codes; (3) shipping or improper handling; (4) improper operation, abuse, misuse, continued operation with damaged, corroded or failed components, accident, or improperly/incorrectly performed repairs (5) environmental conditions, inadequate ventilation, negative pressure, or drafting caused by tightly sealed constructions, insufficient make-up air supply, or handling devices such as exhaust fans or forced air furnaces or other such causes; (6) use of fuels other than those specified in the operation instructions; (7) installation or use of components not supplied with the appliance or any other components not expressly authorized and approved by HHT; (8) modification of the appliance not expressly authorized and approved by HHT in writing; and/or (9) interruptions or fluctuations of electrical power supply to the appliance.
- Non-HHT venting components, hearth connections or other accessories used in conjunction with the appliance.
- Any part of a pre-existing fireplace system in which an insert or a decorative gas appliance is installed.
- HHT’s obligation under this warranty does not extend to the appliance’s capability to heat the desired space. Information is provided to assist the consumer and the dealer in selecting the proper appliance for the application. Consideration must be given to the appliance location and configuration, environmental conditions, insulation and air tightness of the structure.

This warranty is void if:

- The appliance has been over-fired, operated in atmospheres contaminated by chlorine, fluorine, or other damaging chemicals. Over-firing can be identified by, but not limited to, warped plates or tubes, deformation/warping of interior cast iron structure or components, rust colored cast iron, bubbling, cracking and discoloration of steel or enamel finishes.
- The appliance is subjected to prolonged periods of dampness or condensation.
- There is any damage to the appliance or other components due to water or weather damage which is the result of, but not limited to, improper chimney or venting installation.

LIMITATIONS OF LIABILITY

- The owner's exclusive remedy and HHT's sole obligation under this warranty, under any other warranty, express or implied, or in contract, tort or otherwise, shall be limited to replacement, repair, or refund, as specified above. In no event will HHT be liable for any incidental or consequential damages caused by defects in the appliance. Some states do not allow exclusions or limitation of incidental or consequential damages, so these limitations may not apply to you. This warranty gives you specific rights; you may also have other rights, which vary from state to state. EXCEPT TO THE EXTENT PROVIDED BY LAW, HHT MAKES NO EXPRESS WARRANTIES OTHER THAN THE WARRANTY SPECIFIED HEREIN. THE DURATION OF ANY IMPLIED WARRANTY IS LIMITED TO DURATION OF THE EXPRESSED WARRANTY SPECIFIED ABOVE.



352 Mountain House Road • Halifax, PA 17032
www.vermontcastings.com