

DEFIANT II

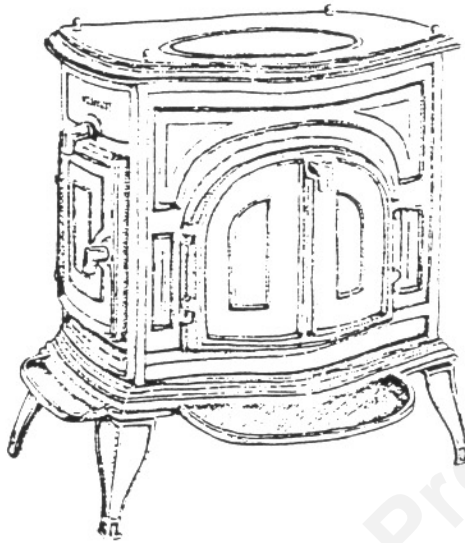

This section deals with Defiants manufactured between July, 1980 and January, 1985. This stove is easily distinguishable from current model Defiants as it does not offer a top-loading feature. The Defiant II is identical to the Defiant III with the exception of the following parts:

DEFIANT II PARTS LIST

<u>PART NAME</u>	<u>ITEM NUMBER</u>
Defiant II Front	130-3062 (part not available)
Rear Exit Top	130-3140 (part not available)
Top Exit Top	130-3132 (part not available)
Top Exit Insert	130-3200 (part not available)
Griddle	130-3154

<u>HARDWARE</u>	<u>SIZE</u>	<u>ITEM NUMBER</u>
Griddle Tabs	1/4 - 20	000-5838 (set of 2 tabs)

All aspects of repair and refurbishment of the Defiant II are the same as the Defiant III section of this manual, with the exception of griddle tabs that are used to secure the griddle to the top plate.

DEFIANT II

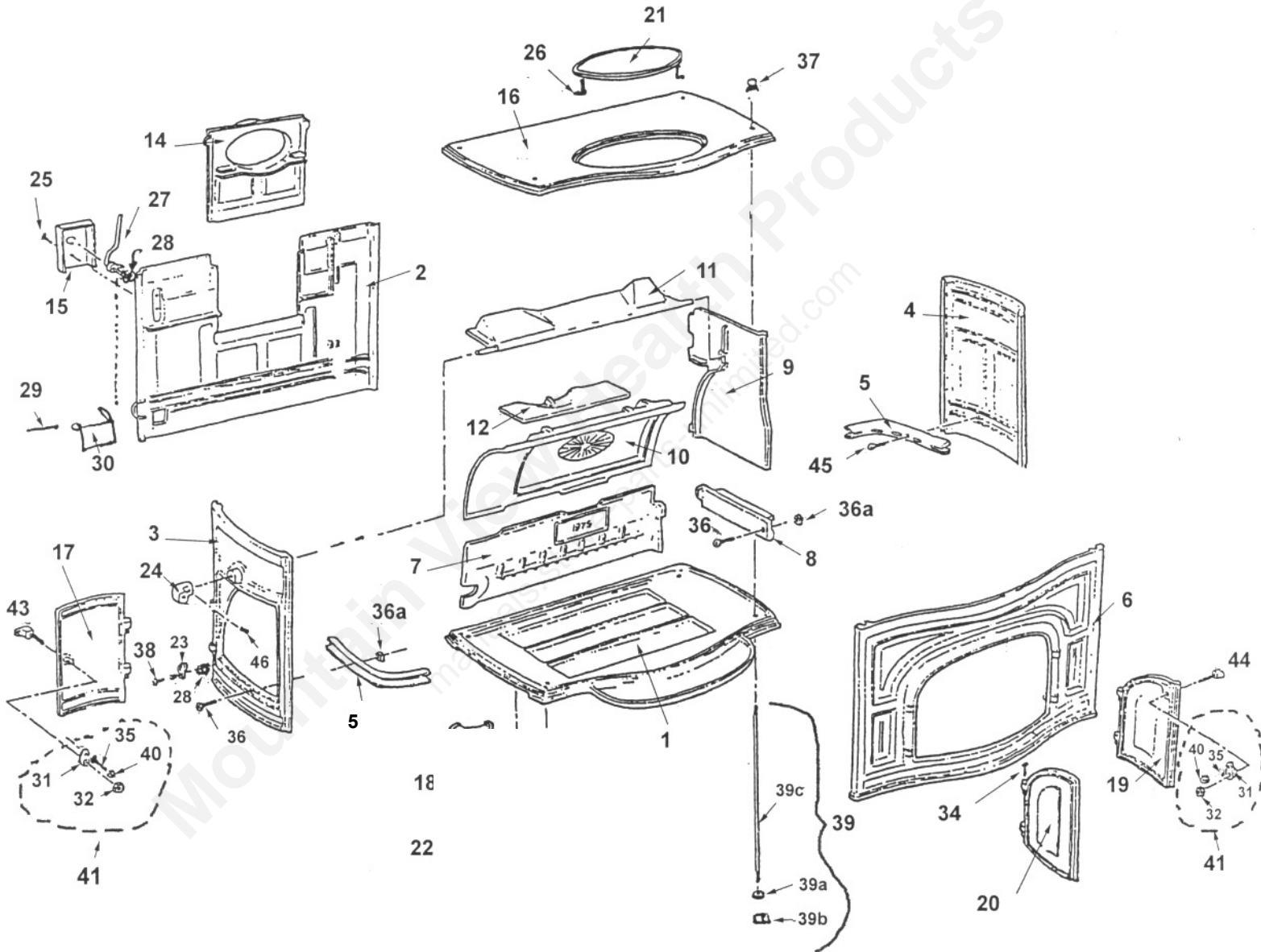

DEFIANT II

MODEL #: 0019 & 0028 DEFIANT II

FEATURES: Manufactured 6/80 through 12/84. Has oval griddle with no top loading, wrap around front & two piece, concave shaped fireback.

* denotes dead product - no substitute

ITEM #	PART #	DESCRIPTION	ITEM #	PART #	DESCRIPTION
1	130-3148	Bottom	26	000-5838	Set of Two Griddle Tabs (120-1857)
2	130-3070	Back	27	500-5467	Thermostat Assembly
3	500-0202*	Left End with Door		120-1960	Thermostat Ball Chain (per foot)
4	130-3116*	Right End	28	120-1846	Tension Spring for Thermostat
5	130-3162	AirTube	29	160-1555	Thermostat Flap Pin Only
6	500-0283*	Front with Doors	30	000-5800	Thermostat Flap w/ Eyelet
	130-3062*	Front only	31	120-0417	1/4-20 x 1/4" Socket Set Screw
7	130-3092	Lower Fireback	32	120-3290	3/8-16 Large Pawl Jam Nut
8	130-3100	Lower Baffle	33	120-1432	3/8-16 x 1" Hex Head Cap Screw
9	130-3108	Upper Baffle		000-5807	Leg Bolt Set w/ Washers & Hdle Holder
10	130-3078	Upper Fireback	34	160-0546	Door Pin
11	500-0323	Damper With Welded Pin	35	120-0436	Striker Bolt Only
12	130-3184	Smoke Shelf	36	120-0830	1/4-20 x 1 3/4" Phillips Flat Head
14	130-3192*	Rear Exit Insert	36a	120-3329	1/4-20 Plain Nut
	130-3203*	Top Exit Insert	37	160-0575	Finial Nut
15	130-3084*	Thermostat Cover	38	120-1007	10-24 x 3/4" Phillips Trs Head
16	130-3140*	Rear Exit Top	39	500-7497	Set of 4 Tie Rods, Washers & Bolts
	130-3132*	Top Exit Top	39a	120-2461	Star Washer (included in 500-7497)
17	130-3000	Side Load Door	39b	120-3226	1/4-20 Hex Head Nut (included in 500-7497)
18	130-3170	Side Ash Lip	39c	160-1617	Tie Rod Only (included in 500-7497)
19	130-3008	Right Door	40	120-0436	Striker Bolt Only
20	130-3016	Left Door	41	500-4024	Pawl Assembly (no jam nut)
21	130-3154	Griddle	42	120-0865	1/4-20 x 5/8" Phillips Flat Head
22	130-3225	Leg (one only)	43	500-4244	Side Door Handle Stub w/ Shaft
	500-0360	Legs (set of 4)	44	500-4237	Front Door Handle Stub w/ Shaft
23	130-0671	Secondary Air Control Cover	45	120-0889	1/4-20 x 1 1/2" Phillips Flat Head
24	500-4265	Damper Handle Stub w/ Set Screw	46	120-0563	5/16-18 x 5/16 Socket Set Screw
25	120-1010	10-24 x 1 1/2" Truss Head Phillips	47	120-2488	Washer for Leg Bolts

ITEMS NOT SHOWN

000-4342	Fallaway Handle Complete
160-0620	Ceramic Handle Only
120-1294	Handle Screw
160-0650	Handle Stub
120-1832	Handle Stub Roll Pin

ACCESSORIES

000-0124	Defiant Screen
000-0868	Set of 4 Short (3") Legs

REPAIR KITS

000-5837 DEFIANT II & III FIREBACK AND BAFFLE KIT

- 000-5833 Box 1 - includes: upper fireback and lower fireback
- 000-5836 Box 2 - includes: upper baffle, lower baffle, lower baffle nut & bolt, instructions.

GASKETS

120-3588	5/16" Medium Density 6ND Gasket	4.5'	Upper Fireback
		7'	Front Doors
		4'	Side Doors
120-3668	5/16" Gasket Wire Fiberglass with Core	4'	Top for Griddle

DEFIANT II DRILL & TAP GUIDE

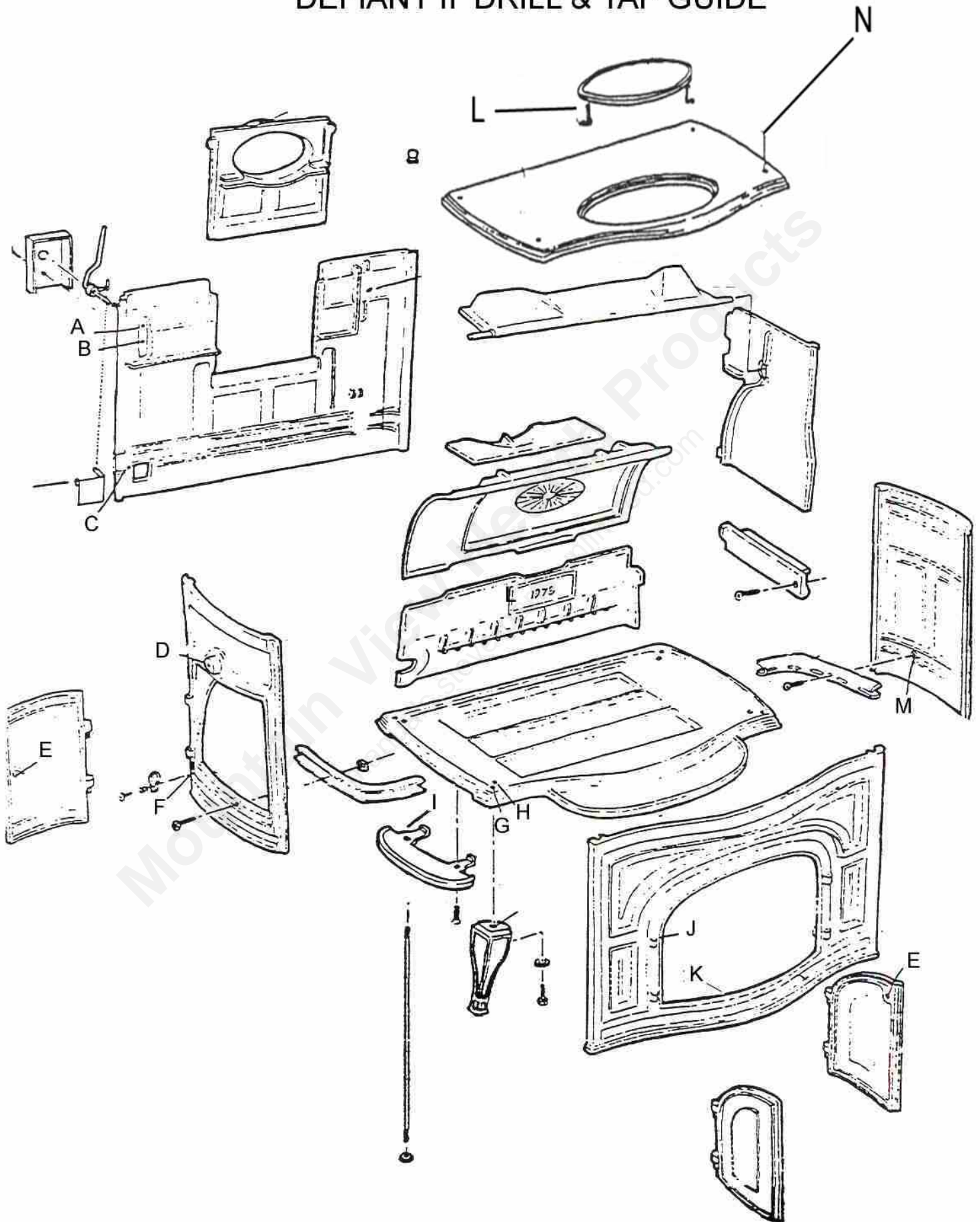

DEFIANT II DRILL AND TAP KEY

DIAGRAM #	TO ACCOMMODATE THIS HOLE	DRILL SIZE	TAP SIZE
A	Thermostat hole	#22	10-24
B	Thermostat cover screw hole	#22	10-24
C	Draft damper wire holes	1/8" x 3/22" deep	N/A
D	Damper pin hole	#W (.3860")	N/A
E	Door handle hole	3/8"	N/A
F	Secondary air cover screw hole	#22	10-24
G	Leg bolt holes	5/16"	3/8-16
H	Bottom tie rod holes	5/16"	N/A
I	Ashlip screw holes	13/64"	1/4-20
J	Door pin holes	3/16"	N/A
K	Andiron holes	#3 (.2130") x 5/8" deep	1/4-20
L	Griddle Weld Tab	13/64"	1/4-20
M	Secondary air tube hole	#22	10-24
N	Top tie rod hole	5/16"	N/A

Mountain View Hearth Products
manuals.stove-parts-unlimited.com

One of the major objectives in the Defiant design was ease of cleaning. The interior castings and Damper assembly are easily accessible for cleaning or replacement because they can be removed independently from the exterior castings. The first section of this manual explains this procedure. All instructions given are looking at the front of the stove.

If the need arises for replacement of an exterior casting, the manual continues with instructions for the complete teardown and reassembly of the stove.

We recommend that you reassemble the stove without cement first to make sure all the parts fit. New parts may have to be ground slightly; if so, be sure to wear protective eye glasses and a particle mask. If you are disassembling and rebuilding your Defiant alone, you may find that tying a rope around the stove will hold the cast plates in place. The exterior cast iron stove parts are quite heavy, so having an assistant may also be helpful.

Replacement of the interior baffles: Upper and Lower Firebacks, and Upper and Lower Baffles can be accomplished by one person.

Be sure to set aside a good block of time to reassemble the stove with cement. The furnace cement can lose its pliability if exposed to the air for a long period of time.

If you have any questions, please feel free to contact the Warranty Department at (802)728-3181.

TOOLS NEEDED:

For disassembly of interior castings only:

- Trouble Light
- Large Screwdriver
- #2 Phillips Screwdriver
- Gloves
- Chisel
- Wire Brush
- Putty Knife
- Particle Mask
- Old Clothes
- Penetrating Oil
- Drop Cloth
- 5/32" Allen Wrench for Damper Handle
- *Dead Blow Hammer or Hammer and Block of Wood

For complete disassembly, also have available:

- Protective Eyewear
- Vice Grips
- Caulking Gun
- Grinder or File
- 10 ft. 1/2" Rope
- Industrial or Old Vacuum Cleaner
- Block of Wood or Cement to Support Stove off Floor
- 1/8" Allen Wrench for Loading Door Handle
- 9/16" Socket or Open End Wrench

*Cast iron should never be struck directly with a metal hammer.

MATERIALS PROVIDED:

For disassembly of interior castings only:

- Cast Replacement Plates
- (1) 1/4-20x1 3/4" Flathead Machine Screw and Nut for Lower Baffle
- (1) 1/4-20x1 3/4" Flathead Machine Screw and Nut for Primary Air Tube
- (1) 1/4-20x1 1/2" Flathead Self-Tapping Machine Screw for Secondary Air Tube
- 1 can Paint

For complete disassembly, also provided:

- 2 cans Paint
- 4 Defiant Tie Rods
- 3 11-oz. Caulking Tubes Furnace Cement

CONTENTS

I.	DISASSEMBLY OF INTERIOR CASTINGS	Pg. 5
II.	REASSEMBLY OF INTERIOR CASTINGS	Pg. 7
III.	COMPLETE DISASSEMBLY OF DEFIANT	Pg. 9
IV.	ASSEMBLY OF DEFIANT	Pg.10

I. DISASSEMBLING THE DEFIANT INTERIOR CASTINGS

STEP 1 REMOVE THE LOWER BAFFLE

With a large Phillips Head Screwdriver, remove the screw in the lower baffle. This screw fastens into a nut which, in turn, rests in a slot behind the baffle, so no pliers or wrench are required. If the head is bad, drill it out with a 1/4" drill. The head will fall off and the other half is easily removed after taking out the Lower Baffle.

Reach in through the front doors, pull the forward end of the Lower Baffle towards the Loading Door End, and remove it.

As the Lower Baffle comes away, the Upper Baffle should slide straight down into position for removal.

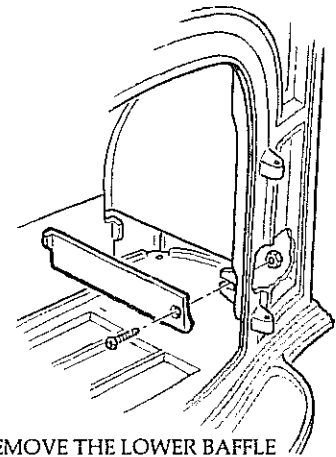

FIG. 1 REMOVE THE LOWER BAFFLE

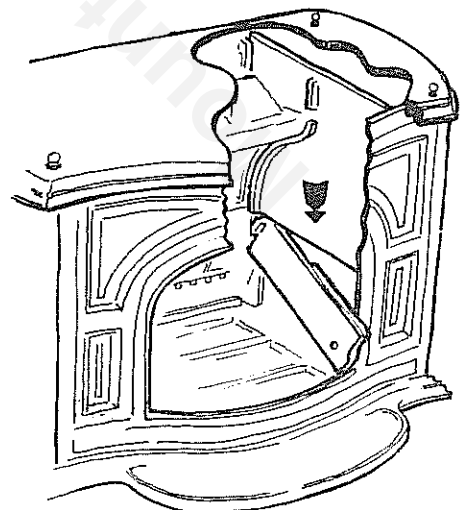

FIG. 2 SLIDE UPPER BAFFLE DOWNWARD

STEP 2 REMOVE THE UPPER BAFFLE

By slightly lowering and swinging the back edge towards the Right End, you can disengage the Upper Baffle from the Upper Fireback, and rest it on the Secondary Air Tube for a moment. This move will also disengage the Damper Pin on the right end of the Damper from its slot in the Baffle.

Maneuver the Upper Baffle down and around the Damper Pin to remove it from the stove.

If the Baffle seems to bind on one of the tabs on the Back Plate, you may have to follow a slightly different procedure. This procedure requires the removal of the Upper Fireback to release the Upper Baffle. Pry upward and outward with a large screwdriver inserted midpoint along the junction of the Lower and Upper Firebacks.

The Upper Fireback should slip forward over the tabs on the Lower Fireback. Remove the Upper Baffle by tapping it with a hammer and a block of wood toward the right end.

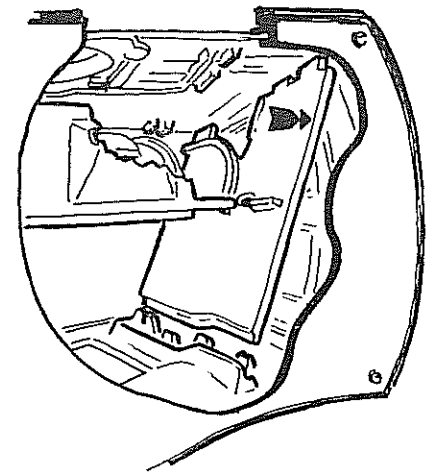

FIG. 3 SWING UPPER BAFFLE TOWARD RIGHT END - VIEW FROM TOP OF STOVE

STEP 3 REMOVE THE DAMPER

With the large (1/8") Allen Wrench that came with your stove, loosen the set screw on the Damper Handle and pull it off the Handle Pin. Reach through the Griddle and slide the Damper towards the Right End to disengage the Handle Pin from the Loading Door End. Bring the whole Damper forward and down into the fire-box, and take it out through the Loading Door or Front Door.

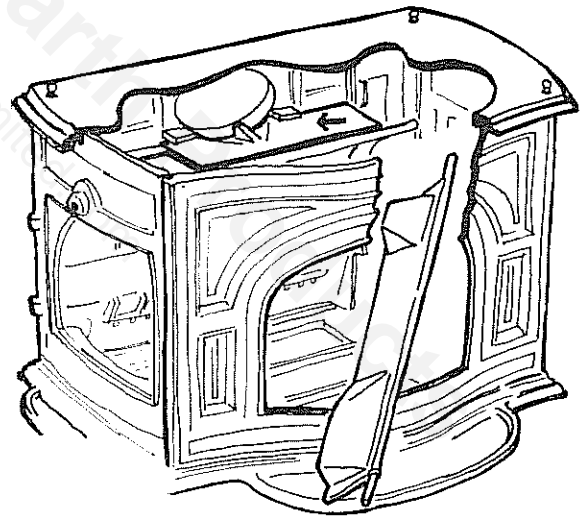

FIG. 4 REMOVE THE DAMPER

STEP 4 REMOVE THE SMOKESHELF

Reach in through the Flue Collar and lift the front of the Smokesheff upwards and slide forward to disengage it from the tabs on the Back Plate. Be careful not to drop the Smokesheff down into the smoke passages below.

Get your fingers underneath the Smokesheff, move it towards the Loading Door End, and rotate the other end out the Flue Collar, or out through the Front Loading Door.

STEP 5 REMOVE THE UPPER FIREBACK

Reach in through the Front Doors and hold the Upper Fireback along its top edge. Slide it towards the Right End with a lifting motion to disengage it from the Loading Door End. Let it fall forward slightly, lift it off the Lower Fireback, and remove.

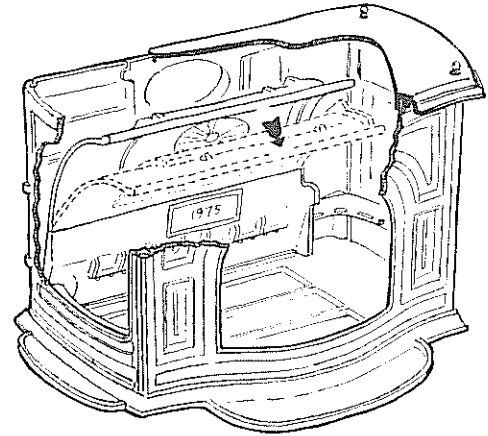

FIG. 5 REMOVE THE UPPER FIREBACK

STEP 6 REMOVE THE PRIMARY AND SECONDARY AIR TUBES

Unscrew the Primary Air Tube screw with a Phillips Head Screwdriver and remove. You may need to use penetrating oil on the nut. Remove the Secondary Air Tube by unscrewing the Phillips Head Screw. It may be necessary to loosen the screw by tapping the screwdriver with a few sharp blows.

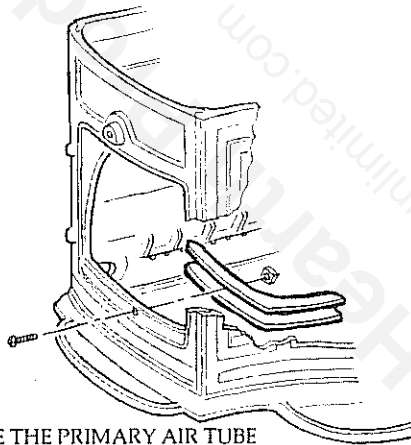

FIG. 6 REMOVE THE PRIMARY AIR TUBE

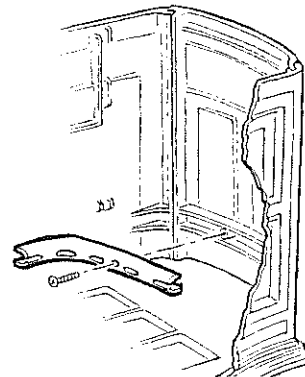

FIG. 7 REMOVE THE SECONDARY AIR TUBE

STEP 7 REMOVE THE LOWER FIREBACK

Reaching in through the Front Doors of your stove, hold the top edge of the Lower Fireback and slide it toward the Right End to disengage it from the Loading Door End. Tip it forward and remove it. Because this piece is cemented, it may require a prying effort to move it away from the Stove Back.

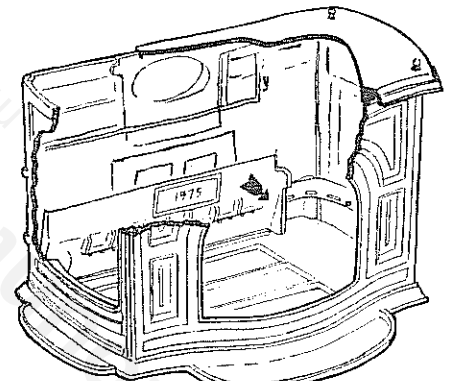

FIG. 8 REMOVE THE LOWER FIREBACK

THIS COMPLETES THE DISASSEMBLY OF THE INTERIOR BAFFLE PLATES IN YOUR DEFIANT

STEP 8 CLEAN STOVE AND STOVE PARTS

Vacuum the grooves that the Lower Fireback fits in. Clean the Secondary Air Tube channels on the Back Plate and on the back of the Lower Fireback of all dried furnace cement and soot. Wipe with a damp cloth so that the replacement furnace cement will stay in place when applied.

Clear the Primary and Secondary Air Tube passages on the Right and Left Ends of all ash and soot before replacing the cast iron parts.

Clean dried cement from the Smoke Deflector Ridge on the inside of the Left End.

II. ASSEMBLING THE DEFIANT INTERIOR CASTINGS

STEP 1 REPLACE THE SECONDARY AIR TUBE

Fit the edges of the Secondary Air Tube in channels on the Right End Plate. One Phillips Head Screw ($1/4$ -20x $1\frac{1}{2}$ " Flathead Machine Screw - Self-tapping) is provided with the materials for the replacement of the Secondary Air Tube on the Right End (see FIG. 7).

STEP 2 REPLACE THE LOWER FIREBACK

Cement the Secondary Air Tube Channels along the Back Plate. Cement the channel between the tabs and ridge on the opening in the Load Door End. (See FIG. 10)

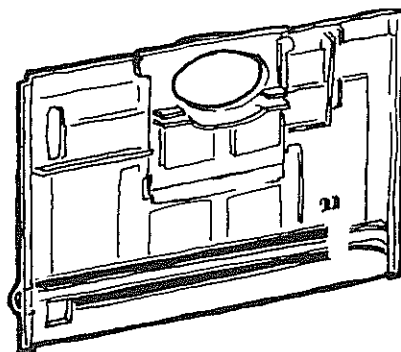

FIG. 9 CEMENT SECONDARY AIR TUBE CHANNELS ON THE BACK PLATE

Kneel facing the front of the stove. Place the lower edge of the Lower Fireback between the Back Plate and the rib on the Bottom Plate.

Pivot the top of the Lower Fireback towards the Back Plate and slide it (tap gently with hammer and block of wood) left to engage the tabs at the Loading Door End. The right end of the Lower Fireback fits over the Secondary Air Tube.

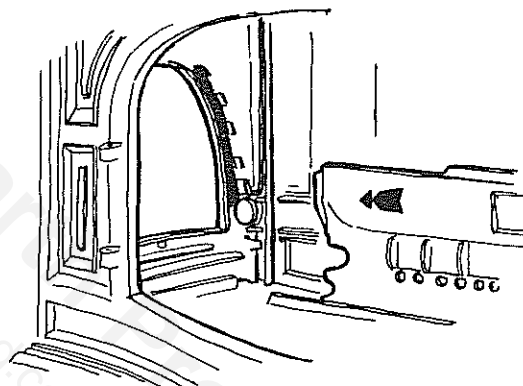

FIG. 10 ENGAGE LOWER FIREBACK WITH TABS IN THE LEFT END

STEP 3 REPLACE THE PRIMARY AIR TUBE

Fit the lower edge of the Primary Air Tube between the tabs provided on the Loading Door End. The Phillips Head Screw is started on the outside of the Loading Door End; the nut goes in the recessed square on the tube (see FIG. 6).

STEP 4 REPLACE THE UPPER FIREBACK

Place the Upper Fireback on the Lower Fireback so that the tabs on the bottom of the Upper Fireback fit between the tabs on the upper edge of the Lower Fireback (see FIG. 5). Pivot the upper edge of the Upper Fireback backwards and slide it left to engage the tabs at the Loading Door End. You may have to tap it into place using a hammer and block of wood.

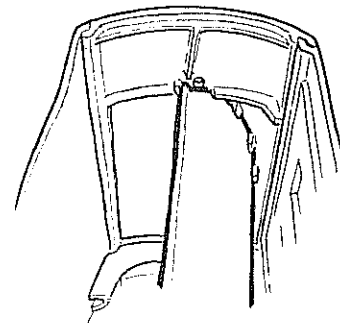

FIG. 11 ENGAGE UPPER FIREBACK WITH TABS IN THE LEFT END

STEP 5 REPLACE THE DAMPER

Set the Damper on top of the Upper Fireback so that the Handle Pin protrudes through the hole in the Loading Door End. There is a rib at the Loading Door End of the back plate upon which the Damper rests in its lowered position. Make sure the Damper is not caught under this rib.

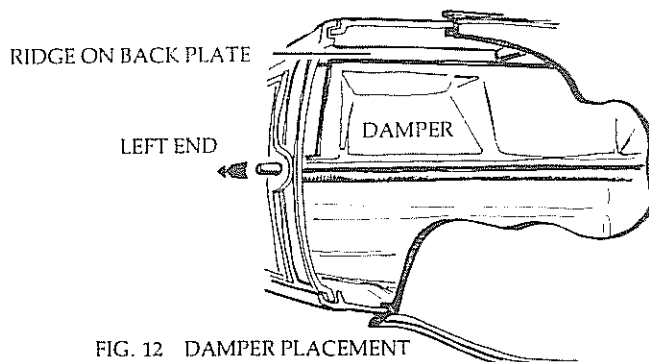

FIG. 12 DAMPER PLACEMENT

STEP 6 REPLACE THE UPPER BAFFLE

Rest the lower edge of the Upper Baffle on the Secondary Air Tube in the back corner of the stove while you locate the front edge of the Upper Baffle between the tabs on the inside of the Front Plate.

Now rotate the back edge toward the Fireback and at the same time lift up to hook the Baffle over the end of the Damper Shaft. This maneuver might be more easily accomplished if you stand at the Right End, reach your left hand through the griddle to lift the Baffle, and your right hand through the Flue Collar opening to guide the Damper Shaft. Check to make sure the front edge of the Upper Baffle remains between the tabs as you are rotating and lifting. The rear edge of the Upper Baffle makes a clean corner with the Fireback when in proper position.

STEP 7 REPLACE THE LOWER BAFFLE

Grab the Upper Baffle and raise it straight up so that you can hook the tab of the Lower Baffle into the Fireback. Be careful when lifting not to displace the Upper Baffle towards the Right End; it will slip out if you do. You can carefully rest the weight of the Upper Baffle on this little tab, remove your hand, and rotate the forward edge of the Lower Baffle into place. Install the Phillips Head Screw and Nut in the Lower Baffle.

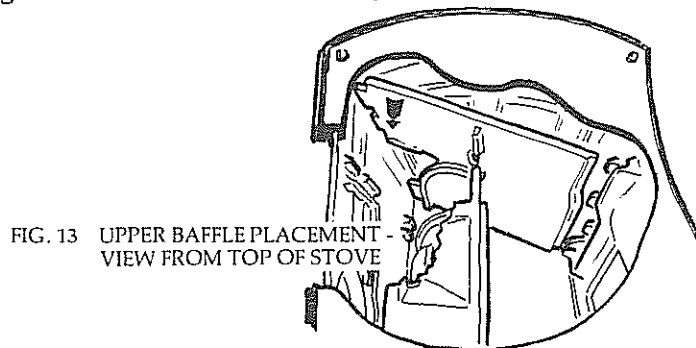

FIG. 13 UPPER BAFFLE PLACEMENT - VIEW FROM TOP OF STOVE

STEP 8 REPLACE THE SMOKESHELF

Holding the SmokesheLF so the triangular fin is upward and pointing toward the Back Plate of the stove, lift it through the front of the stove to rest on the Upper Fireback and tabs on the Back Plate.

STEP 9 FINISHING

Replace the Damper Handle.

Replace the Legs.

Reline the stove with a 1½" layer of ash to insulate it against excess heat.

Repaint the stove.

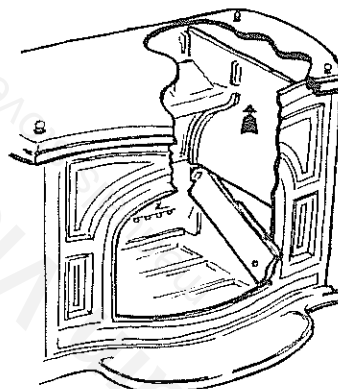

FIG. 14 RAISE UPPER BAFFLE TO POSITION LOWER

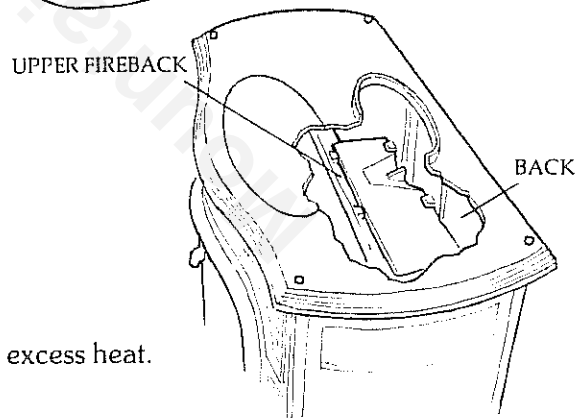

FIG. 15 SMOKESHELF PLACEMENT

YOU HAVE NOW COMPLETED THE REASSEMBLY OF THE INTERIOR CASTINGS.

REMEMBER: YOU WILL HAVE TO BUILD EIGHT TO TEN SMALL BREAK-IN FIRES AS DESCRIBED IN THE OPERATION MANUAL TO TEMPER ANY NEW CASTINGS IN YOUR DEFIANT.

III. DISASSEMBLING THE DEFIANT

To replace exterior castings or to completely reseal your stove seams, you will want to remove all cast iron plates. If you're working without an assistant, tie your rope loosely around the body of the stove to prevent castings from falling as you remove them.

STEP 1 PREPARATION

With assistants, lift the Defiant off the floor onto blocks of wood or cement high enough to remove the legs.

Remove the legs with a 9/16" socket wrench.

STEP 2 FOLLOW STEPS 1-7 IN SECTION I TO REMOVE ALL THE INTERIOR CASTINGS IN THE STOVE.

STEP 8 REMOVE TOP

Break the finial nuts off the Tie Rods by wrenching them back and forth with vice grips. Pull the Tie Rods down through the Bottom Plate: you will have to bend them to remove them completely. Don't worry, these rods and nuts will be replaced with the new materials provided.

With the rubber mallet, hammer upward under the outer edges of the Top Plate to loosen the seal. Lift off the Top Plate and set aside for cleaning.

STEP 9 REMOVE EXTERIOR CASTINGS

Loosen the cemented seams by tapping outward along the upper edges of the four side plates.

When the cement seal is broken, lift out the exterior castings in this order: Front, Left End, Right End, Back.

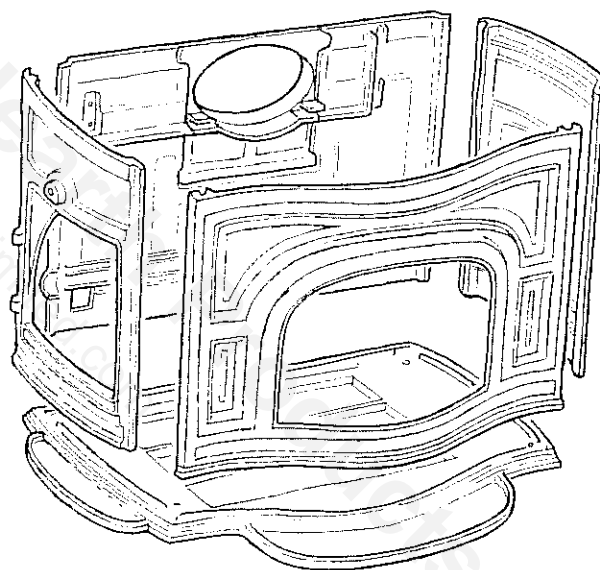

FIG. 16 LOOSEN AND REMOVE EXTERIOR CASTINGS

STEP 10 CLEANING

The cement channels in each cast iron plate will have to be cleaned of furnace cement and soot. A hammer and narrow chisel or screwdriver usually performs this operation very easily. Also, concentrate on any edges that will fit back into a cemented channel as you will find excess dried cement there as well.

IV. ASSEMBLING THE DEFIANT

We recommend assembling the stove without cement ("Dry assembly") once to familiarize yourself with the procedure and to determine if any of the new castings need to be ground or filed. All italicized instructions refer to cementing steps pertaining to the permanent assembly, so follow the non-italicized instructions for the dry assembly.

STEP 1 ASSEMBLE THE EXTERIOR CASTINGS

Place the Bottom Plate on blocks high enough to be able to replace the legs later.

Tape over the leg bolt holes with masking tape so they won't fill with furnace cement during the next step.

Cement the four channels in the Bottom Plate.

Cement the side channels in the Front, Back, Left and Right Plates.

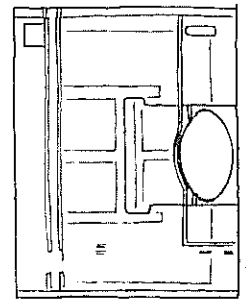
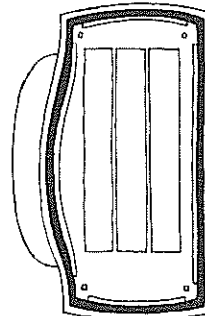
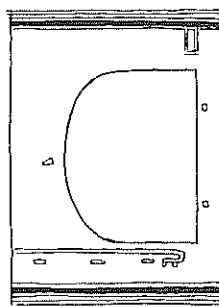
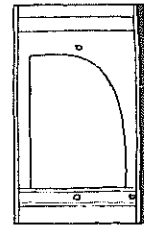
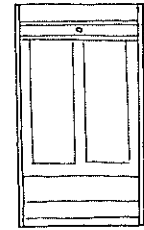

FIG. 17 CEMENT EXTERIOR PLATES

Replace the outer castings in the following order: Back Plate, Right End overlapping the edge of the Back Plate, Left End overlapping the edge of the Back Plate, and Front Plate overlapping the edges of the Right and Left Ends.



Hammer along all the edges and particularly upper corners of the outside castings to set them securely in place.

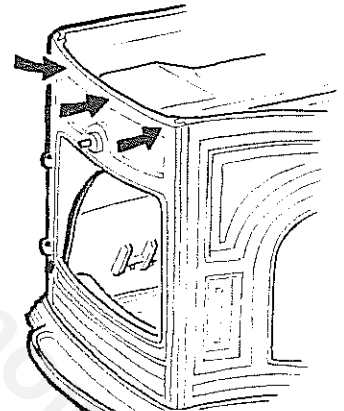

FIG. 18 HAMMER UPPER EDGES OF CASTINGS TO SEAT SECURELY

Cement the channel in the Top Plate.

Replace the Top Plate over the four outside castings.

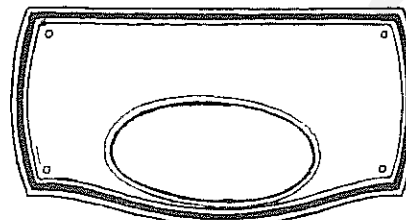

FIG. 19 CEMENT CHANNELS IN TOP PLATE

Hammer all the way around the perimeter of the Top Plate to seat it down over the outer castings. You may have to hammer the upper corners of the side plates inward to get the top to settle down correctly.

STEP 2 INSTALL THE TIE RODS

Screw the Finial Nuts on the four Tie Rods (on the end with a shorter length of threads).

Guide the Rod down from the Top Plate through the Bottom Plate.

Install the other three Tie Rods the same way.

Using cardboard to protect the Finial Nuts, hold them with vice grips or pliers and screw the Hex Nuts onto the bottom of the Tie Rods.

Tighten the Hex Nuts on the Tie Rods, hammer the outside corners of the Top and Side Plates to insure that they are in place. Tighten the Tie Rod nuts again.

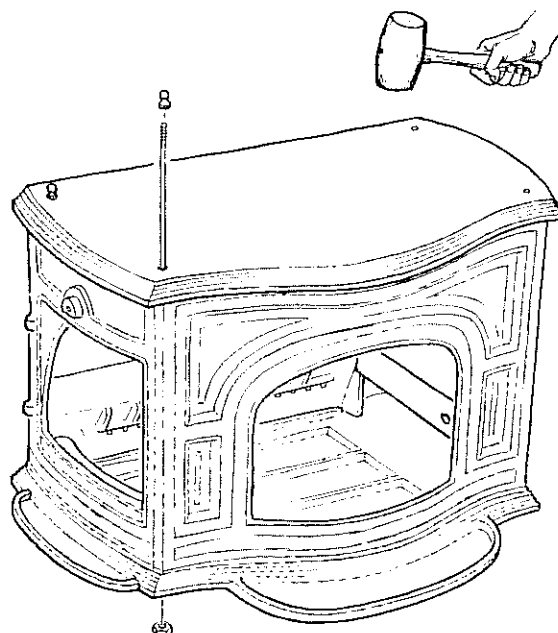

FIG. 20 REPLACE TOP AND ATTACH TIE RODS

Break off the excess Tie Rod at the bottom, just below the hex nuts, by wrenching back and forth with the vice grips. Otherwise, the rod prevents the legs from being attached.

Replace the legs using the 9/16" socket to tighten the leg bolts until snug.

STEP 3 FINISHING THE EXTERIOR CASTINGS

Smooth furnace cement in the outside seams of the stove with your finger or a putty knife.

Remove all excess cement from the outside of the stove with warm water and a sponge.

Repaint the stove with the paint provided.

Reattach hardware: Load Door Handle, Secondary Air Tube Cover, Thermostat Assembly.

NOW RETURN TO SECTION II, STEP 1 FOR THE ASSEMBLY OF THE INTERIOR CASTINGS.