



Dutchwest Convection 90 - 94 Service Procedure

Damper Rod Replacement

For 8 months prior to February of 1994, the '93 series was made with a threaded rod installed in a threaded hole in the inner top as per earlier models made from 1990 - 1993. In February of 1994, the thread system that had a tendency to jam was updated to the current system with no threads. These instructions show you how to replace the old damper with the new system.

Models: Small 2460 & 2181; Large 2461 & 2183; Extra-Large 2462 & 2184; Sequoia 2160

Please read these instructions carefully before beginning the installation.

PARTS NEEDED:

- Damper Rod; (Small – 7001154, Large & Sequoia - 7001131, or Extra-Large – 7001160)
- 5/8" i.d. washer (1202561)
- 5/8" retaining ring (1203058)

TOOLS:

- 7/16" socket or open-end wrench
- Needle nose pliers
- 1/8" Allen wrench

Fig. 3 Remove the top

PROCEDURE: (shown for convection stoves – Sequoia is similar)

1. Evenly loosen and then remove all four bolts that secure the top plate to the sides of the stove (**Fig. 3**).
2. Remove the top plate. Carefully remove the refractory package from within the inner top. Leave the catalytic element in place, but take care not to damage it (**Fig.4**).
3. Remove both the nut and bolt (**a**) that secure the damper adjuster to the damper using a 7/16" socket or open-end wrench. The nut must be reached from inside the stove. Also, remove the two damper tab bolts and damper tabs (**b**), **Fig 5**. Remove the damper.

Loosen all four bolts before removal.

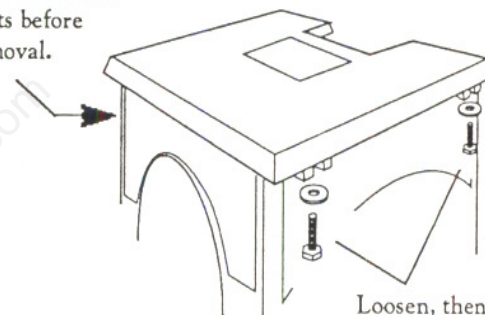

Fig. 3 Remove the Top

Loosen, then remove these bolts.

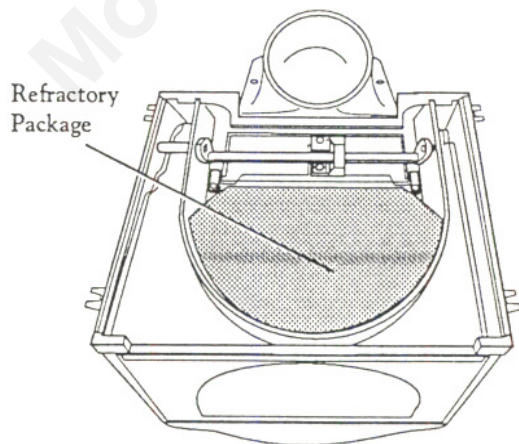

Fig. 4 Remove Refractory

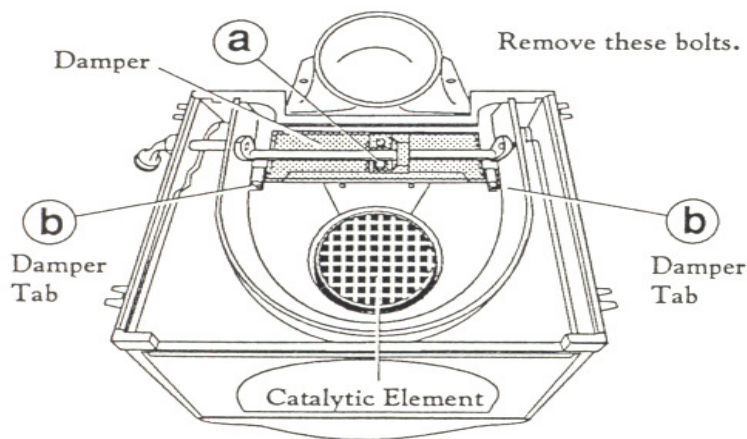

Fig. 5 Remove Damper

4. Rotate the damper crank forward and flip the adjuster plate upside-down, (you will see #950 cast into the plate) (**Fig. 6**). Slide the adjuster plate over to the left end of the crank.

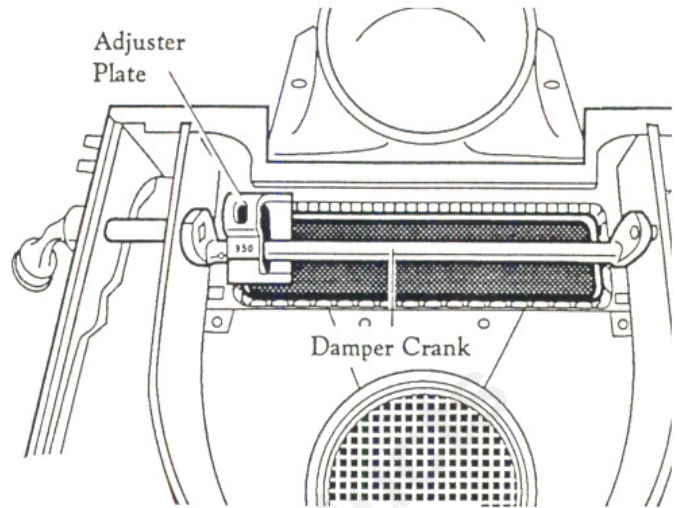

Fig. 6

5. Disconnect the old damper rod from the crank by rotating both the crank and the adjuster as a unit in a counter-clockwise direction (facing the left end of the stove). As you rotate the crank and adjuster plate through the high point of the arc, you will need to maneuver the adjuster plate somewhat to clear the back plate of the stove (**Fig. 7**). Unscrew the damper rod from the stove.

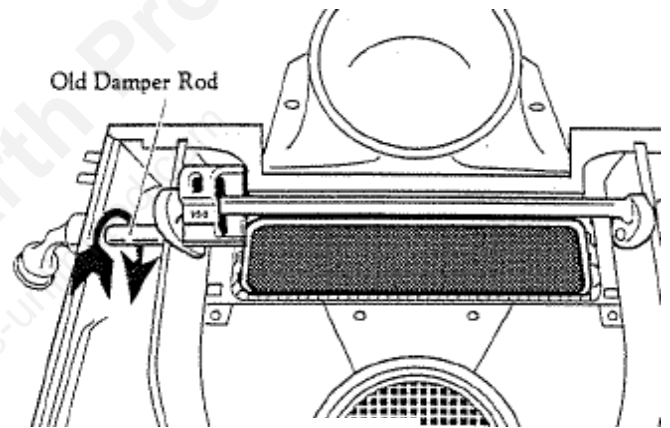

Fig. 7

6. Loosen the set screw with the Allen wrench to remove the faucet handle from the old rod and re-install the handle on the new damper operating rod.
7. Install the new operating rod. Place the 5/8" washer onto the rod between the outer and inner walls (**Fig. 8**), then insert the end of the rod into the crank. Properly oriented, both the handle and the crank should be pointing downward.

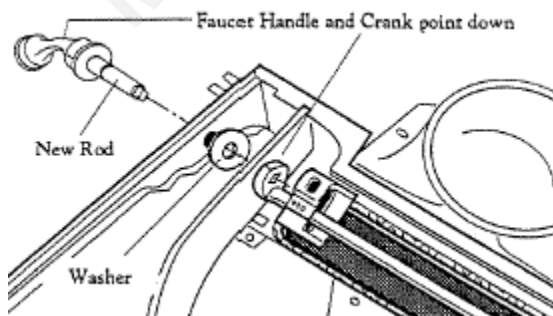

Figure 8

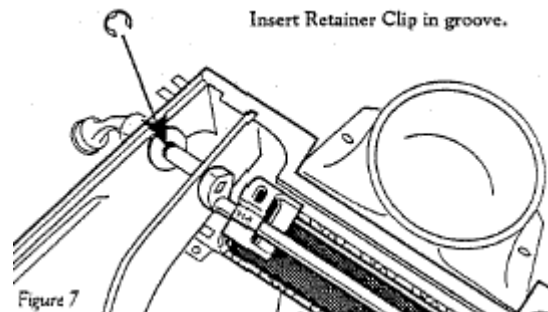

Figure 9

8. Push the washer against the stove wall and use needle nose pliers to insert the retaining clip onto the groove in the rod to lock the rod in place (**Fig. 9** previous page).

NOTE: This is a good time to check the condition of the damper gasket and replace it, if necessary.

9. Re-position the damper adjuster plate right side up and secure it to the damper using the 7/16" bolt and nut.
10. Check the damper rod/damper plate action to be sure that the damper seals tightly in the closed position. Rotate the adjustment bolt (**a in Fig. 10**), clockwise to improve the seal against the gasket.

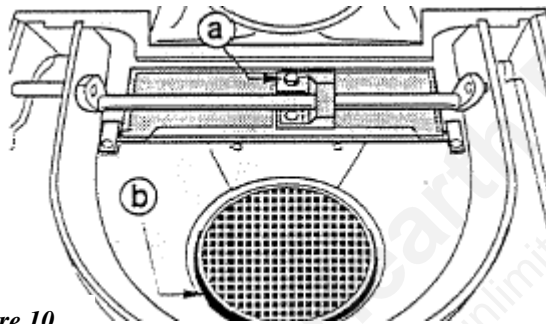

Figure 10

11. Inspect the catalytic element and carefully clean any debris from it using a vacuum. Be sure the interam gasket (**b in Fig 10**) is properly positioned around the element. Replace the refractory package.
12. Replace the top plate and secure it with the bolts and washers used previously. Gradually tighten the bolts evenly, alternating from side to side.