

ENCORE™

Owner's Guide

Model 2550

For use in North America

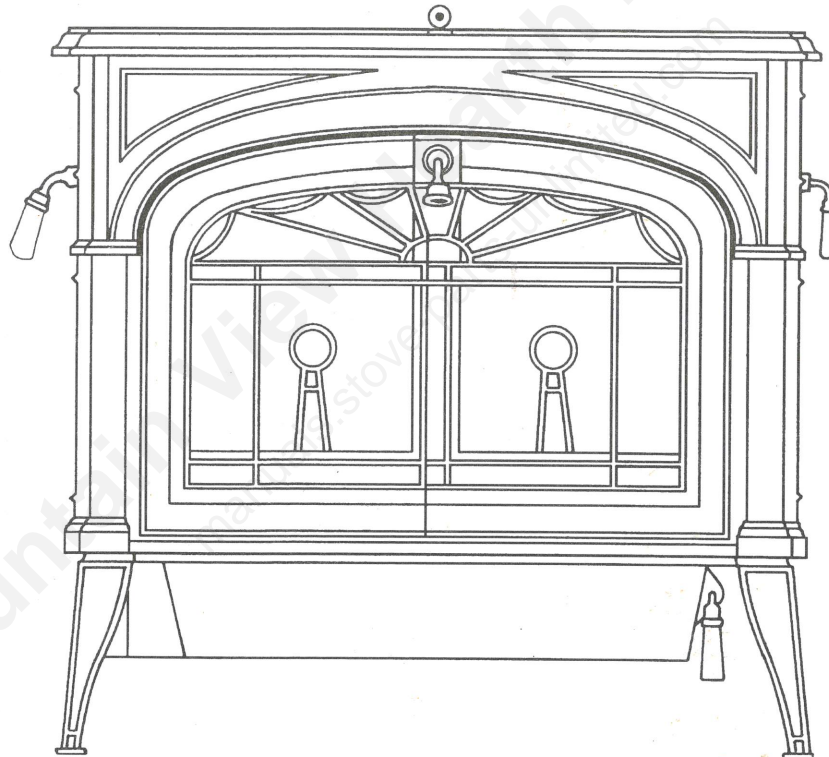

SAFETY NOTICE: IF YOUR ENCORE IS NOT PROPERLY INSTALLED, OPERATED AND MAINTAINED, A HOUSE FIRE MAY RESULT. FOR SAFETY, FOLLOW ALL INSTALLATION, OPERATION AND MAINTENANCE DIRECTIONS. CONTACT LOCAL BUILDING OFFICIALS ABOUT RESTRICTIONS AND INSTALLATION INSPECTION REQUIREMENTS IN YOUR AREA.

VERMONT CASTINGS, INC.

Welcome

Congratulations on your choice of a Vermont Castings Encore. With this purchase you have made a commitment to make the hearth a place of warmth, beauty, and comfort in your home. At Vermont Castings, we share that joy and appreciation for the hearth. You may be assured that your cast-iron Vermont Castings stove has been made with the utmost care and will provide you with many years of service.

As you become acquainted with your new stove or fireplace, you will find that its visual appearance is matched by its functionality, due to cast iron's unique capability to absorb and radiate heat.

Also, Vermont Castings products are among the cleanest-burning wood stoves and fireplaces available today. As an owner of a Vermont Castings stove, you make a strong statement for pollution-free energy. Clean burning, however, depends on both the manufacturer and the operator. Please read this manual carefully to understand how to properly operate and maintain your stove or fireplace.

At Vermont Castings, we are equally committed to your satisfaction as a customer. That is why we maintain an exclusive network of the finest dealers in the industry. Our dealers are chosen for their expertise and dedication to customer service. They are factory-trained and knowledgeable about every Vermont Castings product. Feel free to contact your Authorized Vermont Castings Dealer anytime you have a particular question about your stove or its performance.

This manual contains valuable instructions on the installation and operation of your Vermont Castings stove. It also contains useful information on maintenance and assembly of this product. We urge you to read the manual thoroughly and to keep it as a reference.

Sincerely,

All of us at Vermont Castings

Your Vermont Castings dealer can supply accessories to enhance the versatility, appearance, and safety of your stove. These are:

Warming Shelves,	#1560-1566
a Sparkscreen,	#0127
Bottom Heat Shield,	# 0164
an Outside Air Adapter,	#3257
a Mobile Home Kit,	#3251
matching porcelain stove pipe, and heat shields for the pipe	#0191

Table of Contents

Installation	1
Clearance Charts	11
Assembly	15
Operation	16
Maintenance	24
Appendix: Catalytic Combustor	30
Warranty	31
Parts Diagram and list	32, 33
Specifications	Back Cover

This manual describes the installation, operation, and maintenance of the Vermont Castings Encore Model 2550 catalytic-equipped wood burning heater. This heater meets the U.S. Environmental Protection Agency's emission limits for wood heaters sold on or after July 1, 1990. Under specific test conditions this heater has been shown to deliver heat at rates ranging from 8,700 to 41,700 Btu/hr.

The Encore Model #2550 has been tested and is listed by Warnock Hersey International of Middleton, Wisconsin. The test standards are ANSI/UL-1482 and ANSI/UL-737 for the United States, and ULC S627 and CAN/CSA-B366.2 for Canada. The Encore is listed for burning wood. Do not burn other fuels. The Encore is listed and approved for use in mobile homes in the United States only when installed with Vermont Castings Mobile Home Kit #3251.

We recommend that you hire a professional installer certified by the Wood Heat Education and Research Foundation (WHERF) or the Wood Energy Technical Training (WETT) to install your stove, or to advise you on the installation should you attempt to install it yourself.

Please read this entire manual before you install and use your new stove. Failure to follow instructions may result in property damage, bodily injury, or even death.

SAVE THESE INSTRUCTIONS.

Installation

Stove Installations Must Be Safe and Legal

SAFETY NOTICE: IF YOUR ENCORE IS NOT PROPERLY INSTALLED, A HOUSE FIRE MAY RESULT. TO REDUCE THE RISK OF FIRE, FOLLOW THE INSTALLATION INSTRUCTIONS. CONTACT LOCAL BUILDING OR FIRE OFFICIALS ABOUT RESTRICTIONS AND INSTALLATION INSPECTION REQUIREMENTS IN YOUR AREA.

Before you begin an installation, be sure that:

- Your stove and chimney connector will be far enough from combustible material to meet all clearance requirements.
 - The floor protector is large enough and is constructed properly to meet all requirements.
 - You have all necessary permits from local authorities.
- Your local building official is the final authority for approving your installation as safe and determining that it meets local and state codes.

The metal label permanently attached to the back of every Vermont Castings' stove indicates that the stove has been tested to current UL and ULC standards, and gives the name of the testing laboratory. Clearance and installation information also is printed on the label. When the stove is installed according to the information both on the label and in this manual, local authorities in most cases will accept the label as evidence that the installation meets codes and can be approved.

However, codes vary in different areas. Before starting the installation, review your plans with the local building authority. Your local dealer can provide any additional information needed.

For any unresolved installation issues, refer to the National Fire Protection Association's publication *ANSI/NFPA 211 Standard for Chimneys, Fireplaces, Vents and Solid Fuel Burning Appliances*. For Canada, the equivalent publication is *CSA CAN-B365 Installation Code for Solid Fuel Burning Appliances and Equipment*. These standards are the basis for many national codes. They are nationally recognized and are accepted by most local authorities. Your local dealer or your local building official may have a copy of these regulations.

IMPORTANT: FAILURE TO FOLLOW THESE INSTALLATION INSTRUCTIONS MAY RESULT IN A DANGEROUS SITUATION, INCLUDING A CHIMNEY OR HOUSE FIRE. FOLLOW ALL INSTRUCTIONS EXACTLY, AND DO NOT ALLOW MAKESHIFT COMPROMISES TO ENDANGER PROPERTY AND PERSONAL SAFETY.

Outside Air

In some modern, super-insulated homes, there is inadequate air for combustion because of insufficient air infiltration into the building. Such air enters a home through unsealed cracks and openings. Exhaust fans for kitchen or bath can compete with the stove for available air and compound the problem.

When poor draft is caused by a low infiltration rate, opening a ground floor window on the windward side of the house and in the vicinity of the stove will usually alleviate the problem.

Another solution is to install a permanent outside air supply to the stove and/or room. In fact, bringing air for combustion from outside the home directly to the air inlet of the stove is required for new construction in some areas.

Pressure variations within the house do not affect a stove equipped with an outside air supply, and improved stove performance often results. An Outside Air Adaptor Kit for the Encore is available from your local Vermont Castings dealer.

Chimney Height

Altitude affects chimney performance. When using a 6" flue collar on the Encore, refer to Figure 1 for suggested chimney heights at various altitudes. Chimney height should be measured from the flue collar to the top of the chimney. The recommended minimum chimney height is 16'.

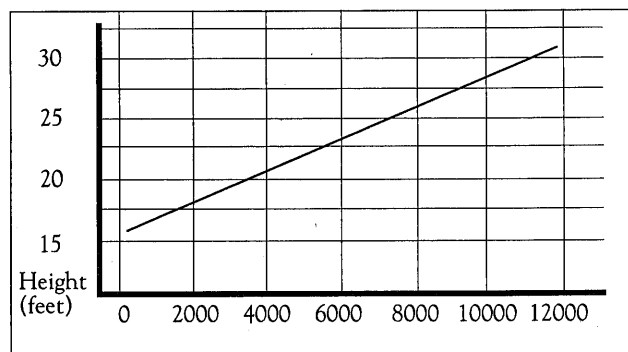

Fig. 1. Chimney height requirements for Encore when equipped with a 6" chimney.

What Kind of Chimney to Use

You must connect the Encore to a code-approved masonry chimney with a flue liner, to a relined masonry chimney that meets local codes, or to a prefabricated metal chimney that complies with the requirements for Type HT chimneys in the Standard for Chimneys, Factory-Built, Residential Type and Building Heating Appliance, UL 103. See Fig. 2. The chimney and chimney connector must be in good condition and kept clean.

If you use an existing masonry chimney, it must be inspected to ensure it is in a safe condition before the stove is installed. Your local professional chimney sweep, building inspector, or fire department official will be able to inspect the chimney or provide a referral to someone who can.

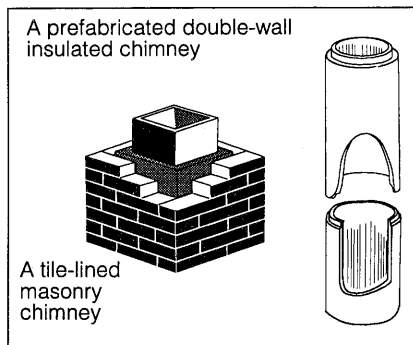

Fig. 2. Approved chimney types.

The chimney should extend at least 3' (900 mm) above the highest point where it passes through a roof, and at least 2' (600 mm) higher than any portion of a building within 10' (3 m). See Fig. 3.

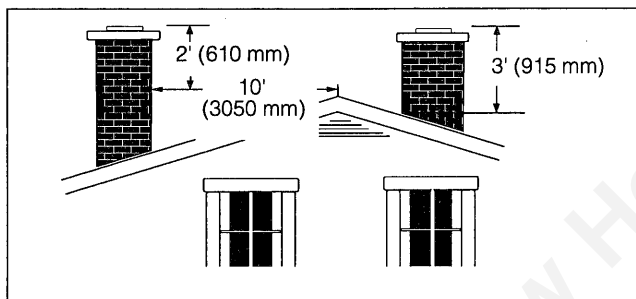

Fig. 3. Observe the 2/3/10 rule for chimneys.

For proper draft and good performance, any chimney used with an Encore should extend at least 16 feet (5 m) above the flue collar of the stove.

Masonry Chimneys

An inspection of the chimney must confirm that it has a lining. Do not use an unlined chimney. The chimney should have no cracks, loose mortar, other signs of deterioration, and blockage. Repair any defects before the chimney is used with your stove.

Unused openings in an existing masonry chimney must be sealed with masonry to the thickness of the chimney wall, and the chimney liner should be repaired. Openings sealed with pie plates or wallpaper are a hazard and should be sealed with mortar or refractory cement. In the event of a chimney fire, flames and smoke may be forced out of these unused thimbles.

The chimney should be thoroughly cleaned before use.

A newly-built masonry chimney must conform to the standards of your local building code or, in the absence of a local code, to a recognized national code. Masonry chimneys must be lined, either with code-approved masonry or pre-cast refractory tiles, stainless steel pipe, or a code-approved, "poured-in-place" liner. The chimney's clean-out door must seal tightly.

Prefabricated Chimneys

A prefabricated metal chimney must be one tested and listed for use with solid-fuel burning appliances to the High-Temperature (H.T.) Chimney Standard UL-103-1985 (2100° F.) for the United States, and High Temperature (650 C) Standard ULC S-629 for Canada.

DO NOT CONNECT THIS UNIT TO A CHIMNEY FLUE SERVING ANOTHER APPLIANCE.

Chimney Size

An Encore with an 8" (200 mm) flue collar is approved for venting into a masonry chimney with a nominal flue size of 8" x 8" (200 x 200 mm) or 8" x 12" (200 x 300 mm), and into a round flue with nominal flue size of 8" (200 mm). An Encore with a 6" (150 mm) flue collar is approved for venting into a masonry chimney with a nominal flue size of 8" X 8" (200 X 200 mm), and into a round flue with nominal flue of 6" (150 mm).

NOTE: When installed with a 6" flue collar, the Encore may not be operated with the front doors open.

Whatever the flue collar size, an Encore may be vented into larger chimneys as well. However, chimneys with liners larger than 8" X 12" (200 X 300 mm) may experience rapid cooling of smoke and reduction in draft, especially if the chimneys are located outside the home. These large chimneys may need to be insulated or have their flues relined for proper stove performance.

Accessories to help make the connection between stainless steel chimney liners and your Encore are available through your local dealer.

Chimney Connector Guidelines

A chimney connector is the double-wall or single-wall pipe that connects the stove to the chimney. The chimney itself is the masonry or prefabricated structure that encloses the flue. Chimney connectors are used only to connect the stove to the chimney, as in Fig. 5.

Double-wall connectors must be tested and listed for use with solid-fuel burning appliances. Single-wall connectors should be made of 24 gauge or heavier steel. Do not use galvanized connector; it cannot withstand the high temperatures that can be reached by smoke and exhaust gases, and may release toxic fumes under high heat. The connector may be 6" (150 mm) or 8" (200 mm) in diameter.

If possible, do not pass the chimney connector through a combustible wall or ceiling. If passage through a combustible wall is unavoidable, refer to the section on Wall Pass-Throughs. Do not pass the connector through an attic, a closet or similar concealed space. The whole connector should be exposed and accessible for inspection and cleaning.

In horizontal runs of chimney connector, maintain a distance of 24" (610 mm) from the ceiling. Keep it as short and direct as possible, with no more than two 90 degree turns. Slope horizontal runs of connector upward 1/4" per foot (20 mm per metre) going from the stove toward the chimney. The recommended maximum length of a horizontal run is 3 feet (1 metre), and the total length should be no longer than 8 feet (2.5 metres). In cathedral ceiling installations, extend the prefabricated chimney downward to within 8 feet (2.5 metres) of the stove.

Wear gloves and protective eyewear when drilling, cutting or joining sections of chimney connector.

Double-wall Chimney Connectors

Information on assembling and installing double-wall connectors is provided by the manufacturer of the double-wall pipe. Follow the manufacturer's instructions exactly as you assemble the connector and attach it to the stove and chimney. Using chimneys and connectors from the same manufacturer makes the assembly and installation straightforward.

NOTE: For installations using double-wall connectors, minimum clearances must conform to the listed clearances in the clearance chart on Page 11.

If the Encore is equipped with the 8" flue collar, an oval-to-round adaptor will be needed. Double-wall oval-to-round adaptors are available from some manufacturers. Your local dealer can help you select the right connector.

Single-wall Chimney Connectors

- Begin assembly at the flue collar of the stove. Insert the first crimped end into the stove's flue collar, and keep each crimped end pointing toward the stove. See Fig. 4. Using the holes in the flue collar as guides, drill 1/8" (3 mm) holes in the bottom of the first section of chimney connector and secure it to the flue collar with three #10 x 1/2" sheet metal screws.

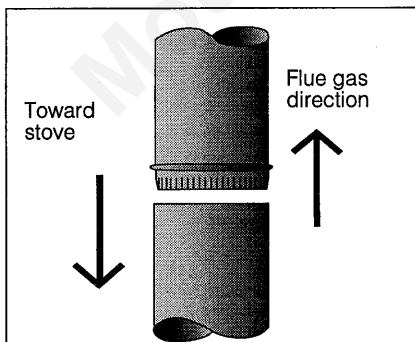

Fig. 4. The crimped end of the chimney connector should always point towards the stove. This layout keeps any condensed creosote inside the pipe system.

- Secure each joint between sections of chimney connector, including telescoping joints, with at least three sheet metal screws. The pre-drilled holes in the top of each section of chimney connector serve as guides when you drill 1/8" (3 mm) holes in the bottom of the next section.

- Secure the chimney connector to the chimney. Instructions for various installations follow.
- Be sure the installed stove and chimney connector are correct distances from nearby combustible materials.

Note: Special slip pipes and thimble sleeves that form telescoping joints between sections of chimney connector are available to simplify installations. They often eliminate the need to cut individual connector sections. Consult your local dealer about these special pieces.

Securing the Single-wall Connector to a Prefabricated Chimney

- Follow the installation instructions of the chimney manufacturer exactly as you install the chimney. The manufacturer of the chimney will supply the accessories to support the chimney, either from the roof of the house, at the ceiling of the room where the stove is installed, or from an exterior wall.

Special adaptors are available from your local dealer to make the connection between the prefabricated chimney and the chimney connector. The top of such adaptors attaches directly to the chimney or to the chimney's ceiling support package, while the bottom of the adaptor is screwed to the chimney connector.

These adaptors are designed so the top end will fit outside the inner wall of the chimney, and the bottom end will fit inside the first section of chimney connector. When assembled in this way, any soot or creosote falling from the inner walls of the chimney will stay inside the chimney connector.

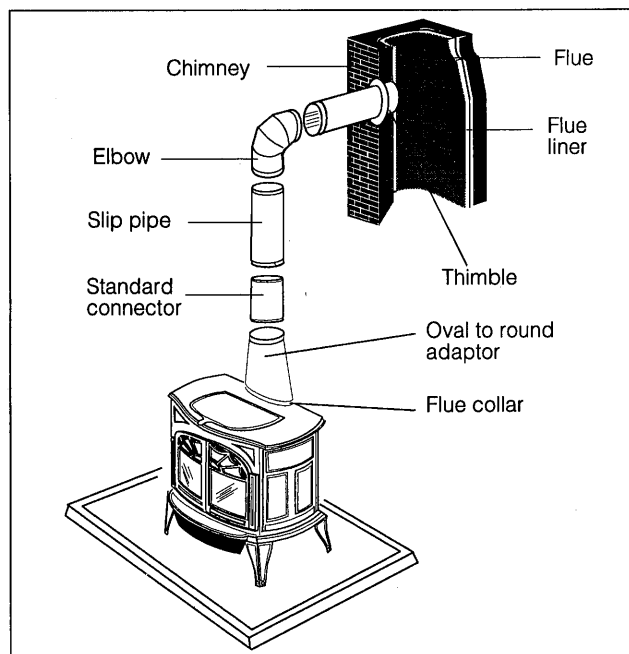

Fig. 5. An exploded view of the chimney connection in a freestanding masonry installation.

Securing the Single-wall Connector to a Masonry Chimney

Both freestanding masonry chimneys and fireplace masonry chimneys may be used for your installation.

Freestanding Installations

If the chimney connector must pass through a combustible wall to reach the chimney, follow the recommendations in the Wall Pass-Through section that follows.

The opening through the chimney wall to the flue (the "breach") must be lined with either a ceramic or metal cylinder, called the "thimble", which is cemented securely in place. Most chimney breeches incorporate thimbles, but the fit must be snug and the joint between the thimble and the chimney wall must be cemented firmly.

A special piece called the "thimble sleeve," slightly smaller in diameter than standard connectors and most thimbles, will facilitate the removal of the chimney connector system for inspection and cleaning. Thimble sleeves should be available from your local dealer.

To install a thimble sleeve, slide it into the breach until it is flush with the inner flue wall. Don't extend it into the actual flue passage, as this could interfere with the draft.

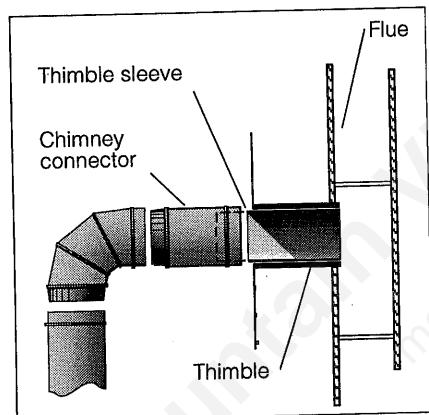

Fig. 6. The thimble, made of either ceramic or metal, must be cemented securely in place.

The thimble sleeve should protrude 1-2" (25-50 mm) into the room. See Fig. 6. Use furnace cement and thin gasketing to seal the sleeve in place in the thimble. Secure the chimney connector to the outer end of the sleeve with sheet metal screws.

Without a thimble, a suitable length of chimney connector can be extended through the breach to the inner face of the flue liner, and cemented securely in place. Additional pieces of connector are then attached with sheet metal screws.

Fireplace Installations

The chimney connector may be connected to the chimney above the fireplace opening or through the fireplace.

Above the Fireplace

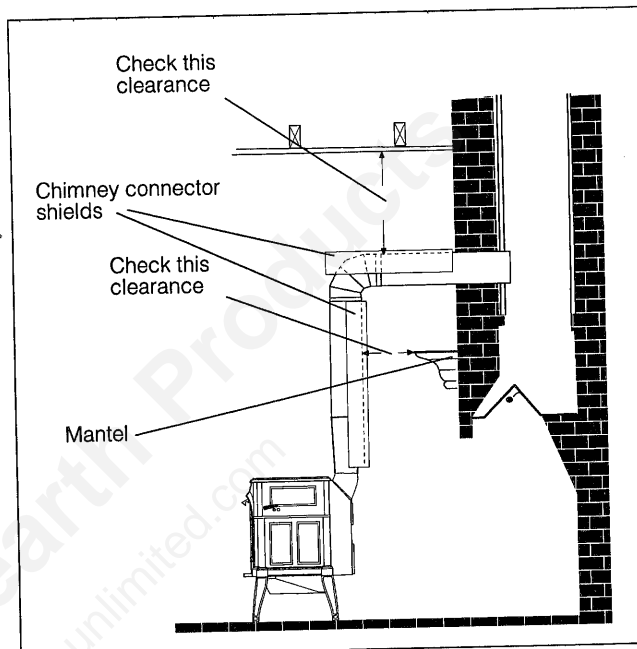

Fig. 7. In this installation, the chimney connector is attached to the chimney above the fireplace opening.

The Encore may be connected to a chimney above a fireplace opening as in Fig. 7. In such installations, the stove is positioned on the hearth in front of the fireplace and the chimney connector rises from the stove top and then angles ninety degrees back into the chimney. The chimney liner should extend to the point at which the chimney connector enters the chimney.

If the chimney connector from your installation enters the chimney above a fireplace, follow all the guidelines mentioned above for freestanding installations. In addition, give special consideration to the following points:

- Check the clearance between the stove and the chimney connector, and any combustible trim or the mantel. Use the necessary combination of mantel, trim, and connector heat shields to achieve the required clearances.
- Check the clearance between the chimney connector and the ceiling. If no heat shields are used, the clearance should be at least 24" (610 mm). To find out how much this clearance may be reduced with heat shields, see the clearance chart on Page 11.
- The fireplace damper must be sealed to prevent room air from escaping up the flue. However, it must be possible to re-open the damper to inspect or clean the chimney.

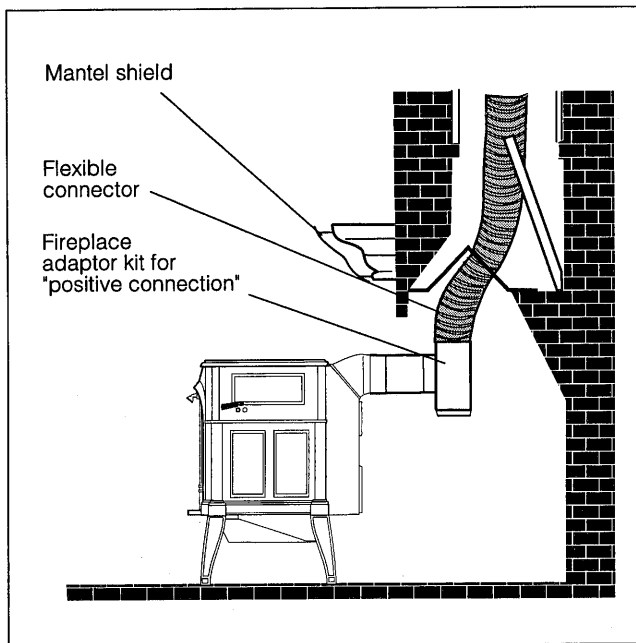

Fig. 8. In this installation, the chimney connector enters the fireplace opening and then connects to the chimney.

Through the Fireplace

If your fireplace opening height is at least 26-1/2" (675 mm), you may install an Encore through the opening using a "positive connection" kit, available from your local dealer. These positive connection kits ensure a tight fit between the stove flue collar and the chimney flue. Fig. 8 shows this type of installation.

Fireplace installations, whether connected to the flue above or through the fireplace opening, have special clearance requirements to adjacent trim and the mantel. You'll find the required safe clearances for Encore fireplace installations on Page 9.

Floor protection requirements also apply to fireplace installations. This information is on Page 6-7.

Wall Pass-Throughs

Whenever possible, design your installation so that the connector does not pass through a combustible wall. If you are considering a wall pass-through in your installation, check with your building inspector before you begin. Also, check with the chimney connector manufacturer for any specific requirements.

Accessories are available for use as wall pass-throughs. If using one of these, make sure it has been tested and listed for use as a wall pass-through.

In the United States, the National Fire Protection Association (NFPA) has established guidelines for passing chimney connectors through combustible walls. Many building code inspectors follow these guidelines when approving installations.

Figure 9 shows one NFPA-recommended method. All combustible material in the wall is cut away from the single-wall connector to provide the required 12" (300 mm) clearance. Any material used to close up the opening must be non-combustible.

- Three other methods are also approved by the NFPA:
- Using a section of double-wall chimney with a 9" (230 mm) clearance to combustibles.
 - Placing a section of chimney connector inside a ventilated thimble, which in turn is separated from combustibles by 6" (150 mm) of fiberglass insulating material.
 - Placing a section of chimney connector inside a section of 9" (230 mm) diameter, solid-insulated, factory-built chimney, with two inches of air space between the chimney section and combustibles.

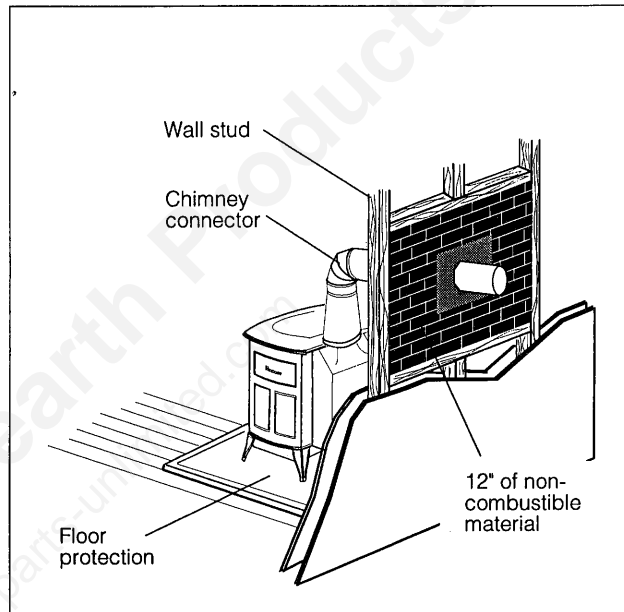

Fig. 9. An approved wall pass-through for the United States.

In Canada, The Canadian Standards Association has established different guidelines. Figure 10 shows one method, in which all combustible material in the wall is cut away to provide the required 18" (460 mm) clearance for the connector. The resulting space must remain empty. A flush-mounted sheet metal cover may be used on one side only. If covers must be used on both sides, each cover must be mounted on non-combustible spacers at least 1" (25 mm) clear of the wall.

Your local dealer or your local building inspector can provide details for other approved methods of passing a chimney connector through a combustible wall in your area. In Canada, this type of installation must conform to CAN/CSA-B365, Installation Code for Solid Fuel Burning Appliances and Equipment.

NOTE: Do not vent your Encore into a factory-built (zero-clearance) fireplace. These appliances and their chimneys are specifically designed as a unit for use as fireplaces. It may void the listing or be hazardous to adapt them for any other use.

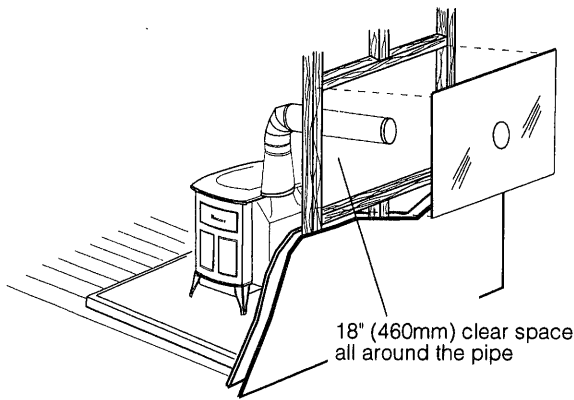

Fig. 10. An approved wall pass-through for Canada.

DO NOT CONNECT AN ENCORE TO ANY AIR DISTRIBUTION DUCT OR SYSTEM.

FLOOR PROTECTION

The floor beneath the stove requires protection from radiant heat and direct contact with sparks or embers.

Heat protection is provided by optional Vermont Castings Bottom Heat Shield Kit, #0164.

Spark and ember protection must be provided by a floor protector constructed with non-combustible material as specified below.

For a new hearth, we recommend a floor protector constructed of non-combustible material such as 1/4" non-asbestos mineral board or its equivalent, or 24 gauge sheet metal. If carpeting is present, it must be removed before installation of the floor protector. The floor protector may be covered with a non-combustible decorative material if desired.

When using brick, tile, or stone for the decorative surface, individual pieces must be mortared so sparks cannot fall through.

United States:

Installations on any floor constructed of combustible materials will require the optional Bottom Heat Shield. The stove can be installed without the bottom heat shield only when it is placed on a completely non-combustible surface, such as unpainted concrete over earth.

A non-combustible floor protector is required under the stove. It must extend at least 16 inches (not including the ash lip) from the front of the stove (labeled "F" in Figure 11), and at least 6 inches from the sides and rear ("D" and "E" in Figure 11).

It must also extend under the chimney connector and 2 inches to either side ("C" in Figure 11). For the 8" (200 mm) connector, the protector must be a minimum of 12" (305 mm) wide. For the 6" (150 mm) connector, the protector must be 10" (255 mm) wide. The protector must be centered under the connector.

To meet these requirements, a floor protector must be at least 39" wide and 44" deep.

Canada:

Installation of the Encore is not permitted without the Bottom Heat Shield.

A non-combustible floor protector is required under the stove as well. The floor protector must extend 18 inches (460 mm) to the front (labeled "F" in Figure 11), and 8 inches (200 mm) from the sides and rear ("D" and "E" in Figure 11).

To meet these requirements, a floor protector must be at least 43" (1095 mm) wide and 48" (1220 mm) deep.

Floor protection also must extend under the chimney connector and 2 inches to either side ("C" in Figure 11). For the 8" (200 mm) connector, the protector must be a minimum of 12" (305 mm) wide. For the 6" (150 mm) connector, it must be at least 10" (255 mm) wide. The protector must be centered under the connector.

Floor protection can be any non-combustible material - tile, flagstone, brick, slate, etc. We advise the use of cement board as a base, to provide extra thermal protection to the floor below the hearth. Non-combustible floor protection must be at least 39" wide x 44" deep — 43" (1095 mm) wide x 48" (1220 mm) deep in Canada - this includes an area at least 16" deep (18" [460 mm] in Canada) in front of the stove.

In the United States, the additional floor protection and bottom heat shield are not required if the floor is completely non-combustible, (i.e.; cement on earth).

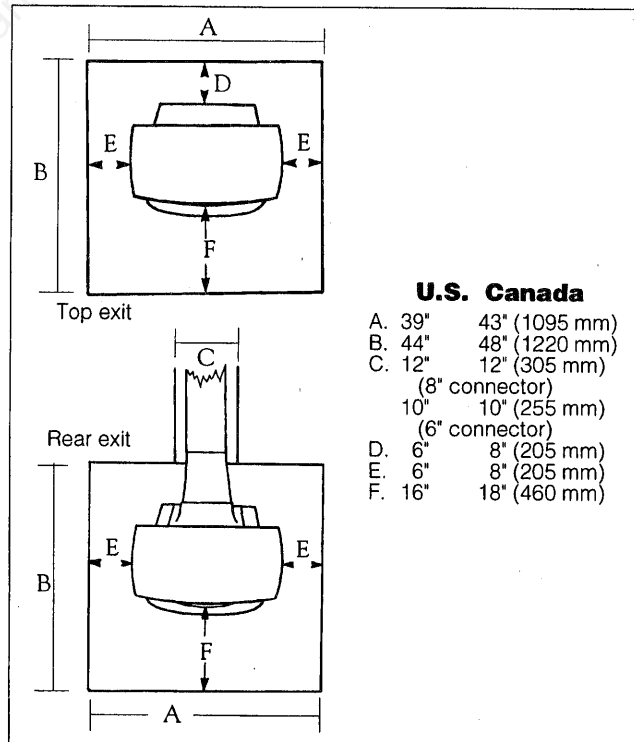

Fig. 11. Required floor protector dimensions for both top- and rear-exiting stoves.

Floor Protection for Fireplace Installations

Don't assume that your fireplace hearth is completely non-combustible.

Many fireplace hearths do not meet the "completely non-combustible" requirement because the brick or concrete in front of the fireplace opening is supported by heavy wood framing, as in Figure 12. Because heat passes through brick or concrete readily, it can easily pass through to the wood. As a result, such fireplace hearths can be a fire hazard and are considered a combustible floor.

Keep in mind, also, that many raised hearths will extend less than the required clearance from the front of the heater when it is installed. In such cases, sufficient floor protection as described above must be added in front of the hearth to satisfy the minimum floor protector requirement from the front of the stove: 16" (410 mm) from the front in the United States and 18" (460 mm) from the front in Canada.

Hearth rugs do not satisfy the requirements for floor protection.

Fireplace installations also have special clearance requirements to the side walls, side decorative trim, and fireplace mantle. This information follows in the section on Fireplace and Mantel Trim Shields.

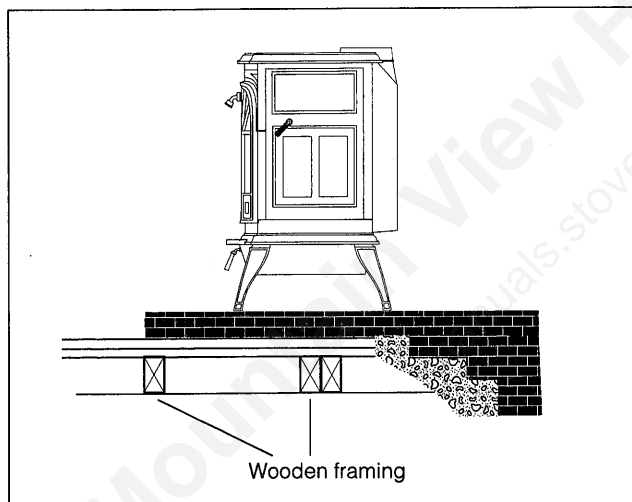

Fig. 12. Combustible supporting timbers may lie beneath fireplace hearths, requiring additional floor protection.

Keep the Stove a Safe Distance from Surrounding Materials

Both a stove and its chimney connector radiate heat in all directions when operating, and dangerous overheating of nearby combustible materials can occur if they are too close to the heat. A safe installation requires that adequate clearance be maintained between the hot stove and its connector and nearby combustibles.

Clearance is the distance between either your stove (measured from the bottom edge of the stove's top plate) or chimney connector, and nearby walls, floors, the ceiling, and any other fixed combustible surface. Your stove has special clearance requirements that have been

established after careful research and testing to UL and ULC standards. These clearance requirements must be strictly observed.

In addition, furnishings and other combustible materials must be kept away from the stove as well. In general, a distance of 48" (1220 mm) must be maintained between the stove and moveable combustible items such as drying clothes, furniture, newspapers, firewood, etc. Keeping those clearance areas empty assures that nearby surfaces and objects will not overheat.

Reducing Clearances Safely with Shields

Clearance requirements are established to meet every installation possibility, and they involve the combination of four basic variables:

- **When the stove and chimney connector have no listed heat shield mounted on them.**
- **When the stove and chimney connector have a listed heat shield mounted on them.**
- **When the wall has no listed heat shield mounted on it.**
- **When the wall has a heat shield mounted on it.**

In general, the greatest clearance is required when you place a stove and its connector with no heat shields near a wall with no heat shield.

For example, when the Encore is installed parallel to the rear wall and no shields are used, it must be at least 31" (790 mm) from the wall behind it and at least 24" (610 mm) from walls on either side.

If the Encore is installed in a corner and no shields are used, the corners of the stove must be at least 24" (610 mm) from nearby walls.

The least clearance is required when both the stove and its connector, as well as the wall, have heat shields.

When shields are attached to the stove or chimney connector, they are mounted 1" - 2" (25-50 mm) away from the stove or connector surface on non-combustible spacers. Air flowing between the stove (and/or chimney connector) and nearby shields carries away heat. Do not block the air flow by filling this empty space with any insulating material.

The shiny shield surface facing the heat source must be left unpainted, enabling it to reflect heat back towards the stove or connector and away from the wall.

Clearances may be reduced only by means approved by the regulatory authority, and in accordance with the clearances listed in this manual.

Because of their restricted air flow and heat retention characteristics, specific construction requirements and special clearances apply to installations into alcoves. Refer to the diagrams on page 10, and contact your Vermont Castings Dealer for details before beginning an alcove installation.

NOTE: ALCOVE INSTALLATION OF THE ENCORE IS NOT PERMITTED IN CANADA.

Stove Heat Shields

The Vermont Castings Encore Rear Heat Shield is one way to reduce the clearance to the rear wall. The rear heat shield can be installed on either rear- or top-venting stoves. However, since the chimney connector also radiates heat toward the wall in top-venting installations, you should use a chimney connector shield whenever you use the rear heat shield on top-venting stoves.

Clearance reductions with the rear heat shield apply only to the wall to the rear in parallel installations. Neither the side clearance requirement nor the clearance requirement in corner installations may be reduced.

Wall Shields

One way to reduce clearances is with a wall shield constructed of 24 gauge or heavier sheet metal, or of another non-combustible material such as 1/2" (13 mm) insulation board or common brick "laid on flat," with the 3-1/2" (90 mm) side down.

Shields must be spaced out from the combustible surface 1" (25 mm) on non-combustible spacers, as in Figure 13. The spacers should not be directly behind the stove or chimney connector.

Air must be able to flow between the wall and the shield. At least 50% of the bottom 1" (25 mm) of the shield should be open and the shield must be open at the top. Use metal screening, as in Figure 14, to keep stray objects from falling behind the shield.

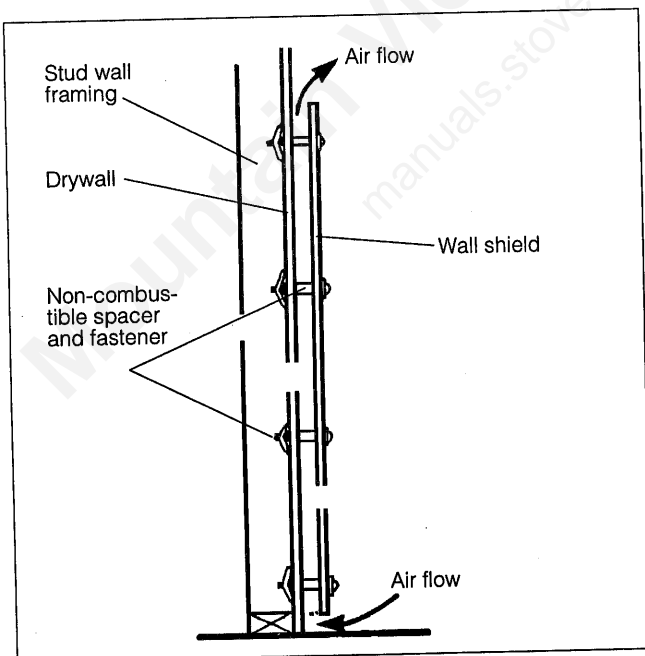

Fig.13. Wall shields must be spaced out from the combustible surface 1" (25 mm) on non-combustible spacers.

The shield for a top-exit stove must extend 10" (250 mm) above the top of the stove; for a rear exit configuration, the shield must be 36" (910 mm) high. The shield for the chimney connector must be 30" (760 mm) wide, centered behind the pipe; for installations that use an approved prefabricated chimney to pass through the ceiling, the chimney connector shield must stop 1" (25 mm) below the ceiling.

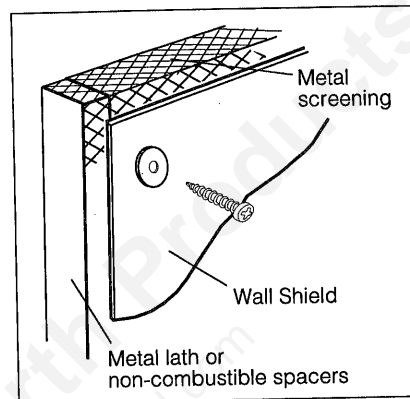

Fig. 14. Metal screening placed over the top of a wall shield will prevent small objects from falling behind it.

Chimney Connector Heat Shields

Chimney Connector Heat Shields should be used whenever the rear heat shield is used, or in any other situation when it is necessary to protect nearby combustibles from the heat of the connector. The ceiling above horizontal runs of chimney connector must be protected as well if the clearance is inadequate.

In top-exiting installations, the connector shield must extend to a point exactly 28" (710 mm) above the flue collar or to an elbow in the connector, whichever is less. If the top-exiting connector extends to the ceiling where it connects with a prefabricated insulated metal chimney, an additional ceiling heat shield must be installed that is 24" (610 mm) in diameter and that extends 1" (25 mm) below the ceiling. The ceiling shield must be constructed of 24 gauge or heavier sheet metal, and must be centered on the chimney.

Fireplace and Mantel Trim Shields

A fireplace installation requires special clearance between the side of the stove and the right and left walls, between the side of the stove and the decorative side trim on the fireplace face, and between the top of the stove and the mantel.

Non-combustible shields installed 1" (25 mm) away from the combustible surface on non-combustible spacers, called ventilated shields, may be used to reduce clearances.

To protect a mantel from the heat of an Encore in a fireplace installation, use a custom-made ventilated mantel shield that is at least 48" (1220 mm) long, that is centered over the stove. See Fig. 15. Ventilated shields for side trim must extend the full length of the trim.

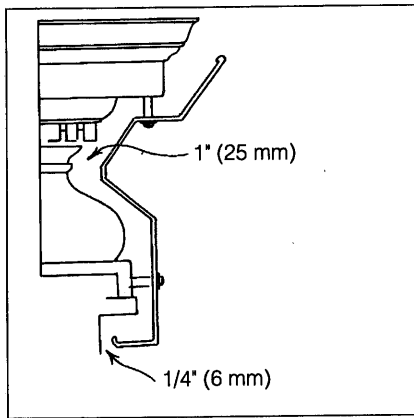

Fig. 15. A custom-formed mantel shield.

An unprotected mantel ("A" in Fig. 16) cannot be more than 9" (230 mm) deep and must have a minimum clearance of 39" (990 mm), measured from the stove's top plate. With a ventilated shield, this clearance may be reduced safely to 18" (460 mm).

Unprotected top trim (B) protruding 9" (230 mm) or less from the face of the fireplace must be a minimum of 39" (990 mm) from the stove's top surface. With a ventilated trim shield, this clearance may be reduced safely to 18" (460 mm).

Unprotected side trim (C) that protrudes 2" (50 mm) or less from the face of a fireplace must have a minimum clearance of 10" (250 mm), measured from the stove's top side edge. With a ventilated trim shield, the clearance may be reduced safely to 8" (200 mm). If the trim extends more than 2" (50 mm), it is subject to the requirements for wall clearance.

The charts and sample installations that follow list all the clearances required for the various installation configurations of the Encore.

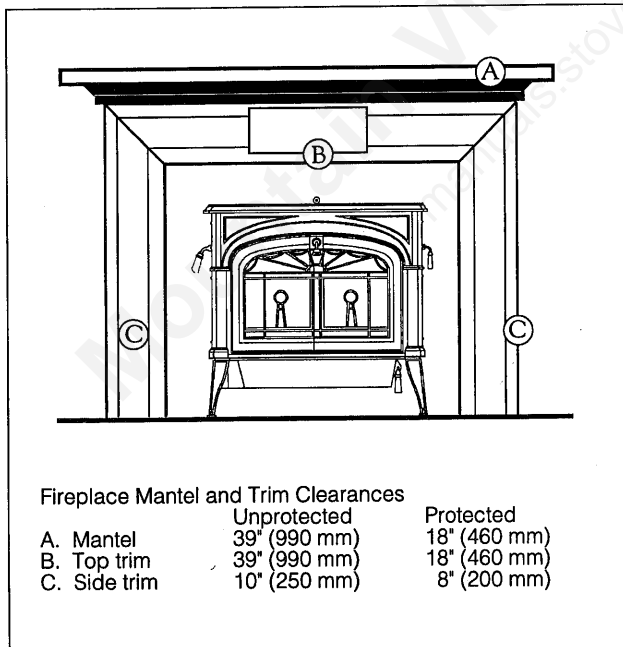

Fig. 16. Maintain clearances to combustible components of the mantelpiece.

Alcove Installations

Because of their restricted air flow and heat retention characteristics, alcove installations have specific construction requirements and special clearances. No rear stove or chimney connector heat shields are used in alcove installations. Bottom heat shield requirements remain the same as for other installations.

ALCOVE INSTALLATION OF THE ENCORE IS NOT PERMITTED IN CANADA.

Construction Requirements

The following illustrations show non-combustible ceiling framing and maximum and minimum permitted dimensions for alcove construction.

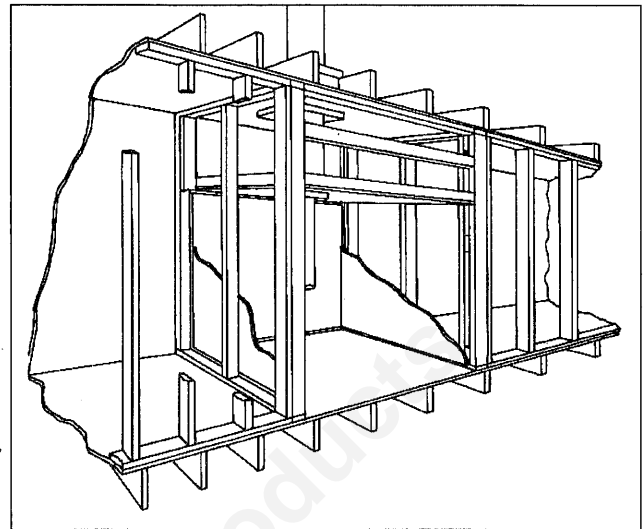

Fig. 19. Cutaway perspective of alcove installation.

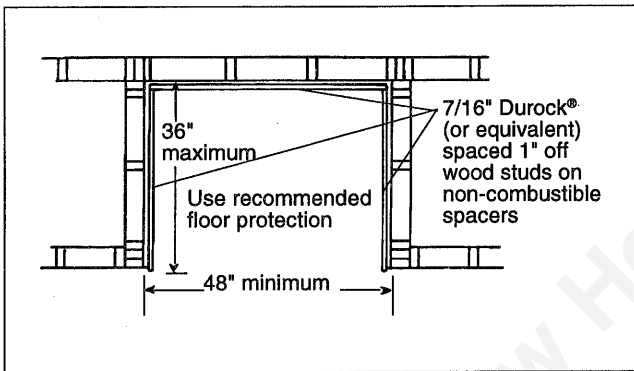

Fig. 17. Floor plan. Sheetrock on front face butts to Durock® (or equivalent) alcove lining.

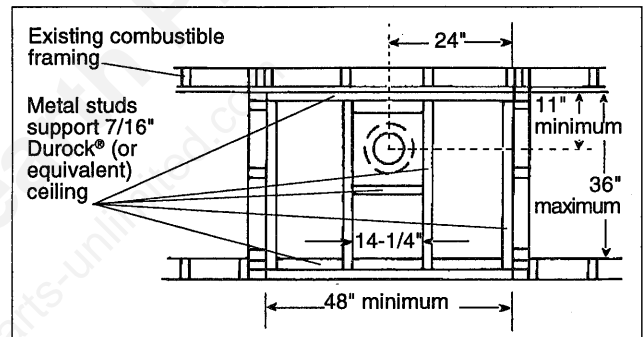

Fig. 20. Reflected ceiling plan.

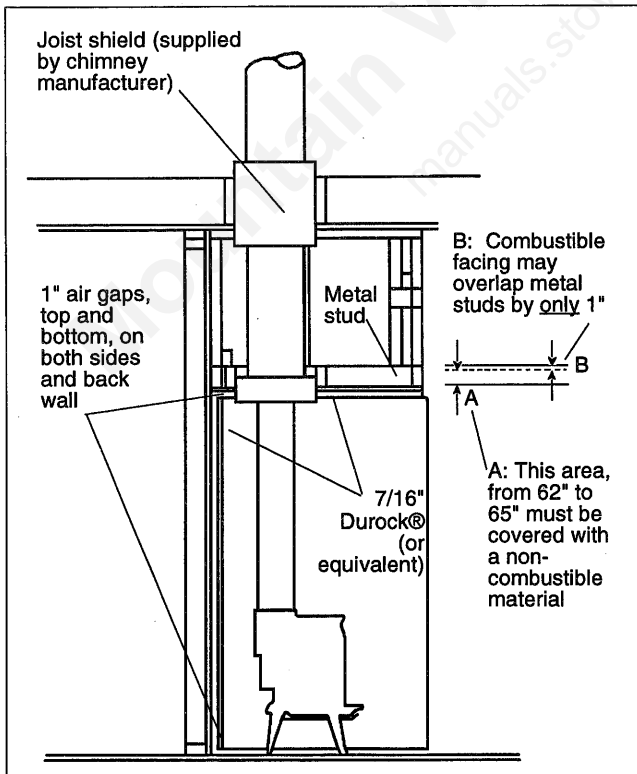

Fig. 18. Side section.

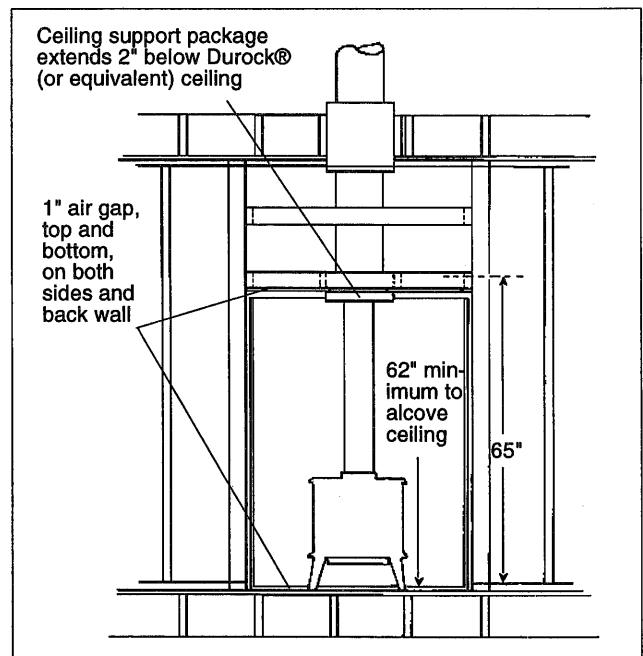

Fig. 21. Front section: 65" minimum clearance from finished floor surface to combustibles on front face. Combustible facing may overlap metal studs by only 1". It should not extend below the height of the non-combustible ceiling.

ENCORE CLEARANCE CHART:

for use with either a 6" or 8" flue collar/chimney connection

	STOVE CLEARANCE					
	<i>Unprotected Surfaces</i>			<i>Protected Surfaces</i>		
	Stove Installed Parallel to Wall		Stove in Corner	Stove Installed Parallel to Wall		Stove in Corner
	Side	Rear	Corners	Side	Rear	Corners
<i>No stove heat shields</i>	(A) 24" (610 mm)	(B) 31" (790 mm)	(C) 24" (610 mm)	(D) 8" (200 mm)	(E) 15" (380 mm)	(F) 8" (200 mm)
Top exit, rear stove h.s., single-wall chimney connector with connector heat shields ¹	(G) 24" (610 mm)	(H) 19" (480 mm)	(I) 17" (430 mm)	(J) 8" (200 mm)	(K) 11" (280 mm)	(L) 7" (180 mm)
Rear exit, rear stove heat shield only	(M) 24" (610 mm)	(N) 19" (480 mm)	N/A	(P) 8" (200 mm)	(Q) 11" (280 mm)	N/A
Top exit, rear stove h.s., double-wall chimney connector ³	(G) 24" (610 mm)	(H) 19" (480 mm)	(I) 24" (610 mm)	*		
	CHIMNEY CONNECTOR CLEARANCE					
	<i>Unprotected Surfaces</i>			<i>Protected Surfaces</i>		
<i>Single-wall connector, No chimney connector heat shields</i>	24" (610 mm)			8" (200 mm)		
<i>Single-wall connector, Chimney connector heat shields installed</i>	12" (300 mm)			4" (100 mm) ²		
<i>Double-wall connector</i> ³	12" (300 mm)			*		
	CLEARANCE TO COMBUSTIBLES IN FRONT OF STOVE					
	<i>All Installations</i> (S) 48" (1220 mm)					

* Clearances with double-wall connectors and protected surfaces have not been tested for the Encore.

1. A ceiling heat shield, 24" (610 mm) in diameter and suspended 1" (25 mm) from the ceiling, must surround the chimney connector in installations in which the chimney connector penetrates the ceiling. The chimney connector shield extends only to 28" (710 mm) above the flue collar.

2. The ceiling heat shield required when the chimney connector shields are used should meet the wall protector. This will require trimming the ceiling shield along the line of intersection with the wall protector.

3. In top-exit installations, this clearance requires the use of a rear stove heat shield with the flue collar insert installed.

Encore Clearance Diagrams: Use with either 6" or 8" flue collar/chimney connector

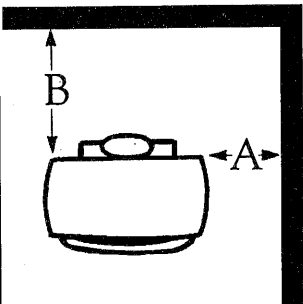
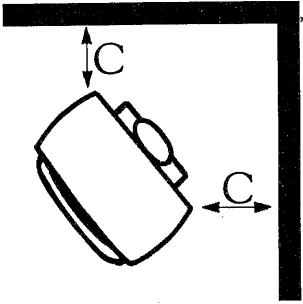
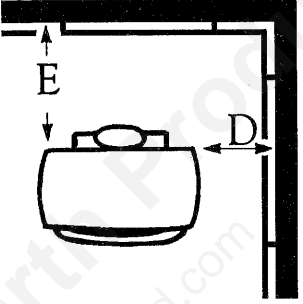
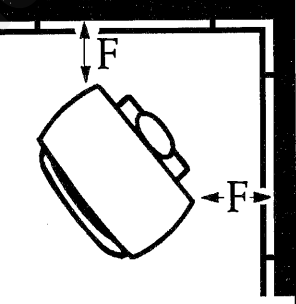
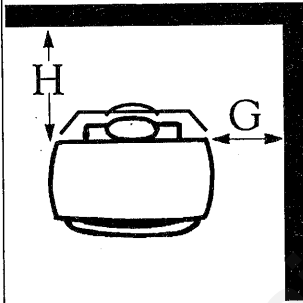
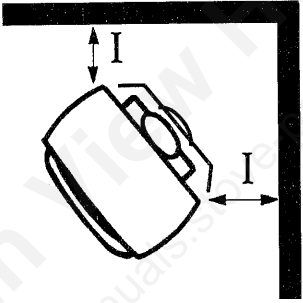
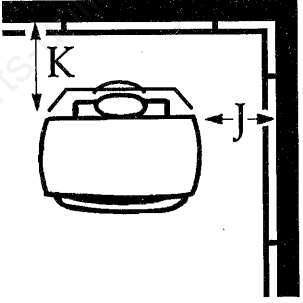
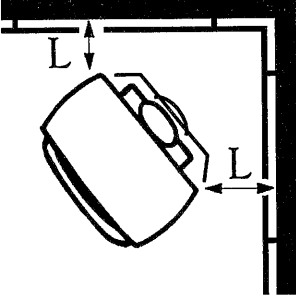
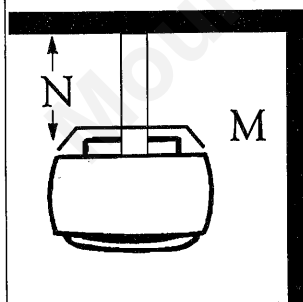
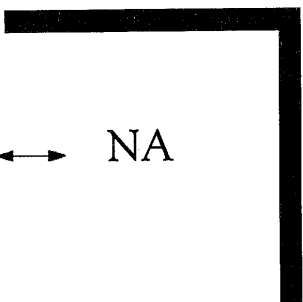
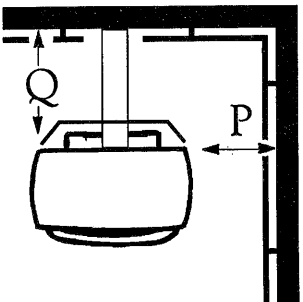
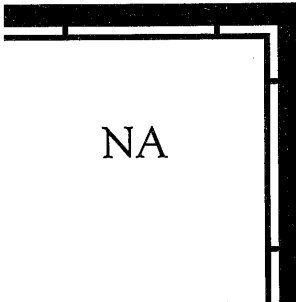
<i>Unprotected Surfaces</i>		<i>Protected Surfaces</i>	
Stove Installed Parallel to Wall	Stove in Corner	Stove Installed Parallel to Wall	Stove in Corner
<i>Top Exit Installations, no heat shields</i>			
			
<i>Top Exit Installations, rear heat shield, and chimney connector heat shields or double-wall connector</i>			
			
<i>Rear Exit Installations, rear heat shields</i>			
			

Wall Shield Requirements for Some Common Encore Installations

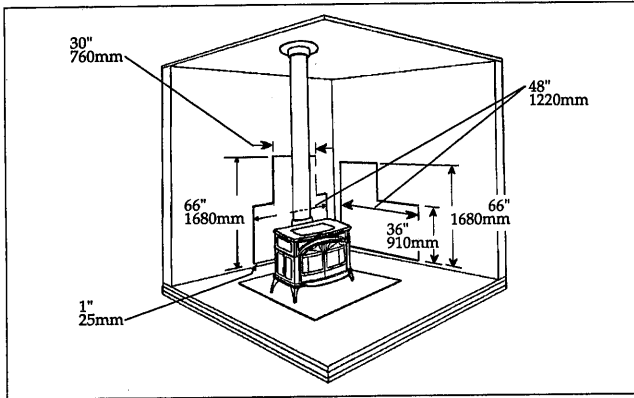

Fig. 22. Parallel installation, vertical chimney connector, two wall shields. Reduced clearances for both rear and side walls. Wall shields may meet at corner if desired. Shielding for connector is centered behind connector.

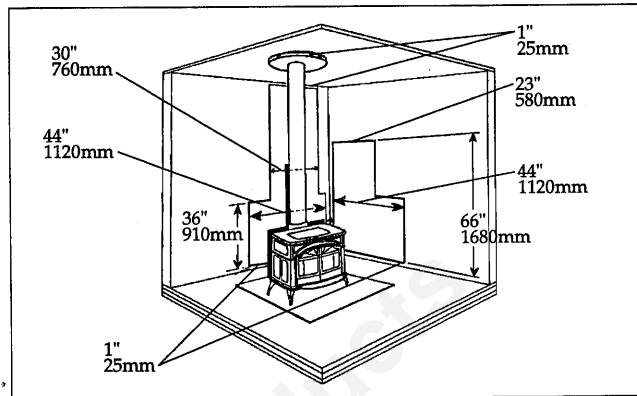

Fig. 23. Parallel installation, vertical chimney connector, with stove, connector and wall shields. Maximum reduction for both rear and side walls. Wall shields may meet at corner if desired. A heat shield 24" (610mm) in diameter suspended 1" (25mm) below the ceiling must surround the chimney.

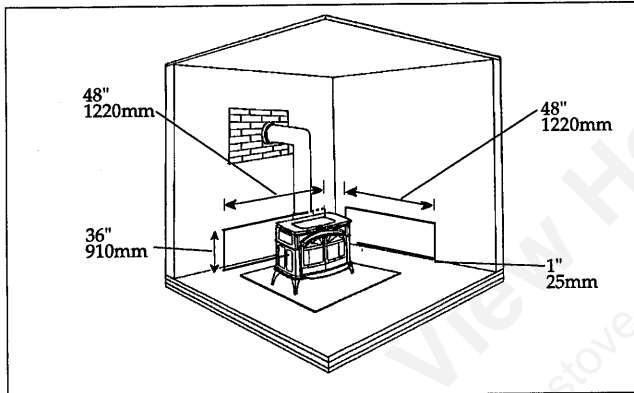

Fig. 24. Parallel installation with rear wall pass-through, two wall shields. Reduced clearances to both rear and side walls. Wall shields may meet at corner if desired. Shielding for connector is centered behind connector. Wall pass-through must comply with codes. See "Special Installations".

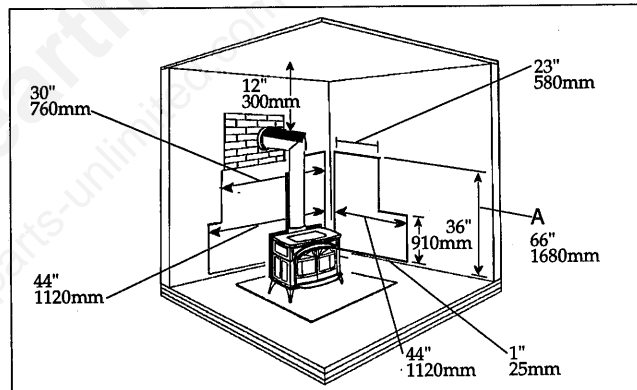

Fig. 25. Parallel installation with rear wall pass-through with stove, chimney connector and wall shields. Wall shields may meet at corner if desired. Connector shield extends 28" (710mm) above flue collar, or to the elbow, whichever is less. Height "A" must be 66" (1680mm) or reach the thimble. Pass-through must comply with codes. See "Special Installations".

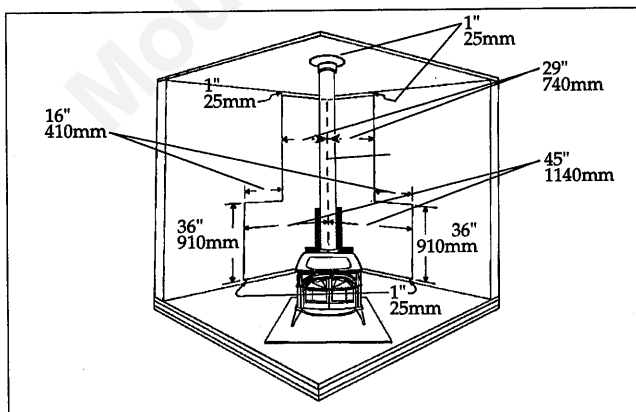

Fig. 26. Corner installation, vertical chimney connector, with rear, stove, chimney connector and wall shields. Wall shields MUST meet at corner. Connector heat shield extends 28" (710 mm) above flue collar. A 24" (610 mm) diameter ceiling heat shield must surround the chimney and be suspended 1" (25mm) from ceiling.

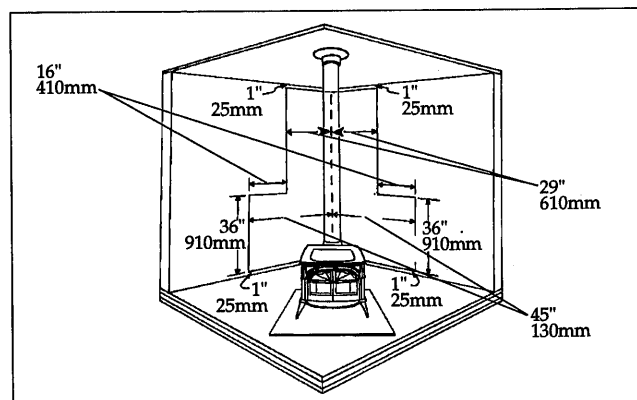

Fig. 27. Corner installation, vertical chimney connector, two wall shields. Reduced side clearances. Wall shields MUST meet at corner.

Distance from the Center of the Flue Collar to the Wall in Top-Exit Installations

The information on this page is helpful in planning stove placement for top-exiting installations, particularly those installations with chimneys that pass through the ceiling. However, this is not a clearance chart. Final stove clearances must adhere to the guidelines stated in the clearance chart on Page 11.

Dimensions indicated are valid for installations with either 6" or 8" flue collars.

Encore: WITHOUT Stove and Chimney Connector Heat Shields

Unprotected Surfaces			Protected Surfaces		
Parallel Installations		Corner Installations	Parallel Installations		Corner Installations
Side (A)	Rear (B)	Corner (C)	Side (D)	Rear (E)	Corner (F)
37-1/2" 960mm	27-3/4" 710mm	31" 790mm	21-1/2" 550mm	11-3/4" 300mm	15" 380 mm

* This distance, from the center of the flue collar to the front edge of the hearth, is the same for all installations on this page: 35" in the United States and 37" (940 mm) in Canada.

Encore: WITH Stove and Chimney Connector Heat Shields

Unprotected Surfaces			Protected Surfaces		
Parallel Installations		Corner Installations	Parallel Installations		Corner Installations
Side (A)	Rear (B)	Corner (C)	Side (D)	Rear (E)	Corner (F)
37-1/2" 960mm	15-3/4" 410mm	24" 610mm	21-1/2" 550mm	7-3/4" 200mm	14" 360mm

**To locate center of flue collar for corner installation, add 7" (180 mm) to the clearance dimension from stove corner to wall. Mark off the resulting dimension from the corner along both walls. Next, measure the same distance from these two points out from the walls. These last two measurements will meet at a point representing the center of the flue collar. Refer to the diagrams above.

Assembly

Set Up Your Stove

Cast iron stoves are heavy, and it will take between two and four people to move your Encore into position.

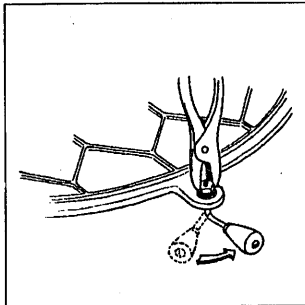

Fig. 28. Attaching the griddle handle.

Wipe the protective coating of oil from the griddle with a clean dry rag or a paper towel.

Install the handle on the griddle. First, place the griddle upside down at the edge of a flat surface and assemble the handle as shown.

With the handle pointing 45 degrees from its final position, tighten the nut as far as possible with the pliers. Move the handle to its final position while still holding the nut with the pliers.

Install the optional Bottom Heat Shield

NOTE: The Bottom Heat Shield is required in all Canadian and most U.S. installations. See Floor Protection, Page 6, for further details.

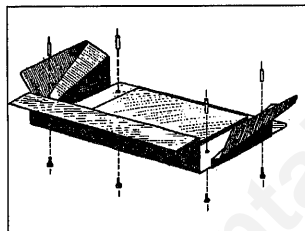

Fig. 29. Use four spacers to attach the bottom heat shield.

1. Remove the four 10-24 x 1/2" hex head bolts from the corners of the ash drop on the stove bottom.
2. Screw the four 1-1/4" spacers into the holes from which you removed the bolts, finger-tight.
3. Align the bottom heat shield against the spacers with the stepped side toward the rear of the stove.

4. Secure the shield with the four hex head bolts removed from the stove bottom previously.
5. Tighten securely.

Adjust the Leg Levellers

Lift the stove slightly so there is no weight on the leg while making the adjustment.

Reverse the Flue Collar (If Necessary)

Reverse the flue collar by removing the two screws that attach it to the back of the stove. Be sure the gasket around the flue collar opening is in position when you screw the collar back onto the stove.

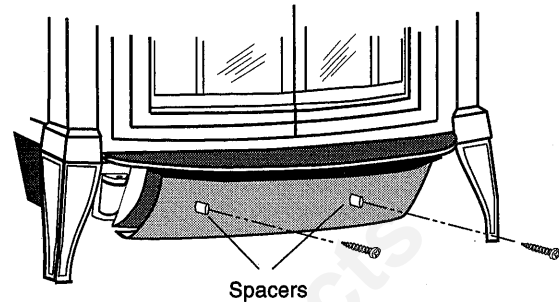

Fig. 30. Use spacers and screws to position the ash door heat shield.

Install the Ash Door Heat Shield

1. Remove the two Phillips pan head screws from the ash door.
2. Insert the screws through the ash door heat shield (from the painted side), place the 5/16" spacers over the screws, and carefully thread them back into the original holes. The curved lip should be upward, under the ashlip of the stove.
3. Tighten securely.

Attach the Primary Air Thermostat Handle

The primary air thermostat handle is the smaller of the two black handles. Secure the handle to the stub on the right side of the stove with an 8-32 x 2" slot head machine screw.

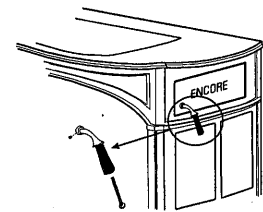

Fig. 31. Attaching the thermostat handle.

Attach the Damper Handle

Use the 1/4" -20 x 3" screw to attach the damper handle to the damper stub on the left side.

Assemble the Removable Insert Handle

The white removable insert handle opens and closes the front doors. Remove after each use so it won't get hot, and store it in the handle holder installed behind the right front leg. Assemble the handle by passing the 3-3/8" screw through the ceramic shaft and into the bright metal nub. Tighten carefully until snug.

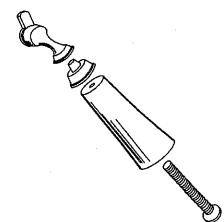

Fig. 32. Assemble the front door handle.

Operation

The Encore Controls

Two controls regulate the performance of the Encore: a **primary air control** supplies oxygen for the fire, and a **damper** directs air flow within the stove to activate and deactivate the catalytic combustor.

Symbols cast into the stove are reminders of the correct directions for opening and closing the controls. The symbols assume that you are facing the front of the stove.

A Single Air Control Regulates Heat Output and Burn Time.

The **primary air control lever**, located on the right side of the stove, controls the amount of incoming air for starting, maintaining, and reviving a fire.

More air entering the stove makes the fire burn hotter and faster, while less air prolongs the burn at a lower heat level. High and low settings appear in Fig. 33.

For the greatest air supply and maximum heat output (but the shortest burn time), move the lever toward the front of the stove. For a fire that will last longer with less heat, move the lever toward the rear of the stove.

The Encore's air control system also features an automatic thermostat to ensure an even heat output at whatever manual setting you select. The thermostat senses the heating and cooling of the stove surface and adjusts the air shutter accordingly.

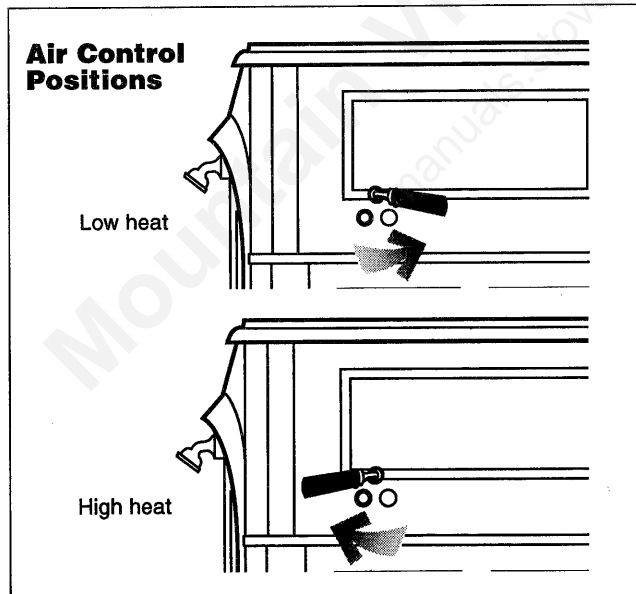

Fig. 33. The handle also may be positioned anywhere between the two extremes for different heat levels.

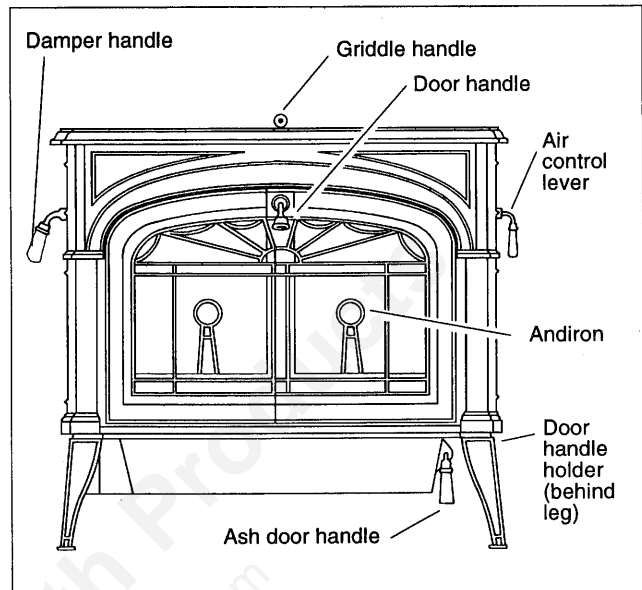

Fig. 34. The Encore controls are conveniently located and easy to operate.

A Damper Directs Air Flow Within the Stove

The **damper handle** on the left side of the stove opens and closes the damper to direct air flow within the stove.

The damper is **open** when the handle points **rearward**, enabling smoke to pass directly into the chimney. The damper must be open when starting or reviving a fire, and whenever the griddle or doors are opened.

The damper is **closed** when the handle points **forward**. Smoke from the fire is directed through the catalytic combustion system where it can be further burned for greater efficiency, before passing up the chimney.

When closing the damper, be sure to pull firmly enough to snap it into the locked position.

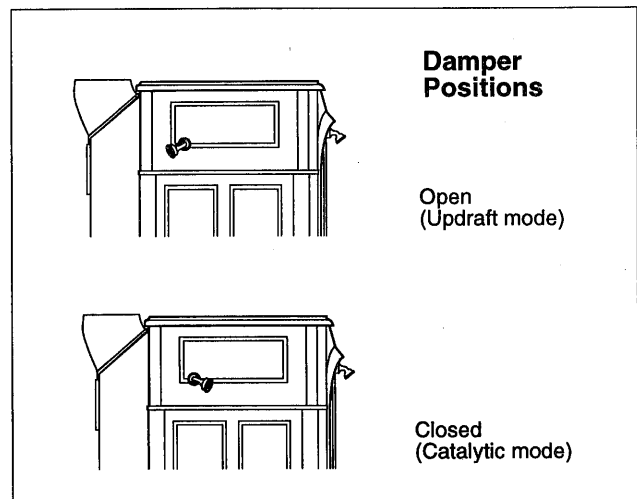

Fig. 35. The damper is either open or closed. There are no intermediate positions.

Two Ways to Add Fuel

The Encore's griddle lifts for convenient top-loading of logs, and is the easiest way to regularly add fuel.

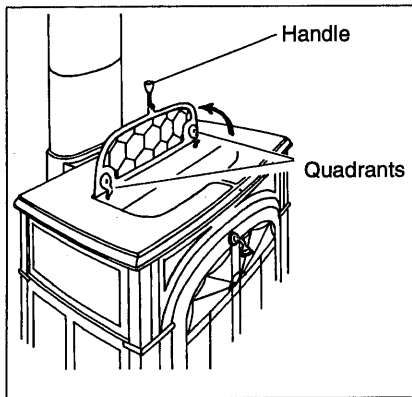

Fig. 36. The Encore's hinged griddle makes it easy to top-load wood.

However, the front doors open as well for adding an occasional log to a fire. If equipped with the 8" (200 mm) flue collar, the front doors may be opened (or even removed) and the optional Encore spark screen placed in the opening for open-fire viewing. **The Encore is not approved for operation with the front doors open if equipped with the optional 6" (150 mm) flue collar.**

To open the front doors, insert the handle into the door latch stub and turn it to the left and up, as in Fig. 37.

To close them, always close the left door first. Turn the handle in the right door to the left and up (to the open position) and close it. Finally, push on the door as you turn the handle to the right and down. The doors will draw in slightly, and the handle should offer some resistance as you turn it to the closed position.

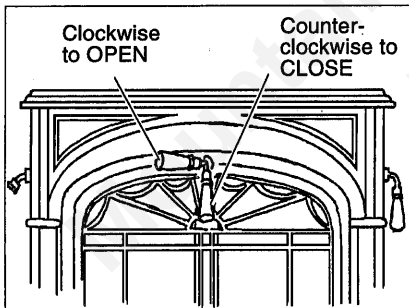

Fig. 37. To open the front doors, turn the handle clockwise.

To reduce the risk of breaking the glass, avoid striking the glass or slamming the doors.

When you're not using the door handle, store it in the holder behind the right front leg of the stove. See Fig. 34.

WARNING: FOR SAFETY AND GREATEST EFFICIENCY, OPERATE YOUR STOVE ONLY WITH ALL DOORS/GRIDDLES FULLY CLOSED. THE TEST STANDARD FOR YOUR STOVE WHEN IT IS OPERATED IN THIS MODE IS UL 1482.

THE ENCORE MAY BE USED AS A FIREPLACE WITH THE FRONT DOORS OPEN OR REMOVED, BUT ONLY WHEN IT IS EQUIPPED WITH AN 8" (200MM) FLUE COLLAR AND ONLY WHEN THE OPTIONAL SPARK SCREEN IS PLACED CORRECTLY IN THE OPENING TO PROTECT AGAINST THE POSSIBILITY OF SPARKS AND EMBERS LEAVING YOUR STOVE. THE TEST STANDARD FOR YOUR STOVE WHEN IT IS OPERATED IN THIS MODE IS UL 737.

USE ONLY THE ENCORE SPARK SCREEN, ITEM #0127, WITH YOUR ENCORE.

ENCORE SPARK SCREENS ARE AVAILABLE FROM YOUR VERMONT CASTINGS' DEALER.

Infra-Red Reflective Glass Panels for Clear Fire Viewing

The inner surfaces of the **infrared reflective glass panels** are kept at a higher temperature than the outer surface. This design, along with a pre-heated 'airwash,' makes clear fire viewing possible at most levels of operation.

Andirons Help Protect the Glass

Your stove has andirons to keep logs away from the glass panels. The andirons are essential to maintain clear fire viewing, and should be left permanently in place. Since the andirons may slightly hinder refueling through the front doors, most stove owners will prefer the convenience of top loading through the griddle.

Burn Only High-Quality Wood

The Encore is designed to burn natural wood only; do not burn fuels other than that for which it was designed.

You'll enjoy the best results when burning wood that has been adequately air-dried. Avoid burning "green" wood that has not been properly seasoned, or cordwood dried more than two years. **Do not burn construction materials;** they often contain chemicals and metals that can damage the catalytic combustor. The wood should be 18-20" (400-500 mm) in length.

The best hardwood fuels include oak, maple, beech, ash, and hickory that has been split, stacked, and air-dried outside under cover for at least one year.

If hardwood is not available, you can burn softwoods like include tamarack, yellow pine, white pine, Eastern red cedar, fir, and redwood. These too should be properly dried.

Store wood under cover to keep it dry. The longer it is stored, the better heating and fire-viewing performance you will enjoy. Even for short-term storage, however, keep wood a safe distance from the heater and keep it out of the areas around the heater used for refueling and ash removal.

A Surface Thermometer is a Valuable Guide to Operation

An optional surface thermometer lets you know when to adjust the air control, when to refuel, and when your catalyst is operating properly.

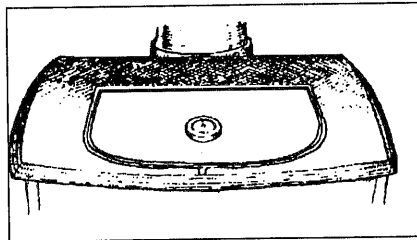

Fig. 38. Take temperature readings with the thermometer located in the middle of the griddle.

For example, when the thermometer registers at least 450° F. (230 C) after start-up you know that the stove is hot enough to begin catalytic combustion and that it may be time to close the damper. Note that the stove will warm up much sooner than the chimney, though; a warm chimney is the key to easy, effective stove operation. Please review the draft management information on pages 22-23 to see how the size, type, and location of your chimney will affect your stove operation. When thermometer readings drop below 350°F. (175°C) it's time to adjust the air control for a higher burn rate or to reload the stove. A temperature reading over 750° F. (385°C) is a sign to cut back on the air supply to slow the burn rate.

Use the following temperature ranges as a guide to operation:

- Readings in the 350-500°F. (175-260°C) range indicate low to medium heat output.
- 500-600°F. (260-315°C) readings indicate medium heat output.
- Readings of 600-750°F. (315-400°C) indicate high heat output. Operating your Encore continuously at griddle temperatures of 750° F. (385°C) or higher may damage the cast iron or enamel finish.

Use the Air Control Settings that Work Best for You

No single air control setting will fit every situation. Each installation will differ depending on the quality of the fuel, the amount of heat desired, and how long you wish the fire to burn; outdoor air temperature and pressure also affect draft.

The control setting also depends on your particular installation's "draft," or the force that moves air from the stove up through the chimney. Draft is affected by such things as the length, type, and location of the chimney, local geography, nearby obstructions, and other factors. See pages 22-23 for details on how the installation affects performance.

Too much draft may cause excessive temperatures in the Encore, and could even damage the combustor. On the other hand, too little draft can cause backpuffing into the room and/or the "plugging" of the chimney or com-

bustor.

How do you know if your draft is excessively high or low? Symptoms of too much draft include an uncontrollable burn or a glowing-red stove part. A sign of inadequate draft is smoke leaking into the room through the stove or chimney connector joints, low heat, and dirty glass.

In some newer homes that are well-insulated and weather-tight, poor draft may result from insufficient air in the house. In such instances, an open window near the stove on the windward side of the house will provide the fresh air needed.

Another option for getting more combustion air to the stove is to duct air directly from the outside to the stove. In some areas provisions for outside combustion air are required in all new construction.

Your Encore will accept a duct to deliver outside air for combustion.

When first using the stove, keep track of the air control settings. You will quickly find that a specific setting will give you a fixed amount of heat. It may take a week or two to determine the amount of heat and the length of burn you should expect from various settings.

Most installations do not require a large amount of combustion air, especially if adequate draft is available. **Do not for any reason attempt to increase the firing of your heater by altering the air control adjustment range outlined in these directions.**

Use the following air control settings as a starting point to help determine the best settings for your installation. Each is described as a fraction of the total distance the lever may be moved from right to left.

Encore Control Settings

Burn Rate	Primary Air Control
Low	From far right to 1/3 the distance to left
Medium	From 1/3 to 2/3 the distance to left
High	From 2/3 the distance to left to far left

High-Efficiency Wood Burning with Catalytic Combustion

An Encore leaves the factory with the combustor installed.

In the United States, it is against the law to operate this wood heater in a manner inconsistent with operating instructions in this manual, or if the catalytic combustor is deactivated or removed. The components of the catalytic combustion system in your Encore work together to produce optimum conditions for secondary combustion.

When the damper is closed, smoke travels through the catalytic element, which causes ignition of smoke at temperatures of 500-600° F (260-315 C), half the temperature normally required for unaided secondary combustion.

The catalytic element is a ceramic "honeycomb" coated with the catalytic material. The element is located in the secondary combustion chamber, molded from a special high-temperature insulating refractory material. The chamber provides the correct environment necessary for secondary combustion of the fuel (smoke).

Closing the damper expose the smoke to the combustor. If the combustor is at least 600° (F), it will begin to burn the smoke.

Closing the stove damper may also reduce the draft, so to avoid putting out the fire or deactivating the combustor, close the damper only when a fire is well-established. When starting a fire, wait until the fire is well established and there is an ember bed of at least 3-4 inches before closing the damper.

Never kindle a fire with colored paper or paper that has colored ink or a glossy surface, and never burn treated wood, garbage, solvents, or trash. All of these may poison the catalyst and prevent it from operating properly. Never burn cardboard or loose paper except for kindling purposes. Never burn coal; doing so can produce soot or large flakes of char or fly ash that can coat the combustor and cause smoke to spill into the room. Coal smoke also can poison the catalyst so that it won't operate properly.

In general, the fire must be sufficiently well-established to ensure that catalytic activity is initiated. When first starting a fire, a medium- to high- firing rate must be maintained until the stove, catalyst, and fuel are all stabilized at the proper operating temperatures.

Even though it is possible for the fire to get quite hot within a few minutes after a fire is started, the combustor may stop working or the fire may go out if the fire is allowed to die down immediately as a result of the damper being closed. Once the combustor starts working, heat generated by burning the smoke will keep it working.

To determine whether the combustor is operating, observe the amount of smoke leaving the chimney when the damper is activated and when it is not. This procedure is described on page 26.

Avoid using a full charge of very dry wood in the firebox. This may result in continuous very high temperatures in the secondary combustion area and damage the combustor. Wood which has been split, and stored under cover for more than 18 months may be considered very dry. Also, do not use a full load of dry slab wood or scrap wood. For long burns, use a mix of dry and moderately dry wood.

Conditioning Your Stove

Cast iron is extremely strong, but it can be broken with a sharp blow from a hammer or from the thermal shock of rapid and extreme temperature change.

The cast plates expand and contract with changes in temperature. When you first begin using your Encore, minimize thermal stress by allowing the plates to adjust gradually during three or four initial break-in fires following **Steps 1-3** below.

Starting and Maintaining a Wood Fire

Burn only solid wood in the Encore, and burn it directly on the grate. Do not elevate the fuel. Do not burn coal or other fuels.

THE DAMPER MUST BE OPEN WHEN STARTING A FIRE OR WHEN REFUELING. DO NOT USE CHEMICALS OR FLUIDS TO START THE FIRE. DO NOT BURN GARBAGE OR FLAMMABLE FLUIDS SUCH AS GASOLINE, NAPHTHA, OR ENGINE OIL.

1. Open the stove damper, and open the primary air control fully.
2. Place several sheets of crumpled newspaper in the stove. Do NOT use glossy advertisements or colored paper, as they can poison the catalyst. Place on the

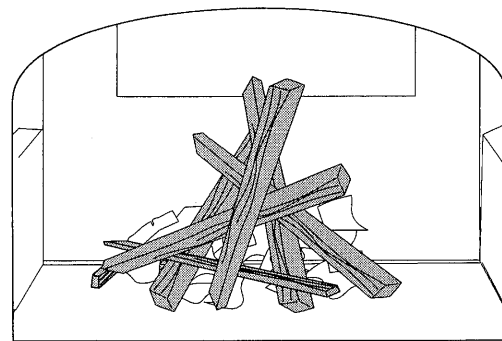

Fig. 39. Start the fire with newspaper and dry kindling.

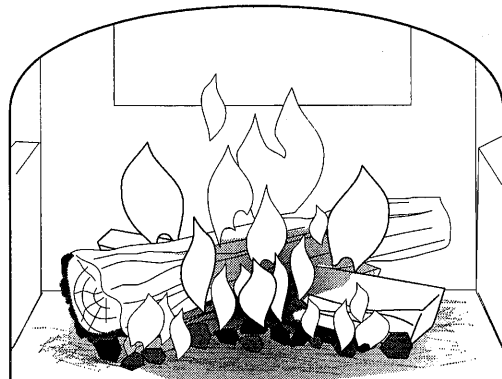

Fig. 40. Add larger pieces of wood as the fire begins to burn well.

paper six or eight pieces of dry kindling split to a finger-width size, and on the kindling lay two or three larger sticks of split dry wood approximately 1-2" (25-50 mm) in diameter.

Also, never use gasoline-type lantern fuel, kerosene, charcoal lighter fluid, or similar liquids to start or "freshen up" a fire. Keep all such liquids well away from the Encore while it is in use.

3. Light the newspaper and close the door. Gradually build up the fire by adding a few 3-5" (80-120 mm) diameter splits. **If this is one of the first few "break-in" fires, let the fire burn brightly, and then let it die out.**

During the break-in fires, don't let the stove get hotter than 500°F. (260 C) as measured on an optional stove-top thermometer. Adjust the air control lever as necessary to control the fire.

Some odor from the stove's hot metal, the paint, and the cement is normal for the first few fires.

NOTE: Some chimneys need to be "primed," or warmed up, before they will draw sufficiently to start a fire. To correct this situation, roll up a couple pieces of newspaper, place them on top of the kindling and toward the back of the stove, light them, and close the doors. This will encourage smoke to rise rapidly, encouraging a good draft.

Once the draft is established, open the front door and light the rest of the fuel from the bottom. Do not light the main bed of fuel until the chimney begins drawing, and repeat the procedure as often as necessary if the initial attempt is unsuccessful.

4. **If your Encore has been broken-in previously** using Steps 1-3, continue to build the fire gradually. Add larger wood with a diameter of 3-4" (75-100 mm). Continue adding split logs of this size to the briskly-burning fire until there is a glowing ember bed at least 3" (75 mm) deep. A good ember bed is necessary for proper functioning of the catalytic system and may take an hour or more to establish.

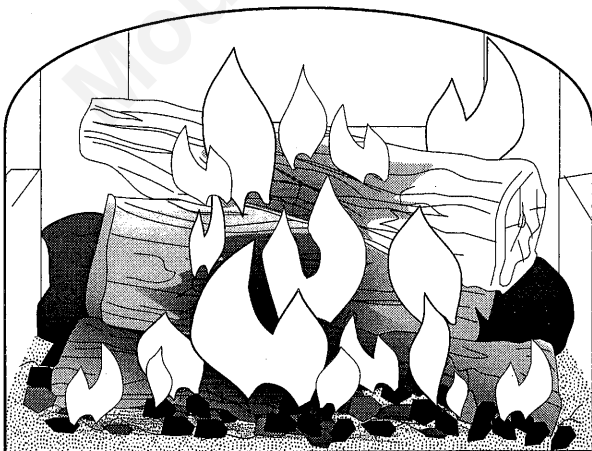

Fig. 41. Add full-size logs when the kindling has burned down to a bed of embers.

5. Close the damper when the griddle temperature reaches 450° F. (230 C).
6. Adjust the air control for your desired heat output.

NOTE: Stove installations vary, and the operating guidance given here is only a starting point. The draft management information on pages 22-23 will explain in detail how the features of your installation may help or hinder good draft.

Refuel While the Embers Are Still Hot

When reloading, best results will be achieved if you first de-ash the stove by stirring the fuel bed to allow ash to fall through the grate into the ash pan.

Do not break the charcoal into very small pieces or pound or compress the charcoal bed.

It is important that air can circulate through the charcoal bed during the burn. Larger pieces of charcoal allow more air to circulate under the wood, resulting in the fire reviving more quickly.

For best results when refueling, wear stove gloves to protect your hands, add fuel while the stove still has plenty of glowing embers to re-kindle the fire, and include some smaller pieces of wood in the new fuel load to help the stove regain its operating temperature quickly. Use this sequence as a guide to successful refueling:

1. Open the damper.
2. De-ash the stove as described above. Open the front doors and check the level of ash in the ash pan. Empty the pan if necessary and replace it in the stove. Close the front doors.
3. Open the griddle, load the wood (smaller pieces first), and close the griddle.
4. Close the damper.
5. When the surface temperature reaches 450° F. (230 C), adjust the air control for the amount of heat you desire.

NOTE: If the remaining charcoal bed is relatively thick and if your fuel is well seasoned, it is possible to add fresh fuel (smaller pieces first), close the door and damper, and reset the primary air thermostat for the desired heat output.

WARNING: OPERATE YOUR ENCORE ONLY WITH THE DOORS EITHER FULLY OPEN OR FULLY CLOSED.

CAUTION: THE ENCORE WILL BE HOT WHILE IN OPERATION. KEEP CHILDREN, CLOTHING AND FURNITURE AWAY. CONTACT MAY CAUSE SKIN BURNS.

DO NOT OVERFIRE THIS HEATER. Overfiring may cause a house fire, or can result in permanent damage to the stove and to the catalytic combustor. If any part of the Encore glows, you are overfiring.

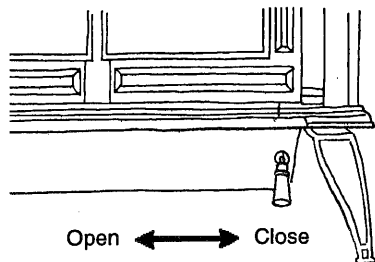

Fig. 42. Turn the handle to the ash pan compartment clockwise to open and counter-clockwise to close.

Ash Disposal

You should remove ash before it reaches the top of the ash pan. Check the level at least once a day. Every few days, clear any ash from the outer edges of the firebox.

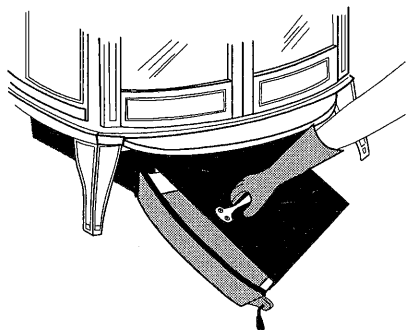

Fig. 43. Be sure the cover is securely attached before removing the ash pan.

Most of the ash will fall through the grate. Slice or stir the ash with a shovel or poker so that it falls through the grate slots.

IMPORTANT: Check the level of ash in the ash pan before reloading the stove. If the ash level is close to the top edge of the pan, empty the pan according to this procedure:

- Open the damper.
- Open the griddle or front doors, and use a shovel or poker to stir excess ash through the ash slots in the grate down into the ash pan.
- Close the griddle or doors, and unlatch the ash door. It will pivot, swinging the ash pan out of the stove.
- Slide the cover onto the pan, making sure it is securely closed. See Fig. 43.

- Remove the ash pan, making sure to keep it level. To keep the cover from sliding off and to keep ash from falling on the floor, do not tilt the ash pan forward. If the stove is in operation, close the ash door while disposing of the ash.
- Properly dispose of the ash in a metal container with a tight-fitting lid. Store the container outdoors away from all combustible material.
- Return the ash pan to its original position in the stove, and close and latch the ash door.
- Do not operate the stove with the ash door open. This will result in over-firing, and could cause damage to the stove, void the warranty, or even lead to a house fire.

Empty the ash pan regularly, typically every one to three days. The frequency will vary depending on how you operate your Encore: ash will accumulate faster at higher heat outputs.

Remove ash frequently and place it outdoors in a metal container with a tight-fitting lid. Place the closed container of ash on a noncombustible floor or on the ground, well away from all combustible materials, pending final disposal. If the ash is disposed of by burial in soil or otherwise locally dispersed, it should be kept in the closed container until all cinders have thoroughly cooled.

You can use wood ash as a garden fertilizer.

CAUTION: Never use your household or shop vacuum cleaner to remove ash from the stove; always remove and dispose of the ash properly.

DRAFT MANAGEMENT

A stove is part of a system, which includes the chimney, the operator, the fuel, and the home. The other parts of the system will affect how well the stove works. When there is a good match between all the parts, the system works well.

Wood stove or insert operation depends on natural (unforced) draft. Natural draft occurs when the smoke is hotter (and therefore lighter) than the outdoor air *at the top of the chimney*. The bigger the temperature difference, the stronger the draft. As the smoke rises from the chimney it provides suction or 'draw' that pulls air into the stove for combustion. A slow, lazy fire with the stove's air inlets fully open indicates a weak draft. A brisk fire, supported only by air entering the stove through the normal inlets, indicates a good draft. The stove's air inlets are passive; they regulate how much air *can* enter the stove, but they don't move air into it.

Depending on the features of your installation - steel or masonry chimney, inside or outside the house, matched to the stove's outlet or oversized - your system may warm up quickly, or it may take a while to warm up and operate well. With an 'airtight' stove or insert, one which restricts the amount of air getting into the firebox, the chimney must keep the smoke warm all the way to the outdoors. Some chimneys do this better than others. Here's a list of features and their effects.

Masonry chimney

Masonry is a traditional material for chimneys, but it can perform poorly when it serves an 'airtight' stove. Masonry is a very effective 'heat sink' - it absorbs a lot of heat. It can cool the smoke enough to diminish draft. The bigger the chimney, the longer it takes to warm up. It's often very difficult to warm up an outdoor masonry chimney, especially an oversized one, and keep it warm enough to maintain an adequate draft.

Steel chimney

Most factory-made steel chimneys have a layer of insulation around the inner flue. This insulation keeps the smoke warm. The insulation is less dense than masonry, so a steel chimney warms up more quickly than a masonry chimney. Steel doesn't have the good looks of masonry, but it performs much better.

Indoor / Outdoor location

Because the chimney must keep the smoke warm, it's best to locate it inside the house. This uses the house as insulation for the flue and allows some heat release into the home. An indoor chimney won't lose its heat to the outdoors, so it takes less heat from the stove to heat it up and keep it warm.

Flue sizing

The inside size of a chimney for an 'airtight' stove should match the size of the stove's flue outlet. When a chimney serves an airtight, more is not better; in fact, it can be a disadvantage. Hot gases lose heat through expansion; if we vent a stove with a six-inch flue collar (28 square inch area) into a 10 x 10" flue, the gases expand to over three times their original size. This cools the gases, which weakens draft strength. If an oversized flue is also outside the house, the heat it absorbs gets transferred to the outdoor air and the flue usually stays cool.

It's common for a masonry flue, especially one serving a fireplace, to be oversized for the stove. It can take quite a while to warm up such a flue, and the results can be disappointing. The best solution to an oversized flue is an insulated steel chimney liner, the same diameter as the stove or insert's flue outlet; the liner keeps the smoke warm, and the result is a stronger draft. An uninsulated liner is a second choice - the liner keeps the smoke restricted to its original size, but the smoke still must warm up the air around the liner. This makes the warm-up process take longer.

Pipe & chimney layout

Every turn the smoke must take as it travels to the chimney top will slow it down. The ideal pipe and chimney layout is straight up from the stove, to a completely straight chimney. If you're starting from scratch, use this layout if possible. If the stovepipe must elbow to enter a chimney, locate the thimble about midway between the stove top and the ceiling. This achieves several goals: it lets the smoke speed up before it must turn, it leaves some pipe in the room for heat transfer, and it gives you long-term flexibility for installing a different stove without relocating the thimble.

There should be no more than eight feet of single-wall stove pipe between the stove and a chimney; longer runs can cool the smoke enough to cause draft and creosote problems. Use double-wall stove pipe for long runs.

Single venting

Each 'airtight' stove requires its own flue. If an airtight stove is vented to a flue that also serves an open fireplace, or a leakier stove, it's easier for the chimney draft to pull air in through those channels than it is to pull air through the airtight, and performance suffers. Imagine a vacuum cleaner with a hole in the hose to see the effect here. In some cases the other appliance can even cause a negative draft through the airtight, and result in a dangerous draft reversal.

Creosote

Creosote is a by-product of slow wood-burning. It's an organic tar that can condense in the flue if it's dense in the smoke, and slow-moving, and cools off to less than 290 degrees F. Condensed creosote is volatile, and can generate chimney fires if it gets hot enough. All the features that affect chimney draft also affect creosote condensation - so use whatever combination of installation features and operational steps will encourage good draft and minimize creosote production.

Because letting the smoke cool off and slow down is one of the keys to creosote production, it makes sense to line a chimney to match the stove's outlet size, for safety reasons as well as performance. Canadian law *requires* a matching liner to serve any stove or insert vented through a fireplace chimney; in the US, the National Fire Protection Association recommends one if the flue is more than three times bigger (in square area) than the outlet on the stove or insert. Some localities enforce the NFPA guidelines as part of their building codes.

Fuel

Even the best stove installation will not perform well with poor fuel. The best fuel is hardwood that has air-dried 12-18 months. Softwood burns, but not as long as hardwood. Fairly 'green' wood has a good amount of moisture in it; it will burn, but some of the heat potential is used to drive the remaining moisture off the wood. This reduces the amount that reaches your home and can contribute to a creosote problem. There are moisture meters available for firewood; you can also judge your wood by its appearance and weight. If you get it green, lift a piece and get a sense of its weight; it can lose a third or more of its weight as it dries. Also look at the ends of a log; as it dries it shrinks and often cracks. The more weathered and cracked a piece is, the drier it is.

Dry wood burns readily with a good chimney draft. But with modern stoves, especially catalytic ones, the wood can be too dry. While extra-dry wood has little creosote in it, the remainder can 'gas out' from the wood quickly and densely enough to overload the catalytic burner. If you hear a rumbling or roaring noise, like a propane torch, from the stove, that is a sign that the catalyst is seriously overfiring. The catalyst is a platinum film on a ceramic base; the metal can get to higher temperatures than the ceramic can take, and overfiring the catalyst can break it. Dry wood can also burn out faster than you want. If your dry wood burns out too quickly or overloads the catalyst you can mix in greener wood to slow the fire down.

Back-puffing

Back-puffing results when the fire produces volatile gases faster than the chimney draft pulls them out of the firebox. The gases back up in the firebox till they're dense enough and hot enough to ignite. If your stove back-puffs, you should open up the damper to let the smoke rise to the flue more quickly, let more air into the firebox, and avoid big loads of firewood. You should always see lively, dancing flames in the firebox; a lazy, smoky fire is inefficient, can lead to back-puffing, and can contribute to creosote buildup in the chimney.

Draft testing

An easy way to test your chimney draft is to close the stove's damper, wait a few minutes to let the airflow stabilize, then see whether you can vary the strength of the fire by swinging the air control open and closed. Results are not always instant; you may need to wait a few minutes for a change in the air control setting to have an effect on the fire. If there's no change, then the draft isn't strong enough yet to let you close the damper, and you'll need to open it for a while longer and manage the fire with the air inlet until the draft strengthens. If you keep track of your burning habits and relate them to their effects on the stove's operation, you'll be rewarded with good performance and a safe system.

Negative pressure

Good draft also depends on a supply of air to the stove; a chimney can't pull in more air than is available to it. Sluggish draft results when a house is tight enough to prevent the ready flow of air to the stove, or by competition between the stove and other equipment that sends indoor air outside - especially power-driven equipment like range hoods, clothes dryers, etc. If the chimney draws well with all other equipment turned off (or sealed, in the case of fireplaces and/or other stoves), then you simply need to be careful with timing the use of the other gear. If you need to crack a nearby window or door to enable the chimney to pull well, that's a sign that you should install an outside-air intake to bring combustion air directly to the stove. For most of our stoves we carry adapters to attach to the stove to connect an air duct for outdoor combustion air.

Conclusion

Wood-burning is an art rather than a science. Once the stove and chimney system are in place, you can only vary your technique, mostly your timing, to achieve good results. If you keep track of your burning habits and relate them to their effects on the stove's operation, you'll be rewarded with good performance and a safe system.

Maintenance

Keep Your Stove Looking New and Working Its Best

Let the fire in the stove go out and allow the stove to cool completely before beginning any maintenance procedure.

Care of the Cast Iron Surface

An occasional dusting with a dry rag will keep the painted cast iron of your Encore looking new.

The stove's paint can be touched up as needed. First, mask the areas, such as enamelled parts, glass, or handles, around the spot to be painted. Clean the spot with a wire brush. Remove the griddle and set it aside.

Then, touch up the stove with Vermont Castings' high temperature stove paint. Apply the paint sparingly; two light coats of paint are better than a single heavy one.

Care of the Porcelain Enamel Surface

Use a dry or slightly damp rag or soft brush to remove spills or stains. For difficult jobs that require a cleaning agent, use only a kitchen appliance cleaner or polish recommended for use on enamel surfaces.

Cleaning the Glass

Most of the carbon deposits on the glass will burn off during hot fires.

However, the ash residue that accumulates on the glass surface should be removed regularly to prevent etching. To clean the glass, follow this procedure:

- Be sure the glass is completely cool.
- Clean the glass with water or a cleaner made especially for this purpose. Do not use abrasive cleaners.
- Rinse the glass thoroughly.
- Dry the glass completely.

Replace Broken Glass Immediately

Do not operate your stove if the glass in the doors is damaged.

If you need to replace the glass, use only the high temperature ceramic glass supplied by Vermont Castings. Do not use substitutes. Be sure to specify left or right glass; the panels are not interchangeable.

Removing the Glass

The left door is slightly different from the right in that one of its retainer clips is located under the door manifold.

1. Remove the right and left door assemblies by raising the door until the lower hinge pin clears its drilling; then, angle the door bottom slightly outward and pull down to release the upper hinge pin. Place the doors face down on a padded work surface.

2. Remove the screws that hold the retainer clips in place, and remove the clips. On the right door, remove the Phillips head machine screw that secures the door manifold to the upper right of the door (as it faces you). Swing the door manifold out of your way and remove the clip beneath it as well.
3. Carefully lift the broken glass panel from the door.

Installing the Glass

Check the gasket around the window; it should be soft and resilient so that the glass will seal properly against the door. Replace the gasket if it has hardened or if it is compressed.

1. Center the first pane of glass on the gasket. Be sure to place the glass so that the infrared reflective coating is on the exterior side.

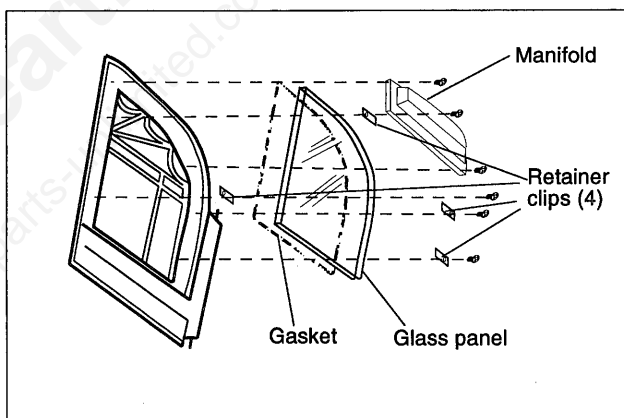

Fig. 44. An exploded view of the glass assembly on the left door.

2. Secure the glass on both doors with the retainer clips except the one that belongs under the manifold of the right door, but leave the screws a little loose.

Position the remaining clip under the right door manifold, and then swing the manifold back into position on the door. Make sure that the screw passing through the end of the manifold nearest the center of the door also passes through the retainer clip.

3. Replace the doors on the stove. Remove the griddle so you can reach in through the opening to position the manifold. Move the door manifold as high as possible without actually touching the upper air manifold, and as far toward the center of the stove as possible without hitting the door manifold on the other door. Tighten all screws.
4. Open and close the doors to check that the door manifold does not interfere with either of the other manifolds. Adjust as necessary.

Check the Operation of the Primary Air Shutter

The primary air shutter is located at the back of the ash drop and is visible from the back of the stove, as in Fig. 45. The shutter must open and close freely when you move the thermostat lever. If it doesn't, remove any obstruction. If you need assistance, consult your local Vermont Castings Authorized Dealer.

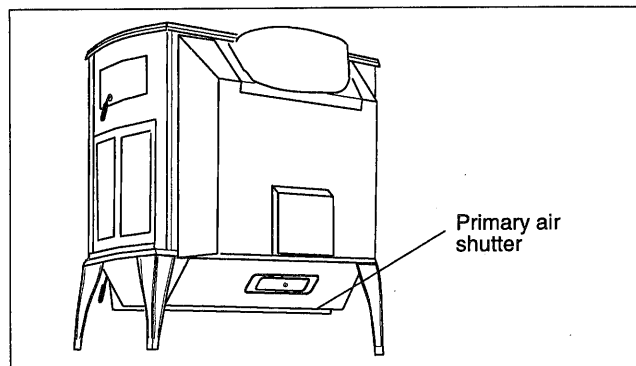

Fig. 45. The primary air shutter must move freely.

Do not change the adjustment of the cable in an attempt to gain increased firing. The air shutter controls how much air can enter the stove, but it is chimney draft is the force that pulls air into the stove. If changing the thermostat handle position does not lead to changes in the fire's intensity, it's probably due to weak chimney draft (in the case of a weak fire you can't increase) or an air leak in the stove (in the case of a fire you can't decrease).

Adjust the Damper as Needed

The tension on the Encore's damper is adjustable to compensate for compression of the gasket that seals the damper to the upper fireback. To adjust the damper:

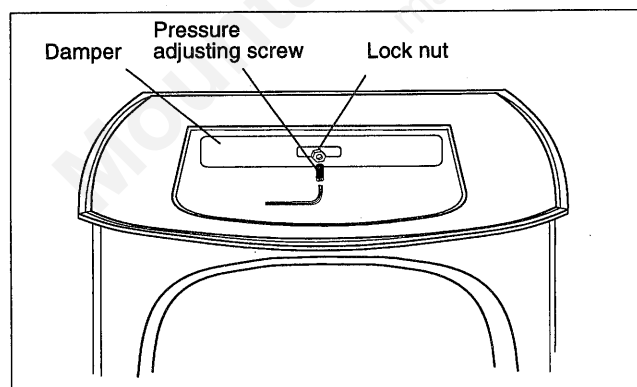

Fig. 46. Adjusting the damper.

1. Remove the griddle. Loosen the lock nut at the center of the damper.
2. Turn the pressure screw approximately one half turn clockwise.
3. Tighten the lock nut. Keep the pressure screw from turning as you tighten the nut. Re-test the damper.

Tighten the Damper Handle as Needed

A handle on the left side of the stove controls the damper. The handle attaches to the damper rod with a set screw. Periodically check the set screw and tighten as necessary.

How to Adjust the Door Latches

The Encore's front doors, as well as its ash pan door, should close securely to prevent accidental opening and to keep air from leaking into the stove. On adequately adjusted doors, the handles should resist slightly as they are turned to the closed position and the doors themselves should be drawn slightly toward the stove.

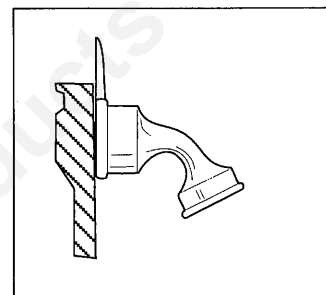

Fig. 47. A section through the front door latch.

Over time, the gasket around the doors will compress and the latch may need adjustment.

To adjust the handle on the front doors, open the door on which the handle is mounted and rotate the handle one full turn counterclockwise. Since this handle is threaded into the front door, a complete revolution will adjust it enough so that the doors close securely.

To adjust the latch on the ash pan door, loosen the small lock nut, rotate the striker screw a half-turn, and re-tighten the small lock. Hold the striker screw to keep it from turning as you tighten the lock nut. Make repeated small adjustments until the setting is right.

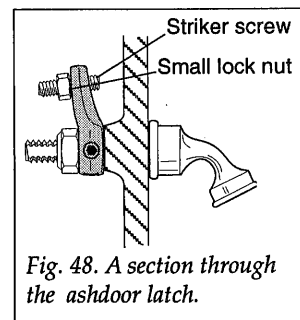

Fig. 48. A section through the ash door latch.

The Catalytic Element

Inspection and Cleaning

This wood heater contains a catalytic combustor, which needs periodic inspection and replacement for proper operation. In The United States it is against the law to operate this wood heater in a manner inconsistent with the operating instructions in this manual, or if the catalytic element is deactivated or removed.

Under normal operating conditions, the catalytic combustor should remain active for two to six years (depending on the amount of wood burned). However, it is important to monitor the combustor periodically to ensure that it is functioning properly, as well as to determine when it needs to be replaced. A non-functioning combustor will result in a loss of heating efficiency, and an increase in creosote and emissions.

Inspect the combustor "in place" for fly ash accumulation and physical damage three times per year. Do not remove the combustor unless a more detailed inspection is warranted because of diminished performance as outlined below.

The refractory package that houses the catalytic combustor should be inspected annually for a buildup of fly ash and cleaned if necessary. This may be done when you examine the combustor.

When To Suspect a Combustor Problem

The best way to evaluate the performance of your Encore's combustor is to observe the amount of smoke leaving the chimney — both when the combustor has achieved "light-off" and when it has not. Follow these steps:

- With a fire going and the combustor properly activated, with the damper closed to route smoke through it as described in the Operation Section, go outside and observe the smoke leaving the chimney.
- Then, open the stove damper and once again check the smoke leaving the chimney.

Significantly more smoke should be seen when the stove damper is open and exhaust does not pass through the combustor. Be careful not to confuse smoke with steam from wet wood, however. Steam dissipates in the air quickly; smoke does not.

If this test indicates a problem, consider other possible factors as well, such as the time of year or a change in the quality of your fuel. In spring and fall, draft is weaker than it is in colder winter weather, and fires can burn sluggishly. Small, hot fires are a good solution under these conditions.

Burning "green" (insufficiently seasoned) wood will result in poorer performance than when burning properly seasoned fuel. You may have to run your stove hotter (more air) to achieve good performance with green or wet wood.

Also, consider any changes in your operating routine.

Once you have ruled out any other possible causes for a decline in performance, you may inspect the combustor.

Inspecting the Combustor

1. Release the hood from the fireback by swinging the hood upward and then sliding it to either side, as in Fig. 49.

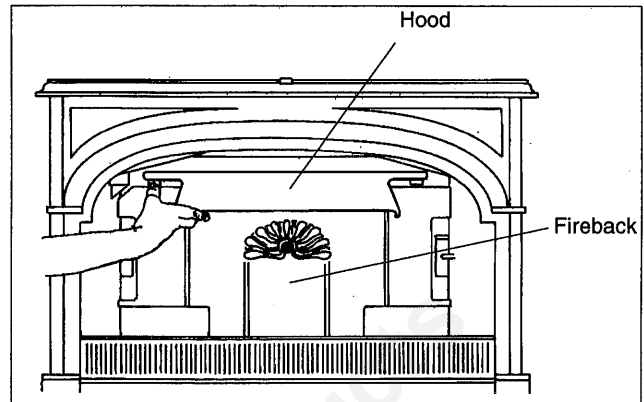

Fig. 49. Release the hood by lifting its bottom edge and sliding it to one side.

2. Using a flashlight, and a mirror if necessary, examine the combustor. If no fly ash or damage is visible, the inspection is complete and you may replace the hood. If further examination or cleaning is necessary, go to Step 3.

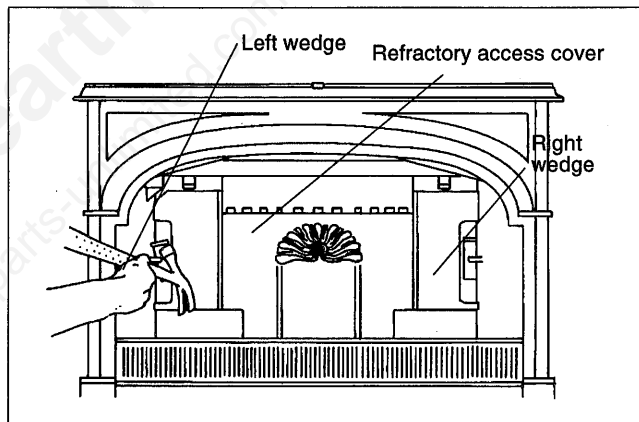

Fig. 50. Release the lower fireback by tapping out two wedges.

3. Release the fireback by prying the left and right wedges upward as shown in Fig. 50.
4. Swing the fireback forward and up to remove it from the stove, as shown in Fig. 51.

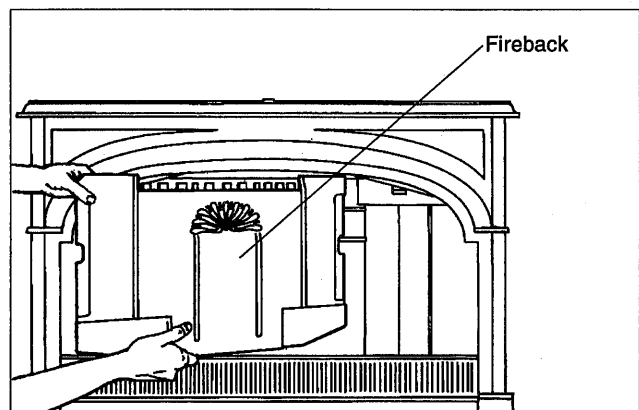

Fig. 51. Remove the lower fireback through the front door opening.

5. Remove the catalytic combustor's refractory access cover, then remove the combustor.
6. Check the combustor's honeycomb-like element for a buildup of fly ash. If any is evident, take the combustor outside and clean it by blowing air gently through it.
7. Inspect the element for damage or degradation. Although small hairline cracks will not affect performance, the element should be essentially intact. If the element is broken in pieces or has sections missing, it should be replaced. Call your local Vermont Castings' Authorized Dealer for a replacement element.

While the catalytic element is removed, check the condition of the secondary air probe. Use an inspection mirror to locate the probe within the combustion chamber. The probe should extend 1" to 1-1/2" into the chamber and show no signs of deterioration, such as warping, corrosion, or short length. Refer to Figure 52. A damaged secondary air probe can affect catalytic performance. If the probe needs replacement, contact your local dealer.

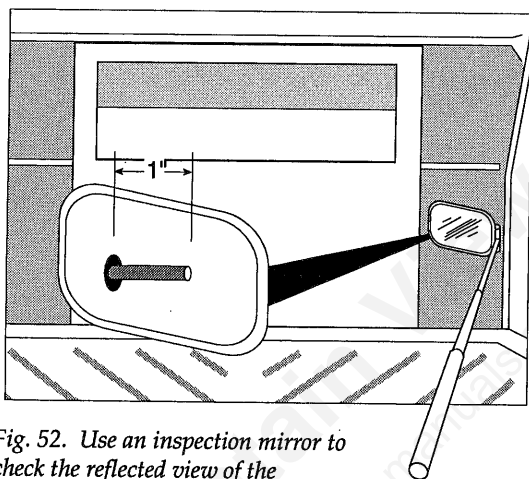

Fig. 52. Use an inspection mirror to check the reflected view of the secondary probe.

8. If the element is in good condition and clean, re-install it in the stove and replace the refractory access cover.
9. Replace the fireback, install the two wedges, and replace the cast iron hood.
10. Clean the chimney and chimney connector.

Operate the stove in your typical manner for two weeks, inspecting the chimney and the chimney connector frequently during this period.

If creosote is not building up as fast, it is likely that the performance change was caused by fly ash deposits on the catalytic element. However, continue the inspections of the chimney system for a few weeks to ensure that proper performance continues.

If you continue to find a significant creosote buildup or if you continue to see excessive smoke from the chimney, the catalytic element will need to be replaced. Contact your nearest Vermont Castings' Authorized Dealer for information about a replacement element.

NOTE: Use only the replacement catalyst supplied by a Vermont Castings dealer.

Replace the Stove Gaskets as Needed

Your Encore uses rope-type fiberglass gaskets to make a tight seal between some parts. With use, particularly on those parts that move, gaskets can become brittle and compressed and can begin to lose their effectiveness. These will need periodic replacement.

All of the gaskets are made of fiberglass. The sizes of replaceable gasket are listed below, along with their applications.

Gasket Diameter...	...And the Parts it Seals
5/16"	The griddle to the stove top (wire reinforced gasket)
3/8"	The ash door to the front of the ash drop
3/16"	The outer glass panes to the doors
5/16"	The damper to the upper fireback; the front doors to the stove front; and the doors to each other.

If you need to change a gasket, first obtain an appropriate replacement from your Vermont Castings' Authorized Dealer.

Wait until the fire is out and the stove has cooled. Be sure to follow the standard safety procedure for working with dusty materials: Wear safety goggles and a dust mask.

The procedure for replacing gaskets is the same, regardless of the gasket location. Follow these steps:

1. Remove the existing gasket by grasping an end and pulling firmly.

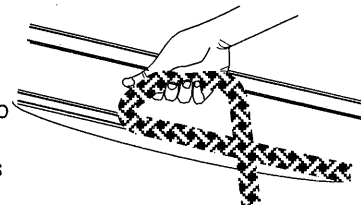

Fig. 53. Remove the old gasket.

2. Use a wire brush or the tip of a screwdriver to clean the channel of any remaining cement or bits of gasket, as in Fig. 54. Remove stubborn deposits of cement with a cold chisel if necessary.

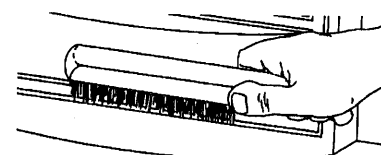

Fig. 54. Clean the gasket channel with a wire brush.

3. Determine the correct length of the appropriate-sized gasket by laying it out in the channel. Allow an extra 1-2" (25-50 mm), and mark the spot to be cut. See Fig. 55.

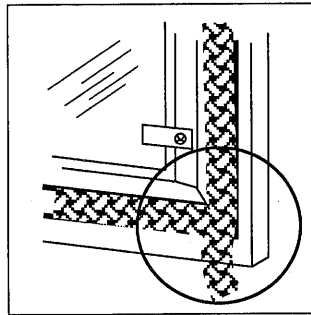

Fig. 55. Lay out the gasket in its channel to determine the right length.

4. Remove the gasket from the channel, place it on a wood cutting surface, and cut it at the marked spot with a utility knife.

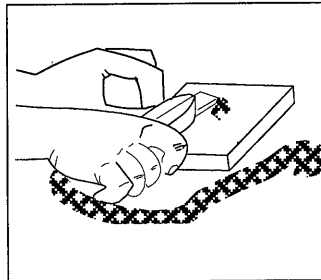

Fig. 56. Cut the gasket to rough length.

Twist the ends slightly to keep the gasket from unraveling.

5. Lay an unbroken 1/8" (3 mm) bead of gasket cement in the newly-cleaned channel.

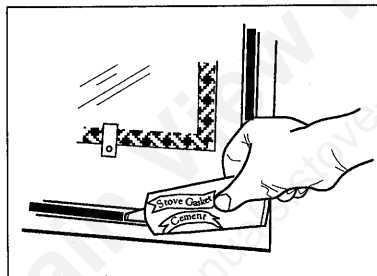

Fig. 57. Apply new cement to the clean channel.

6. Starting at one end, press the gasket into the channel. Ensure a good joint where the gasket meets before trimming any excess. Do not overlap the gasket ends or leave ends with ragged edges.

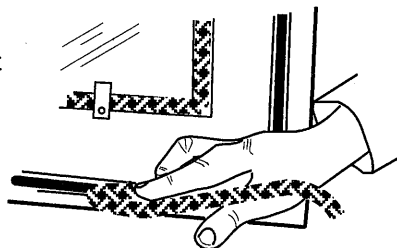

Fig. 58. Apply new gasket to the channel.

7. Press the gasketed part firmly against its normal mating surface to seat the gasket evenly in its channel. Close and latch the door to do this, or tap other parts with the rubber mallet (or hammer/block of wood).

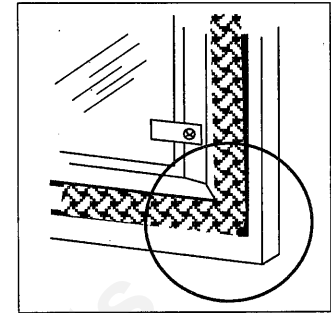

Fig. 59. Seat the gasket in its channel.

8. Clean any excess cement from around the channel, then let the cement that holds the new gasket dry thoroughly.

Adjust the Door If Necessary

The stove's door(s) may need adjustment after you have regasketed it. Initially, it may require loosening to accommodate the new gasket; after a few weeks, it may need tightening to compensate for compression of the new gasket. The directions for adjusting the doors are on page 23-24

Permanent Encore Gaskets

Other gaskets form seals between non-moving parts, but these are not subject to the same wear and deterioration as gaskets on moving parts. It is unlikely that you will ever need to replace these gaskets unless the involved parts are disassembled and then put back together. If this is the case, the job should be done only by a qualified service technician.

5/16" diameter gasket seals the following parts:

- The flue collar to the stove back
- The lower fireback to the sides

The Chimney System

Creosote

Your Encore is designed to reduce creosote build-up significantly. However, regular chimney inspection and maintenance must still be performed. For safety, good stove performance, and to protect your chimney and chimney connector, inspect your chimney and chimney connector on a regular schedule. Clean the system if necessary. Failure to keep the chimney and connector system clean can result in a serious chimney fire.

When wood is burned slowly, it produces tar, organic vapors and moisture that combine to form creosote. The creosote vapors condense in the relatively cool chimney flue of a slow-burning fire. As a result, creosote residue accumulates on the flue lining. When ignited, this creosote makes an extremely hot fire within the flue system that can damage the chimney and overheat adjacent combustible material. If a significant layer of creosote has accumulated —1/8" (3 mm) or more — it should be removed to reduce the risk of a chimney fire.

If you do experience a chimney fire, act promptly to:

- Close the damper and thermostat lever.
- Get everyone out of the house.
- Call the Fire Department.

You should inspect the system every two weeks during the heating season as part of a regular maintenance schedule. To inspect the chimney, let the stove cool completely. Then, using a strong light, sight up through the flue collar into the chimney flue. If it is not possible to inspect the flue system in this fashion, the stove must be disconnected to provide better viewing access.

Clean the chimney using a brush the same size and shape as the flue liner. Flexible fiberglass rods are used to run the brush up and down the liner, causing any deposits to fall to the bottom of the chimney where they can be removed through the clean-out door.

Clean the chimney connector by disconnecting the sections, taking them outside, and removing any deposits with a stiff wire brush. Reinstall the connector sections after cleaning, being sure to secure the joints between individual sections with sheet metal screws.

If you cannot inspect or clean the chimney yourself, contact your local Vermont Castings' Dealer or a professional chimney sweep.

Annual Maintenance

Every Spring, at the end of the heating season, perform a thorough cleaning, inspection and repair:

- Thoroughly clean the chimney and chimney connector.
- Inspect the chimney for damage and deterioration.
 - Replace weak sections of prefabricated chimney.
 - Have a mason make repairs to a masonry chimney.
- Inspect the chimney connector and replace any damaged sections.
- Check gasketing for wear or compression, and replace if necessary.
- Inspect and clean the catalytic element, and vacuum out the ash at the bottom of the back plate after removing the lower fireback. Lightly clean the refractory assembly that houses the element but be careful not to damage the refractory material, which is very fragile.
- Check door and damper handles for tightness. Adjust if needed.
- Check heat shield screws. Tighten as necessary.
- Clean dust from the inner sides of bottom, rear and connector heat shields.
- Remove ashes from the ash pan and replace with moisture absorbing material (such as cat litter) to keep the stove interior dry.
- Touch up the paint on black stoves.

Appendix: Catalytic Combustor

In any chemical reaction, including the combustion process, there are certain conditions which must be met before the reaction can take place. For example, a reaction may require a certain temperature, or a certain concentration of the reactants (the combustion gases and oxygen), or a certain amount of time. Catalysts, though not changed themselves during the reaction, have the ability to act at a molecular level to change these requirements. In the Encore's secondary combustion chamber the catalyst reduces the temperature at which secondary combustion can start from the 1000 - 1200° F. (540 - 650° C) range to the 500 - 600° F. (260 - 315° C) range, increasing efficiency, and reducing creosote and emissions.

The catalytic reaction does have some limitations of its own. Primary among these is that the reactants (the gases) come into close physical contact with the catalyst itself.

To ensure the necessary contact, the catalytic element in your Encore is composed of a ceramic base in the shape of a honeycomb. Each of the honeycomb's many surfaces carries a coating of the catalyst (usually a noble metal such as platinum or palladium). The large surface area exposed in this form ensures that the combustion gases have the greatest opportunity to come in contact with the catalyst.

Loss of catalytic activity will be apparent in several ways. First you may notice an increase in fuel consumption. Second, there will be a visible increase in the rate at which creosote builds up in your chimney connector system. You may also notice a heavy discharge of smoke from the chimney. There are a number of catalytic problems which can cause loss of activity:

Blockage

While the honeycomb pattern ensures good contact, it also increases the resistance to flow of the combustion gases, and, because of the many surfaces, provides more places for creosote and fly ash to deposit. It is important to follow the operating instructions in order to minimize these deposits, and to periodically inspect your catalyst for signs of blockage.

Masking and Poisoning

While the catalyst itself does not enter into the combustion process, certain elements, such as lead and sulfur, can attach to the active sites on the surface of the honeycomb. Though the catalyst is still there, it is covered, or masked, by the contaminant, and cannot function. To avoid this situation, it is important not to burn anything in your Encore that is a source of these contaminants. Particularly avoid painted or treated wood, coal, household trash, colored papers, metal foils, or plastics. Chemical chimney cleaners may also contain harmful elements. The safest approach is to burn only untreated, natural wood.

Flame Impingement

The catalytic element is not designed for exposure to direct flame. If you continually overfire your Encore, the chemistry of the catalyst coating may be altered, inhibiting the combustion process.

Thermal degradation of the ceramic base may also occur, causing the element to disintegrate. Stay within the recommended guidelines of the Operation section.

Mechanical Damage

If the element is mishandled, damage may occur. Always treat the element carefully. Remember the catalyst is made of a ceramic material; treat it as you would fine china. Hairline cracks will not affect the performance of the catalyst, as long as the steel sleeve holds the element in the proper position.

Peeling

The surface coat may peel if the catalytic element is frequently subjected to excessive temperatures. Follow the operating instructions carefully to avoid this type of damage.

General

Every Vermont Castings' Encore is equipped with either a Corning "Long-Life"® or a Technical Glass Products "Honeycomb"® combustor. The products are equivalent.

If you must ship your catalytic element for any reason, remember its fragile nature. Place the element in a plastic bag, and package it with a generous amount of shock absorbing material.

Warranty

Limited 3 Year Warranty

Vermont Castings, Inc. warrants that this Encore will be free of defects in material and workmanship for a period of three years from the date you receive it, except that the catalyst, thermostat assembly, handles, glass door panels, cement, and gasketing shall be warranted as described below.

Vermont Castings, Inc. will repair or replace, at its option, any part found to be defective when the Encore is returned with shipping charges prepaid to a Vermont Castings Authorized Dealer. The customer must pay for any Authorized Dealer in-home travel fees, service charges, or transportation costs for returning the stove to the Authorized Dealer. It is the dealer's option whether the repair will be done in the customer's home or in the dealer's shop. If upon inspection the damage is found to be the fault of the manufacturer, repairs will be authorized at no charge to the customer for parts and/or labor.

Any Encore or part thereof that is repaired or replaced during the limited warranty period will be warranted under the terms of the limited warranty for a period not to exceed the remaining term of the original limited warranty or six (6) months, whichever is longer.

Limited 1 Year Warranty

The following parts of the Encore are warranted to be free of defects in material and workmanship for a period of one year from the date you receive it: The thermostat assembly, handles, glass door panels, cement, and gasketing. Any of these items found to be defective will be repaired or replaced at no charge, upon the return of the part with postage prepaid to a Vermont Castings Authorized Dealer.

Any part repaired or replaced during the limited warranty period will be warranted under the terms of the limited warranty for a period not to exceed the remaining term of the original limited warranty or six (6) months, whichever is longer.

Limited Catalyst Warranty

The catalyst will be warranted for a six year period as follows: If the original catalyst or a replacement catalyst proves defective or ceases to maintain 70% of its particulate emission reduction activity (as measured by an approved testing procedure) within 24 months from the date the Encore is received, the catalyst itself will be replaced free.

From 25 - 72 months a pro-rated credit will be allowed against a replacement catalyst and the cost of labor necessary for its installation at the time of replacement.

For stove purchases made after June 30, 1990, a third year (25 - 36 months) of no charge replacement will be made when combustor failure is due to thermal degradation of the substrate (crumbling of ceramic material). The customer must pay for any in-home travel fees, service charges, or transportation costs for returning the Encore to the Authorized Dealer.

Amount of Time Since Purchase	Credit Towards Replacement Cost
0 - 24 months	100%
25 - 36 months	50 %
37 - 48 months	30%
49 - 60 months	20%
61 - 72 months	10%

Any replacement catalyst will be warranted under the terms of the catalyst warranty for the remaining term of the original warranty. The purchaser must provide the following information in order to receive a replacement catalyst under the terms of this limited warranty:

1. Name, address and telephone number.
2. Proof of original purchase date.
3. Date of failure of catalyst.
4. Any relevant information or circumstances regarding determination of failure.
5. In addition, the owner must return the failed catalyst.

Exclusions & Limitations

1. This warranty is transferable; however, proof of original retail purchase is required.

2. This warranty does not cover misuse of the Encore. Misuse includes overfiring which will result if the Encore is used in such a manner as to cause one or more of the plates to glow red. Overfiring can be identified later by warped plates and areas where the paint pigment has burned off. Overfiring in enamel fireplaces is identified by bubbling, cracking, chipping and discoloration of the porcelain enamel finish. Vermont Castings offers no warranty on chipping of enamel surfaces. Inspect your Encore prior to accepting it for any damage to the enamel.

3. This warranty does not cover misuse of the Encore as described in the Owner's Guide, nor does it cover an Encore which has been modified unless authorized by a Vermont Castings representative in writing. This warranty does not cover damage to the Encore caused by burning salt saturated wood, chemically treated wood, or any fuel not recommended in the Owner's Guide.

4. This warranty does not cover an Encore repaired by someone other than a Vermont Castings Authorized Dealer.

5. Damage to the unit while in transit is not covered by this warranty but is subject to a claim against the common carrier. Contact the Vermont Castings Authorized Dealer from whom you purchased your Encore or Vermont Castings if the purchase was direct. (Do not operate the Encore as this may negate the ability to process the claim with the carrier.)

6. Claims are not valid where the installation does not conform to local building and fire codes or, in their absence, to the recommendations in our Owner's Guide.

7. Vermont Castings shall have no obligation to enhance or update any unit once manufactured.

8. The salt air environment of coastal areas, or high-humidity environment, can corrosive to the porcelain enamel finish. These conditions can cause rusting of the cast iron beneath the porcelain enamel finish, which will cause the porcelain enamel finish to flake off. This warranty does not cover damage caused by a salt air or high-humidity environment.

IN NO EVENT SHALL VERMONT CASTINGS BE LIABLE FOR INCIDENTAL AND CONSEQUENTIAL DAMAGES. ALL IMPLIED WARRANTIES INCLUDING THE IMPLIED WARRANTIES OF MERCHANTABILITY AND FITNESS, ARE LIMITED TO THE DURATION OF THIS WRITTEN WARRANTY. THIS WARRANTY SUPERSEDES ALL OTHER ORAL OR WRITTEN WARRANTIES.

Some states do not allow the exclusion or limitations of incidental and consequential damages or limitations on how long an implied warranty lasts, so the above limitations may not apply to you. This warranty gives you specific rights and you may have other rights which vary from state to state.

How to Obtain Service

If a defect is noted within the warranty period, the customer should contact a Vermont Castings Authorized Dealer or Vermont Castings if the purchase was direct with the following information:

1. Name, address, and telephone number of the purchaser.
2. Date of purchase.
3. Serial number from the label on the back.
4. Nature of the defect or damage.
5. Any relevant information or circumstances, e.g., installation, mode of operation when defect was noted.

A warranty claim process will then start. Vermont Castings reserves the right to withhold final approval of a warranty claim pending a visual inspection of the defect by authorized representatives.

Parts Diagram for the 1997- Model 2550 Encore

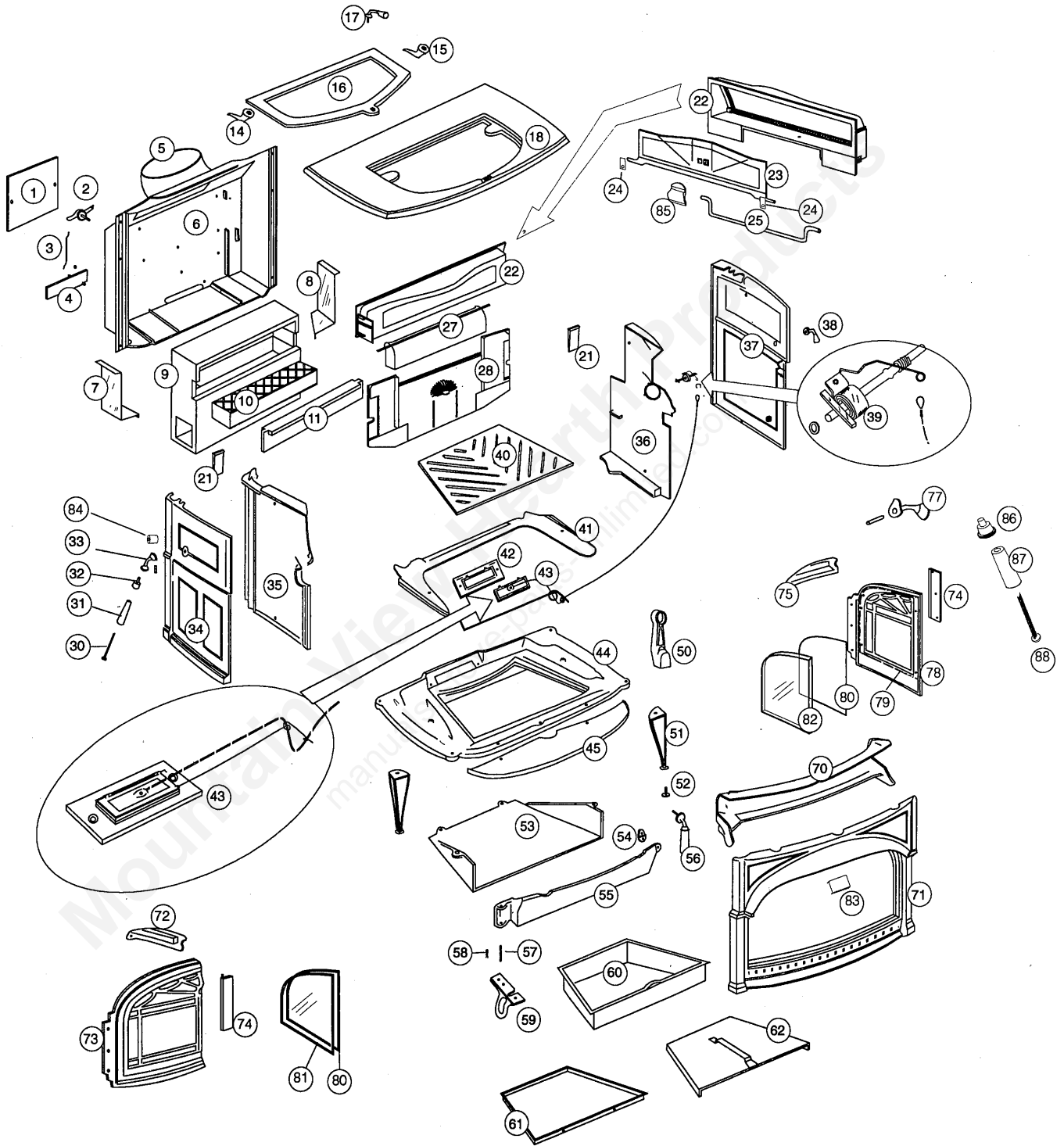

Parts List for the Model 2550 Encore

1	Secondary air cover plate	160-1492	42	Primary air frame	130-7411
2	Secondary air probe assembly	160-1489	43	Primary air regulatory system	500-0337
3	Secondary air link	160-1486	44	Bottom	130-8604
4	Secondary air flap	160-1490	45	Ashlip	130-7406
5	Flue collar (8")	130-4280	50	Andiron (2)	130-7419
6	Back	130-8620	51	Leg	130-7427
7	Left heat deflector	160-8629	52	Leg leveler	120-1745
8	Right heat deflector	160-8630	55	Ashdoor	130-8607
9	Refractory assembly (body only)	160-2512	53	Ashdrop	130-8603
10	Catalytic combustor	160-2505	54	Ashdoor latch pawl	130-0515
11	Refractory access panel	160-2511	56	Ashdoor handle (wood)	160-0663
14	Left griddle quad	130-1807	57	Ashdoor hinge pin	120-8608
15	Right griddle quad	130-1832	58	Cotter pin	120-3029
16	Griddle	130-0797	59	Ashdoor hinge support	130-8605
17	Griddle handle assembly	500-4022	60	Ashpan	160-1025
18	Top	130-8618	61	Ashpan bracket	160-1039
21	Wedge (2)	130-1810	62	Ashpan cover	160-1027
22	Upper fireback ¹	130-8644	70	Airwash manifold	130-8615
23	Damper ¹	130-8631	71	Front	130-8635
24	Damper tabs (3) ¹	160-1488	72	Left door air manifold	130-7403
25	Damper rod ¹	160-0851	73	Left door	130-8637
27	Combustion throat hood	130-1145	74	Door hinge strip (2)	130-8634
28	Lower fireback	130-8646	75	Right door air manifold	130-7404
30	Damper handle screw	120-1294	77	Front door catch	500-4225
31	Damper handle	160-0620	78	Right door	130-8636
32	Handle insert	160-0650	79	Door gasket	120-3588
33	Steel handle stub	160-0608	80	Glass gasket	120-3516
34	Left side	130-8623	81	Left door glass ²	140-8630
35	Left air plate (inner side)	130-8621	82	Right door glass ²	140-8629
36	Right air plate (inner side)	130-8622	83	Door latch	140-8628
37	Right side	130-8619	84	Spacer	120-1779
38	Thermostat handle assembly	500-4264	85	Damper ramp ¹	130-1811
39	Thermostat assembly	500-5470	86	Handle base stub ³	160-0650
40	Grate	130-7434	87	Ceramic handle ³	160-0620
41	Primary air tube cover plate	130-8609	88	Handle bolt ³	120-1294

1. Included in #500-8649 upper fireback assembly.
2. Not interchangeable, due to a heat-reflective coating on the room side of the panels.
3. Included in #000-4342 ceramic handle assembly.

Notes:

In this diagram and throughout this manual, 'left' and 'right' mean *as you face the stove*.

When ordering parts, be sure to mention the stove's model number. When ordering external parts for an enamelled stove, be sure to specify color.

The hardware in the Encore is in standard sizes; most bolts are 1/4" diameter by 20 threads per inch. Any hardware store can supply replacement hardware if you specify bolt diameter, number of threads per inch, and length.

To learn the name of the dealer nearest you, call or write:
 The Majestic Products Co.
 1000 E. Market St.
 Huntington, IN. 46750-2579
 219-356-8000