



Encore 2N1

Non-Catalytic / Catalytic

Woodburning Stove Model 2040

Service Manual

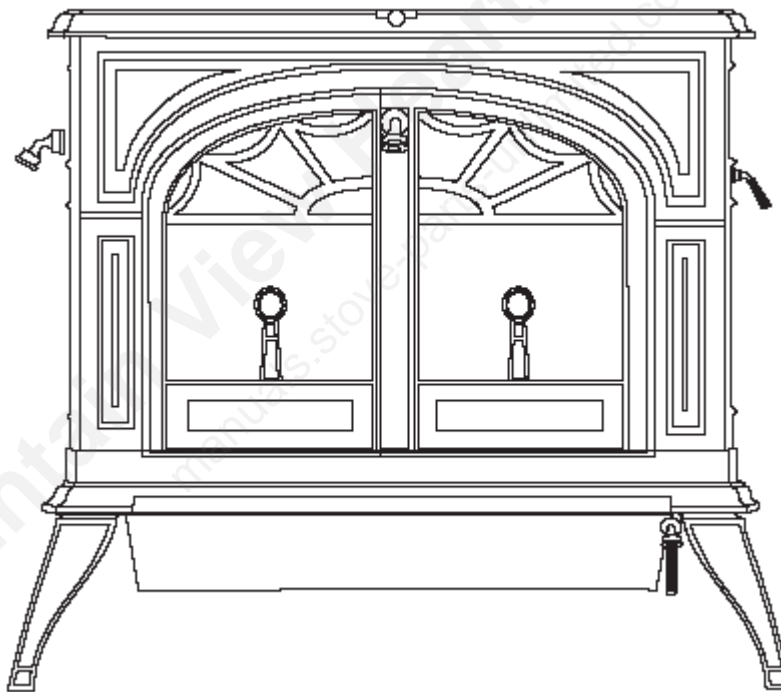

Contents:

Parts, Gaskets and Hardware Listings

Service Procedures: Replace Top; Replace Interior Rear Component; Adjust Doors; Adjust Door Roller Pawl;

Complete Tear Down

Gasket Layout

Suggested Maintenance

Encore 2N1 Parts List

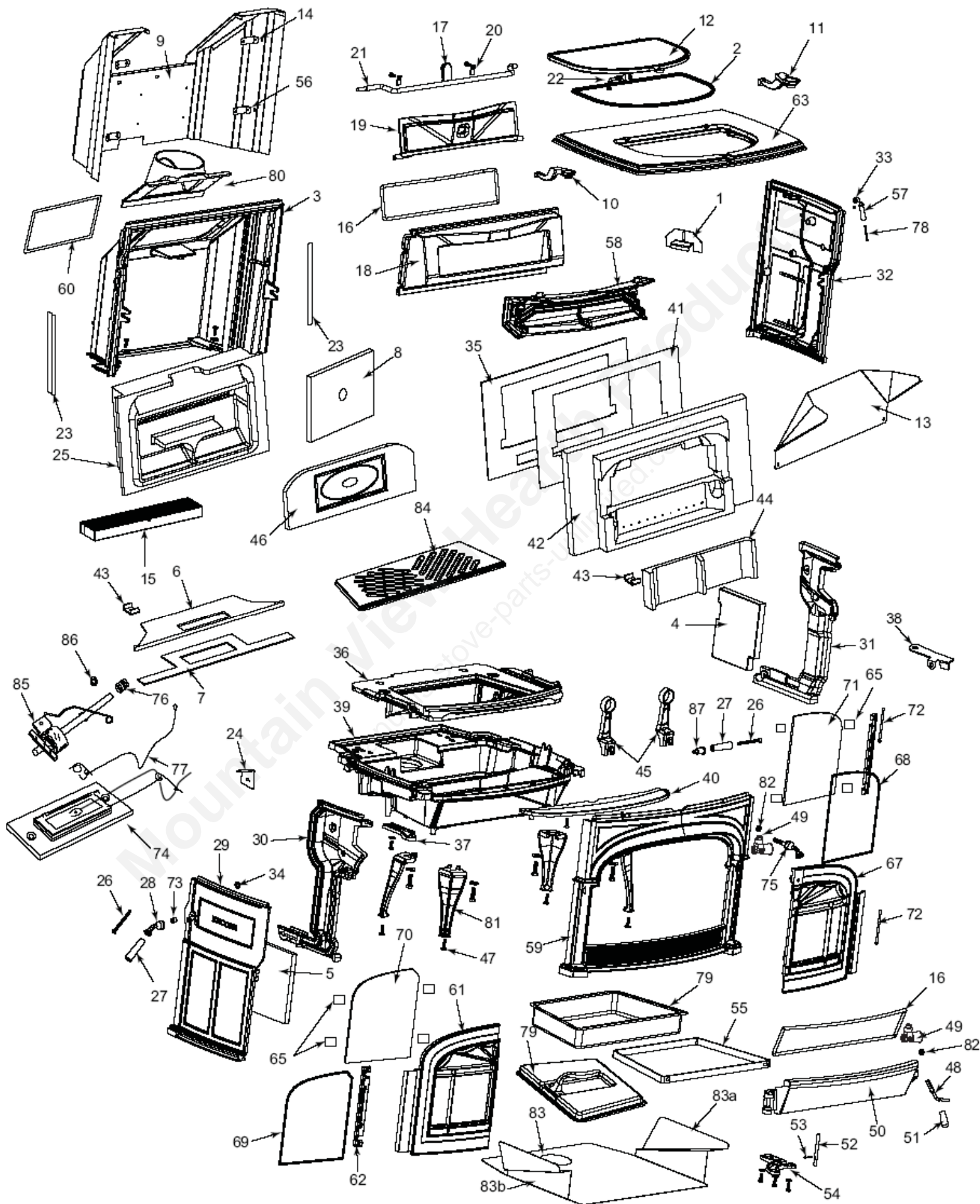

Encore 2N1 Parts List Continued.....

Item Description	Part Number
1. Brick Support Bracket	30005279
2. Griddle Gasket	1203668
3. Back	30005289
4. Refractory Rt End	30002421
5. Refractory Lt End	30002475
6. Refractory Support	30005233
7. Gasket, Fiber, Refractory Support	30005237
8. Back Insulation Board	30005269
9. Outer Back	30005261
10. Left Griddle Quadrant	30002399
11. Right Griddle Quadrant	30002401
12. Griddle	30002386
13. HS Flue Collar	30005266
14. Bracket Upper Side	30005267
15. Catalyst, Ceramic	30005353
16. Damper Ashdoor Gasket	1203588
17. Damper Ramp	1301811
18. Damper Housing	30005293
19. Damper ¹	30002389
20. Damper Tab ¹	1601488
21. Damper Rod ¹	1600851
22. Griddle Handle Assy	30002775
23. Gasket, Fiber Back Refractory	30005270
24. Rheostat Bracket	30002863
25. Refractory, Engine - E/D	30005202
26. Damper Handle Screw	1201310
27. Damper Handle	1600664
28. Damper Handle w/Screw Assy	30002720
29. Left Side	See Chart Below
30. Left Air Manifold	30002408
31. Right Air Manifold	30005290
32. Right Side	See Chart Below
33. Thermostat Handle Base Assy	30002716
34. Washer Damper Rod	1202560
35. Fireback Plate, S/S	30005217
36. Inner Bottom	30005291
37. Ashdoor Hinge Upper	30002403
38. Door Handle Bracket	30002909
39. Bottom Outer	30005292
40. Ashlip	See Chart Below
41. Gasket, Fireback	30005209
42. Refractory, Fireback	30005302
43. Retainer, Inner Cover Refractory	30005248
44. Refractory, Inner Cover	30005205
45. Andiron	30002397

Item Description	Part Number
46. Refractory, Access Cover	30006119
47. Leg Leveller	1201745
48. Ashdoor Handle Shaft	1600622
49. Pawl Assy	30005157
50. Ashdoor	30002392
51. Ashdoor Handle (Wood)	1600663
52. Ashdoor Hinge Rod	30002473
53. Cotter Pin, Ashdoor	30001749
54. Ashdoor Hinge Lower	30002404
55. Ashpan Bracket	1601039
56. Lower Side Bracket	30005268
57. Thermostat Handle	1600660
58. Front Manifold	30002407
59. Front	See Chart Below
60. Flue Collar Gasket	30002422
61. Left Door	See Chart Below
62. Door Hinge Strip	1308634
63. Top	See Chart Below
65. Glass Clip Long	1601396
66. Front Door Handle & Shaft	30002717
67. Right Door	See Chart Below
68. Door Gasket	1203588
69. Glass Gasket	1203556
70. Left Door Glass	30005300
71. Right Door Glass	30005299
72. Door Hinge Pin	30002727
73. Spacer (for Damper rod)	1201779
74. Primary Air Valve Assy.	30005324
74a. Primary Air Frame	1307411
74b. Primary Air Rod	30005260
75. Complete Handle Assy	30004175
75a. Handle Base Stub	30002714
76. Thermostat Friction Spring	1201846
77. Thermostat Cable	5005471
78. Thermostat Handle Bolt	1201243
79. Ash Pan Assy	5005746
80. Flue Collar	See Chart Below
81. Leg	See Chart Below
82. Hex Head Jam Nut	1203290
83. Bottom Heat Shield	30002470
83a. Bottom Heat Shield Rt Wing	30005030
83b. Bottom Heat Shield Lt Wing	30005031
84. Grate Bottom	30005294
85. Thermostat Assy.	5005470
86. Washer	1202471
87. Handle Base Stub	30002714

Shell Enamel Parts - Encore Model 2040					
Part Name	Classic	Biscuit	Bordeaux	Ebony	Brown Majolica
Top	30002387	30003055	30002615	30003075	30004879
Left Side	30002388	30003052	30002613	30003072	30004876
Right Side	30002405	30003053	30002612	30003073	30004877
Flue Collar	1305050	30003160	2325050	30003162	30004873
Front	30002393	30003054	30002614	30003074	30004878
Ashlip	30002402	30003051	30002610	30003071	30004875
Left Door Subassy*	30003974	30003984	30003976	30003988	30004882
Left Door	30003938	30003958	30003950	30003962	30004884
Right Door Subassy*	30003975	30003985	30003977	30003989	30004881
Right Door	30003939	30003959	30003951	30003963	30004883
Single Leg	30002396	30003050	30002611	30003070	30004874

Encore 2N1 Service Manual

HISTORY: First Manufactured: August 2010

REPAIR PROCEDURES ENCORE 2N1

REPLACING THE TOP

Materials needed: Encore 2N1 top of the correct finish; 5' of griddle gasket for the top or Griddle Gasket Kit 0003441; gasket cement for the griddle gasket if the kit is not used; damaged.

Tools and time needed: 7/16" wrench; Phillips screw driver. Approximately 1 hour. If performing the service in a person's home, prepare the top ahead of time.

- 1) Take off the rear shroud and flue collar heat shield. Remove the four sheet metal screws (two on each side) and two Phillips pan head bolts in the center of the rear shroud and remove the shroud with the flue collar heat shield attached.
- 2) Lift out the griddle
- 3) Locate the two Phillips pan head bolts holding the flue collar to the back. Reach inside the flue collar and while holding the square nut with a 7/16" wrench, remove the two bolts with a Phillips screw driver and pull the flue collar off the unit.



- 4) With an Allen key, remove the button head screw in the center of the front of the top underneath where the griddle sits.
- 5) Locate the two hex head bolts and washers holding the top to the sides part way back on either side underneath the top. With a 7/16" wrench, remove the bolts and washers and lift off the top.



- 6) Install the griddle gasket on the new top. Re-glue or replace any damaged adhesive gasket on the top of the sides/top/rear of the stove.
- 7) Install the new top and tighten down evenly.

REPAIR PROCEDURES ENCORE 2N1

REPLACING INTERIOR REAR COMPONENTS

Materials needed: One or more of the following interior components:

30005322 - Damper Housing Assembly

30005203 - Fireback Refractory

30005209 - Fireback Gasket

30005217 - Fireback Plate Stainless Steel

30005202 - Refractory Engine

Note: 30005204 Access Cover Refractory, 30005248 Inner Cover Refractory and 30005185 Catalyst are replaceable requiring no tools as per the user manual.

Tools and time needed: 7/16" wrench; Phillips screw driver. Approximately 1 hour.

1. Lift out the Andirons, Doors, Access Cover Refractory, Inner Cover Refractory and the Catalyst (if installed).
2. Follow the procedure on page 4 to remove the top of the stove
3. Locate the two interior side bricks held in place by 2 brackets. Take out the 1/4-20 x 1/2" Hex Head Screws and remove the brackets and bricks.



4. Locate and remove the two retainer brackets held in by 1/4-20 x 1/2" Hex head Screws that hold the bottom of the Fireback Refractory. See photo in the next column.



5. Remove the Damper Housing Assembly. This assembly holds the top of the Refractory fireback in place. Using the 5/32 Allen key supplied with the unit, remove the damper handle.



6. Locate the 4 nuts and washers attached to the through bolts holding the Damper Housing Assembly in place. Using 7/16 wrenches, remove the nuts and bolts holding the assembly and carefully lift the damper housing down removing the damper rod first. Do not lose the damper rod sleeve and washer (see photo next page).

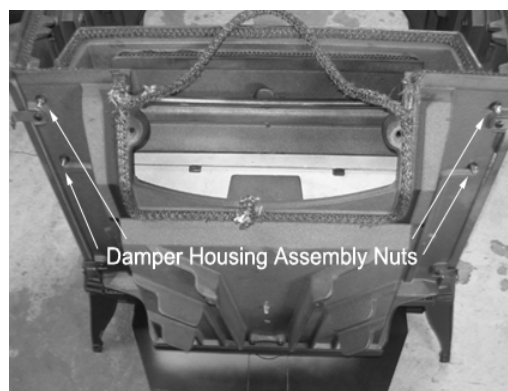

7. The refractory fireback may now be removed.

REPLACING REAR COMPONENTS CONT...

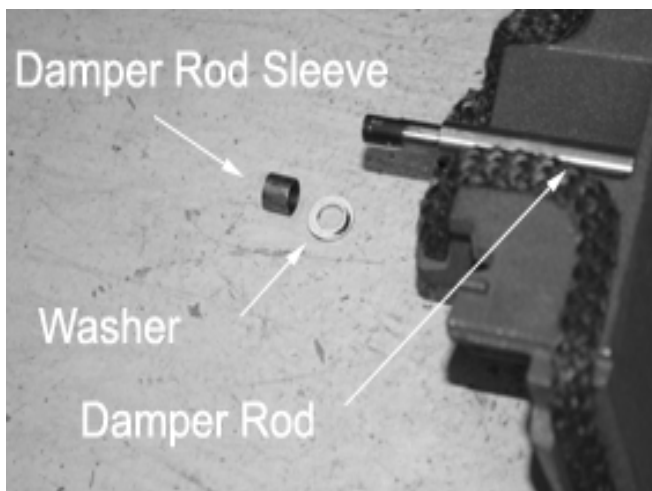

8. Lift out the Fireback Refractory fiber form gasket and the Stainless Steel Fireback Plate exposing the Engine Refractory. The gasket is glued to the SS Fireback Plate before installing and must face forward when reinstalled.



9. Lift out the Engine Refractory showing the rear of the stove.

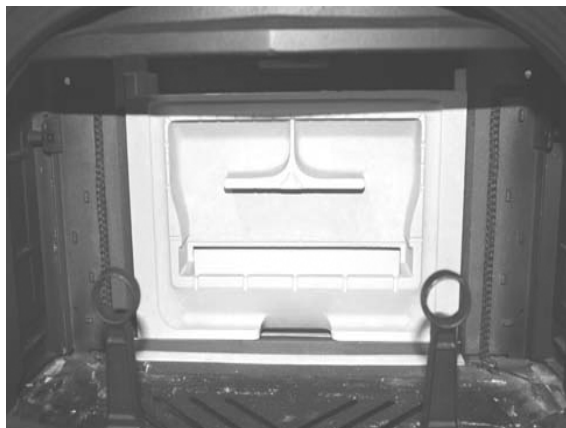

10. If necessary, remove the bolt and washer holding the rear insulation and lift it out.



When reassembling, please take note of the following:

- Ensure the Damper Housing Assembly seals evenly across the Fireback Refractory after tightening and sits just above the guide tab on the right rear of the back. **Do not over tighten the damper bolts.**
- Make sure to insert the washer on the handle end of the damper rod before inserting it into the left side and slide the damper rod sleeve over the rod before attaching the handle stub.
- Before installing the Fireback Refractory, ensure the Engine Refractory is centered on the back and evenly against the two fiber gasket sealing strips.

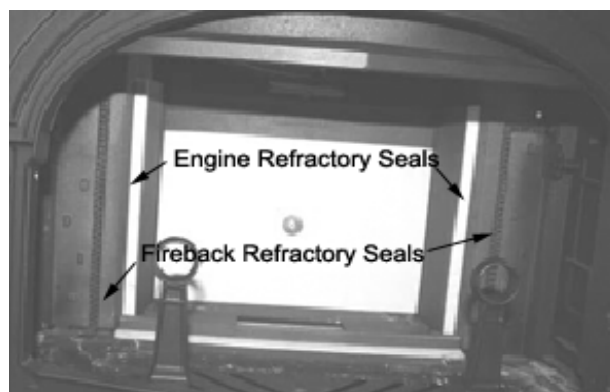

- Make sure to push hard against the bottom of the Fireback Refractory when tightening the bolts on the two retainers to force the assembly in tight and make a good gasket seal on all rear

REPAIR PROCEDURES DEFIANT 2N1

ADJUSTING FRONT DOOR ALIGNMENT

Materials needed: None Required

Tools and time needed: 7/16" wrench; slotted screw driver. Approximately 15 minutes.

1. Adjust the doors one at a time. Open both doors. The hinge pins are held in place by the hinge plate. Adjust one door at a time.



2. For a simple height adjustment, back off the bottom hinge bolt enough so the door will slide up or down and still hold in the new position (about 1/2 turn). For adjustment up, use a slotted screw driver and insert on the top of the bottom hinge pin roll and pry the door gently up. For adjustment down, simply tap the door down. Close both doors to check the adjustment. Retighten the hinge bolt. Do not over torque.
3. For side to side adjustment, back off both bolts slightly and tap the main body of the door to adjust the door in or out at the top or bottom. Close both doors to check the adjustment. Retighten the hinge bolt. Do not over torque.

ADJUSTING FRONT DOOR PAWL

Materials needed: None Required

Tools and time needed: 1/8" Allen wrench supplied with stove; 9/16" wrench. Approximately 15 minutes

1. If the doors on your stove move in after latching, they may require an adjustment to the latch roller pawl. This is part of what should be an annual maintenance check.
2. The roller in the pawl assembly is held on to the cast pawl by a socket head shoulder bolt which is not in the center of the cast pawl.

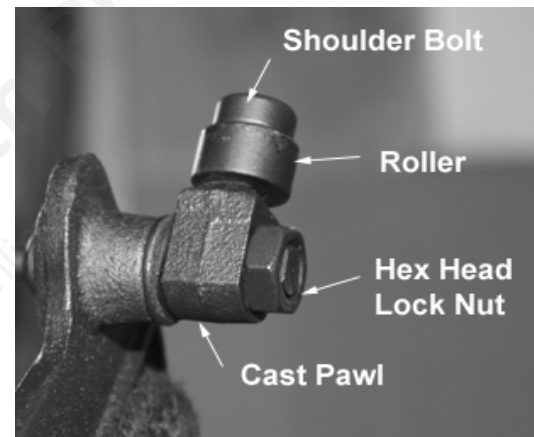

3. To do the first adjustment often necessary after the gasket has become compressed after extended use, first remove the hex head lock nut with a 9/16" wrench. Then back off the Allen screw in the cast pawl and slide the pawl off the shaft of the handle. Turn the pawl around so the roller is now proud of the pawl and reinstall in the same place by matching the Allen screw to the same mark on the shaft flat spot. This adjustment places the roller closer to the roller latch and pulls the door in tighter.
4. If the door still has some movement and needs further tightening, turn out the Allen screw in the cast pawl and slide the assembly slightly further in. Also the washer on the shaft between the pawl and the door may be removed. Retighten the Allen screw and the hex head nut. Remember to re-tighten the hex bolt on the shaft.

Complete Tear Down

Tools Needed: Phillips screwdriver, 7/16 driver

1. Remove the top and interior components as per the earlier service procedures.
2. Lift out the grate in the bottom of the stove.
3. Remove cast iron refractory support.

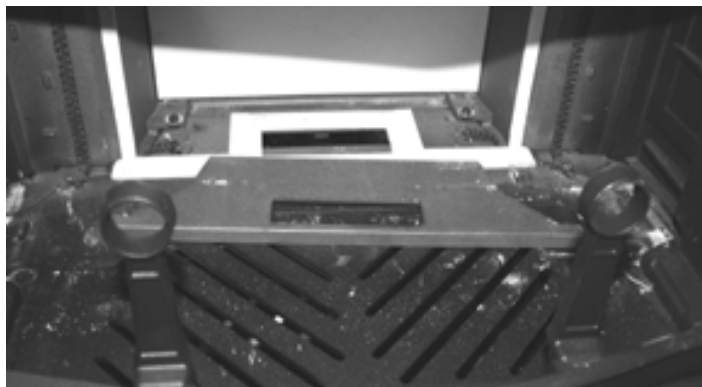

4. Lift out the refractory support fiber gasket that sits underneath the refractory support.

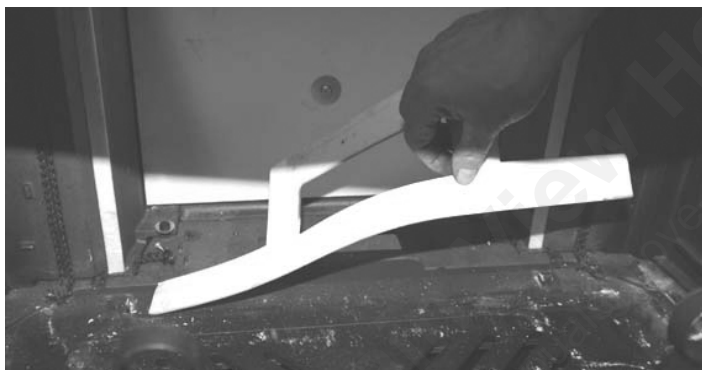

5. Take out the Rear Fiber Board by removing the 1/4 -20 bolt, nut and washer. The back is now open.



6. Remove the air wash manifold attached to the front by two 1/4 -20 x 1 1/2" hex head cap screws.



7. Remove the left and right air manifolds held on by two 1/4 -20 x 1 1/2" hex head cap screws in each manifold. The manifolds are just inside the door opening on either side. See below for the right air manifold being removed.



8. Remove the primary air control thermostat assembly. With an Allen key wrench, remove the primary air control handle assembly.



Complete Tear Down Cont...

9. Slide the primary air thermostat assembly out of the right side and lay it down on the bottom of the stove connected to the cable. Be careful not to lose the spring and washer.



12. Remove the left and right ends. Each is held in by 2 hex head cap screws and washers—one into the back and one into the bottom.



10. See photo below of stove as it should look at this point.



13. Remove the two hex head bolts holding the back to the bottom and take the back off.



11. Remove the front. First lift the self adhesive gasket off the perimeter of the stove top. Remove the three hex head cap screws and washers—one into each side and one into the bottom. Lift the front off the body.

14. Stove should now look like the photo below.



Complete Tear Down Cont...

15. Remove the inner bottom held to the bottom by 2 hex head cap screws.



16. See photo below with inner bottom removed showing the primary air valve.



17. Remove the primary air valve system held on by 2 Phillips flat head bolts and sealed with a gasket. The whole assembly with the cable and thermostat will come out together. When re-installing, make sure the door cable is adjusted so the door fully closed when stone cold.

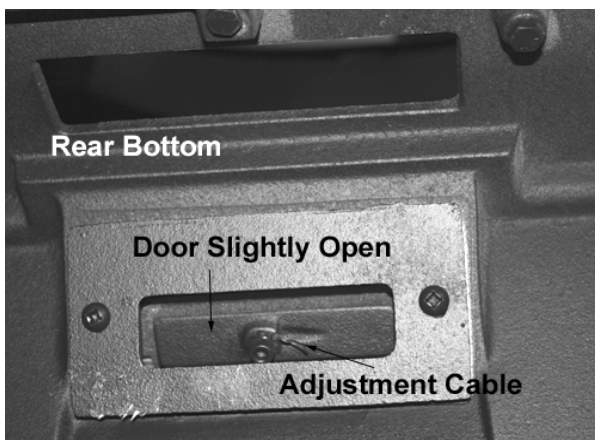

18. The photo below shows the primary air valve assembly from the inside.

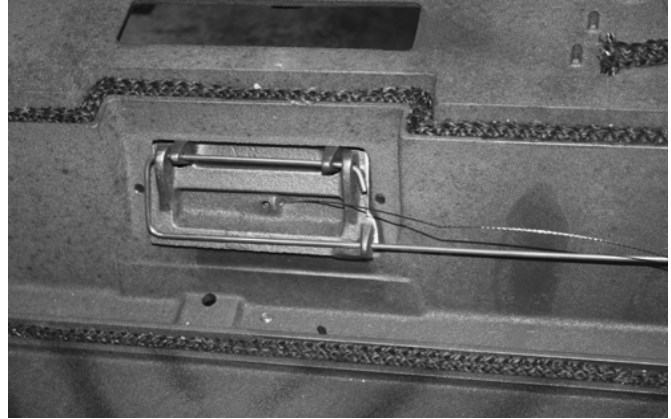

19. Remove the ash lip held on to the bottom

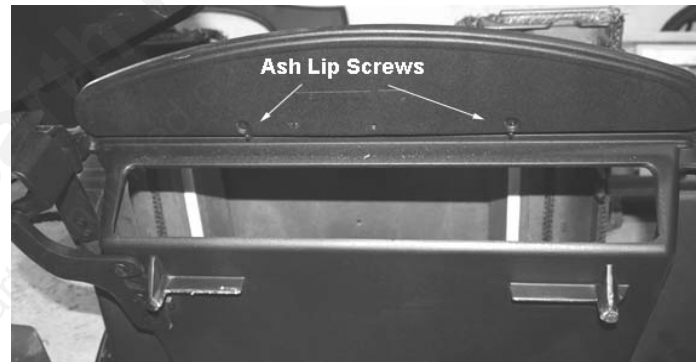

by 2 Phillips flat head bolts.

20. Remove the ash door. Pull the cotter pin out and move the hinge pin down and out. The lower and upper hinges are held on by

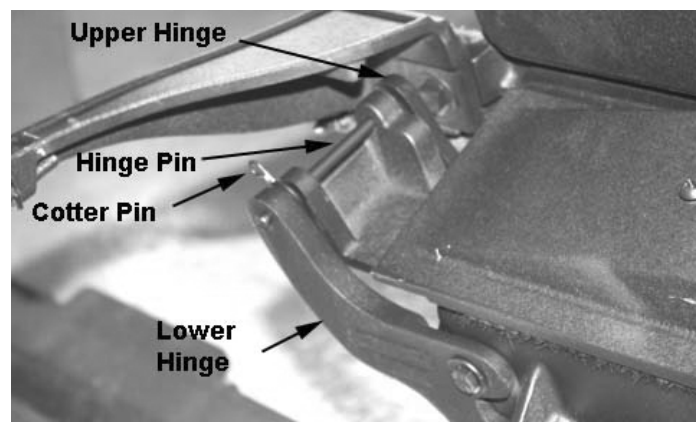

1/4-20 hex head cap screws and washers.

21. Legs are held in by four 3/8-16 hex head bolts and 3/8" washers and may be removed with a 9/16" wrench.

Gasketing

1. Remove the old gasketing paying particular attention to the place where a continuous gasket meets itself.
2. Clean all gasket channels and grooves with a wire brush (hand or power). Remove any stubborn deposits of gasket cement with the appropriate size punch/drive pin or cold chisel.
3. Clean all parts to be gasketed with your shop vacuum. Place clean parts on a clean level surface.
4. Select the appropriate type and size of gasket. Cut to the recommended length allowing you an inch or two excess.
5. For gaskets requiring cement (dampers, griddles etc.), use the 3 oz. tube of gasket cement (part # 120-6122) and place an unbroken 1/8" bead of gasket cement in the channel or groove to be gasketed. Some door gaskets are attached using hi-temp silicone.
6. Starting with one end, press the gasket into the cemented channel or groove. If the gasket meets itself, insure that you have a good joint before trimming excess gasket with shears or side cutters. Do not overlap gasket ends or leave ragged edges.
7. For self adhesive gasket, simply remove the paper glue cover, and follow the instruction in step 6.
8. If possible, place the gasketed part firmly against its normal mating surface in order to seat the gasket evenly in its cemented channel or groove. Remove gasketed part and clean any excess gasket cement that has squeezed out around the gasket before placing aside to dry.

Defiant 2N1 Gasket Requirements

**Please refer to page 5 in this manual for a complete listing of all gaskets used on the Defiant 2N1.*

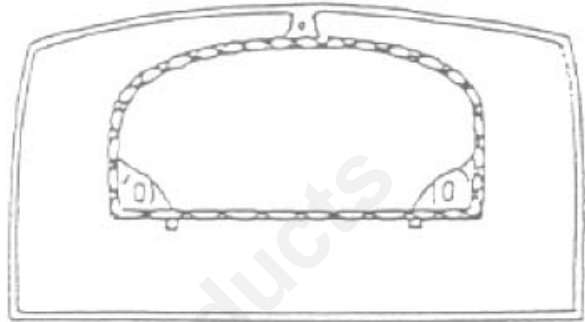

Stove Top: 4½' of 120-3668 - 5/16" Wire Gasket with Fiberglass Core (Griddle Gasket)

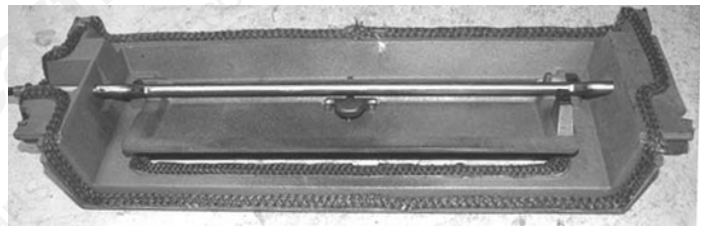

Damper Housing: Housing Seal - 6' of 30001910 - 7/16" Adhesive Gasket; Damper Opening - 3½' of 1203588 - 5/16" Medium Density 6ND

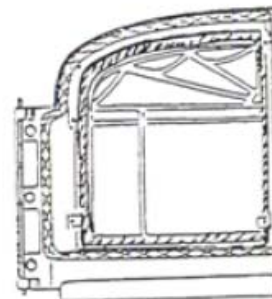

Right Door: Door to Front - 3' of 7000910 - 7/16" Round Black Gasket; Glass Seal - 3½' of 1203556 - 3/16" 4ND Black Gasket

Defiant 2N1 Gasket Requirements Cont...

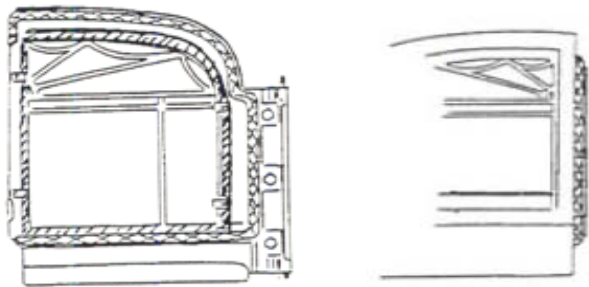

Left Door: Door to Front - 4' of 7000910 - 7/16" Round Black Gasket; Glass Seal - 3½' of 1203556 - 3/16" 4ND Black Gasket

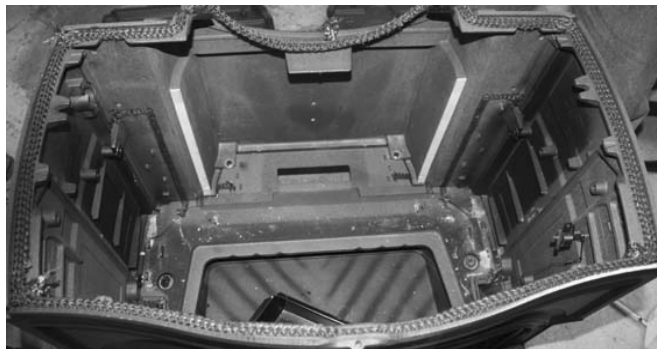

Top of Sides, Front and Back: 6' of 30002422 - 3/8" Adhesive Gasket top seal

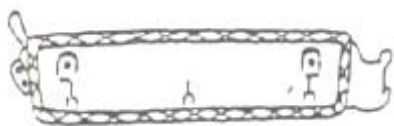

Ash Door: 4½' of 1203589 - 3/8" Low Density 6ND

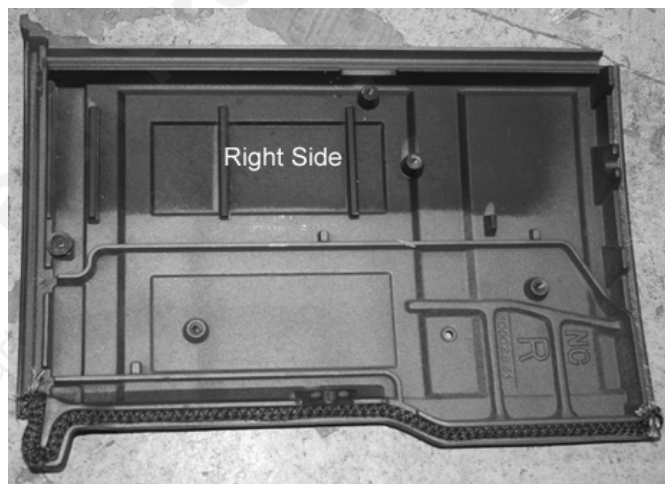

Left and Right Sides: 2½' of 30002422 - 3/8" Adhesive Gasket on each side for Front seal.



Bottom: 16' of 30002422 - 3/8" Adhesive Gasket

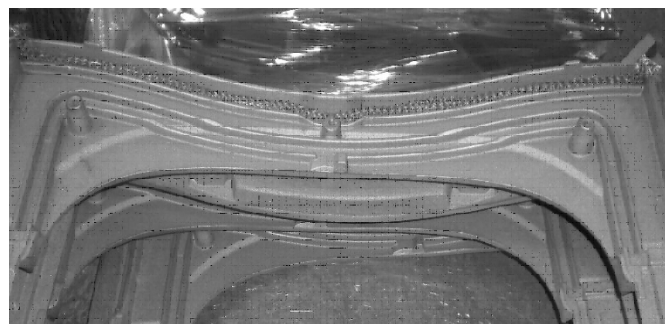

Front: 5¾' of 30002422 - 3/8" Adhesive Gasket for Air Wash Manifold

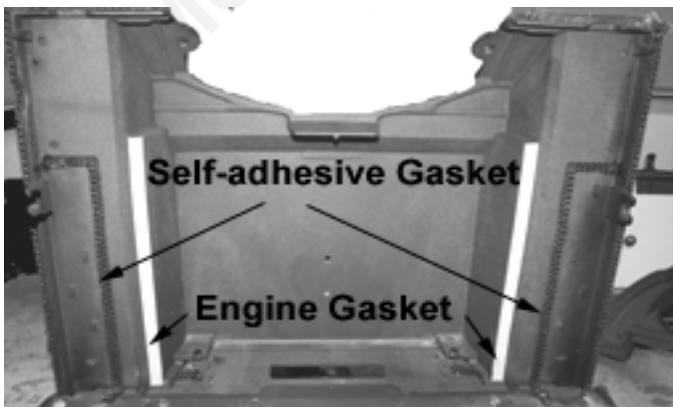

Back: 6' of 30002422 - 3/8" Adhesive Gasket for sides and refractory
Engine Gasket - 2¼' of 30005270 Fiber Form Strip

Defiant 2N1 Gasket Requirements Cont...

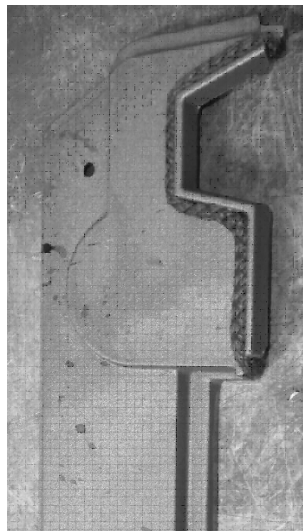
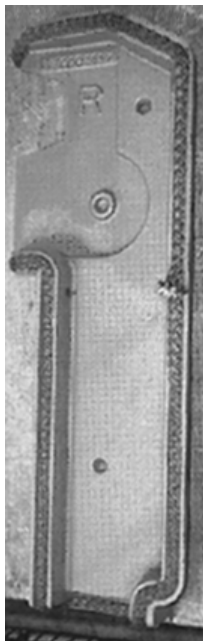

Gasket Wrapped Around the Front

Rear View

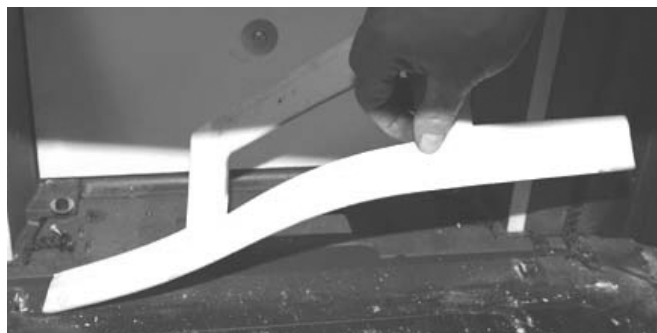

Refractory Support Gasket - fiber form gasket 30005237

Left and Right Air Plates: 4¾" of 30002422 - 3/8" Adhesive Gasket on each air plate for side seal on rear and Air Wash Manifold seal on the front.



Insulator Board - 30005269 bolted to back



Flue Collar : 4¼" of 30002422 - 3/8" Adhesive Gasket partially on the back and partially on the top.



Fireback Gasket—30005209 Behind Fireback Ref.

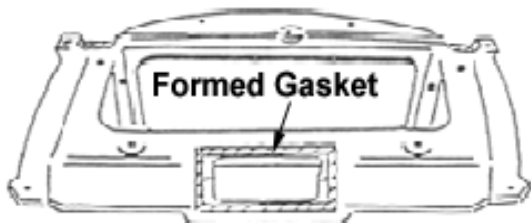

Primary Air Frame—1203518 Fiber Form Gasket

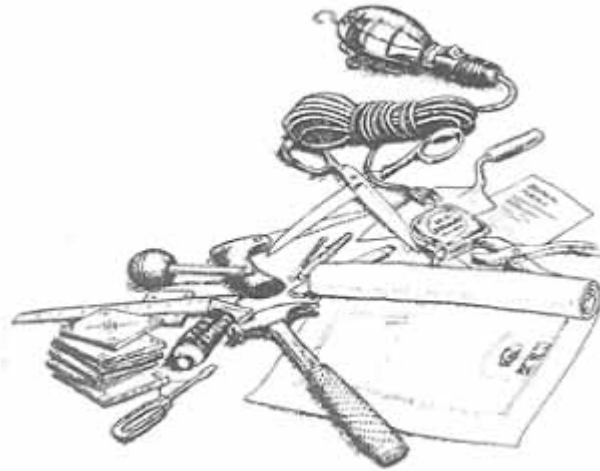

YEARLY MAINTENANCE SUGGESTIONS

The 1975 Defiant 2N1 is a sophisticated combustion machine, and regular “fine tuning” will give you the full benefits of its operating potential.

GENERAL CHECKLIST

- Inspect the chimney for blockage such as squirrels, nests, branches, etc.
- Have a chimney sweep inspect and clean the chimney if necessary.
- Inspect the connector pipe for wear and replace if necessary.
- Touch up painted surfaces as needed with Vermont Castings high temperature stove paint
- Make sure each length of connector pipe, if single wall, is joined by three screws.
- Inspect the stove gaskets for wear using the “Dollar Bill Test” and replace or adjust as necessary.
- Adjust the roller pawls as necessary to maintain good gasket seals on the doors.
- Remove any surface rust and repaint any heat shields or chimney connectors.
- Inspect and clean the catalyst and engine rear pocket visible when the catalyst is removed.
 This inspection and cleaning should be done more than once a year depending on the use of the stove. Time to complete is roughly 5 minutes.

Detailed instructions for all the maintenance suggested above is in the Maintenance Section of the Homeowner’s Installation and Operating Manual

Mountain View Hearth Products
manuals.stove-parts-unlimited.com

Mountain View Hearth Products
manuals.stove-parts-unlimited.com