

INTREPID® II

by

VERMONT CASTINGS®

Owner's Guide

For Use in the U.S.A.

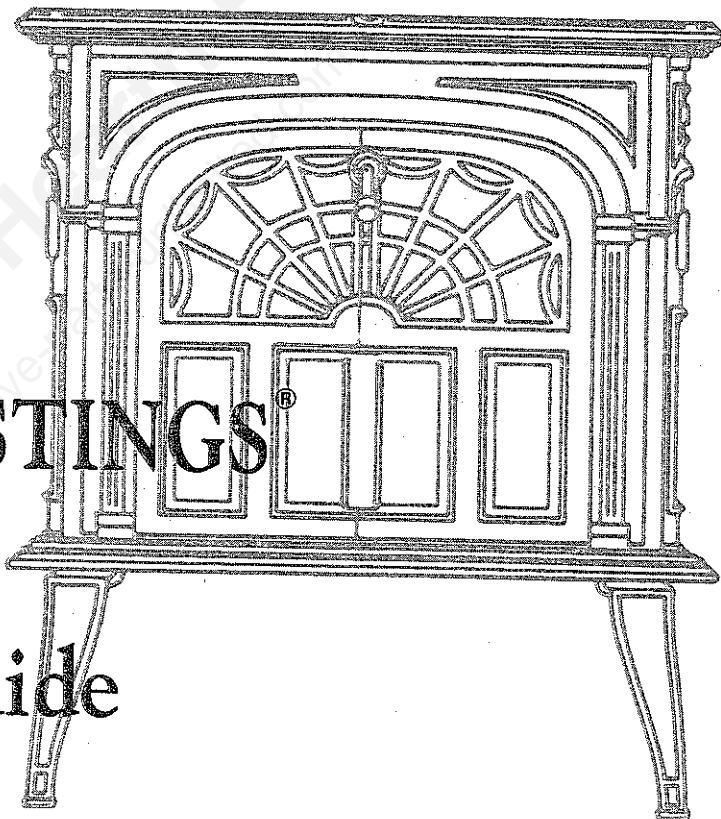

SAFETY NOTICE: IF YOUR INTREPID II IS NOT PROPERLY INSTALLED, OPERATED AND MAINTAINED, A HOUSE FIRE MAY RESULT. FOR SAFETY, FOLLOW ALL INSTALLATION, OPERATION AND MAINTENANCE DIRECTIONS. CONTACT LOCAL BUILDING OFFICIALS ABOUT RESTRICTIONS AND INSTALLATION INSPECTION REQUIREMENTS IN YOUR AREA.

Welcome...

THE FIRE ON THE HEARTH

The Vermont Castings Intrepid II is a specialty stove, designed for the homeowner wishing to take advantage of the latest in woodburning technology. It is perfect for a single room or a new addition, where its diminutive size ensures that it won't take up too much space. Yet it will produce enough heat for an area up to 4,500 cubic feet.

Your Intrepid II reflects all the best traditional New England qualities — pride of workmanship, attention to detail, and good, honest value. Yet while retaining these virtues, the Intrepid II takes a dramatic leap forward into the twentieth century, incorporating a catalytically enhanced combustion system and a high-temperature refractory material originally designed for space exploration. The result of this unique blend of the traditional and the contemporary is an efficient, environmentally sound woodstove to be handed down for generations.



SAFETY NOTICE: IF YOUR INTREPID II IS NOT PROPERLY INSTALLED, OPERATED AND MAINTAINED, A HOUSE FIRE MAY RESULT, FOR SAFETY, FOLLOW ALL INSTALLATION, OPERATION AND MAINTENANCE DIRECTIONS. CONTACT LOCAL BUILDING OFFICIALS ABOUT RESTRICTIONS AND INSTALLATION INSPECTION REQUIREMENTS IN YOUR AREA.

SPECIFICATIONS

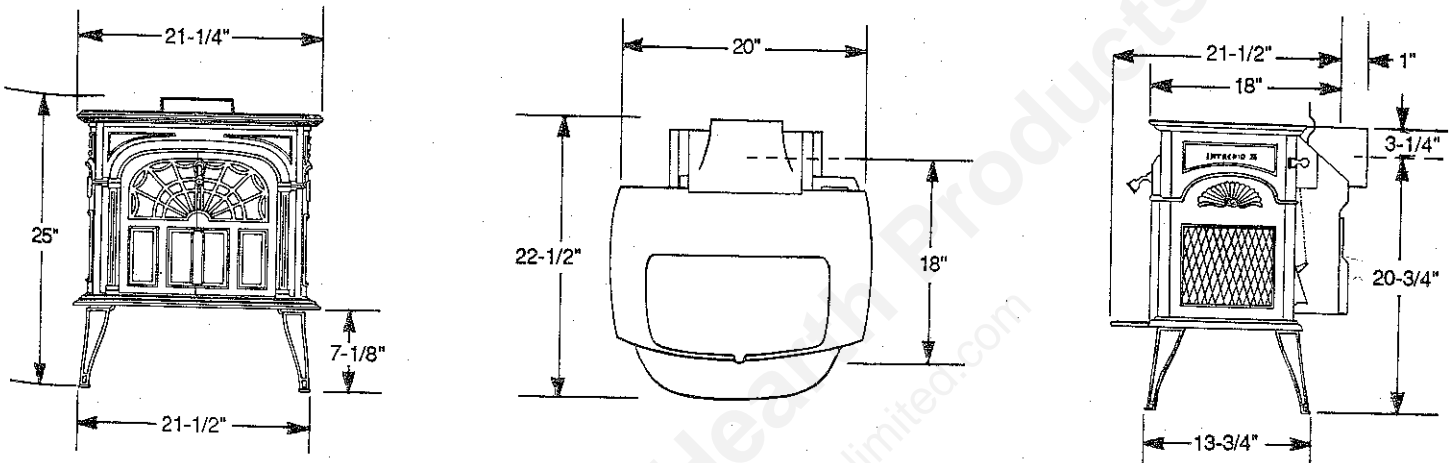

SPECIFICATIONS INCLUDE DIMENSIONS FOR PLANNING PURPOSES ONLY. BEFORE BEGINNING YOUR INSTALLATION, CONSULT YOUR VERMONT CASTINGS AUTHORIZED DEALER OR CALL TEAM FIRESIDE AT 1-800-22-STOVE (1-800-227-8683) FOR FINAL SPECIFICATIONS.

INTREPID II SPECIFICATION CHART				
Range of heat output, hardwood*	5,700 - 24,000 BTU/hr.	Flue size	6"	
Range of heat output, softwood*	5,700 - 18,300 BTU/hr.	Fuel capacity	22 lbs.	
Average area heated	500 - 1000 sq. ft.**	Size & type of fuel	16" wood logs	
Height -	w/regular legs	25" - top exit	Loading	Top or front
		24" - rear exit	Flue exit positions	Reversible - top and rear
	w/short legs	21" - top exit	Secondary air control	Self-regulating
	w/plinth	19-3/4" - rear exit	Primary air control	Thermostatically maintained, manually adjusted
		22-1/2" - top exit	Stove weight	223 lbs.
		21-1/4" - rear exit	Glass panels	High temperature ceramic, 5 mm. thick
Width (leg to leg)	21-1/4"			
Depth (leg to leg)	13-3/4"			

*These values can vary depending on how the stove is operated, the type and moisture content of the fuel used, as well as the design, construction, and climatic location of your home. Figures shown are based on maximum fuel consumption obtained under laboratory conditions and on average wood stove efficiencies.

**These values are based in operation in building-code conforming homes under typical winter climate conditions in New England. If your home is of non-standard construction (e.g., unusually well-insulated, not insulated, built underground, etc.) or if you live in a more severe or more temperate climate, these figures may not apply. Since so many variables affect stove sizing, consult your Vermont Castings Authorized Dealer to determine realistic expectations for your home.

How to Use This Manual

We have tried to make this manual as easy to read as possible. Please read the entire manual at least once before you make the final installation connection. This manual contains a great deal of information and is not easily digested in one sitting. Before you light your first fire, study it thoroughly. Take your time, especially reading the Operation section. The quality of the installation (especially the chimney connector and chimney), and the quality of the fuel being burned will affect the performance of your Intrepid II, but the most important factor is the way you operate the stove.

Save These Instructions. Keeping the manual handy will allow you to refine your operating techniques as you develop skills and confidence. Read it again after you have used your Intrepid II for a while. Points which may be difficult to understand on first reading will become clear as you acquire hands-on experience. Your Vermont Castings Authorized Dealer, with his knowledge of local conditions, is a valuable source of information should you need further assistance. Advisors from Vermont Castings Team Fireside™ are available by calling 1-800-22-STOVE (1-800-227-8683). Every Vermont Castings Authorized Dealer, and every member of Team Fireside™, is committed to your satisfaction with your new Vermont Castings Intrepid II.

Index

Specifications.....	2	Maintenance (cont.)	
Glossary.....	4	Gaskets	
The Inside Story.....	6	The Catalytic Element	
The Combustion Process		The Chimney	
Catalytic Combustion		Installation.....	18
Operation.....	8	Chimneys and Draft	
Fuel		Clearances	
Controls		Floor Protection	
Break-In Fires		Special Installations	
Daily Operation		Chimney Connectors	
Using A Surface Thermometer		Codes and Listings	
Ash Handling		Installation Checklist	
Maintenance.....	12	Safety Tips.....	29
Basics		Exploded View.....	31
Glass		Appendix.....	32
Refractory Package		Warranty.....	33

The Intrepid II has been tested and is listed by the R.F. Geisser Laboratory of East Providence, Rhode Island. The test standards are ANSI/UL 1482 and ANSI/UL-737. The Intrepid II is listed for burning wood. Do not burn other fuels. The Intrepid II is not listed for installation in mobile homes.

The Vermont Castings Intrepid II is in compliance with the standards set forth by the Federal Environmental Protection Agency, 40 CFR Part 60.530(c), as stated on the permanent label attached to this appliance.

Glossary

As you read about your Intrepid II, you may meet some unfamiliar words. The diagrams and explanations presented here will help clarify the information in this manual.

Two typical installations are illustrated. One is a stove connected to a masonry chimney; the other, a stove connected to a prefabricated metal chimney. Fireplace installations are shown in the section on connecting to a fireplace chimney.

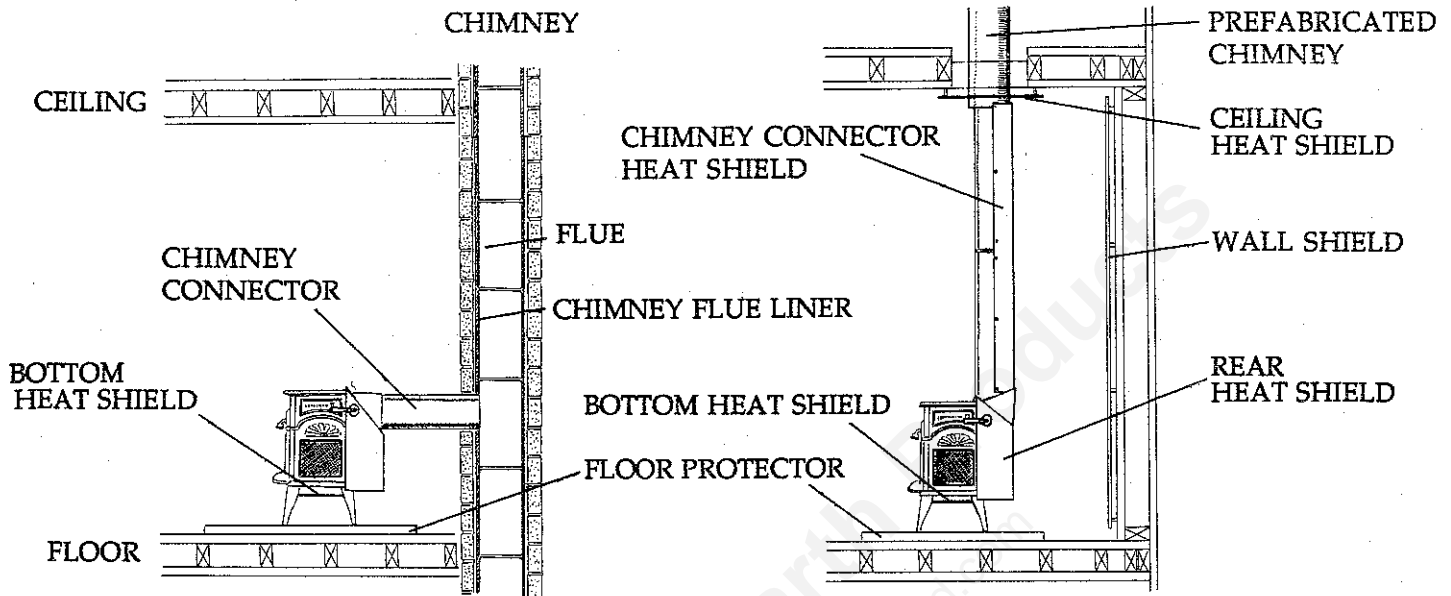

FLUE: An opening which carries off smoke.

CHIMNEY: A masonry or premanufactured metal structure enclosing the flue.

CHIMNEY FLUE LINER: The metal, fire clay or other approved lining in a chimney that protects the chimney walls from the hot gases in the flue.

CHIMNEY CONNECTOR: The sections of single wall pipe that connect the flue collar of the stove to the chimney. Chimney connectors are used inside the house only, and never as a chimney.

SLIP PIPE: A chimney connector of slightly smaller diameter than standard connector pipe. Varying lengths of connector are achieved by sliding the slip pipe into the standard connector.

THIMBLE: An opening which penetrates the outer wall of a chimney, and through which the chimney connector reaches the flue.

TOP-EXITING STOVE: A stove with the outlet from the flue collar pointing upward.

REAR-EXITING STOVE: A stove with the outlet from the flue collar pointing to the rear.

COMBUSTIBLE MATERIAL: Any material which will burn. A material is combustible if any part of it, either on the surface or in the interior, contains a combustible substance. Wood, wallpaper, paint, some veneer bricks, sheetrock, and plastic are some examples of combustible materials.

NON-COMBUSTIBLE MATERIAL: Any material which will not burn when exposed to fire. Metal, brick, tile, concrete, stone, asbestos, and glass are all non-combustible. For a floor, ceiling or wall to be considered non-combustible, all components, including any unseen framework, must be completely non-combustible.

FLOOR PROTECTOR: A non-combustible pad placed on the floor under a stove and extending beyond the stove in all directions. The floor protector serves two purposes. It protects the floor from sparks and falling embers, and protects the floor from heat from the bottom of the stove.

CLEARANCE: The minimum safe distance between the stove, or chimney connector, and nearby combustible surfaces. The clearance distance must be empty space except for non-combustible stove or chimney connector heat shields, or wall shields.

HEAT SHIELD: A non-combustible reflective heat barrier constructed of sheetmetal, attached to the stove (or chimney connector) with a small space between the stove (or chimney connector) and shield. The shield reflects heat back toward the heat source, and away from the surfaces which need protection. The reflecting surface of the shield must face the heat source and should not be painted.

WALL SHIELD: A non-combustible heat barrier constructed of sheetmetal, brick, or manufactured material tested and listed for use as a wall shield, and attached to the combustible surface with a 1" ventilated air space between the wall and the shield. The 1" ventilated air space is required; it cools the combustible wall by providing a channel for air passage.

CREOSOTE: Combustible deposits of condensed smoke (vapors and tar mists). When smoke from incomplete combustion enters a chimney with low flue temperature, creosote can deposit on the chimney flue walls. A subsequent hot fire can ignite the deposits and produce a potentially dangerous chimney fire.

RADIANT HEAT: Heat transmitted by infrared energy waves. This energy is converted to heat when the infrared waves are absorbed by a solid surface, such as your skin, a table, or a wall.

CONVECTIVE HEAT: Heat transmitted by the movement of heated matter (such as air molecules). Warm air rising is a good example of the natural convection of heat. Convective heat transfer can be enhanced by the use of fans or blowers.

FACTORY-BUILT FIREPLACE: A fireplace, most often made of steel, designed to be installed with a prefabricated, factory-built chimney. **NOTE: NOT SUITABLE FOR USE WITH THE INTREPID II.**

ZERO-CLEARANCE FIREPLACE: A type of factory-built fireplace with enough insulation and/or air flow space to allow installation directly next to combustible materials. **NOTE: NOT SUITABLE FOR USE WITH THE INTREPID II.**

MASONRY HEAT FORM: A factory-built metal form around which a code-approved masonry fireplace and a code-approved masonry chimney can be built. **NOTE: SUITABLE FOR USE WITH THE INTREPID II IF INSTALLED ACCORDING TO DIRECTIONS.**

LISTED PRODUCT: A product included in a list by a recognized testing laboratory (such as R.F. Geisser or Underwriters' Laboratories of Canada) indicating that the product has been tested by that laboratory and meets a recognized safety standard.

PRIMARY COMBUSTION: The combustion of the solid portion of a fuel, for wood occurring at 450° F. to 500° F., but possible under certain conditions at temperatures as low as 200° F.

PRIMARY COMBUSTION CHAMBER: The main firebox of the stove in which all primary combustion takes place. Partial secondary combustion also occurs.

VOLATILES: Unburned hydrocarbons released as gases and vapors during the primary combustion of wood or coal. Volatiles can undergo further combustion, and may contain 50% or more of the heat potential of wood. When left unburned, volatiles represent a heat loss, and contribute to pollution.

CHARCOAL: Residue which remains after all the volatiles have been driven out of solid fuel. Primary combustion of charcoal continues until only inorganic ash remains. Primary combustion of true charcoal produces no flame.

SECONDARY COMBUSTION: Combustion of the volatiles released during primary combustion, requiring temperatures in excess of 1000° F. for ignition.

SECONDARY COMBUSTION CHAMBER: A chamber in which combustion of volatiles takes place. The secondary combustion chamber must be able to withstand the high temperatures of 1000° F. or more generated by volatile combustion.

REFRACTORY: A solid material capable of withstanding high temperatures in a corrosive environment. Modern refractories are often ceramic materials.

PARALLEL INSTALLATION: The back of the stove is parallel to the wall behind it.

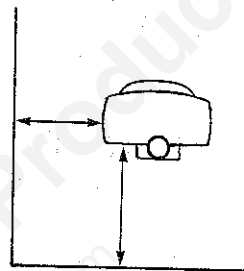

CORNER INSTALLATION: The back of the stove faces the corner of the room.

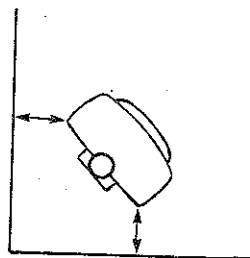

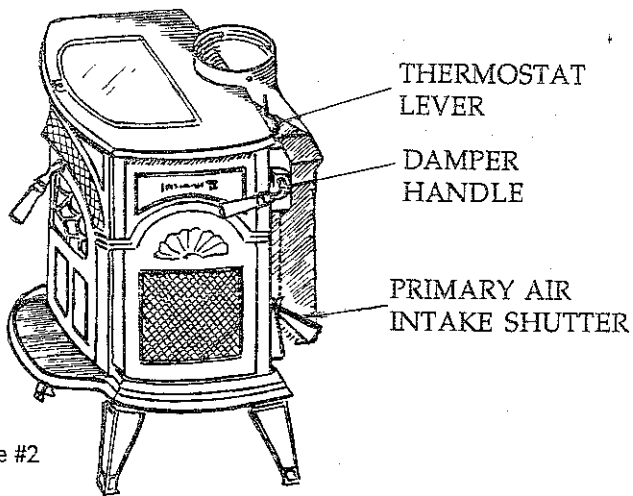

Figure #2

The primary air is metered into the stove through the primary air intake shutter, located on the lower right of the stove back. The automatic secondary air control senses the temperature within the combustion chamber and meters in the correct amount of fresh air for efficient secondary combustion. This automatic control helps compensate for the variable nature of wood fuel, and will offset some (but by no means all) of the problems associated with burning inadequately seasoned fuel.

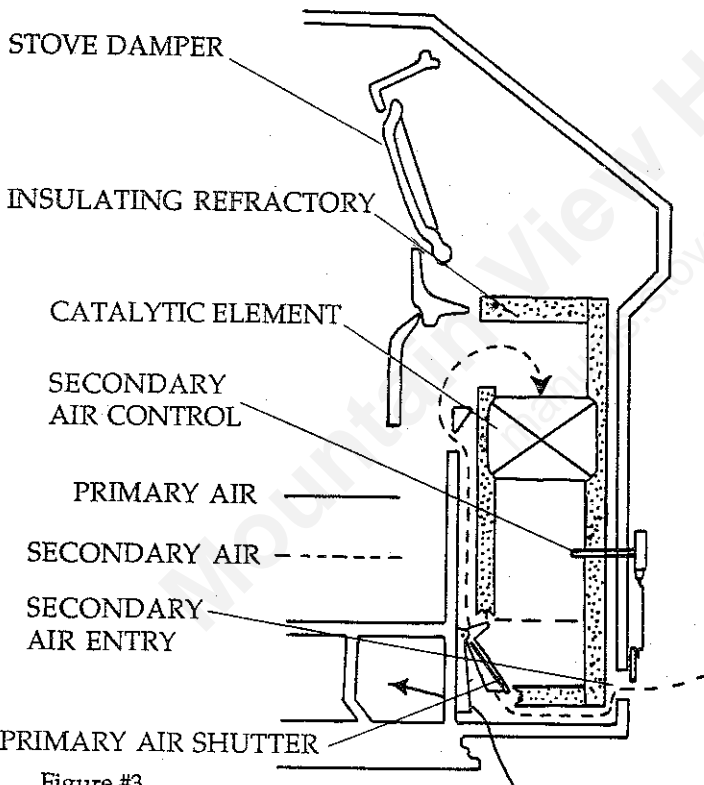

Figure #3

Once catalytic ignition occurs, heat conservation and recycling within the catalytic combustion system will increase temperatures and further encourage complete combustion. The system will be very effective when the stove is operating at temperature ranges too low to sustain normal secondary combustion within the stove body, but high enough to activate combustion in the catalytic combustion system.

THE AIRWASH SYSTEM

After the primary air enters the stove, it travels through two cast iron air tubes underneath the bottom grate. The air tubes guide the air to the front of the stove, and also preheat it. The air then travels through a stainless steel air guide assembly which directs it upward past the glass door panels. Only then does the preheated air enter the primary combustion chamber. The smoke and gases then exit at the top rear of the stove.

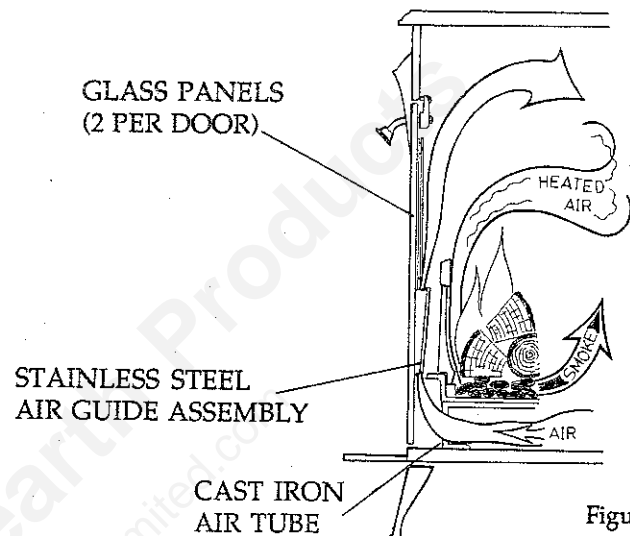

Figure #4

The dual glass panels use a trapped air system similar to the thermal insulating glass systems used in homes. The innermost surface is maintained at a more elevated temperature than the outer surface. In combination with the pre-heated airwash, this provides clear fireviewing over the entire operating range of the stove.

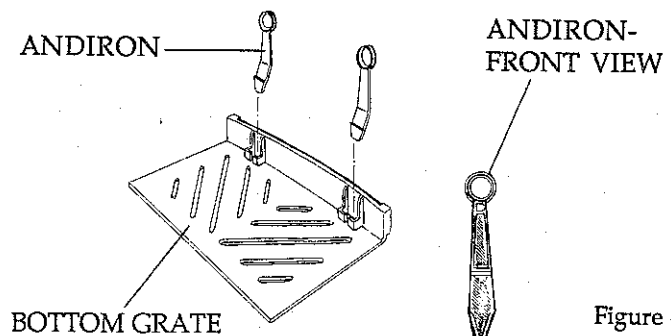

Figure #5

Your stove is equipped with andirons which keep logs away from the glass panels. The andirons are important for maintaining clear fireviewing and should only be removed while reloading through the front doors. Wear heavy stove gloves when removing the andirons and place them on a non-combustible surface until you replace them in the stove. Most stove owners will prefer the convenience of top loading through the griddle and will leave the andirons permanently in place.

NOTE: Always use a spark screen while operating your stove as a fireplace (doors open or removed).

OPERATION

Fuel

The fuel you use can make an important contribution to successful operation. You will experience the best stove performance and overall efficiency by burning 16" firewood that has been split, stacked and air-dried for about one year. Burning inadequately seasoned "green" wood will lower the performance level of your stove and make more work for the stove tender.

The Intrepid II is listed for burning wood. Do not burn other fuels.

Controls

Two controls, the damper handle and the thermostat handle, are used to operate the stove. Internationally recognized symbols cast into the stove body and the thermostat cover assist the operator in their use.

The damper handle, located on the right side of the stove, controls the position of the internal stove damper.

When the damper handle is pointed down (see illustration), the internal stove damper is in the open position. Hot smoke and gases rising from the fire go directly to the flue collar of the stove and to the chimney. The stove is operating in the Updraft Mode.

When the damper handle is pointed to the front, the internal damper is in the closed position. Hot smoke

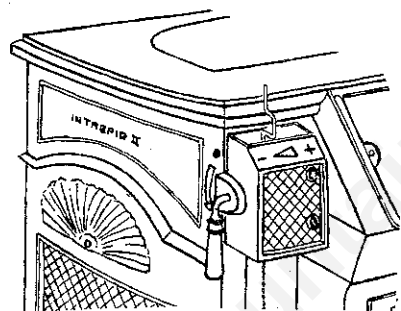

HANDLE DOWN -
DAMPER OPEN

UPDRAFT MODE

Figure #6

and gases rising from the fire are directed through the exit slot in the fireback and through the catalytic combustion system before passing through the flue collar of the stove and to the chimney. The stove is operating in the High Efficiency Mode. There are no intermediate damper positions.

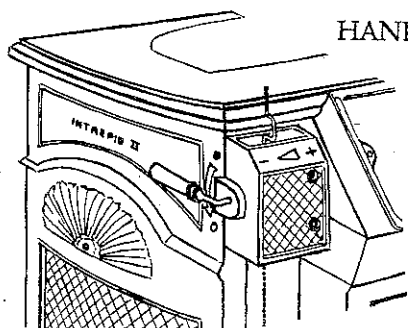

HANDLE TO THE FRONT -
DAMPER CLOSED

HIGH-EFFICIENCY
MODE

Figure #7

The thermostat lever, located slightly above the damper handle, allows manual control of the primary air supply.

As you move the lever toward the left (viewed from the front of the stove), the air shutter opens and admits more air, increasing the rate of combustion and the heat

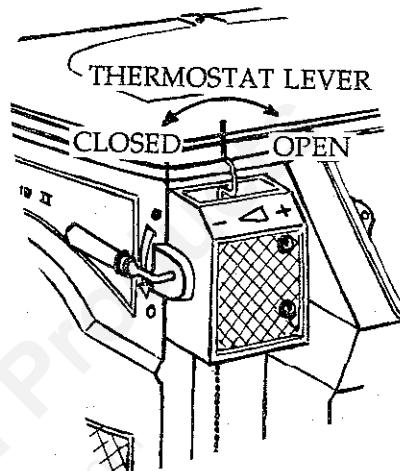

Figure #8

output. As you move the lever toward the right, the air shutter closes and restricts the air supply, lowering the rate of combustion and the heat output. The thermostat lever may be positioned anywhere between the two extremes, offering a wide range of heat outputs.

In addition to manual control of the primary air supply, automatic control is provided by a bimetallic coil which reacts to the heat of the stove. As the stove cools, the coil slowly opens the air shutter and increases the rate of combustion. This action of the coil continues throughout the burn cycle, promoting an even heat output from the stove.

CLOSING THE DOORS

Close the left door (viewed from the front of the stove) first and then the right door. Turn the handle counter-clockwise as you move the handle to the straight up and down position.

The handle should meet some resistance as you turn it to the up and down position, and the doors will draw in slightly.

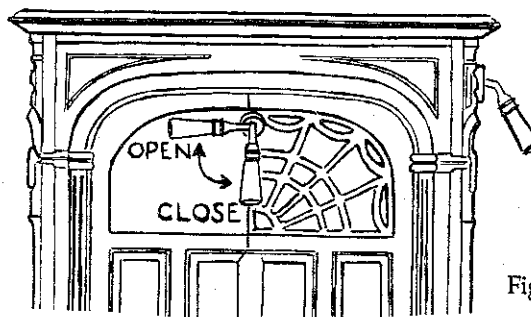

Figure #9

THE BREAK-IN FIRES

Cast iron is a superior material for wood stoves but it

must be treated with respect. It can be broken with a sharp blow from a hammer or from the thermal shock of very rapid temperature changes. A little extra care and thoughtfulness during the break-in period will help promote a long life for your stove. The cast plates expand and contract with changes in temperature. Allow them to adjust gradually to minimize the stresses.

- Open the damper. Open the load door. Open the primary air.
- Lay some crumpled newspaper and kindling on the bottom grate. Place some dry, finely split kindling on top of the paper, followed by two or three pieces of 1" - 2" split, dry wood.
- Light the fire. If your chimney is cold, you may have to prime it by inserting a crumpled piece of paper up into the flue collar area behind and above the Intrepid II damper, then igniting it.
- Gradually build up the fire by adding a few 3" - 5" diameter splits.
- Allow the fire to burn brightly, and then let it die out. Allow the stove to cool.
- Repeat this small to moderate fire six times before proceeding to higher heat output fires or the high-efficiency mode.
- Do not close the damper during break-in fires.

DAILY OPERATION

Follow this procedure once your stove has been properly broken in.

1. SET THE CONTROLS

Open the internal stove damper.

Set the thermostat lever to admit maximum air.

2. KINDLE A FIRE

A strong kindling fire preheats the stove and chimney system. Dry wood will preheat the system faster than inadequately seasoned wood.

Build a paper and kindling fire. Do NOT use glossy advertisements or colored paper, as elements contained in them can poison the catalyst. Be sure your kindling wood is burning well, and then add split, dry pieces of wood about 3" in diameter. Adjust the thermostat for a moderate burn. Continue building the fire until you have established a bed of hot coals 3" to 4" thick on the grate. This may take an hour or more depending on the type of firewood being burned, the moisture content of the wood, and the draft in the chimney.

CAUTION:

NEVER USE GASOLINE, GASOLINE-TYPE LANTERN FUEL, KEROSENE, CHARCOAL LIGHTER FLUID, OR SIMILAR LIQUIDS TO START OR "FRESHEN-UP" A FIRE IN THIS HEATER. KEEP ALL SUCH LIQUIDS WELL AWAY FROM THE HEATER WHILE IT IS IN OPERATION.

Never build a roaring fire in a cold stove. Do not burn pressure-treated, painted or stained wood, processed charcoal, colored paper, plastic, trash, or coal in your stove. Do not use any type of chemical cleaner. Burning these materials in your stove may damage the catalytic combustor.

Do not overfire your stove. Overfiring may damage the stove, and may cause a hazardous condition. If any part of the stove or chimney connector glows red, you are overfiring. Reduce the air supply, and slow the rate of combustion. Failure to operate the stove according to these instructions could cause damage to your stove, void the warranty, or even result in a house fire. Always observe the cautions and follow the procedures outlined in this Owner's Guide.

3. LOAD THE STOVE

Add more wood to the stove. Increase the amount of fuel you load into the stove as you become familiar with your stove and the heating requirements of your home. A very full load will enable you to increase the heat output and length of burn.

NOTE: While loading the stove, be careful not to damage the gasketing by striking it with a log.

4. CLOSE THE DAMPER

When the griddle temperature reaches 450° F., close the damper. Leave the thermostat lever open for approximately 15 minutes, allowing the hot smoke to heat the secondary combustion chamber thoroughly.

5. ADJUST THE THERMOSTAT

After the stove has run with the damper closed for 15 minutes and the catalytic combustion system is thoroughly heated, adjust the thermostat lever to provide the desired heat output.

USING A SURFACE THERMOMETER

Get in the habit of using a surface thermometer to assess your stove's operation. A surface thermometer provides valuable information.

Readings in the 300° F. to 400° F. range indicate low to medium heat output. Readings of 500° F. to 650° F. indicate high heat output. Operating your Intrepid II continuously at griddle temperatures of 750° F. or higher may damage the cast iron or enamel finishes.

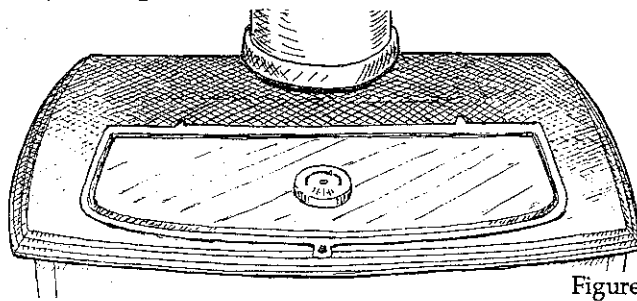

Figure #10

TAKE READINGS WITH THE GRIDDLE THERMOMETER LOCATED ON THE MIDDLE OF THE GRIDDLE.

A surface thermometer also helps the operator decide when to adjust the controls. During start-up and after reloading, when the thermometer registers at least 450° F., the stove is hot enough to begin catalytic combustion. Close the damper and direct the smoke through the catalytic combustion system.

Readings lower than 350° F. indicate it is time to adjust the thermostat lever for a higher burn rate, or to load the stove. Readings over 750° F. call for slowing the burn rate.

The Stages of Combustion During Daily Operation

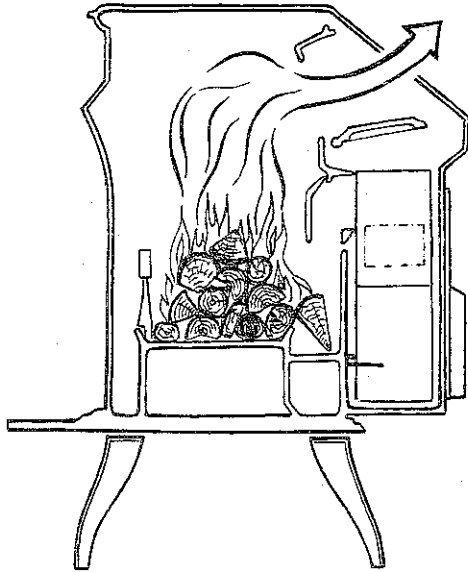

1. **Kindle a fire.** Damper is open. Thermostat lever set to admit large amounts of air. Warm up the stove and establish a charcoal bed. Griddle temperature: 350° F. to 400° F.

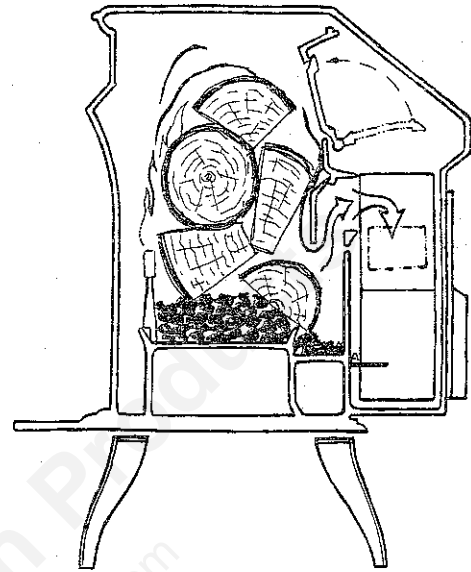

2. **Charcoal bed is well established.** Stove is loaded (smaller pieces on bottom), thermostat lever set to admit large amounts of air. Close damper when griddle temperatures reach 400° F. to 450° F. Volatiles released from fuel begin to burn in the catalytic combustion system.



3. **Fuel burning briskly.** Griddle temperatures 500° F. to 600° F. Thermostat lever adjusted to give desired heat output level. Combustion of volatiles in catalytic combustion system continues. Flaming visible through glass doors at medium heat output level and above. Glowing coals at base of fire are visible at lower heat output levels.

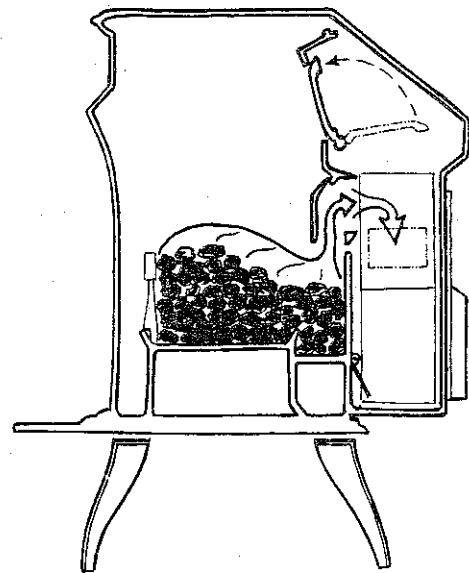

4. **Charcoal burning phase.** Almost all volatiles have been released and burned. Steady heat output continues for several hours. Orange glow visible through glass. Stove should be reloaded when charcoal bed turns down to a depth of approximately 3". Open damper and thermostat. Reload stove as described in step 2.

RELOADING THE STOVE

Stove tending time will be greatly reduced if you reload your stove while the system is still hot and there is plenty of charcoal to re-ignite the fire. Including some smaller pieces of wood in the new load of fuel will help the stove rebuild its thermal momentum quickly.

Follow this procedure when you reload your stove:

- Wear stove gloves.
- Open the thermostat.
- Open the damper.
- Check the ash level in the ashpan; empty and replace the pan if necessary.
- Open the griddle.
- Load wood - smaller, split pieces first.
- Close the griddle.
- Until the surface temperature reaches 450° F., leave the damper and thermostat lever in the open position; this may take 15 to 20 minutes.

•NOTE: If the remaining charcoal bed is relatively thick and if your fuel is well seasoned, it is possible to add fresh fuel (smaller pieces first), close the door and damper, and reset the primary air within 5 minutes.

ASH HANDLING

Ash removal will be required every two or three days during normal stove operation. Most of the ashes will fall through the grate during the course of a burn cycle. Slicing the ashes on the bottom grate with the slicer/poker encourages any remaining ash to fall through the grate slots. **IMPORTANT:** Check the level of ashes in the ashpan before reloading the stove. If the ashes are close to the top edge of the pan, it is time to empty the pan.

Wearing heavy stove gloves, use the hook on the end of the slicer/poker to pull the ashpan part way out of the stove. Use extra care if it is necessary to handle the ashpan when it contains hot coals.

Ashes should be placed in a metal container with a tight fitting lid. The closed container of ashes should be placed on a noncombustible floor or on the ground, well

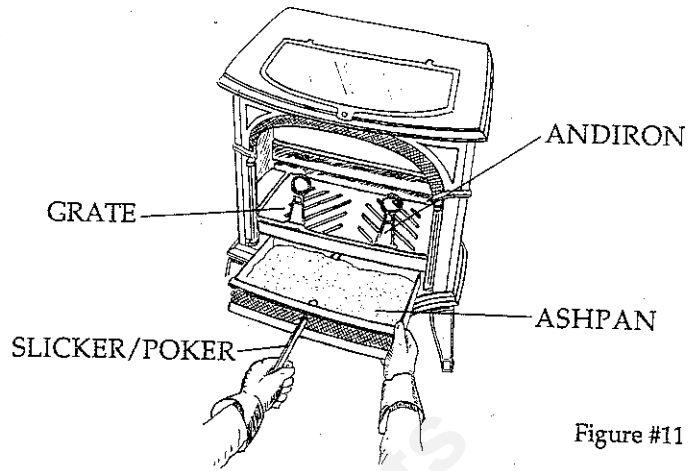

Figure #11

away from all combustible materials, pending final disposal. If the ashes are disposed of by burial in soil or otherwise locally dispersed, they should be retained in the closed container until all cinders have thoroughly cooled.

Before replacing the ashpan, check the bottom of the firebox for any ash which has spilled over the sides and back of the ashpan. Remove this ash so that it does not impede proper air flow under the grate.

CAUTION: Never use a vacuum cleaner to remove ash from the stove; always remove and dispose of ash properly.

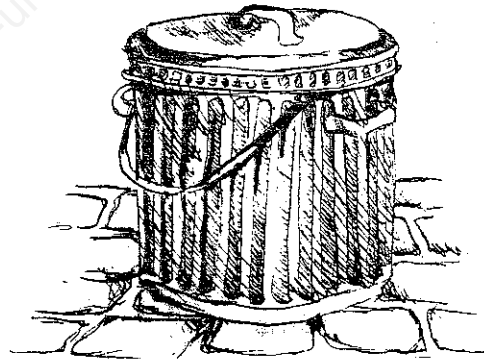

Figure #12

Mountain View

MAINTENANCE

Maintain your stove properly. The benefits in superior performance and safety that good maintenance bring are well worth the time. These guidelines will help you keep your stove in top shape.

The fire must be out and the stove cool before starting stove maintenance. A strong light will be helpful as you inspect and maintain your stove.

Basics

CLEANING:

CAST IRON: An occasional dusting with a dry rag is usually all that is necessary to keep your Intrepid II looking new. From time to time, you may wish to go over the cast iron surface with a damp cloth; do this while the stove is cool, and make sure no water remains on the stove surface.

If your stove's paint needs retouching, allow the stove to cool completely. Brush any areas needing attention with a wire brush, and make sure the entire stove is clean and dry. Remove the griddle and set it aside. Touch up the stove with Vermont Castings High Temperature Stove Paint. Apply the paint sparingly. Two light coats are better than one heavy one.

PORCELAIN ENAMEL: Use a dry rag or soft brush as necessary. Do not use water or other liquids on your stove. Fingerprints can usually be buffed off porcelain enamel with a dry, soft rag. If marks remain, allow the stove to cool completely, then buff with a slightly damp, soft rag. Dry completely before starting a fire, so wet streaks will not leave spots. Never use abrasives or harsh chemical cleaners on the porcelain enamel finish. The enamel may scratch and expose the cast iron, which can then stain or rust.

If you must remove spills or stains from porcelain surfaces, make sure the fire is out and the stove is completely cold before cleaning. Use **ONLY** a kitchen appliance cleaner and polish especially formulated for enamel surfaces. Apply cleaner sparingly with a soft rag, and buff away **ALL** traces of the cleaner.

PRIMARY AIR SHUTTER

The primary air shutter is clearly visible from the back of the stove. The shutter must open and close freely when you move the thermostat lever. If it doesn't, remove the cause of the interference. Check for a lodged piece of charcoal or a bound or stretched chain which needs adjustment. When the stove is cold, the shutter should be closed when the thermostat lever is pushed to its left stop position! At the right stop position, the shutter should be open approximately 70 degrees from the stove back. The ball chain and socket should be lengthened or shortened as needed if the shutter is out of

adjustment.

If you cannot correct the setting, the thermostat coil may be bent or broken. If you need assistance, call your local Vermont Castings Authorized Dealer.

DAMPER HANDLE

The damper is controlled by a handle at the upper right rear of the stove, which is attached to the damper actuator rod with a set screw. Check the set screw every few weeks.

DOOR LATCH

Over a period of time, gasketing around the doors will compress and the latch may need adjustment. To adjust the latch, loosen the small locking nut, extend the striker screw one turn, and re-tighten the small locking nut while preventing the striker screw from turning. Keep making adjustments a little at a time until the setting is right.

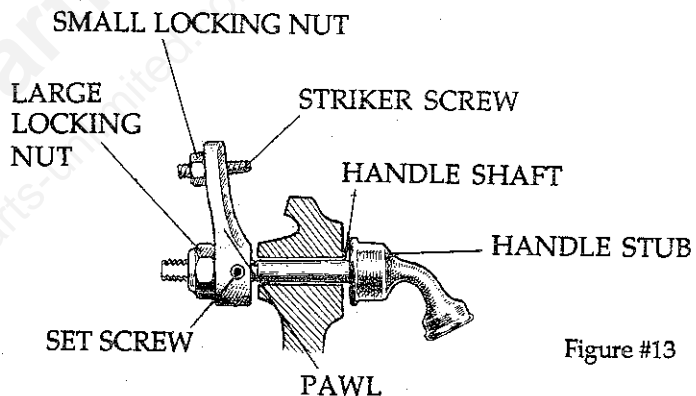

Figure #13

The front doors of the stove should close securely (to prevent accidental opening) and tightly (to prevent air from leaking into the stove) when the handle is in the closed position (pointing down). The handle should resist slightly as it is turned to the closed position and the doors should pull in a little.

Glass

CLEANING

The Intrepid II glass system is designed so that during normal stove operation you may enjoy the view of the fire for extended periods without cleaning the glass. Any carbon deposits which accumulate on the glass will usually burn off during hot fires.

However, the ash residue which accumulates on the glass surface should be removed regularly to prevent etching. To clean the glass, follow this procedure:

- Be sure the glass is completely cool.
- Wash the glass with water. No abrasive or

special glass cleaners are needed.

- Rinse the glass thoroughly.
- Dry the glass completely.

REPLACEMENT

If it is necessary to replace glass, use only the high temperature ceramic glass supplied by Vermont Castings. Do not use substitutes. Do not operate your stove if the glass in the doors is damaged.

Clear a large flat area to use as a work surface. Each glass retainer clip is slightly different, and the fasteners used are different also. As you disassemble the glass components, place each clip and its fastener in order around the perimeter of the work surface. The air deflectors and air guides are also different for the right and left doors. Care in setting up your work area will ensure proper reassembly.

To remove glass:

- Remove the doors from the stove and place them on a padded work surface with the inner sides up.
- Remove the air guide assembly.
- Remove the air deflector and bottom glass clip.
- Remove the two upper glass clips.
- Carefully lift the top glass pane from the door.
- Remove the formed wire gasket.
- Remove the bottom glass pane.

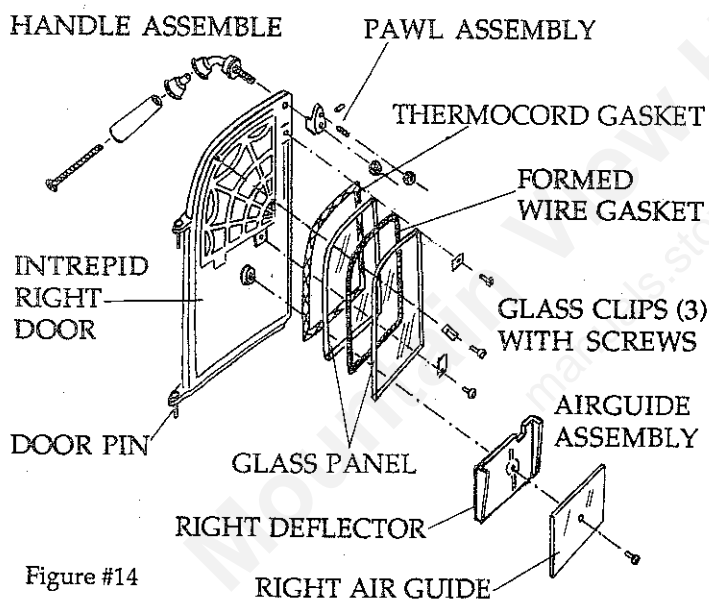

Figure #14

To replace glass:

- Be sure the gasket around the window opening is in good condition. It must be soft and resilient so the glass will seal properly against the door and prevent air from leaking into the stove. Your local Vermont Castings Authorized Dealer can supply replacement gasket if it is needed.
- Center the first pane of glass on the gasket. Clean the inner side of the glass carefully, and dry thoroughly. (When the installation is complete, the inner sides of the glass panes will not be accessible for cleaning without removing the glass.)

Place the formed wire gasket on top of the glass. The gasket may be shaped by hand, if necessary, to make it fit well around the opening.

Clean one side of the second pane of glass, dry thoroughly, and place the glass, clean side down, on the gasket.

Secure the glass by replacing the clips. The stepped flat clip secures the glass to the arch of the door. The short flat clip secures the glass to the upper vertical portion of the door. The longer flat clip secures both the glass and the upper edge of the air deflector to the horizontal glass frame of the door. Alternately tighten the three screws until they are snug; do not overtighten.

- Replace the air guide assembly.
- Replace the doors.

The Catalytic Element

This wood heater contains a catalytic combustor, which needs periodic inspection and replacement for proper operation. It is against the law to operate this wood heater in a manner inconsistent with operating instructions in this manual or if the catalytic element is deactivated or removed.

Under normal operating conditions, the catalytic element should remain active for 2 - 6 years (depending on how much wood is burned). Regular inspections of the chimney and chimney connector are a good way to assess the performance of the catalyst. Using a mirror and strong light, sight up the flue collar and examine the connector for deposits. (If you cannot sight up through the flue collar, you must disconnect the Intrepid II to examine the chimney system components.) Loss of catalytic activity will become apparent during these inspections if the amount of creosote in your chimney and/or connector components increases significantly. The catalyst itself should be examined for physical damage three times per year. It is not necessary to remove the catalyst each time unless you find it in need of cleaning.

If you notice reduced performance in your Intrepid II, and suspect the catalyst may not be functioning properly, follow these steps to pinpoint the cause:

1. Assess your present operating conditions. In Spring or Fall, draft strength is less than in the middle of winter, and there is often a change in performance. Small hot fires work well in moderate weather.

Burning insufficiently seasoned ("green") wood will result in poorer performance than burning properly seasoned fuel. Has your fuel supply changed? You may have to run your stove hotter (more air) to achieve good performance if you are burning green or wet wood. Any changes in operating routine should be considered at this time as a possible reason for changed performance.

2. Should all operating conditions seem consistent with previous experience, remove and inspect the catalytic element using the following procedure:

- Remove the two 1/4-20 x 5/8" Phillips round head screws which attach the cast iron catalyst access panel.

Remove the panel. Loosen and remove the refractory panel that covers the catalytic element.

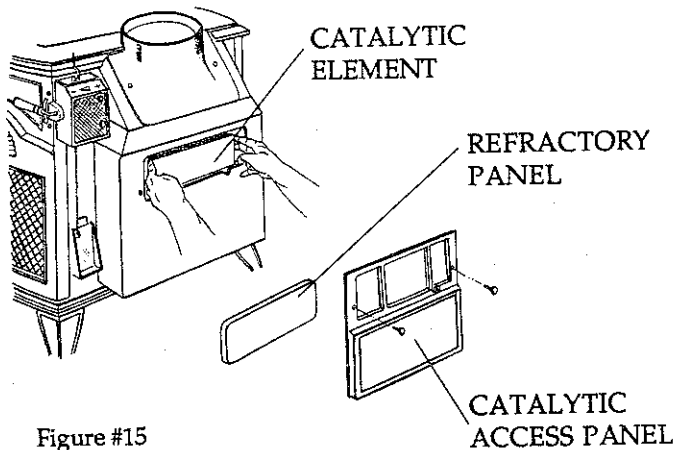

Figure #15

• Looking into the refractory chamber (use a mirror and flashlight if necessary), examine the element for damage or ash buildup. If the element appears to require cleaning, remove it using the following procedure:

• Gently slide the catalytic element out of the refractory chamber. Check the element for a build up of fly ash.

• If the honeycomb is clogged, take the element outside for cleaning.

• A sizeable quantity of ash may be removed from the element. Blow gently through the honeycomb. Inspect the element. Although small hairline cracks will not affect performance, the element should be essentially intact. If elements are broken in pieces or have sections missing, they should be replaced. Call your local Vermont Castings Authorized Dealer for information about a replacement element, item #160-2521.

• If the element appears to be in good shape and all the fly ash has been removed, replace the element in your stove. Slide the element carefully back into the refractory chamber, being sure to seat it securely.

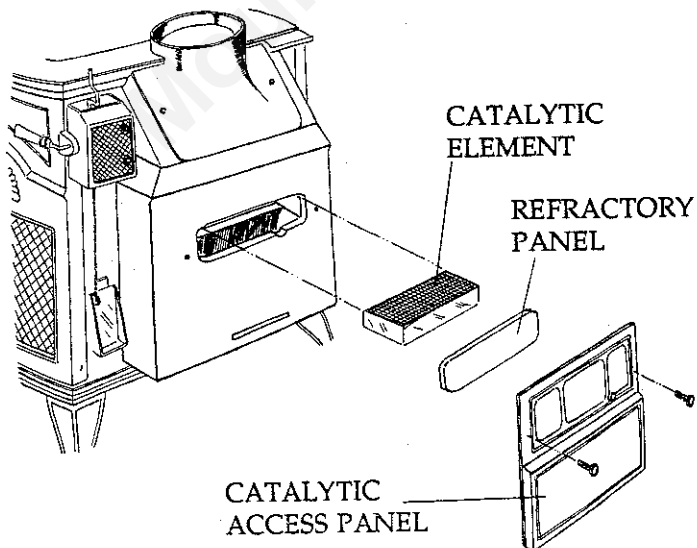

Figure #16

- Reinstall the refractory cover.
- Reinstall the catalyst access panel.
- Clean the chimney and chimney connector.
- Operate the stove in typical manner for two weeks. Inspect the connector frequently during this period.

• A significant reduction in the observed creosote build-up rate is a good indicator that the performance change was due to fly ash deposits on the catalytic element. Continue with regular chimney system inspections to insure proper performance is being maintained.

• Continued observation of significant creosote build-up is a good indicator that the catalytic element needs to be replaced.

The Refractory Package

The refractory package which houses the catalytic element and secondary combustion chamber should be inspected annually for a build-up of fly ash and cleaned if necessary.

Follow this procedure:

- Remove the ashes and clean the firebox.
- Remove the andirons.
- Reach inside the stove with a pair of pliers and turn the two clamps that secure the upper fireback 90 degrees. Turn the left clamp clockwise, and the right clamp counterclockwise. If you must tap the clamps loose, use a small soft faced hammer.
- Grasp the upper fireback by its vertical ribs and remove it. Pull the left side out first.
- Clean the left and right exhaust pockets of the refractory package of all ashes and debris. Use a shop vac, and be careful — the refractory material is very fragile. Do not gouge the material.
- Inspect the gasketing which seals the upper fireback to the damper frame, stove back and lower fireback, and replace if necessary.
- Replace the upper fireback. Angle the right end in first. You must insert the lower right corner of the upper fireback behind the cast iron ramp on the upper right of the rear air tube. Swing the left end of the fireback into position. Refer to the exploded view diagram as you work.
- Twist the tabbed ends of the right and left clamps down against the wedges cast in the stove back. Tap the clamps down until the tabs are horizontal.
- Replace the andirons.

Gaskets

The gaskets used in the assembly of your Intrepid II play an important part in ensuring consistent, reliable performance. Inspection of the gaskets and replacement when necessary is an important part of routine maintenance. Gasketing is used to guarantee that the incoming air and outgoing combustion gases flow through the stove along the proper pathways. All the gaskets in your Intrepid II are fiberglass, secured with Vermont

Castings High Temperature Stove Gasket Cement.

Light colored streaks on the inside of the stove near the door or griddle openings may indicate air leaks due to worn or damaged gasketing. Check for leaks by shining a strong light along gasketed seams to see if the light leaks through. While minor leaks may be repaired by building up the gasketing in just the area of the leak, it is usually better to completely replace the gasketing in the door or griddle. Your local Vermont Castings Authorized Dealer can supply the proper size replacement gaskets.

The gasket seals between stove parts which move frequently or which are necessary to preserve the stove's air-limited quality, must be checked regularly for wear or deterioration. These are the gaskets used:

To seal the griddle to the stove top (1/4" diameter, wire reinforced).

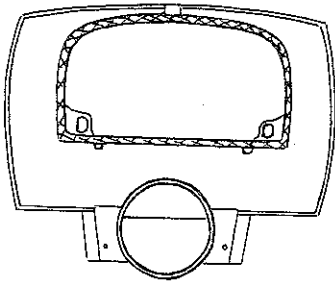

Figure #17

To seal the catalyst access cover to the stove back (5/16" diameter).

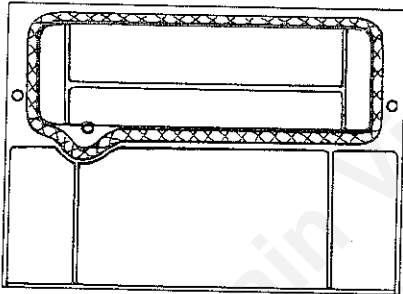

Figure #18

To seal the door frame to the arch of the stove front, and to seal the two door halves to each other (5/16" diameter).

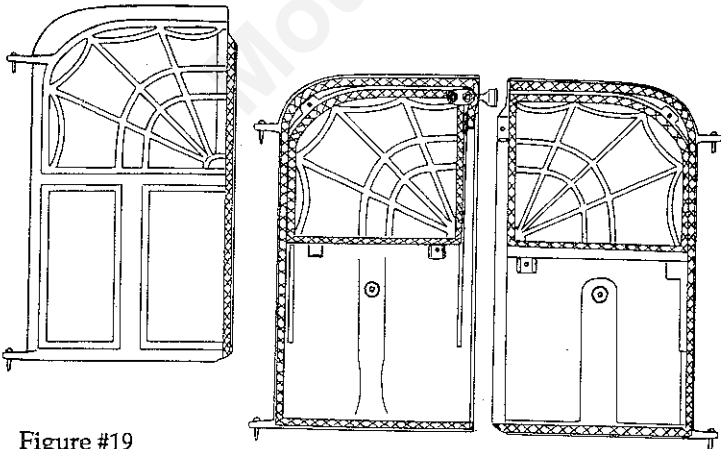

Figure #19

To seal the outer glass pane to the door (1/8" diameter).

To separate and cushion the two glass panes (preformed).

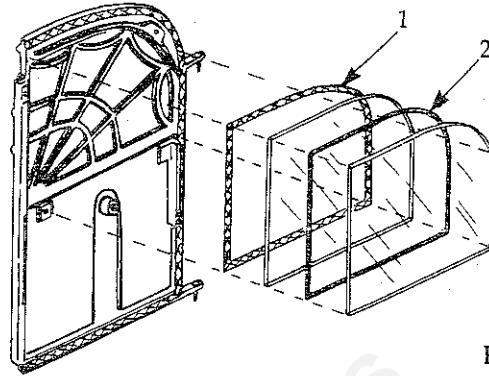

Figure #20

To seal the upper edge of the damper frame to the stove top (1/4" diameter).

To seal the damper to the damper frame (5/16" diameter).

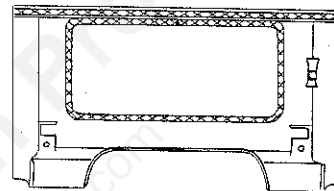

Figure #21

Additional gaskets are used in stove construction, but because they form seals between non-moving parts, they are not as prone to wear or deterioration. If for any reason, however, your Intrepid II is disassembled, check the following gaskets:

To seal the lower edges of the damper frame to the upper fireback (1/4" diameter).



Figure #22

To seal the upper edge of the lower fireback to the lower edge of the upper fireback.

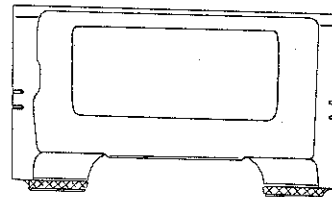

Figure #23

To seal the stove back to the vertical edges of the upper and lower firebacks; also to the damper frame; also to the bottom edge of the lower fireback (1/4" diameter).

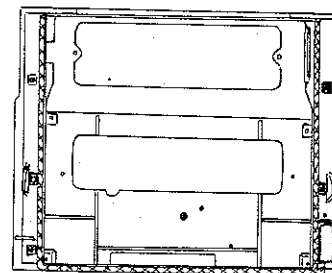

Figure #24

To seal the flue collar to the upper stove back (1/4" diameter).

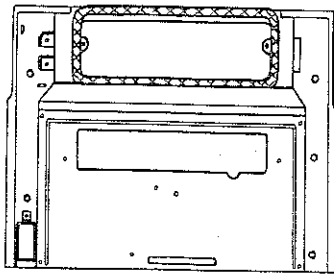

Figure #25

Anytime you remove or replace parts is a good time to examine the exposed gasketing. Replace any gasket which appears frayed or worn. Pay particular attention to any point where a continuous gasket meets itself. Follow this procedure to replace worn gaskets.

- Remove the old gasketing.
- Clean the gasket channel or groove with a wire brush. Remove stubborn deposits of cement with a cold chisel if necessary.
- Clean all parts to be gasketed. Place on a level clean surface.
- Select the appropriate gasket. Cut to the recommended length plus a 1" - 2" excess.
- Place an unbroken 1/8" bead of gasket cement in the channel or groove.
- Starting at one end, press the gasket into the channel. Where gasket meets, insure a good joint before trimming any excess. Do not overlap or leave ragged edges.
- If possible, place the gasketed part firmly against its normal mating surface to seat the gasket evenly in its channel or groove. Remove the gasketed part and clean away any excess gasket cement before placing the part aside to dry.

DAMPER ADJUSTMENT

When the stove is in the damper closed mode, the

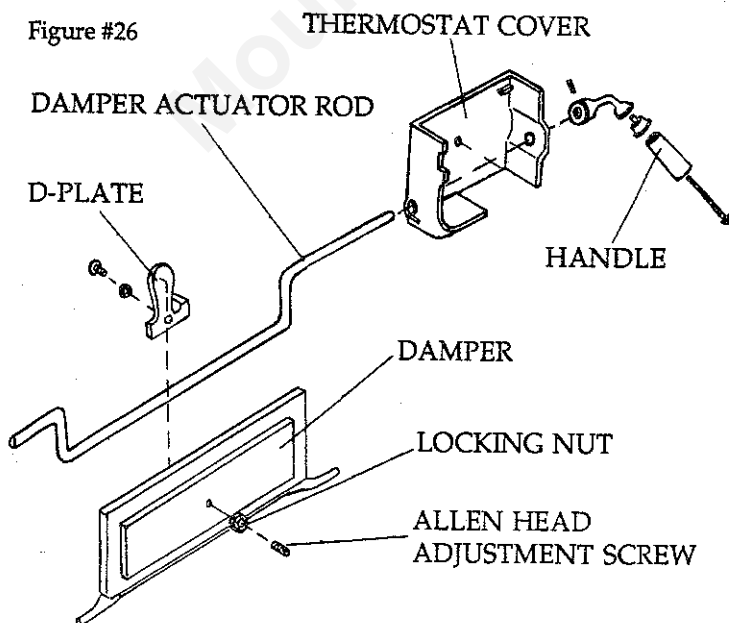

Figure #26

pressure of the actuator rod against the D-plate insures a good seal between the damper and the damper housing. After a period of time, this pressure may need to be increased. With the damper in the closed position, loosen the 7/16" locking nut located in the center of the damper. Using a 1/8" Allen wrench, turn the Allen screw a full turn in the clockwise direction. Test the damper mechanism for snugness, and continue adjusting the Allen screw as needed. Tighten the 7/16" locking nut when the mechanism operates smoothly but firmly.

The Chimney System

CREOSOTE

Although your Intrepid II has been designed to significantly reduce creosote build-up, it is not a substitute for regular chimney inspection and maintenance. For safety, good stove performance, and to protect your chimney and chimney connector, inspect your chimney and chimney connector on a regular schedule. Clean the system if necessary. Failure to keep the chimney and connector system clean can result in a serious chimney fire.

When wood is burned slowly, it produces tar, organic vapors and moisture which combine to form creosote. The creosote vapors condense in the relatively cool chimney flue of a slow-burning fire. As a result, creosote residue accumulates on the flue lining. When ignited, this creosote makes an extremely hot fire within the flue system which can damage the chimney and overheat adjacent combustible material. If creosote has accumulated, it should be removed to reduce the risk of a chimney fire.

We suggest you inspect the system every two weeks when you first start burning your stove. Your experience maintaining the stove and chimney system may show that inspections every two weeks are not necessary, but be sure to inspect the system at least every two months.

To inspect the chimney, let the stove cool completely. Then, using a strong light, sight up through the flue collar into the chimney flue. If it is not possible to inspect the flue system in this fashion, the stove must be disconnected to provide better viewing access.

Clean the chimney using a specially designed brush the same size and shape as the flue liner. Flexible fiberglass rods are used to run the brush up and down the liner, causing any deposits to fall to the bottom of the chimney where they can be removed through the clean-out door. The chimney connector should be cleaned by disconnecting the sections, taking them outside, and removing any deposits with a stiff wire brush. Reinstall the connector sections after cleaning, being sure to secure the individual sections with sheetmetal screws.

If you feel any uncertainties about chimney inspection, contact your local Vermont Castings Authorized Dealer, or engage a professional chimney sweep in your area to perform the inspection and cleaning of the chimney.

INSTALLATION

Chimneys and Draft

Understanding how your chimney contributes to stove operation is essential if you are to obtain optimum performance from your Intrepid II. The chimney provides a safe pathway for hot smoke and exhaust gases to exit from the stove, but in addition, the chimney strongly influences the "draft" necessary for operation of your stove.

Draft is the force which produces a flow of warm gases up and out of the chimney, and draws fresh combustion air into the stove. Your Intrepid II does not come equipped with "draft". Draft is the result of a difference in weight (due largely to a difference in temperature) between the gases inside the chimney, and the gases outside the chimney. Because gas expands when heated, warm gases inside the chimney weigh less than the cooler gases outside. This difference creates the pressure necessary to produce and sustain draft.

As the lighter, more buoyant gases rise up the chimney, draft causes a flow of cooler air into the stove. When starting a fire in a cold stove on an unheated chimney, it may be necessary to provide a little assistance by inserting several sheets of crumpled newspaper into the flue collar area and igniting them.

There are other factors which influence draft, such as barometric pressure, wind speed and direction, the height, configuration and size of the chimney, and the airtightness of the home itself.

OUTSIDE AIR

In some modern, super-insulated homes, the air necessary for combustion is inadequate due to restricted air infiltration into the dwelling. (Infiltrated air is simply that air which finds its way into a home through various cracks and openings in the foundation, along windows and doors, and at other areas which are not weathertight.) If the stove is competing with kitchen or bath exhaust fans for available air, the situation is aggravated further. Where poor draft is the result of a low infiltration rate, opening a ground floor window in the vicinity of the stove, or installing a permanent outside air supply, will often alleviate the problem.

In some areas, bringing air for combustion from outside the home directly to the air inlet of the stove is required for new construction. When the air supply for the fire is brought directly from the outside, it is not affected by variations in pressure within the house. Improved stove performance often results. An Outside Air Adaptor Kit, Item #3258, is available from your local Vermont Castings Authorized Dealer.

EFFECTS ON OPERATION

A strong draft will allow you to successfully fine-tune the Intrepid II's performance by adjusting the primary air supply to determine the rate of combustion and heat output. With a strong draft, you can restrict the primary air supply and lower the heat output without risk of suffocating the fire.

A strong draft will be maintained by operating your stove so that combustion gases entering the chimney are hot, and stay hot. No cool air must be allowed to enter the chimney without first having passed through the stove. Make sure that any clean-out doors and thimbles are sealed tightly, and that the chimney is structurally sound.

Weak draft situations are characterized by smoking and odor problems in the house, low heat output, and difficulty maintaining a fire, especially at low thermostat settings. The reverse situation, overdraft, is rare, but can be recognized by short burn time, poor response when trying to slow down the fire, or by any part of the stove glowing red. (The more common cause of these symptoms, however, is poor maintenance. Following recommended maintenance procedures will ensure consistent stove performance.)

Following the stove manufacturer's recommendation on both chimney size and height will also help ensure adequate chimney flow capacity. Flow capacity measures the ability of the chimney to evacuate combustion gases quickly. Even the strongest draft cannot overcome an insufficient flow capacity; the result is a back up of combustion gases in the chimney which forces smoke out of chimney connector joints or the stove itself. Remember, the Intrepid II and the chimney must function as a unit. For optimum performance, they must be sized properly for each other. Your Vermont Castings Authorized Dealer can help you assess your existing chimney or plan a new one for best stove operation.

CHIMNEY GUIDELINES

NEW CHIMNEYS

Both masonry and prefabricated metal chimneys work well. A new masonry chimney should be constructed to conform to the standards of your local building code or a recognized national code. Masonry chimneys must be lined with code-approved masonry or pre-cast refractory tiles, stainless steel pipe, or a code-approved poured-in-place liner. The chimney must have a tight sealing clean-out door.

A prefabricated metal chimney should be one tested and listed for use with solid-fuel burning appliances to the High-Temperature (H.T.) Chimney Standard UL-103-1985 (2100° F.). Be sure to follow the chimney manufacturer's instructions precisely if you must pass the

chimney through a combustible wall or ceiling. Special accessories may be necessary for this type of installation, and can be obtained from the chimney manufacturer.

TILE LINED MASONRY CHIMNEY

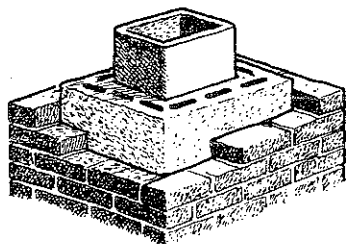

PREFABRICATED DOUBLE-WALL INSULATED CHIMNEY

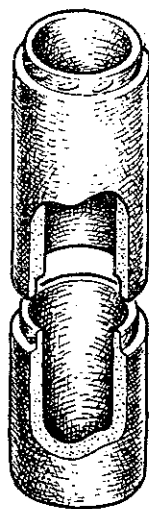

Figure #27

The chimney should extend at least 3 feet above the highest point where it passes through a roof, and at least 2 feet higher than any portion of a building within 10 feet.

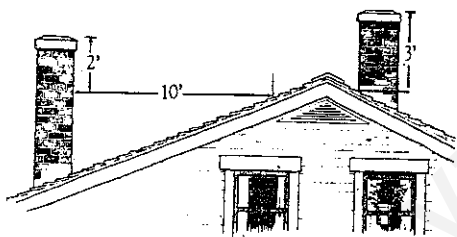

Figure #28

For proper draft and good performance, any chimney used with a Vermont Castings wood or coal burning stove should extend at least 16 feet above the flue collar of the stove.

DO NOT CONNECT YOUR STOVE OR INSERT TO A CHIMNEY FLUE SERVING ANOTHER APPLIANCE.

EXISTING CHIMNEYS

An existing masonry chimney may work well, but be sure to have it carefully inspected before using it. Defects may have gone unnoticed if the chimney previously was used only occasionally. Defects must be repaired before the chimney is used with your stove. If you are not sure that you can make the inspection yourself, your local professional chimney sweep, building inspector, or fire inspector will be able to make the inspection or direct you to someone who can.

The chimney should be thoroughly cleaned before being used with your stove.

First, check to see that the chimney has a lining. Do not use an unlined chimney. Your local Vermont Castings

Authorized Dealer or chimney sweep can help you with information about approved chimney lining systems. In addition, look for and repair (if necessary) these defects:

- A. Improper chimney height and roof clearance; check local building codes for proper construction.
- B. Chimney cap deterioration; rebuild.
- C. Creosote stains indicate flue damage; inspect and repair.
- D. Blockage within flue; remove.
- E. Improper clearance between chimney and combustible materials. Generally, a clearance of 2" (50 mm.) is required to all combustible walls and framing members; check local codes.
- F. Improper clearance between smoke chamber and adjacent framing members; check local codes.
- G. Creosote accumulation; chimney needs thorough cleaning.
- H. Structural deterioration of the fireplace; must be repaired before use.
- I. Loose or broken bricks or mortar; replace and remortar.
- J. Loose or broken clean-out door; repair or replace.

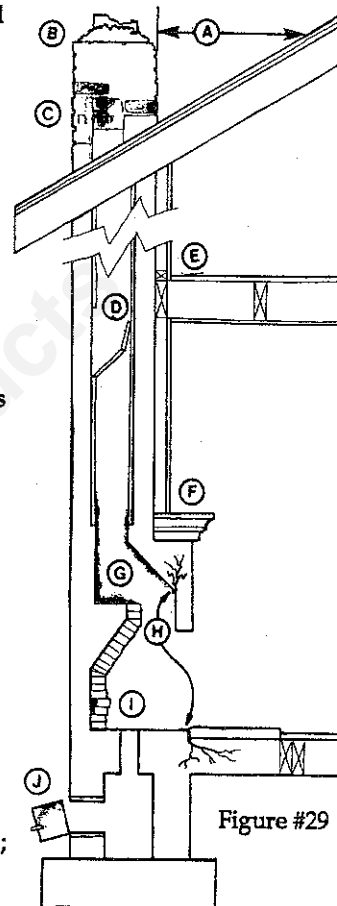

Figure #29

Existing masonry chimneys, especially older ones, may have two or more openings through the chimney walls to the same flue. The openings were used to connect stoves in different rooms to the chimney. The unused openings must be sealed with masonry to the thickness of the chimney wall. Unused openings sealed with pie plates or wallpaper are a hazard. In the event of a chimney fire, flames and smoke may be forced out of these unused thimbles.

DO NOT CONNECT YOUR STOVE OR INSERT TO A CHIMNEY FLUE SERVING ANOTHER APPLIANCE.

CHIMNEY SIZE

The Vermont Castings Intrepid II is designed to perform well when vented through flues which have these dimensions:

MASONRY:

- Square Liner 8" x 8" (nominal)
- Rectangular Liner 8" x 12" (nominal)
- Round Liner 6" or 8" (inside dimensions)

PREFABRICATED:

- Round Liner 6" or 8" (inside dimension)

Chimneys with liners larger than 8" x 12" may

experience rapid cooling of smoke and reduction in draft, especially if they are located outside the home. These large chimneys may need to be insulated or the flues re-lined for good stove performance. Vermont Castings offers chimney lining accessories to help make the connection between stainless steel chimney liners and our stoves and Fireplace Inserts.

Clearances

Your stove and chimney connector will radiate energy in all directions when in operation. An important part of planning a safe installation is to be sure combustible materials near your stove do not overheat due to inadequate clearance.

Clearance is the distance between your stove (or chimney connector) and nearby walls, ceiling, and floors, as well as other combustible materials. A considerable distance must also be maintained to moveable items, such as furniture, newspapers, or clothes left to dry near the stove; 48" is recommended. Installing your Intrepid II to the tested clearance and keeping those clearance areas empty assures that nearby surfaces and objects will not overheat.

Clearances must be large enough so even very dry wood near your stove will not overheat and catch fire. Wood that is part of a wall or floor will dry as it ages, and its ignition point (the temperature at which it will start to burn) will be lowered. The change may take place slowly over a period of many years, or more quickly if the wood is near a source of heat such as a wood stove.

Your Vermont Castings Intrepid II has been carefully and thoroughly tested by independent testing laboratories to determine safe clearances. During testing, heat sensors installed in all surfaces near the stove and chimney connector, including floors and ceilings, show the temperatures reached during a variety of combustion situations. Clearance distances are accepted only when the sensors show the stove is far enough from nearby surfaces to meet strict UL or ULC standards.

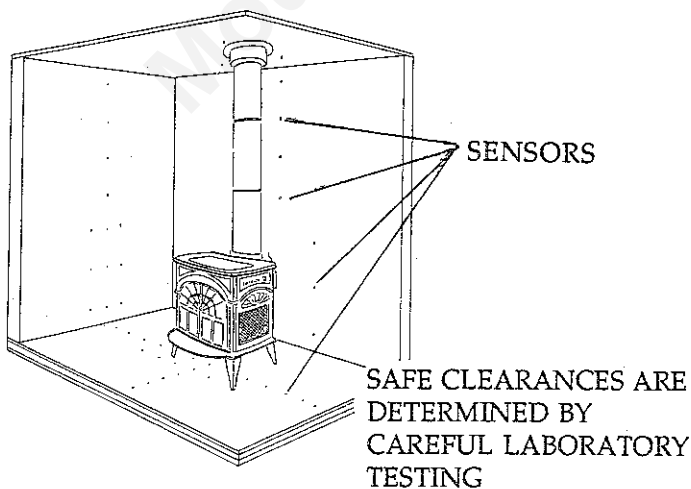

Figure #30

USING THE CLEARANCE CHART

Separate tests are done for parallel and corner installations, for installations using stove and chimney connector heat shields, and for installations using ventilated wall shields. If your stove will be parallel to the wall behind it (parallel installation), use the columns of the chart labelled "side" and "rear". If your stove will be installed in a corner (corner installation), use the columns labelled "corner". Your stove will be in either a parallel or a corner installation, not both. Use only the part of the chart that applies to your installation. Note: Side clearances do not apply to corner installations.

Measure clearance between the edge of the stove's top plate and the nearby combustible surface. For most common installations, when the stove has the proper clearance from nearby surfaces, the chimney connector

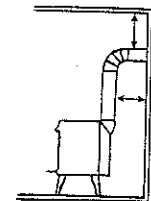
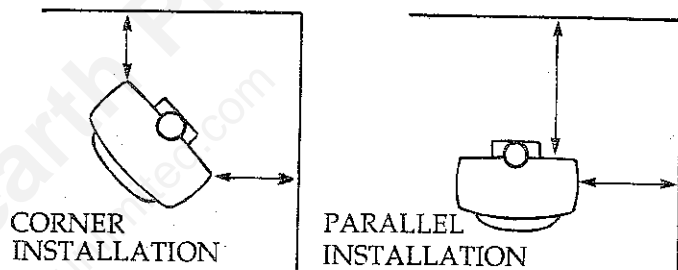

Figure #31



will also have the proper clearance. However, installations vary. It is important to double check all installations for proper chimney connector clearance, as well as stove clearance.

The clearance distance must be empty except for non-combustible heat shields. Air flowing between the stove (and/or chimney connector) and nearby shields carries away heat. Do not block the air flow by filling this empty space with any insulating material.

ALCOVE INSTALLATIONS

Because of their restricted air flow and heat retention characteristics, specific construction requirements and special clearances apply to installations into alcoves. Contact your Vermont Castings Authorized Dealer for instructions and specifications before beginning an alcove installation.

Clearance Reductions

When no shields are used, empty space alone provides protection against overheating. When shields are used, it is usually possible to reduce the required clearance, as the shields offer additional protection.

Shields may be attached directly to the stove and/or chimney connector, or they may be fitted to the nearby wall surfaces, or a variety of different type shields may be used together.

Intrepid® II Clearance Chart

STOVE CLEARANCE	Unprotected Surfaces			Protected Surfaces		
	PARALLEL INSTALLATION	CORNER INSTALLATION		PARALLEL INSTALLATION	CORNER INSTALLATION	
	Side	Rear	Corner	Side	Rear	Corner
No Heat Shields	24"	30"	20"	12"	16"	10"
Top Exit, Rear H.S. only ¹	24"	30"	20"	12"	16"	10"
Rear Exit, Rear H.S. only	24"	14"	N/A	12"	9"	N/A
Top Exit, Rear & Connector Shields ^{1,2}	24"	14"	12"	12"	9"	10"
CHIMNEY CONNECTOR CLEARANCE	ALL INSTALLATIONS			ALL INSTALLATIONS		
No Heat Shields				11"		
Connector Heat Shields				4" ³		
FRONT CLEARANCE TO COMBUSTIBLES	ALL INSTALLATIONS					
	48"					

¹Shielding for a top exit stove must include the stove rear heat shield insert to protect the area behind the flue collar.
²Chimney connector heat shields in an installation which goes through a combustible ceiling must extend to 1" below the ceiling heat shield, which is 22" in diameter. The ceiling shield should be 24 gauge or heavier sheetmetal, centered on the chimney pipe, and mounted on 1" non-combustible spacers.
³The ceiling heat shield required when chimney connector shields are used, should meet the wall protector. This will require trimming the ceiling shield along the line of intersection with the wall protector.

When shields are attached to the stove or chimney connector, they are mounted 1" - 2" away from the stove or connector surface on non-combustible spacers. The shiny shield surface facing the heat source must be left unpainted, enabling it to reflect heat back towards the stove or connector and away from the wall.

The greatest clearance reductions result from using both stove and chimney connector shields in conjunction with wall shields.

...WITH NO HEAT SHIELDS

If the Intrepid II is installed parallel to the rear wall (parallel installation) and no shields are used, the stove must be at least 30" from the wall behind it, and at least 24" from walls beside it.

If the Intrepid II is installed in a corner (corner installation) and no shields are used, the corners of the stove must be at least 20" from nearby walls.

Measure these distances from the edge of the top plate of the stove nearest the wall to the combustible part of the wall.

...WITH STOVE HEAT SHIELD ONLY

If you install an Intrepid II with a rear heat shield in a parallel installation, but use no chimney connector heat shields, different clearances will be required for top-exiting and rear-exiting stoves.

For top-exiting stoves, clearance to the rear wall is determined by heat from the unshielded chimney connector, not heat from the stove. Stove placement must ensure that the unshielded connector can not overheat the rear wall. Rear clearance measured from the chimney connector to the combustible component of the rear wall must be a minimum of 25". (Distance from the stove's top plate to the wall will be 30".)

Side clearance is determined by heat from the stove. It must be a minimum of 24", measured from the edge of the stove top to the combustible component of the unprotected wall.

For rear-exiting stoves, both rear and side clearances are determined by the heat from the stove (provided that the connector does not pass near a combustible surface).

The rear heat shield protects the wall behind the stove so that clearance may be reduced to 14", measured

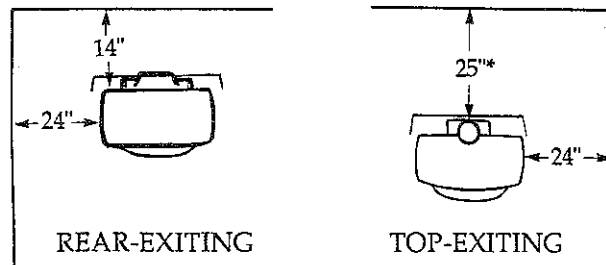
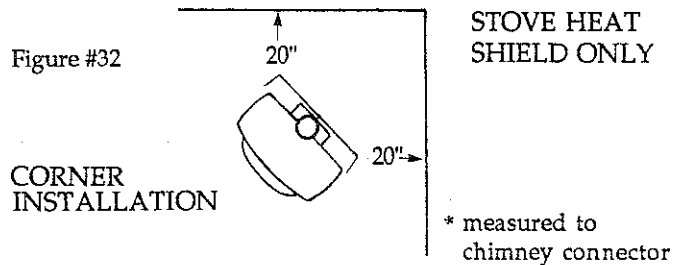

from the rear edge of the stove's top plate to the combustible part of the wall. Side clearance remains the same - 24", measured from the edge of the stove top to the side wall.

For corner installations, there is no reduction in the required clearance when using only a stove heat shield.

WALL SHIELD REQUIREMENTS FOR MINIMUM STOVE CLEARANCES
IN SOME COMMON INTREPID II INSTALLATIONS

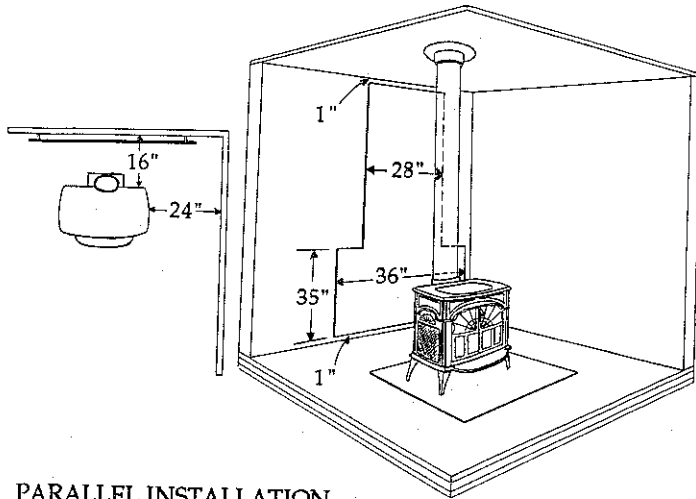

PARALLEL INSTALLATION
VERTICAL CHIMNEY CONNECTOR

Reduced rear wall clearance. The connector heat shield must be centered behind the connector.

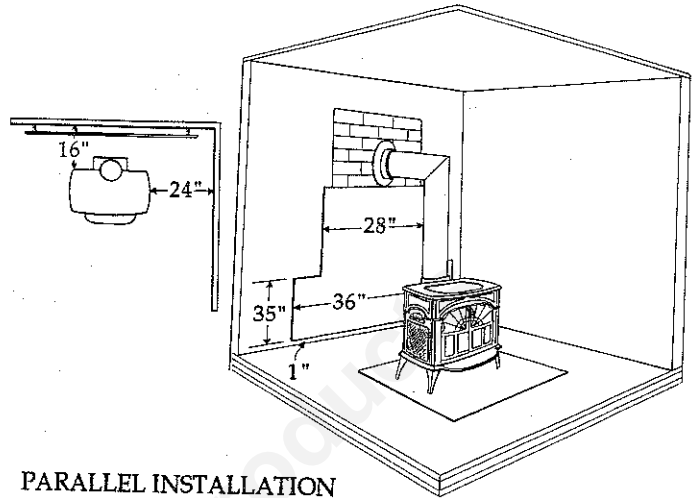

PARALLEL INSTALLATION
REAR WALL PASS-THROUGH

Reduced rear wall clearance.

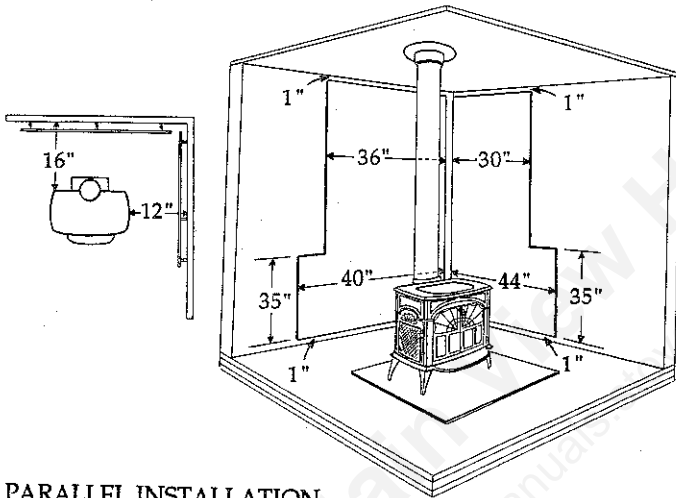

PARALLEL INSTALLATION
VERTICAL CHIMNEY CONNECTOR

Reduced rear and side wall clearances. Shields may meet at corner if desired.

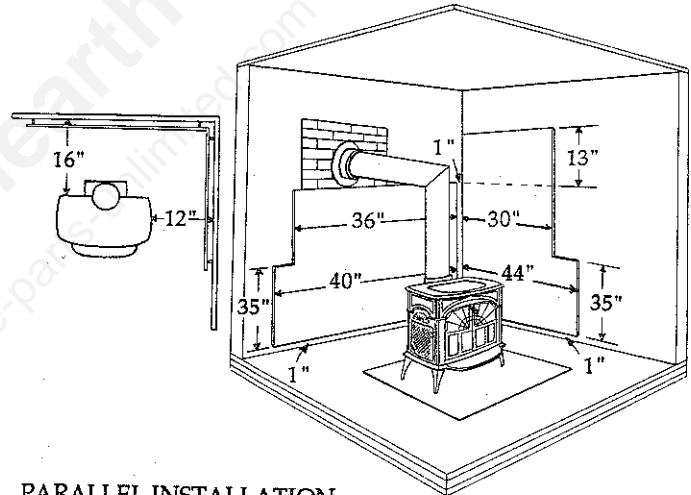

PARALLEL INSTALLATION
REAR WALL PASS-THROUGH

Reduced rear and side wall clearances. Shields may meet at corner if desired.

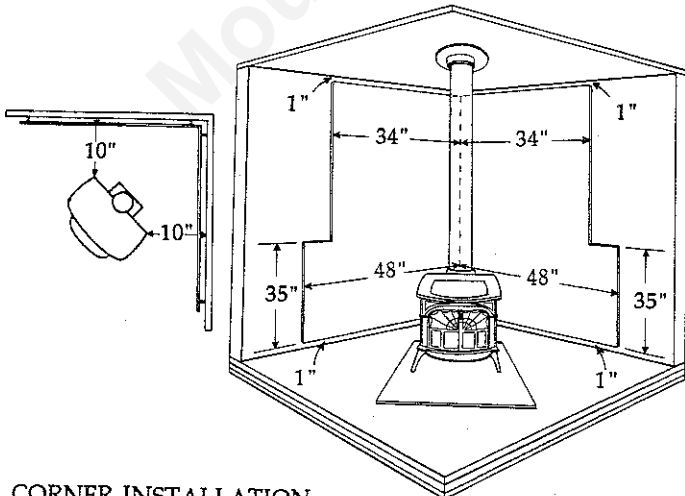

CORNER INSTALLATION
VERTICAL CHIMNEY CONNECTOR

Reduced side wall clearances. Shields must meet at corner.

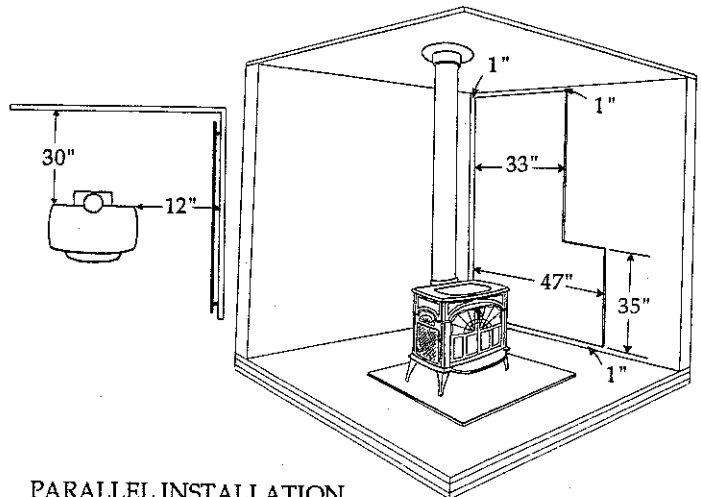

PARALLEL INSTALLATION
VERTICAL CHIMNEY CONNECTOR

Reduced side wall clearance.

...WITH CHIMNEY CONNECTOR HEAT SHIELDS ONLY

The Intrepid II listing is for installations using single-wall chimney connectors. The rows of the clearance chart labelled "Chimney Connector Clearance" give clearances measured from the chimney connector to nearby walls and ceilings. ("Ceilings" is underlined to remind you that ceiling clearance is an important clearance that is sometimes overlooked for horizontal runs of connector.) Be sure to double-check chimney connector clearances before completing your installation.

When installing chimney connectors for an Intrepid II installation in which the chimney connector is connected vertically to a prefabricated chimney system, the chimney connector heat shields must not extend to the ceiling. Instead, the connector shielding must stop 1" below a ceiling shield as shown below. As an alternative, extend the prefabricated chimney 22" down from the ceiling and make the transition to single-wall connector at that point.

Details of an Intrepid II installation into a prefabricated chimney with reduced clearance to a combustible wall.

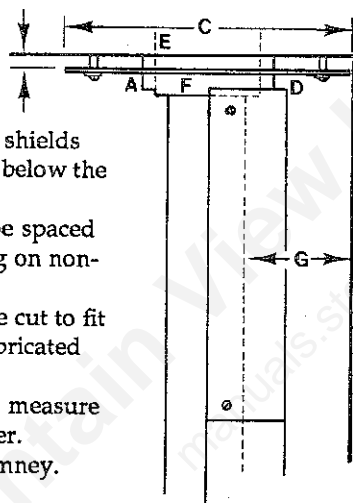

Figure #33

- A. Chimney connector heat shields must extend to exactly 1" below the ceiling shield.
- B. The ceiling shield must be spaced at least 1" from the ceiling on non-combustible spacers.
- C. The ceiling shield must be cut to fit closely around the prefabricated chimney.
- D. The ceiling shield should measure 22" x 22", or 22" in diameter.
- E. Listed, prefabricated chimney.
- F. Trim collar.
- G. See the Intrepid II Clearance Chart for minimum clearances applicable to your individual installation.

reduced clearances in some of the more common installations.

Wall shields should be constructed of 24 gauge or heavier sheetmetal, 1/2" noncombustible insulation board, or common brick laid on flat (3-1/2" side down). Shields must be spaced out from the combustible wall or ceiling 1" on noncombustible spacers. The spacers should not be directly behind the stove or chimney connector.

Air must be able to flow between the wall and the shield. At least one-half (50%) of the bottom 1" of the shield should be open and the shield must be open at the top. Protect the top opening with metal screening to prevent objects from falling behind the shield.

The shield for the stove must extend 10" above the top of the stove. The shield for the chimney connector must be 28" wide, centered behind the pipe, and stop 1" from the ceiling.

METAL LATH ON
NON-COMBUSTIBLE SPACERS

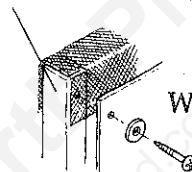

WALL SHIELD

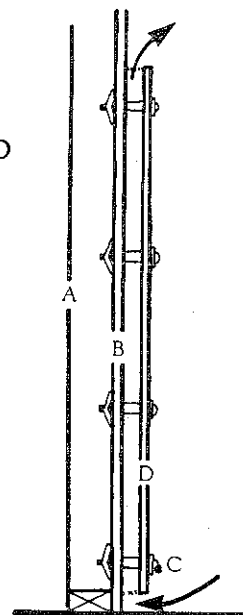

Figure #34

- A. STUD WALL FRAMING
- B. SHEETROCK
- C. SCREWS AND NON-COMBUSTIBLE SPACERS
- D. WALL SHIELD

Floor Protection

FREE-STANDING INSTALLATIONS

A stove installed on a combustible floor must first be placed on a non-combustible floor protector. Every floor, with the exception of bare concrete over earth, should be considered combustible. The floor protector is necessary to guard against spilled coals and embers, and in some installations, to protect against heat radiating from the bottom and front of the stove. Commonly used floor protector materials such as brick and stone may be good spark protectors but not good heat protectors. When using a custom-made floor protector it is often necessary to add a bottom heat shield to the stove to provide proper heat protection.

Spark protection must also be provided under the full length of any horizontal run of chimney connector.

...WITH STOVE AND CHIMNEY CONNECTOR HEAT SHIELDS

Use of both stove and chimney connector heat shields reduces the required clearance further as shown on line 4 of the clearance chart.

...WITH WALL SHIELDS

A properly constructed wall shield may be used to transform a standard wall into a protected wall, allowing installation to the clearances on the right half of the Clearance Chart. The diagrams on page 22 show correct placement and size of wall shields required for

For the 6" connector used with the Intrepid II, the protector must be a minimum of 10" wide, centered under the connector.

The type of floor protector required will depend upon the length of the legs used with the stove, and whether or not a bottom heat shield is installed.

STANDARD LEGS WITH HEAT SHIELD: With the standard 7" legs and a bottom heat shield in place, the floor protector serves only as a spark and ember barrier, and may consist of any non-combustible material, with the minimum hearth dimensions of 34" x 43". When using brick, tile, or stone, individual pieces must be mortared so sparks cannot fall through.

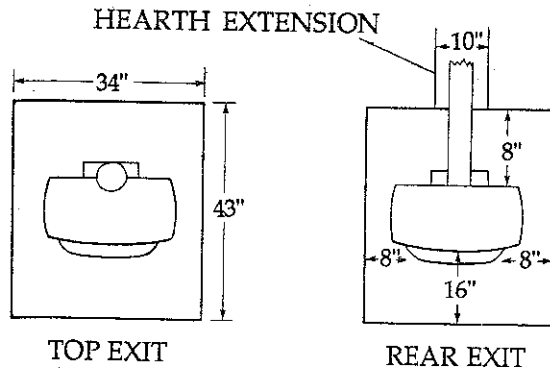

Figure #35

STANDARD LEGS WITHOUT HEAT SHIELD: Using the 7" legs without a bottom heat shield, the floor protector must also serve as a heat barrier. During laboratory testing, the necessary floor protector for this type of installation was determined to consist of a layer of 1/2" mineral board (such as WonderBoard or Durock) covered with a piece of sheetmetal measuring 34" wide x 43".

In this type of installation, a floor protector may be custom made if care is taken to ensure that it offers protection equivalent to the tested standard. To

determine equivalency, you must first know the thermal conductivity of the material you will use. Thermal conductivity, or "k", is a measure of how quickly heat will pass through a given material to combustible material underneath, described in the technical units of (btu)(in)/(ft)(hr)(F°). The "k" value for the Intrepid II's tested standard (mineral board) is 0.84. Custom made substitutes for the mineral board must provide the same protection as a 1/2" thickness of mineral board, ensuring that heat transfer occurs at the same speed or more slowly than the standard. The sample calculation at the bottom of the page details how to use a material's "k" factor to determine the thickness necessary for adequate protection.

You may also choose a tested and listed floor protector, at least 1/2" thick, of k value 0.84 or less. Your local Vermont Castings Authorized Dealer can help you assess the floor protector possibilities for your Intrepid II installation.

We recommend always using a bottom heat shield with regular legs, so that your floor protector acts only as a spark and ember barrier.

SHORT LEGS: The use of short legs is restricted to fireplace installations as detailed in the next section.

FIREPLACE INSTALLATIONS

In many fireplaces the brick or concrete hearth in front of the fireplace opening is supported by heavy wooden framing. Bricks and concrete are not good insulators, so heat radiated to the hearth under the stove will pass through the hearth directly to the wooden framing. Such fireplace hearths must be protected like any other combustible floor.

STANDARD LEGS: If a bottom heat shield is used, the existing fireplace hearth may provide adequate spark and falling ember protections if it meets the necessary size requirement of 34 x 43". Without a bottom

CALCULATION FOR THICKNESS OF AN ALTERNATE HEARTH EXTENSION MATERIAL WHEN USING REGULAR LEGS AND NO BOTTOM HEAT SHIELD

To calculate the thickness of an alternate material necessary to provide the required protection, obtain its k factor (available from a code or building materials handbook) and then use the following formula:

$$\frac{(\text{k factor of alternate material}) \times (\text{Thickness of WonderBoard required})}{(\text{k factor of WonderBoard})} = \text{Required thickness of alternate material}$$

A commonly used material, brick, provides an example. The k factor for brick is 5.0.

$$\frac{5.0 \times (1/2")}{0.84} = 3.0"$$

That is, when using brick for the floor protector, the brick must be a minimum of 3.0" thick. Similar calculations may be performed for any noncombustible material provided its k factor is known. NOTE: The piece of sheetmetal required in the tested standard must also be used. It may be positioned under the brick or other equivalent material. If you have questions about floor protectors, contact your local Vermont Castings Authorized Dealer.

heat shield, the hearth construction must meet the guidelines outline in the previous section.

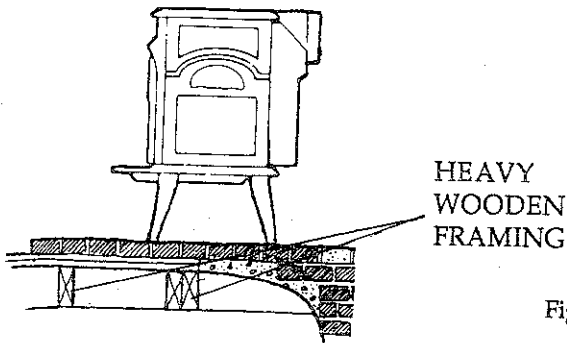

Figure #36

SHORT LEGS WITH BOTTOM HEAT SHIELD: A short leg option is available for use in fireplace installations only. These 3" legs must be used in conjunction with a bottom heat shield. The fireplace itself must be constructed in accordance with the guidelines outlined in the National Fire Protections Association 211 standard. The fireplace must have a hearth extension which extends a minimum of 16" in front of the fireplace face; it must be constructed of brick, concrete, or other non-combustible material properly supported and with no combustible material against the underside. The stove must sit entirely over this hearth extension. The area in front of the stove must be further protected against falling sparks and embers for an additional 16".

Special Installations

FIREPLACE MANTEL AND TRIM SHIELDS

If your installation will utilize an existing fireplace and its masonry chimney built to code, you must check your fireplace mantel and trim clearances. Ventilated shields (non-combustible shields installed on non-combustible spacers 1" away from the combustible surface) may be used to reduce clearances as shown in Table # 2. Mantel and top trim shields for the Intrepid II must be at least 48" long, centered over the stove; side trim shields must extend the full length of the trim.

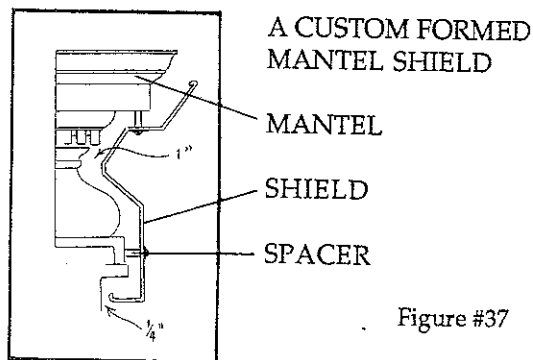
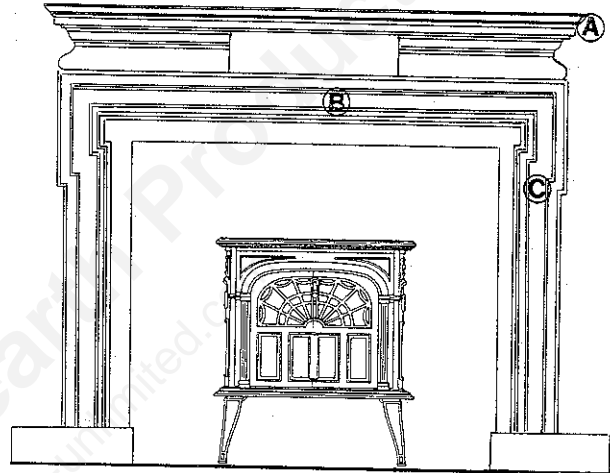

Figure #37

Refer to the figure below. An unprotected mantel (A) must have a minimum clearance of 30", measured from the stove's top plate; with a ventilated shield the clearance may safely be reduced to 14".

Unprotected top trim (B) protruding 2" or more from the face of the fireplace must be a minimum of 24" from the stove's top surface; with a ventilated trim shield the clearance may be safely reduced to 14".

Unprotected side trim (C) which protrudes 2" or more from the face of the fireplace must have a minimum 15" of clearance, measured from the stove's top side edge; with a ventilated trim shield, the clearance may be safely reduced to 10".



	UNPROTECTED	PROTECTED
A. Mantel	30"	14"
B. Top Trim	24"	14"
C. Side Trim	15"	10"

WALL PASS-THROUGHS

Whenever possible, design your installation so that the connector does not pass through a combustible wall. If you are considering a wall-pass through in your installation, be sure you check with your building inspector before you begin, and check with the chimney connector manufacturer for any specific requirements.

Accessories are available for use as wall pass-throughs. If using one of these, make sure it has been tested and listed for use as a wall pass-through.

The National Fire Protection Association (NFPA) has established guidelines for passing chimney connectors through combustible walls. Many building code inspectors follow these guidelines when approving installations.

The illustration shows one NFPA recommended method, in which all combustible material in the wall is cut away from the single wall connector a sufficient distance to provide the required 12" clearance for the

connector. Any material used to close up the opening must be non-combustible.

AN APPROVED WALL PASS-THROUGH

CHIMNEY CONNECTOR

WALL STUD

12" OF NON-COMBUSTIBLE MATERIAL

FLOOR PROTECTOR

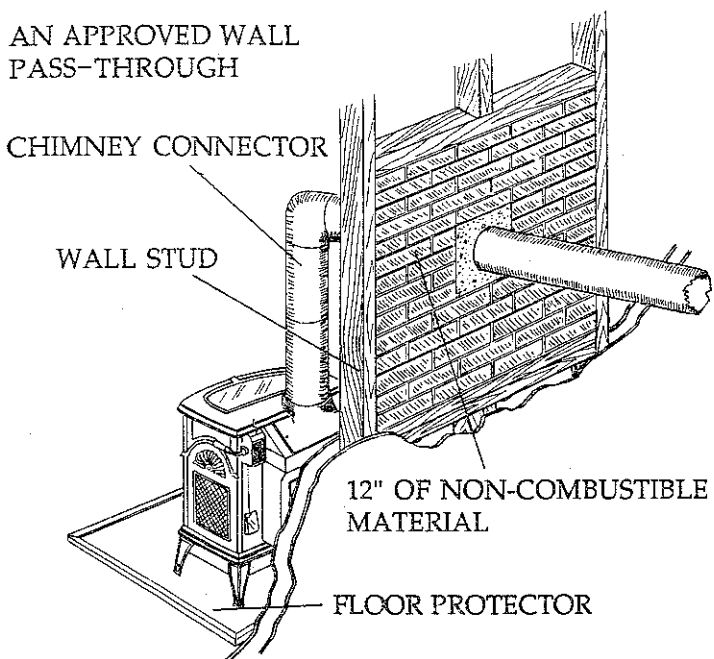

Figure #39

Three other methods are also approved by the NFPA. These are: 1. Using a section of double-wall chimney with a nine-inch clearance to combustibles; 2. Placing a chimney connector pipe inside a ventilated thimble, which is then separated from combustibles by six inches of fiberglass insulating material; and 3. Placing a chimney connector pipe inside a section of eight-inch diameter solid insulated factory-built chimney, with two inches of airspace between the chimney section and combustibles.

Chimney Connectors

The chimney connector should be made of 24 gauge or heavier sheetmetal, and should be 6" in diameter. Galvanized chimney connector should not be used. When exposed to temperatures reached by smoke and exhaust gases, galvanized pipe may release toxic fumes.

The chimney connector should be as short and direct as possible, with no more than two 90 degree turns.

Horizontal runs of chimney connectors should slope upward 1/4" per foot going from the stove toward the chimney. The recommended maximum length of a horizontal run is 3 feet. The total length of chimney connector should be no longer than 8 feet. In cathedral ceiling installations, a prefabricated chimney should be brought down to within 8 feet of the stove. The whole chimney connector should be exposed and accessible for inspection and cleaning.

Do not pass the chimney connector through a combustible wall if it can be avoided. If this cannot be avoided, follow the recommendations in the section on Wall Pass-Throughs. Never pass a chimney connector through a combustible ceiling.

Codes and Listings

Conforming to local building codes will be an important part of your planning. Local authorities make the final decision on whether or not an installation will be approved. They need to know that your installation is safe and meets local and state codes.

The metal label permanently attached to the back of every Vermont Castings stove indicates that the stove has been tested to current UL standards, and gives the name of the testing laboratory. Clearance and installation information is also printed on the label. In most cases, local authorities will accept the label as evidence that, when the stove is installed according to the information on the label and in this manual, the installation meets codes and can be approved.

However, codes vary in different areas. Be sure to review your installation plans with your local authority before starting the installation. Check with your local Vermont Castings Authorized Dealer for help in providing the necessary information to local officials.

This manual will answer clearance and construction questions for almost all installations. Your local Vermont Castings Authorized Dealer will also be able to help. For questions left unanswered, we recommend that you refer to the National Fire Protection Association ANSI/NFPA 211-1988 Standard for Chimneys, Fireplaces, Vents and Solid Fuel Burning Appliances. This standard is the basis for many national codes. It is nationally recognized, and is accepted by most local authorities. Your local Vermont Castings Authorized Dealer, or your local building official may have a copy.

Remember, your local building official makes the final decision on approvals of installations.

WARNING:

DO NOT USE DOUBLE-WALL CHIMNEY CONNECTORS WITH THE INTREPID® II, UNLESS THEY HAVE BEEN SPECIFICALLY TESTED AND LISTED FOR USE WITH THIS APPLIANCE. USE OF DOUBLE-WALL CHIMNEY CONNECTORS WHICH HAVE NOT BEEN TESTED AND LISTED FOR USE WITH THE INTREPID® II MAY RESULT IN TEMPERATURES EXCEEDING THE LIMITS ESTABLISHED BY THE TEST STANDARD ANSI/UL-1482. A POTENTIAL HAZARD MAY RESULT, INCLUDING A HOUSE FIRE.

SEE YOUR VERMONT CASTINGS AUTHORIZED DEALER FOR INFORMATION ON DOUBLE-WALL CONNECTORS WHICH HAVE BEEN SUCCESSFULLY TESTED AND LISTED FOR USE WITH THE INTREPID® II.

Installation Procedures

Before you begin, review your plans to see that:

- Your stove and chimney connector will be far enough from combustible material to meet all clearance requirements.
- The floor protector is large enough and constructed properly to meet all requirements.
- You have all necessary permits from local authorities.

IMPORTANT: Failure to follow these installation instructions may result in a dangerous situation, including a chimney or house fire. Follow all instructions exactly.

SET UP YOUR STOVE

Cast iron stoves are heavy. Have the assistance of at least one other person as you move your stove into position.

Use soap and warm water to wash the protective coating of oil from the griddle. Dry the griddle thoroughly.

Install the legs (and optional bottom heat shield) according to the instructions included with those parts. Leg bolts and washers are included in the hardware package found in your stove.

The removable insert handle is used to open or close the front doors, or to change the position of the damper. After it has been used, it is removed so it won't get hot. It may be stored in the handle holder installed behind the right leg.

The flue collar may be reversed by removing the two screws which attach the collar to the back of the stove. Be sure the gasketing around the flue collar opening is in position when you screw the collar back onto the stove.

The Chimney Connector

SAFETY NOTE: Always wear gloves and safety goggles when drilling, cutting or joining sections of chimney connector.

ASSEMBLY

- Assemble the chimney connector beginning at the flue collar of the stove, keeping the crimped ends towards the stove. Using the holes in the flue collar as guides, drill 1/8" holes in the bottom of the first section of chimney connector, and secure it to the flue collar with three #10 x 1/2" sheetmetal screws.
- Align the seams of the individual sections. Secure each joint between sections of chimney connector, including telescoping joints, with at least three sheetmetal screws. The pre-drilled holes in the top of each section of Vermont Castings Chimney Connector serve as guides when you drill 1/8" holes in the bottom of the next section.
- Secure the chimney connector to the chimney. Instructions for various installations follow.

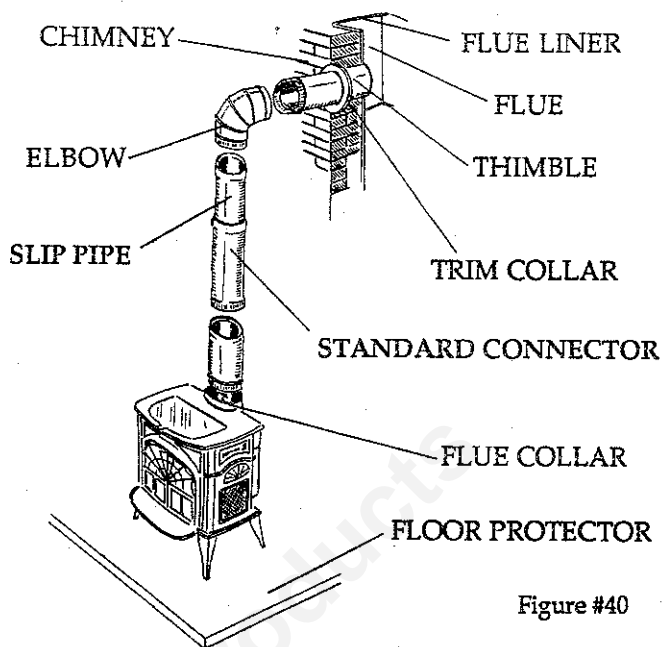

Figure #40

- Be sure the installed stove and chimney connector are correct distances from nearby combustible material.

Note: Vermont Castings offers Slip Pipes and Thimble Sleeves which can be used to form telescoping joints between sections of chimney connector. When telescoping joints are used, it is often unnecessary to cut individual sections of connector.

SECURING THE CONNECTOR

...TO A PREFABRICATED CHIMNEY

Follow the installation instructions of the chimney manufacturer exactly as you install the chimney. The manufacturer of the chimney will supply the accessories to support the chimney, either from the roof of the house or at the ceiling of the room where the stove is installed.

The connection between the prefabricated chimney and the chimney connector can be made with the Vermont Castings Enamel-to-Prefab Connector. This accessory is used with both black and enamel chimney

CHIMNEY SUPPORTED AT CEILING

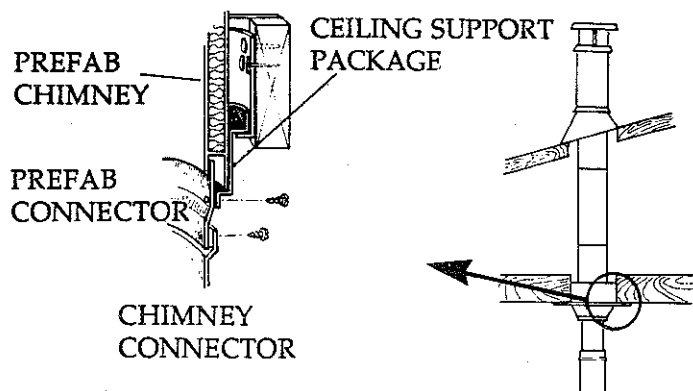

Figure #41

connectors. The top of the connector attaches directly to the chimney or to the chimney's ceiling support package. The bottom of the connector is screwed to the chimney connector.

The connector is designed so the top end will fit outside the inner wall of the chimney, and the bottom end will fit inside the first section of chimney connector. In this way, any soot or creosote falling from the inner walls of the chimney will stay inside the chimney connector.

...TO A MASONRY CHIMNEY

Both freestanding masonry chimneys and fireplace masonry chimneys may be used for installation of your Intrepid II.

FREESTANDING: If the chimney connector must pass through a combustible wall to reach the chimney, follow the recommendations in the Wall Pass-Through section.

The opening through the chimney wall to the flue (the "breach") must be lined with either a ceramic or metal cylinder, called the "thimble", which is securely cemented in place. Most chimney breeches incorporate thimbles, but check to be sure the fit is snug and the joint between thimble and chimney wall firmly cemented.

A Vermont Castings Thimble Sleeve will facilitate the removal of the chimney connector system for inspection and cleaning. The Thimble Sleeve is slightly smaller in diameter than standard connector pipe and most thimbles. Slide the Thimble Sleeve into the breach until it is flush with the inner flue wall.

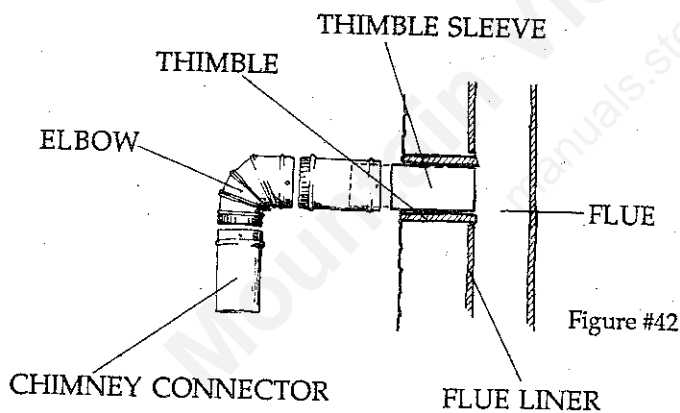

(Don't extend it into the actual flue passage, as this can interfere with proper draft.) The Thimble Sleeve should protrude 1" - 2" into the room. Use furnace cement and thin gasketing to seal the Sleeve in place in the thimble. Secure the chimney connector to the outer end of the Sleeve with sheetmetal screws.

Lacking a thimble, a suitable length of chimney connector can be extended through the breach to the inner face of the flue liner, and securely cemented in place. Additional pieces of connector are then attached with sheetmetal screws.

FIREPLACE - ABOVE THE FIREPLACE: In this installation, the chimney connector goes up from the

stove, turns 90 degrees, and goes back into the fireplace chimney. The liner of the fireplace chimney should extend at least to the point at which the chimney connector enters the chimney. Follow all the guidelines for installing a chimney connector into a freestanding masonry chimney, and watch these additional points:

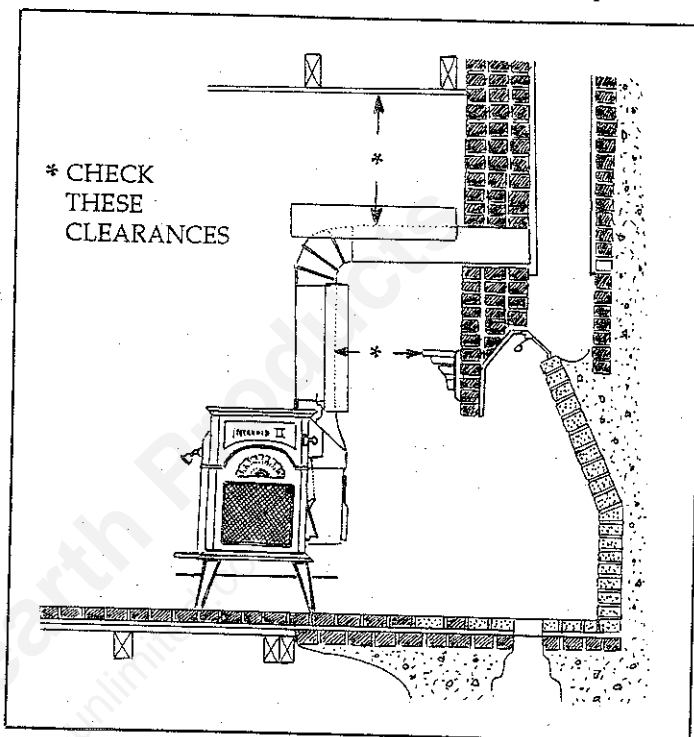

- If there is a combustible mantel or trim, check the stove and chimney connector clearances. Use the necessary combination of mantel, trim, and connector heat shields to provide the required clearances.
- Double check connector clearance from the ceiling.
- The fireplace damper must be closed and sealed to prevent room air from being drawn up the flue, reducing the draft. However, it must be possible to re-open the damper to inspect or clean the chimney.

FIREPLACE - THROUGH THE FIREPLACE: When installed through a fireplace opening, the chimney connector goes back from the stove, enters the fireplace cavity, turns upward, and passes through the fireplace damper opening and smoke chamber, and finally to the chimney flue. Watch these points:

- If there is a combustible mantel or trim, check the stove and chimney connector clearances. Use the necessary combination of mantel, trim, and connector heat shields to provide the required clearances.
- When passing the chimney connector through the damper opening it may be necessary to "ovalize" the connector pipe. Do not make the narrowest width less than 4-1/2".
- The damper should be removed if possible, or sealed in the open position if removal is impossible.
- A seal must be provided so that room air is not drawn into the fireplace and up the chimney, reducing draft. The Vermont Castings Flex Connector System provides a convenient method for making the required

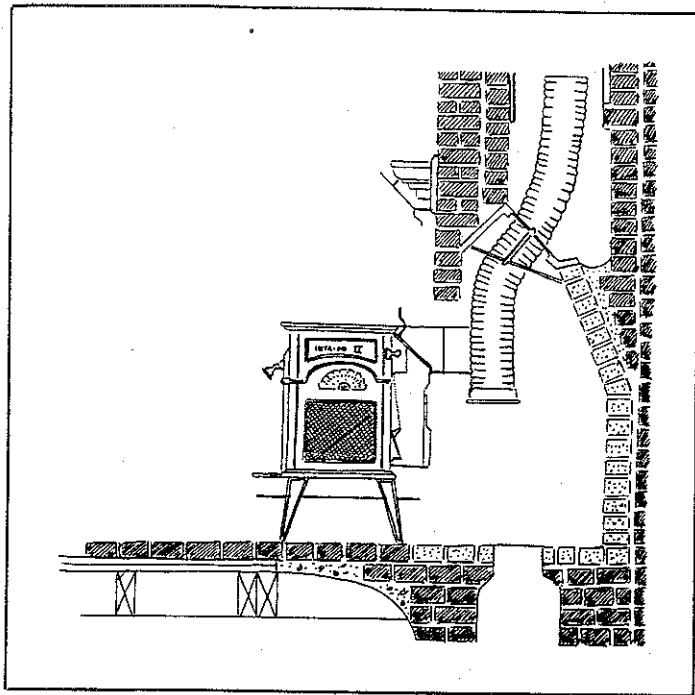

seal and offers a flexible stainless steel chimney connector which can be bent to allow passage through most narrow damper openings.

NOTE: Do not vent your Vermont Castings stove into a factory-built (zero-clearance) fireplace. Zero-clearance fireplaces and their chimneys are specifically designed as a unit for use as fireplaces. It may void the listing or be hazardous to adapt them for any other use.

Safety Tips

Do not overfire your stove. If a cast iron part or the chimney connector glows red, you are overfiring. If overfiring occurs, adjust the thermostat lever to decrease the air and slow the fire. If at any time it becomes difficult to slow or regulate the fire in a reasonable time, let the fire go out. Overfiring or difficulty in slowing the fire is the result of too much air entering the stove. Check these points:

1. Does the air shutter close when you move the thermostat lever to the right?
2. Is the gasketing in good shape so air does not leak into the stove around the doors, griddle and flue collar?
3. Is the door handle adjusted so the doors close tightly? Instructions for adjusting the handle are given in the Maintenance Section.

If the draft in the chimney is interrupted, smoke, which contains carbon monoxide and other toxic gases, may be forced out of the stove and chimney and into the living areas. This is a potentially hazardous condition. If you notice an acrid smell or if smoke backs out of the stove frequently, let the fire go out. Be sure all air inlets are clear, the chimney connector and chimney are clean, and your stove is being operated correctly before starting another fire. The following suggestions may help solve draft related problems:

1. When your heating needs are light and you are operating your stove to produce a small amount of heat, in Spring and Fall for instance, small, hot fires work best.
2. If you notice draft problems when the wind is blowing, consider installing a chimney cap designed to stabilize draft under windy conditions.

Keep all safety equipment ready for use:

1. Test smoke alarm to be sure it is operating properly.
2. Be sure the fire extinguisher works and is clearly visible. All occupants of the house should know where it is, and how it operates.
3. Have heavy stove gloves available near the stove.
4. Have special safety accessories (e.g., Child Guard Screen) available for use if small children will be in the home.

In case of a chimney fire:

1. Close the damper and thermostat lever.
2. Get people out of the house.
3. Call the Fire Department.

Checklist

UNDER THE STOVE

Combustible material under the stove must be protected from heat from the bottom of the stove and from falling sparks and embers. All floors should be considered combustible with the exception of a bare cement basement floor with nothing but dirt underneath.

*Floor protector size and construction information starts on page 23.

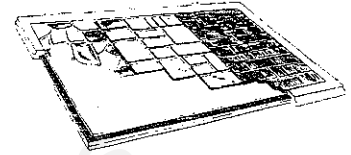

BEHIND AND BESIDE THE STOVE

Combustible material behind and beside the stove must be protected from radiant heat from the stove and chimney connector. Protection is provided by clearance (empty space) or shields, or both. Protection requirements depend on how close the stove will be to combustible material, and whether the stove is in the top exit or rear exit configuration.

*This information starts on page 20.

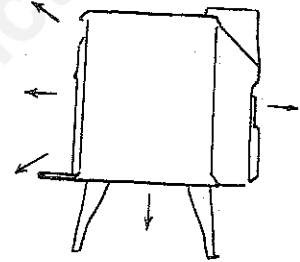

NEAR THE CHIMNEY CONNECTOR

Combustible material near single-wall chimney connectors must be protected from radiant heat from the chimney connector. Although the clearance charts give minimum clearances which consider both stove and chimney connector in most standard installations, double check connector clearances. This is especially important where the connector has horizontal or vertical runs which may make it pass near combustible material.

*This information starts on page 20.

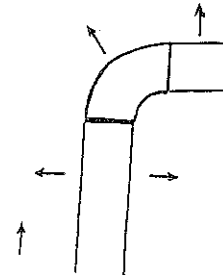

ABOVE THE STOVE AND CHIMNEY CONNECTOR

Combustible material above the stove and chimney connector must be protected. A combustible fireplace mantel may need protection. A ceiling above a horizontal run of chimney connector may need protection.

*This information is found in the chart on page 21.

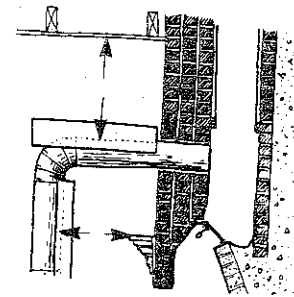

CHIMNEY THROUGH THE CEILING

Where a chimney passes through a roof or ceiling, clearance must be provided. Most prefabricated metal chimneys must be kept at least 2" from combustible material. Check with the manufacturer of the chimney. According to the NFPA, the minimum air space between interior masonry chimneys (any part of the chimney is within the house) and combustible material is 2". The minimum air space between exterior masonry chimneys (the chimney is completely outside the house) and combustible materials is 1". Check with your local building official.

CHIMNEY CONNECTOR THROUGH THE WALL

A chimney connector (the single wall stovepipe which connects your stove to the chimney) must not pass through floor or ceiling. If properly installed, the connector may pass through a combustible wall.

*This information is on page 25.

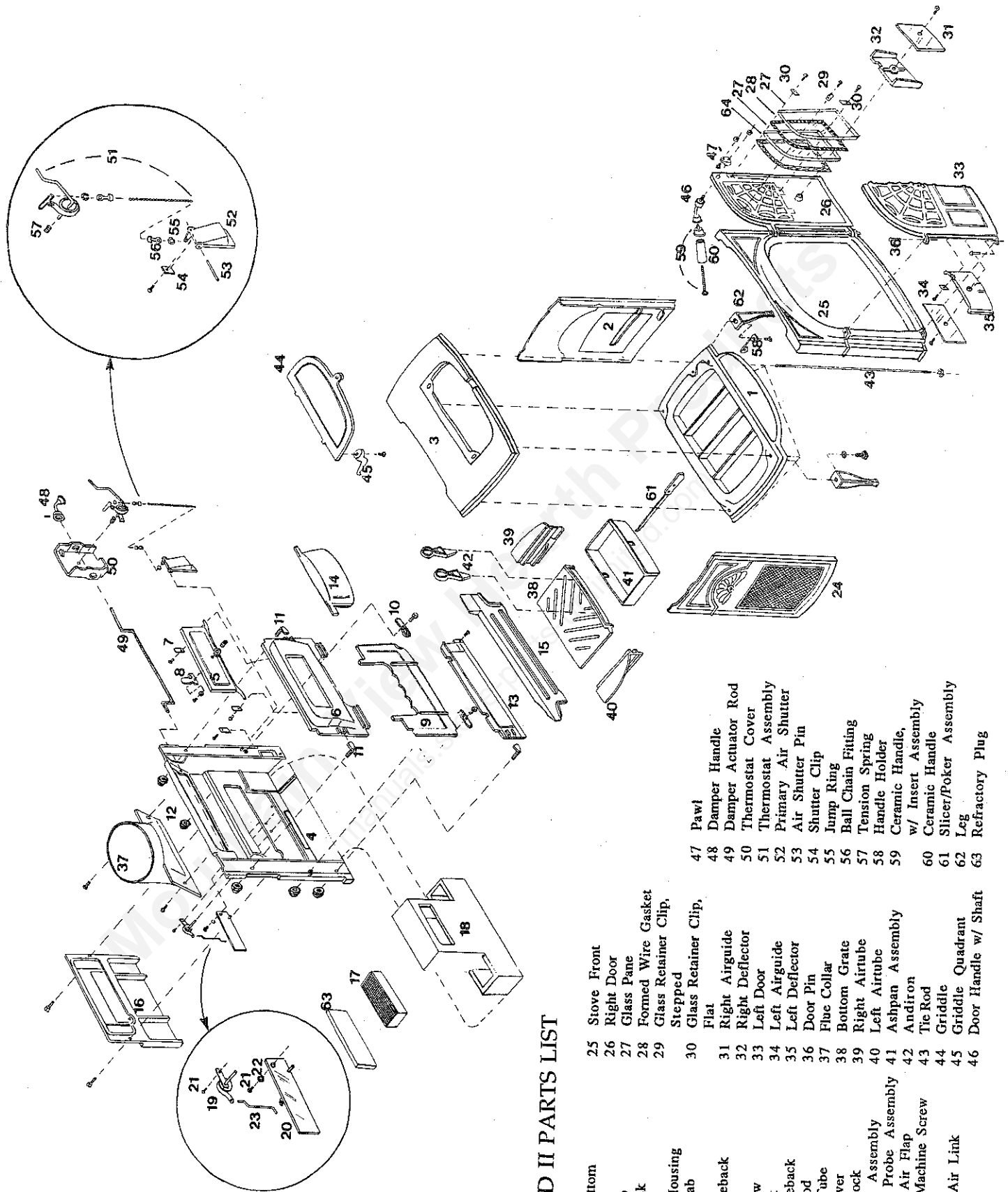

INTREPID II PARTS LIST

- | | |
|---------------------------------|---------------------------------------|
| 1 Stove Bottom | 47 Pawl |
| 2 Right End | 48 Damper Handle |
| 3 Stove Top | 49 Damper Actuator Rod |
| 4 Stove Back | 50 Thermostat Cover |
| 5 Damper Housing | 51 Thermostat Assembly |
| 6 Damper Tab | 52 Primary Air Shutter |
| 7 D-Plate | 53 Air Shutter Pin |
| 8 Upper Fireback | 54 Shutter Clip |
| 9 Clamp | 55 Jump Ring |
| 10 Weld Screw | 56 Ball Chain Fitting |
| 11 Acorn Nut | 57 Tension Spring |
| 12 Lower Fireback | 58 Handle Holder |
| 13 Throat Hood | 59 Ceramic Handle, w/ Insert Assembly |
| 14 Rear Air Tube | 60 Ceramic Handle |
| 15 Access Cover | 61 Slicer/Poker Assembly |
| 16 Catalyst Block | 62 Leg |
| 17 Refractory Assembly | 63 Refractory Plug |
| 18 Secondary Air Flap | |
| 19 Pan Head Machine Screw | |
| 20 Shim Ring | |
| 21 Secondary Air Link | |
| 22 Left End | |
| 23 Right End | |
| 24 Stove Front | |
| 25 Right Door | |
| 26 Glass Pane | |
| 27 Formed Wire Gasket | |
| 28 Glass Retainer Clip, Stepped | |
| 29 Glass Retainer Clip, Flat | |
| 30 Right Airguide | |
| 31 Right Deflector | |
| 32 Left Door | |
| 33 Left Airguide | |
| 34 Left Deflector | |
| 35 Door Pin | |
| 36 Flue Collar | |
| 37 Bottom Grate | |
| 38 Right Airtube | |
| 39 Left Airtube | |
| 40 Ashpan Assembly | |
| 41 Andiron | |
| 42 Tie Rod | |
| 43 Griddle | |
| 44 Griddle Quadrant | |
| 45 Door Handle w/ Shaft | |

APPENDIX - CATALYTIC COMBUSTORS

In any chemical reaction, including the combustion process, there are certain conditions which must be met before the reaction can take place. For example, a reaction may require a certain temperature, or a certain concentration of the reactants (the combustion gases and oxygen), or a certain amount of time. Catalysts, though not changed themselves during the reaction, have the ability to act at a molecular level to change these requirements. In the secondary combustion chamber of the Intrepid II, the catalyst reduces the temperature at which secondary combustion can occur from the 1000° F. - 1200° F. (540 C - 650 C) range to the 500° F. - 600° F. (260 C - 315 C) range, increasing efficiency, and reducing creosote and emissions.

The catalytic reaction, though advantageous, does have some limitations of its own. Primary among these is that the reactants (the gases) come into close physical contact with the catalyst itself. To ensure the necessary contact, the catalytic element in your Intrepid II is composed of a ceramic base in the shape of a honeycomb. On each of the honeycomb's many surfaces a coating of the catalyst (usually a noble metal such as platinum or palladium) is applied. The large surface area exposed in this configuration ensures that the combustion gases have the greatest opportunity to come in contact with the catalyst.

Loss of catalytic activity will be apparent in several ways. First you may notice an increase in fuel consumption. Second, there will be a visible increase in the rate at which creosote builds up in your chimney system. You may also notice a heavy discharge of smoke from the chimney and a reduction in draft strength. There are a number of catalytic problems which can cause loss of activity:

BLOCKAGE: While the honeycomb pattern ensures good contact, it also increases the resistance to flow of the combustion gases, and, because of the many surfaces, provides more places for creosote and fly ash to deposit. It is important to follow the operating instructions in order to minimize these deposits, and to

periodically inspect your catalyst for signs of blockage.

MASKING OR POISONING: While the catalyst itself does not enter into the combustion process, it is possible for certain elements, such as lead and sulfur, to attach to the active sites on the surface of the honeycomb. Though the catalyst is still there, it is covered, or masked, by the contaminant, and cannot function. To avoid this situation, it is important not to burn anything in your Intrepid II which is a source of these contaminants. Particularly avoid painted or treated wood, coal, household trash, colored papers, metal foils, or plastics. Chemical chimney cleaners may also contain harmful elements. The safest approach is to burn only untreated, natural wood.

FLAME IMPINGEMENT: The catalytic element is not designed for exposure to direct flame. If you continually overfire your Intrepid II, the chemistry of the catalytic coating may be altered, inhibiting the combustion process. Thermal degradation of the ceramic base may also occur, causing the element to disintegrate. Stay within the recommended guidelines in the Operation section of the Owner's Guide.

MECHANICAL DAMAGE: If the element is mishandled, damage may occur. Always treat the element carefully. Remember the catalyst is made of a ceramic material; treat it as you would fine china. Hairline cracks will not affect the performance of the catalyst, as long as the steel sleeve holds the element in the proper position.

PEELING: Peeling of the surface coat may occur if the catalytic element is frequently subjected to excessive temperatures. Follow the operating instructions carefully to avoid this type of damage.

Every Vermont Castings product is equipped with either a Corning Catalytic Combustor, or an element manufactured by Technical Glass Products. The products are equivalent. If for any reason you must ship your catalytic element, remember its fragile nature. Place the element in a plastic bag, and package it with a generous amount of shock absorbing material.

WARRANTY - FOR USE IN THE U.S.A. LIMITED 3 YEAR WARRANTY

Vermont Castings, Inc. warrants that this Intrepid® II will be free of defects in material and workmanship for a period of three years from the date you receive it, except that the catalyst, thermostat assembly, handles, glass door panels, cement, and gasketing shall be warranted as described below.

Vermont Castings, Inc. will repair or replace, at its option, any part found to be defective when the Intrepid® II is returned with shipping charges prepaid to a Vermont Castings Authorized Dealer. The customer must pay for any Authorized Dealer in-home travel fees, service charges, or transportation costs for returning the stove to the Authorized Dealer. If upon inspection, the damage is found to be the fault of the manufacturer, repairs will be authorized at no charge to the customer for parts and/or labor.

Any Intrepid® II or part thereof that is repaired or replaced during the limited warranty period will be warranted under the terms of the limited warranty for a period not to exceed the remaining term of the original limited warranty or six (6) months, whichever is longer.

LIMITED 1 YEAR WARRANTY

The following parts of the Intrepid® II are warranted to be free of defects in material and workmanship for a period of one year from the date you receive it. These parts are the thermostat assembly, handles, glass door panels, cement, and gasketing. Any of these items found to be defective will be repaired or replaced at no charge, upon the return of said part to a Vermont Castings Authorized Dealer with postage prepaid.

Any part repaired or replaced during the limited warranty period will be warranted under the terms of the limited warranty for a period not to exceed the remaining term of the original limited warranty or six (6) months, whichever is longer.

LIMITED CATALYST WARRANTY

The catalyst will be warranted for a six year period as follows: If the original catalyst or a replacement catalyst proves defective or ceases to maintain 70% of its particulate emission reduction activity (as measured by an approved testing procedure) within 24 months from the date the Intrepid® II is received, the catalyst itself will be replaced free. From 25 - 72 months a pro-rated credit will be allowed against a replacement catalyst and the cost of labor necessary for replacement at the time of replacement. The customer must pay for any in-home travel fees, service charges, or transportation costs for returning the Intrepid® II to the Authorized Dealer.

AMOUNT OF TIME SINCE PURCHASE	CREDIT TOWARD REPLACEMENT COST
0 - 24 months	100%
25 - 36 months	50%
37 - 48 months	30%
49 - 60 months	20%
61 - 72 months	10%

Any replacement catalyst will be warranted under the terms of the catalyst warranty for the remaining term of the original warranty. The purchaser must provide the following information in order to receive a replacement catalyst under the terms of this limited warranty:

1. Name, address and telephone number.
2. Proof of original purchase date.
3. Date of failure of catalyst.
4. Any relevant information or circumstances regarding determination of failure.
5. In addition, the owner must return the failed catalyst.

EXCLUSIONS & LIMITATIONS

1. This warranty is transferable; however, proof of original retail purchase is required.
2. This warranty does not cover misuse of the Intrepid® II. Misuse includes overfiring which will result if the Intrepid® II is used in such a manner as to cause one or more of the plates to glow red. Overfiring can later be identified by warped plates and areas where the paint pigment has burned off. Overfiring in enamel stoves is identified by bubbling, cracking, chipping and discoloration of the porcelain enamel finish. Vermont Castings offers no warranty on chipping of enamel surfaces. Inspect your Intrepid® II prior to accepting it for any damage to the enamel.
3. This warranty does not cover misuse of the Intrepid® II as described in the Owner's Guide, nor does it cover an Intrepid® II which has been modified unless authorized by a Vermont Castings representative in writing. This warranty does not cover damage to the Intrepid® II caused by a salt environment or from burning salt saturated wood, chemically treated wood, or any fuel not recommended in the Owner's Guide.
4. This warranty does not cover an Intrepid® II repaired by someone other than a Vermont Castings Authorized Dealer.
5. Damage to the unit while in transit is not covered by this warranty but is subject to a claim against the common carrier. Contact the Vermont Castings Authorized Dealer from whom you purchased your Intrepid® II or Vermont Castings if the purchase was direct. (Do not operate the Intrepid® II as this may negate the ability to process the claim with the carrier.)
6. Claims are not valid where the installation does not conform to local building and fire codes or, in their absence, to the recommendations in our Owner's Guide.

HOW TO OBTAIN SERVICE

If a defect is noted within the warranty period, the customer should contact a Vermont Castings Authorized Dealer, or Vermont Castings if the purchase was direct, with the following information:

1. Name, address, and telephone number of the purchaser.
2. Date of purchase.
3. Serial number from the label on the back of the stove.
4. Nature of the defect or damage.
5. Any relevant information or circumstances, e.g., installation, mode of operation when defect was noted.

A warranty claim will then start in process. Vermont Castings reserves the right to withhold final approval of a warranty claim pending a visual inspection of the defect by authorized representatives.



The distinctive appearance of the front of the Intrepid®II is a registered trademark of Vermont Castings, Inc.® U.S. TM Reg. No. 1,195,615.
Mechanical Patents - U.S.: 4,487,195; 4,510,918; 4,582,044; 4,636,712
Design Patent - U.S.: D275,878
Other U.S. and foreign mechanical and design patents pending.

Vermont Castings, Inc.
Prince Street
Randolph, Vermont
U.S.A.

Vermont Castings, Inc.
44 Friargate
Derby
Derbyshire DE1 1DA
England

February ©1989 Vermont Castings, Inc. All rights reserved. Prices and specifications subject to change without notice.

Printed in the U.S.A.

#20917C