

*For Ed + Jan's old
Resolute*

Vermont Castings OPERATION MANUAL

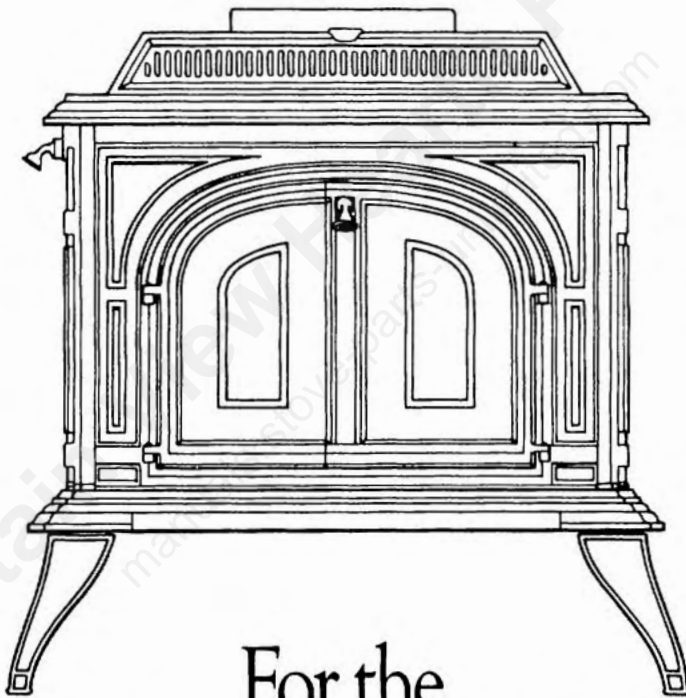

For the
Defiant® Vigilant® Resolute® & Intrepid®
Wood & Coal Parlor Stoves

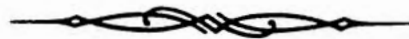

A Philosophy...A Commitment

We build wood stoves because we believe there are sensible ways to heat our homes without exhausting our precious oil supplies. Vermont Castings was founded on this philosophy and it continues to guide us today.

When we began making stoves, wood was our first choice as an alternative to heating with oil. The chemical reaction that occurs within the leaf is the only known natural exchange that can store the sun's energy. In every sense, wood heat is a loan from the sun. If we fail to use it to warm ourselves, wood heat will eventually be consumed by rot, and decay into the atmosphere. The loan is brief, not much longer than the span of a human life. We encourage you, through the ownership of our stoves, to take this loan and use it wisely for your benefit and pleasure. If we are careful in the harvesting of wood, our forests will supply us with a lasting supply of fuel.

While wood is our only renewable fuel source, coal is one of America's most abundant resources. For many persons, especially our urban friends, it is difficult to find a ready supply of wood. Recognizing this, we recently introduced a coal burning stove, and a coal conversion unit for existing wood stoves.

Known coal reserves can meet our heating needs for years to come. But, as stewards of the earth we must abide by an ethic that mandates we burn coal as sparingly and efficiently as possible. By doing so, we ensure that there will be ample supplies of coal to warm the homes of future generations.

As responsible users of one of the earth's natural resources, we cannot ignore pollution problems related to the burning of coal. We made our stoves to be as efficient as possible and designed them to burn premium grade anthracite, the least polluting of any of the coal types. We suggest you check the availability of this coal in your area before making a decision to burn with coal.

Buying a wood or coal stove, especially a highly sophisticated one like ours, is a commitment. As the owner of one of the finest stoves made, you have made a commitment toward a lifestyle founded on the notion that one technology does not replace another, but allows us to become reconnected to the natural systems which support us. In doing so you acquire a new vocabulary. This operation manual summarizes our knowledge. Combined with your effort, it will provide the information you need to reach your goals. We at Vermont Castings feel that your commitment to your new stove, in some cases a very new experience, will be amply awarded.

How To Use This Manual

This manual contains a great deal of information and is not easily digested in one sitting. Before you light your first fire, read it thoroughly, especially the Operations instructions. Otherwise, you may damage your stove. Read it again after the stove has been in service for a while. Many of the difficult to understand points will become clear. If you have further specific questions about the installation of your stove and the clearances necessary for safe operation, please contact our Customer Relations Department at 802/728-3111. We have an installation guide and other technical information available to help answer many questions. We will be happy to discuss your particular problems either by mail or over the telephone.



WELCOME

As a Vermont Castings' stove owner, you join a unique community of persons dedicated to using alternate energy sources. Whether or not this is your first experience with wood or coal, you are assured of our continued support and guidance to help you gain the maximum benefit and enjoyment from your new stove.

This special relationship is extended to you through our Customer Relations Department and the Owners' News. Many members of the Customer Relations Department heat their homes with our stoves. All of them have either installed or operated a stove. In addition to this "hands-on" experience, they are well versed in every aspect of heating with wood and coal. Periodically, you will receive copies of our Owners' News. Your first copy was packed in your stove. In it we provide helpful hints which will give you the benefit, not only of our experiences but those of other customers as well. Please take advantage of the Owners' News to share secrets you discover with other stove owners.

It has always been the philosophy of Vermont Castings to maintain direct contact with our customers. We hope to learn as much from you as you learn from us. If problems do occur, we can draw on the experience of thousands of stove owners to help you. Very few manufacturers have this advantage, an advantage which becomes yours when you purchase your Vermont Castings stove.

We have tried to make this manual as easy to read as possible. We urge you to familiarize yourself with it before setting up your stove. Familiarize yourself with the parts of the stove and their functions so that it will be easier to understand the information in the manual. The clear chapter headings should facilitate your task. Read the chapters in order. If you have already completed your plans and the work necessary for installation, you might like to move ahead to the chapter on setting up the stove. Once again we caution you to please read through the material at least once before you make the final installation connection and build your first fire.

INDEX

- 2 The Inside Story
- 6 Installation
- 10 Operation
- 13 Maintenance

SAFETY NOTICE:

IF YOUR DEFIANT, VIGILANT, RESOLUTE OR INTREPID IS NOT PROPERLY INSTALLED, A HOUSE FIRE MAY RESULT. FOR YOUR SAFETY, FOLLOW THE INSTALLATION DIRECTIONS. CONTACT LOCAL BUILDING OR FIRE OFFICIALS ABOUT RESTRICTIONS AND INSTALLATION INSPECTION REQUIREMENTS IN YOUR AREA.

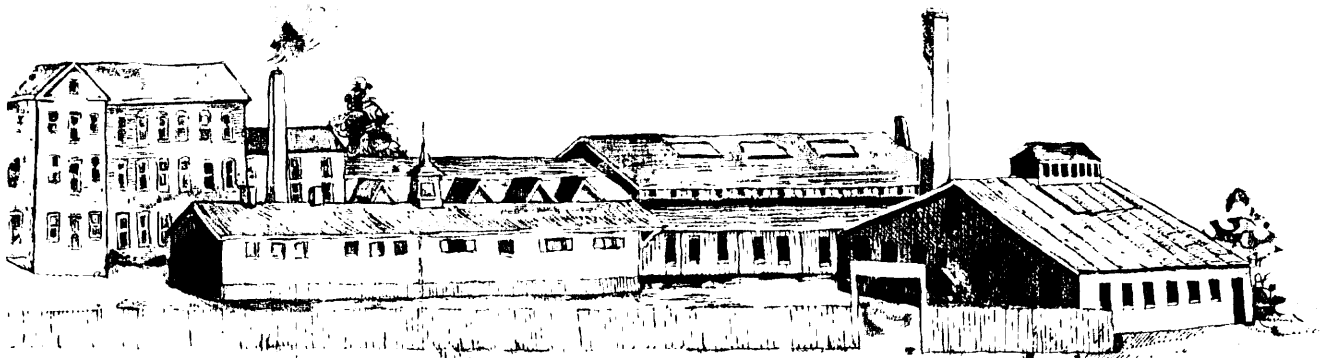

THE INSIDE STORY

Economics & Efficient Combustion The How & Why

It has been our experience that if you understand the inner workings of your stove you will be better equipped to use your stove wisely and to gain maximum savings and pleasure from its daily use. That is why this section on the efficiency and combustion principles of the stoves is included before you reach the installation information. Where the principles for wood and coal-burning differ, the fuel and its particularities are identified. Although all three stoves are different in features, sizes and heat outputs, their combustion systems are similar.

Let us start your tour of the inner workings of the stoves with a discussion of *horizontal combustion*, the fundamental concept behind the operation of our wood stoves. In horizontal combustion, the flames move horizontally as they leave the primary combustion zone. Many stoves employ *updraft combustion*, in which flames rise up through the fuel load. All wood loaded into an updraft stove becomes part of the fire mass unless oxygen is restricted to a very low level. Our horizontal flamepath allows only the bottom of the wood load to burn. The logs on top are dried by heat and fall into the flame area as those below are consumed. Thus, a full wood load can provide heat all night long.

The use of horizontal combustion allows us to place the fuel in a *magazine* where the fueling of the fire is automatically accomplished by gravity. All of our stoves, both wood and coal, are magazine burners providing maximum efficiency with minimum tending.

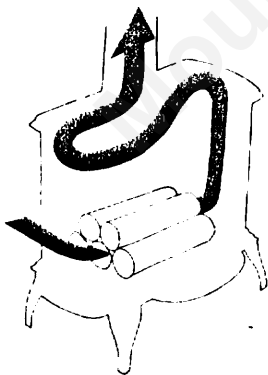

Horizontal combustion

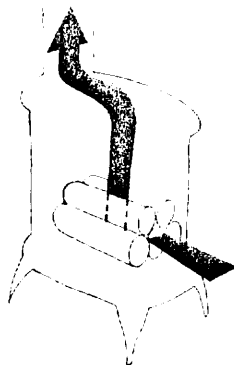

Updraft combustion

Fuel Limiting:

There are two ways to control the volume of power output in a combustion device: fuel limiting and oxygen limiting. An automobile is fuel-limited. If you need more power, you supply the engine with more fuel. If you make an uncontrolled amount of gasoline available to the spark plugs at once, the engine becomes an inefficient source of power.

An updraft stove, which is the system most commonly employed in the United States, is much like a runaway automobile in that it places the entire fuel supply in the combustion zone at once. In order to prevent a runaway updraft stove, the fire is partially smothered, creating thick smoke and low efficiency. Our magazine system uses no more than the amount of fuel necessary in the combustion zone at any one time in order to produce the maximum amount of heat for which the stove was designed. In order to slow the fire below these points, we use oxygen limiting with an *automatic thermostat* which provides the fire with an appropriate level of oxygen.

Air Control Systems

Primary Air Systems

In both our wood and coal stoves, oxygen enters at the thermostatically controlled *Inlet Air Shutter* and travels through passages where it is heated before being fed to the fire mass through the *Primary Air Ports*.

When a fuel is heated and burns, the volatile combustible gases naturally locked in it are driven off. In an updraft combustion stove or fireplace, these volatiles are usually left unburned for two reasons. First, by the time the gases have left the fuel, they are too cool to ignite. Second, the oxygen that enters the stove is usually consumed by the glowing coals at the base of the fire mass, so the gases rise through an atmosphere too deficient in oxygen to allow combustion to take place. The loss of volatile gases is serious in the case of wood, for it represents approximately half the total heat value.

Secondary Air Systems

Our stoves facilitate the burning of these volatiles in several ways. By using horizontal combustion, the gases are forced to pass close to hot coals which maintain a sufficiently high temperature (as high as 1200° Fahrenheit) for ignition.

Our stoves also employ a sophisticated system which introduces another source of preheated air (secondary air) to encourage combustion of these volatile gases. The *secondary combustion* of gases that, because of an insufficient oxygen supply, were unable to ignite within the primary combustion zone, are encouraged to release their heat. Secondary air treatment of the coal stoves is different because of the individual characteristics of coal and wood.

The inner workings of the Defiant

Heat-regulating thermostat.
Automatically controls air intake to assure steady, even heat all day, all night long.

Secondary combustion chamber.
Allows unburned gases to combine with oxygen, providing additional heat.

The baffle.
Creates a longer flamepath for maximum heat transfer.

Secondary air tube.
Feeds preheated oxygen to secondary combustion chamber.

Smoke shelf.
Directs spent gases into upper chamber, where they release additional heat before rising up flue.

Primary air entry ports.
Disperse preheated air evenly into combustion zone.

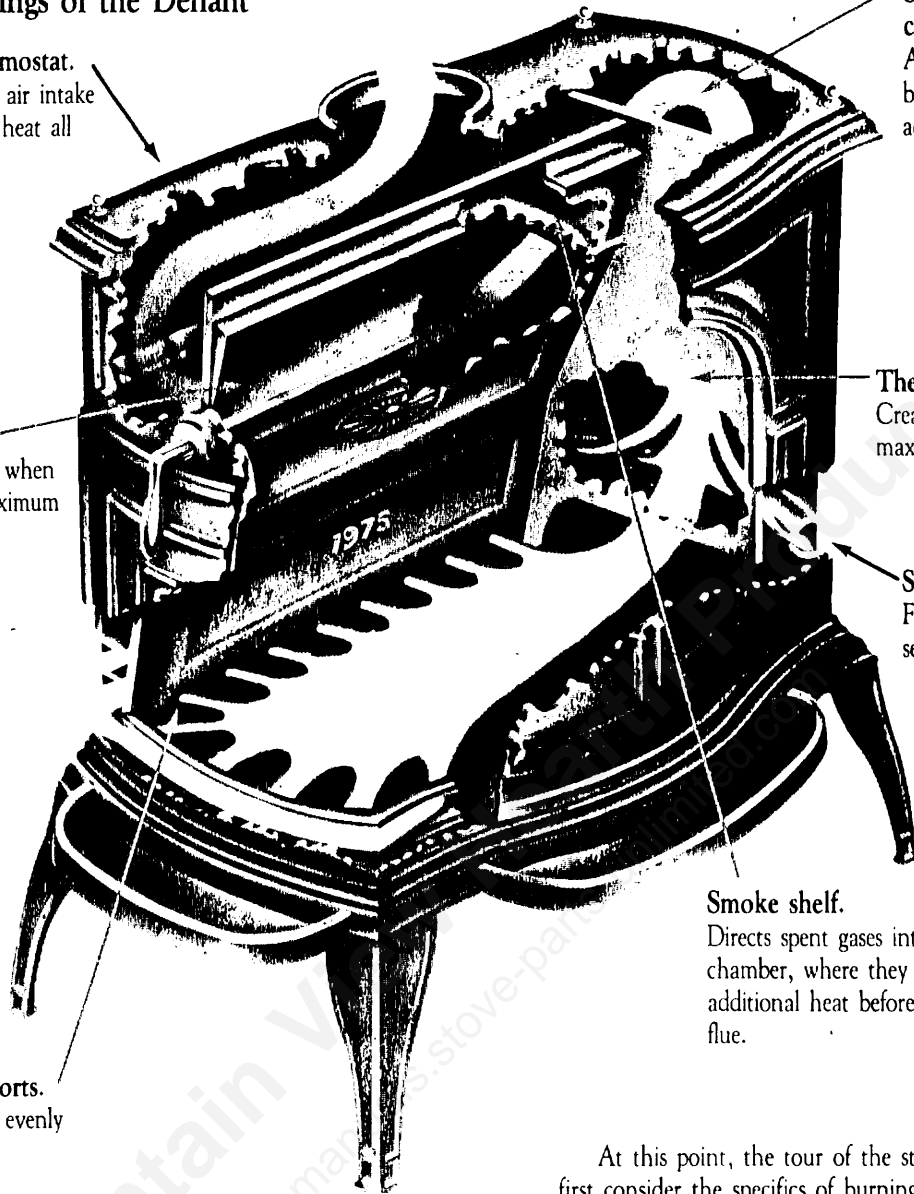

Thermostat Control

The thermostat lever at the back of the stove controls the Inlet Air Shutter, and thus the amount of air entering the stove for combustion. Attached to this lever is a bimetallic coil which contracts or expands to the heat given off from the stove. A ball chain connects the lever to the air inlet shutter, thus regulating the flow of incoming combustion air. As a result the stove's heat output intensifies and the air supply is decreased. The combustion rate slows, heat output drops, and the air supply is again allowed to increase as the bimetallic coil reopens the air intake shutter.

The thermostat lever can be set to accommodate your individual heating requirements. The overall heat output throughout the burn period is determined by the lever setting. The length of burn is similarly related to the lever setting as a high heat output will necessarily allow faster fuel consumption than will a lower heat output setting. The most efficient use of the stove and fuel can be made by setting the thermostat to allow a moderately hot fire. Long, smoldering burn periods should be avoided.

At this point, the tour of the stoves must diverge. We will first consider the specifics of burning wood, and then move on to discuss the specifics of coal-burning.

THERMOSTAT OPERATION

- View of thermostat for Defiant and Vigilant is with thermostat cover removed
- Resolute bimetallic coil is reversed

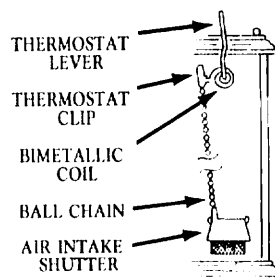

a. After fire is well established, set thermostat to desired heat output.

AIR INTAKE SHUTTER
HALF OPEN

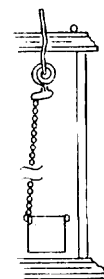

b. As heat output intensifies air intake is decreased.

AIR INTAKE SHUTTER
CLOSED

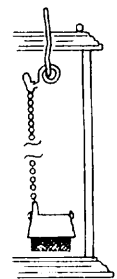

c. As heat output lowers, air intake increases.

AIR INTAKE SHUTTER
HALF OPEN

INSTALLATION

SAFETY NOTICE:

IF YOUR DEFIANT, VIGILANT, RESOLUTE OR INTREPID IS NOT PROPERLY INSTALLED, A HOUSE FIRE MAY RESULT. FOR YOUR SAFETY, FOLLOW THE INSTALLATION DIRECTIONS. CONTACT LOCAL BUILDING OR FIRE OFFICIALS ABOUT RESTRICTIONS AND INSTALLATION INSPECTION REQUIREMENTS IN YOUR AREA.

A separate bulletin, "The Vermont Castings' Installation Planning Guide," contains detailed information to help you plan your installation. Read this manual and the Installation Planning Guide before installing your stove. For further information on using your stove safely, obtain a copy of the National Fire Protection Association publication "Using Coal and Wood Stoves Safely," NFPA No. HS-10-1978. The address of the NFPA is Batterymarch Park, Quincy, Massachusetts 02269.

Please note: Vermont Castings stoves are not approved or recommended for use in mobile homes.

Set Up

Our stoves are heavy and require at least two people to move and set them up. To make the job a bit easier, you may lift off the loading doors and remove the griddle. (The Defiant griddle is held in place with two latches.) DO NOT TRY TO MOVE THE STOVE ALONE AS THE STOVE CAN BE DAMAGED BY MISHANDLING.

Place the stove close to its final position before installing the stove legs. You will find stove leg assembly instructions in the leg bolt package.

So that you can easily secure the first section of stove pipe to the stove, three holes have been drilled in the flue collar and three sheet metal screws are included in the leg bolt package.

The griddle has not been painted in order to allow cooking directly on its surface. In order to protect the surface from rust during shipping, a coating of grease has been applied. Be sure to wash the griddle thoroughly with soap and water. As the stove is used, the griddle will gradually darken to match the color of the stove.

If you have ordered any accessories such as andirons or heat shields, they will come with their own installation instructions. Generally speaking, nothing more complicated than a screwdriver is involved in the installation of accessories.

Placement

Stove placement is crucial for even heat distribution in your home. Since a radiant stove depends upon efficient air circulation to disperse its heat, a central location in the house or in the living area is best. However, your installation may be influenced by the position of an existing chimney flue, by required clearances to combustible walls or by aesthetic considerations.

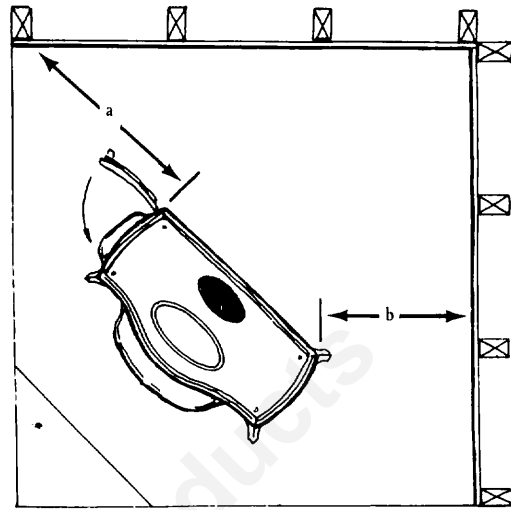

FIG.1
CORNER INSTALLATION
NO SHIELDING
COMBUSTIBLE WALL

- a) Load door end requires min. 36" to wall
- b) Min. 36" clearance to wall from rear and side

We are prepared to help you with questions concerning placement of your stove. Floor plan sketches either by you or your architect will help us evaluate your individual situation. If you like, please ask your architect or building contractor to contact us directly.

Clearances

It is important for proper installation that the stove is located with adequate clearance to combustible walls and room furnishings. The recommended minimum clearance for all stoves from combustible walls is 36". Combustible room furnishings should be kept a considerable distance away from the stove.

Clearance between the stove and walls can be reduced with use of wall protection or with the installation of Vermont Castings stove and stovepipe heat shields. Clearance reductions, however, vary greatly depending on the stove model and the type of installation. Consult the *Vermont Castings Installation Planning Guide* for specific clearance dimensions and wall protection requirements.

Chimneys

Many homes are already equipped with a sound freestanding masonry chimney or a fireplace chimney. Either of these can provide an excellent flue through which to vent a wood or coal stove, provided they are built according to local building codes. We recommend that prior to installing a stove into an existing flue, you have the chimney inspected by a qualified professional. Your local building inspector will know who is qualified to assess the condition of your chimney. If your masonry chimney is not constructed with a clay tile liner, we cannot recommend that you use it in its existing state with any wood or coal burning device. An unlined chimney may have unseen loose mortar which could allow chimney gases to escape into the house, or, a chimney fire could ignite nearby wooden members.

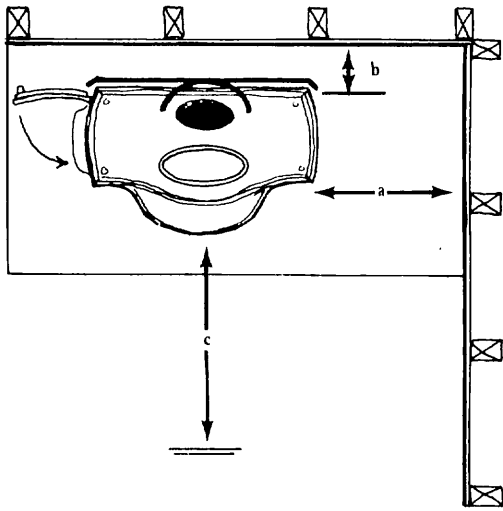

FIG. 2
SIDE INSTALLATION
REAR PIPE AND STOVE SHIELDS
COMBUSTIBLE WALL

- a) Min. 36" clearance to wall from side
- b) Min. 10" clearance to wall with use of stove and pipe heat shields
- c) Min. 36" clearance from loading door to any combustible room furnishings

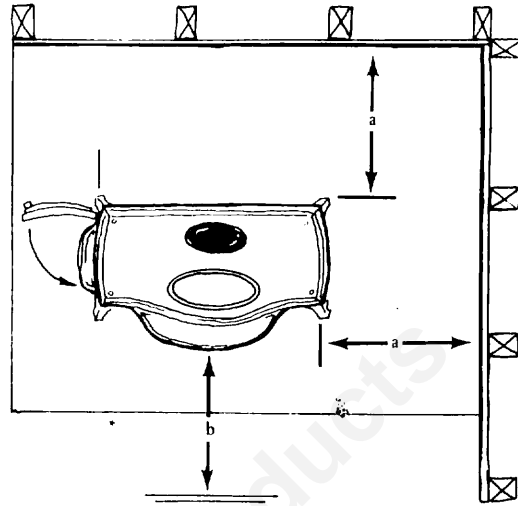

FIG. 3
TOP EXIT DEFIANT
SIDE INSTALLATION
NO PROTECTION
COMBUSTIBLE WALL

- a) Min. 36" clearance to wall from side and rear
- b) Min. 36" clearance from load or front doors to any combustible materials, i.e., furniture

If you are building a chimney from scratch, we cannot stress strongly enough the importance of an interior chimney. When properly built, it is the best chimney of all, and will more than repay you for the space that it requires. Besides minimizing condensation of creosote, the draft produced in an interior masonry chimney will be stronger, helping the stove burn more efficiently. In new masonry construction, allow for the use of a minimum of eight by eight inch clay flue tile. The chimney must be constructed in accordance with your local building code.

You may prefer to install a factory built metal chimney. Prefabricated chimney systems require no foundation and are relatively quick and easy to install. Other advantages of prefabricated chimneys are that they generally require less space and are less

expensive than their masonry counterpart. Make sure that such a chimney is approved for solid fuel and is listed by a nationally recognized testing laboratory such as the Underwriters Laboratory (UL). It must be installed in accordance with the manufacturer's instructions. CLASS B type chimneys may not be used with wood or coal stoves. These flues are designed to vent gas appliances only. There are several prefabricated chimney designs available; we recommend those which will help maintain high flue gas temperatures, such as the double wall or static air insulated type. Ask your local dealer about specific manufacturers.

Do not connect the stove to a chimney flue serving another appliance.

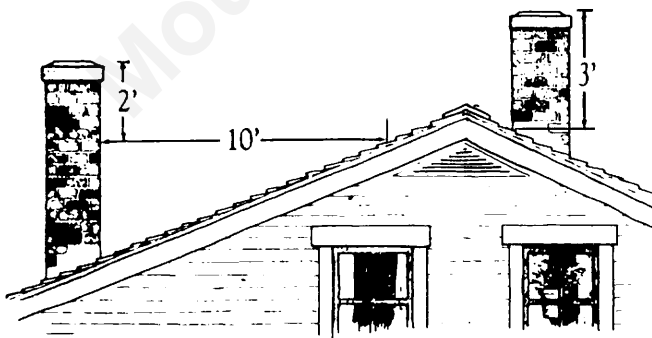

FLUE HEIGHT REQUIREMENTS

The chimney must extend 3 feet above the level of roof penetration and a minimum of 2 feet higher than any roof surface within 10 feet. Check your local codes for additional regional guidelines. While a minimum chimney height of 16 feet is generally recommended, factors affecting stove performance such as local terrain, prevailing winds, and adjacent structures may necessitate use of a taller flue.

IDEAL FLUE SIZES

Vermont Castings stoves are designed to perform most efficiently when vented through flues having the following dimensions:

	Liner Size	Round Liner Diameter
Defiant/Vigilant	8" x 8" or 8" x 12"	8" interior diameter
Resolute/Intrepid	8" x 8" or 8" x 12"	6" x 8" interior dia.

Larger flues (12" x 12", 12" x 20"), although generally effective, can lessen chimney draft and promote cool flue gas temperatures. Vermont Castings stoves are not listed for installation into flues smaller than the sizes recommended above.

If you are planning to vent a small stove into a large flue, particularly an exterior masonry one, you may find it necessary to insulate the chimney, reline the chimney, or operate the stove to maintain high flue temperatures.

Stovepipe/Chimney Connector

We recommend that stoves be placed close to their chimneys so that the stovepipe can be as direct and short as possible, with a minimum of elbows and angles. Exhaust gases from the stove will flow unrestricted into the chimney flue. Long horizontal runs of stovepipe should be avoided since they tend to build up ash and soot more quickly and, therefore, require more frequent cleaning.

The size of a stovepipe and chimney thimble should never be smaller than the flue collar area of the stove. A minimum 8 inch diameter stovepipe and chimney thimble are required for the Defiant and Vigilant, and 6 inch minimum diameter for the Resolute.

The stovepipe must be constructed of 24 gauge or thicker sheetmetal. All stovepipe sections should be fastened together with three sheetmetal screws, spaced equidistant around the perimeter of the pipe to prevent separation during use. In addition, the first section of stovepipe should be fastened to the flue collar of the stove.

Stovepipe systems should be designed if possible with the crimped end of the stovepipes pointing downward so that any soot or creosote which is formed will run down back into the stove and be consumed.

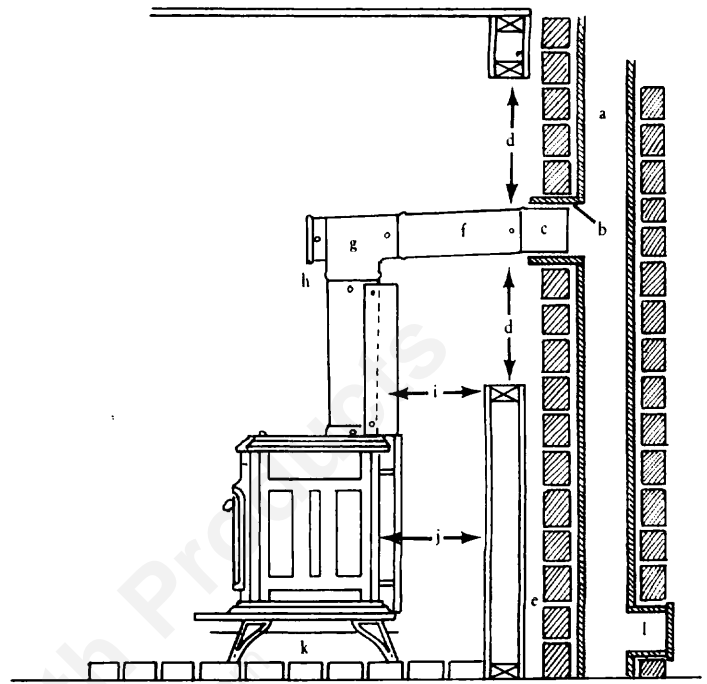

TOP-EXIT STOVE INSTALLED IN THIMBLE THROUGH COMBUSTIBLE WALL

- a) Tile liner
- b) Thimble
- c) Stovepipe must not extend into chimney liner
- d) Proper clearance between pipe and unprotected combustible materials. (see below).
- e) 2" min. between chimney and combustible materials
- f) 1/4" rise per foot of horizontal run
- g) Clean-out tee
- h) All pipe joints secured with 3 sheet metal screws
- i) Stovepipe heat shield allows 10" clearance to combustible materials
- j) Stove heat shield allows 10" clearance to combustible materials
- k) Bottom heat shield
- l) Clean-out access with tight door

Stovepipe must be installed to maintain the following minimum clearances to unprotected combustible materials.

- Defiant Installation - 22"
- Vigilant Installation - 22"
- Resolute Installation - 23"
- Intrepid Installation - 25"

Stovepipe heat shields and/or wall protection can be used to reduce these clearances. See the *Vermont Castings Installation Planning Guide* for detailed information concerning your specific installation requirements.

All chimney connections should be carefully made in accordance with all local building codes and manufacturers' recommendations.

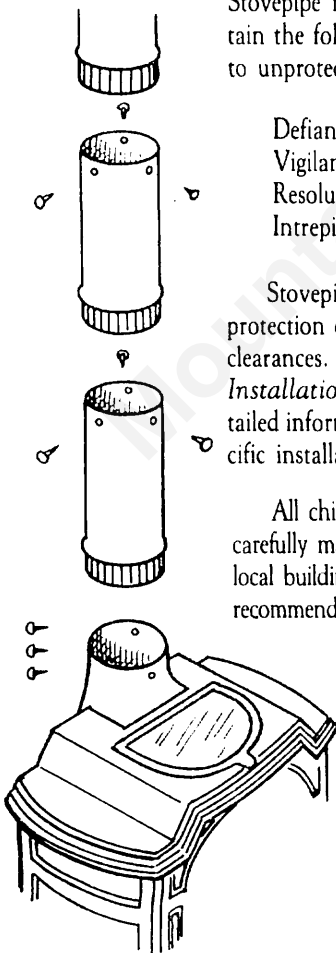

Stovepipe Dampers

Because of the draft requirements of our stoves, we do not recommend the use of an in-flue damper. Not only is this an unnecessary restriction in the flue, but it is an additional surface directly in the path of flue gases upon which deposits can form, creating a potential hazard. Combustion air entering Vermont Castings stoves is controlled effectively by the thermostat, so no flue damper is required.

Floor Protection

Even though temperatures under our stoves are significantly lower than those to the sides of the stoves, no stove should ever be installed on a combustible surface because of the possibility of falling embers. Our stoves have generous ashtraps, but some coals may escape from time to time. For this reason, and to provide heat protection to your floor, we recommend you install a hearth consisting of two sheets of 1/4-inch asbestos cementboard or mill-board covered by one sheet of 24 gauge galvanized sheet metal.

If you prefer a more decorative hearth cover than the above recommendations, the installation of an optional Vermont Castings' bottom heat shield will allow use of a variety of materials. Details concerning those options are printed in *Vermont Castings' Installation Planning Guide*.

We recommend that your hearth or stove pad extend a minimum of twelve inches beyond the back and sides of the stove