

Rear Heat Shield - Installation Instructions for the Defiant, Vigilant, Vigilant II, Resolute, Intrepid and Intrepid II

VERMONT CASTINGS

Read these instructions and save them for future reference.

NOTE: Where this instruction sheet refers to the “Defiant” stove, it is referring to units built from 1975 to 1988. These units do not have glass panels in the doors. The heat shield supplied with this kit will not fit the 1998 (Model #1910) Defiant, which has glass in the doors.

The rear heat shield has been designed to reduce wall temperatures directly behind the stove. It is essential that you install the shield properly, and follow recommended wall clearances as specified in the Owner’s Guide for your stove. Distances should be measured from the stove top to the wall, unless specified otherwise in the manuals for your stove.

It is equally important to follow recommended clearances from the stovepipe chimney connector to nearby combustible material (walls, the ceiling, and in fireplace installations, to the mantel and trim pieces). These distances are also given in the Owner’s Guide for your stove. Stovepipe or fireplace mantel shields may be needed to reduce temperatures of surfaces near the stovepipe chimney connector.

Important Safety Note

For the Defiant, Resolute, Intrepid, Intrepid II and Vigilant II Coal Stove: the flue collar insert must be used when the stove is in the top-exiting position and a rear heat shield is required.

The Vigilant II Coal Stove has the ash pan located in the ash drop below the bottom of the stove. The flue collar insert is not required on other Vigilant wood or coal stoves.



Do not paint the inside of any heat shield as this would reduce the ability of the shield to reflect heat. Clean the inside of all heat shields yearly.

Record the serial number from the metal plate on the back of your stove before installing the rear heat shield.

Except for small differences, installation procedures for all five stoves listed in these instructions are similar. For all stoves, the name of the stove is cast in the side plate. Be sure to use the correct instructions for your stove. The only tool needed to install the shield is a screwdriver.

Materials Provided:

The correct Rear Heat Shield for your stove

- (4) - 2” Nickel-plated Spacers (Vigilant, Resolute, Intrepid)
- (4) - 2-1/2” Nickel-plated Spacers (Defiant)
- (4) - 1-1/4” Nickel-plated Spacers (Intrepid II)

NOTE: The shape of the rear heat shield and the flue collar insert varies for the different stoves. All shields are installed in the same way, and serve the same purposes.

Installation Instructions

1. Remove the truss head screws from the threaded heat shield holes on the back of the stove.

On Defiants produced before July of 1980 and all Vigilants, this means removing the nickel-plated thermostat cover. The nickel-plated cover is not used when a rear heat shield is installed. Save the cover. If you change your stove location and the rear heat shield is not installed, the nickel-plated thermostat cover should be used.

On Defiants produced after July of 1980 and on Resolutes and both Intrepids, the threaded heat shield hole is beside the cast iron thermostat cover. The cast iron cover is left in place when the rear heat shield is installed. Save the screws as they will be used later to attach the heat shield.

- 2a. **For the Intrepid II ONLY:** The rear heat shield is packaged with the flue collar insert in place on the shield. If your Intrepid II will be installed with the flue collar in the top-exiting position, leave the insert in place. (Figure 2) If your stove will be installed with the flue collar in the rear-exiting position, remove the insert. (Figure 2) To remove the insert, remove the two sheet metal screws holding it to the rear heat shield. Tape the screws to the insert. Save the insert and screws for use if the stove installation is changed and the flue collar is in the top-exiting position.

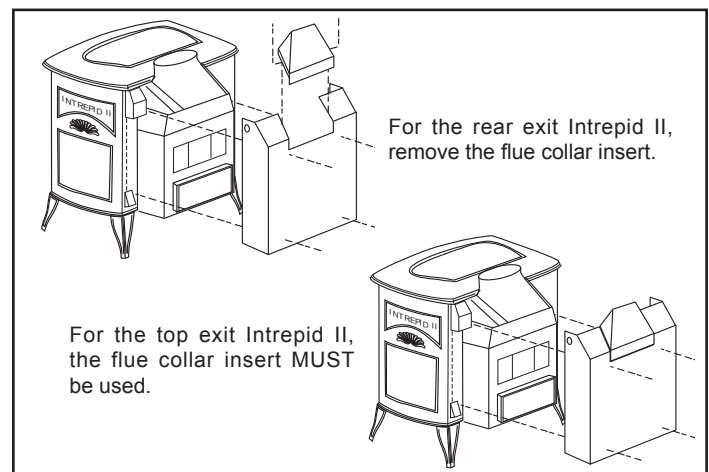

Figure 2 - Intrepid II flue collar insert.

2b. For the Vigilant II Coal Stove described in the SAFETY NOTE ONLY: (ash pan located in the ash drop below the bottom of the stove). The flue collar insert is shipped flat and must be folded to the correct shape before installation. When folded correctly, the insert will be attached to the outside of the heat shield as illustrated. (Figure 3)

The unpainted, shiny side of any heat shield must face the hot surface of the stove, flue collar or chimney connector. As you fold the metal, be sure the unpainted sides face in toward each other. Because the metal is perforated where it must be bent, shaping the insert will be easy. Adjustments can be made for a good fit. However, avoid re-bending too many times as this could weaken the metal.

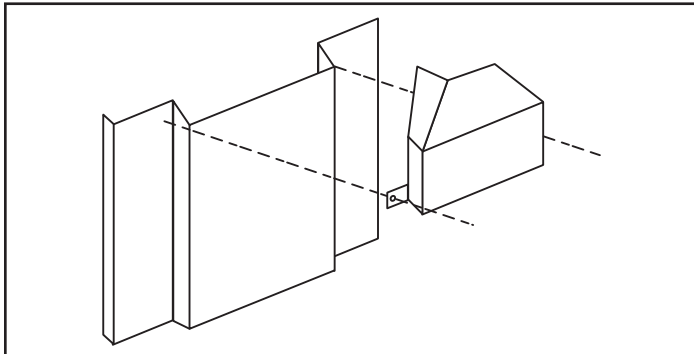

Figure 3 - Vigilant II flue collar insert.

To fold the insert (Figure 4):

- Fold the two ends straight up so they make a right angle (90°) with the bottom section of the back of the insert. Fold the two ears out at right angles with the ends.
- Bend the top section back slightly.
- Fold the wings straight up so they make a right angle with the upper section of the back. Exception: For Vigilants with 8" flue collars, the wings should flare out slightly.

The holes in the ears of the insert will match the top holes in the heat shield.

NOTE: Your Vigilant Flue Collar Insert may have a hole at the center of the bottom edge. This hole is used during manufacture of the insert only, and is not used during installation of the insert.

3. Select the correct length heat shield spacers for your stove. Thread the spacers into the threaded holes on the back of the stove. For the Intrepid II, unscrew the ceramic handle from the damper handle stub.

Set the heat shield against the spacers, lining up the holes in the shield with the spacers.

For Vigilants that require the flue collar insert, place the insert on the outside of the heat shield with the holes of the insert lining up with the holes of the heat shield.

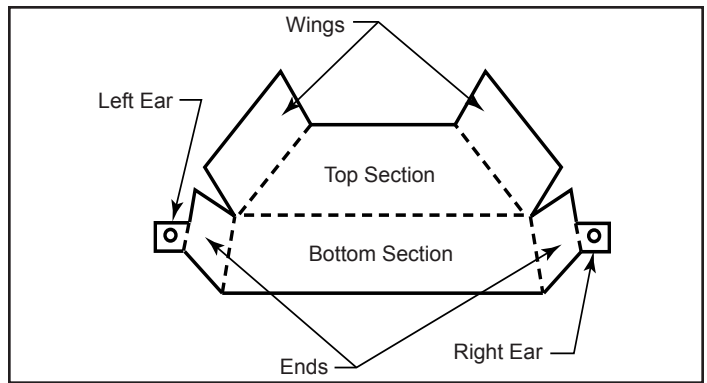

Figure 4 - Vigilant flue collar insert bends.

4. Fasten the heat shield (and insert if required per Step 2b) to the spacers using the truss head screws previously removed from the back of the stove. (Figure 5)

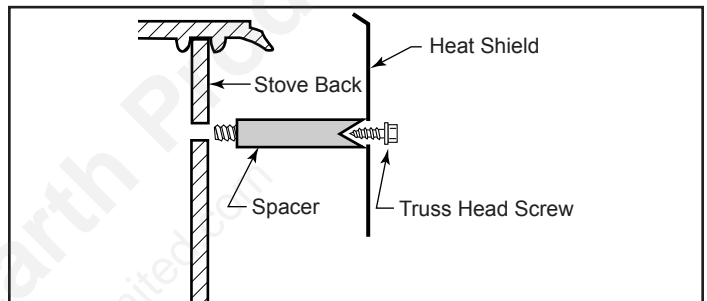

Figure 5 - Attach heat shield using spacers and truss head screws.

5. For the Defiant, Resolute and Intrepid, if the stove is in the top-exiting position, slide the flue collar insert into place. (Figure 6)

For the Intrepid II, if the stove is in the top-exiting position, the insert should already be in place. If it is not, attach the insert now as shown in Step 2.

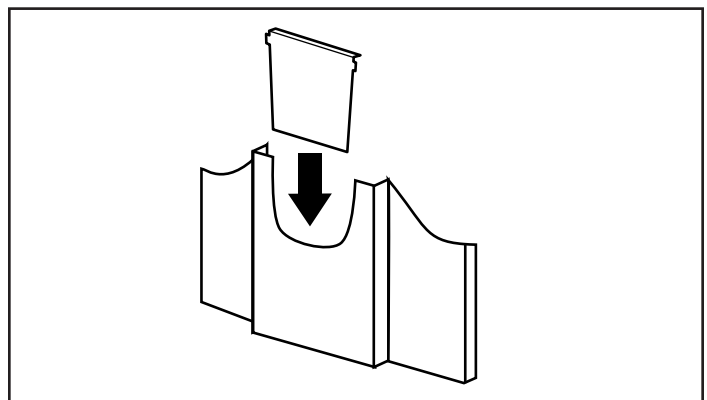

Figure 6 - Defiant, Resolute and Intrepid top exit position.

6. For the Intrepid II, screw the ceramic handle back on the damper handle stub.