

THE

WINTER WARM™

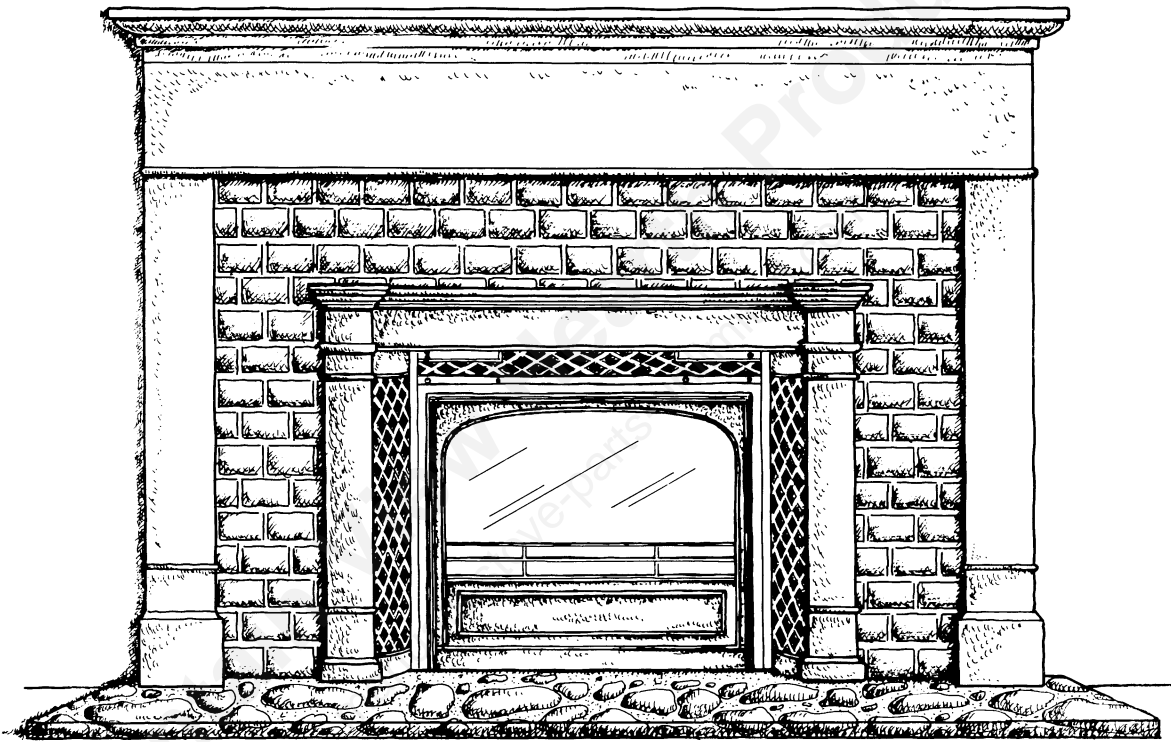

by **Vermont Castings**



— Large WinterWarm 1280 Insert Pre 01/91

— **OWNER'S GUIDE**

For Use in the U.S.A.
and CANADA

Cet guide d'utilisation est disponible en français chez votre concessionnaire de Vermont Castings.

Welcome

THE FIRE ON THE HEARTH

With the introduction of the WinterWarm™, Vermont Castings is proud to present an innovative dual-purpose combustion system which enables every homeowner to enjoy the warmth of a classic fireplace hearth while maintaining the efficiency of a modern air-limited heater. This fresh, new design allows the WinterWarm to be used in two completely different applications — as a standard fireplace insert in a traditional masonry fireplace, or as the "combustion engine" in a space-saving prefabricated fireplace system. With the same meticulous attention to detail that characterizes all Vermont Castings products, the WinterWarm combines today's progressive technology with the highest quality workmanship to produce an attractive, environmentally sound alternative to the old-fashioned inefficient fireplace.

Index

SPECIFICATIONS.....	3	MAINTENANCE	12
THE INSIDE STORY.....	4	Basics	
The Combustion Process		Glass Door Panel	
The Catalytic System		Column Blower Access	
The Stages of Combustion		Catalytic Element	
OPERATION.....	7	Gaskets	
Chimneys and Draft		Damper Adjustment	
The Controls		Chimney System	
The Break-In Fires		Firechamber	
Daily Operation		SAFETY TIPS	19
Ash Handling		GLOSSARY.....	20
		APPENDIX	21
		WARRANTY.....	22



How to Use This Manual

We have tried to make this manual as easy to read as possible. Because the WinterWarm is a dual-purpose combustion system, not all sections will apply to every installation. The manual is arranged so that the information which applies to every WinterWarm installation is presented first. Following the general information are specific details pertaining to masonry fireplace insert installations only or complete prefabricated fireplace system installations only. These specific details are highlighted so that you can easily find the information you need.

Most of the information in this manual pertains to both U.S. and Canadian installations. In the rare instances in which there are variations, flag symbols are used to denote the differences.

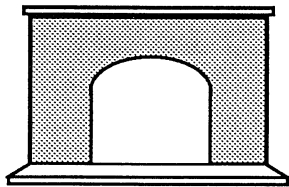

This symbol is used to highlight information specific to a WinterWarm installation in a masonry fireplace.

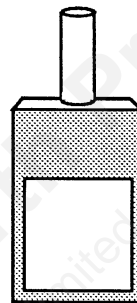

This symbol is used to highlight information specific to a WinterWarm installation using the insulated cabinet and an approved prefabricated chimney system.

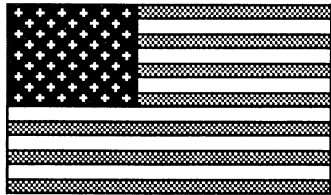

This symbol is used to highlight specific sections of the manual which apply only in the U.S.A.



This symbol is used to highlight specific sections of the manual which apply only in Canada.

Please read the entire manual at least once. This manual contains a great deal of information and is not easily digested in one sitting. Take your time, especially reading the Operation section.

Save These Instructions. Keeping the manual handy will allow you to refine your operating techniques as you develop skills and confidence. Read it again after you have used your WinterWarm for a while. Points which may be difficult to understand on first reading will become clear as you acquire hands-on experience. If you have questions, contact your local Vermont Castings Authorized Dealer. To obtain additional assistance, you may call 1-800-22-STOVE (1-800-227-8683) and speak directly to one of Vermont Castings Team Fireside Advisors. From Canada, call collect to 1-802-728-3181. Every Vermont Castings Authorized Dealer, and every Team Fireside Advisor, is committed to your satisfaction with your new WinterWarm Fireplace.

Specification Charts

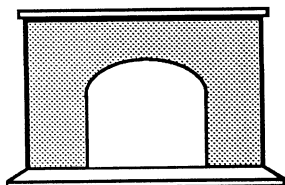

Range of Heat Output*	10,300 - 30,000 BTU/hr.	Primary Air Control	Manually set, thermostatically maintained
Maximum Heat Output**	50,000 BTU/hr.	Secondary Air Control	Self-regulating
Area Heated***	up to 1500 sq. ft. (140 sq. m.)	Glass Panel	High-temperature ceramic, 5 mm. thick
Fuel Capacity	40 lbs. (18 kgs.)	Flue Exit Position	Top, shallow or deep lintel
Size & Type of Fuel	20"-24" (500 mm.-600 mm.) wood splits	Blower rating (each)	130 cfm. (115 V, 60 Hz)
Loading	Front	Clearance to combustible surfaces (See Installation Manual for details)	Mantel/Top Trim 9"/250 mm. Side Trim 6"/150 mm. Furnishings 48"/1200 mm.
Flue Size	8" (50 sq. in.) minimum OR 200 mm. (320 sq. cm.) min.		
Weight	475 lbs. (216 kg.)		

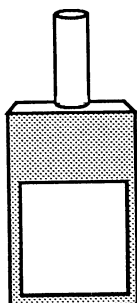

Range of Heat Output*	10,300 - 30,000 BTU/hr.	Primary Air Control	Manually set, thermostatically maintained
Maximum Heat Output**	50,000 BTU/hr.	Secondary Air Control	Self-regulating
Area Heated***	up to 1500 sq. ft. (140 sq. m.)	Glass Panel	High-temperature ceramic, 5 mm. thick
Fuel Capacity	40 lbs. (18 kgs.)	Flue Exit Position	Top, rear position
Size & Type of Fuel	20"-24" (500 mm.-600 mm.) wood splits	Blower rating (each)	130 cfm. (115 V, 60 Hz)
Loading	Front	Chase dimensions (See Installation Manual for details)	Height: 96"/2440 mm. Depth: 28.5"/730 mm. Width: 39.5"/1010 mm.
Flue Size	8" (50 sq. in.) minimum OR 200 mm. (320 sq. cm.) min.		
Weight	840 lbs. (380 kgs.)		

* Under specific test conditions used during EPA emissions standard testing.

** This value can vary depending on how the unit is operated, and the type and moisture content of the fuel used. Figure shown is based on maximum fuel consumption obtained under laboratory conditions, and on average efficiencies.

*** These values are based on operation in building-code conforming homes under typical winter climate conditions in New England. If your home is of non-standard construction (e.g., unusually well-insulated, not insulated, built underground, etc.) or if you live in a more severe or more temperate climate, these figures may not apply. Since so many variables affect performance, consult your Vermont Castings Authorized Dealer to determine realistic expectations for your home.

INSTALLATION INSTRUCTIONS

Installation instructions are presented in two separate manuals. For installation into a masonry fireplace, use the WinterWarm Fireplace Insert manual. For installation into the insulated cabinet with an approved prefabricated chimney, use the WinterWarm Fireplace System manual. Both manuals come with your WinterWarm firechamber. Fireplace System instructions are also packed with the WinterWarm Fireplace System cabinet. Be sure to use the instructions which are written specifically for your installation.

SAFETY NOTICE: IF YOUR WINTERWARM FIREPLACE INSERT OR FIREPLACE SYSTEM IS NOT PROPERLY INSTALLED, OPERATED AND MAINTAINED, A HOUSE FIRE MAY RESULT. FOR SAFETY, FOLLOW ALL INSTALLATION, OPERATION AND MAINTENANCE DIRECTIONS. CONTACT LOCAL BUILDING OFFICIALS ABOUT RESTRICTIONS AND INSTALLATION INSPECTION REQUIREMENTS IN YOUR AREA.

The WinterWarm™ Fireplace Insert and the WinterWarm™ Fireplace System were tested by Underwriters' Laboratories of Canada, and are listed by Underwriters' Laboratories and Underwriters' Laboratories of Canada. The WinterWarm™ is listed for burning wood. Do not burn other fuels.

The Vermont Castings WinterWarm™ Fireplace Insert and the WinterWarm™ Fireplace System are in compliance with the standards set forth by the Federal Environmental Protection Agency, 40 CFR Part 60.532(b), as stated on the permanent label attached to each appliance.

THE INSIDE STORY

Your WinterWarm is actually a highly sophisticated combustion system, designed to deliver maximum energy efficiency while maintaining the aesthetics of fireviewing. It has been our experience that if you understand the inner workings of your WinterWarm you will be better able to use it wisely and gain maximum savings and pleasure from your investment. This knowledge is as important for installation as for daily use, since good performance depends on both correct installation and proper operation. Read this section as well as the appropriate Installation Manual before you install the WinterWarm in your home.

The Combustion Process

The combustion of wood is a complex process. The following discussion breaks the process down into stages, but remember, all steps may occur simultaneously.

STAGE 1. EVAPORATION OF INHERENT MOISTURE

Moisture is evaporated from near the surface of burning wood. Energy is consumed during this drying process, and must be supplied from other burning wood or kindling. The amount of moisture in the wood affects the rate at which it burns. The higher the moisture content of the wood, the more energy required to dry it and the slower the rate of initial combustion.

STAGE 2. RELEASE OF VOLATILE MATERIALS

A large percentage of wood's energy, one-third or more, is contained in the gaseous and liquid/vapor materials released as the wood's temperature reaches the 500° F. to 600° F. range (260 C to 315 C). These gases and vaporized tars (commonly referred to as smoke) are by-products of the distillation (pyrolysis) of lignum and cellulose. They contain molecules composed of various combinations of carbon, hydrogen and oxygen.

STAGE 3. CHARCOAL COMBUSTION

When the volatiles have been driven from the wood, the remaining material is mainly carbon, or more commonly, charcoal. The combustion of this material occurs on its surface and is recognized by an orange glow, indicating the combustion of carbon and oxygen at an elevated temperature level of 1300° F. plus (700 C). The charcoal contains as much as two-thirds of the wood's energy. After the charcoal is consumed, the material left (ash) is mainly inorganic material that cannot be burned further.

SECONDARY COMBUSTION

The volatile materials released from wood during Stage 2 must be burned in order to obtain the best possible heating efficiency and the greatest reduction in creosote formation and air pollution. The process of burning these materials is called secondary combustion.

Secondary combustion can occur in conventional stove or fireplace designs if fresh air is available and temperatures in excess of 1100° F. (600 C) are generated by the fire. The flaming you see above the logs in your WinterWarm is an uncontrolled type of secondary combustion.

Secondary combustion can occur at much lower temperatures and in a much more controlled manner in a properly designed and operated catalytic combustion system.

The WinterWarm

THE CATALYTIC SYSTEM

The components of the catalytic combustion system in your WinterWarm work together to promote ignition of smoke and gases at temperatures of about 500° F. to 600° F. (260 C to 315 C), roughly one-half the temperature normally required for secondary combustion.

Once catalytic ignition begins, heat conservation and recycling within the system itself will encourage complete combustion by further increasing temperatures. The system will be effective once the catalytic system has been activated, even when the appliance is operating at temperature ranges too low to sustain normal secondary combustion within the WinterWarm firechamber.

The **primary combustion chamber** is the cast iron chamber which contains the load of fuel and in which primary combustion takes place. The **secondary combustion chamber** is a rectangular baffled chamber located behind the WinterWarm's fireback. It is made of a high temperature **refractory material** which helps maintain elevated temperatures within the combustion zone and protects the cast iron from the extremely high temperatures generated by secondary combustion.

Gases released by primary combustion enter the secondary chamber through a **throat** at the rear of the primary chamber. Upon entering the refractory chamber, the gases pass through the **catalytic element**, a high temperature ceramic "honeycomb" coated with a catalytic material. **Directional baffles** improve combustion efficiency and direct exhaust out of the chamber.

The primary and secondary combustion chambers are separated by the cast iron fireback and an internal **bypass damper**. The damper can be set in two positions - open (updraft mode), and closed (high-efficiency mode). When the bypass damper is open, smoke exits to the chimney directly from the primary combustion chamber. When the bypass damper is closed, smoke is directed through the catalytic combustion system before exiting through the chimney.

COMBUSTION AIR

A bimetallic coil located on the upper left side of the WinterWarm controls the position of the primary air intake shutter. Primary air is delivered from the left side to the upper front through a series of cast iron air manifolds. The airwash manifold, located over the load door, serves as a reservoir for delivering a uniform sheet of air down over the glass panels. All of the cast iron manifolds serve the additional function of preheating the incoming air.

AIRWASH SYSTEM

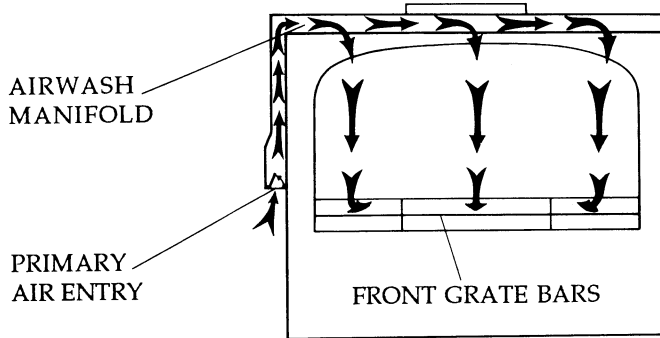

The automatic factory-set secondary air control meters the proper amount of air into the secondary air passageway depending on the temperature it senses within the combustion chamber. This helps compensate for the variable nature of wood combustion and will offset some (though not all) of the problems associated with burning inadequately seasoned ("green") wood.

SECONDARY AIR PATH

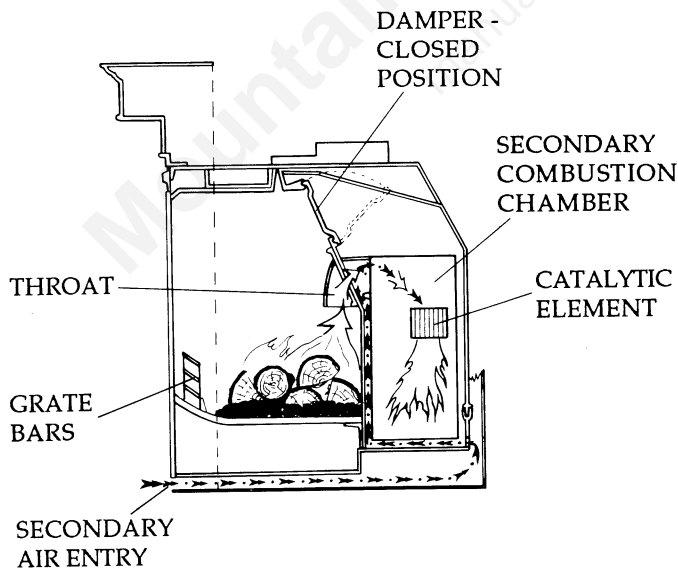

CONVECTION AIR

The by-products of combustion leave the secondary combustion zone at elevated temperatures. The heat exchange surface at the back of the WinterWarm ensures

maximum heat transfer to the convection air system while still allowing the exhaust entering the chimney to retain the heat necessary for maintaining proper draft. Convection air travels between the sheetmetal shroud and the firechambers, eventually entering the room through the top latticed panel.

Two speed-controlled fans greatly increase the volume of air passing through the convection air system. Mounted within each front column base, the fans operate in unison to draw air into the system. A variable speed control is provided to allow you to match fan speed to heat output. The fan speed should correspond to the primary air lever setting: the highest fan speed is used with high primary air settings, the lowest fan speed with low primary air settings, and so on. When set properly, the fans will operate to achieve the most efficient heat transfer and quietest operation. If the temperature at the base of the WinterWarm's primary combustion chamber drops below 100° F. (45 C), the fans automatically shut off. The fans come back on when the temperature increases.

CONVECTION AIR PATHWAY

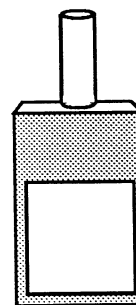
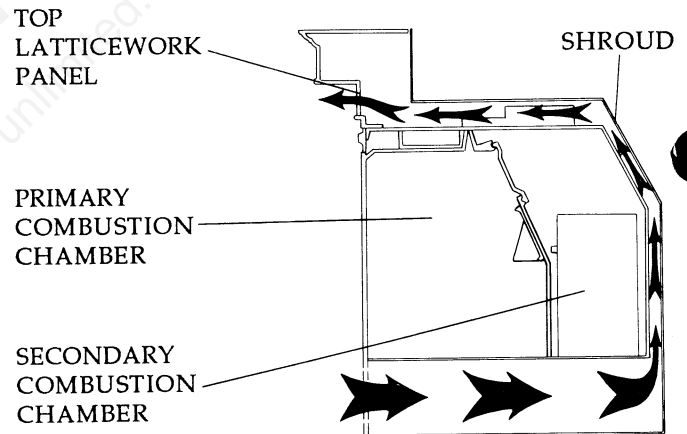

The Fireplace System cabinet provides a second convection air path. Elevation of the WinterWarm within the insulated cabinet allows introduction of a new supply of room air to the space below the elevation platform. The air enters through an opening in the plinth base, then circulates by natural convection around the WinterWarm shroud, capturing additional heat. Two air ducts convey the warmed air from the top of the cabinet to vents which can be located on the face or side of the installation chase. An optional fan, controlled by an independent switch, can be installed at the back of the chase to send a greater volume of heated air through this second convection system.

The Stages of Combustion During Daily Operation

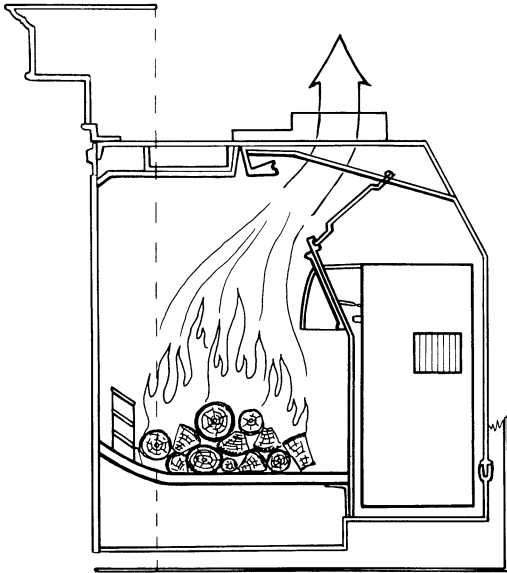

1. Kindle a fire. Damper is open. Thermostat lever set to admit large amounts of air. Warm up the WinterWarm and establish a charcoal bed which is 3" - 4" (80 mm. to 100 mm.) deep. This may require an hour or more from a cold start.

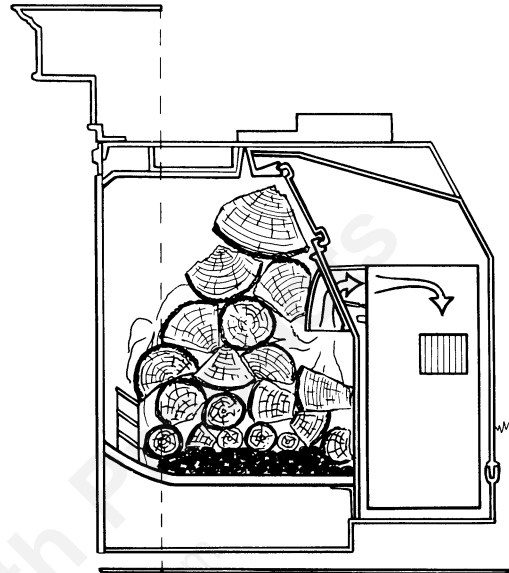

2. Charcoal bed is well established. Firechamber is loaded (smaller pieces on bottom), thermostat lever set to admit large amounts of air. Close damper when fuel has ignited, generally about 5 minutes. Volatiles released from fuel begin to burn in the catalytic combustion system.

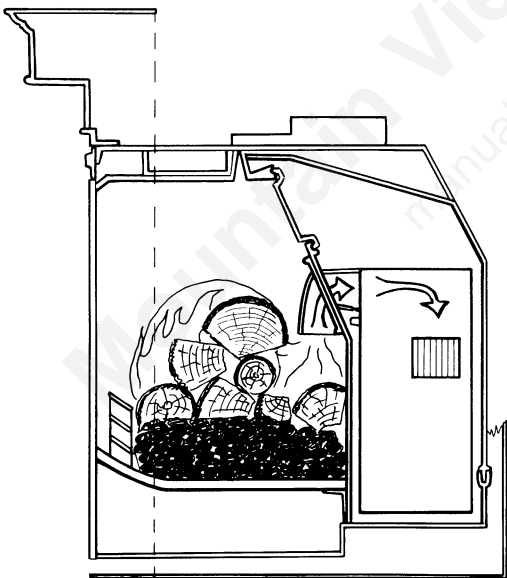

3. Fuel burning briskly. Thermostat and fan levers adjusted to give desired heat output level. Combustion of volatiles in catalytic combustion system continues. Flaming visible through glass doors at medium heat output level and above. Glowing coals at base of fire are visible at lower heat output level.

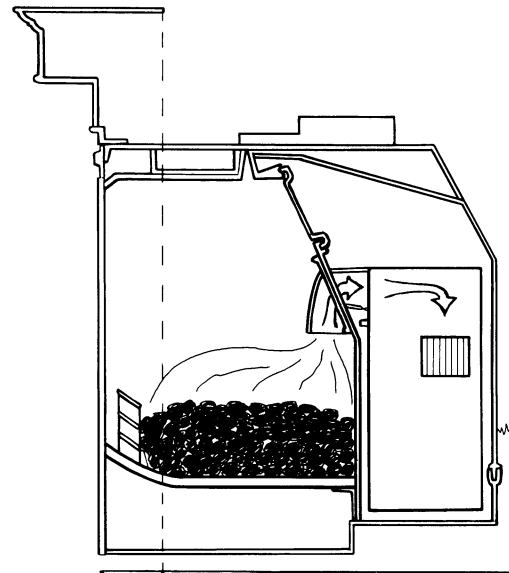

4. Charcoal burning phase. Almost all volatiles have been released and burned. Steady heat output continues for several hours. Orange glow visible through glass. Reload when the charcoal bed burns down to 3" - 4" (80 mm. to 100 mm.). Return to stage 2.

CUTAWAY VIEW OF THE WINTERWARM FIRECHAMBER

- | | |
|-------------------------------|---------------------------------|
| A. AIRWASH MANIFOLD | I. REFRACTORY MATERIAL |
| B. GLASS DOOR PANEL | J. CATALYTIC ELEMENT |
| C. FRONT GRATE BARS | K. BAFFLE |
| D. GRATE | L. SECONDARY AIR CONTROL |
| E. PRIMARY COMBUSTION CHAMBER | M. SECONDARY COMBUSTION CHAMBER |
| F. THROAT | N. ASHPAN |
| G. DAMPER | O. SHROUD |
| H. FLUE COLLAR | |

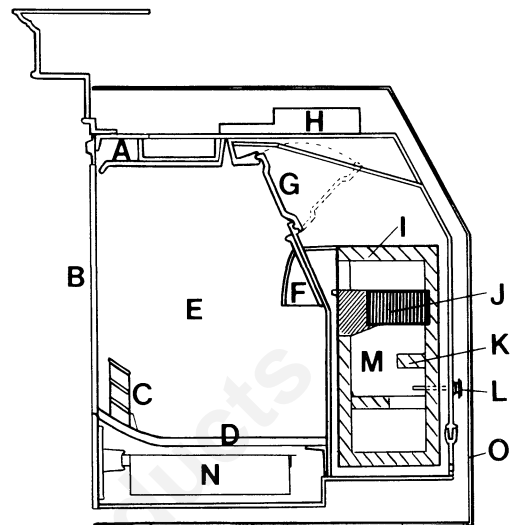

OPERATION

IMPORTANT

READ THIS SECTION CAREFULLY BEFORE YOU LIGHT YOUR FIRST FIRE. IT CONTAINS SAFETY RULES AND PROCEDURES THAT WILL HELP YOU OPERATE YOUR WINTERWARM™ SUCCESSFULLY. FAILURE TO HEED THESE INSTRUCTIONS CAN RESULT IN DAMAGE TO YOUR VERMONT CASTINGS WINTERWARM™ AND MAY VOID YOUR WARRANTY.

As the lighter, more buoyant gases rise up the chimney, draft causes a flow of cooler air into the WinterWarm. When starting a fire in a cold firechamber on an unheated chimney, it may be necessary to preheat the system by igniting several sheets of crumpled newspaper which have been placed in the flue collar area.

There are other factors which influence draft, such as barometric pressure, wind speed and direction, the height, configuration and size of the chimney, and the airtightness of the home itself.

Chimneys and Draft

BASICS

Understanding how your chimney contributes to operation is essential if you are to obtain optimum performance from your WinterWarm. The chimney provides a safe pathway for hot smoke and exhaust gases to exit from the appliance, but in addition, the chimney strongly influences the "draft" necessary for operation.

Draft is the force which produces a flow of warm gases up and out of the chimney, and draws fresh combustion air into the WinterWarm. Your WinterWarm does not come equipped with "draft". Draft is created by a difference in weight between the gases inside the chimney and gases outside the chimney. Because gas expands when heated, a given volume of warm gas inside the chimney weighs less than the same volume of cool gas outside. This weight difference creates the pressure necessary to produce and sustain draft.

OUTSIDE AIR

In some modern, super-insulated homes, the air necessary for combustion is inadequate due to restricted air infiltration. (Infiltrated air is simply that air which finds its way into a home through various cracks and openings in the foundation, along windows and doors, and at other areas which are not weathertight.) The situation is aggravated further if the WinterWarm is competing with kitchen or bath exhaust fans for available air. Where poor draft is the result of a low infiltration rate, opening a ground floor window in the vicinity of the WinterWarm, or installing a permanent outside air supply, will often alleviate the problem.

In some areas, bringing air for combustion from outside the home directly to the air inlet of the appliance is required. When the air supply for the fire is brought directly from the outside, it is not affected by variations in air pressure within the house. Improved performance often results. Outside Air Adaptor Kits are available for both the WinterWarm Fireplace Insert and the WinterWarm Fireplace System.

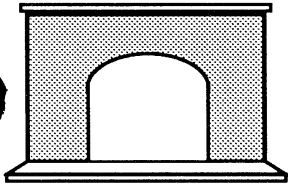

When using an Outside Air Kit in a WinterWarm Fireplace Insert installation, it is usually necessary to modify the masonry fireplace structure. It is important

that you receive expert advice before proceeding with such an installation. Be sure to consult with your local building code inspector and Vermont Castings Authorized Dealer before making any changes to your masonry fireplace.

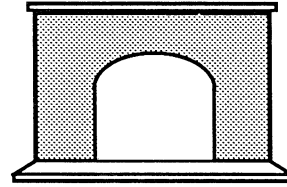

Following Vermont Castings' recommendations on chimneys (outlined in the Installation Manual for the WinterWarm Fireplace Insert) will help ensure that your Insert and fireplace chimney are properly matched. Your Vermont Castings Authorized Dealer can help you assess your existing fireplace and chimney, and suggest any modifications which may be necessary.

EFFECTS ON OPERATION

A strong draft will allow you to successfully fine-tune the WinterWarm's performance by adjusting the primary air supply to regulate the rate of combustion and heat output. With a strong draft, you can restrict the primary air supply and lower the heat output without risk of suffocating the fire.

A strong draft will be maintained by operating your WinterWarm so that combustion gases entering the chimney are hot, and stay hot. No air must be allowed to enter the chimney without first having passed through the WinterWarm.

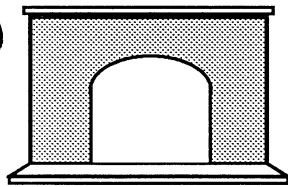

Make sure that any clean-out doors and unused thimbles are sealed tightly with masonry, and that the fireplace chimney is structurally sound.

Low draft situations are characterized by smoking and odor problems in the house, low heat output, and difficulty maintaining a fire, especially at low thermostat settings. The reverse situation, overdraft, is rare, but can be recognized by short burn time, poor response when trying to slow down the fire, or by any part of the WinterWarm glowing red. (The more common cause of overdraft symptoms, however, is poor maintenance. Following recommended maintenance procedures will ensure consistent performance.)

The chimney's flow capacity (which measures the ability of the chimney to evacuate combustion gases quickly) is also important. Even the strongest draft cannot overcome an insufficient flow capacity; the result is a backup of combustion gases in the chimney which forces smoke out of chimney connector joints or the WinterWarm itself. Remember, the WinterWarm and the chimney function as a unit. For optimum performance, they must be sized properly for each other.

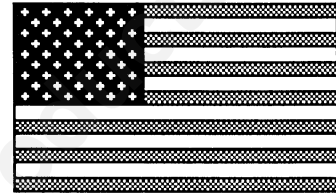
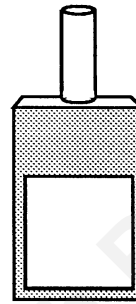

The WinterWarm Fireplace System has been carefully tested to perform efficiently with five brand-name prefabricated chimney systems. The Installation Manual for the WinterWarm Fireplace System and your local Vermont Castings Authorized Dealer will provide you with detailed information.

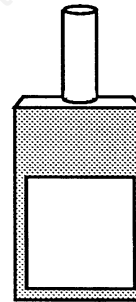

The WinterWarm Fireplace System may be used with any prefabricated chimney tested and listed to the high temperature (650 C) standard, ULC S-629. The Installation Manual for the WinterWarm Fireplace System or your local Vermont Castings Authorized Dealer can provide you with detailed information.

The Controls

Your WinterWarm is equipped with controls for thermostat setting, fan speed, and damper position. By changing the settings for these controls, you can achieve a range of heat outputs, allowing you to tailor your WinterWarm's performance to weather conditions and personal comfort requirements. The brass control knobs are conveniently mounted in the top latticework panel.

THE THERMOSTAT

The **thermostat lever** is located at the upper left of the top latticework panel. It provides manual control of the primary air supply. When the control lever is moved to the left, the primary air shutter opens to admit more air, increasing the rate of combustion and heat output. When the control is moved to the right, the primary air shutter closes to restrict air entry, slowing the rate of combustion, and reducing the heat output. The thermostat lever may be set anywhere between the settings of high and low to provide a wide range of combustion rates and heat outputs.

WINTERWARM CONTROLS

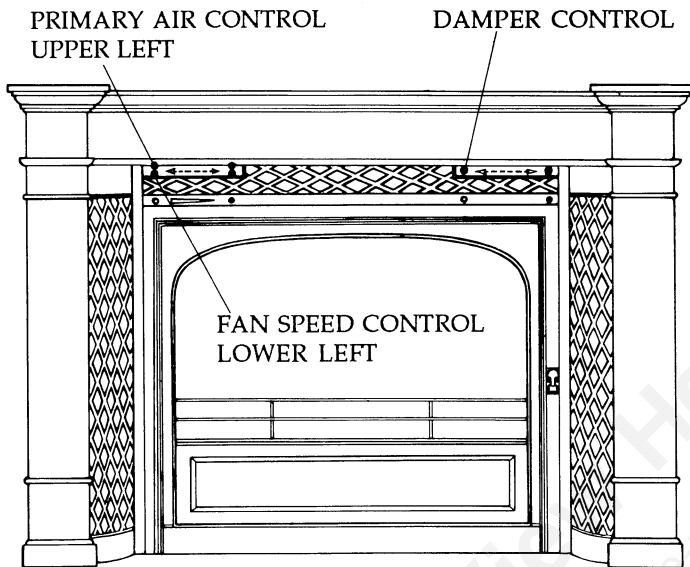

In addition to manual control of the primary air supply, automatic control is provided by a **bimetallic coil** which acts to maintain the manually selected heat output. As the WinterWarm gets hotter, the coil gradually relieves the tension on the thermostat chain, causing the **air shutter** to close. The restricted air supply slows the rate of combustion. As the WinterWarm cools, the coil slowly increases the tension on the thermostat chain and opens the air shutter. The additional air increases the rate of combustion. This action of the coil continues throughout the burn cycle and promotes an even heat output from the WinterWarm.

THE FANS

The two column base fans are operated by a lever located on the lower left of the top latticework panel. The fans are off when the lever is at the farthest left position. Immediately to the right of the "off" position, the fans will operate at maximum speed. The lowest "on" setting occurs with the lever at the farthest right position. The fans may be set anywhere in between the high and low extremes. Always match fan speed to your thermostat setting to achieve efficient operation of your WinterWarm. For example, when the thermostat lever is set for a low heat output, the fans should also be set at

low. When operating at high heat outputs, operate the fans at high speed.

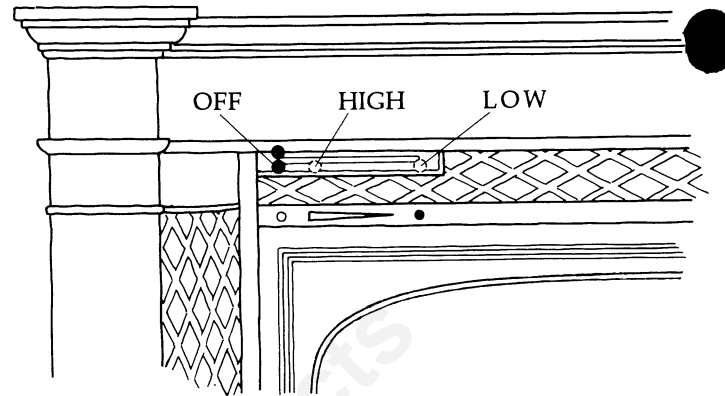

These fans will shut off automatically when the temperature in the floor of the firechamber drops below 100° F. (45 C).

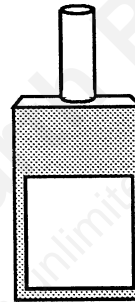

If you are using the optional cabinet convection fan, operate it using the control installed specifically for that fan. This fan **will not** shut off automatically. When the unit is cold or not in use, make sure the control is turned to the "off" position.

THE BYPASS DAMPER

The bypass damper is operated by the lever located at the upper right of the top latticework panel. The damper is open (updraft mode) when the lever is in the far left position. The damper is closed (high-efficiency mode) when the lever is to the far right. In the closed position, the front load door is locked, ensuring that you do not inadvertently open the door during high-efficiency burns and spill smoke into the room. To open the damper, lift up on the lever and move it to the far left. The door/damper interlock mechanism will disengage, allowing you to open the front door. There are no intermediate settings for damper position. To close the damper, move the lever to the right, continuing past the resistance to lock the damper in position. If you experience difficulty reaching the locked position, check the load door handle. It must be in the closed position (fully vertical) before the door/damper interlock mechanism will engage.

Fuel

The fuel you use makes an important contribution to successful operation. You will experience the best performance and overall efficiency by burning firewood that has been split, stacked and air-dried for about one year. Burning insufficiently seasoned or "green" wood

will lower the performance level of your WinterWarm and make more work for the operator. With excessively dry wood, on the other hand, the operator may have difficulty keeping the heat output at a moderate level.

The Vermont Castings WinterWarm is designed to burn solid wood. The wood should be cut into 20" to 24" lengths (500 mm. to 600 mm.), split, and stacked. The top of the stack should be covered to keep off rain or snow, but the sides left uncovered for air circulation which aids in drying. The stack is then left to season for a year or so before burning.

To ensure safe and efficient combustion, wood must always be positioned behind the front grate bar. The WinterWarm will accommodate the longer 24" (600 mm.) pieces in the front of the firebox, while the 20" (500 mm.) pieces will fit comfortably in the rear. No wood or other combustible material should be stored within 48" (1200 mm.) of the front face of the WinterWarm.

The Break-In Fires

Cast iron is a superior material for wood heating appliances, but it must be treated with respect. It can be broken with a sharp blow from a hammer or from the thermal shock of very rapid temperature changes. Since cast plates expand and contract with changes in temperature, allow them to adjust gradually to minimize the stresses. A little extra care and thoughtfulness during the break-in period will help promote a long life for your WinterWarm.

WARNING: FIREPLACES EQUIPPED WITH DOORS SHOULD BE OPERATED ONLY WITH DOORS FULLY OPEN OR DOORS FULLY CLOSED. IF DOORS ARE LEFT PARTLY OPEN, GAS AND FLAME MAY BE DRAWN OUT OF THE FIREPLACE OPENING, CREATING RISKS OF BOTH FIRE AND SMOKE.

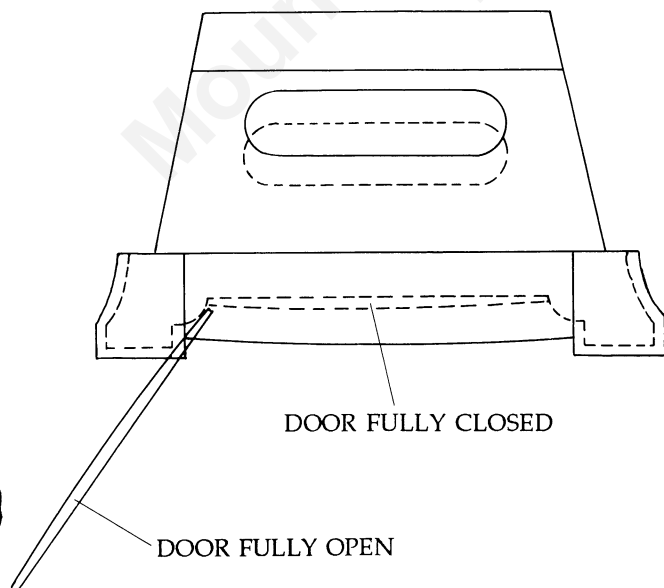

Follow these guidelines to break in your WinterWarm firechamber properly:

- Open the damper. Open the load door. Set the thermostat lever on high.
- Lay some crumpled newspaper and kindling on the bottom grate. Place some dry, finely split kindling on top of the paper, followed by two or three pieces of 1" - 2" (25 mm. to 50 mm.) split, dry wood. Light the fire. The load door may be fully open or fully closed. If your chimney is cold, you may have to prime it by igniting a crumpled piece of newspaper which has been placed up into the flue collar area behind and above the WinterWarm damper frame.
- Gradually build up the fire by adding a few 3" - 5" (80 mm. to 125 mm.) diameter splits. Keep the load door closed.
- Control the size of the fire by adjusting the thermostat lever.
- Allow the fire to burn brightly, and then let it die out. Allow the WinterWarm to cool.
- Repeat this small to moderate fire a few times before proceeding to higher heat output fires or the high-efficiency mode. Each successive fire may be slightly hotter and longer.
- Do not close the damper during break-in fires unless you have built up a bed of coals on the grate.

Daily Operation

STARTING THE WINTERWARM

Once your WinterWarm has been properly broken in, you should start operating in the high efficiency mode. Begin by building a fire just as you did for the break-in fires. A strong kindling fire of dry wood preheats the system quickly. It is a good idea to store your kindling in a warm, dry place before burning it.

Once your fire is burning steadily, continue adding split 3" - 5" (80 mm. to 125 mm.) pieces of wood until you have established a bed of hot coals 3" to 4" (80 mm. to 100 mm.) thick on the grate. Control the size of the fire with the thermostat lever; avoid the extremes of a roaring blaze or a slow smoky fire. Building a bed of coals on the grate may take an hour or more depending on the type of firewood being burned, the moisture content of the wood, and the draft in the chimney. A charcoal bed of 3" - 4" (80 mm. to 100 mm.) is required for proper operation in the high-efficiency mode.

Add more wood to the WinterWarm, being sure to keep the fuel load behind the front grate bar. Increase the amount of fuel as you become familiar with your WinterWarm and the heating requirements of your home. A very full load will enable you to increase the heat output and length of burn. Close the damper to direct the smoke through the catalytically enhanced secondary combustion system when you have an adequate coal bed and a new load of fuel has ignited.

Leave the thermostat lever on high for five to

fifteen minutes after you close the damper. This will allow the hot smoke to heat the secondary combustion chamber thoroughly so that catalytic activation is achieved. Once the catalytic system is thoroughly heated, adjust the thermostat and fan levers to provide the desired heat output.

CAUTION: The WinterWarm is a powerful heater. Avoid contact with all surfaces while the WinterWarm is in operation. Keep children, clothing, and furniture away in order to avoid injury or damage due to burns.

RELOADING THE WINTERWARM

Time spent tending your WinterWarm will be greatly reduced if you reload it while the system is still hot and there is plenty of charcoal. Including some smaller pieces of wood in the new load of fuel also will help the WinterWarm regain high temperatures quickly.

Follow this procedure when you reload your WinterWarm:

- Open the damper.
- Set the thermostat lever on high.
- Open the load door.
- Check the ash level in the ashpan, and empty if necessary. Replace the ashpan.
- Load wood, smaller pieces first.
- Close the load door.
- The WinterWarm must rebuild its thermal momentum. Leave the damper open and thermostat lever on high for five to fifteen minutes.
- Close the damper. Allow the WinterWarm to operate with the thermostat on high for five to fifteen minutes.
- Adjust the thermostat and fan levers for the desired heat output.
- NOTE: If the remaining charcoal bed is relatively thick and if your fuel is well seasoned, it is possible to add fresh fuel (smaller pieces first), close the door and damper, and reset the controls within five minutes.

The WinterWarm is not an incinerator, and should not be used to burn household trash. Flammable liquids should never be burned in the WinterWarm.

NEVER USE GASOLINE, GASOLINE-TYPE LANTERN FUEL, KEROSENE, CHARCOAL LIGHTER FLUID, OR SIMILAR LIQUIDS TO START OR "FRESHEN UP" A FIRE IN THIS HEATER. KEEP ALL SUCH LIQUIDS WELL AWAY FROM THE HEATER WHILE IT IS IN USE.

OVERFIRING

An overfiring condition is indicated if any part of the WinterWarm glows red. Overfiring can be caused by:

- Burning materials other than wood, or

- Operating the WinterWarm with the front door partially open, or
- Poor maintenance.

Overfiring can create hazardous conditions within the system. Damage to the firechamber can occur and will void your warranty.

THE DOOR

Your Vermont Castings WinterWarm is equipped with a large expanse of clear glass which provides maximum fireviewing area. While the glass is sturdy, it still must be protected from sharp impacts. Never slam the door. Be careful not to strike it with a piece of wood when loading.

From time to time you may wish to use the cassette screen, which is standard equipment on your WinterWarm, to enjoy open fire burning. The glass cassette and screen cassette are interchangeable, and allow you the option of quickly converting from closed door burning to protected open fire burning.

To change cassettes, use the following procedure:

- Make sure the WinterWarm is thoroughly cool.
- Open the door.
- Loosen the two short retainer clips, one at each top corner of the cassette frame, and turn them to clear the frame.
- Tilt the top edge of the cassette away from the door frame.
- Carefully remove the cassette. Be especially careful with the glass cassette. Store the unused cassette for future use.
- Examine the gasketing which seals the cassette to the perimeter of the door frame. Contact your local Vermont Castings Authorized Dealer if you need replacement gasketing.
- Check the bottom channel of the door frame for debris, and clean if necessary.
- Insert the new cassette, bottom edge first, then the top edge.

IMPORTANT: The glass used in your WinterWarm is coated with a special material on one side which reflects heat back into the firechamber. Before reinserting the glass cassette, first examine the metal frame. On one side, you will see smooth mitered corner joints and on the other, rough weld marks. The rough weld marks should be positioned toward the gasket material. The smooth mitered corners should be positioned toward the firechamber.

- Replace the two retainer clips, being sure to apply just enough pressure to snug the cassette evenly against the gasket.

NOTE: The WinterWarm must always be operated with the bypass damper open when using the open fire (screened) mode.

ASH HANDLING

Ash removal will be required every two or three days during normal operation. Many of the ashes will fall through the grates during the course of a burn cycle. When the WinterWarm is being reloaded, use a slicer or poker to stir the coals on the grate. Every few days clear ash from the outside edges of the firebox, and while the ashpan is removed, clear any ashes which have fallen into the ashpan chamber.

IMPORTANT: Check the level of ashes in the ashpan before reloading the WinterWarm. If the ashes are close to the top edge of the pan, it is time to empty the pan. By emptying the ashpan before clearing ashes through the grate and reloading the WinterWarm, you will avoid having to handle an ashpan full of hot coals. Use extra care and wear heavy stove gloves if it is necessary to handle the ash when it contains hot coals.

To check the ash level in the ashpan or to empty the ashpan:

- Open the damper.
- Open the load door.
- Insert the edge of the ashpan cover behind the ash chamber door.
- Swing open the door.
- If the ash level is nearing the top, place the removable cover over the pan.

- Take the pan outdoors and empty the ashes into your ash container.
- Replace the ashpan and close the ash and load doors.

Ashes should be placed outside in a metal container with a tight fitting lid. The closed container of ashes should be placed on a noncombustible floor or on the ground, well away from all combustible materials, pending final disposal. If the ashes are disposed of by burial in soil or otherwise locally dispersed, they should be retained in the closed container until all cinders have thoroughly cooled. The ash container should not be used for disposal of any other material.

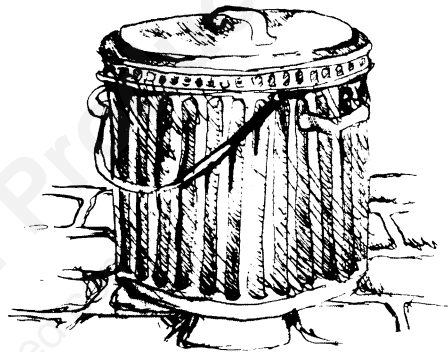

MAINTENANCE

The benefits in superior performance and safety that good maintenance bring are well worth the short time required. These guidelines will help you keep your WinterWarm in top shape.

The fire must be out and the WinterWarm cool before beginning maintenance procedures. A strong light will be helpful as you inspect and maintain your Insert or Fireplace System. Safety goggles, a particle mask, and heavy work gloves are recommended whenever you work on your WinterWarm.

Basics

CLEANING

CAST IRON: An occasional dusting with a soft dry brush is usually all that is necessary to keep your WinterWarm looking new. From time to time, you may wish to go over the cast iron surface with a damp cloth; do this while the cast iron is cool, and make sure no water remains on the surface.

If the paint needs retouching, allow your

WinterWarm to cool completely. Brush any areas needing attention with a wire brush, and make sure the entire surface is clean and dry. Touch up the surface with Vermont Castings High Temperature Stove Paint. Apply the paint sparingly. Two light coats are better than one heavy one.

PORCELAIN ENAMEL: Use a soft brush as necessary. Do not use water or other liquids on your WinterWarm. Fingerprints usually can be buffed off porcelain enamel with a dry, soft cloth. If marks remain, allow the WinterWarm to cool completely, then buff with a slightly damp, soft cloth. Dry completely before starting a fire to avoid streaking.

Never use abrasives or harsh chemical cleaners on the porcelain enamel finish. The enamel may scratch and expose the cast iron, which can then stain or rust. If you must remove spills or stains from porcelain surfaces, make sure the fire is out and the WinterWarm is completely cold before cleaning. Use **ONLY** a kitchen appliance cleaner and polish especially formulated for enamel surfaces. Apply cleaner sparingly with a soft cloth, and buff away **ALL** traces of the cleaner.

DOOR LATCH

The front door of the WinterWarm should close securely (to prevent accidental opening) and tightly (to prevent air from leaking into the firechamber) when the handle is in the closed position.

In the closed position, the handle will be straight up and down; it should resist slightly as it is closed and the door should pull in snugly.

Over a period of time, gasketing around the door will compress and the latch may need adjustment. To adjust the handle, loosen the small locking nut, extend the striker screw one turn, and retighten the small locking nut while preventing the striker screw from turning. Keep making adjustments a little at a time until the setting is right.

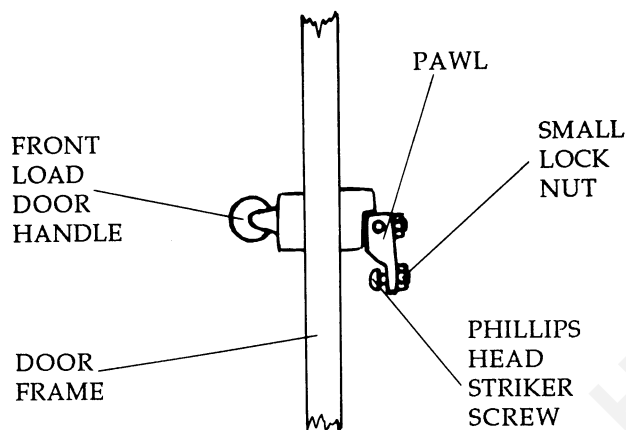

Glass Door Panel

CLEANING

The WinterWarm glass system is designed so that during normal operation you may enjoy the view of the fire for extended periods without experiencing carbon build-up on the glass. Most carbon deposits which accumulate will usually burn off during hot fires.

The ash residue which accumulates on the glass surface, however, should be removed periodically to prevent etching. To clean the glass, follow this procedure:

- Be sure the glass is completely cool.
- Wash the glass with water. No abrasives or special glass cleaners are needed.
- Rinse the glass thoroughly.
- Dry the glass completely.

REPLACEMENT

Do not operate the WinterWarm with a damaged glass (or screen) cassette. Use the following procedure for cassette replacement. NOTE: replace glass only with Vermont Castings high temperature ceramic glass, available from your Vermont Castings Authorized Dealer.

- Open the door and loosen the two retaining clips,

one at each upper corner, which hold the cassette to the door frame. Swing the clips out of the way. Tilt the cassette away from the door frame and lift up. Use caution when handling a cassette which contains broken glass.

- Examine the gasketing which seals the cassette to the door frame. Replace if necessary with gasketing obtained from your local Vermont Castings Authorized Dealer.

- Check the channel at the bottom of the door frame, and clear away debris if necessary.

- Examine the new glass cassette. Note that the corners of the metal frame are smoothly mitered on one side, and rough on the other. Install the new cassette in the door frame so that the smooth mitered corners are towards the firechamber, and the rough welded corners are towards the gasket.

- Secure the clips, being careful not to overtighten. Be sure the cassette is firmly seated against the gasket.

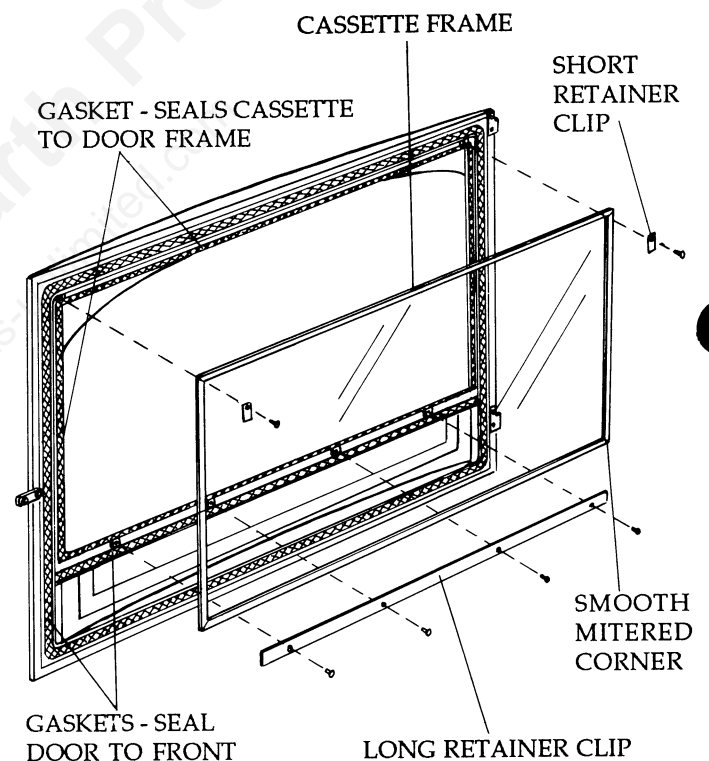

REMOVING THE DOOR

The WinterWarm's door may be removed if necessary by opening the door and lifting straight up. The door will lift off its hinge pins. Be careful if you must remove the door, as it is heavy.

Column Blower Access

CAUTION: Disconnect the power supply to the blowers before proceeding with any necessary service.

- Remove the outer cast iron curved lattice panel by lifting up and pulling out at the bottom.
- Loosen the hex head cap screw that secures the retainer tab to the column base.

- Swing the tab off of the wire mount.
- Lift up slightly on the front corner of the horizontal air divider and slide the fan clear of the column base.
- Disconnect the two wire leads protruding from the top corner of the fan.

Catalytic Element

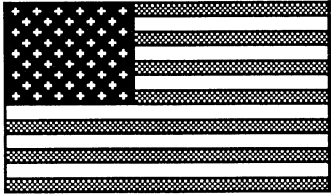

This wood heater contains a catalytic combustor, which needs periodic inspection and replacement for proper operation. It is against the law to operate this wood heater in a manner inconsistent with operating instructions in this manual or if the catalytic element is deactivated or removed.

Under normal operating conditions, the catalytic element should remain active for 2 - 6 years (depending on how much wood is burned). Regular inspections of the chimney and flue connector are a good way to assess the performance of the catalyst. Using a mirror and strong light, sight up the flue collar and examine the connector for deposits.

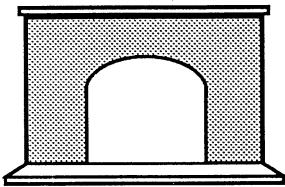

If you cannot sight up through the flue collar, you must remove the WinterWarm from the fireplace to examine the chimney system components.

Loss of catalytic activity will become apparent during these inspections if the amount of creosote in your chimney and/or connector components increases significantly. The catalyst itself should be examined for physical damage and clogging three times per year. It is not necessary to remove the catalyst each time unless you find it in need of cleaning. To examine the element, follow these steps:

- Remove the throat pieces by tapping upward at the far left and right corners with a soft-faced hammer.
- Examine the catalytic element, which is now visible. If you wish, use a small mirror and flashlight to aid in your inspection.
- Unless the catalytic element shows a heavy fly ash accumulation or major damage, do not remove it. Instructions for removal are given later in this section.
- Replace the throat pieces. Seat the top center

edges first, then slide the outer edges into position, following the plane of the damper frame. Once the wedges engage, tap downward until the throat is horizontal.

If you notice poor performance in your WinterWarm, follow these steps to pinpoint the cause:

1. Assess your present operating conditions. Some factors which may cause a change in performance are changes in the wood supply (wood heaters usually burn better with seasoned wood), changes in the outside temperature (wood heaters usually burn better in colder weather), and changes in the direction of the prevailing wind.

Any changes in operating routine should be considered at this time as a possible reason for changed performance. In Spring or Fall, draft strength is less than in the middle of winter, and there is often a change in performance. Small hot fires work well in moderate weather. Review the Operation and Maintenance sections in this manual for tips on how to get the best performance from your WinterWarm.

2. Should all operating conditions seem consistent with previous experience, remove and inspect the catalytic element using the following procedure:

- Remove the throat pieces from the fireback.
- Remove the front grate bar.
- Remove the grate.
- Tip the lower fireback forward, and remove it by lifting it up and toward you.
- Carefully remove the refractory catalyst access panel.
- Slide the catalytic element out. Handle carefully — the element is fragile.

REMOVING THE REFRACTORY COVER

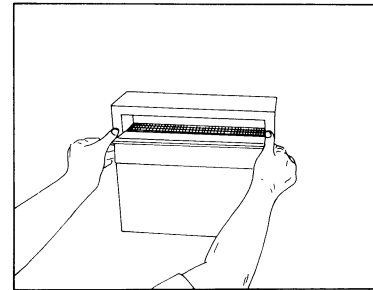

REMOVING THE CATALYTIC ELEMENT

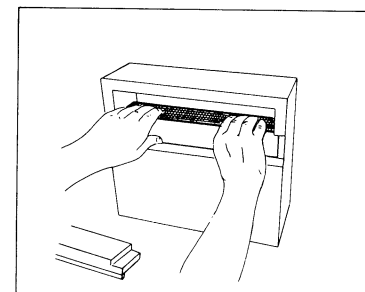

- Check the element for a build up of fly ash. Loss of performance may be due to a build up of fly ash on the catalyst surface.

- If the honeycomb is clogged, take the element outside for cleaning. A sizeable quantity of ash may be removed from the element. Blow gently through the honeycomb. Inspect the element. Although small hairline cracks will not affect performance, the element should be essentially intact. If elements are broken in pieces or have sections missing, they should be replaced. Call your local Vermont Castings Authorized Dealer for information about a replacement element, item #160-2505.

- If the element appears to be in good shape and all the fly ash has been removed, replace the element in your WinterWarm. Slide the element carefully back into the refractory chamber, seating it securely. The element must be fully to the rear of the support slot.

- Install the access panel, making sure that it is flush with the outer surface of the main refractory package.

- Check the slot in the rear bottom plate for debris, and clean if necessary.

- Reinstall the lower fireback by inserting the base of the fireback in the slot. Tip the fireback up into place.

- Reinstall the throat pieces, center edges first, then outer edges. Tap the throat pieces downward firmly to seat the lower fireback.

- Replace the grate.

- Replace the front grate bar.

- Clean the chimney and chimney connector.

- Operate the WinterWarm in typical manner for two weeks. Inspect the connector frequently during this period.

- A significant reduction in the observed creosote build-up rate is a good indicator that the performance change was due to fly ash deposits on the catalytic element. Continue with regular chimney system inspections to ensure proper performance is being maintained.

- Continued observation of significant creosote build-up is a good indicator that the catalytic element needs to be replaced. Contact your nearest Vermont Castings Authorized Dealer for information about a replacement element.

NOTE: Use only the replacement catalysts supplied by Vermont Castings.

Gaskets

The gaskets used when building your WinterWarm play an important part in ensuring that it provides consistent, reliable performance. Inspection of the gaskets and replacement when necessary is an important part of routine maintenance. Gasketing is used to seal passages so that the air and combustion gases flow along the proper pathways.

All the gaskets are made of a fiberglass material, and are secured with Vermont Castings High Temperature Stove Gasket Cement. All gaskets are accessible for replacement without withdrawing the WinterWarm from the cabinet or fireplace, with the exception of the flue collar gasket in the top plate.

Each time you change cassettes, examine the catalytic element, or remove or replace parts is a good time to examine the exposed gasketing. Pay particular attention to any point where a continuous gasket meets itself. Light colored streaks on the WinterWarm near the door may indicate air leaks due to worn or damaged gasketing. While minor leaks may be repaired by building up the gasketing in just the area of the leak, it is usually better to replace the entire door gasket. Your local Vermont Castings Authorized Dealer can supply the proper size replacement.

The gasket seals between parts which move frequently or play a critical role in ensuring that the correct amount of air enters the WinterWarm are especially important and must be checked regularly. These are the gaskets used:

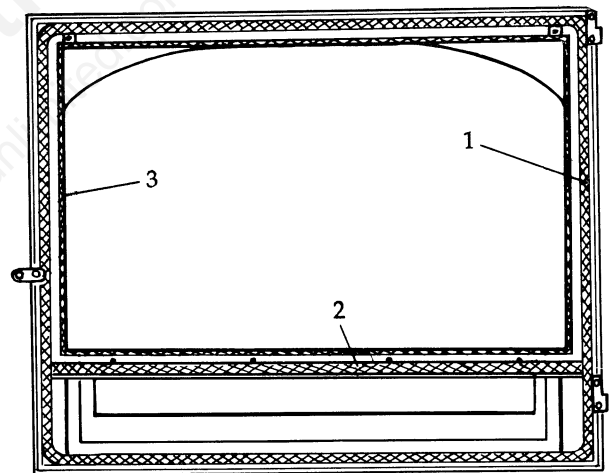

- 1. To seal the four sides of the load door to the WinterWarm's front (1/2" diameter).

- 2. To seal the load door to the front edge of the grate (1/2" diameter).

- 3. To seal the cassette to the load door (3/16" diameter).

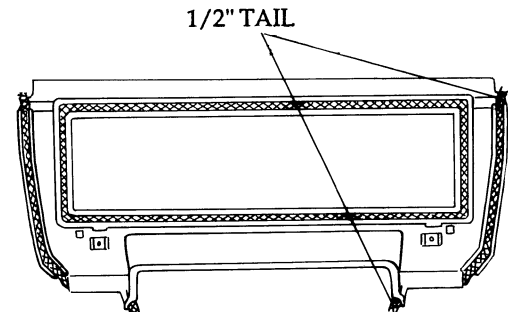

-To seal the bypass damper to the upper fireback when the bypass is closed (5/16" diameter).

Additional gaskets which form seals between non-moving parts are not as prone to wear or deterioration. If for any reason, however, your WinterWarm is disassembled, check the gaskets used:

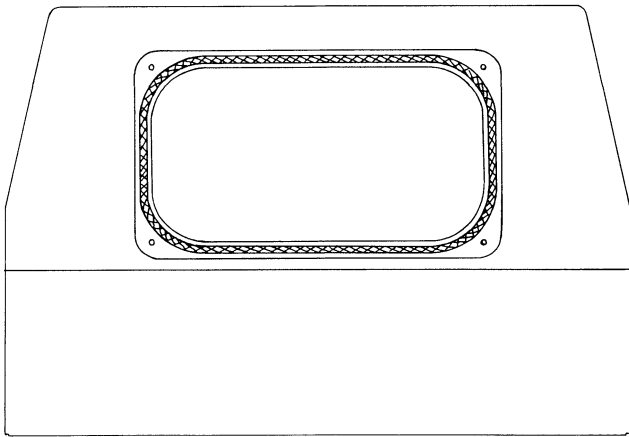

-To seal the reversible flue collar to the top plate (5/16" diameter).

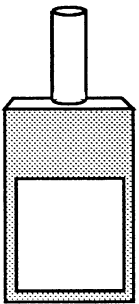

The flue collar is not reversible in the Fireplace System. It must always remain in the rearmost position.

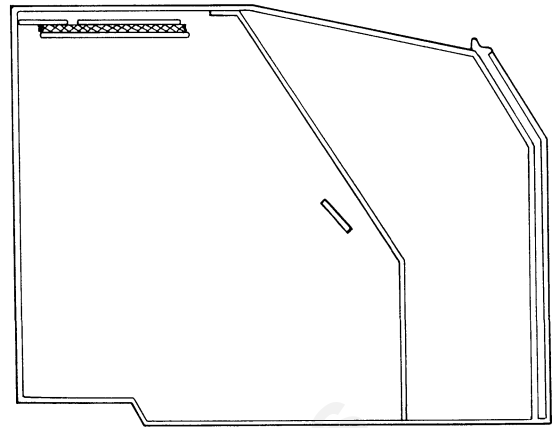

-To seal the left end of the firechamber to the left end of the air manifold (5/16" diameter).

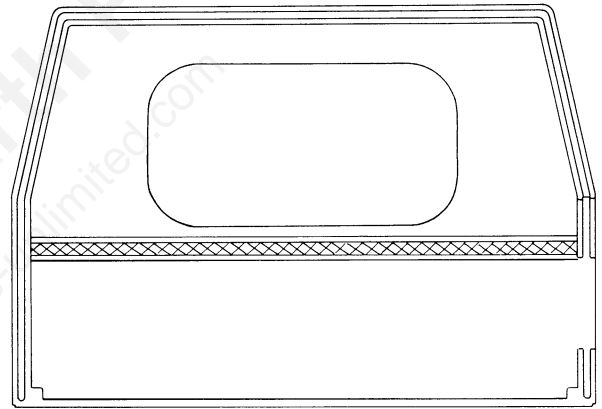

-To seal the underside of the top plate to the top edge of the air manifold (1/2" diameter).

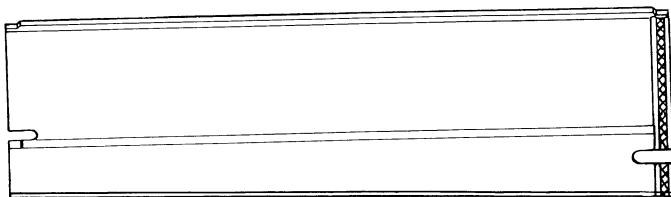

-To seal the right end of the air manifold to the right side plate (5/16" diameter).

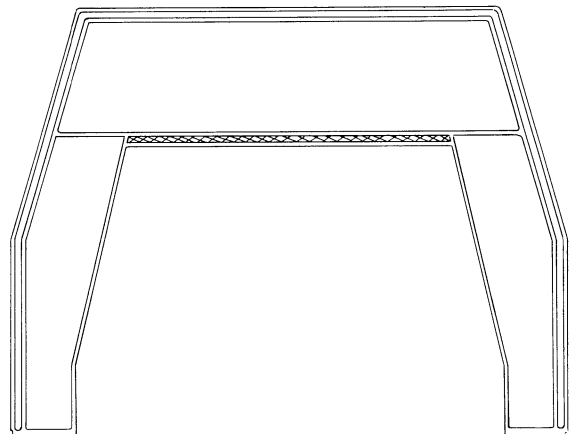

-To seal the bottom edge of the lower fireback to the bottom plate (5/16" diameter).

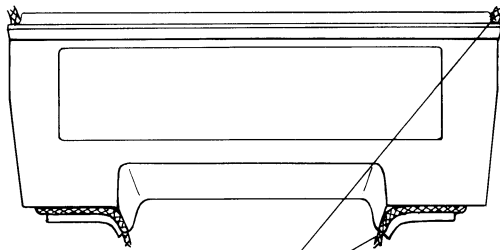

1/2" TAIL

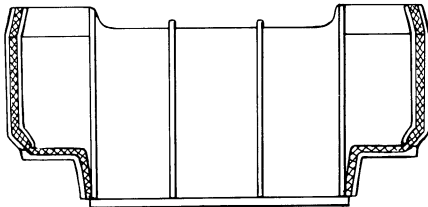

-To seal the ends of the upper fireback to the lower fireback and to the ribs of the right and left side plates (5/16" diameter).

Follow this procedure to replace worn gaskets:

- Remove the old gasketing.
- Clean the gasket channel with a wire brush.

Remove any stubborn deposits with a small cold chisel.

- Clean all parts to be gasketed.
- Cut the appropriate size gasket to length, allowing yourself an inch or two excess.
- Place an unbroken 1/8" (3 mm.) bead of gasket cement in the channel to be gasketed.

• Starting with one end, press the gasket into the cemented channel. If the gasket meets itself, ensure that you have a good joint before trimming the excess gasket. Leave 1/2" tails where shown in the illustrations. Do not overlap, or leave ragged edges.

• If possible, seat the gasket by placing it firmly against its normal mating surface. Clean away any excess cement.

- Allow to dry.

Damper Adjustment

The WinterWarm bypass damper should be examined after the first 50 hours of burning and adjusted, if required, to ensure a good seal. Periodic checks and adjustments thereafter should be a regular part of maintenance. To check the damper, first allow the fire to go out and the WinterWarm to cool. Open the front load door, and close and lock the damper. Visually inspect the seal between the damper plate and the damper frame; there should be no gaps. Now push gently on the damper — there should be some give, but no rattle. If there is a gap in the seal or a rattle, you should adjust the damper.

There are both fine and coarse damper adjustments. Begin with the fine adjustment, which modifies the pressure on the damper plate directly; it will take care

of most sealing problems. Proceed to the coarse adjustment, which adjusts the pressure at the damper latch, only if you cannot achieve a satisfactory seal with the fine adjustment.

Fine adjustment:

- Open the load door.
- Close and lock the damper.
- Loosen the lock-nut on the damper adjustment set-screw located in the center of the damper plate.
- Turn the set-screw 1/4 to 1/2 turn clockwise.
- Check the damper seal for gap or rattle.
- When the set screw position provides a good seal, tighten the lock nut. Be careful not to overtighten the set screw.

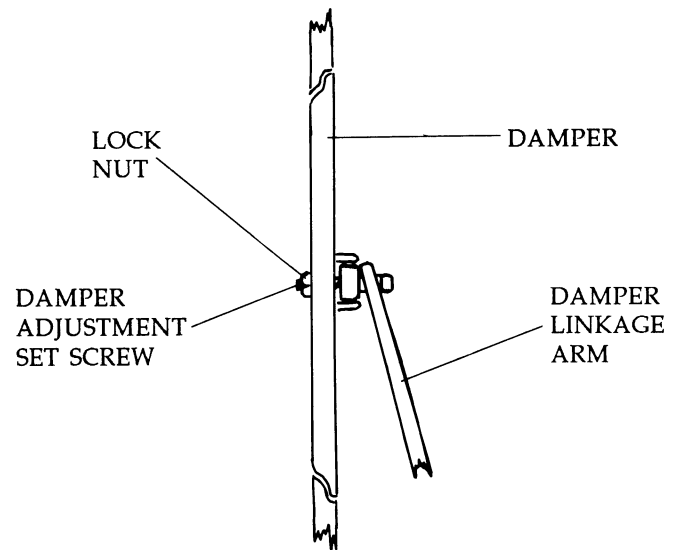
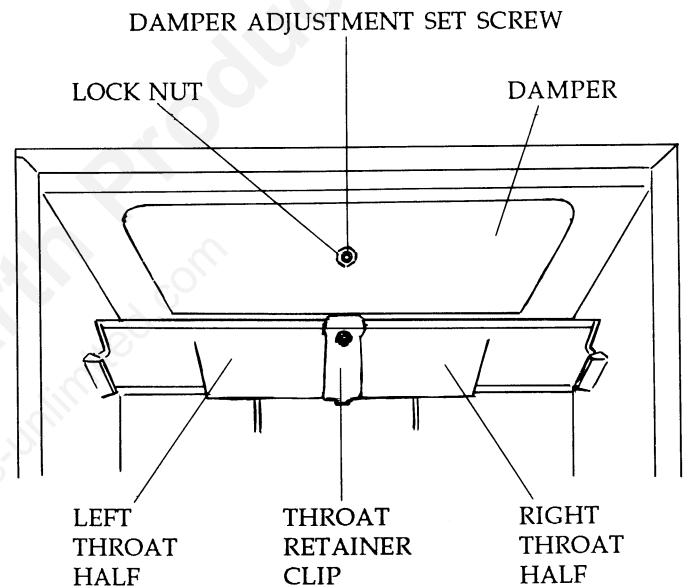

Coarse adjustment:

- Loosen the lock nut on the damper adjustment set screw as described for the fine adjustment, and turn the set screw counter-clockwise several full turns.

- Lift off the mantel piece to expose the damper latch.
 - With the damper open, loosen the latch retaining screw.
 - Move the latch approximately 1/8" (3 mm.) to the right, and retighten the retaining screw.
 - Close and lock the damper, and check for gap and rattle. Adjust the set screw as described above.
 - Repeat the coarse adjustment if necessary.
- If you need assistance, contact your local Vermont Castings Authorized Dealer.

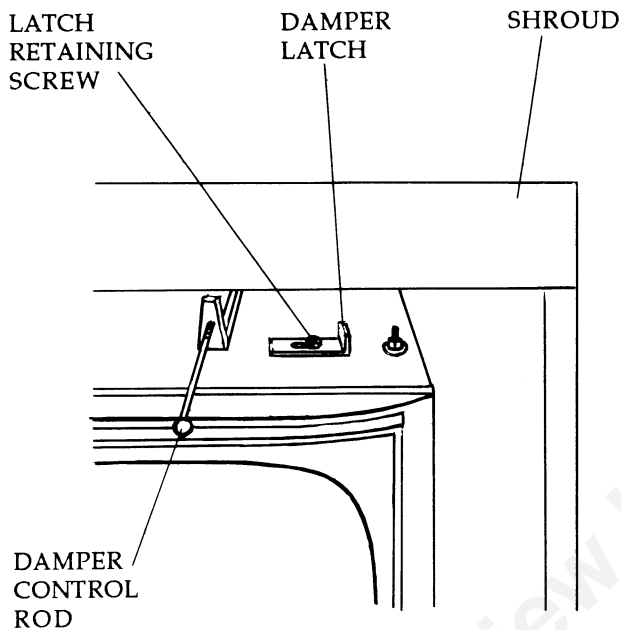

The Chimney System

CREOSOTE

When wood is burned slowly, it produces tar and other organic vapors, which combine with expelled moisture to form creosote. The creosote vapors condense in the relatively cool chimney flue of a slow-burning fire. As a result, creosote residue accumulates on the flue lining. When ignited this creosote makes an extremely hot fire.

The chimney connector and chimney should be inspected at least once every two months during the heating season to determine if a creosote buildup has occurred.

If creosote has accumulated it should be removed to reduce the risk of a chimney fire.

Although the catalytic system in your WinterWarm has been designed to significantly reduce creosote build-up, it is not a substitute for regular chimney inspection and maintenance. Until you are familiar with the build-up in your particular chimney, we suggest you inspect the system every two weeks.

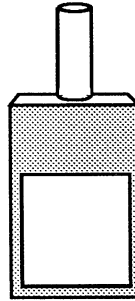

The prefabricated chimney used with the WinterWarm Fireplace System should be cleaned from above using an 8" round brush and the appropriate number of extension rods for complete access. Remove the chimney cap by turning it clockwise (chimneys such as Security ASHT, GSW Building Products, Metal-Fab Model TG); by unclamping the cinch band (chimneys such as Selkirk Metalbestos SS II); or by removing the two sheetmetal screws from the outer casing (chimneys such as Vitroliner HS Type HT). After thoroughly cleaning the chimney, reinstall the chimney cap according to the manufacturer's directions.

If you feel any uncertainties about chimney inspection or cleaning, contact your local Vermont Castings Authorized Dealer or engage a professional chimney sweep in your area.

The Firechamber

The WinterWarm firechamber should be thoroughly inspected for soot or creosote accumulation as part of your annual maintenance procedures. All interior parts should be removed and cleaned. Replacement parts are available from your Vermont Castings Authorized Dealer.

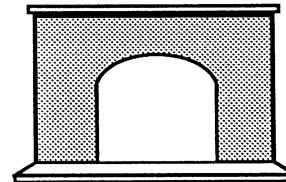

If you need to remove the WinterWarm firechamber from your fireplace to service the chimney, follow this procedure:

- Let the WinterWarm cool.
- Disconnect the fan power cord.
- Remove the load door, grate bar, grate and ash door.
- Retract all four levelling screws until they bear no weight.
- If you installed the Vermont Castings Flex Connector System, bend the four retaining tabs on the Starter Piece until they are straight. Push the Starter Piece upward until it is clear of the shroud.
- Slide the firechamber forward until you have access to the fireplace opening.
- Remove any sealing plates and the chimney connector from the fireplace damper frame area.

You may now inspect the smoke shelf area and the chimney. The chimney and smoke shelf area should be thoroughly brushed with a correctly sized chimney brush and inspected for signs of deterioration before replacing the WinterWarm.

Safety Tips

Do not overfire your WinterWarm. If a cast iron plate glows red you are overfiring. If overfiring occurs, adjust the primary air lever to decrease the air and slow the fire. If at any time it becomes difficult to slow or regulate the fire in a reasonable time, let the fire go out. Overfiring or difficulty in slowing the fire is the result of too much air entering the WinterWarm.

Check these points:

1. Is the gasketing in good shape so air does not leak into the firechamber around the door?
2. Is the door handle adjusted so the door closes tightly? Instructions for adjusting the handle are given in the Maintenance Section.



If draft in the chimney is interrupted, smoke, which contains carbon monoxide and other toxic gases, may be forced out of the WinterWarm into living areas. This is a potentially hazardous condition. If you notice an acrid smell or if smoke backs out of the WinterWarm frequently, let the fire go out. Be sure all air inlets are clear, the chimney connector and chimney are clean, and review the Operation section of this manual before starting another fire. The following suggestions may help solve draft related problems:

1. When your heating needs are light, in Spring and Fall for instance, and you are operating your WinterWarm to produce a small amount of heat, small, hot fires work well.
2. If you notice draft problems when the wind is blowing, consider installing a chimney cap designed to stabilize draft under windy conditions.



Keep all safety equipment ready for use.

1. Test the smoke alarm to be sure it is operating properly.
2. Be sure the fire extinguisher works and is clearly visible. All occupants of the house should know where it is, and how it operates.
3. Have heavy stove gloves available.
4. Have special safety accessories (for example, a Child Guard Screen) available for use if small children will be in the home.



In case of a chimney fire:

1. Close the damper and set the primary air lever at the lowest setting.
2. Get the people out of the house.
3. Call the Fire Department.

Glossary

FLUE: An opening which carries off smoke.

CHIMNEY: A masonry or prefabricated metal structure enclosing the flue.

CHIMNEY CONNECTOR: The sections of piping that connect an appliance to the flue of the chimney.

Chimney connectors are used only in the house, never as chimneys.

CHIMNEY FLUE LINER: The metal, fire clay or other approved lining in a chimney that protects the chimney walls from the hot gases in the flue.

CLEARANCE: The minimum safe distance between the appliance (or chimney connector) and nearby combustible surfaces. The clearance distance must be empty space except for non-combustible heat shields.

COMBUSTIBLE MATERIAL: Any material which will burn. A material is combustible if any part of it, either on the surface or in the interior, contains a combustible substance. Wood, wallpaper, paint, sheetrock, some veneer bricks, and plastic are all combustible materials.

NON-COMBUSTIBLE MATERIAL: Any material which will not burn when exposed to fire. Metal, brick, ceramic tile, concrete, stone, asbestos, and glass are all non-combustible. Floors, ceilings, and walls, including any unseen framework, must be constructed completely of such materials in order to be classified as non-combustible.

FLOOR PROTECTOR: A non-combustible pad placed in front of and to the sides of the WinterWarm, which protects the floor from sparks and falling embers.

HEARTH EXTENSION: A non-combustible pad placed in front of the WinterWarm, which protects the floor from heat radiating from the front of the fireplace.

CONVECTIVE HEAT: Heat transmitted by the movement of heated molecules. Warm air rising is a good example of natural heat convection. Convective heat transfer can be enhanced by the use of blowers.

RADIANT HEAT: Heat transmitted by infrared energy waves. The energy is converted to heat when the waves are absorbed by a solid surface, such as your body or a piece of furniture.

CREOSOTE: Combustible deposits of condensed smoke (vapors and tar mists). Creosote forms when flue gas temperatures are low, resulting in condensation of the smoky exhaust from incomplete combustion. A later hot fire can ignite the extremely flammable deposits and produce a potentially dangerous chimney fire.

DAMPER: A valve controlling the flow of air or smoke into the chimney.

FACTORY-BUILT FIREPLACE: A fireplace designed to be installed with a prefabricated, factory-built chimney. NOTE: NOT SUITABLE FOR USE WITH THE WINTERWARM.

MASONRY HEAT FORM: A factory-built metal form around which a code-approved masonry fireplace and a code-approved masonry chimney can be built. NOTE: SUITABLE FOR USE WITH THE WINTERWARM™ IF INSTALLED ACCORDING TO DIRECTIONS IN THE WINTERWARM™ FIREPLACE INSERT INSTALLATION MANUAL.

ZERO-CLEARANCE FIREPLACE: A term often used to describe a type of factory-built fireplace and chimney, with enough insulation and/or air space to allow installation directly next to combustible materials. A more accurate term is "reduced-clearance fireplace". NOTE: THE WINTERWARM™ IS A LISTED FIREPLACE PART FOR USE WITH THE VERMONT CASTINGS FIREPLACE CABINET, MODEL #1283. IN THIS APPROVED INSTALLATION, AND IN THIS INSTALLATION ONLY, THE WINTERWARM™ MAY BE USED IN A REDUCED-CLEARANCE SITUATION.

FIREPLACE CABINET (ALSO CALLED ENCLOSURE): The tested and listed component into which a tested and listed firechamber is inserted. The completed assembly is a reduced-clearance fireplace.

PRIMARY COMBUSTION CHAMBER: The main firechamber in which all primary combustion takes place. Partial secondary combustion will also occur.

PRIMARY COMBUSTION: The combustion of the solid portion of a fuel, for wood occurring at 450° F. to 500° F. (230 C to 260 C), but possible under certain conditions at temperatures as low as 200° F. (95 C).

VOLATILES: Various unburned hydrocarbons released as gases and vapors during the primary combustion of wood or coal. Volatiles can undergo further combustion, and may contain 50% or more of the heat potential of wood. When left unburned, volatiles represent a heat loss, and contribute to pollution.

CHARCOAL: Residue which remains after all the volatiles have been driven out of solid fuel. Primary combustion of charcoal continues until only inorganic ash remains. Primary combustion of true charcoal produces no flame.

SECONDARY COMBUSTION CHAMBER: A chamber in which combustion of volatiles takes place. The secondary chamber must be able to withstand the high temperatures of 1000° F. (540 C) or more generated by volatile combustion.

SECONDARY COMBUSTION: Combustion of the volatiles released during primary combustion, requiring temperatures in excess of 1000° F. (540 C) for ignition.

REFRACTORY: A solid material, often made of ceramic, capable of withstanding high temperatures in a corrosive environment.

APPENDIX - CATALYTIC COMBUSTORS

In any chemical reaction, including the combustion process, there are certain conditions which must be met before the reaction can take place. For example, a reaction may require a certain temperature, or a certain concentration of the reactants (the combustion gases and oxygen), or a certain amount of time. Catalysts, though not changed themselves during the reaction, have the ability to act at a molecular level to change these requirements. In the secondary combustion chamber of the WinterWarm, the catalyst reduces the temperature at which secondary combustion can occur from the 1000° F. - 1200° F. (540 C - 650 C) range to the 500° F. - 600° F. (260 C - 315 C) range, increasing efficiency, and reducing creosote and emissions.

The catalytic reaction, though advantageous, does have some limitations of its own. Primary among these is that the reactants (the gases) come into close physical contact with the catalyst itself. To ensure the necessary contact, the catalytic element in your WinterWarm is composed of a ceramic base in the shape of a honeycomb. On each of the honeycomb's many surfaces a coating of the catalyst (usually a noble metal such as platinum or palladium) is applied. The large surface area exposed in this configuration ensures that the combustion gases have the greatest opportunity to come in contact with the catalyst.

Loss of catalytic activity will be apparent in several ways. First you may notice an increase in fuel consumption. Second, there will be a visible increase in the rate at which creosote builds up in your chimney system. You may also notice a heavy discharge of smoke from the chimney. There are a number of catalytic problems which can cause loss of activity:

BLOCKAGE: While the honeycomb pattern ensures good contact, it also increases the resistance to flow of the combustion gases, and, because of the many surfaces, provides more places for creosote and fly ash to deposit. It is important to follow the operating instructions in order to minimize these deposits, and to periodically inspect your catalyst for signs of blockage.

MASKING OR POISONING: While the catalyst itself does not enter into the combustion process, it is possible for certain elements, such as lead and sulfur, to attach to the active sites on the surface of the honeycomb. Though the catalyst is still there, it is covered, or masked, by the contaminant, and cannot function. To avoid this situation, it is important not to burn anything in your WinterWarm which is a source of these contaminants. Particularly avoid painted or treated wood, coal, household trash, colored papers, metal foils, or plastics. Chemical chimney cleaners may also contain harmful elements. The safest approach is to burn only untreated, natural wood.

FLAME IMPINGEMENT: The catalytic element is not designed for exposure to direct flame. If you continually overfire your WinterWarm, the chemistry of the catalyst coating may be altered, inhibiting the combustion process. Thermal degradation of the ceramic base may also occur, causing the element to disintegrate. Stay within the recommended guidelines of the Operation section.

MECHANICAL DAMAGE: If the element is mishandled, damage may occur. Always treat the element carefully. Remember the catalyst is made of a ceramic material; treat it as you would fine china. Hairline cracks will not affect the performance of the catalyst, as long as the steel sleeve holds the element in the proper position.

PEELING: Peeling of the surface coat may occur if the catalytic element is frequently subjected to excessive temperatures. Follow the operating instructions carefully to avoid this type of damage.

Every Vermont Castings product is equipped with either a Corning Catalytic Combustor, or an element manufactured by Technical Glass Products. The products are equivalent. If for any reason you must ship your catalytic element, remember its fragile nature. Place the element in a plastic bag, and package it with a generous amount of shock absorbing material.

SAVE THIS INFORMATION FOR FUTURE REFERENCE

Please log all purchase information here. It will be helpful for servicing or warranty.

Model _____

Serial # _____

(Located on a metal tag permanently attached to the inside of the door of your Vermont Castings WinterWarm.)

Date of Manufacture _____

(Located on a metal tag permanently attached to the inside of the door of your Vermont Castings WinterWarm)

Where did you purchase your WinterWarm?

Date of Purchase _____

WARRANTY - FOR USE IN THE U.S.A. and CANADA LIMITED 3 YEAR WARRANTY

Vermont Castings, Inc. warrants that this WinterWarm™ Fireplace Insert or WinterWarm™ Fireplace System will be free of defects in material and workmanship for a period of three years from the date you receive it, except that the catalyst, thermostat assembly, handles, glass door panel, cement, and gasketing shall be warranted as described below.

Vermont Castings, Inc. will repair or replace, at its option, any part found to be defective when the WinterWarm™ Fireplace Insert or WinterWarm™ Fireplace System is returned with shipping charges prepaid to a Vermont Castings Authorized Dealer. The customer must pay for any Authorized Dealer in-home travel fees, service charges, or transportation costs for returning the stove to the Authorized Dealer. If upon inspection, the damage is found to be the fault of the manufacturer, repairs will be authorized at no charge to the customer for parts and/or labor.

Any WinterWarm™ Fireplace Insert or WinterWarm™ Fireplace System or part thereof that is repaired or replaced during the limited warranty period will be warranted under the terms of the limited warranty for a period not to exceed the remaining term of the original limited warranty or six (6) months, whichever is longer.

LIMITED 1 YEAR WARRANTY

The following parts of the WinterWarm™ Fireplace Insert or WinterWarm™ Fireplace System are warranted to be free of defects in material and workmanship for a period of one year from the date you receive it. These parts are the thermostat assembly, handles, glass door panel, cement, and gasketing. Any of these items found to be defective will be repaired or replaced at no charge, upon the return of said part to a Vermont Castings Authorized Dealer with postage prepaid.

Any part repaired or replaced during the limited warranty period will be warranted under the terms of the limited warranty for a period not to exceed the remaining term of the original limited warranty or six (6) months, whichever is longer.

LIMITED CATALYST WARRANTY

The catalyst will be warranted for a six year period as follows: If the original catalyst or a replacement catalyst proves defective or ceases to maintain 70% of its particulate emission reduction activity (as measured by an approved testing procedure) within 24 months from the date the WinterWarm™ is received, the catalyst itself will be replaced free. From 25 - 72 months a pro-rated credit will be allowed against a replacement catalyst and the cost of labor necessary for replacement at the time of replacement. The customer must pay for any in-home travel fees, service charges, or transportation costs for returning the WinterWarm™ to the Authorized Dealer.

AMOUNT OF TIME SINCE PURCHASE	CREDIT TOWARD REPLACEMENT COST
0 - 24 months	100%
25 - 36 months	50 %
37 - 48 months	30%
49 - 60 months	20%
61 - 72 months	10%

Any replacement catalyst will be warranted under the terms of the catalyst warranty for the remaining term of the original warranty. The purchaser must provide the following information in order to receive a replacement catalyst under the terms of this limited warranty:

1. Name, address and telephone number.
2. Proof of original purchase date.
3. Date of failure of catalyst.
4. Any relevant information or circumstances regarding determination of failure.
5. In addition, the owner must return the failed catalyst.

EXCLUSIONS & LIMITATIONS

1. This warranty is transferable; however, proof of original retail purchase is required.
2. This warranty does not cover misuse of the WinterWarm™. Misuse includes overfiring which will result if the WinterWarm™ is used in such a manner as to cause one or more of the plates to glow red. Overfiring can later be identified by warped plates and areas where the paint pigment has burned off. Overfiring in enamel fireplaces is identified by bubbling, cracking, chipping and discoloration of the porcelain enamel finish. Vermont Castings offers no warranty on chipping of enamel surfaces. Inspect your WinterWarm™ prior to accepting it for any damage to the enamel.
3. This warranty does not cover misuse of the WinterWarm™ Fireplace as described in the Owner's Guide, nor does it cover a WinterWarm™ which has been modified unless authorized by a Vermont Castings representative in writing. This warranty does not cover damage to the WinterWarm™ caused by a salt environment or from burning salt saturated wood, chemically treated wood, or any fuel not recommended in the Owner's Guide.
4. This warranty does not cover a WinterWarm™ repaired by someone other than a Vermont Castings Authorized Dealer.
5. Damage to the unit while in transit is not covered by this warranty but is subject to a claim against the common carrier. Contact the Vermont Castings Authorized Dealer from whom you purchased your WinterWarm™ or Vermont Castings if the purchase was direct. (Do not operate the WinterWarm™ as this may negate the ability to process the claim with the carrier.)
6. Claims are not valid where the installation does not conform to local building and fire codes or, in their absence, to the recommendations in our Owner's Guide.

HOW TO OBTAIN SERVICE

If a defect is noted within the warranty period, the customer should contact a Vermont Castings Authorized Dealer or Vermont Castings if the purchase was direct with the following information:

1. Name, address, and telephone number of the purchaser.
2. Date of purchase.
3. Serial number from the label on the inside of the load door.
4. Nature of the defect or damage.
5. Any relevant information or circumstances, e.g., installation, mode of operation when defect was noted.

A warranty claim will then start in process. Vermont Castings reserves the right to withhold final approval of a warranty claim pending a visual inspection of the defect by authorized representatives.



Vermont Castings, Inc.
Prince Street
Randolph, Vermont
U.S.A. 05060

Vermont Castings, Inc.
44 Friargate
Derby
Derbyshire DE1 1DA
England

November ©1988 Vermont Castings, Inc. All rights reserved. Parts and specifications subject to change without notice.

Printed in the U.S.A.

#200-0933

THE WINTER WARM™ FIREPLACE SYSTEM

— Large Winter Fireplace System Pre 01/91 —

by Vermont Castings

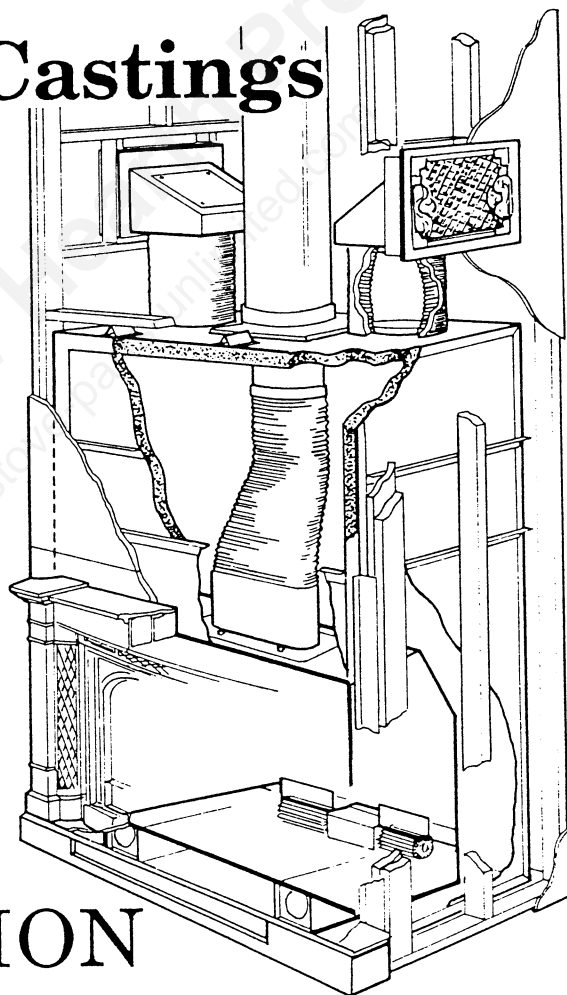

INSTALLATION MANUAL

For Use in the U.S.A. and CANADA

Cet guide d'utilisation est disponible en français chez votre concessionnaire de Vermont Castings.

WINTERWARM FIREPLACE SYSTEM SPECIFICATION CHART

Range of Heat Output*	10,300 - 30,000 BTU/hr.	Primary Air Control	Manually set, thermostatically maintained
Maximum Heat Output**	50,000 BTU/hr.	Secondary Air Control	Self-regulating
Area Heated***	up to 1500 sq. ft. (140 sq. m.)	Glass Panel	High-temperature ceramic, 5 mm. thick
Fuel Capacity	40 lbs. (18 kgs.)	Flue Exit Position	Top
Size & Type of Fuel	20"-24" (500 mm.-600 mm.) wood splits	Blower rating (each)	130 cfm. (115 V, 60 Hz)
Loading	Front	Minimum chase dimensions	Height 96" (2440 mm.)
Flue Size	8" (200 mm.) diameter	(See Installation Manual for details)	Depth 28.5" (725 mm.)
Weight	840 lbs. (380 kg.)		Width 39.5" (1000 mm.)

*Under specific test conditions used during EPA emissions standard testing.

**This value can vary depending on how the unit is operated, and the type and moisture content of the fuel used. Figure shown is based on maximum fuel consumption obtained under laboratory conditions and on average efficiencies.

***These values are based on operation in building-code conforming homes under typical winter climate conditions in New England. If your home is of non-standard construction (e.g., unusually well-insulated, not insulated, built underground, etc.) or if you live in a more severe or more temperate climate, these figures may not apply. Since so many variables affect performance, consult your Vermont Castings Authorized Dealer to determine realistic expectations for your home.

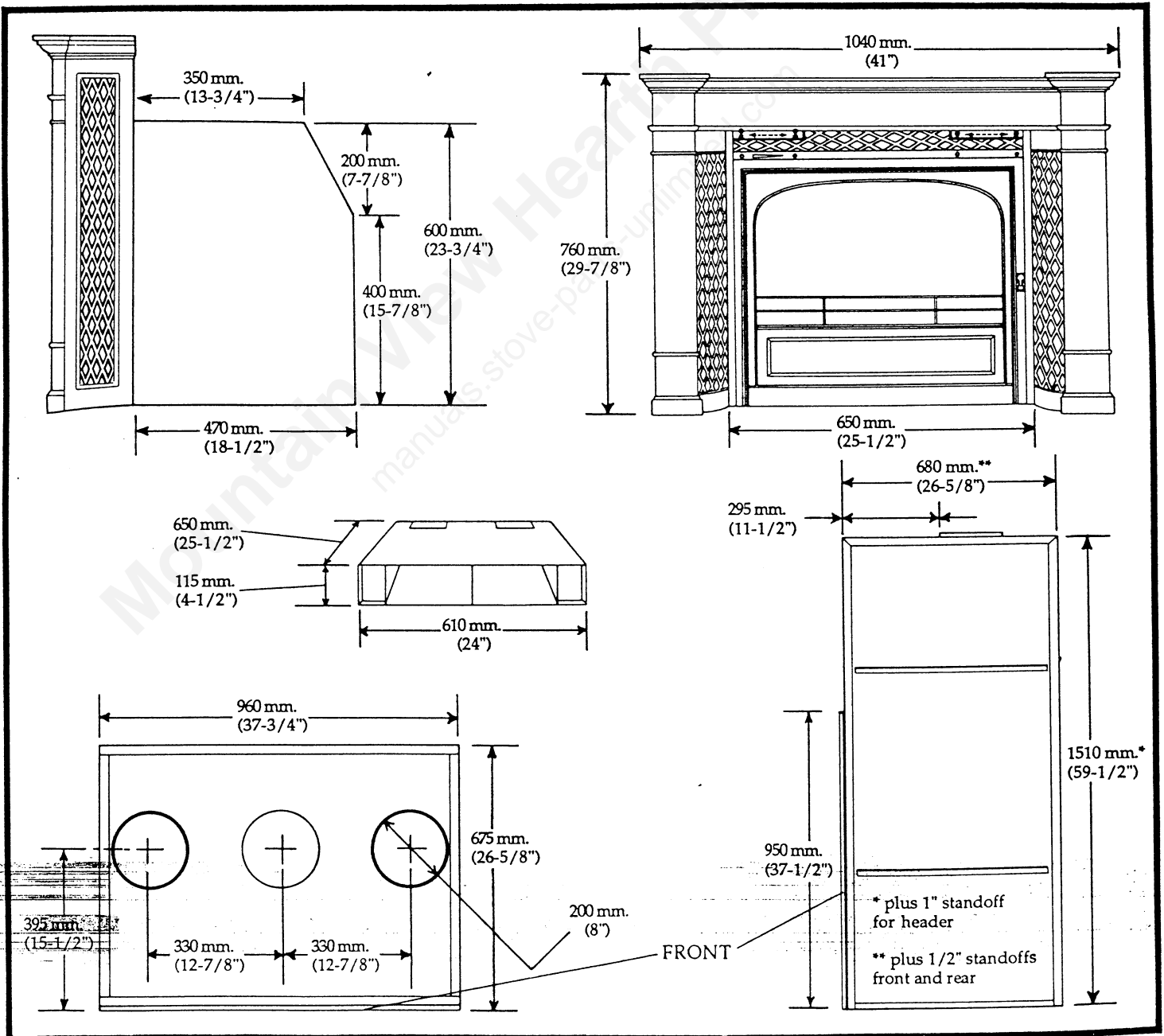

How to Use This Manual

This manual gives specific instructions for installation of the Vermont Castings WinterWarm™ Fireplace System as part of a complete prefabricated system including an approved prefabricated chimney. These instructions **DO NOT** apply to installation of the WinterWarm™ in a masonry fireplace. Instructions for the Fireplace Insert application will be found in a separate manual, packed with the WinterWarm firechamber.

If you do not have the correct manual, contact your local Vermont Castings Authorized Dealer or call 1-800-22-STOVE (1-800-227-8683), where an experienced Vermont Castings Team Fireside Advisor will assist you. (In Canada, call collect 1-802-728-3181, and ask for Team Fireside.)

Most of the information in this manual pertains to both U.S. and Canadian installations. In instances in which there are variations, flag symbols are used to denote the differences.

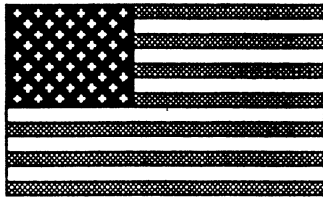

This symbol is used to highlight specific sections of the manual which apply only in the U.S.A.



This symbol is used to highlight specific sections of the manual which apply only in Canada.

Read these instructions through completely before beginning your installation. Time and effort spent on installing your WinterWarm Fireplace System properly will pay off handsomely in improved performance and safety.

Index

BASICS.....	2	INSTALLING THE CABINET.....	10
Tools		Electrical Considerations	
Options		Air Ducts	
CODES AND LISTINGS.....	2	The Grills	
SITE SELECTION.....	3	PREPARING THE WINTERWARM..	11
Chimney Selection		Outside Air	
THE HEARTH.....	4	The Front	
CONSTRUCTING THE CHASE.....	8	The Fans	
PREPARING THE CABINET.....	9	The Controls	
The Chimney Connector		The Mantel and Air Dividers	
The Spark Protector Strip		THE PLINTH.....	15
		GLOSSARY.....	16
		APPENDIX	17

SAFETY NOTICE: IF YOUR WINTERWARM FIREPLACE SYSTEM IS NOT PROPERLY INSTALLED, OPERATED AND MAINTAINED, A HOUSE FIRE MAY RESULT. FOR SAFETY, FOLLOW ALL INSTALLATION, OPERATION AND MAINTENANCE DIRECTIONS. CONTACT LOCAL BUILDING OFFICIALS ABOUT RESTRICTIONS AND INSTALLATION INSPECTION REQUIREMENTS IN YOUR AREA.

The WinterWarm™ Fireplace System has been tested by Underwriters' Laboratories of Canada, and is listed by Underwriters' Laboratories and Underwriters' Laboratories of Canada. The WinterWarm™ is listed for burning wood. Do not burn other fuels.

Basics

TOOLS AND SUPPLIES

The installation of the WinterWarm Fireplace System requires a good working knowledge of construction techniques as well as a wide selection of tools. If after reading these instructions you do not feel comfortable doing the installation yourself, contact your local Vermont Castings Authorized Dealer for assistance.

Tools required include:

- Safety glasses
- Heavy work gloves
- Drop cloth
- Brush and dust pan, or shop vac
- Drop light
- Measuring tape
- Level
- Wire brush
- Masking tape
- Utility knife
- Tin snips
- Chalk
- Straight edge
- Combination wrenches:
 - 5/16", 7/16", 1/2", & 9/16" sizes
- 1/4" ratchet handle, with 6" extension
- 1/4" sockets:
 - 1/4", 5/16", 7/16", & 1/2" sizes
- Phillips screwdrivers, medium & small tips
- Slot head screwdriver
- Slip joint pliers
- Rubber mallet

The WinterWarm Fireplace System is shipped in four (U.S.) or five (Canada) boxes. The first contains the firechamber and assorted components necessary for its installation. The second box contains the decorative front, in flat black or one of the available porcelain enamel finishes, and includes the columns, the mantel, the rheostat control, the junction boxes, and the side latticed panels. All hardware necessary for assembly is included.

The third box consists of the enclosure, or cabinet, and the components needed for installation of the firechamber within the enclosure. The fourth box contains the decorative end caps used to finish the trim of the WinterWarm plinth. In addition, Canadian WinterWarm Systems include a required hearth extension pad. Detailed instructions for its use are given in the Hearth section of this manual.

OPTIONS

The following options are available for your WinterWarm Fireplace System:

- Decorative Surround Panels
- Outside Air Kit
- Cabinet Convection Fan

If you have chosen any of these options, look over the instructions that come with each kit, and make sure you have all necessary materials at hand before beginning your installation.

Codes and Listings

Conforming to local building codes will be an important part of your planning. Local authorities make the final decision on whether or not an installation will be approved. They need to know that your installation is safe and meets local and state codes.

A metal label permanently attached to every Vermont Castings stove or fireplace indicates that it has been tested to current UL or ULC standards, and gives the name of the testing laboratory. In most cases, local authorities will accept the label as evidence that, when the WinterWarm Fireplace System is installed according to the information in this manual, the installation meets codes and can be approved.

However, codes vary in different areas. Be sure to review your installation plans with your local authority before starting the installation. Check with your local Vermont Castings Authorized Dealer for help in providing the necessary information to local officials.

Information given in this manual will answer clearance and construction questions for almost all installations. For questions left unanswered, we recommend that you refer to the National Fire Protection Association ANSI/NFPA 211-1988 Standard for Chimneys, Fireplaces, Vents and Solid Fuel Burning Appliances, or, in Canada, CSA B365. These standards are the basis for many national and local codes, and are accepted by many local authorities. Your local Vermont Castings Authorized Dealer, or your local building official may have a copy.

Remember, your local building official makes the final decision on approval of installations.

Read these instructions carefully before proceeding with the installation of your Vermont Castings WinterWarm Fireplace System. Failure to do so may result in personal injury or damage to the appliance which may void the warranty.

Site Selection

The WinterWarm Fireplace System installs in an opening just 96" (2440 mm.) high, 28-1/2" (725 mm.) deep, and 39-1/2" (1000 mm.) wide (exclusive of the chimney), allowing the enjoyment of a beautiful and efficient fireplace in far less room and at less cost than that necessary for installation of a masonry fireplace and chimney.

Before selecting the location for the WinterWarm Fireplace System, take some time to think over what position will best suit your needs. The powerful heating capacity of the WinterWarm will be utilized to the fullest if the installation is centrally located. Air duct placement (front or side), which determines how the heated convection air will be distributed, should be carefully planned for maximum comfort.

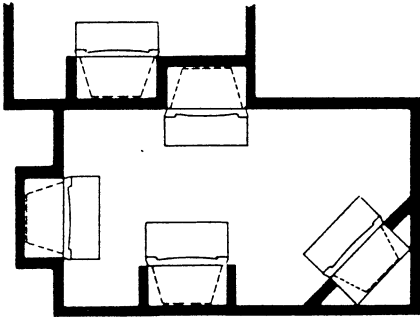

Chimney placement should be planned to minimize offsets and structural modifications. An inside chimney tends to stay warmer and provide a more stable and reliable draft. An outside chimney, properly installed, should be satisfactory, though an insulated chase may be necessary to maintain adequate flue gas temperatures.

If you are planning an installation using the Outside Air option, be sure your WinterWarm's positioning allows access to the outside within 20 feet. Outside air ducts should contain as few elbows or offsets as possible.

CHIMNEY SELECTION



The WinterWarm Fireplace System is listed for use with any 8" prefabricated chimney tested and listed to the high temperature (650 C) chimney standard, ULC S-629.

**DO NOT USE ANY OTHER
CHIMNEY SYSTEM WITH THE
WINTERWARM FIREPLACE
SYSTEM.**

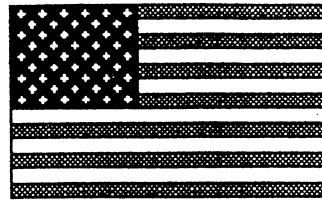

The WinterWarm Fireplace System is listed for use with five chimney systems which have been tested and listed to the High-Temperature (H.T.) Chimney Standard UL-103-1985 (2100° F.). The listed chimneys are:

Security ASHT
Selkirk Metalbestos SS II
GSW Building Products (Jacks-Evans) Model SC
Metal-Fab Model TG
Vitroliner HS type HT

**DO NOT USE ANY OTHER
CHIMNEY SYSTEM WITH THE
WINTERWARM FIREPLACE
SYSTEM.**

All chimneys must be 8" inner diameter. The chimney must be installed EXACTLY as outlined in the chimney manufacturer's installation instructions.

The chimney system components required will be determined by your installation. Your Vermont Castings Authorized Dealer can advise you on which system will be best for your needs. The following requirements must be met by all chimney systems used with the WinterWarm Fireplace System:

1 - The chimney must be supported from either the roof or the floor joists. The cabinet itself is not intended to be the sole support of the chimney. Support systems are available from the chimney manufacturer.

2 - The chimney used with the WinterWarm must be firmly connected to the top of the WinterWarm cabinet using an anchor plate provided by the chimney manufacturer specifically for this use.

3 - Firestops must be used where the chimney passes through a combustible ceiling. Use the firestop designed for use with the specific chimney selected. Do not use firestops from any other source.

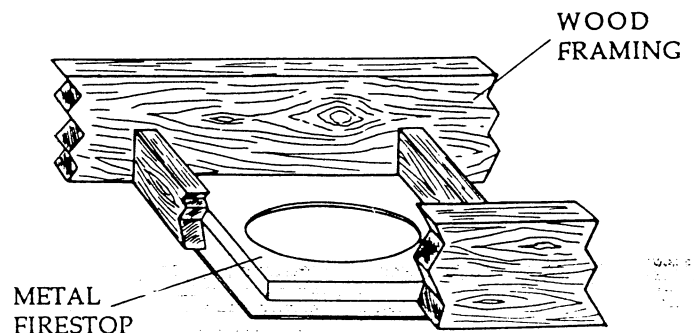

4 - A chimney cap is required at the termination of the chimney. Use the cap designed for use with the specific chimney selected for your installation.

5 - The installation may include a maximum of four 30° offsets (provided the listed chimney system chosen offers such offsets). The first offset must occur eight or more feet above the finished floor.

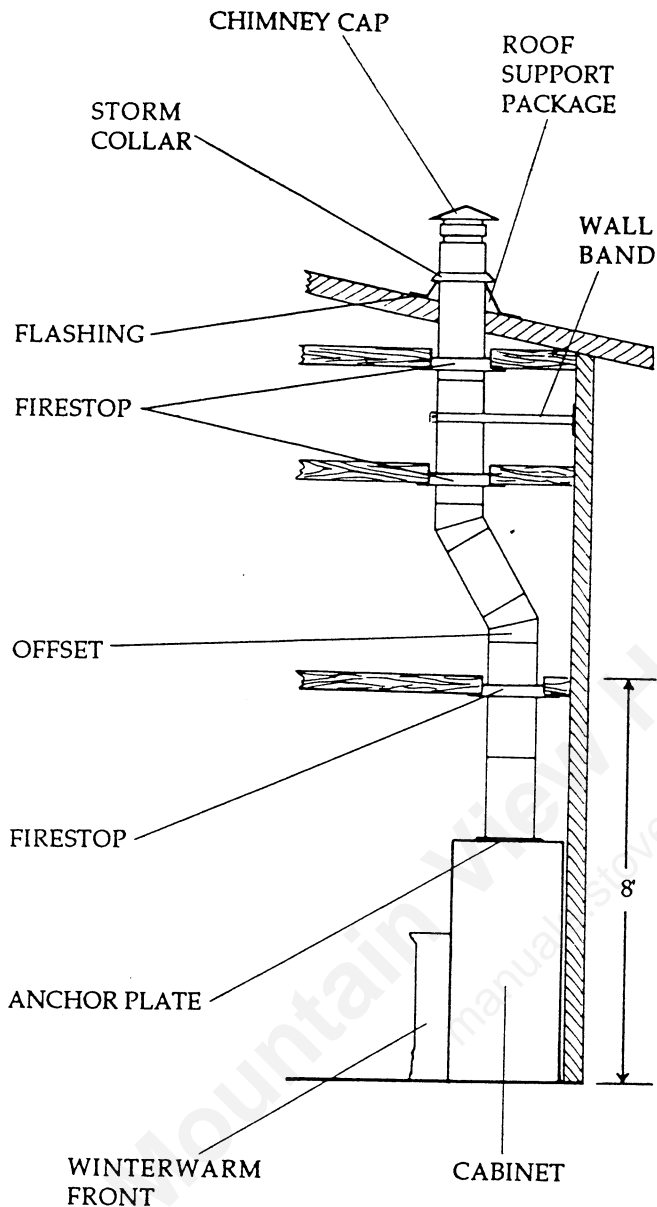

6 - Special components (e. g., joist shields) must be used if called for in the chimney manufacturer's instructions. Follow the manufacturer's instructions EXACTLY when installing your chimney.

7 - The chimney should extend at least 3 feet (90 cm.) above the highest point where it passes through a roof, and at least 2 feet (60 cm.) higher than any portion of a building within 10 feet (305 cm.).

8 - Vermont Castings recommends that for proper draft and good performance, any chimney used with the WinterWarm Fireplace System extend at least 15 feet (4.6 m.) above the hearth surface. The maximum length of chimney used with the WinterWarm Fireplace System is 35 feet (10.7 m.) above the hearth.

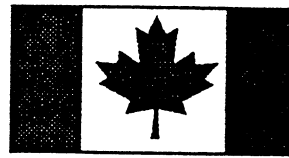

The Hearth

Unless your WinterWarm Fireplace System is installed on unpainted concrete over dirt, both a floor protector and a hearth extension must be used.

A floor protector is required to protect from spilled coals and embers. This may be any non-combustible material, without open joints or seams, and should measure 1020 mm. (40") wide and extend from the front of the cabinet to a point 450 mm. (18") in front of the load door. If sheetmetal is used, it should be a minimum of 0.38 mm. thick.

A hearth extension is shipped with your WinterWarm, and must be used to complete the installation. The hearth extension protects the area directly in front of the door from heat which radiates from the front of the WinterWarm. The hearth extension is 600 mm. (24") wide, and 480 mm. (19") deep, and must be placed butted up to the indented front of the plinth upon completion of the installation.

Extending the front of the floor protector to match that of the installed hearth extension will give your WinterWarm an attractive, finished look.

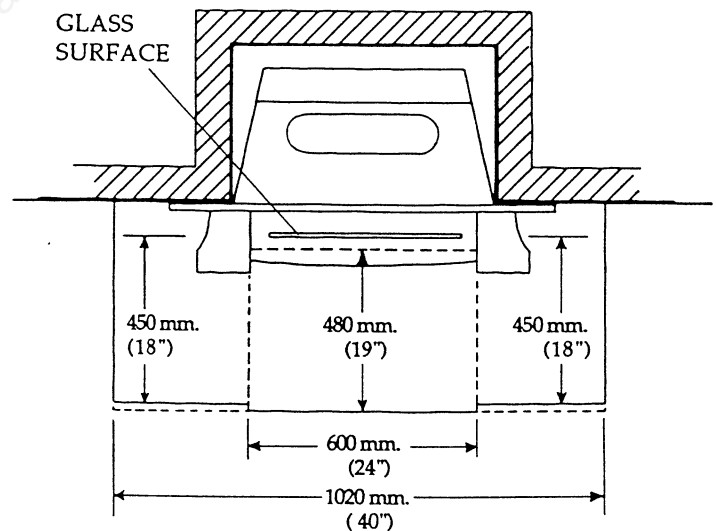

In addition to the floor protector and the hearth extension, an 80 mm. (3") by 960 mm. (38") strip of sheetmetal (included in your Fireplace System) must be laid underneath the joint between the front of the cabinet and the ventilated plinth as an additional spark protector. Instructions for its installation are given later in the manual.

The following illustrations and descriptions detail two types of floor protector and hearth extension construction suitable for use with the WinterWarm Fireplace System.

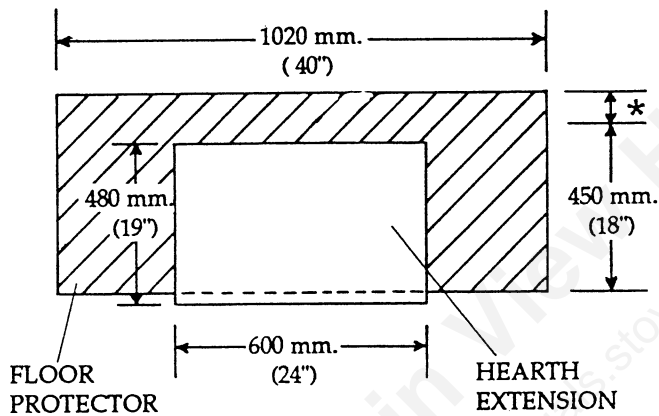
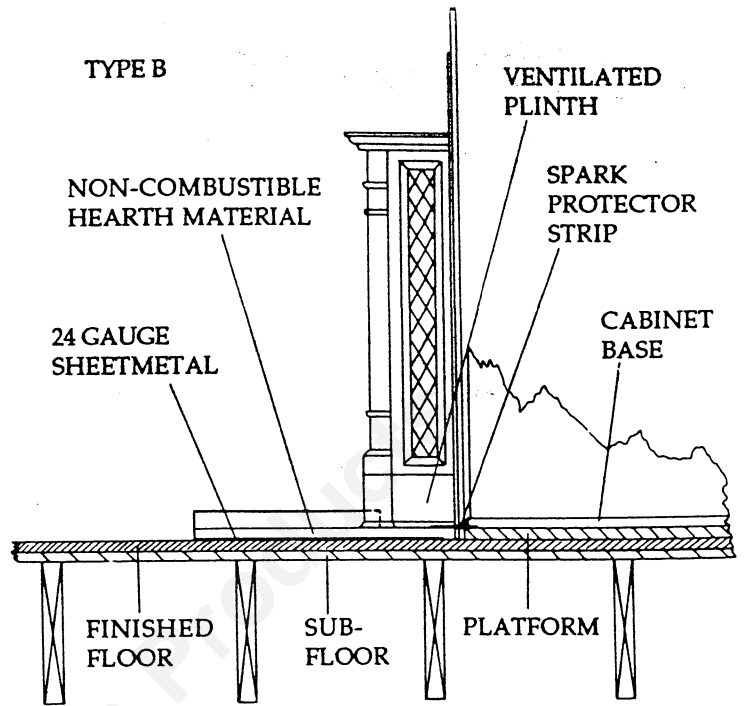
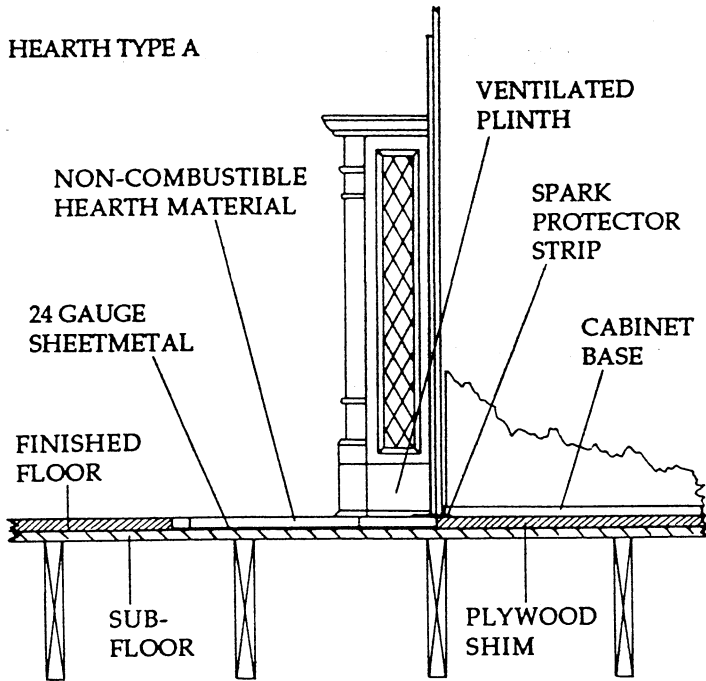

WARNING: THE AIR INLET THROUGH THE VENTILATED PLINTH MUST NOT BE BLOCKED.

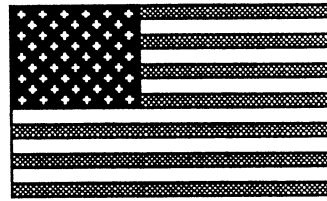

The Hearth

* THIS DISTANCE WILL VARY SLIGHTLY DEPENDING ON THE MATERIAL CHOSEN FOR FINISHED WALL AND SURROUND.

In type A construction, the WinterWarm cabinet rests on a surface which is level with the finished floor. The floor protector and the hearth protector are both inlaid flush with the floor. (The hearth extension is actually inlaid into the floor protector.) The seams between the floor protector and hearth extension must be mortared, or a piece of sheetmetal extended under the entire assembly. The spark protector strip extends under both the plinth and the cabinet.

In installation type B, the floor protector is laid over the finished floor, and the hearth extension is placed on top of the floor protector once the installation of the cabinet is complete. **NOTE:** In order to retain the proper fit between the WinterWarm front and the plinth, the cabinet must be elevated by an amount equal to the thickness of the floor protector. If you raise the cabinet more than 1" (25 mm.), a corresponding increase in the height of the framed chase is required to retain adequate clearances.

The spark protector strip extends under both the plinth and the cabinet.

Unless your WinterWarm Fireplace System is installed on unpainted concrete over dirt, both a floor protector and hearth extension must be used.

A floor protector is required to protect from spilled coals and embers. This may be any non-combustible material, without open joints or seams, and should measure 40" wide and extend from the front of the cabinet to a point 16" in front of the load door. If sheetmetal is used, it should be a minimum 24 gauge.

A hearth extension must be in place to complete the installation. The hearth extension protects the area directly in front of the door from heat which radiates from the front of the WinterWarm. During testing, the required WinterWarm hearth extension was determined to consist of a layer of 24 gauge sheetmetal covered by a 7/16" layer of WonderBoard (a commonly available mineral board), and measuring 24" wide by 19" deep as measured from the front indentation of the installed plinth. For ease of installation, we recommend combining the floor protector and hearth extension into one unit, using the required sheetmetal/mineral board construction throughout. Examples of various hearth construction possibilities are given later in this section.

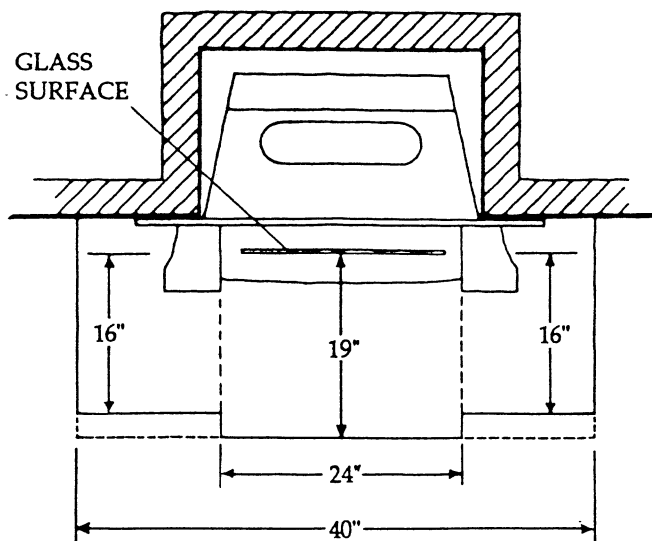

A hearth may be custom made if care is taken to ensure that it offers protection equivalent to the tested standard. To determine equivalency, you must first determine the thermal conductivity of the material. Thermal conductivity, or "K", is a measure of how quickly heat will pass through a given material to combustible material underneath, and is described in the rather technical units of (BTU)(IN)/(FT²)(HR)(F°). Fortunately, this can be represented more simply as a number — for the WinterWarm's tested standard the K value is 0.84. Custom built extensions must have a K value equal to or less than 0.84, indicating that heat transfer occurs at the same speed or more slowly than the standard tested hearth extension.

You may also choose a tested and listed hearth extension of K value 0.84 or less. Your local Vermont Castings Authorized Dealer can help you assess the hearth extension possibilities for your Fireplace System.

In addition to the hearth itself, a 3" by 38" strip of sheetmetal (included in your Fireplace System) must be laid underneath the joint between the front of the cabinet and the ventilated plinth as a spark protector. Instructions for its installation are given later in the

manual.

NOTE: When the plinth is elevated on a floor protector, the cabinet must be elevated by the same amount in order to retain the proper fit between the WinterWarm front and the plinth. If you raise the cabinet more than 1" (25 mm.), a corresponding increase in the height of the framed chase is required to retain adequate clearances. It is necessary, therefore, to decide on your hearth style before beginning chase construction. The design you choose will determine the final dimensions of the framed chase housing the WinterWarm Fireplace System cabinet and air ducts.

SUGGESTED HEARTH CONSTRUCTIONS

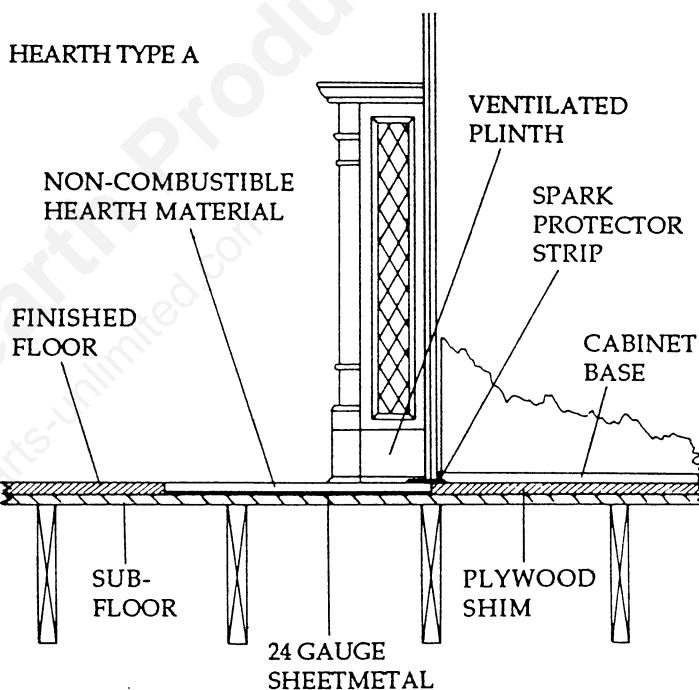

In this type of hearth construction the WinterWarm cabinet rests on a surface which is level with the finished floor. The combined floor protector/hearth extension is inlaid so that it too is level with the finished floor. The spark protector strip extends under both the plinth and the cabinet.

CALCULATION FOR THICKNESS OF AN ALTERNATE HEARTH EXTENSION MATERIAL

To calculate the thickness of an alternate material necessary to provide the required protection, obtain its K factor (available from your building supply house) and then use the following formula:

$$\frac{(\text{K factor of alternate material}) \times (\text{Thickness of WonderBoard required})}{(\text{K factor of WonderBoard})} = \text{Required thickness of alternate material}$$

OR

$$\frac{(\text{K factor of alternate material}) \times (7/16")}{(0.84)} = \text{Required thickness of alternate material}$$

A commonly used material, brick, provides an example. The K factor for brick is 5.0.

$$\frac{5.0 \times (7/16")}{0.84} = 2.6"$$

That is, when using brick for the hearth extension, the brick must be a minimum of 2.6" thick. Similar calculations may be performed for any noncombustible material provided its K factor is available. If you have questions about hearth extensions, contact your local Vermont Castings Authorized Dealer.

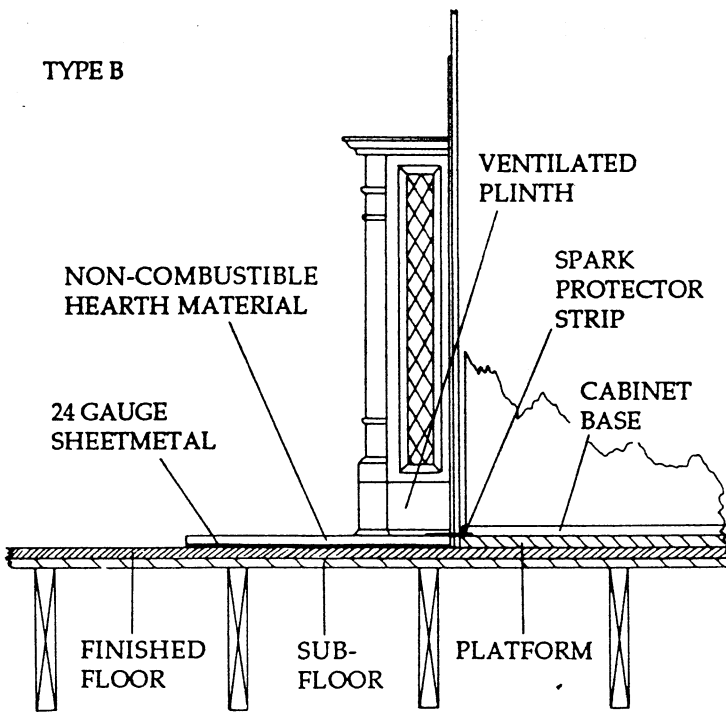

In this type of construction, the combined floor protector/hearth extension is placed over the finished floor. It extends completely under the ventilated plinth.

The cabinet is elevated by the same amount, resulting in placement of both the plinth and cabinet at the same level. **IMPORTANT:** Elevating the cabinet more than 1" requires a corresponding increase in the height of the framed chase to retain adequate clearances.

The spark protector strip extends under both the plinth and the cabinet.

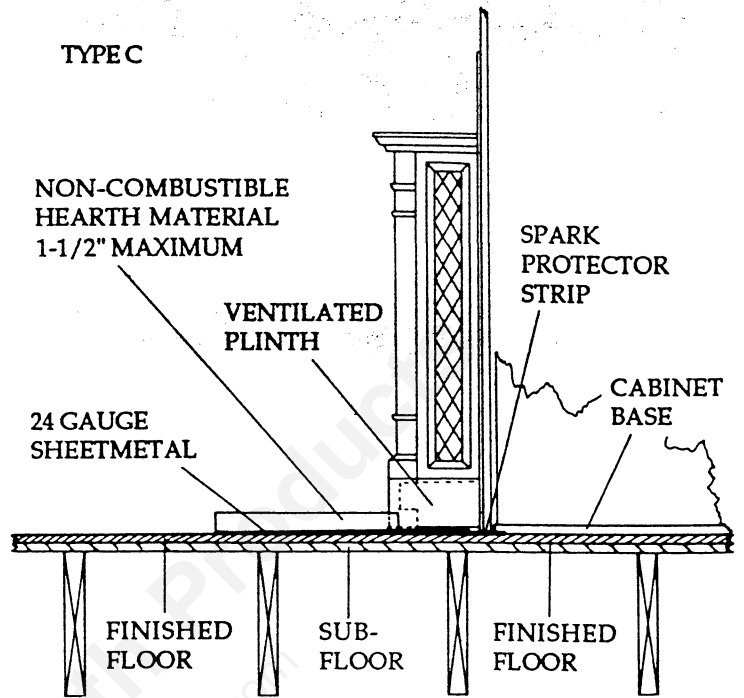

In this type of construction, the floor protector/hearth extension is raised above the finished floor level, but rather than extend completely under the plinth, the surface covering (WonderBoard or equivalent material) merely abuts it. The 24 gauge sheetmetal base extends all the way under the plinth to the cabinet front. The cabinet is at finished floor level. **NOTE:** The total thickness of the floor protector/hearth extension may not exceed 1-1/2", in order to avoid interfering with the flow of air through the ventilated plinth.

The spark protector strip underlies the cabinet and the plinth.

WARNING: THE AIR INLET THROUGH THE VENTILATED PLINTH MUST NOT BE BLOCKED.

Constructing the Chase

Frame the cabinet and air duct chase in accordance with your desire for air duct location. The openings for the air ducts must be a minimum of 12" (300 mm.) below the ceiling, and may be located either to the side of the WinterWarm chase, or to the front. If desired, one duct may be located on a side, and one on the front. The ducts may be extended with class 0-1 insulated duct material, as long as the vents are in the same room as the WinterWarm and are 12" below the ceiling as required.

The accompanying diagrams are for suggested chase constructions using the minimum allowed dimensions:

Height: 96" (2440 mm.)
 Depth: 28-1/2" (725 mm.)
 Width: 39-1/2" (1000 mm.)

SUGGESTED FRONT FRAMING

FRONT VENTS

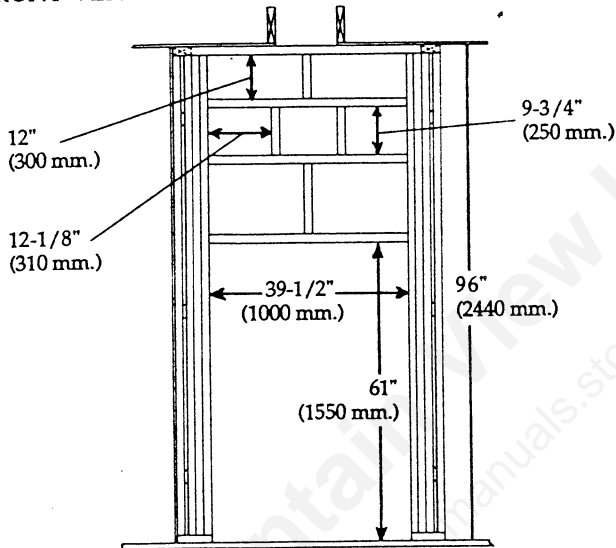

SIDE VENTS

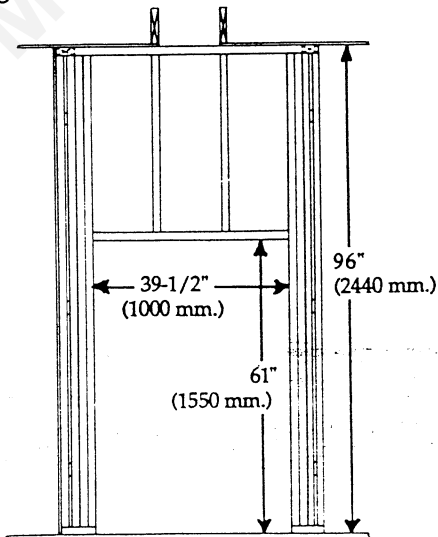

SUGGESTED FRAMINGS

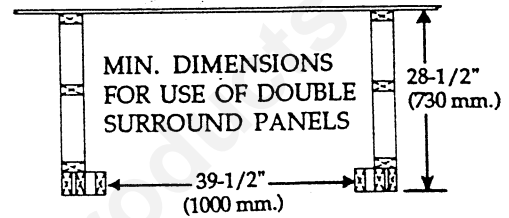
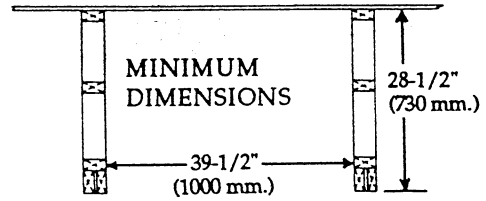

SUGGESTED SIDE FRAMINGS

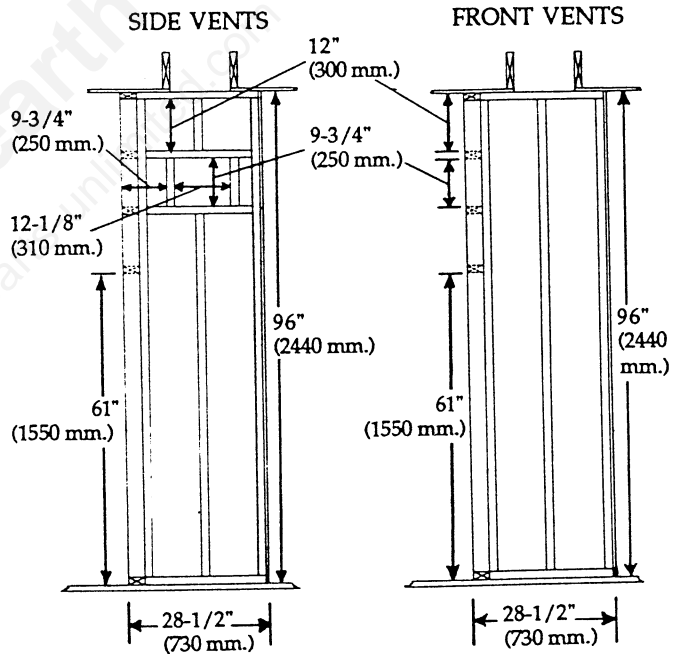

SUGGESTED FRAMING - CORNER INSTALLATION

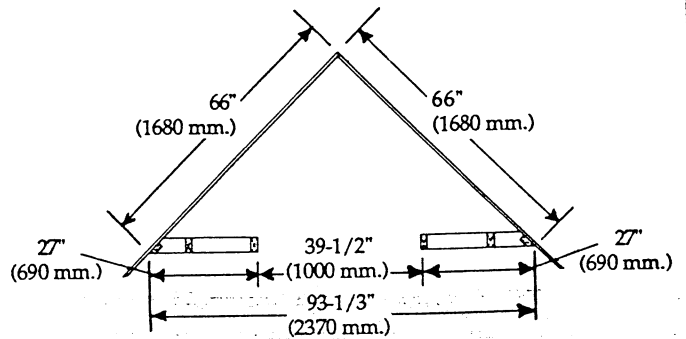

IMPORTANT: A cabinet raised over 1" as a result of a raised hearth must have a correspondingly higher chase in order to retain adequate clearances. Details are given in the Hearth section of the manual.

ELECTRICAL REQUIREMENTS

Install a 115 V. 15 or 20 AMP. electric service line to the bottom front corner of the left side chase framing (2 wire plus ground).

If installing the optional Cabinet Convection Fan Kit, locate the site where you want your fan speed control switch and mount a standard single switch box to the chase framing.

Run a length of 2 wire cable from this box down to the service line. Leave enough slack so that this cable and the service cable will enter the junction box in the cabinet when installed. Refer to the instructions which are shipped with the optional Cabinet Convection Fan Kit.

OUTSIDE AIR

An outside air duct should be no longer than 20 feet (600 cm.) with a maximum of three elbows, and should terminate at an outside air source. Do not terminate the duct in a garage, attic, basement, or near another fuel-fed appliance. The outside air inlet must not be higher than the air entry port into the WinterWarm shroud.

Refer to the instructions which are packed with the Outside Air Kit for detailed instructions.

PREPARING THE CABINET

The three cabinet trim pieces, which act as dry wall stops, must be installed. Stand the cabinet in the upright position. Remove the two hex head self-drilling and tapping sheetmetal screws which are installed just outside the cabinet opening, one at each upper corner. Align each side trim piece so that the pilot holes drilled in the trim piece match the holes drilled in the cabinet. Reinsert the two corner screws, using a 5/16" socket, and insert additional hex head sheetmetal screws at each drilled hole.

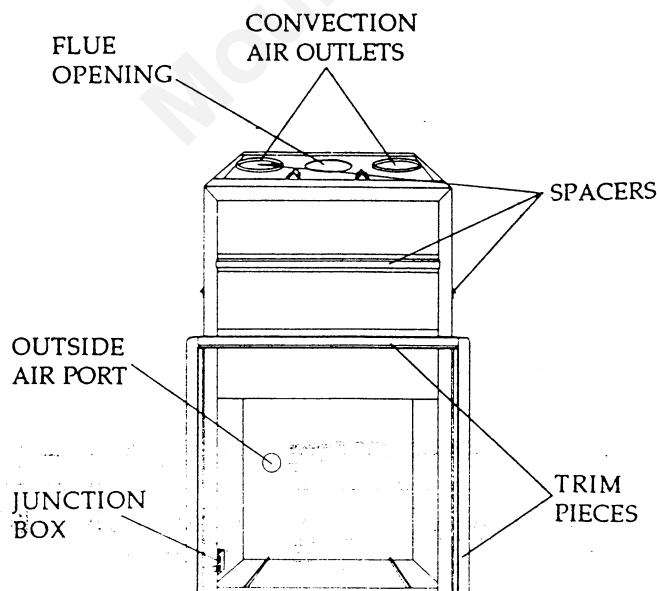

Before the top trim piece (dry wall stop) can be permanently attached it must be properly aligned and its pilot holes used to drill the attachment holes into the cabinet. To align the trim piece, center it on top of the two installed side pieces. The edge with screw holes should be towards the top and contacting the cabinet front; the protruding flange should meet the comparable flanges on the side trim pieces. Using a fine felt tip pen, mark the cabinet through each pilot hole. Using a 5/32" drill bit, drill through the outer cabinet wall. Install the trim piece with the remaining sheetmetal screws. (Alternate procedure: using the pilot holes in the dry wall stop as guides, install the self-drilling and tapping hex head sheetmetal screws with an electric drill and a 5/16" hex head driver.)

CHIMNEY CONNECTOR

Install the chimney connector and attached flue flange to the underside of the cabinet top, using eight #10-1/2" self-drilling and tapping hex head sheetmetal screws. The connector should point forward as shown in the accompanying illustration, with the long axis of the oval running from side to side.

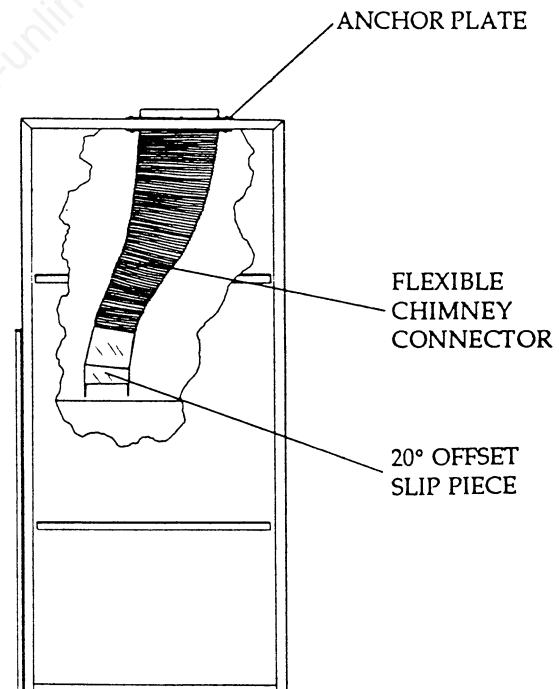

Install the offset slip piece by sliding it up over the bottom of the chimney connector, with the four tabs pointing down.

CHIMNEY ANCHOR PLATE

Fit the chimney system anchor plate appropriate to your chosen prefabricated chimney over the flue outlet at the top of the cabinet and mark the attaching hole

centers; remove the anchor plate and drill the fastener holes. Do not install the plate at this time.

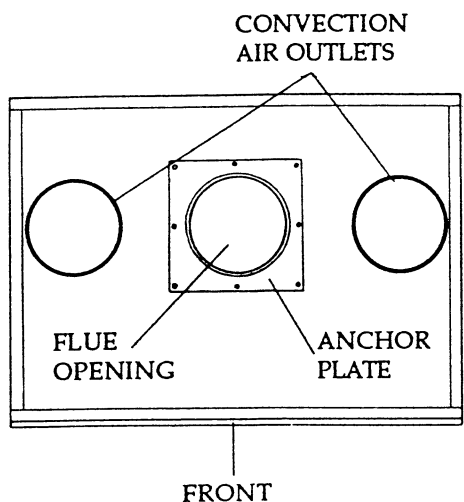

SPARK PROTECTOR STRIP

To install the 3" x 38" (80 mm. x 965 mm.) spark protector strip, first draw a line on the hearth parallel and 2" (50 mm.) in front of the chase opening. Center the spark protector strip in the chase opening, with the outside edge on the line. Nail or screw the strip down so that the fastener heads are flush with the spark protector strip's surface.

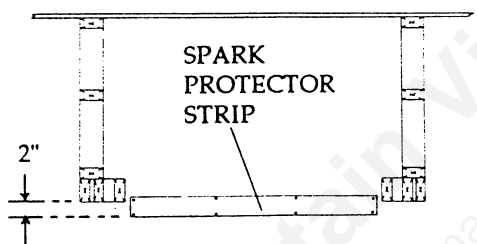

INSTALLING THE CABINET

Push the cabinet carefully into the chase opening until the dry wall stop flanges contact the vertical studs. **IMPORTANT:** If the cabinet does not slide easily into position, **DO NOT** force it. Forcing the cabinet may damage the stand-offs which ensure adequate clearance from combustibles. Double-check your framed chase dimensions to make sure you have allowed enough clearance before proceeding.

WARNING: DO NOT PACK REQUIRED AIR SPACES WITH INSULATION OR OTHER MATERIALS.

Place a horizontal straight edge across the vertical front studs; the dry wall standoff on the front of the cabinet should just touch the straight edge.

After the cabinet has been installed to its proper depth, double-check all stand-offs for proper clearance. Screw the cabinet to the floor through the 8 drilled

holes, using the 8 #10 Phillips pan head sheetmetal screws provided.

Fasten the top corners of the trim pieces (dry wall stops) to the flanking studs with dry wall screws.

Remove the cover plate from the junction box in the cabinet. Pull the electric service cable (and the switch cable if installing the optional Cabinet Convection Fan Kit) into the cabinet junction box and wire the junction box as shown in the accompanying illustration. (NOTE: The illustration shows the required wiring for an installation using the optional Cabinet Convection Fan Kit. If the installation does not use the optional fan, **ONLY** the upper receptacle is live.) Secure and tighten strain relief.

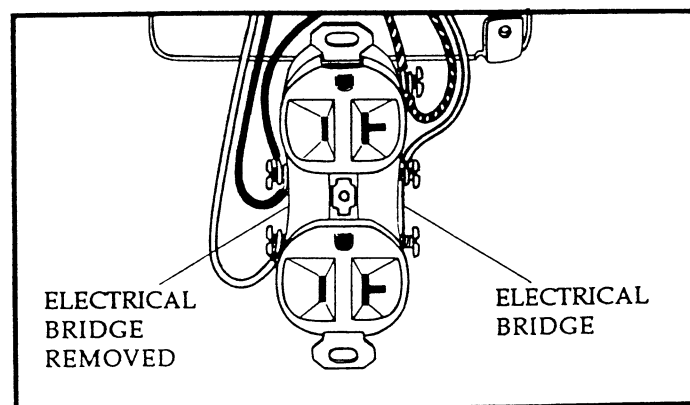
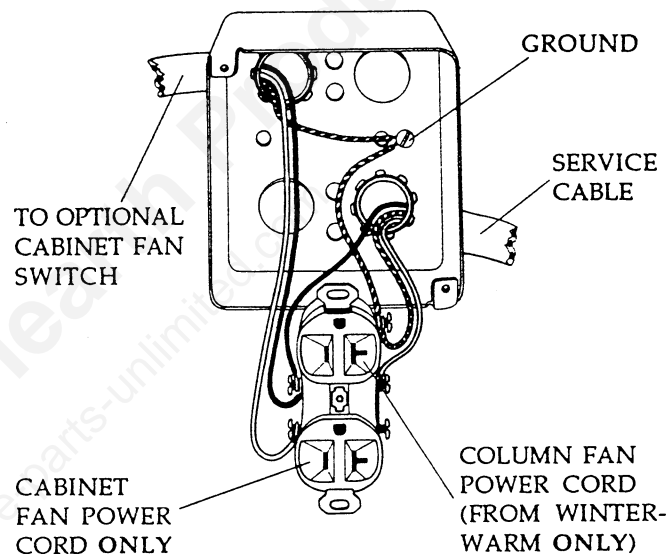

Install the required chimney anchor plate to the top of the cabinet. Use a 1/8" (4 mm.) bead of gasket cement to seal the flange to the cabinet. Install the chimney according to the manufacturer's instructions; follow the instructions exactly.

AIR DUCTS

Before installing the air duct boxes, you may wish to paint the inner surfaces with Vermont Castings High-Temperature Stove Paint (or other high-temperature paint) to reduce the glare from reflected light.

Install the two air duct boxes in their framed openings. Position the angled side down if using front ducts or a wide chase (over 48" [1200 mm.] outside dimension). Position the flat side down if using side venting and a narrow chase (less than 48" [1200 mm.] outside dimension).

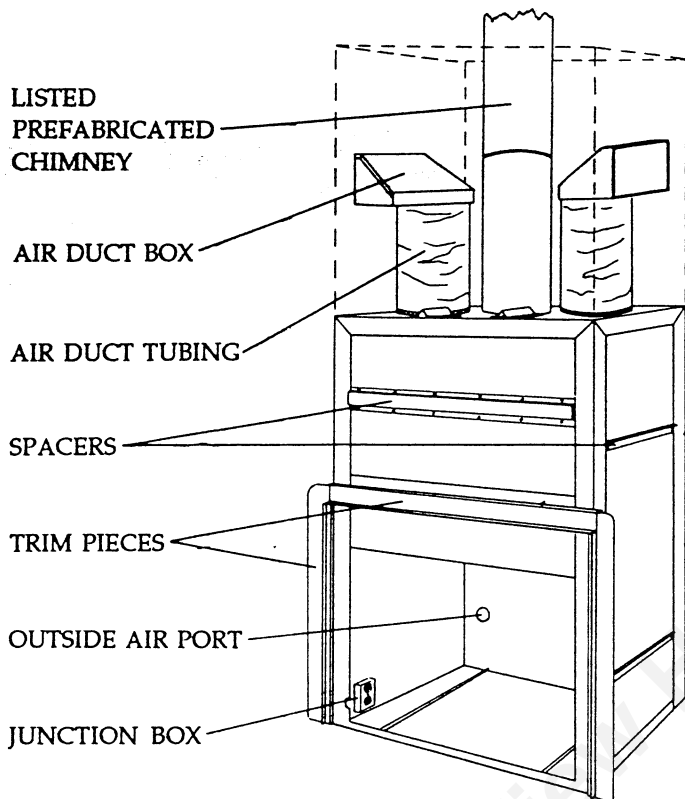

If desired, paint the inner surface of each air duct tube for about 6" (155 mm.) to eliminate reflected glare; attach this end to the air duct box flange. Cut and fit the air duct tubing between the air duct boxes and the top of the cabinet. Cut the tubing a few inches too long — it can be compressed during installation. To cut the tubing to size, use a serrated edge kitchen knife. The duct tubing must fit onto both the duct box and the cabinet flanges the full length of the flanges (1" [25 mm.]) all the way around. Secure each end of the tubing to the appropriate flange with one of the four clamps provided.

FAN KIT

If you have chosen the optional Cabinet Convection Fan Kit, install it using the instructions provided with the Kit. Slide the base into the cabinet and plug the fan cord set into the bottom electrical receptacle in the cabinet junction box.

FINISHING THE CHASE

Cover the outside walls of the chase with the wall covering material of your selection. When fastening the wall covering to the metal standoff and dry wall stops at the cabinet we recommend using dry wall screws. Drill pilot holes through your wall covering material and one thickness of the sheetmetal with a #40 (.098")

drill bit.

Tape and fill holes and/or seams and decorate your chase walls at this time.

INSTALLING THE VENT GRILLES

Position the cast grilles over the duct box openings, and mark for the four screw holes in each. Using a 5/32" bit, drill through the dry wall and duct box flanges, and install the grilles with the slot head black oxide screws.

PREPARING THE WINTERWARM

Uncrate the WinterWarm and place it mounted on its shipping pallet about two feet in front of the cabinet. (If the pallet height does not place the WinterWarm slightly above the level of the elevated platform in the cabinet, the pallet itself must be raised.) Remove the load door, the front grate bars, the ash grate, the ashpan, and the ash door. Remove the two 5/16" lag bolts that secure the WinterWarm to the pallet. Slide the WinterWarm forward on the pallet until the front levelling screw holes are accessible; screw in the missing front levelling screw. All four levelling screws should be positioned so that they do not protrude below the plane of the shroud bottom. Push the WinterWarm back until the rear levelling screw holes are accessible; insert the missing levelling screw.

The WinterWarm firechamber is shipped with the reversible flue collar in the rearmost position. The flue collar **MUST** be in this position for use in the Fireplace System.

DO NOT REVERSE THE FLUE COLLAR ON THE FIRECHAMBER FOR USE IN THE WINTERWARM™ FIREPLACE SYSTEM.

OUTSIDE AIR

Install the Outside Air Kit in accordance with the instructions furnished with the kit. If you choose to install outside air, adhere to these guidelines:

- The air duct should be no longer than 20 feet (6 meters) with a maximum of three elbows, and should terminate at an outside air source.
- A butterfly valve should be positioned in the duct so that the incoming air can be shut off when not in use.
- Do not terminate the duct in a garage, attic, basement, or near another fuel-fed appliance.
- No portion of the duct may be higher than the primary air intake on the WinterWarm shroud.

CATALYTIC PROBE INSTALLATION

If you have purchased a catalytic probe (used to monitor temperatures in the secondary combustion chamber), install it at this time. Remove the twenty-two hex head self-tapping sheetmetal screws which secure the rear shroud panel. Remove the probe plug from the cast WinterWarm back. Select a drill bit corresponding to the size of the probe you have

purchased; spin the drill bit gently by hand through the exposed refractory material. Insert the probe carefully into the hole all the way to the probe's end. Route the probe lead right or left on top of the cast iron air guide, until the lead protrudes out the front. Replace and refasten the rear shroud panel.

OPTIONAL SURROUND

If using the optional surround panels, assemble them using the instructions packed with the panels, and lean the finished assembly against the chase front.

If you did not install the elevated base with the optional Fan Kit, install it at this time. Straighten the WinterWarm on the pallet and push the WinterWarm into the cabinet leaving about 2"-3" (50 mm. - 80 mm.) between the upper shroud flange and the front face of the cabinet. Remove the pallet.

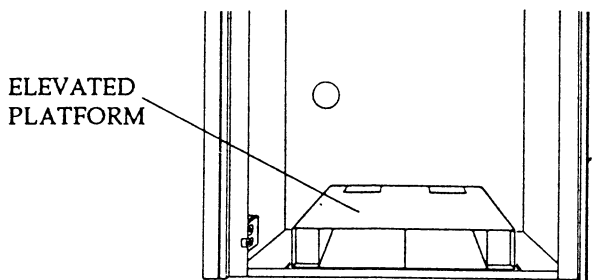

INSTALLING THE FRONT

Uncrate the front and remove the packing strap from the base of the two columns. Do not overlook the air dividers, which are packed against the side of the container. The WinterWarm is shipped with cover plates over the receptacles for both right and left junction boxes (located behind the right and left front columns). Remove the cover plate from the junction box on the LEFT column. **IMPORTANT: Never leave the right junction box receptacle exposed; make sure the cover plate is securely attached to the right junction box.**

The upper grill is shipped with its attaching cap screws loose. Leave these screws loose while installing the front, or it may be difficult to align.

With assistance, lift the front into position against the WinterWarm, starting with the left side. Move it behind the protruding load door hinge halves. Swing the right side into position.

Seat the front against the firechamber assembly, and attach with the six 1/4-20 x 3/4" hex head cap screws and washers provided, two for each side and two for the top. Make sure the front seats properly before tightening the cap screws — the edge of the front should be almost even with the side and top plates, protruding no more than 1/16" (2 mm.). Tighten left and right sides before tightening the top screws. Tighten the cap screws attaching the upper grill if necessary. Note: If the front has been installed too far forward, the door gasket may not make the required seal; the WinterWarm may be difficult to control in this situation.

Untape the rheostat linkage rod from the left side of the firechamber. Remove the nut from the threaded

end. Insert the rod end into the drilled hole in the rheostat lever located closest to the rheostat box shaft. (If your lever has only one hole, use that position.) The rheostat box is located on the inside of the left front column. Thread the rod nut back on and tighten.

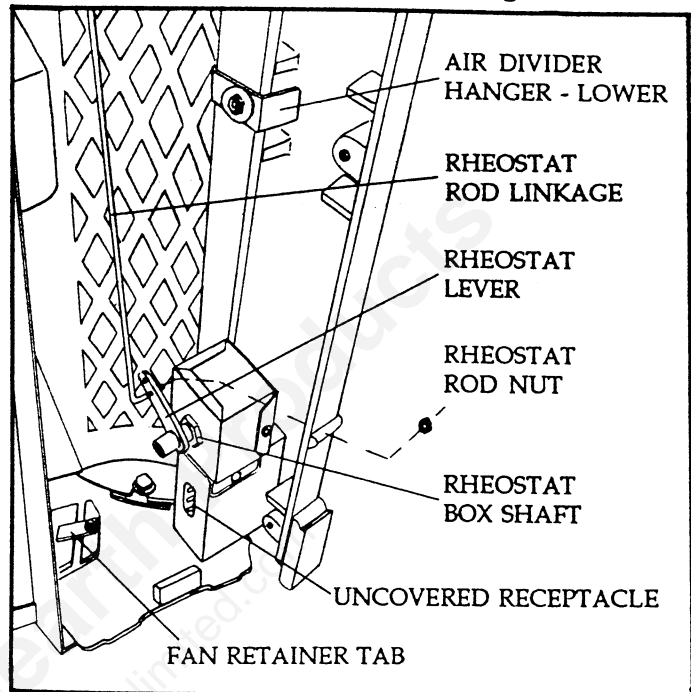

Remove the sheetmetal wire boxes which are attached to the the column bases. The right wire box is secured to the right column base with a 3/8" Phillips pan head machine screw and washer. The left wire box is secured to the column base with a 1-1/4" threaded spacer, a 1/2" Phillips pan head machine screw, and two flat washers. Remove the Phillips pan head machine screw and the nylon cord set clamp from the top of the spacer. Lay these parts aside as you will need them to complete your assembly.

INSTALL THE FANS

Both fans have their wire leads encased in protective sleeves. The left fan's leads terminate in a double socket connector. The right fan's leads terminate in two separate connectors, a single pin connector, and a single socket connector.

Loosen the cap screws that secure the fan retainer tabs. Install each fan with the wire mount facing the front. Lift up on the front edge of each horizontal sheetmetal air divider and maneuver the fan into position so that the wire mount falls under the retainer tab. When positioned correctly, the wire mount will lie in the groove cast into the column base; tighten the hex head cap screws to secure the fans with the retainer tabs.

CONNECT THE WIRING HARNESS

All the electrical connectors are of the pin and socket type, ranging in size from single to quadruple. The pin half fits into the socket half, and is properly connected when you "feel" a definite click. The double, triple, and quadruple connectors also have raised ribs on

one of their flat sides, which must line up before the connector halves will go together.

Connecting the left column wiring: There are three sleeves of wires protruding from the left of the WinterWarm; they terminate in one 4 socket connector, one 2 socket connector (from the fan), and one 2 pin connector. There are two sleeves of wires protruding from the base of the left junction box on the inside of the left column; these sleeves terminate at one 4 pin connector, one 2 pin connector, and one 2 socket connector. Connect the 4 socket connector to the 4 pin connector. Connect the 2 pin connector from the junction box to the 2 socket connector from the WinterWarm (fan). Connect the 2 socket connector from the junction box to the 2 pin connector from the WinterWarm.

Connecting the right column wiring: There are two sleeves of wires protruding from the right side of the WinterWarm. One sleeve terminates at one 3 socket connector and one single socket connector. The other (from the fan) terminates at one single socket connector and one single pin connector. Connect the single socket connector from the four wire sleeve to the single pin connector from the two wire (fan) sleeve. The one sleeve protruding from the bottom of the right junction box on the inside bottom of the right column terminates at one 3 pin connector and one single pin connector. Connect the 3 pin connector from the junction box to the 3 socket connector from the WinterWarm. Connect the single pin connector from the junction box to the single socket connector from the WinterWarm (fan).

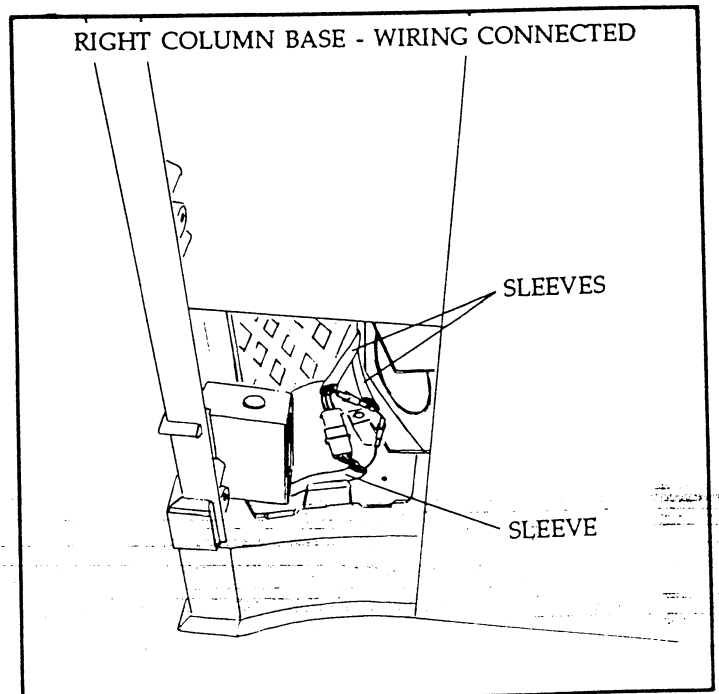
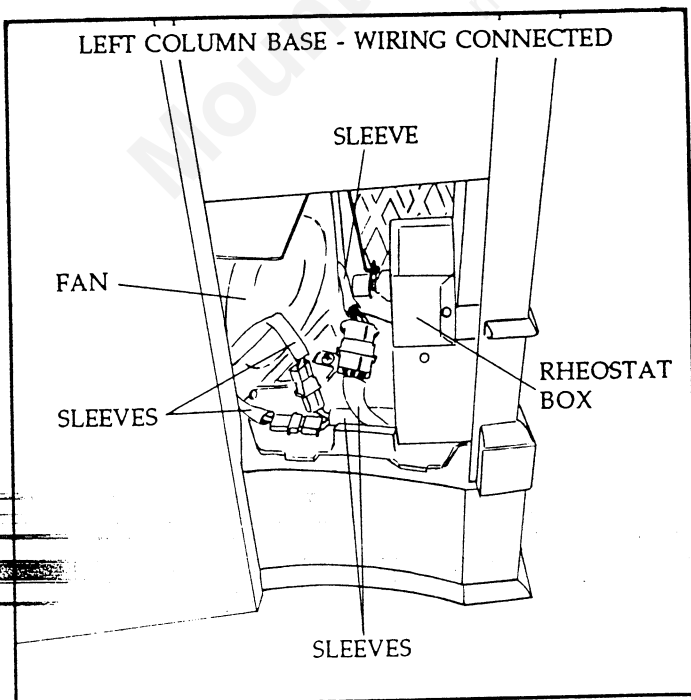
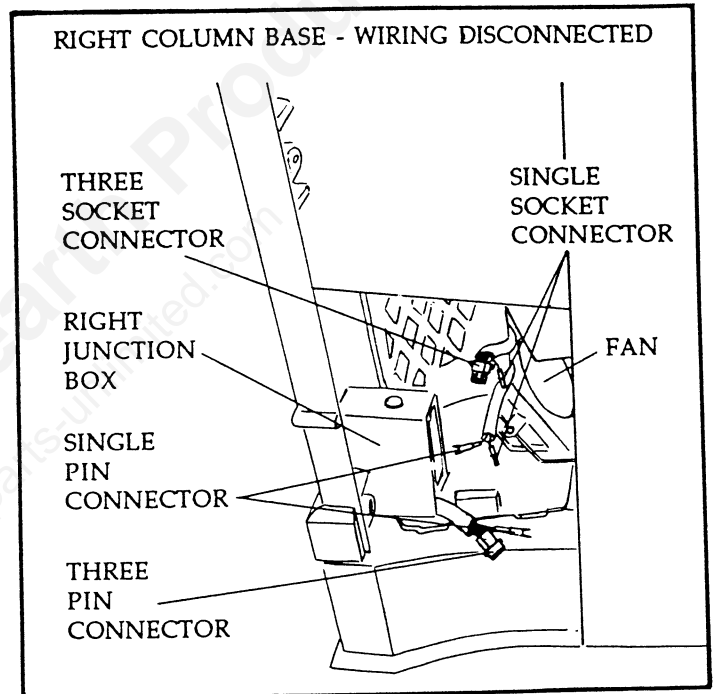
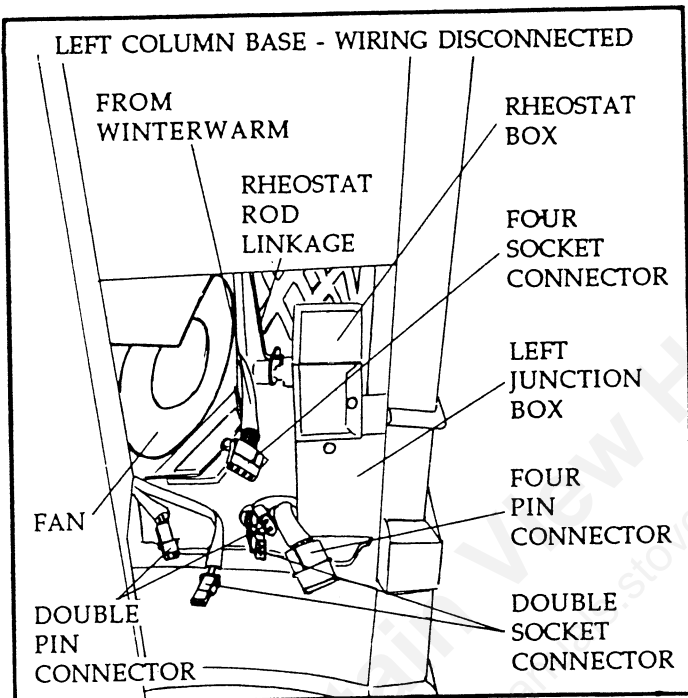

Installing the wire boxes: Gather the connectors neatly together and press them flat side down against the column bases. Place the right wire box over the connectors, making sure that the sharp edges of the box are not on top of any of the wire sleeves, and that the box does not protrude into the fan pathway. Secure the box to the column base with the 3/8" Phillips pan head machine screw and one washer. Place the left wire box similarly, and secure the box to the column base with the threaded spacer and two washers. Do not allow any portion of the wire box to protrude into the path of the fan blades. Slip the nylon cord set clamp over the cord set, plug the cord set into the junction box, and secure the clamp to the top of the spacer with the 1/2" Phillips

pan head machine screw.

Connect the power cord to the **UPPER** receptacle in the cabinet junction box. **NOTE:** If you are not using the optional Cabinet Fan, the lower receptacle in the cabinet junction box will not be live. If you plug the power cord for the WinterWarm into this receptacle, the column fans and their controlling switch will not work.

If you are unsure of how to make any of these connections contact your local Vermont Castings Authorized Dealer.

THE CONTROLS

The rods which operate the WinterWarm's primary air, fan, and damper should be installed before mounting the column capitals and mantel. The three rods and the accepting control levers are slightly different. Install the control rods by following this procedure:

- Thread the brass knob with the 3/8" tapped opening onto the short-threaded end of the 3/8" diameter rod; thread the remaining brass knobs onto the short-threaded ends of the 1/4" diameter rods.
- Thread the larger hex nut onto the longer threaded end of the 3/8" diameter rod all the way to the end of the thread. Thread the two smaller hex nuts onto the 1/4" rods. Thread one nut as far up the thread as possible; stop the second approximately 1/2" from the end.

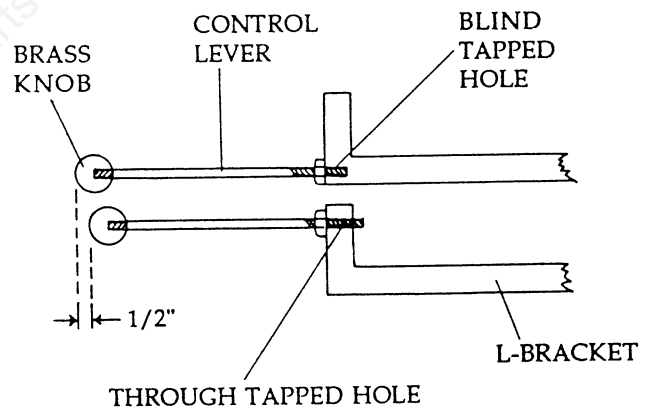

- Install the fan control rod by inserting the 1/4" diameter rod with the nut all the way at the end of the thread into the bottom control lever on the WinterWarm's left side. Install the rod all the way up to the nut.

- Tighten the hex nut against the lever.
- Thread the two remaining control rods into the remaining two control levers. The lever above the fan control accepts the remaining 1/4" rod; this is the primary air control. The lever on the right side of the WinterWarm accepts the 3/8" rod; this is the damper control.

- Thread each rod into the lever until it reaches the nut.
- Tighten the two hex nuts against the levers. The primary air and fan controls will be offset 1/2" to allow for smooth adjustment.

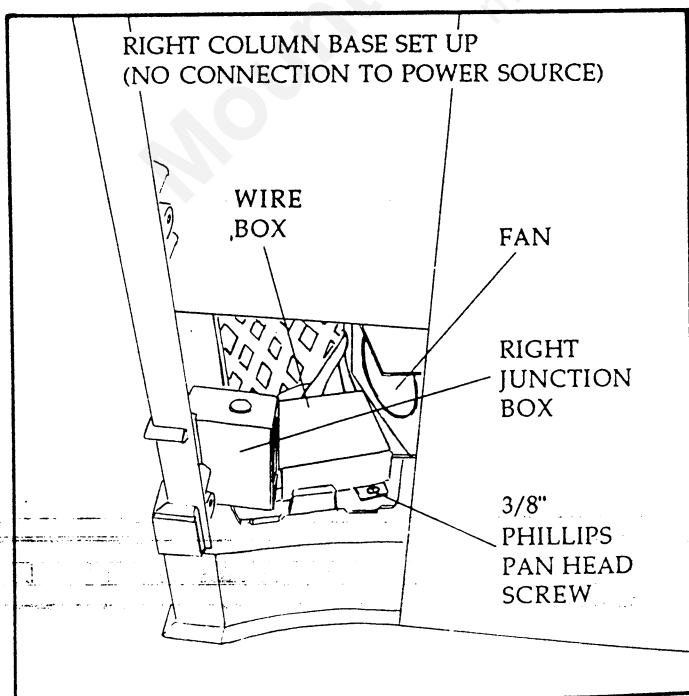
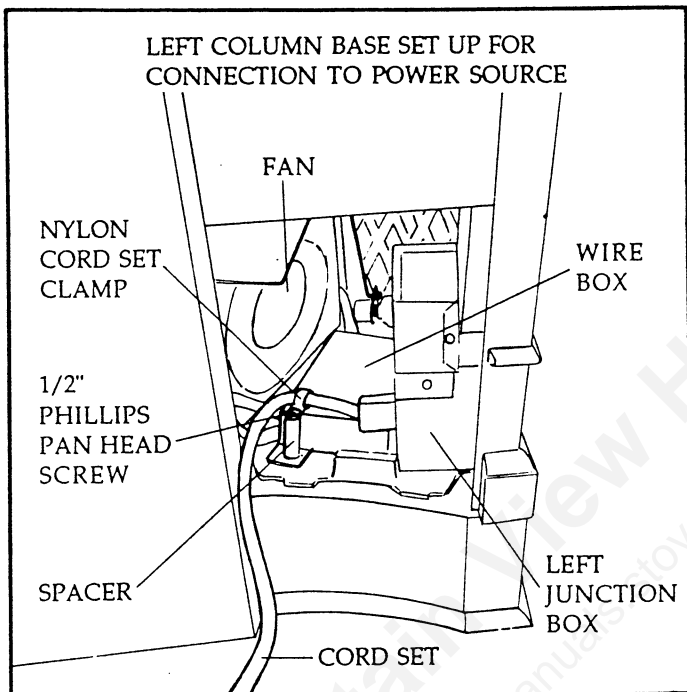

THE MANTEL AND AIR DIVIDERS

Install the two vertical sheetmetal air dividers which guide the incoming and outgoing convection air. The curved flange goes down and the two mounting tabs go toward the front. Angle the tabbed edge into position against the column first. Swing the rear edge parallel to the front edge, and engage the air divider's tabs onto the divider hangers attached to the right and left columns. Push down on the divider to secure it. In its final position, the air divider will be perpendicular to the column surface.

Place the mantel flat side down on the floor. Lift the mantel slightly and slip the drilled and tapped ends of the column capitals under each end of the mantel. Align the two tapped holes in each capital with the two holes in each end of the mantel, and thread in two 3/4" hex head cap screws and two washers. Do not tighten these cap screws with a wrench; leave them finger tight. Use care during this assembly process, especially with enamelled parts. Forcing the mantel or capitals into position may cause chipping or cracking.

Install the mantel and capital assembly by raising it into position and tilting it to the rear against the upper shroud flange. Push against the flange slightly before lowering the front edge of the assembly onto the upper trim piece.

Move the WinterWarm the final few inches into the cabinet, making sure the surround panels are properly aligned. If you are using the Vermont Castings Flex Connector System, reach up into the flue collar area to grasp the Starter Piece and pull it down into the flue collar. Bend the retaining tabs 90 degrees against the bottom of the flue collar.

The two curved side latticework panels are positioned with the corner cutouts on the back edge. The panels are interchangeable. However, the two metal plates which anchor the latticed panels to the WinterWarm front must be in different orientations

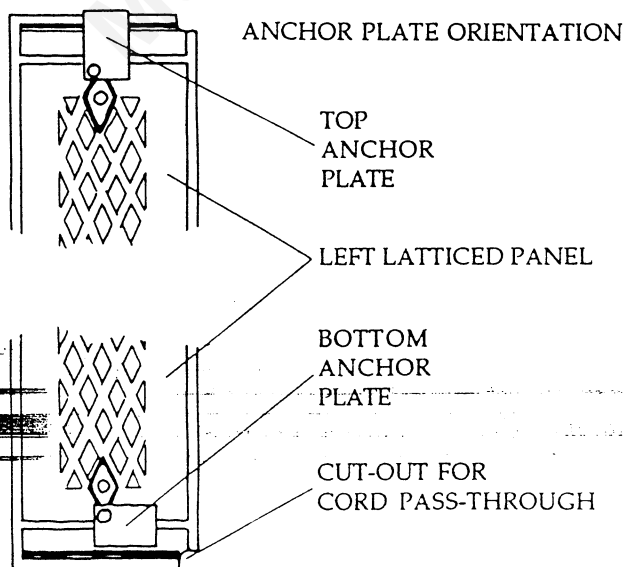

depending on whether they anchor the top or the bottom of the panel. Refer to the accompanying illustration. Notice that the top anchor plate must be rotated so that it protrudes as far as possible beyond the upper cast iron edge (the vertical position). The bottom anchor plate is rotated so that the long edge of the anchor plate is horizontal to the lower cast iron edge. To install the latticework panels, angle the top edge under the exposed overhang; the metal anchor plate will rest between the mantel edge and a stabilizing rib cast into the mantel's underside. Lift up slightly and bring the panel to vertical. Lower the panel and seat it firmly onto the base behind the molding; the bottom anchor plate will fit firmly behind the rib cast in the base plate. Make sure that the front flange of the WinterWarm shroud is behind the latticework panel.

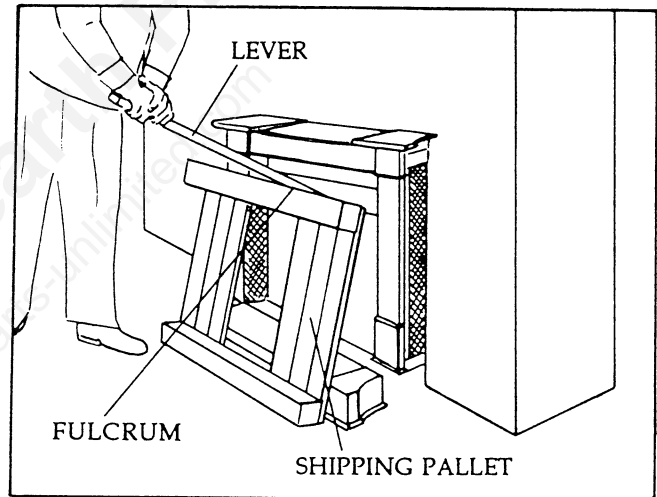

THE PLINTH

Remove the plinth center and invert it and the two end caps on a flat surface. Slide a flat washer on to each of the two hex head bolts which protrude from each plinth end. Next slip an L-bracket onto each bolt, with the oval slot parallel to the floor or work surface. Slide an additional washer onto the bolt, and secure the entire assembly with a hex nut. Repeat for the other end of the plinth. Measure the distance between the outer edges of the right and left front columns, and align the end caps and the plinth so that the distance between the outer front surfaces of the end caps equals the distance between the columns. Secure the four L-brackets to the end caps using one flat washer and a 1/4-20 x 3/8" Phillips round head machine screw installed through the oval slot in the bracket.

Set the assembled plinth in the upright position, in front of and centered on the WinterWarm. Place the WinterWarm shipping pallet on its side as shown in the accompanying illustration. Using the pallet as a fulcrum and a 30" length of 2" x 4" as a lever, insert the

end of the 2" x 4" into the load door opening until it passes a few inches under the front edge of the air manifold. Gently pry the front of the WinterWarm up as your assistant slides the plinth into position and centers it. Slowly lower the WinterWarm onto the plinth.

Replace the ashpan and ash door, front grate bars, bottom grate and load door.



Center the hearth extension in front of and abutting the front load door.

Glossary

FLUE: An opening which carries off smoke.

CHIMNEY: A masonry or prefabricated metal structure enclosing the flue.

CHIMNEY CONNECTOR: The sections of piping that connect an appliance to the flue of the chimney. Chimney connectors are used only in the house, never as chimneys.

CHIMNEY FLUE LINER: The metal, fire clay or other approved lining in a chimney that protects the chimney walls from the hot gases in the flue.

DAMPER: A valve controlling the flow of air or smoke into the chimney.

CLEARANCE: The minimum safe distance between the appliance (or chimney connector) and nearby combustible surfaces. The clearance distance must be empty space except for non-combustible heat shields, where allowed.

COMBUSTIBLE MATERIAL: Any material which will burn. A material is combustible if any part of it, either on the surface or in the interior, contains a combustible substance. Wood, wallpaper, paint, sheetrock, some veneer bricks, and plastic are all combustible materials.

NON-COMBUSTIBLE MATERIAL: Any material which will not burn when exposed to fire. Metal, brick, ceramic tile, concrete, stone, asbestos, and glass are all non-combustible. Floors, ceilings, and walls, including any unseen framework, must be constructed completely of such materials in order to be classified as non-combustible.

FLOOR PROTECTOR: A non-combustible pad placed in front of and to the sides of the WinterWarm, which protects the floor from sparks and falling embers.

HEARTH EXTENSION: A non-combustible pad placed in front of the WinterWarm load door which protects the floor from radiant heat emitted from the front of the fireplace.

FACTORY-BUILT FIREPLACE: A fireplace designed to be installed with a prefabricated, factory-built chimney. **NOTE: NOT SUITABLE FOR USE WITH THE WINTERWARM™.**

MASONRY HEAT FORM: A factory-built metal form around which a code-approved masonry fireplace and a code-approved masonry chimney can be built. **NOTE: SUITABLE FOR USE WITH THE WINTERWARM™ IF INSTALLED ACCORDING TO DIRECTIONS IN THIS MANUAL.**

ZERO-CLEARANCE FIREPLACE: A term used to describe a type of factory-built fireplace and chimney, with enough insulation and/or air space to allow installation directly next to combustible materials. A more accurate term is "reduced-clearance fireplace".

NOTE: THE WINTERWARM™ IS A LISTED FIREPLACE PART FOR USE WITH THE VERMONT CASTINGS FIREPLACE CABINET, MODEL #1283. IN THIS APPROVED INSTALLATION, AND IN THIS INSTALLATION ONLY, THE WINTERWARM™ MAY BE USED IN A REDUCED-CLEARANCE SITUATION.

REDUCED-CLEARANCE CABINET (ALSO CALLED "ENCLOSURE"): The tested and listed component into which a tested and listed firechamber is inserted. The completed assembly is considered a reduced-clearance fireplace.

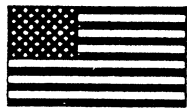

APPENDIX - APPROVED CHIMNEY COMPONENTS*

Component	Security ASHT	Selkirk Metal-bestos SSII	GSW (Jacks-Evans SC)	Metal-Fab Model TG	Vitroliner HS Type HT
Anchor Plate	8 JP	8T-AP	JSC 8 AP	8TG AP	8H-SP
Chimney Sections	8 L3 8 L2 8 L18 8 L1 8 L8	8T-36 8T-18 8T-9 8T-6 8T-3	JSC 8 SA3 JSC 8 SA2 JSC 8 SA1	8TG 36 8TG 24 8TG 18 8TG 12 8TG 6	8H-SCS36 8H-SCS24 8H-SCS18 8H-SCS12 8H-SCS6
Elbows	8 E15 8 E30	8T-EL15 8T-EL30	JSC 8 SE	8TG A15 8TG A30	8H-SEI15 8H-SEI30
Firestops/ Shields	8 RSA	8T-AIS 8T-JS 8T-WS 8T-TCS	JSC 8 AIS JSC 8 FRS JSC 8 FAIS	8TG IS 8TG RSH 8TG FSA	8H-AJS 8H-RJS 8H-FJS 8H-WS
Storm Collar		8T-SC	JSC 8 ASC	8TG SC	8H-CSC
Caps	8 CPR 8 CC, 8 CPE	8T-CT	JSC 8 DRC JSC 8 RC	8TG C 8TG RC	8H-CRCA
Wall Band	8 BM	8T-WB	JSC 8 WB	8TG WB	8H-CGR
Flashings	8 F 8 FPA 8 FPB 8 FA 8 FB 8 FBB	8T-TF 8T-AF6 8T-AF12 8T-AF24 8T-AF36	JSC 8 ATC JSC 8 AAF JSC 8 AF2 JSC 8 AF3	8TG F 8TG 15 8TG F24 8TG FT	8H-CFF 8H-CPL 8H-CFM 8H-CFH 8H-CFS
Supports	8 SM 8 ST 8 S 8 SC	8T-WSK 8T-RSP 8T FSP	JSC 8 WS JSC 8 WSK JSC 8 DCS JSC 8 DCSK JSC 8 CCS JSC 8 CCSK	8TG WS 8TG RS 8TG SB	8H-SSL4 8H-SSL9 8H-SSL18 8H-SSL24 8H-SSL36 8H-SRL4 8H-SRL9 8H-SRL18 8H-SRL24 8H-SRL36

* Check with chimney manufacturer for additions and deletions to this list.



Vermont Castings, Inc.
Prince Street
Randolph, Vermont
U.S.A.

Vermont Castings, Inc.
44 Friargate
Derby
Derbyshire DE1 1DA
England

November©1988 Vermont Castings, Inc. All rights reserved. Parts and specifications subject to change without notice.

Printed in the U.S.A.

#200-0932